

ULTRAPAN[®]

Installation & Operator's Manual

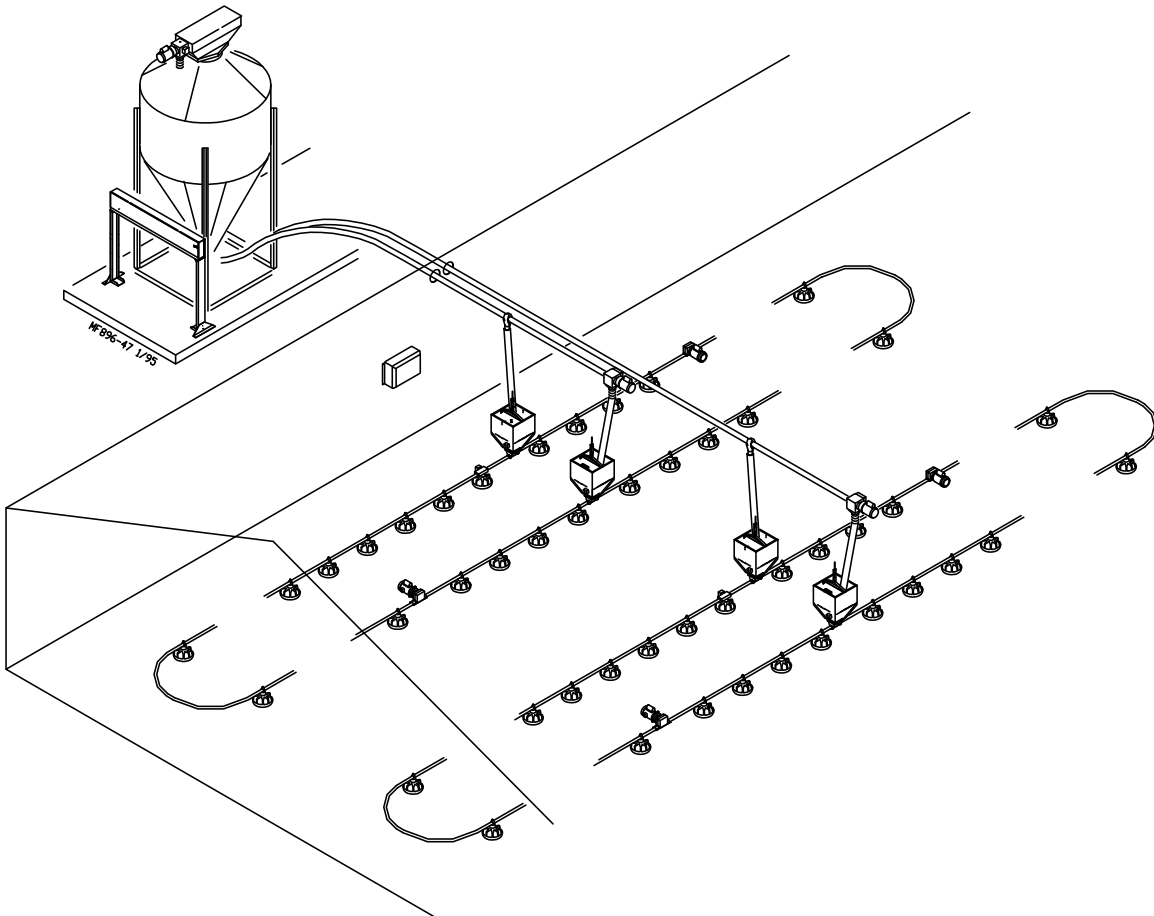

The Chore-Time Warranty

LIMITED WARRANTY

CTB, Inc. (“Chore-Time”) warrants each new CHORE-TIME Product manufactured by Chore-Time to be free from defects in material or workmanship under normal usage and conditions, for One (1) year from the date of installation by the original purchaser (“Warranty”). Chore-Time provides for an extension of the aforementioned Warranty period (“Extended Warranty Period”) with respect to certain Product parts. If such a defect is determined by Chore-Time to exist within the applicable period, Chore-Time will, at its option, (a) repair the Product or Component Part free of charge, F.O.B. the factory of manufacture or (b) replace the Product or Component Part free of charge, F.O.B. the factory of manufacture. This Warranty is not transferable, and applies only to the original purchaser of the Product.

CONDITIONS AND LIMITATIONS

THIS WARRANTY CONSTITUTES CHORE-TIME’S ENTIRE AND SOLE WARRANTY AND CHORE-TIME EXPRESSLY DISCLAIMS ANY AND ALL OTHER WARRANTIES, INCLUDING, BUT NOT LIMITED TO, EXPRESS AND IMPLIED WARRANTIES, INCLUDING, WITHOUT LIMITATION, WARRANTIES AS TO MERCHANTABILITY OR FITNESS FOR PARTICULAR PURPOSES. CHORE-TIME shall not be liable for any direct, indirect, incidental, consequential or special damages which any purchaser may suffer or claim to suffer as a result of any defect in the Product. Consequential or Special Damages as used herein include, but are not limited to, lost or damaged products or goods, costs of transportation, lost sales, lost orders, lost income, increased overhead, labor and incidental costs, and operational inefficiencies. *Some jurisdictions prohibit limitations on implied warranties and/or the exclusion or limitation of such damages, so these limitations and exclusions may not apply to you. This warranty gives the original purchaser specific legal rights. You may also have other rights based upon your specific jurisdiction.*

Compliance with federal, state and local rules which apply to the location, installation and use of the Product are the responsibility of the original purchaser, and CHORE-TIME shall not be liable for any damages which may result from non-compliance with such rules.

The following circumstances shall render this Warranty void:

- Modifications made to the Product not specifically delineated in the Product manual.
- Product not installed and/or operated in accordance with the instructions published by the CHORE-TIME.
- All components of the Product are not original equipment supplied by CHORE-TIME.
- Product was not purchased from and/or installed by a CHORE-TIME authorized distributor or certified representative.
- Product experienced malfunction or failure resulting from misuse, abuse, mismanagement, negligence, alteration, accident, or lack of proper maintenance, or from lightning strikes, electrical power surges or interruption of electricity.
- Product experienced corrosion, material deterioration and/or equipment malfunction caused by or consistent with the application of chemicals, minerals, sediments or other foreign elements.
- Product was used for any purpose other than for the care of poultry and livestock.
-

The Warranty and Extended Warranty may only be modified in writing by an officer of CHORE-TIME. CHORE-TIME shall have no obligation or responsibility for any representations or warranties made by or on behalf of any distributor, dealer, agent or certified representative.

Effective: June 2001

Thank You

The employees of Chore-Time Equipment would like to thank your for your recent Chore-Time purchase. If a problem should arise, your Chore-Time distributor can supply the necessary information to help you.

Table of Contents

<u>Topic</u>	<u>Page</u>
Warranty Information	2
Support Information	4
Safety Information	5
Component Identification	6
Introduction, Specifications Floor Feeding System Weight Chart .	7
Planning The System	8 - 9
Installing the ULTRAPAN Feeder	10 - 34
Suspending the Feeder Line, Suspension System.....	10 - 11
Screw Hook Installation, Ceiling Hook Installation	12 - 13
Power Winch Installation	14
Drop Installation.....	15
Pan Assembly, Feeder Assembly Procedure.....	16 - 17
Feeder Line Assembly	17 - 20
ULTRAPAN® Control	20 - 21
Adjustable Hanger Installation.....	22
Indexing the Tubes	23
Auger Installation.....	24 - 25
Auger Connector Installation	25 - 26
Auger Brazing.....	26
Suspending The Feeder.....	27 - 31
Anti-Roost Installation.....	32 - 34
Proximity Intermediate Control	35 - 37
Operation, Setting the Delay, Adjusting The Sensitivity	36
Wiring, Schematic.....	37
System Wiring Diagrams & Operational Information	38 - 48
System Overview for use with Wiring Diagrams.....	38
ULTRAPAN Feeding System Wiring Diagram, Mechanical Weigh-Matic Scales (single phase)	39
ULTRAPAN Feeder System Wiring Diagram, Mechanical Weigh-Matic Scales (3 phase).....	40 - 42
ULTRAPAN Feeder System Wiring Diagram, Other Brand Scales (3 phase)	43
Digital Weigh-Matic / ULTRAPAN Feeder Control Wiring Diagram.....	44
Operation of the Feeder, 34380 Breeder Control, Balancing the Mechanical Scale	45 - 46
Operation of the Scale, Start-Up Procedure.....	46
ULTRAPAN Management Guidelines	47 - 48
Parts List	49 - 58
Hopper Components	49
8789 Lower Hopper Switch Assembly, 34824 Boot Assembly	50
Miscellaneous Components	51
ULTRAPAN Feeders Pans (Standard & Shallow).....	51 - 55
Model C2 PLUS® Intermediate Control (Standard & Shallow), 14251 Indexing Gauge	56
Power Unit and Driver Assembly.....	57
47687 Winch, Miscellaneous Suspension Components.....	58
Maintaining the ULTRAPAN Feeder	59 - 60

Support Information

The Chore-Time ULTRAPAN® Feeding System is designed to feed poultry. Using this equipment for any other purpose or in a way not within the operating recommendations specified in this manual will void the warranty and may cause personal injury and/or death.

This manual is designed to provide comprehensive planning, installation, wiring, operation, and parts listing information. The Table of Contents on page 3 provides a convenient overview of the information in this manual. The Table of Contents also specifies which pages contain information for the distributor, installer, and customer (end user).

Chore-Time Equipment recognizes CE Mark and pursues compliance in all applicable products. Fill in the CE-Mark serial number in the blank space provided for future reference.

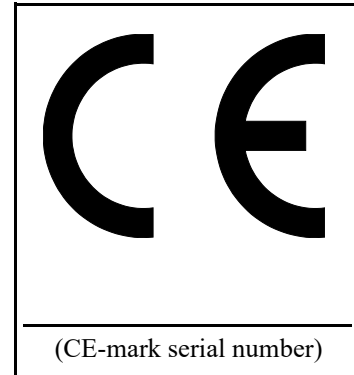

Please fill in the following information about your ULTRAPAN® Feeding System. Keep this manual in a clean, dry place for future reference.

Distributor's Name _____

Distributor's Address _____

Distributor's Phone _____ **Date of Purchase** _____

Installer's Name _____

Installer's Address _____

Installer's Phone _____ **Date of Installation** _____

System Specifications _____

Feed Delivery System _____

The following tools are required to install Chore-Time equipment. These tools are not supplied with the equipment and must be supplied locally.

- | | |
|--|-----------------------------------|
| 1. Open end wrenches (standard) | 7. Bolt cutters |
| 2. Ratchet wrench and sockets (standard) | 8. Hacksaw |
| 3. Screwdrivers (standard and phillips) | 9. Hole-Saw (various sizes) |
| 4. Side cutters | 10. Locking pliers |
| 5. Wire strippers | 11. Electric drill and drill bits |
| 6. Hammer | 12. Acetylene Welder |

SAFETY INFORMATION

Caution, Warning and Danger Decals have been placed on the equipment to warn of potentially dangerous situations. Care should be taken to keep this information intact and easy to read at all times. Replace missing or damaged safety signs.

Using the equipment for purposes other than specified in this manual may cause personal injury or damage to the equipment.

Safety–Alert Symbol

This is a safety–alert symbol. When you see this symbol on your equipment, be alert to the potential for personal injury. Chore–Time equipment is designed to be installed and operated as safely as possible...however, hazards do exist.



Signal Words

Signal words are used in conjunction with the safety–alert symbol to identify the severity of the warning.

DANGERidentifies immediate hazards which WILL result in severe personal injury or death.

WARNING.....identifies hazards or unsafe practices which COULD result in severe personal injury or death.

CAUTIONidentifies hazards or unsafe practices which COULD result in minor personal injury or product or property damage.



DANGER



WARNING



CAUTION

DANGER—MOVING AUGER

This decal is placed on the Clean-Out Cover of the FLEX-AUGER Control Unit.

Severe personal injury will result, if the electrical power is not disconnected, prior to servicing the equipment.

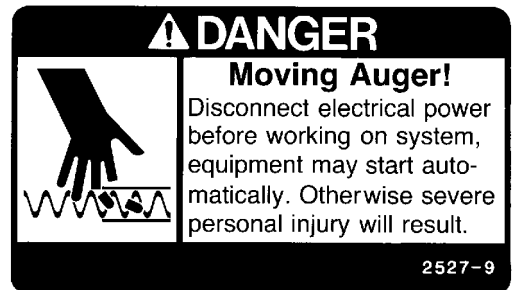

DANGER—ELECTRICAL HAZARD

Disconnect electrical power before inspecting or servicing equipment unless maintenance instructions specifically state otherwise.

Ground all electrical equipment for safety.

All electrical wiring must be done by a qualified electrician in accordance with local and national electric codes.

Ground all non-current carrying metal parts to guard against electrical shock.

With the exception of motor overload protection, electrical disconnects and over current protection are not supplied with the equipment.

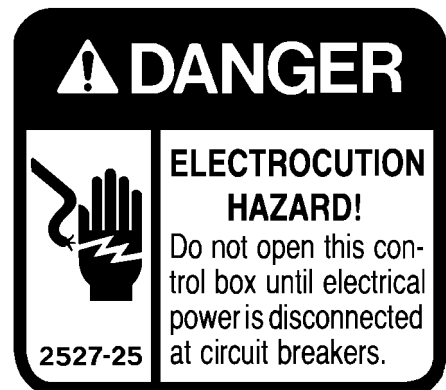

CAUTION

*Use caution when working with the Auger.
Springing auger may cause personal injury.*

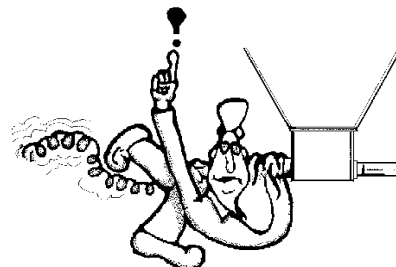

Component Identification

Model C2 Plus Breeder Feeder Pan

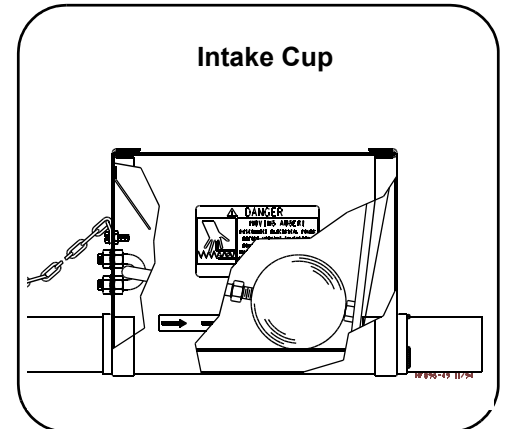
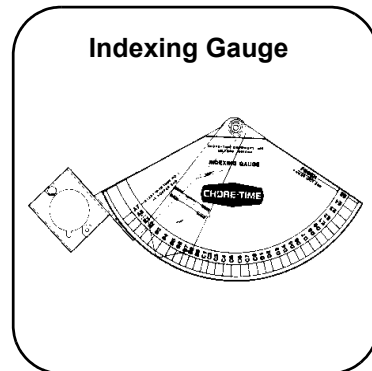
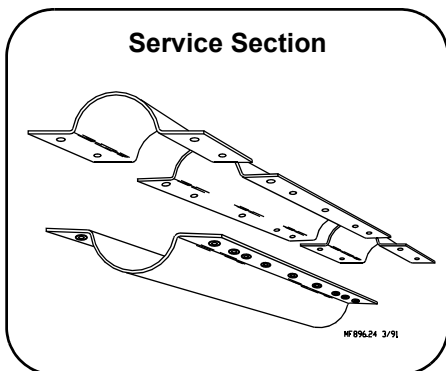
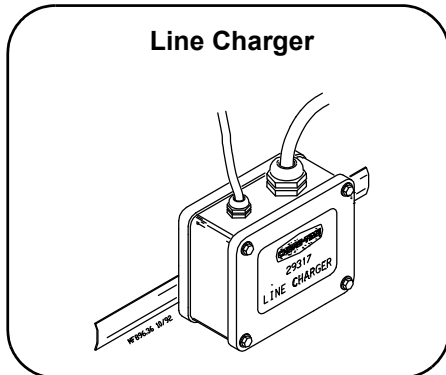
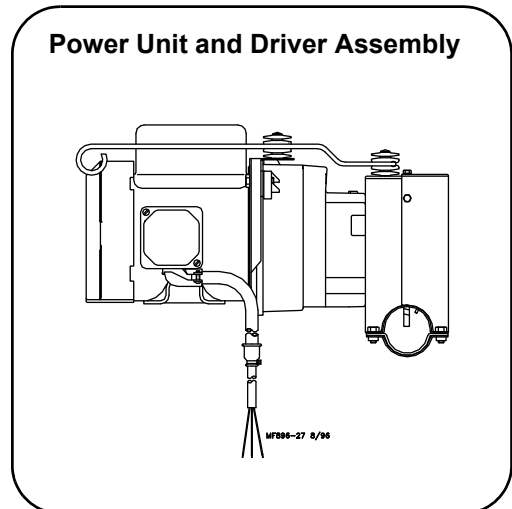
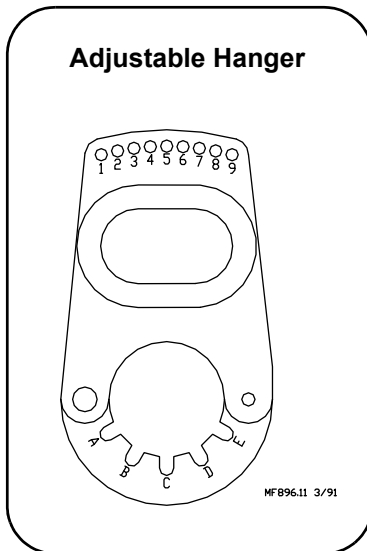
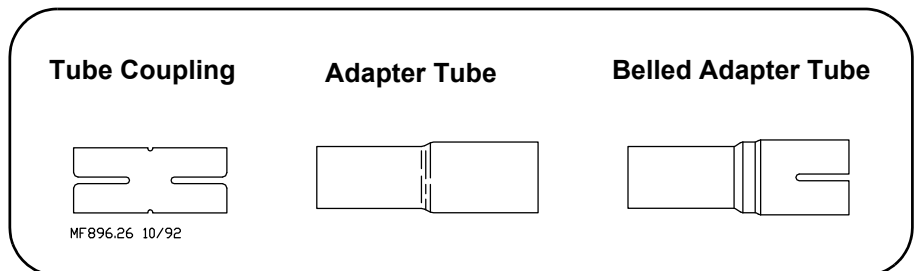
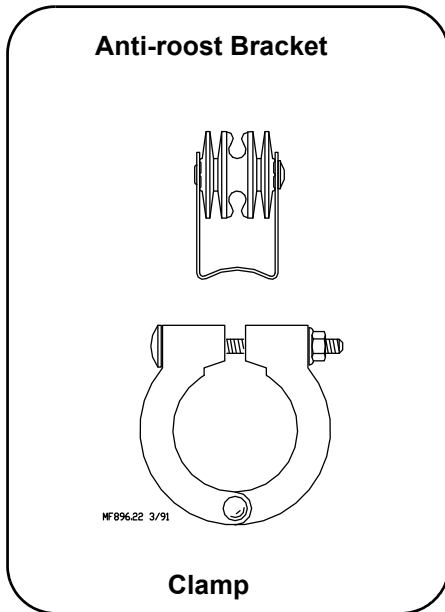
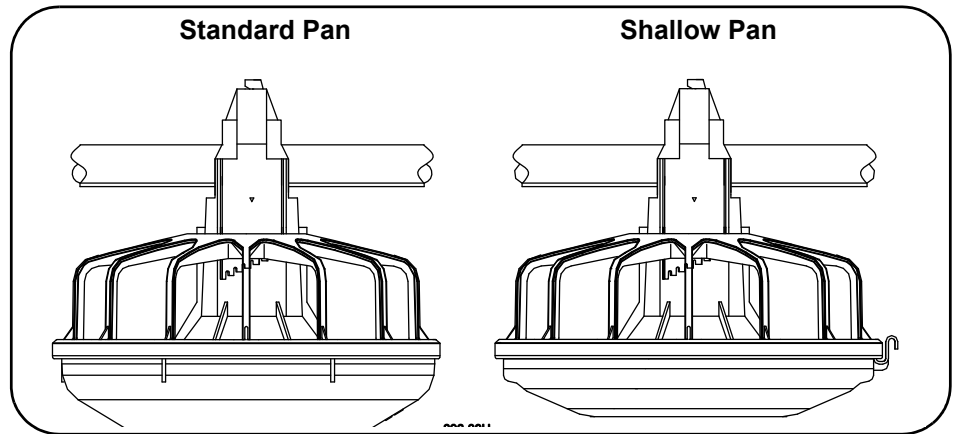
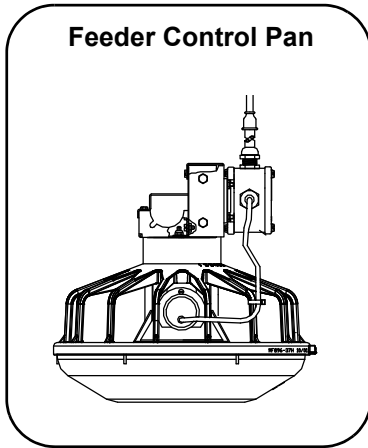

Introduction

Chore-Time® has designed the ULTRAPAN® Feeder System to dispense feed immediately and uniformly at a fast rate to broiler breeder pullets and hens.

Feed is delivered to the ULTRAPAN® hoppers by a high speed CHORE-TIME® FLEX-AUGER® Feed Delivery System. The feeder auger pulls the feed from the hoppers to be discharged into the MODEL C2®PLUS *Breeder Series* feeder pans. The MODEL C2®PLUS *Breeder Series* Feeder Pan Assembly includes an internal feed reduction tube that reduces the amount of feed stored in the feed cone.

The ULTRAPAN® Feeding System is controlled by:

1. CHORE-TIME® AGRI-TIME® Breeder Control part number 34380 for Mechanical WEIGH-MATIC® Scale Systems, Mechanical WEIGH-MATIC® Scales are available in two capacities: 5,000lb.[2,268kg] and 8,000lb.[3,628kg].

Refer to instruction manual MF1061 for installation and operation procedure for the 34380 Breeder Control Panel. Refer to instruction manual MF1291 for the Mechanical WEIGH-MATIC® Scales.

2. CHORE-TRONICS® Feeder Control 40722 is used with the Digital WEIGH-MATIC® Scale System. The Digital WEIGH-MATIC® Scale Systems are available in capacities from 5,000lb.[2,268kg] to 110,000lb.[49,896kg].

Refer to instruction manual MT1559 for installation and operation procedure for 40722 Feeder Control Panel. Refer to instruction manual MF975 for the Digital WEIGH-MATIC® Scales.

Capacities and Specifications

The ULTRAPAN® Feeder System utilizes 95 RPM power unit providing a delivery capacity of approximately 55 pounds [25kg] per minute per hopper. The feed is delivered through the indexed tubes at a rate of approximately 130ft.[40m] per minute. A typical ULTRAPAN® Feeder with 2 hoppers has a capacity of approximately 110lb.[50kg] per minute, which requires a high speed 580rpm, MODEL 90 FLEX-AUGER® for feed supply.

The ULTRAPAN® has available models with feeder tubes for nine(9) foot/four(4) pan, ten(10)/four(4) pan, and twelve(12)/four(4) pans, for versatility of various building size, bird types, and bird densities. Maximum straight tube line length is 504ft.[152m].

Standard feeder circuit width is 9ft.[2.7m]: minimum width is 5ft.[1.5m].

Floor Feeding Systems Weight Chart for determining support requirements

Use the chart below as a reference guide for determining support load requirements for your system.

ULTRAPAN COMPONENTS

Tube, Auger, Feed, & Pan	5.0 lb./ft. 7.5 kg./m
Power Units	35 lbs. (15.88 kg)
100# Hoppers	140 lbs. (63.50 kg.)

Planning the System

Carefully planning the system prior to beginning the installation will save time and effort. Refer to the FLEX-AUGER Fill System Manual for fill system installation information and specifications.

The diagram on page 8, shows a house with two ULTRAPAN Feeder loops. The line lengths specified for determining power unit placement refer to the distance between the elbows. However, the total system length = line length X 2, plus the elbows (including the tube between the elbows).

The *first loop* shows the recommended placement of the Power Units, Hoppers, Control Unit, and Weigh Bin.

For line lengths up to 288' (87.7 m), two (2) power units are recommended. The power units should be evenly spaced opposite each other. For line lengths to 288' (87.7 m), the power units should be placed in positions "A" and "C" below.

For line lengths from 288' to 387' (87.7 to 118 m), three (3) power units are recommended. To determine the proper placement of the power units, add the total length of the system, including 3'[1m] for each 90 degree end section, and divide by 3. This will give an approximate distance between power units, round up or down to the nearest suspension drop line. These power units should be staggered (two on one side, one on the other side). The power units should be placed in positions "A", "B", and "D" below.

For line lengths from 387' to 500' (118 to 152m), four (4) power units are recommended. To determine the proper placement of the power units, add the total length of the system, including 1'[3m] for each 90 degree end section, and divide by 4. This will give an approximate distance between power units, round up or down to the nearest suspension drop line. The power units should be placed in positions "B", "E", "D", and "F" below.

The Control Unit should be located on the side of the feeder loop to be used for partial

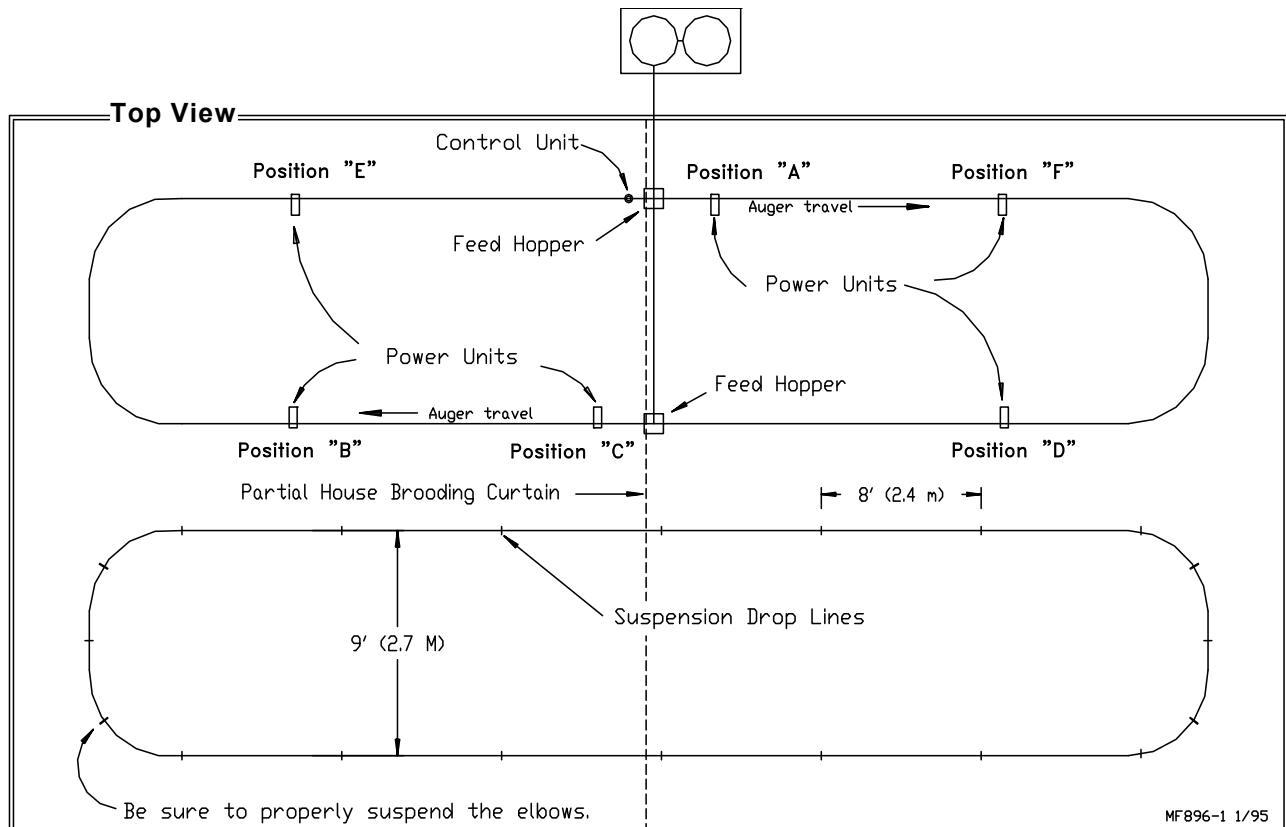

house brooding. The Control will be installed next to the hopper on the return side of the feeder. The two holes prior to the control must be enlarged.

The *second loop* gives some dimensional specifications.

NOTE: the suspension drop lines are spaced 8' (2.4 m) apart all through the system. Systems using 10' (3 m) or 12' (3.6 m) tubes may be suspended on 10' (3 m) centers. Be sure to support the elbows as shown in this manual.

The ULTRAPAN Feeder loop is 9' (2.7 m) wide and can be reduced to 5'[1.5m] if needed.

NOTES

Installation of the ULTRAPAN Feeder

Suspending the Feeder Line

The ULTRAPAN Feeder uses the 7604 Adjustable Hanger to index the feeder tubes for uniform feed distribution. The 7604 Adjustable Hanger must be installed in the correct position to index the ULTRAPAN Feeder as it is suspended.

Refer to page 22 for additional 7604 Adjustable Hanger installation instructions.

Suspension System

1. The feeder line suspension system is a vital part of the feeding system. Proper planning and installation is necessary to insure proper operation of the system. A system weight chart is provided on page 7 that may be used to determine load requirements.
2. **Figure 1**, on **page 10**, shows the correct suspension system for all feeder line lengths. Notice additional support must be provided at each Hopper, Power Unit, and elbow location.

IMPORTANT: Notice that the feeder line **MUST BE SUPPORTED WITHIN 1 FOOT (300 MM) OF THE HOPPER AND DIRECTLY ABOVE THE MOTOR ON THE CONTROL UNIT.** If a Control Unit or Hopper does not come out directly under a truss, fasten a pulley to a 2x8 (50x200 mm) board or other type of support that will span (2) truss.

3. Determine where the feeder line is to be installed. Mark a straight line on the ceiling or rafters the full length of the feeder line. Use a string, chalk line, or the winch cable, temporarily attached with staples, to mark the line. Center the line directly over where the feeder is to be installed. For feeder lines over 350' [107m], a block & tackle is required on the main cable line. See **figure 1 Detail "A"** on following page.
4. The recommended distance between the drops is 8' (2.4 m) on center. Do not exceed 10' (3 m) spacing on drop lines.
5. If the distance raised is greater than the distance between the drop spacings, offset the hooks 3" (75 mm) to each side of the line to prevent the cable clamps from catching the pulleys. See **Figure 2**.

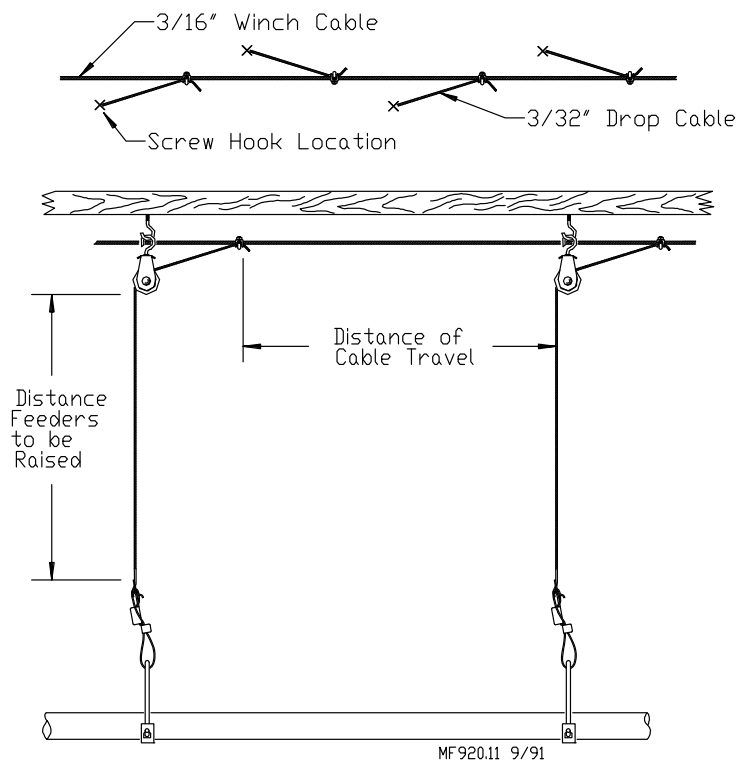

Figure 2. (Side View)

MF920.11 9/91

Suspension Layout Graphic

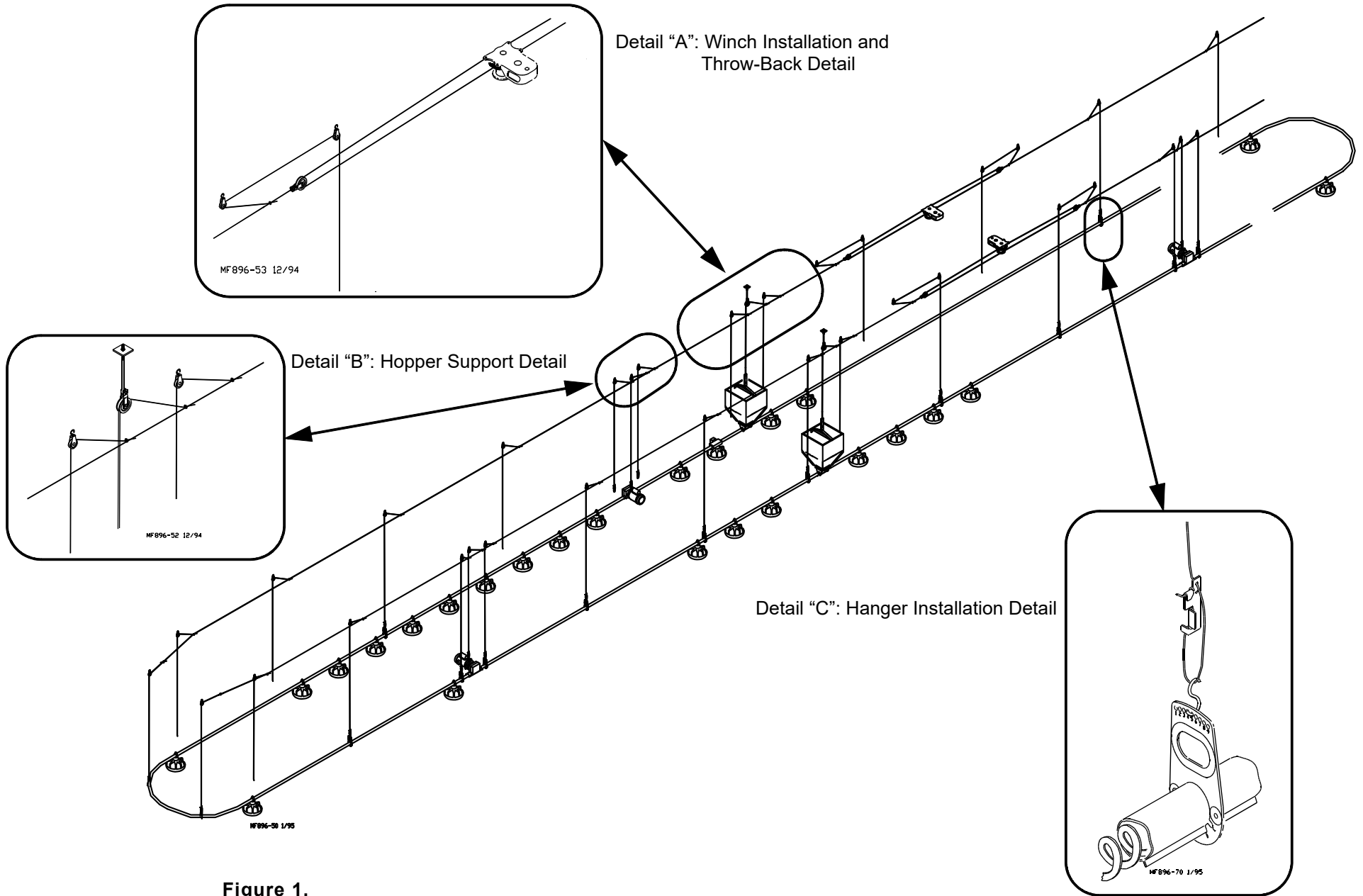

Figure 1.

6. Refer to **Figures 3 or 4 through 7** for specific installation instructions for the screw hooks and ceiling hooks.
7. For installations using wood trusses, standard screw hook or the optional Ceiling Hook may be used to hold the pulley assemblies.
8. For installations using steel trusses, the Ceiling Hooks are available to hold the pulley assemblies.

Screw Hook Installation

1. Screw the hook into the truss the full length of the threads to prevent bending.
2. The openings of the screw hooks must be pointed away from the direction of travel when the Power Winch raises the feeder line. See **Figure 3**.

Ceiling Hook Installation

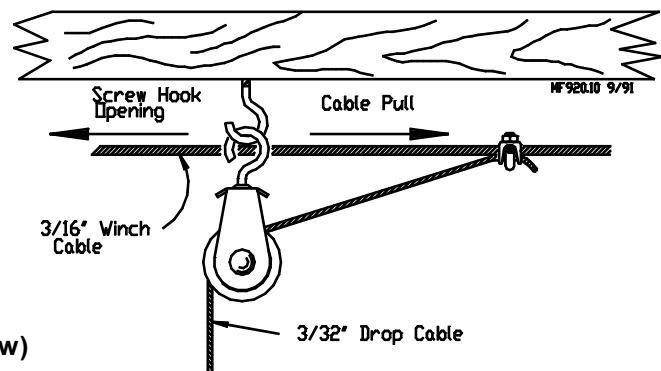

Figure 3. (Side View)

1. The ceiling hook may be used in a variety of installations. Depending on your ceiling or rafter type, install the Ceiling Hooks as shown in **Figures 4 - 7**.
2. After securing the Ceiling Hook to the truss, slide the hook of a Swivel Pulley into the slot, as shown in **Figure 8**.

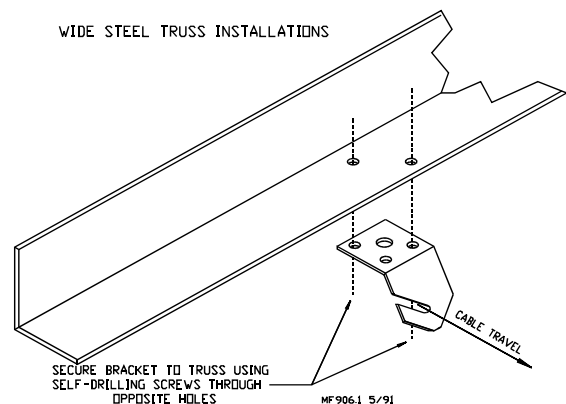

Figure 4.

NARROW STEEL TRUSS INSTALLATIONS

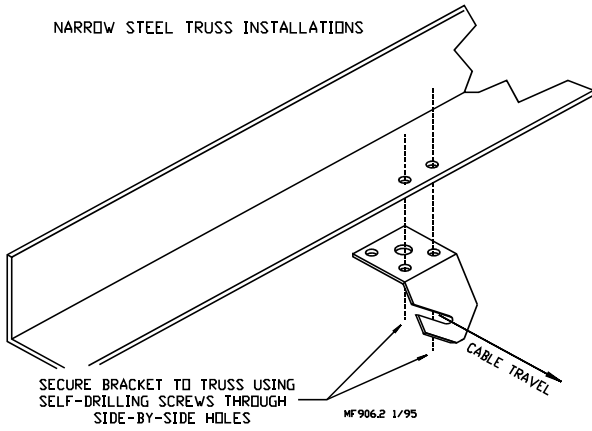

Figure 5.

STEEL TRUSS WELDED INSTALLATIONS

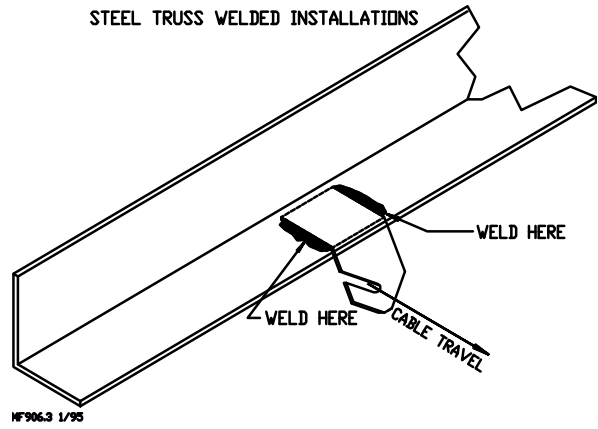

Figure 6.

WOOD TRUSS INSTALLATIONS

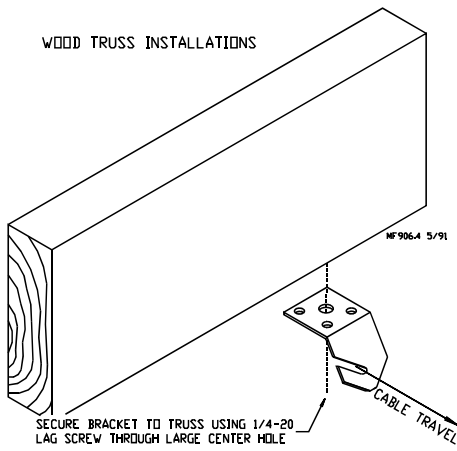

Figure 7.

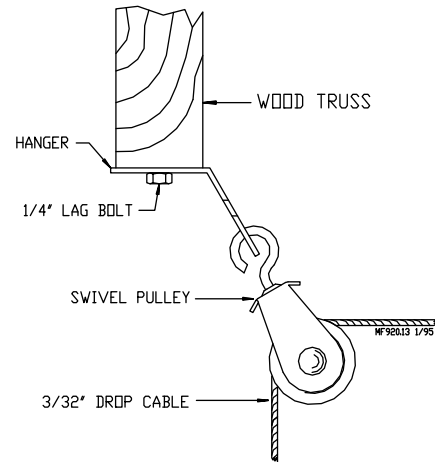

Figure 8. (End View)

Power Winch Installation

1. Attach the 2" x 8" [50 x 200mm] board, or angle iron fixture, to the ceiling at the center of the feeder line. The 2" x 8" [50 x 200 mm] must be parallel to the line and must span at least 3 rafters.

If the hopper is located at the center of the feeder line, locate the winch support a few feet offset from the center of the feeder line. However, the Winch Drum must be directly in line with where the main cable is to be installed.

2. Attach the Power Winch to the winch support 2"x8"[50 x 200mm] board or angle iron fixture. Install a Cable Hook (#2985) between the mounting bolt and Power Winch frame, as shown in **Figure 9**.
3. Extend the 3/16" (5 mm) cable the full length of the feeder line. Attach the cable temporarily to the ceiling with nails, staples, or some type of fasteners.
4. Wrap the cable through the winch drum relief located near the bottom of the drum. Tighten the set screw to anchor the cable to the drum. See **Figure 10**.

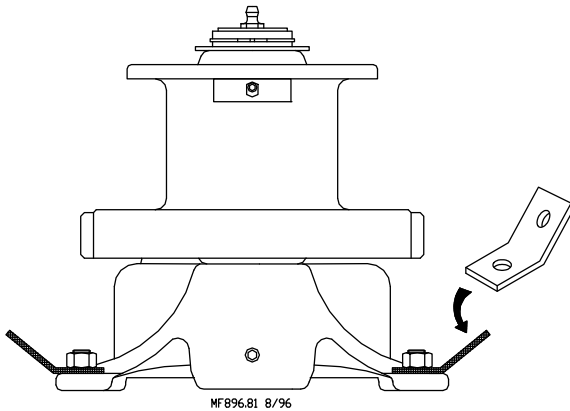

Figure 9. (End View)

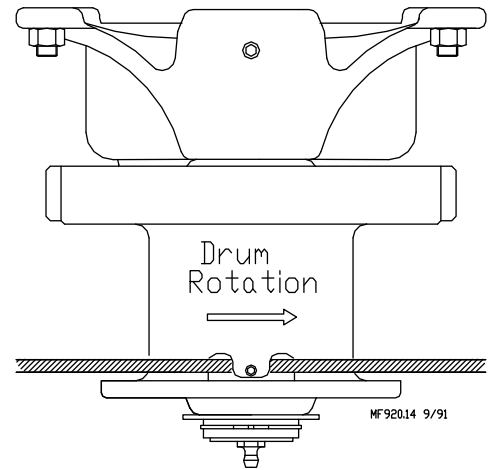

Figure 10. (End View)

5. Turn the winch drum two full revolution. Guide the cable against the flange at the bottom of the winch drum. The cable must not wrap over itself on the drum, but should be wrapped as close as possible to each previous wrap. See **Figure 11**.

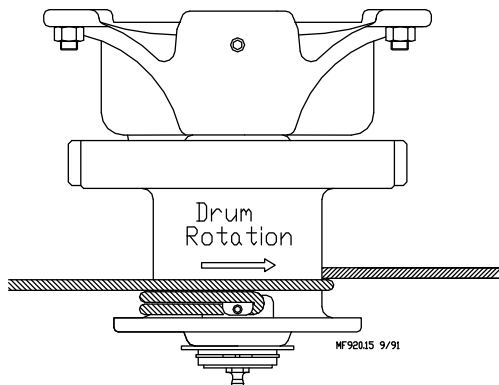
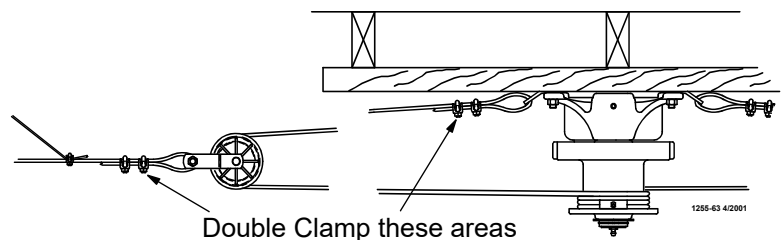

Figure 11. (End View)



Double back arrangement for feed lines over 350' [107 m]

Drop Installation

1. Attach a 3004 Pulley to each hook.
2. Thread the end of the 3/32" or 1/8" cable through the pulley toward the winch. Clamp this end to the 3/16" winch cable about 6" (150 mm) from the last pulley, using a 3/16" cable clamp. See applicable figure; **Figure 3 or 8**.
3. Allow enough cable length for installation of the Adjustment Leveler.
Sufficient cable is included to provide "throwbacks" on drops located beneath and near the winch. Detail "A" in **Figure 1** shows a "throwback" cable arrangement.
4. **Begin installing suspension drops at the winch and proceed to the ends of the feeder line.**
Keep the main cable tight between drops. It may be necessary to hang a weight on the end of the cable to maintain tension on the line.

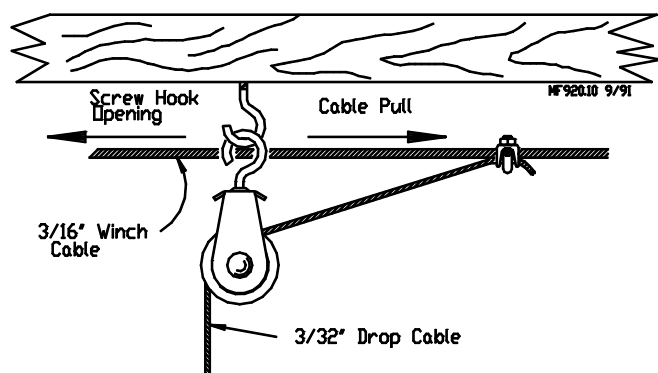
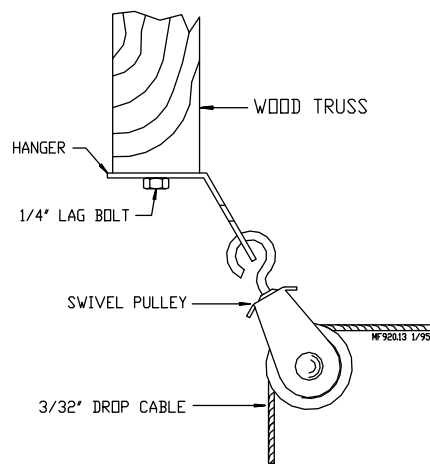

Figure 3. (Side View)



Feeder Assembly Procedure

1. All feeders assemble in the same manor. Refer to **Figure 12** below. Insert the Reduction Tube into the Support Cone and slide the Support Cone Assembly, the Adjustment Cone, and the Grill together as shown in Figure 12. Hook the loop of the Grill to the tab of the Feeder Pan. Rotate the Feeder Pan over on the top of the Grill and Cones. Seat the Feeder Pan in the ring of the Grill. With the Feeder Pan fully seated rotate the pan clockwise to lock in place. Assemble the remaining Feeders.

Typical Pan Assembly

Figure 12

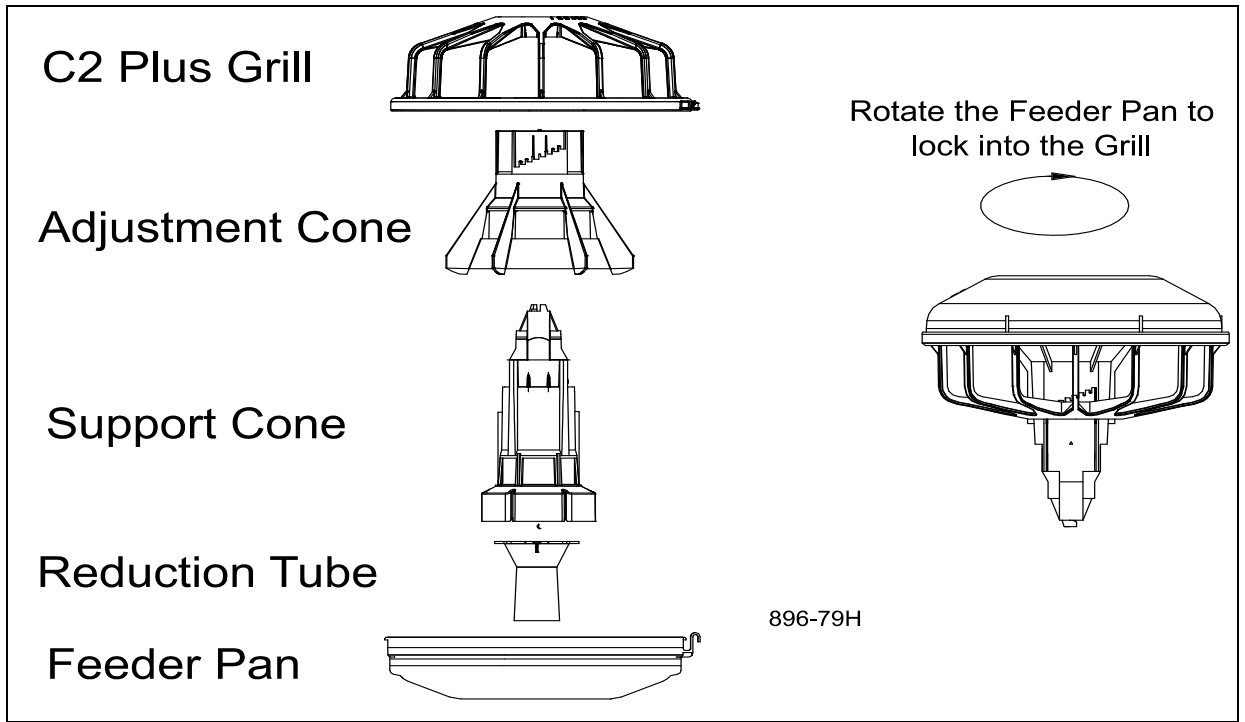

Typical Pan Assembly With Adjustable Grill

Figure 13

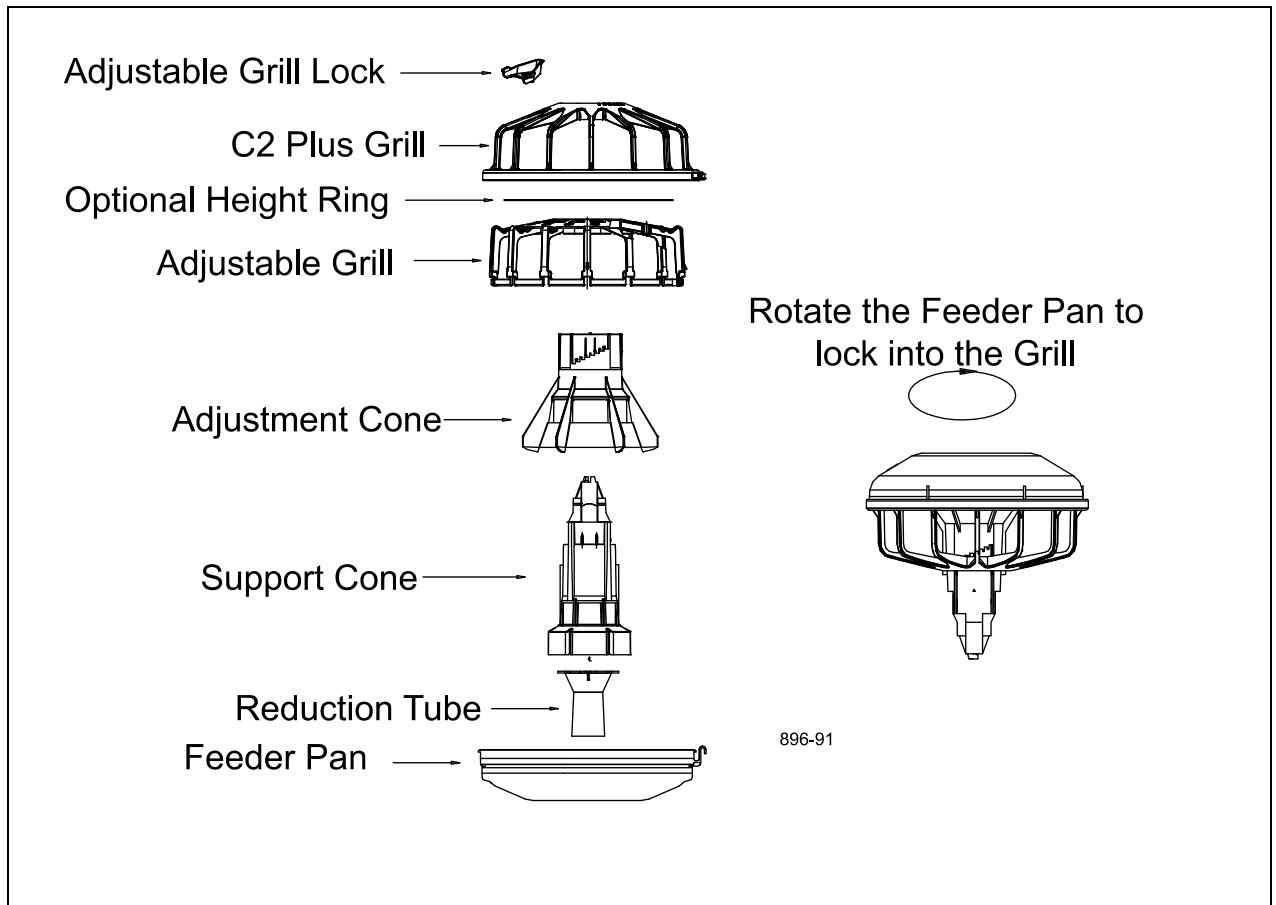

Note: Some applications may use the two-piece Model C2 Plus Feeders. For these applications, the feeders may be installed the same way by assembly the two-piece top onto the feeder assembly before sliding the feeder onto the tube.

2. Slide the pan assembly onto a feeder tube
3. Rotate the auger tubes so that the seam is down, this holds the Pan Assemblies in place on the tubes, as shown in **Figure 17**.
4. Set the pan assemblies at the #4 adjustment position. The arrow molded into the top of the Adjustment Cone should point to the #4 on top of the grill.
5. Beginning at the Hopper/Boot location, position the tube sections (with feeders attached) end-to-end in approximately their final position, with the belled end of the tubes opposite the direction of travel. **See Figure 17**

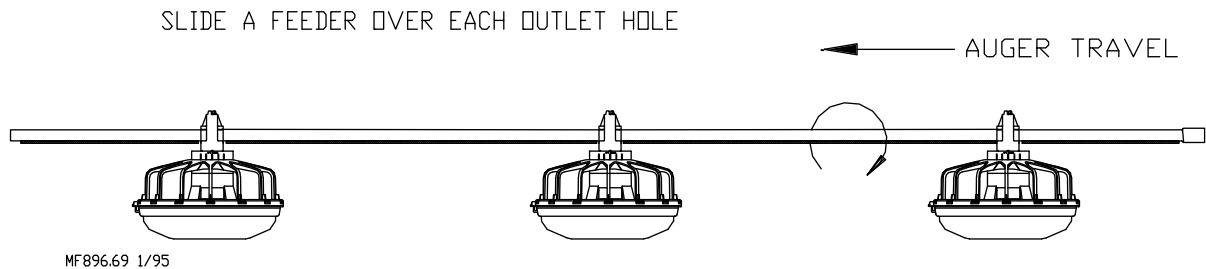

THE PAN ASSEMBLIES ARE HELD IN PLACE BY ROTATING THE TUBES.

Figure 17. (Side View: Standing *outside* the loop.)

Feeder Line Assembly

Note: The auger must travel in a clockwise direction when standing inside the loop.

1. Position the tubes end to end in approximately the final location of the line. The feeder tubes should be installed so that the expanded end of each tube points in the opposite direction of auger travel. **See Figure 18**.

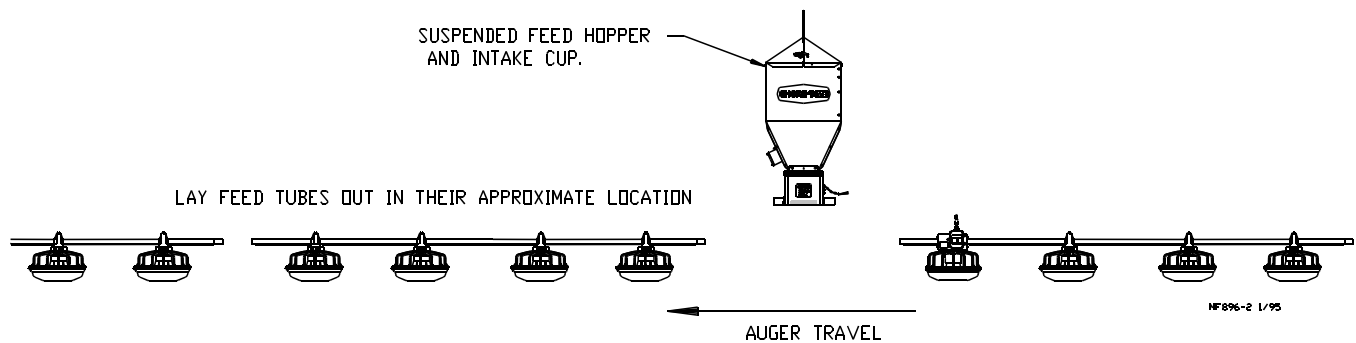

Figure 18. (Side View: Standing *outside* of the loop).

- Two-Hopper systems (systems with over 500' or 152 m total auger length) must have hoppers located as specified in the Planning the System section on page 7 and 8. Skip to step 5 and refer to **Figure 21**.

Single-Hopper systems (systems with less than 500' or 152 m total auger length) may have the hopper located as specified in **Figure 20**.

Chore-Time recommends locating the hopper in the center of the loop, as shown. However, the hopper may be installed at the alternate location specified. Refer to **Figures 22 - 24** for alternate hopper location component layout diagrams.

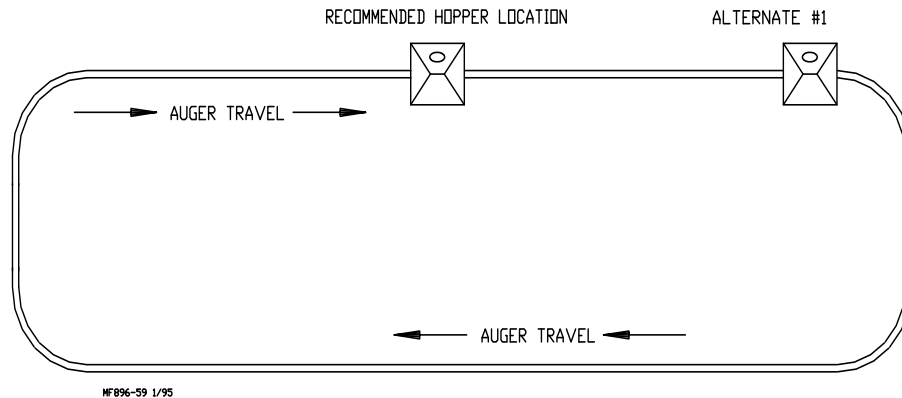

Figure 20. (Top View)

- Beginning at the Boot, assemble the Tube Connector, and Auger Tubes as shown in the appropriate diagram.

Note: The feed tubes should be installed clockwise around the system, starting at the outlet end of one hopper, continuing through the elbows to the incoming end of the other hopper.

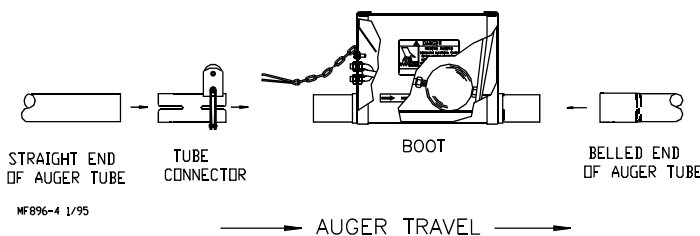

Figure 21. Boot components for Recommended Hopper Location. (Side View: Standing inside the loop).

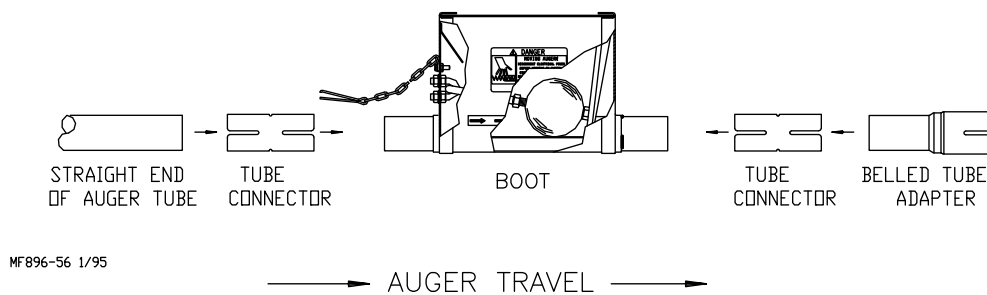

Figure 22. Boot components for Alternate #1. (Side View: Standing inside the loop).

- Continue assembling the feeder line until a power unit location is reached. Refer to section marked "Planning the System" on pages 7 and 8 to determine Power Unit Locations for various system length

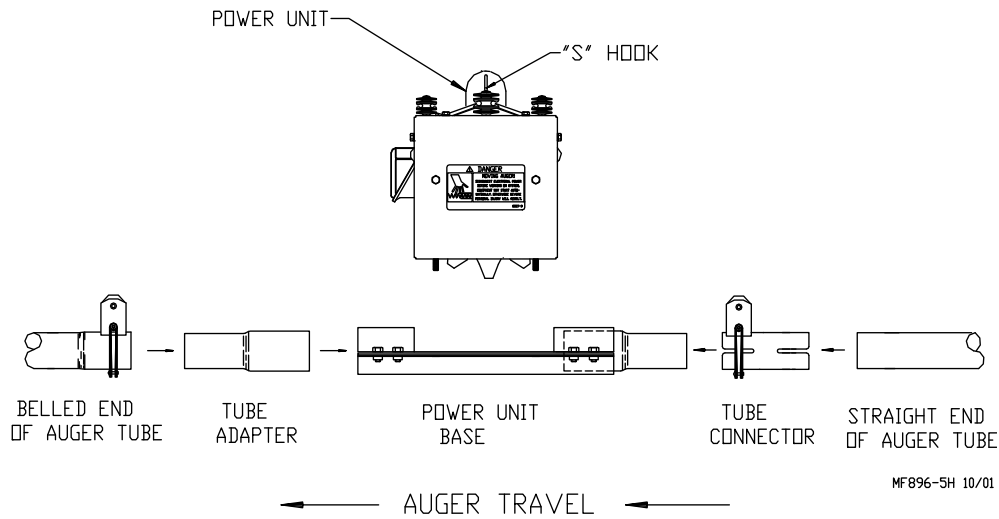

Figure 23. (Side View): Standing outside the loop

- Remove the Power Unit from the Base Connector Weldment and install the Base Connector Weldment, as shown in **Figure 23**.
- Loosen the four bolts on the incoming side of the Power Unit Base.
Slide the belled end of the Tube Adapter into the incoming side of the Power Unit Base. Tighten the four bolts to secure the Tube Adapter to the Power Unit Base. See **Figure 23**.
Use a Tube Connector to connect the incoming straight section of auger tube to the Tube Adapter. Secure using a standard Clamp and an Anti-Roost Clamp.
- Loosen the four bolts on the outgoing side of the Base Connector Weldment.
Slide the belled end of the Tube Adapter into the outgoing side of the Power Unit Base. Tighten the four bolts to secure the Tube Adapter to the Power Unit Base.
- Insert the belled end of the next tube section over the Tube Adapter, as shown in **Figure 23**. Secure using a Clamp/Anti-Roost Bracket.
- Continue installing auger tubes until the elbows are reached.
- Assemble the elbows and related components as shown in **Figure 24**. Temporarily support the elbows until the suspension system is installed.
Install the (10) insulators around the elbows, approximately as shown.

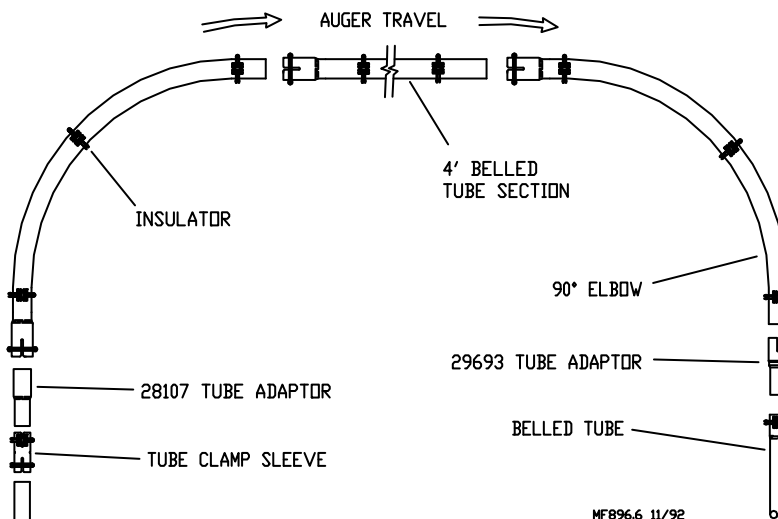

Figure 24. (Side View)

16. Install the remaining auger tubes, power unit bases, hopper, and elbows, the same as the first.

17. **Figure 25** shows the preferred location of the service section.

Cut the belled end of the auger tube leaving 15" (380 mm) between tubes to install the Service Section.

Approximately 4" (100 mm) of the auger tube seam will need to be cut off to allow the Service Section to be installed.

Secure the Service Section Base to the auger tubes by sliding the tubes into the base and fastening the Service Section Clamps on top using the 1/4-20 hardware supplied. Do not install the Service Section Cover at this time.

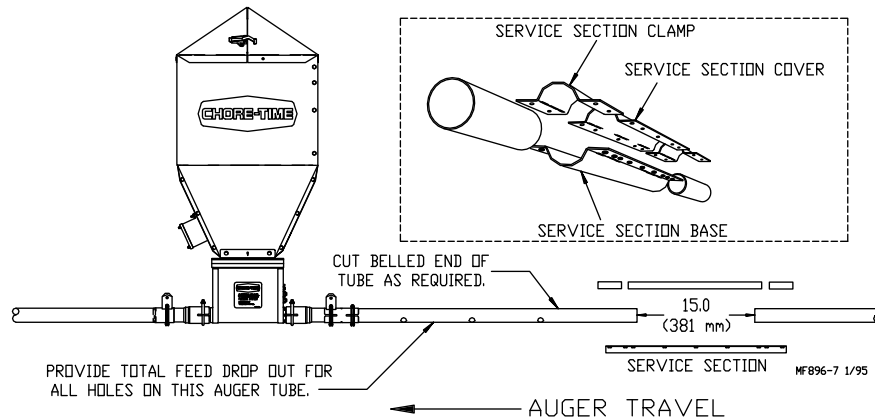

Figure 28. (Side View: Standing outside the loop),

ULTRAPAN Control Feeder

The Proximity Intermediate Control uses a Proximity Switch to sense feed and cause the system to start and stop. The Proximity Switch has sensitivity adjustment and delay adjustment screws. See **Figure 28**.

The Proximity Intermediate Control is to be located just prior to the Feed Hopper. If partial house brooding is to be used, the Intermediate Control must be located on that side of the house next to the hopper on the return side of the feeder.

Do not hinder the bird movement around the Intermediate Control pan. Provide adequate lighting so that the birds will not shy away from the Intermediate Control area.

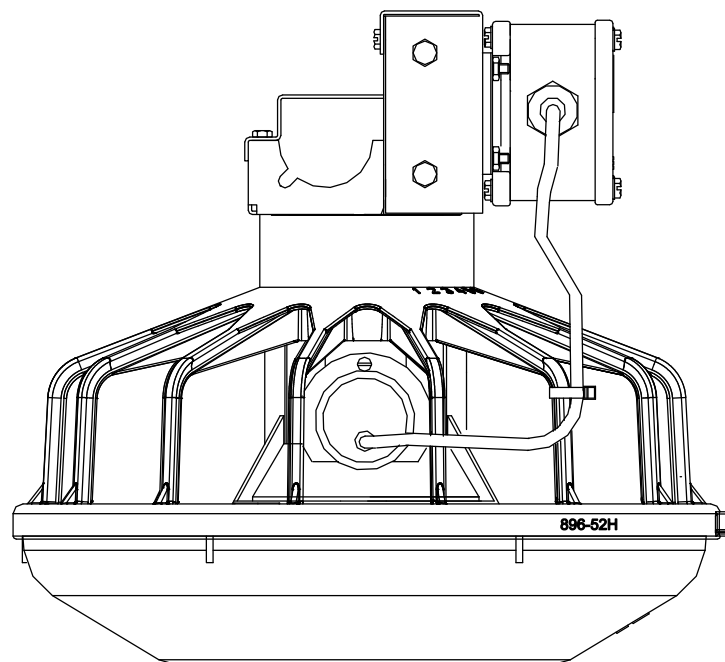

Figure 28.

1. Enlarge the outlet hole where the control is to be installed on the tube. This will ensure total feed dropout to the Intermediate Control. See **Figure 29** for recommended size and placement. Use hacksaw and tin snips to enlarge hole size. Be sure there are no burrs

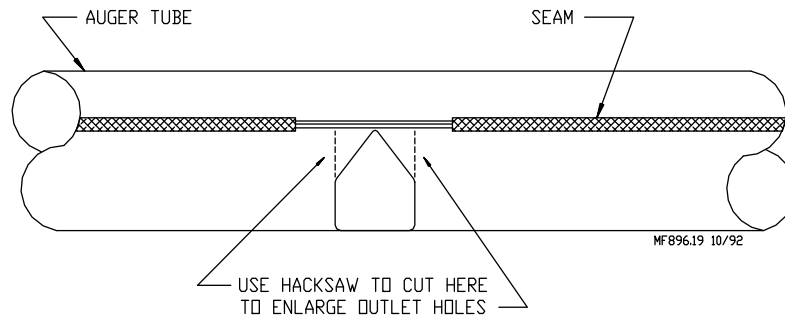

Figure 29. (Side View)

inside the tube to catch the auger.

2. Install the Intermediate Control:
 - a. Remove the two hex head screws on the Control Top.
 - b. Lift off the Control Top.
 - c. Cradle the feeder tube in the control housing. The feeder tube may have to be turned to allow the pan to hang straight.
 - d. Clamp the control in place by inserting tabs on the Control Top into the slots on the Control Body. Install and tighten the two hex head screws that were removed earlier.

Figure 30 shows an Intermediate Control installed in the appropriate location.

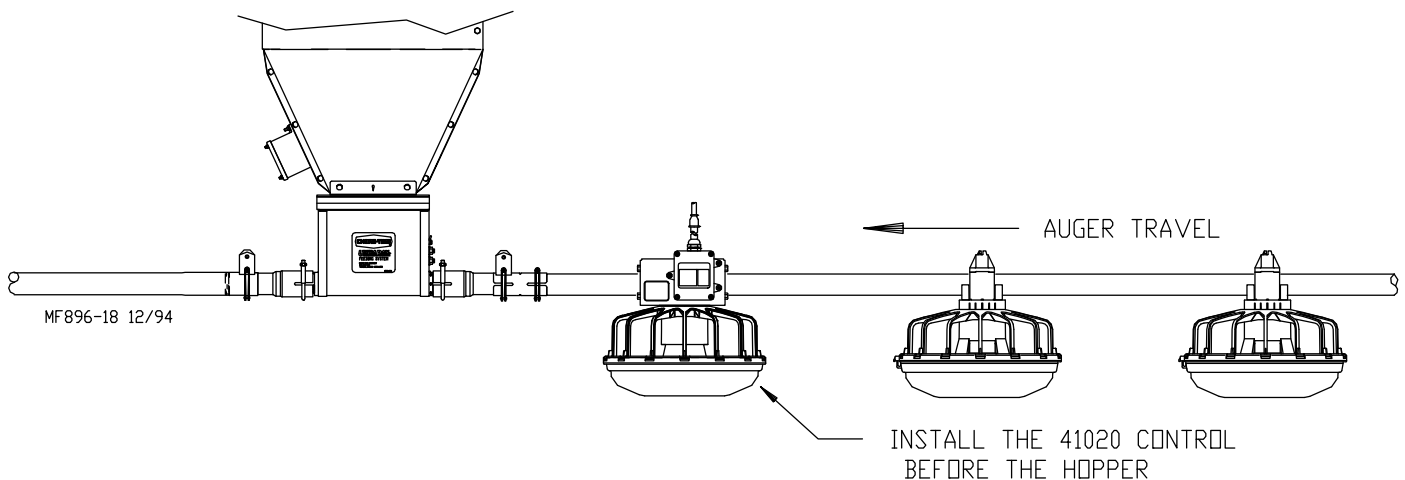

Figure 30. (Side View: Standing *outside* the loop).

Adjustable Hanger Installation

The Adjustable Hanger used with the ULTRAPAN Feeder enables the operator to index the feeder line. Use the chart on **page 30** to determine hanger settings for your installation.

Note: The chart on **page 30** is for use on standard (2) hopper systems where the hoppers are located near the center of the feeder loop.

Figure 32 shows how the setting numbers (C1, C2, etc.) from the chart relate to the Adjustable Hanger. Example: The Hanger in **Figure 32** is set to "D5."

Install the adjustable hanger to each tube at the suspension drop location. Use the appropriate Indexing Chart on **page 30**, to determine proper hanger setting for each individual tube as it is being installed.

Important

When installing the Hangers, make sure;

- 1) to work in the direction of auger travel, **and**
- 2) the stamped numbers are facing the outgoing side of the hopper

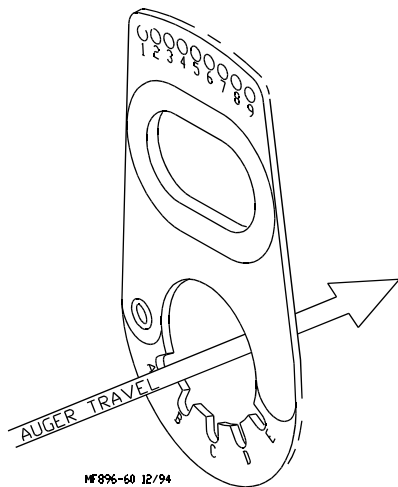

Figure 31.

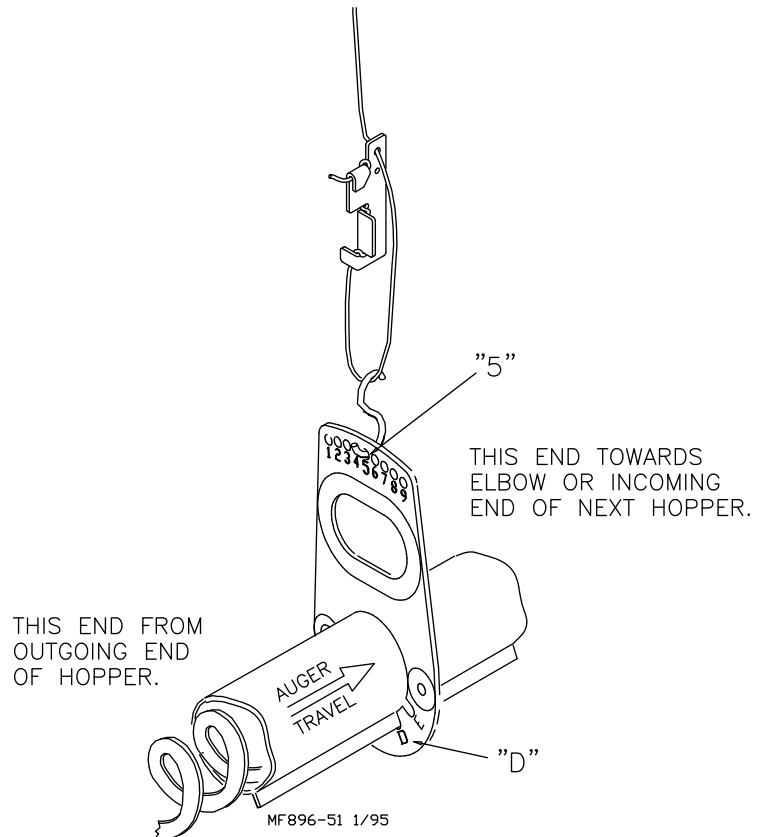

Figure 32.

Note: The Hanger **MUST** be installed properly for the system to properly dispense feed into the feeder pans.

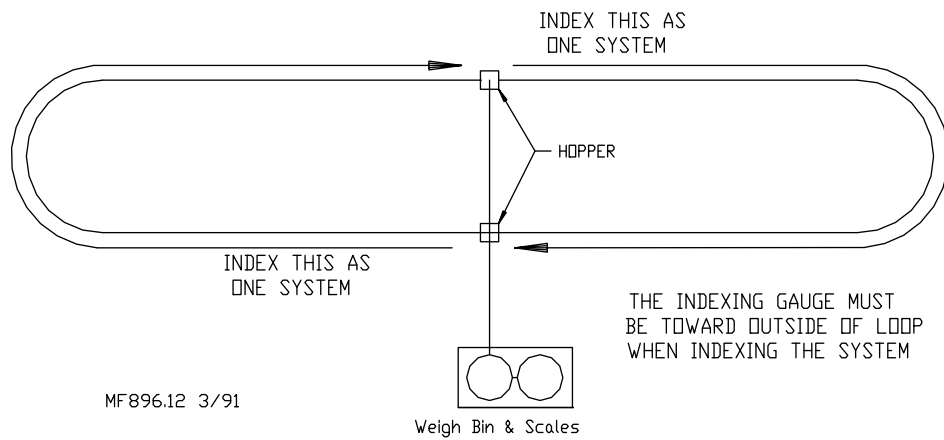

Figure 33. (Top View)

Indexing the Tubes

Beginning at the hopper, use a marker to number the feeder tubes. Begin with Tube 1 coming out of the hopper, then 2, 3, and so on, continuing until each tube in the line is marked. Do not include elbows in tube count.

The maximum number of tubes for systems using **9' Auger Tubes** is 56. The maximum number of tubes for systems using **10' Auger Tubes** is **50**. The maximum number of tubes for systems using **12' Auger Tubes** is **42**.

Find the heading for the number of tubes on the feeder line in the horizontal line at the top of the indexing chart. The correct hanger adjustments for each feeder tube are shown in the column under the appropriate heading.

Installing Tube Clamps and Anti-Roost Brackets

Beginning at the boot, place a clamp/anti-roost bracket on the first tube connection. For 9-ft.[2.7m] and 10ft.[3m] feeder tubes; place a standard clamp on the next four tube joints-then use a clamp/anti-roost bracket on the fifth.

For 12ft.[3.6m] feeder tubes; place a standard clamp on the next three tube joints-then use a clamp/anti-roost bracket.

Do not tighten the clamps at this time.

Continue installing the clamps and anti-roost brackets using the above spacing procedure. Anti-roost brackets are used on each side of the drive units and at the elbows so the spacing procedure will be repeated again following these components. Install clamps to the entire system.

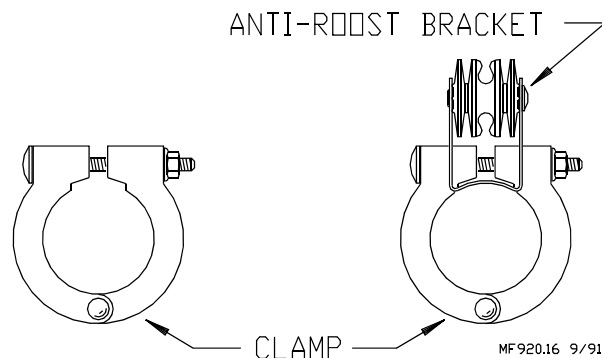

Figure 34. (Side View)

Auger Installation

Note: Use extreme caution when working with the auger. The auger is under tension and may spring causing personal injury. Wear protective clothing, gloves, and safety glasses when working with the auger.

To avoid kinking the auger, be careful not to drop the rolled auger when handling. Inspect the auger carefully as it is installed. Small kinks may be straightened. Large kinks must be removed and the auger brazed back together.

Cut the leading 18"[450mm] and last 18"[450mm] off each roll of auger. Also, cut out any other destroyed auger sections and reconnect the auger as specified in the Auger Connector or Auger Brazing section of this manual.

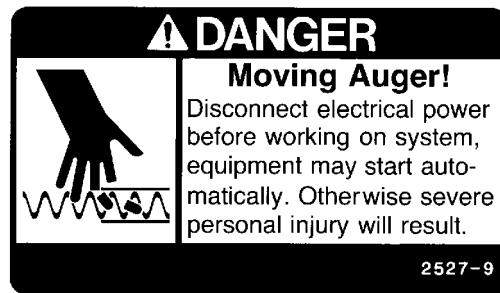

In preparation for the auger installation, complete the following:

- The Power Unit and Driver Assemblies) must be removed from the Base Connector Weldment. An Auger Driver must be installed on each Base Connector Weldment. See **Figure 35**.
- The Service Section Cover must be removed to install the auger.

1. Begin feeding one end of the auger into the auger tubes through the Service Section.

Chore-Time recommends always feeding the auger into the tubes from the outside of the coil (this has a plastic cap on the end of the auger.) This will insure the auger flightings will match.

Push the auger, by hand, to the first Auger Driver. The Auger Driver may then be used to pull the auger through the tubes. An Auger Driver should be installed at each motor location to aid in pulling the auger around the system. See **Figure 35**.

2. If more than one auger is to be installed, the tail end of the first auger and the leading end of the second auger must be connected with an Auger Connector.

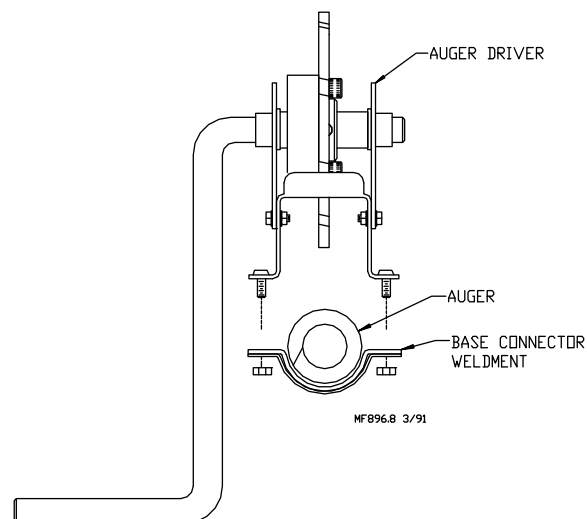
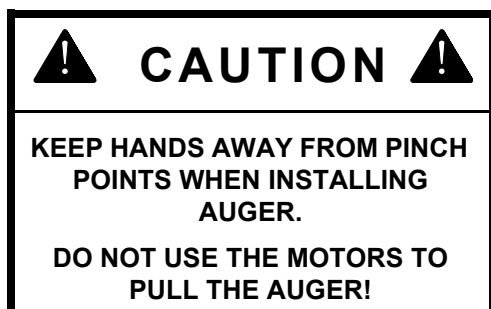

Figure 35. (End View)

3. Continue installing auger until it reaches the Service Section.
4. Cut excess auger off coil, Leave enough auger to work with when stretching and connecting the auger.
5. Pull on one end of the auger until the other end moves. Release the auger and allow it to relax to it's free length.
6. Use locking pliers to hold one end of auger in place while stretching the auger. See **Figure 36**.

Allow approximately 4" to 6" (100 to 150 mm) of auger to extend past the locking pliers to allow for Auger Connector (or brazing) installation.

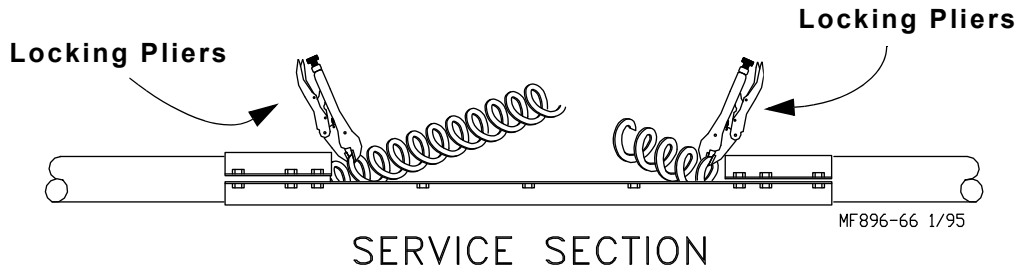

Figure 36. (Side View)

7. Determine the amount of stretch required.
The amount of stretch required is 6" per 100' (150 mm per 30 m) of total system length.
For example: If the system has an overall system length of 300' (91.4 m), the required auger stretch is 18" (460 mm).
8. From the relaxed position, stretch the auger (as determined by step 7, above) by pulling on the loose end.
9. Mark the auger where it is to be cut.
10. Pull another 18" (450 mm) of auger and install another set of locking pliers to keep the auger from springing back into the auger tube. See **Figure 31**.
11. Cut the auger at the mark. File the end of the auger smooth so that there are no sharp edges.

Make sure the auger is not deformed or twisted from cutting. Deformed auger will not match well with the other end of the auger and may cause problems passing through Drive Units.

Auger Connector Installation

The Auger Connector is designed to fasten the ends of ULTRAPAN Auger together without welding. *NOTE: It is not to be used with rotating auger system.*

1. Screw the Auger Connector into one end of the auger.
2. Untwist the remaining end of the auger 1-1/2 turns so that when it is threaded into the first end of the auger it will return to its relaxed position. Auger ends must be overlapped—NOT butted, when threaded into the track of the Auger Connector. See **Figure 36**.

Figure 36. (Side View)

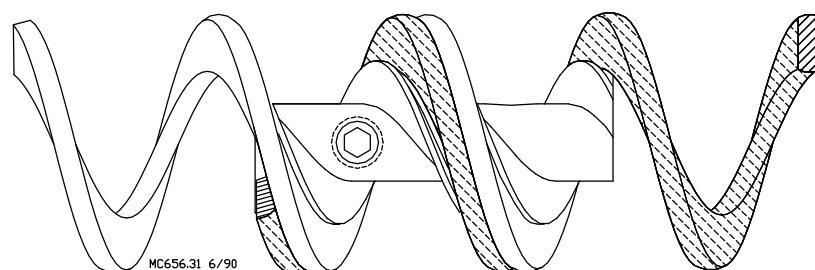

3. Stretch the auger and twist the auger ends together. Both ends of the auger should be even with the end of the Auger Connector.
4. Tighten each set screw until it touches the auger, then tighten an additional 3/4 turn **MAXIMUM**.

Be careful not to over tighten the setscrews and deform the auger. Over tightening the setscrews may cause the auger to jam up in the power units.

5. File both ends of the auger so that they are the same diameter as the rest of the auger.

Alternative Auger Connection - Auger Brazing

The feeder auger may be brazed according to these instructions to obtain a strong joint.

Screw the auger together about 120 degrees (1/3 turn) and secure in the Welding Fixture. See **Figure 37**.

Slowly heat the auger and apply a braze to the **inside** of the auger. Allow it to cool slightly, then rotate the Welding Fixture and braze the **outside** of the auger.

The braze should extend from 1/8" to 1/4" (3 to 6 mm) from the end of each auger. **DO NOT BRAZE ALL THE WAY TO THE END.** This allows the auger to flex in either direction as it travels around the elbows without becoming weakened. See **Figure 38**.

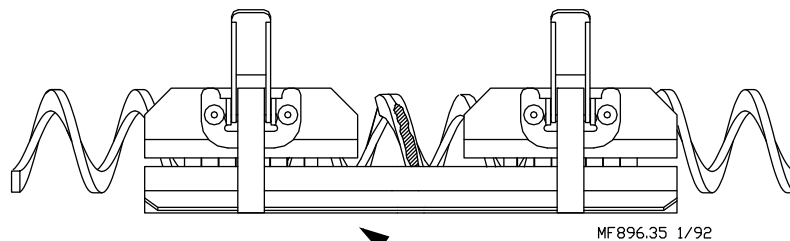

Figure 37. (Side View)

Welding Fixture

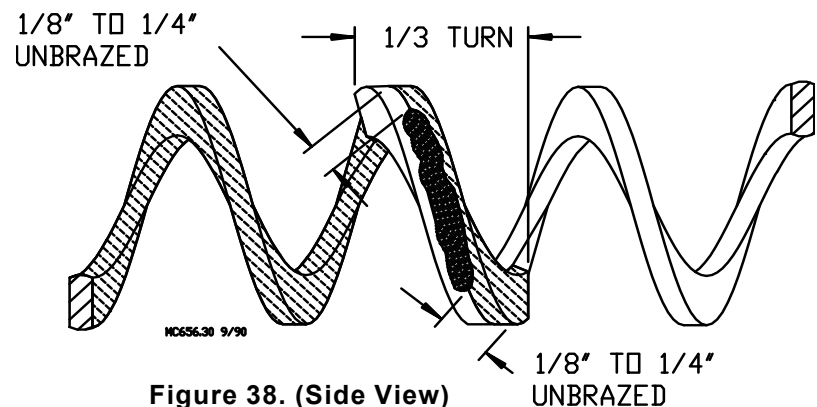

Figure 38. (Side View)

THINGS TO REMEMBER

- To insure a good braze, clean dirt, oil, etc., off both ends of the auger.
- A bronze, flux coated filler rod is recommended.
- The joint should be smooth and well filled.
- Do not over heat the auger; apply just enough heat to melt the filler rod.
- Allow the auger to air cool.
- File all edges smooth.
- The outside diameter of the auger at the braze should not be larger than the rest of the auger.

Suspending the Feeder

1. Assemble the hopper to the boot using the bottom rails of the hopper, as shown in **Figure 39**. Hardware (1/4-20) is supplied to hold the boot in place on the hopper rails.
2. A Cable assembly (including 20ft.[6m] of cable, a sleeve clamp, and a 5/32" thimble) is supplied to suspend the hopper. **Figure 39** shows the suspension components assembled. The pin should be located through the top hole of the adjustment brackets.

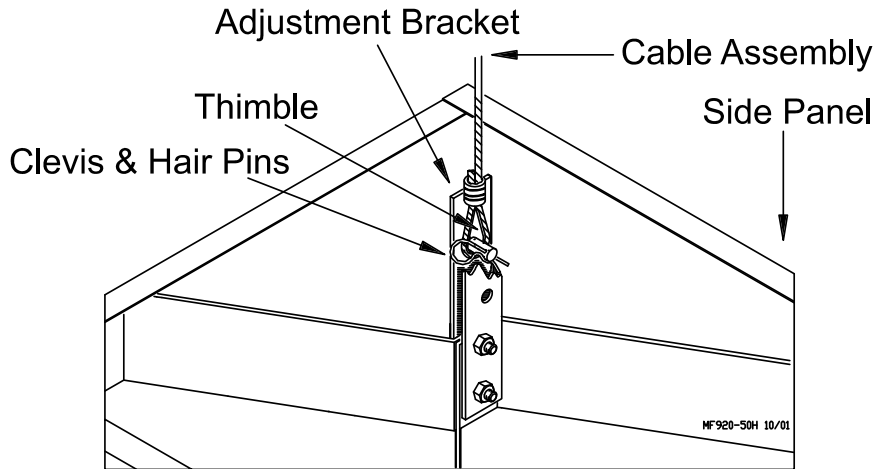

3. Lift the hopper and boot assembly up to the point the feed pans just clear the floor. Block **Figure 39**. (Tope View of Hopper)

up the boot to this position.

4. Feed the free end of the hopper support cable through the hopper suspension pulley, pull the cable to remove the slack, and attach to main cable. Cable will now support the hopper and block can be removed.
5. Install the tube support kit as shown in **Figure 40**. The drop tube is supplied with the fill system.

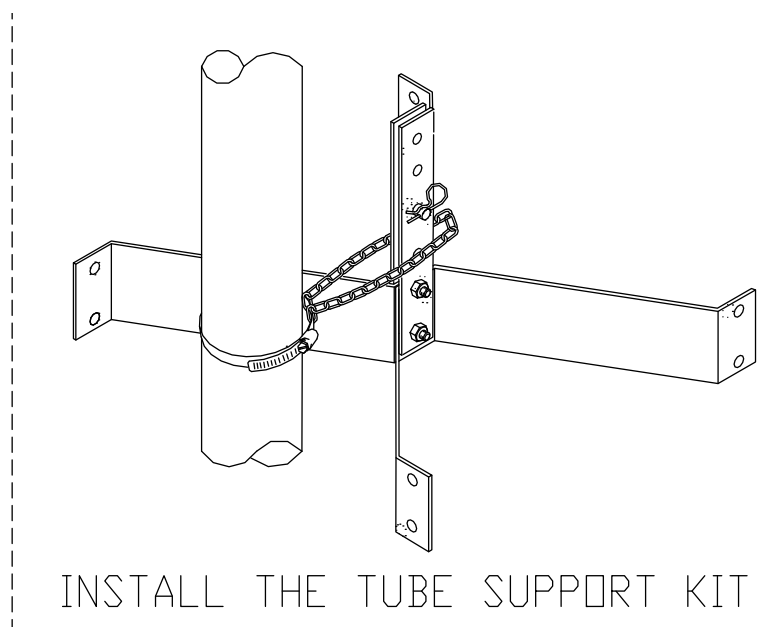

Figure 40.

- Starting at the hopper (winch if the hopper is placed at the end of the building), begin suspending the feeder tubes by using the cable adjuster and drop cable. **Figure 42 shows the proper use of the cable adjuster.**

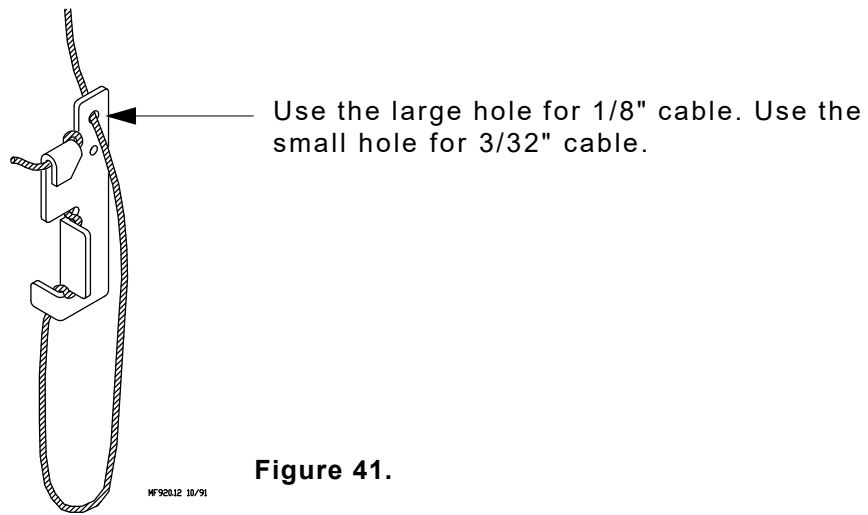

Figure 41.

- Use the index chart on page 30 to determine the proper setting to place the cable through the adjustable hangers. **Figure 42 shows** how the setting numbers (C1, C2, etc.) from the chart relate to the adjustable hanger. Example: the hanger in **Figure 42** is set to "D5".
- As the cable is attached to each adjustable hanger, raise the feeder tube until the feeder

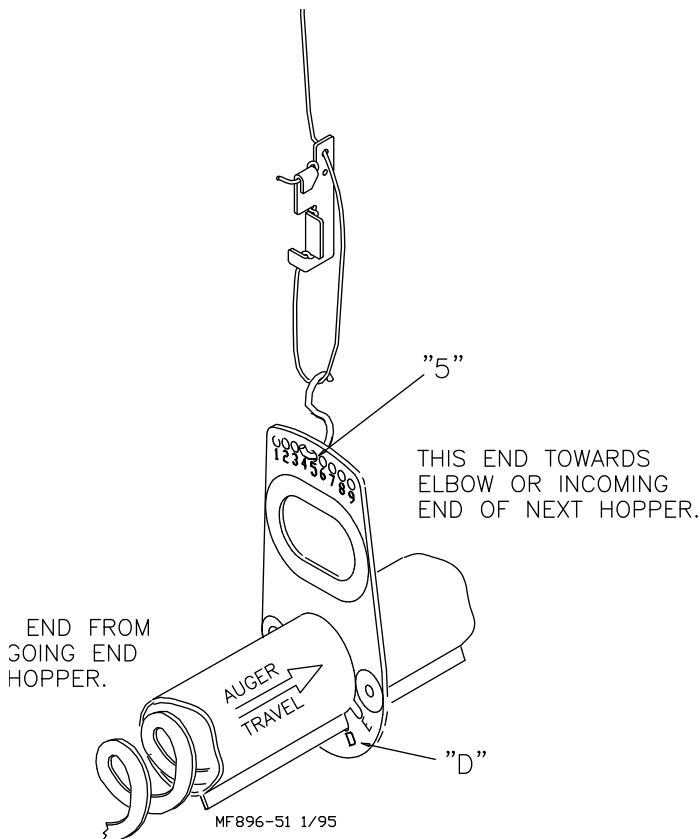

Figure 42.

just clear the floor. This procedure will remove the slack cable as you proceed to each end of the system.

9. Attach the cable suspension system to the drive units and elbows. Additional suspension drops must be installed to support the drive units and elbows as shown in the Suspension Layout Graphic, **Figure 1**, Page 10. Use the #4207 hanger to support the elbows.
- 10 Following installation of all drops, check the drop cables before raising feeder lines. Cable must be properly tracking on all pulley before raising the feeder line.
11. Raise the feeder line to a convenient working height.
12. With the feeder line suspended, measure from the floor or ceiling to the auger tubes to level the system. Make sure each tube is level (not sagging, sloping, etc.).

Indexing the Tubes

Note: When indexing the tubes, index from the outgoing side of one hopper, around the elbows to the incoming side of the next hopper. Repeat the procedure on the remaining section of tubes and elbows. See **Figure 33**.

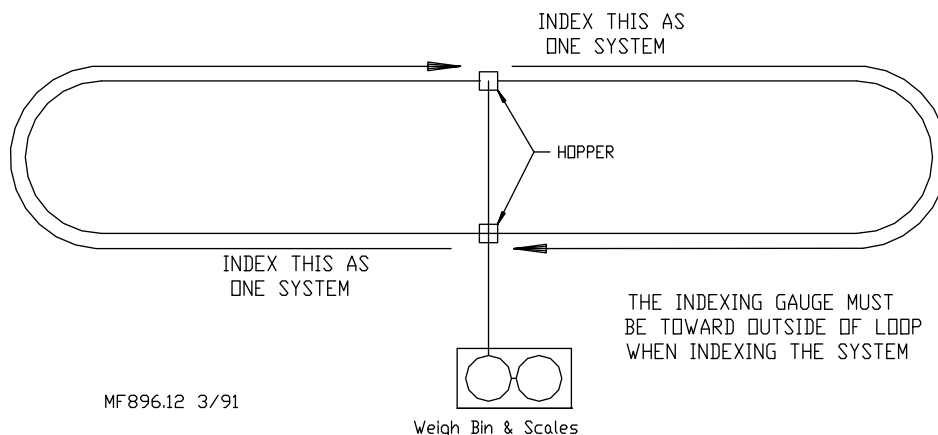

Figure 33. (Top View)

1. **Leave the tube clamps loose, until the line has been indexed.**
2. Use the chart (page 30) for indexing the tubes.
Find the heading for the number of tubes in your feeder line in the horizontal line at the top of the indexing chart. The correct hanger adjustments for each feeder tube are shown in the column under the appropriate heading.
3. The Adjustable Hangers have been set during the suspension process, Check the setting with the Indexing Gauge to fine tune the line.
Start at the hopper. Standing down the feeder line looking back at the outgoing end of the hopper, the indexing gauge should be placed with the notch over the crimped portion of the tube with the gauge on the right side of the feeder tube (Indexing Gauge will be outside the loop). The Indexing Gauge should be placed between the second and third hole on the first tube.

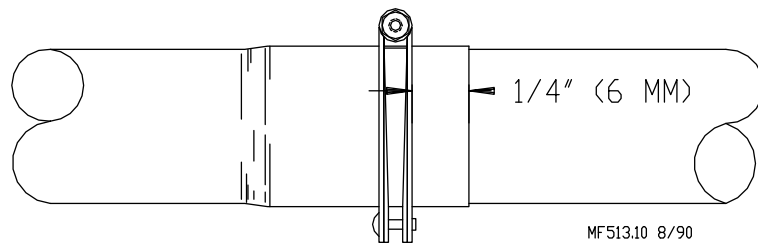

Figure 43. (Side View)

5. Starting with tube number 1, set the clear pointer on the gauge to the proper setting according to the indexing chart. Rotate the tube until the bubble in the leveler comes to the center. Install and tighten the clamp, as shown in **Figure 43**, on the bell toward the hopper.

NOTE: If the tube must be rotated so much that the Adjustable Hangers are tilted too far to one side or the other, check the following:

- a. Make sure the Adjustable Hanger is set according to the indexing chart on page 30.
 - b. Make sure the Indexing Gauge is properly positioned on the tube. The Indexing Gauge must always be to outside the loop. It is common **mistake** to switch the Indexing Gauge to be located inside the loop after a corner.
 - c. Make sure the Indexing Gauge is placed on the tube correctly. See point 4.
 - d. Make sure that the settings for both the Indexing Gauge and the Adjustable Hangers are taken from the correct column from the chart for length of auger tube being indexed.
6. Continue to set the remainder of the line in the same manner. After each tube has been set, tighten the clamp on the belled end toward the hopper. Take care to insure that the tubes already set, do not move. (This will require a second person to hold the end of the tube that has just been set while you turn the next tube to be set.)

Position the clamps on the tube joints, as shown in **Figure 43**.

NOTE: When rotating the tubes, hold the tubes already indexed from moving. Use two large adjustable pliers or pipe wrenches to grip the tube. Be careful not to deform the tubes.

7. Install Anti-Swing Camps.

Indexing Chart for ULTRAPAN Feeders

For standard (2) hoppers systems.

Number Of Tubes

	12	14	16	18	20	22	24	26	28	30	32	34	36	38	40	42	44	46	48	50	52	54	56								
1	C1	C1	C1	C1	C1	C1	C1	C1	C1	B8	B8	B8	B8	B8	B8	B8	B7	B6	B6	B6	B6	B6	B6	1							
2	C2	C2	C2	C2	C1	C1	C1	C1	C1	C1	B8	B8	B8	B8	B8	B8	B8	B7	B6	B6	B6	B6	B6	2							
3	C3	C2	C2	C2	C2	C2	C2	C2	C2	C1	C1	C1	C1	C1	B9	B9	B8	B7	B7	B6	B6	B6	B6	3							
4	C4	C3	C3	C3	C2	C2	C2	C2	C2	C2	C1	C1	C1	C1	C1	B9	B9	B8	B7	B7	B7	B7	B7	4							
5	C5	C3	C3	C3	C3	C3	C3	C3	C3	C2	C2	C2	C2	C1	C1	B9	B9	B8	B7	B7	B7	B7	B7	5							
6	C6*	C4	C4	C4	C3	C3	C3	C3	C3	C3	C2	C2	C2	C2	C1	C1	B9	B8	B8	B7	B7	B7	B7	6							
7	C7	C5*	C4	C4	C4	C4	C4	C4	C4	C3	C3	C3	C2	C2	C2	C1	C1	B9	B8	B8	B8	B8	B8	7							
8	C8	C6	C5*	C5	C4	C4	C4	C4	C4	C4	C3	C3	C3	C2	C2	C1	C1	B9	B8	B8	B8	B8	B8	8							
9	D2	C7	C5	C5*	C5	C5	C5	C5	C5	C4	C4	C4	C3	C3	C2	C2	C1	B9	B9	B8	B8	B8	B8	9							
10	D3	C8	C6	C6	C5*	C5	C5	C5	C5	C5	C4	C4	C3	C3	C3	C2	C2	C1	B9	B9	B9	B9	B9	10							
11	D4	D2	C7	C6	C6	C6*	C6	C6	C6	C5	C5	C4	C4	C3	C3	C2	C2	C1	B9	B9	B9	B9	B9	11							
12	D5	D3	C8	C7	C6	C6	C6*	C6	C6	C5	C5	C5	C4	C4	C3	C3	C2	C1	C1	B9	B9	B9	B9	12							
13		D4	D2	C8	C7	C7	C7	C6*	C6	C6	C5	C5	C4	C4	C4	C3	C3	C2	C1	C1	C1	C1	C1	13							
14		D5	D3	D1	C7	C7	C7	C7	C6*	C6	C6	C5	C5	C4	C4	C3	C3	C2	C1	C1	C1	C1	C1	14							
15			D4	D2	C8	C8	C8	C7	C7	C6*	C6	C5	C5	C4	C4	C3	C2	C2	C1	C1	C1	C1	C1	15							
16			D5	D3	D1	C8	C8	C8	C7	C7	C6*	C6	C5	C5	C4	C4	C3	C2	C2	C2	C2	C2	C2	16							
17				D4	D2	D1	D1	C8	C8	C7	C7	C6*	C6	C5	C5	C4	C4	C3	C2	C2	C2	C2	C2	17							
18				D5	D3	D1	D1	D1	C8	C7	C7	C7	C6*	C6	C5	C5	C4	C3	C3	C2	C2	C2	C2	18							
19					D4	D2	D2	D1	C8	C8	C7	C7	C6	C6*	C6	C5	C5	C4	C3	C3	C3	C3	C3	19							
20					D5	D3	D2	D2	D1	C8	C8	C7	C7	C6	C6*	C5	C5	C4	C3	C3	C3	C3	C3	20							
21						D4	D3	D2	D1	C8	C8	C8	C7	C7	C6	C6*	C5	C4	C4	C3	C3	C3	C3	21							
22							D5	D3	D3	D2	D1	C8	C8	C7	C7	C7	C6	C6*	C5	C4	C4	C4	C4	22							
23								D4	D3	D2	D1	D1	C8	C8	C7	C7	C6	C6	C5*	C4	C4	C4	C4	23							
24									D5	D4	D3	D2	D1	D1	C8	C8	C7	C6	C5	C5*	C4	C4	C4	24							
25										D4	D3	D2	D1	D1	C8	C8	C8	C7	C7	C6	C5	C5*	C5	25							
26											D5	D4	D3	D2	D1	D1	C8	C8	C7	C7	C6	C5	C5*	26							
27												D4	D3	D2	D2	D1	D1	C8	C7	C6	C5	C5*	C5	27							
28													D5	D4	D3	D2	D1	D1	C8	C8	C7	C6	C5	C5*	28						
29															D4	D3	D2	D2	D1	D1	C8	C8	C7	C5	29						
30																D5	D4	D3	D2	D2	D1	D1	C8	C6	30						
31																		D4	D3	D2	D2	D2	D1	C8	C6	31					
32																			D5	D4	D3	D2	D2	D1	C8	C6	32				
33																				D4	D3	D3	D2	D2	D1	C8	C6	33			
34																					D5	D4	D3	D3	D2	D1	C8	C6	34		
35																						D4	D3	D3	D2	D2	D1	C8	C6	35	
36																							D5	D4	D3	D3	D2	D1	C8	C6	36
37																														37	
38																														38	
39																														39	
40																														40	
41																														41	
42																														42	
43																														43	
44																														44	
45																														45	
46																														46	
47																														47	
48																														48	
49																														49	
50																														50	
51																														51	
52																														52	
53																														53	
54																														54	
55																														55	
56																														56	

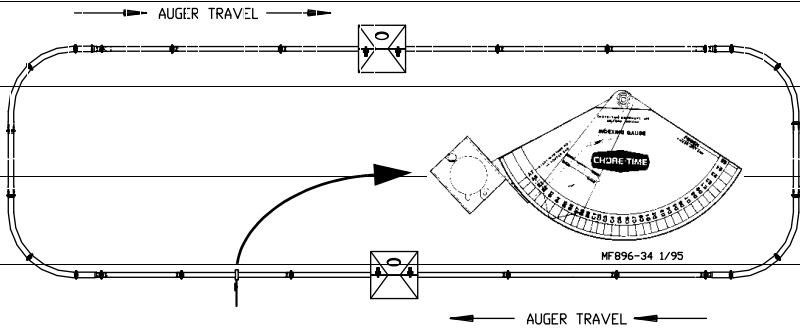

* Represents Center Of Elbows

Anti-Roost Installation

1. Unroll the bulk anti-roost cable. Note: If the cable is unrolled as shown in **Figure 44**, taking 5 loops of the coil with one hand, then changing hands to remove 5 loops as it is unrolled, it will lie flat during installation.

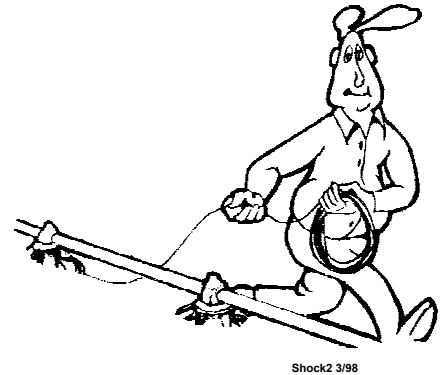

Figure 44. Unrolling the Cable

2. Start at the hopper end of the line and form a loop around the anti-roost bracket. For best results, make a double loop around the anti-roost insulator in the center groove of the insulator and fasten with a 1/16" cable clamp as shown in **Figure 45**.
3. Insert the cable in the insulator on the top of each Grill Support between the hopper and the next anti-roost bracket.

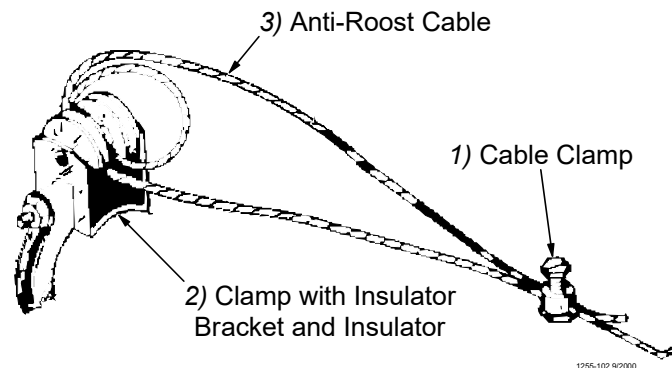

Figure 45. Anti-Roost Cable at the Hopper

4. Attach a spring in the center groove at the second anti-roost bracket and cut the cable at this point. See **Figure 46**.
5. Thread the ends of the cable through the end of the spring. Pull the cable tight so that there is 3/4" to 1" [20 to 25 mm] of stretch in the spring. Clamp the cable to form a loop and cut off any excess. See **Figure 46**.

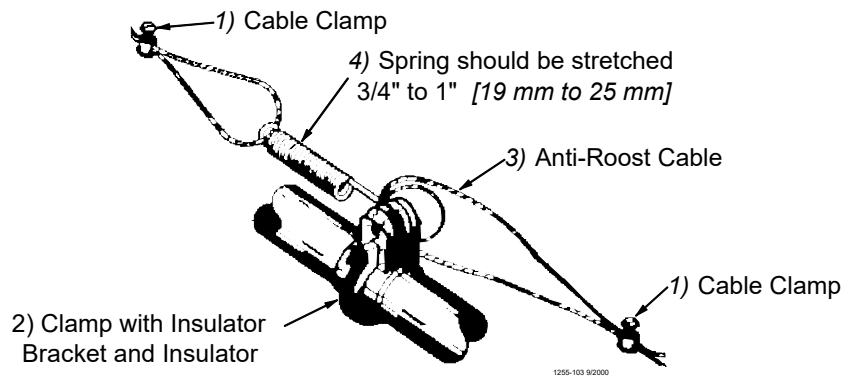

Figure 46. Anti-Roost Cable Mid-Line Connection

6. Attach the cable to the insulator. For best results, make a double loop around the anti-roost insulator in the center groove of the insulator and fasten with a 1/16" cable clamp as shown in **Figure 46**.
7. Run the cable to the next insulator, attach a spring in the center groove at the anti-roost bracket and cut the cable at this point. The cable should be positioned in the insulator built into the top of each grill support along the feeder line.
8. Repeat this installation along the entire feeder line to the drive units and elbows.

9. Install the Anti-Roost Guard on the power unit insulators. Be sure the wire snaps into the retainers molded into the insulators.
10. Pull the cable tight so that there is 3/4" to 1" (19 to 25 mm) of stretch in the spring. Clamp the cable to form a loop. Thread the excess cable through the spring and clamp to Anti-Roost Wire. See **Figure 47**.
11. Attach the cable to the insulator on the outgoing side of the power unit. For best results, make a double loop around the center groove of the Anti-Roost insulator and fasten with a 1/16" cable clamp as shown in **Figure 47**.

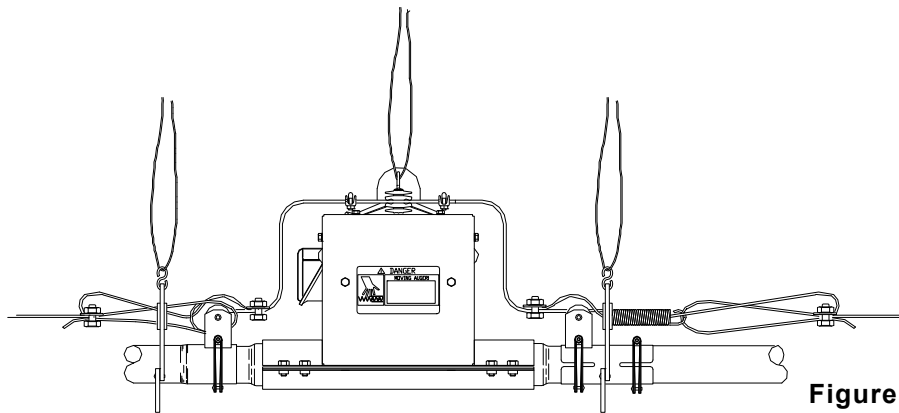

Figure 47. (Side View)

MF896-13 1/95

12. Run the cable to the next Anti-Roost Clamp. Attach a spring in the center groove at the Anti-Roost Bracket and cut the cable at this point. The cable should be positioned in the insulator built into the top of each Grill Support along the feeder line.
13. Repeat this installation until the Anti-Roost cable is installed along the feeder line, until a corner is reached.
14. Anti-Roost Clamps must be installed around the elbows, as shown in **Figure 48**.

The Anti-Roost Wire is provided to be used around the elbows. Snap it down in the center groove of the insulators on the elbows, and on the insulators immediately before and after the elbows. See **Figure 48**.

Install a jumper wire from the shocker cable to the Anti-Roost Wire, using a cable clamp, supplied.

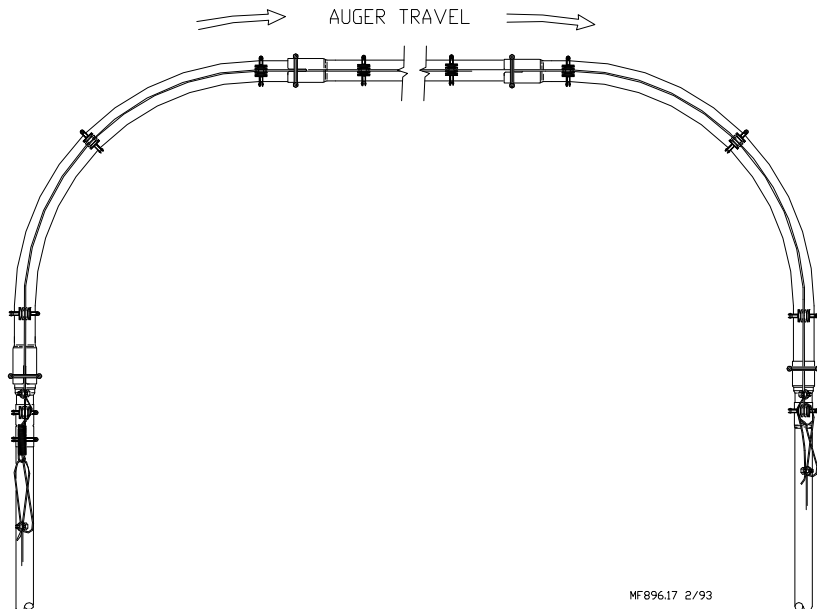

Figure 48. (Top View)

MF896.17 2/93

15. Continue installing the Anti-Roost cable, spring, etc., similarly around the system.
16. Install the high-voltage wire from the insulator on one side of the boot to the insulator on the other side of the boot. See **Figure 49**.

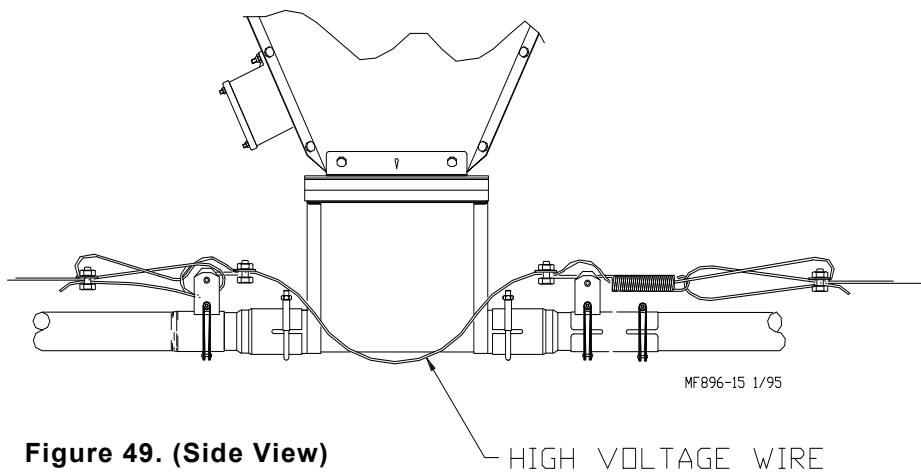

Figure 49. (Side View)

17. Attach the Line Charger to the side of the feeder tube with two tube clamps, included in the parts package. Connect the charge cable to the Anti-Roost line using the cable clamp supplied. See **Figure 50**.

Use only the voltage listed on the Line Charger to operate it. Provide some means of disconnecting the power to the Line Charger; a switch near the door to the building is a good idea, or plug and receptacle may be used.

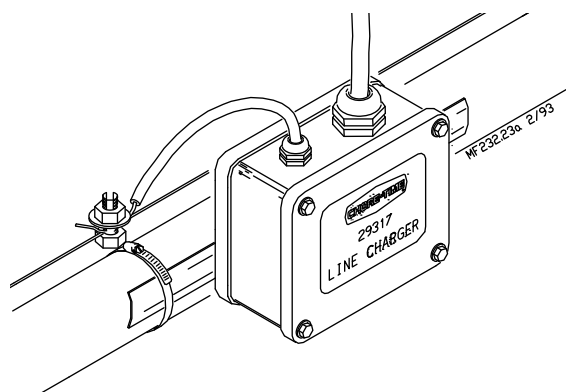
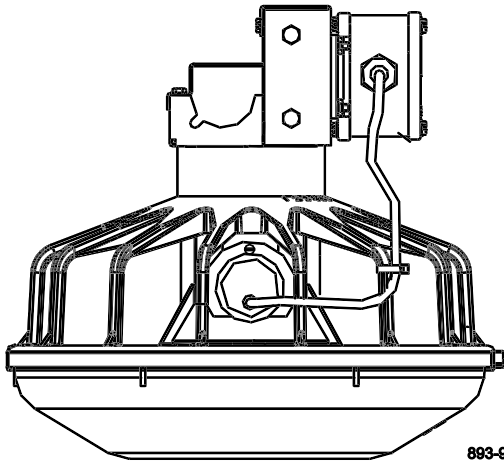

Figure 50.

Proximity Intermediate Control

**Part #41020
Deep**



**Part #42016
Shallow**

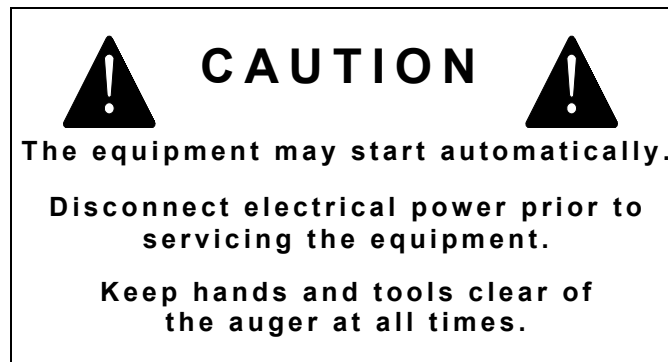
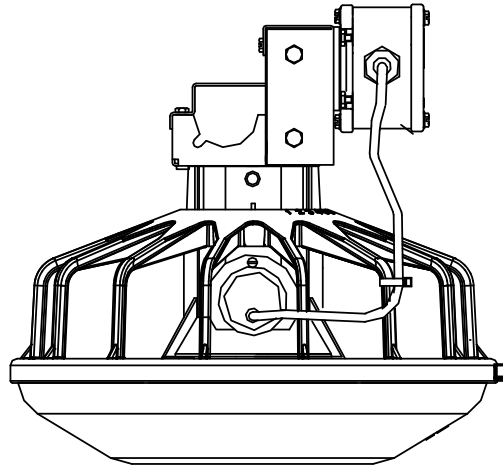

Introduction

The Proximity Intermediate Control w/Off Delay was designed to provide improved feeding in ULTRAPAN® Breeder Feeder Systems.

Do not hinder bird movement around the Intermediate Control. Provide adequate lighting so that the birds will not shy away from the Intermediate Control.

Operation

When the switch senses feed, the Delay is activated immediately. The system will continue to run until the delay has expired. When feed is removed, the system is activated.

Setting the Delay

The Proximity Switch includes an adjustable delay. The delay may be set from 1 second to 10 minutes.

- A. Use a small screw driver provided to turn the Delay Adjustment Screw (see Figure 4). Turn the screw counter clockwise until the light stays on. Turn the screw clockwise one complete revolution. This sets the delay to 1 second.
- B. To increase the delay, turn the Delay Adjustment Screw clockwise.

Watch the indicator light; quick flashes = shorter time delay, slow flashes = longer time delay.

Adjusting the Sensitivity

The Proximity Switch is shipped with the sensitivity preset at the factory. This setting is adequate for most feed types and conditions. However if the sensitivity does need to be adjusted, carefully follow these instructions:

- A. Allow power to be supplied to the switch for at least 15 minutes to properly warm the sensor. See the wiring diagrams in this manual.
- B. Set the Proximity Switch time delay to 1 second as specified above.
- C. Use a small screw driver to remove the caulk concealing the Sensitivity Adjustment Screw.
- D. Greater switch sensitivity is achieved by turning the Sensitivity Adjustment Screw clockwise.

Less switch sensitivity is achieved by turning the Sensitivity Adjustment Screw counterclockwise.

Note the screw orientation before beginning adjustment. Adjust the Sensitivity Adjustment Screw 1/4 turn, test switch, continue adjusting as required.

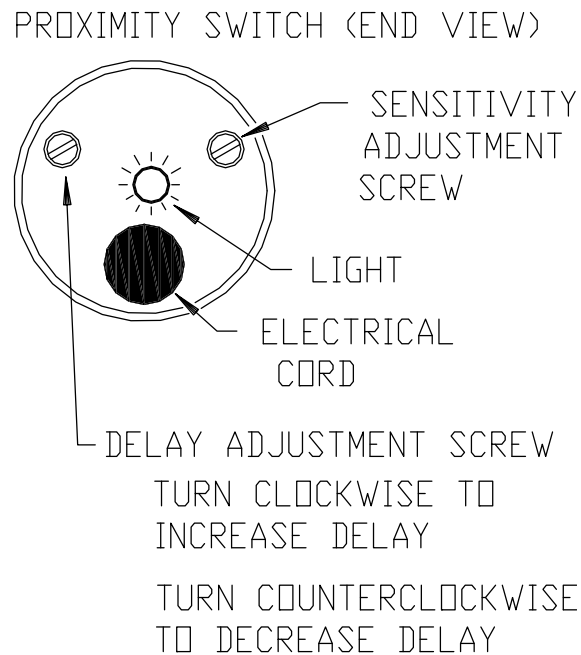

MA1044.2 3/94

Figure 4. Proximity Switch Adjustments (end view of Proximity Switch).

Proximity Intermediate Control Internal Wiring

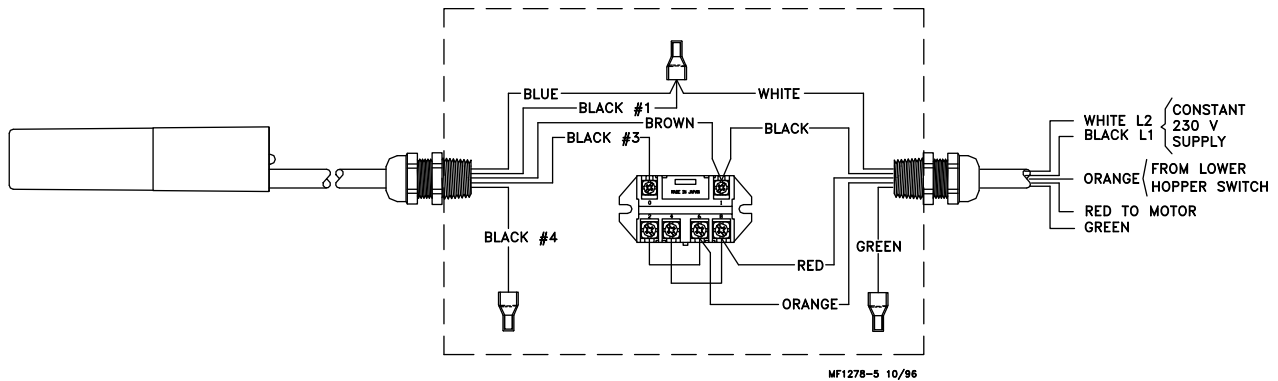

Proximity Switch Schematic

Important:

This wiring schematic represents the switch in the non-powered condition. When power is applied the N.O. and N.C. contacts reverse.

Refer to the wiring diagrams, above, when wiring the Proximity Switch.

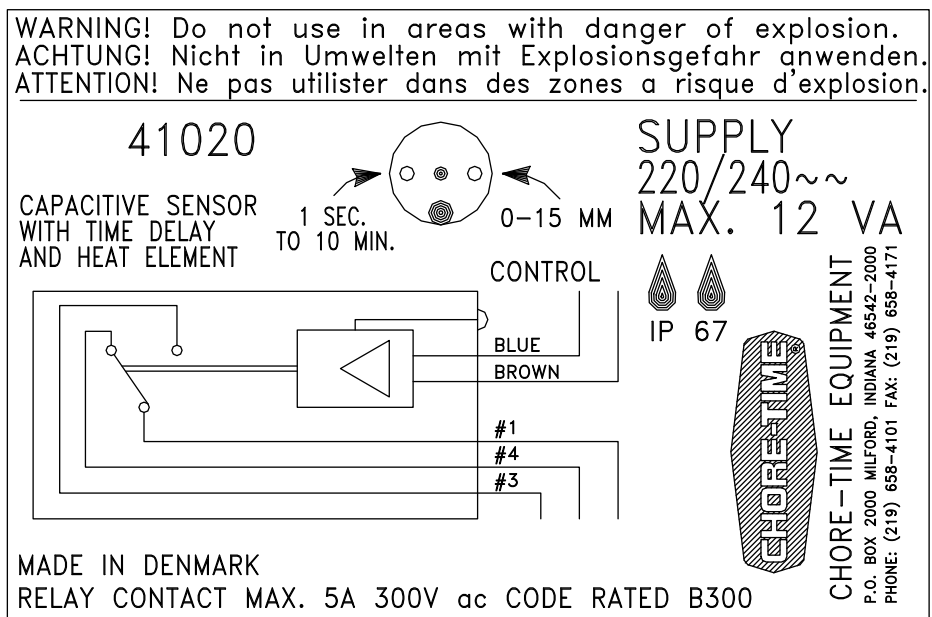

MF1278-6 1/96

System Overview for use with Wiring Diagrams

WIRING NOTES

Disconnect electrical power before inspecting or servicing the equipment, unless the maintenance instructions specifically state otherwise.

Wire the electrical equipment according to the wiring diagrams in this manual.

All field electrical wiring must be done by a qualified electrician, according to local and national codes.

Do not operate the equipment without the covers and guards properly positioned.

Failure to do so may cause personal injury or damage the equipment.

Ground all electrical equipment.

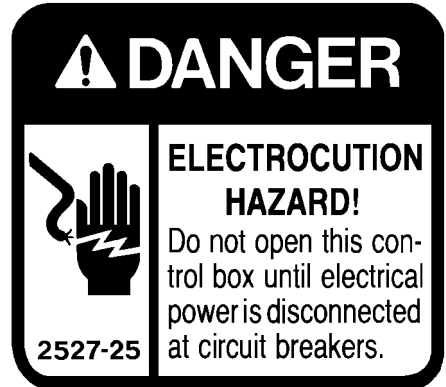

Note: Refer to this diagram as required to determine the location of Power Units, Switches, Control Units, etc. Each components is coded with a M1, S2, etc. (that's Motor #1, Switch #2).

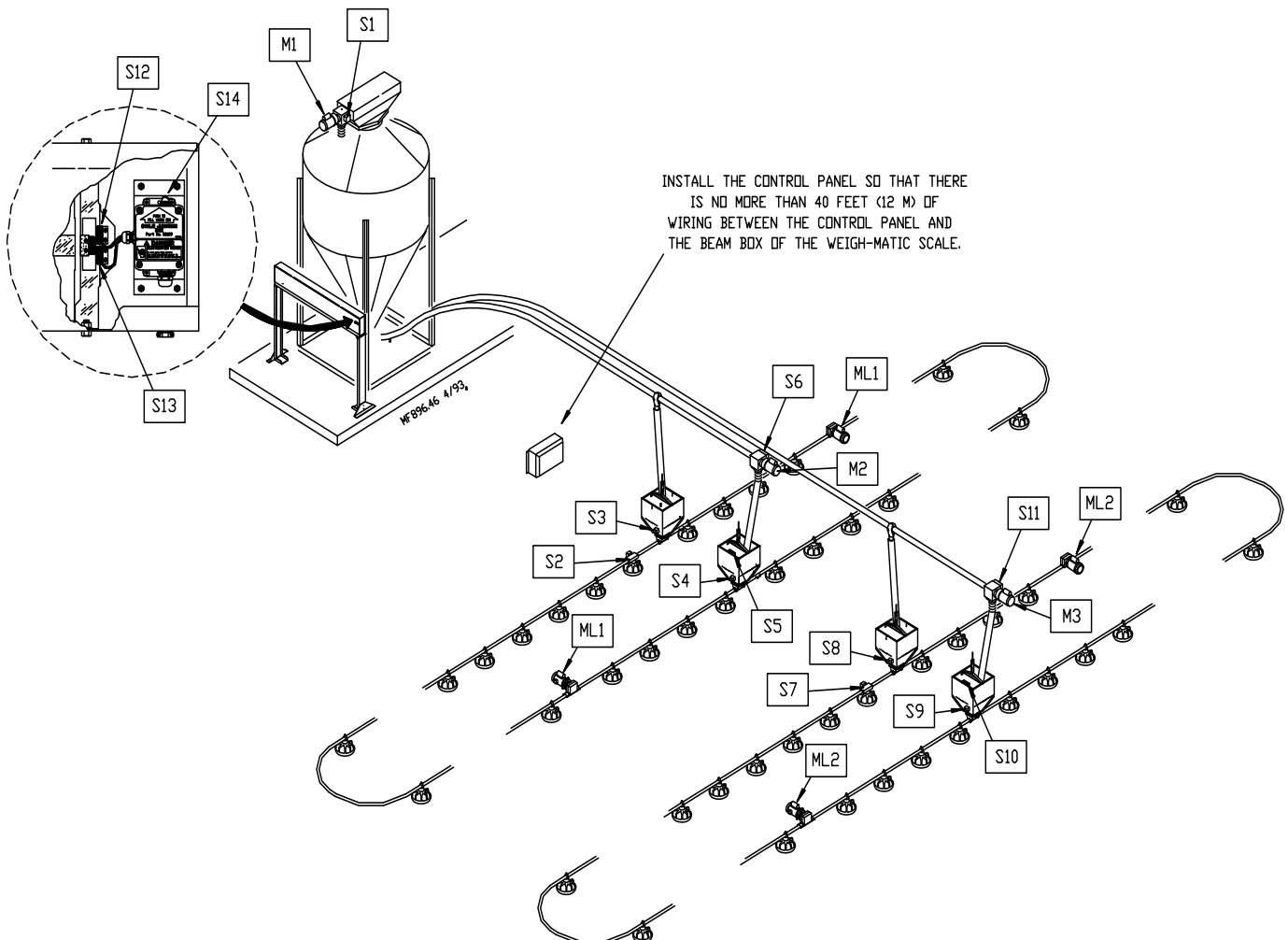

ULTRAPAN Feeder System Wiring Diagram (Using Chore-Time Mechanical WEIGH-MATIC Scales)

ELECTRICAL SPECIFICATIONS
 Voltage: 230 - Hz: 50/60 - Phase : Single

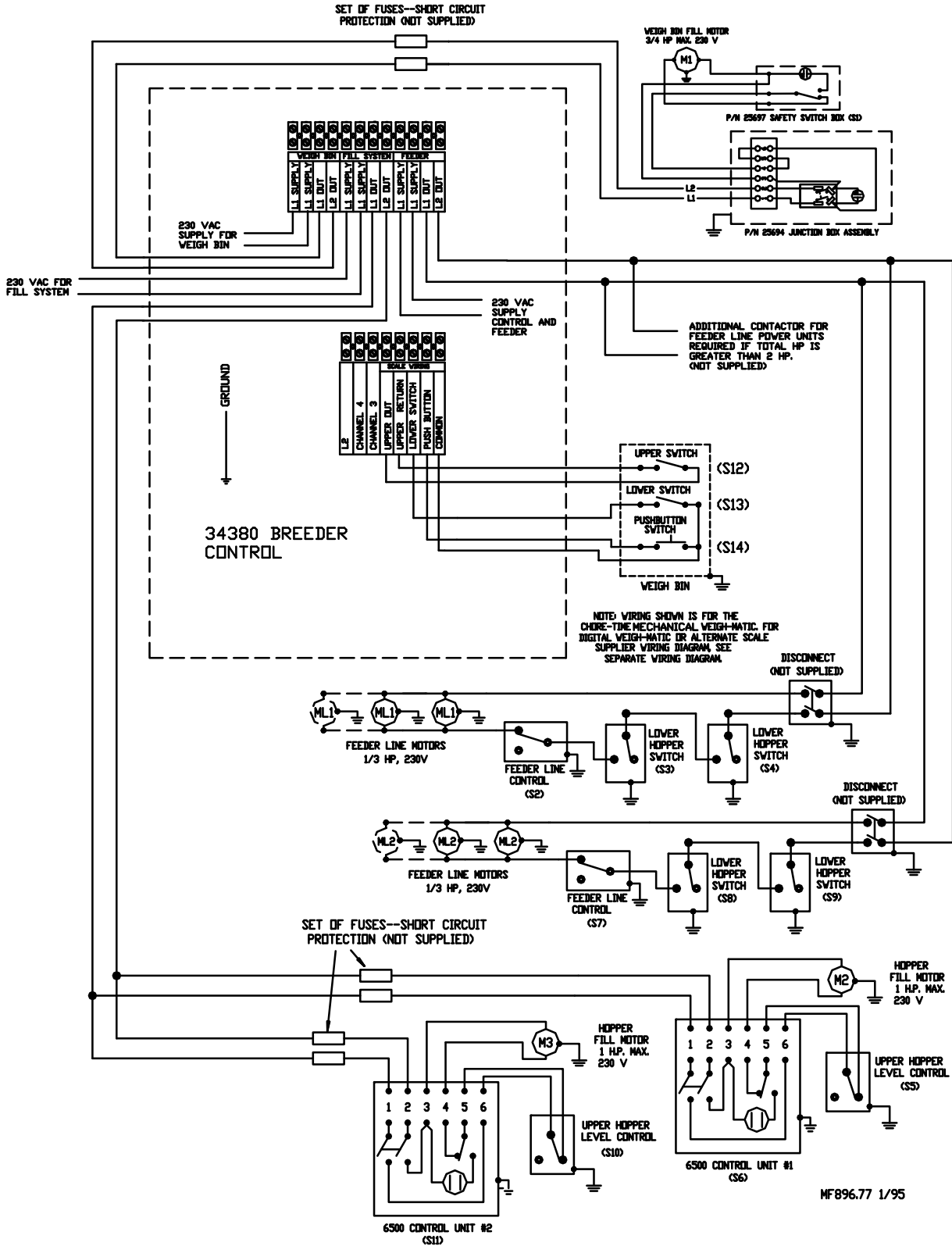

ULTRAPAN Feeder System Wiring Diagram

(Using Chore-Time Mechanical Weigh-Matic Scales)

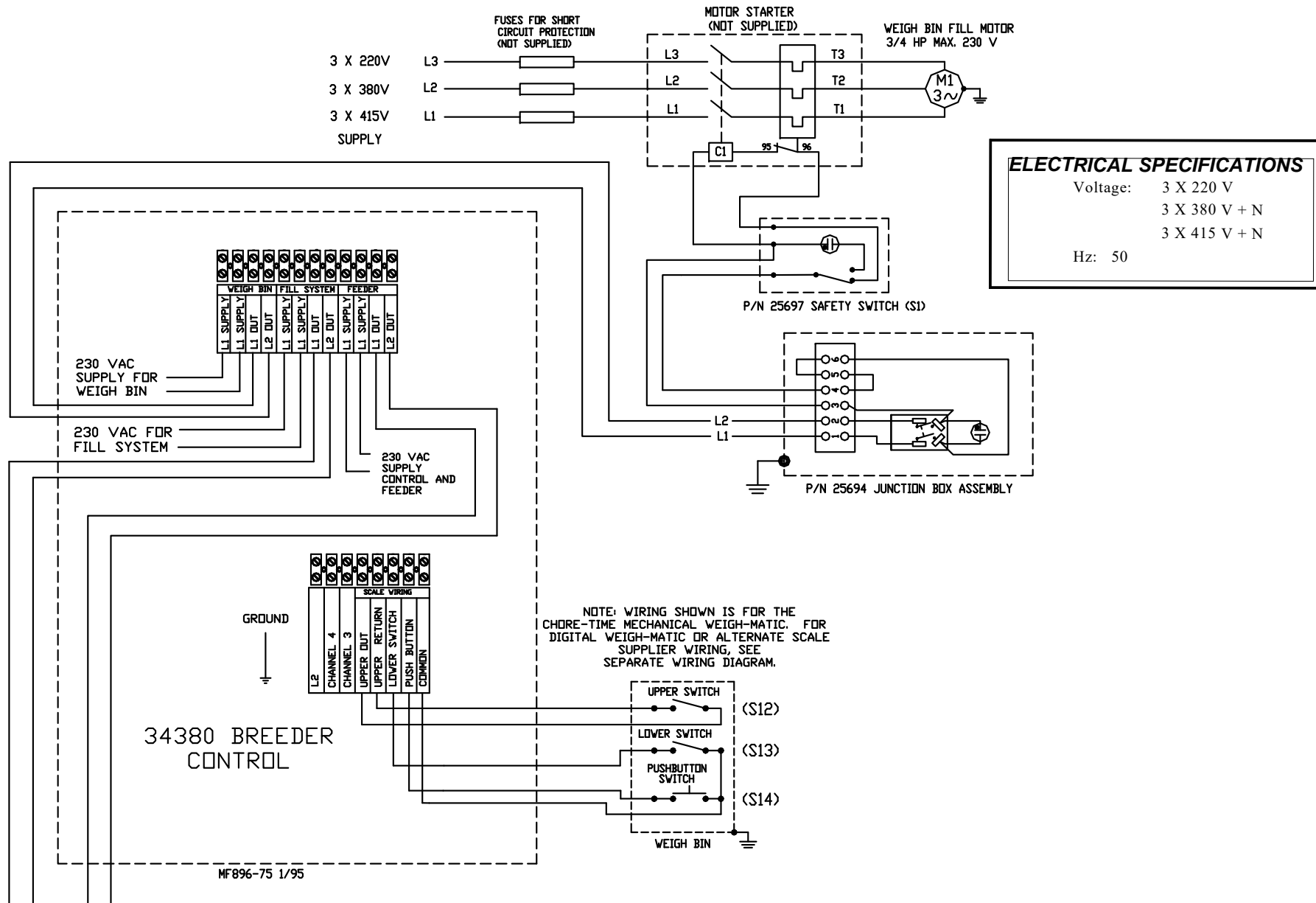

Continued on next page.

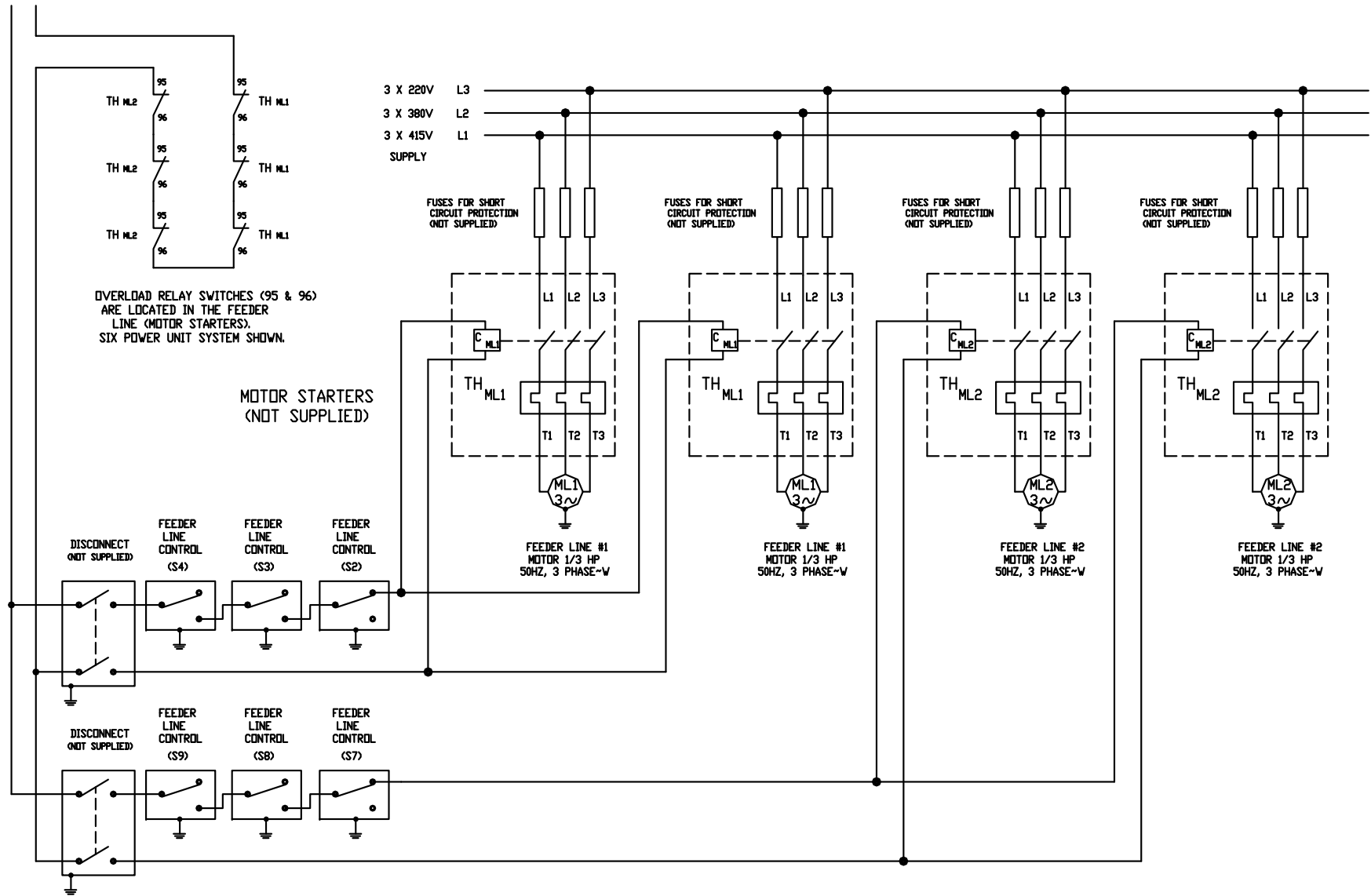

MF896-76 8/96

Continued from previous page.

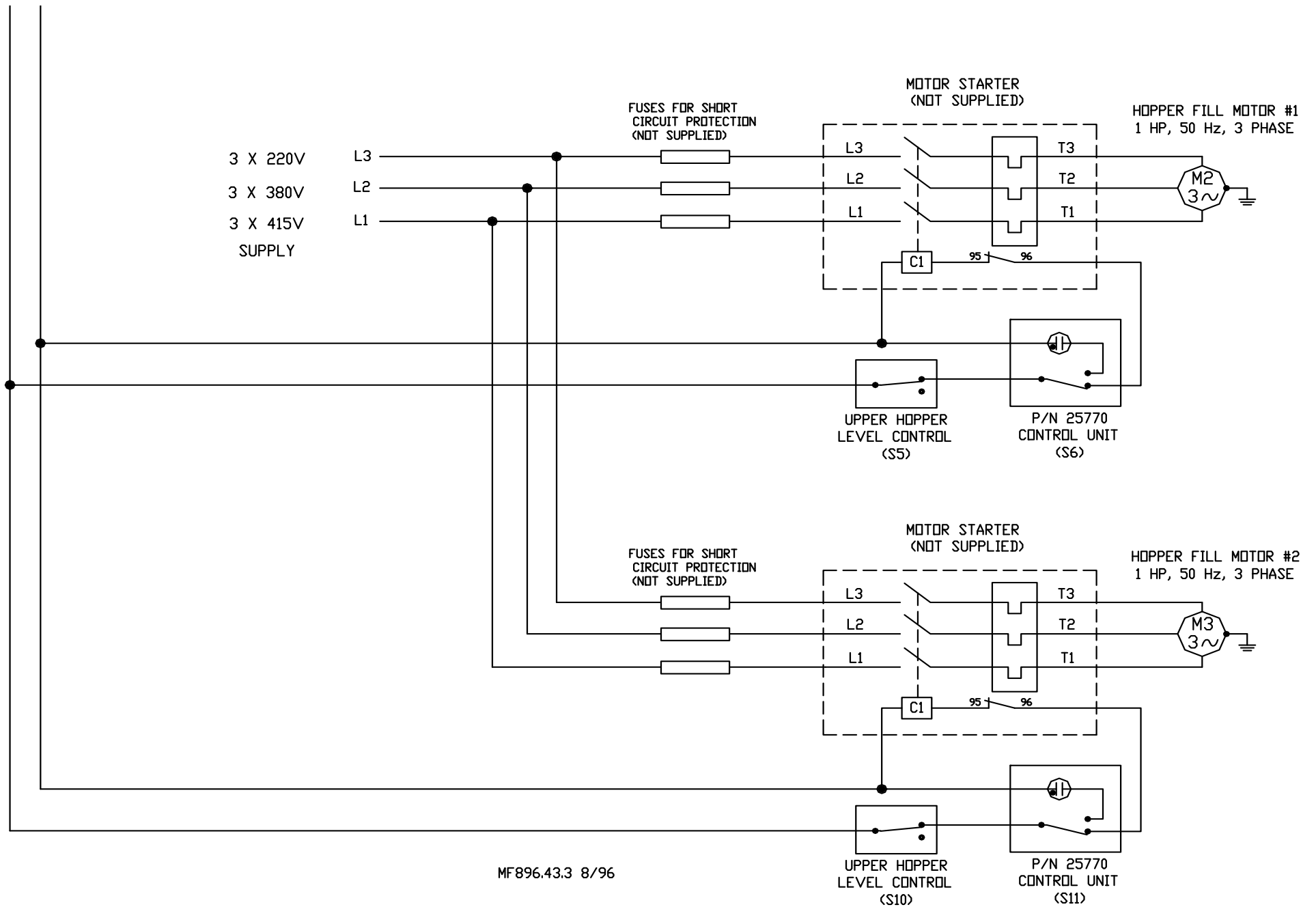

ULTRAPAN Feeder System Wiring Diagram

(For other brand scales without limit devise)

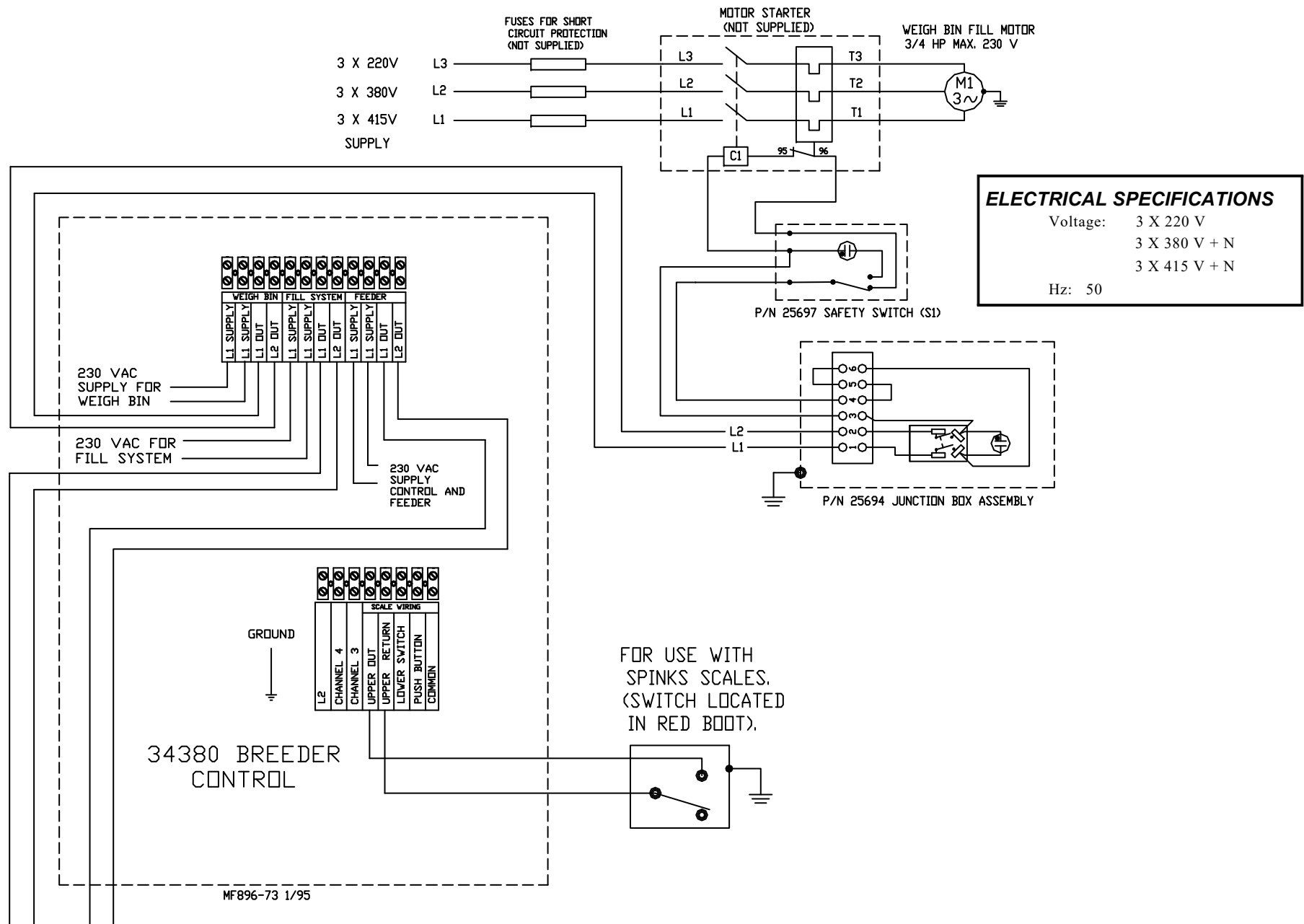

Continued on page 51.

Digital Weigh-Matic Scales / ULTRAPAN Feeder Control Wiring Diagram

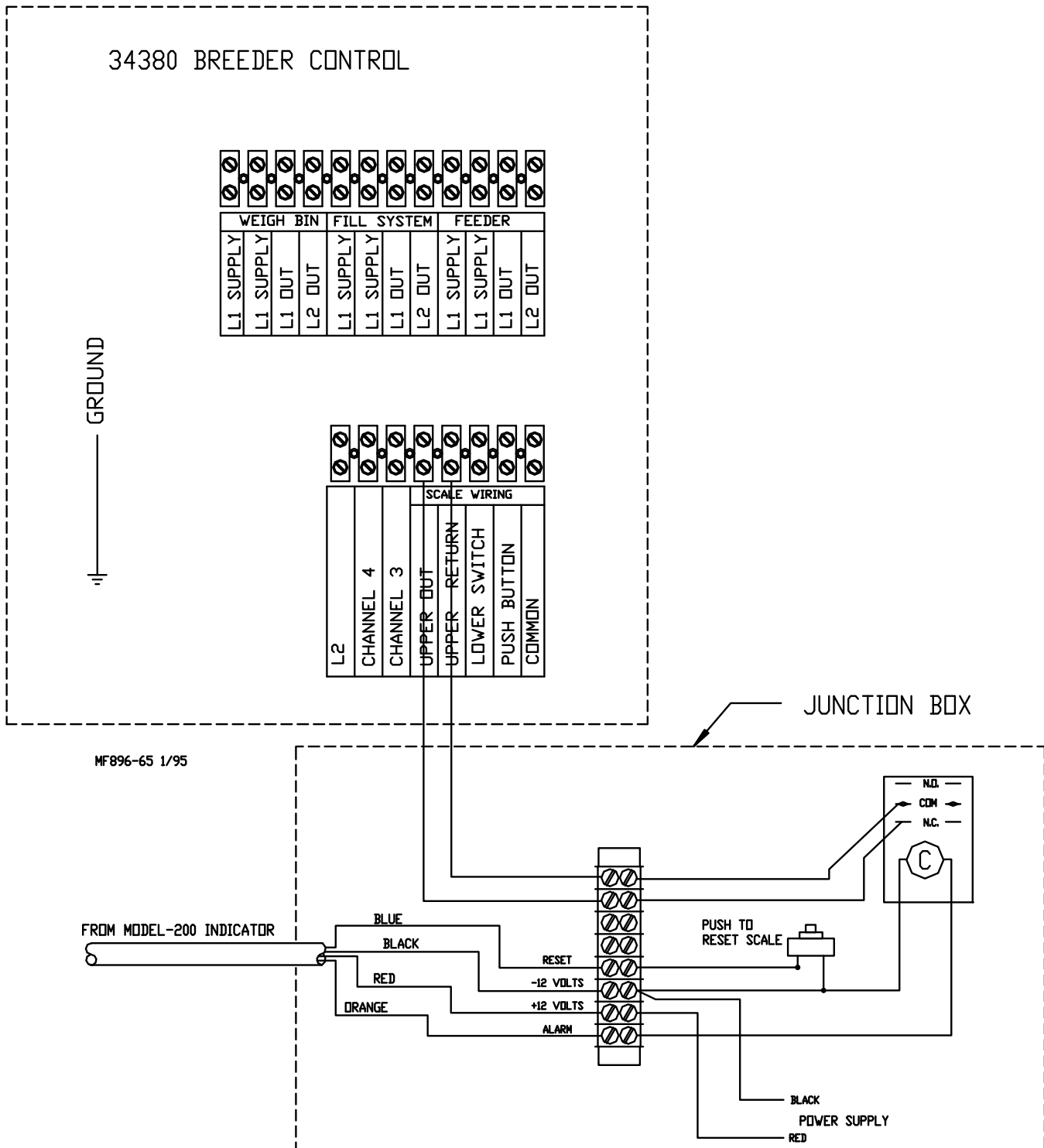

Operation of the Feeder

The ULTRAPAN Feeder is a circulating feeder, designed to supply all the feeder pans on the system simultaneously. The Auger Tubes are indexed to insure even distribution of the feed through out the system. The auger is driven by hardened sprockets on the power units spaced evenly around the system.

Channel 2 of the 34380 Breeder Control or the MANUAL FILL switch will fill the hoppers. Channel 1 of the Breeder Control operates the feeders. The feeders will operate until the control pan has been satisfied. The feeder lines are also controlled by the lower Hoppers Switch. This switch assures that the lines retain their charge. The fill system is controlled by the weigh bin. When the bin reaches "0" the system will stop filling the hoppers.

34380 Breeder Control

The 34380 Breeder Control must be mounted inside the house in a convenient location, out of reach of the birds.

The Breeder Control is used with the WEIGH-MATIC Scale and Fill System and the ULTRAPAN Feeding System to accurately weigh and deliver a preset amount of feed per day for breeder birds.

The control utilizes an Agri-Timer time board with a permanent battery backup that keeps the clock on time in the event of a power outage. Even your existing program is stored in *hard memory*. The battery is accessible and may be replaced if necessary. Refer to the maintenance section on page 76.

Refer to Instruction MF1061 (shipped with the Control) for programming information and operation of the Control.

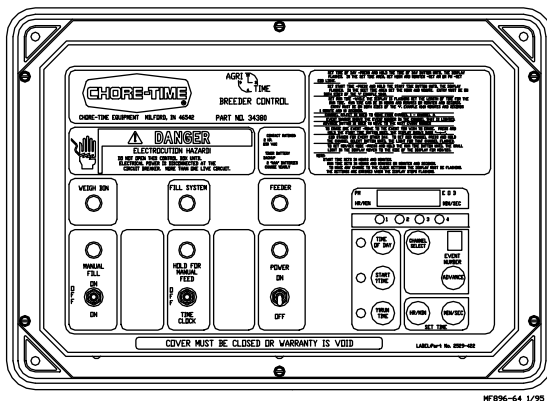

ELECTRICAL SPECIFICATIONS for the 34380 Control Panel

—Contactor Outputs—
230 VAC / 25 amps, 2 HP each

—Fuses—
3 amp maximum (each)

Balancing the Mechanical Scales

All fill system wiring **MUST BE COMPLETED** before attempting to balance the scale.

Never balance the scales if any of the delivery or fill augers are empty. The Weigh Bin should have approximately 50 pounds (22.6 kg) of feed in it whenever the scales are balanced.

1. Turn switch "ON" at the Breeder Control.
2. Hold weight beam down and momentarily press switch button in beam box. This starts the fill system and it will bring feed into the weigh bin. Run delivery system long enough to bring 200 to 300 pounds (90.7 to 136 kg) of feed into the bin. Delivery capacity of the Model 90 Auger is approximately 100 pounds (45 kg) per minute. Run the fill system the appropriate length of time to achieve 200 to 300 pounds (90.7 to 136 kg) of feed in the weigh bin.
3. Release the Weighbeam and allow it to raise up, away from the lower proximity sensor. The fill system will stop.

4. Program the Feeder Control Panel, according to the MF1061 Instruction, to allow the incoming fill system to start (when the Weighbeam moves to the upper proximity sensor) or use manual fill option.
5. Raise the Weighbeam so that it moves to the upper proximity sensor. The delivery system that carries feed from the weigh bin to the building will start.
6. Run all but about 50 pounds (22.6 kg) of feed from the weigh bin. Some feed **MUST** remain in the boot. **THIS WILL BE THE ZERO POINT FOR BALANCING THE SCALE.**
7. Turn switch "OFF" at the control before making balancing adjustments.
8. Move poise on Weighbeam to "0" against the stop pin.
9. Slide back Balance Assembly along the Weighbeam until the end of the Weighbeam is centered midway between the two sensors. Lock the back Balance Assembly to the Weighbeam.
 - If finer adjustment is required, adjust the brass rod on the Back Balance until the Weighbeam is centered between the two sensors.
10. Check the accuracy and balance by setting the system for a small quantity of feed (20 pounds or 9 kg, for example). Cycle the fill system and make the following checks:
 - Check Weighbeam so that it does not over-travel or float when moving from an unbalanced position to the balance point.
 - Check the quantity of feed delivered by cycling and collecting feed from the weigh bin. Number of pounds or kilograms delivered should be the amount at which the scale was set.

Operation of the Scale

1. Make sure the time clock on the Breeder Control Panel is set to the present time.
2. Program the starting time and length of the feeding period for the Feeder(channel #1). For the Fill System, set for the same start time and the length of time for 3 minutes(channel #2)
3. Set the poise on the Weighbeam for the desired quantity of feed.
4. Momentarily press switch button on the beam box until the FLEX-AUGER system bringing feed into the weigh bin starts. The FLEX-AUGER system will transfer the desired quantity of feed into the weigh bin; then it will shut off automatically.
5. Set poise to zero **AFTER THE WEIGHBEAM REACHES THE BALANCE POINT AND THE FLEX-AUGER SYSTEM STOPS.**
6. The feeder is controlled by channel #1 on the Breeder Control. It will start running when the time clock signals that feeding period should begin. They will continue to run as long as feed is available or to the end of the programmed feeding time.

NOTE: Adequate time should be programmed for the feeder so that all of the measured feed is consumed during each feeding period. Monitor the feed consumption. If the measured amount of feed has not been dispensed from the weigh bin and/or the feed in the feeder line hoppers has not fed down to where the lower hopper switches cut the line off, then increase the length of feeding time.

Lower Hopper Switches will shut off individual lines as they become empty as the measured amount of feed is dispensed.

The fill system is controlled by channel #2 of the Breeder Control. A short period of run time is all that is required to activate the weigh system. The weigh system locks in the Fill System until the desired feed ration is depleted

7. The operator must manually set the scales to the amount required for next feeding and push the momentary switch to start filling the weigh bin for the next feeding.

Refer to "Operation of the Scales" and "Optional Fill System Operation" for further details on running the scales/ fill system.

Start-Up Procedure

Follow this procedure with new and refilled houses.

NOTE: The following procedure is to be run on each loop individually. Therefore, disconnect power at each power unit on the loop not being started. Also, flip the appropriate Control Unit Toggle Switch to the OFF position.

1. Set the POWER switch to the ON position.

Push and hold the MANUAL FEED switch for manual operation. Allow the feeder to run long enough to clean all the foreign materials (i.e. sawdust, dirt) out of the auger tubes.

Release the switch to stop the feeder.

Repeat the above for the other feeder loop(s).

2. Move feed into the weigh bin.

Open the weigh bin slide approximately 3 inches (75 mm).

3. Start the system by setting the POWER switch to the ON position.

Push the "MANUAL FILL" button on the Breeder Control, to start the fill system.

NOTE: Run the Fill System manually to allow approximately 50lb.[23kg] of feed increments into the hopper. Stop the Fill System periodically. This will allow the feed to be removed from the hopper and prevent over charging the feeder loop

Use the Control Unit Toggle Switch to turn the fill system on and off, as required, to prevent overloading the "unpolished" augers with feed.

4. Turn off electrical power to the system.

6. Repeat the start-up procedure, above, on the second feeder loop.

ULTRAPAN Management Guidelines

The ULTRAPAN Feeding System is designed for controlled distribution of feed to broiler breeder pullets and layers. The system utilizes indexed tubes for a uniform, constant, and fast feed delivery immediately to all the feed pans. The Model C2 PLUS® Breeder Series Feed Pan Assembly is designed to provide optimum feed flow and to maintain a low level of feed to deter feed wastage. The C2 PLUS features a feed volume reduction tube and a feed cone with feed fins to provide improved feed conversions when compared to other types of feeding systems. (Optional)The Model C2 PLUS Feed Pan Assembly is available with feed flood windows which allows the feed pan, when lowered to the floor, to be filled with a high level of feed for the brooding of day old through 12 day of age birds.

There is no substitute for good management of a poultry house. The following information and recommendations are to be used a guideline for the operation of the ULTRAPAN Feeding System with C2 PLUS Feeder Pans. As you become familiar with the system, this guideline will need to be modified to allow for individual poultry types, building types, and various climate conditions.

Brooding

Model C2 PLUS® with Windows

For brooding birds, the feeding system is lowered to the floor which allows the feed windows of the C2 PLUS Feed Pans to open. When the feed windows are open, the feeding system should be operated MANUALLY ONLY, a minimum of 2 times per day, from 1-5 days of age, and 3 to 4 times per day, from 6-12 days of bird age.

Although the C2 PLUS feeder is designed to brood birds, the most widely used method, is to provide feed trays (chick trays, feeder lids), usually one per 100 chicks, as an additional feed access area. These are filled manually. The number of feed trays are reduced beginning at approximately 5 days, and should be completely removed by 6 days, or as soon as the chicks have adjusted to eating from the C2 PLUS feeding system.

During the brooding time, or when the feed windows are open on the C2 PLUS feeder pans, make sure the feed pans always have an adequate amount of feed in them by activating the control pan. To accomplish this, you may have to remove the control pan and catch the feed between it and the last pan, empty the feed, and replace the control feed pan. This action, if needed, will help assure the feeding system has the proper amount of feed for the birds, and will attract the birds to the feeder.

At approximately 7-16 days, the feeder line should be raised to close the feed windows so the pans, just clear the floor. At this period of time, the feed level will become low. The birds will learn to work the feed into the feed pans in a very short time. During this transition period, make sure the birds are activating the control pan to refill the system. The recommended feed level setting is #4. The feed level setting can be increased or decreased if necessary for some types of feed stuffs.

Model C2 PLUS Non-Window

For brooding use the non-windows C2 Plus feeder, lower the pans until they just touch the floor. Provide supplemental chick feeder tray at a rate of 1 per 100 chicks. Manually fill the chick trays and the C2 PLUS feeder pans with a high level of feed for starting the chicks. Maintain a high level for the birds for 5 days, there after reducing it through 16 days. The feeder can be operated manually by removing the control pan.

Grow-Out

The feeder line should be raised weekly as the birds grow so the lip of the feed pan is level with the area where the birds neck meets the breast.

At 21 days, or when the restricted feeding program is initiated, set sufficient run time on the Breeder Control for the feeding system to dispense the entire feed ration.

This manual provides additional information regarding operation of the scale.

Chore-Time recommends you consult your poultry representative for additional information concerning bird types, climate conditions, building types, and management practices.

PARTS LIST

Hopper Components

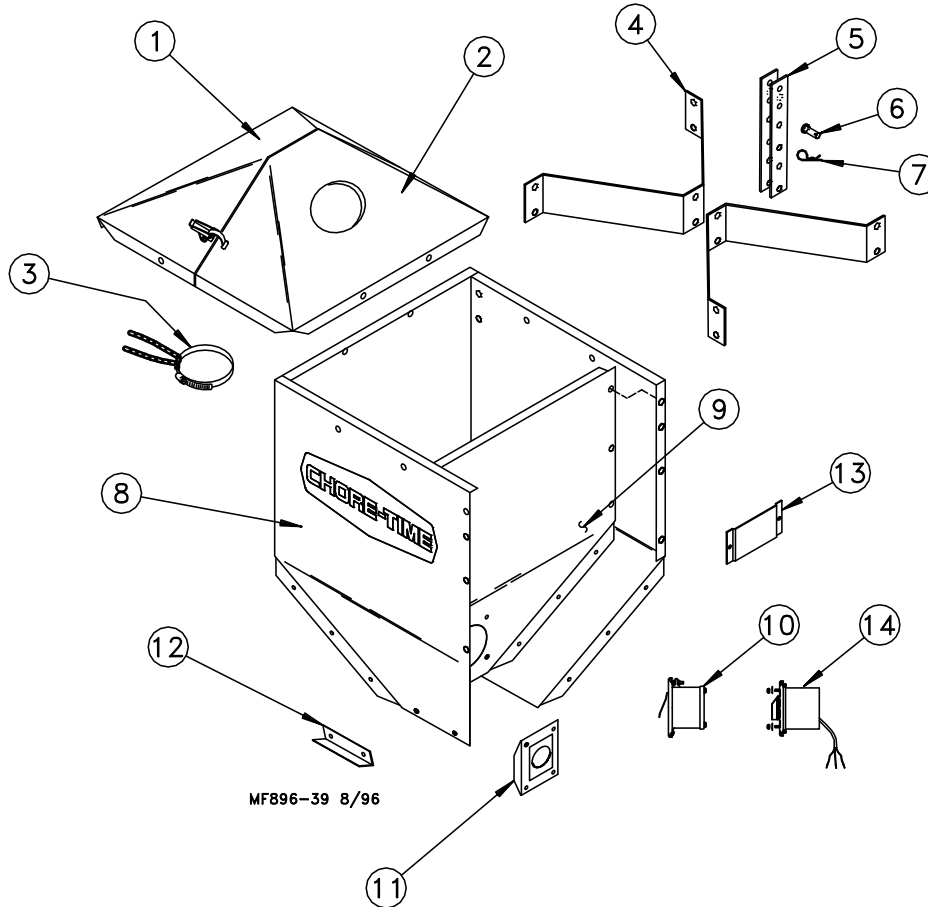

<u>Item</u>	<u>Description</u>	<u>Part No.</u>
1*	Hopper Cover (w/o hole)	28212
2*	Hopper Cover (w/ hole)	28211
3	Tube Support Kit	14367
4	Hopper Hanger	28165
5	Adjustment Bracket	2706
6	Clevis Pin	2797-1
7	Hair Pin	2664
8	Hopper Side (w/o hole)	28164
9	Hopper Side (w/ hole)	28241
10**	Lower Hopper Switch	8798
11	Diaphragm Assembly	7900
12	Boot Hanger	28168
13	Support Plate	28267
14	Lower Hopper Switch(optional)	46910
--	Parts Package (contains necessary hdwr)	28167
--	Over Center Clamps	2536

NOTES:

*These components may be ordered as an assembly under Part No. 28210.

**See page 50 for individual components.

The 100# Hopper Assembly, including the Switch only, may be ordered under Part No. 28242.

The 100# Hopper Assembly, including the Hopper Cover and Switch, may be ordered under Part No. 28245.

8798 Lower Hopper Switch Assembly

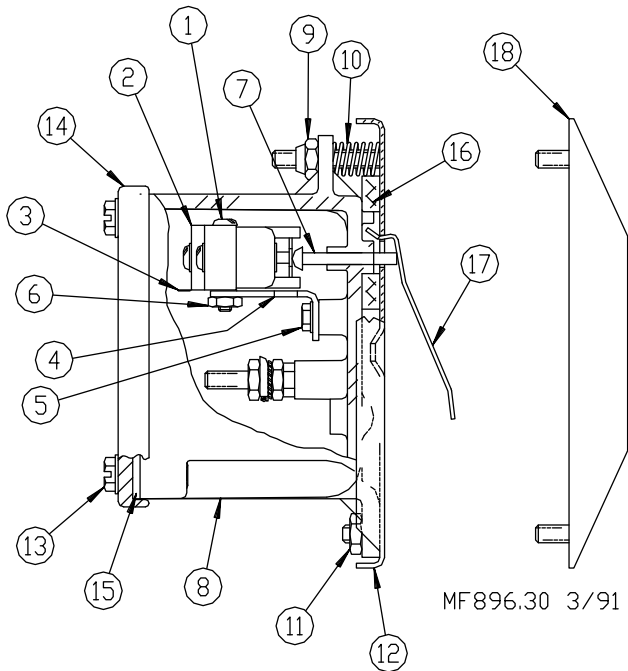

<u>Item</u>	<u>Description</u>	<u>Part No.</u>
1	6-32 x 7/8" Rd. Hd. M.S.	1921
2	SPDT Actuator Switch	7114
3	Switch Insulation	1907-5
4	Switch Bracket	7068
5	#6 x 3/8" Slot Wash. Hd. Screw	6782
6	6-32 Hex Nut	771
7	Pin	8757
8	Switch Box	7841
9	10-32 Hex Lock Nut	6963
10	Spring	6972
11	10-32 Hex Nut	4297
12	Mounting Plate	7908
13	#10 Twin Helix Screw	6980
14	Switch Box Cover	6776
15	Gasket	6777
16	Gasket	6968-1
17	Paddle	7896
18	Diaphragm Assembly	7900
--	Deflector	28281

MF896.30 3/91

34824 Boot Assembly

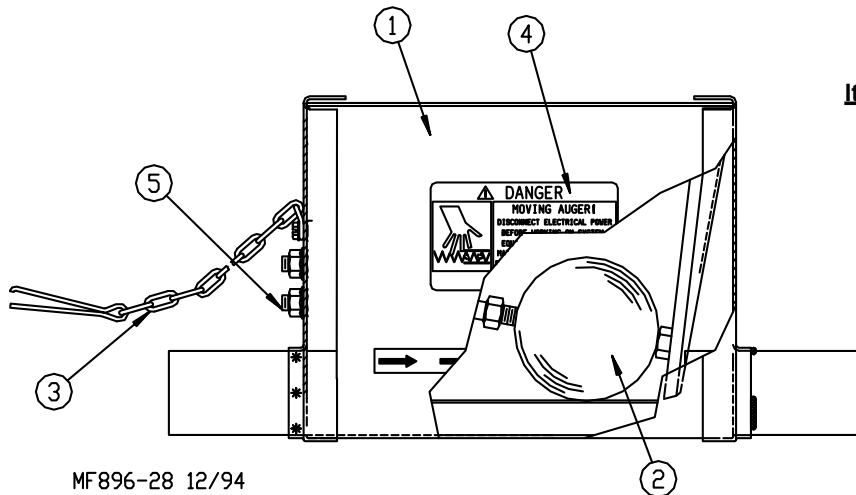

<u>Item</u>	<u>Description</u>	<u>Part No.</u>
1	Boot Weldment	34811
2	Agitator Assembly	34804
	Agitator Ball	34803
3	Latchpin Assembly	2683
4	Danger Decal	2527-9
5	5/16" U-Bolt	34823

MF896-28 12/94

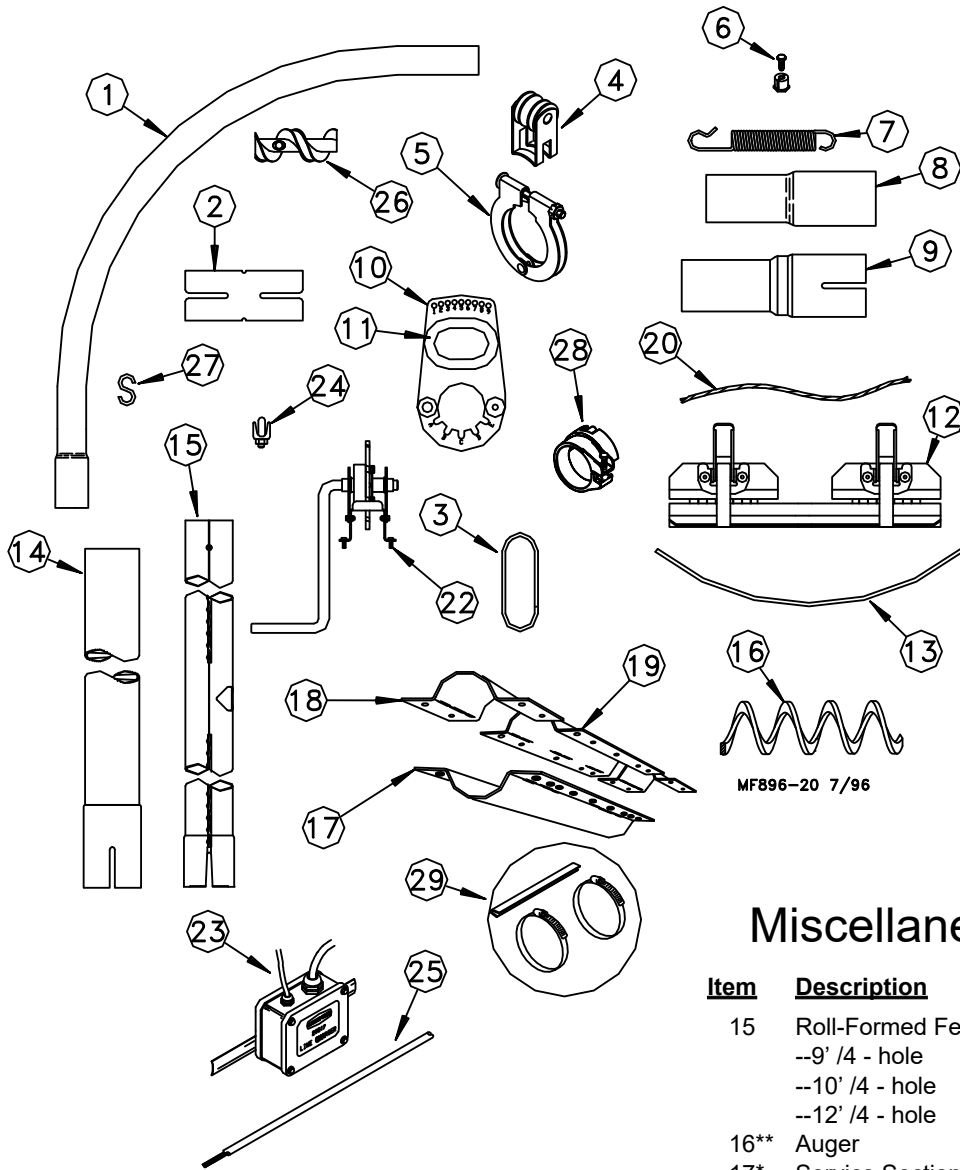

MF896-20 7/96

Miscellaneous Components

<u>Item</u>	<u>Description</u>	<u>Part No.</u>
1	90 Degree elbow	28125
2	Tube Coupling (1-3/4" diameter)	2123
	Tube Coupling (2" diameter)	29691
3	Hanger	4207
4	Insulator Bracket	24060
5	Tube Clamp	24063
	2" Tube Clamp	29520
6	3/32" Cable Clamp	1826
7	Spring	7551
8	Tube Adaptor	28107
9	Belled Adaptor Tube	29693
10+	Adjustable Hanger	14780
11+	Grommet	14899
12	Welding Fixture	25494
13	Anti-Roost Wire	28108
14	4' Extension Tube	28128

<u>Item</u>	<u>Description</u>	<u>Part No.</u>
15	Roll-Formed Feeder Tube	
	--9' /4 - hole	6854-1
	--10' /4 - hole	6854-4
	--12' /4 - hole	6854-7
16**	Auger	28103-0
17*	Service Section Base	28153
18*	Service Section Clamp	28151
19*	Service Section Cover	28152
20	1/16 Cable	1922
22	Auger Driver	28126
23	Line Charger	29317
24	1/8" Cable Clamp	14898
25	Hi-Voltage Cable (330')	28994-330
	Hi-Voltage Cable (500')	28994-500
	Hi-Voltage Cable (165')	28994-165
26	Auger Connector	29055-2
27	S Hook	723
28	Anti-Swing Lock - Pullets	34570
29	Anti-Swing Lock - Breeders	14485

+ These components may be ordered as an assembly under Chore-Time P/N 7604.

* These components may be ordered as an assembly under Chore-Time P/N 28127.

**The Auger may be ordered in lengths from 100' to 330'. Include the specific length as a suffix to the part number (example: 28103-220 is a 220' roll of auger).

Standard Breeder Pans

**DEEP BREEDER PAN
W/WINDOWS, & REDUCTION
TUBE**

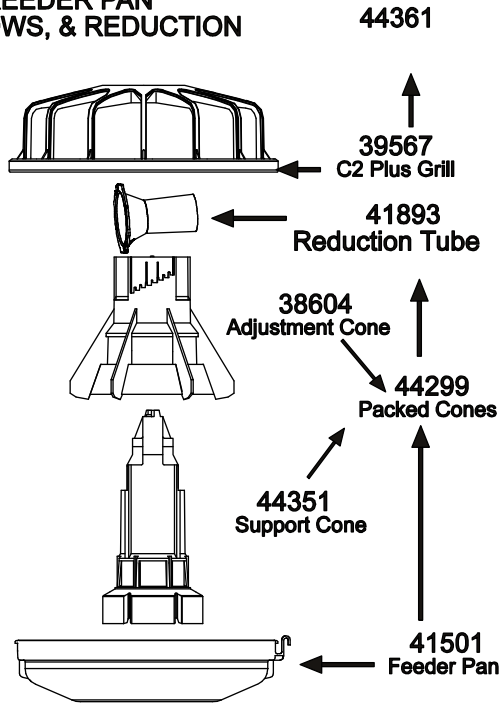

**DEEP BREEDER PAN
NON-WINDOW, & REDUCTION
TUBE**

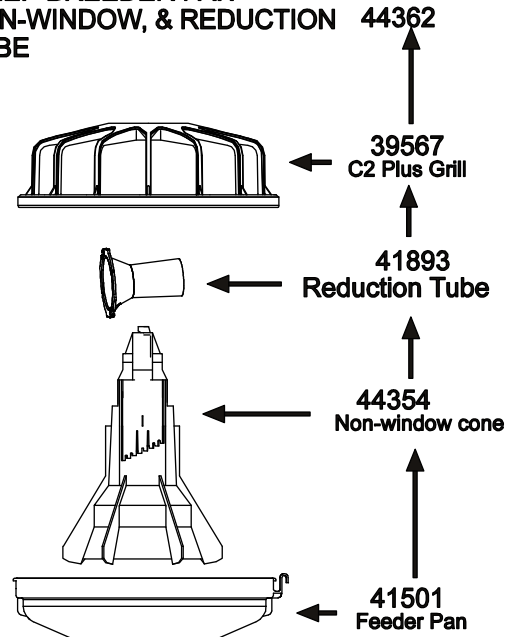

**DEEP BREEDER PAN
W/WINDOWS, REDUCTION TUBE, &
REM. TOP**

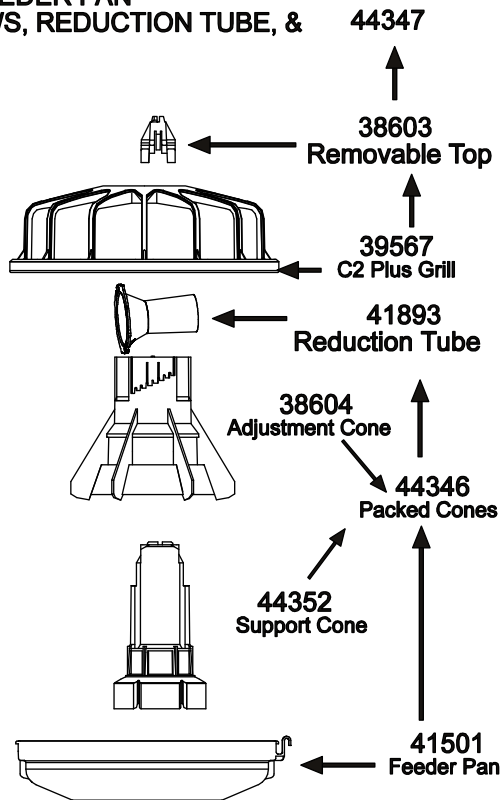

**DEEP BREEDER PAN
NON-WINDOW, REDUCTION
TUBE & REM. TOP**

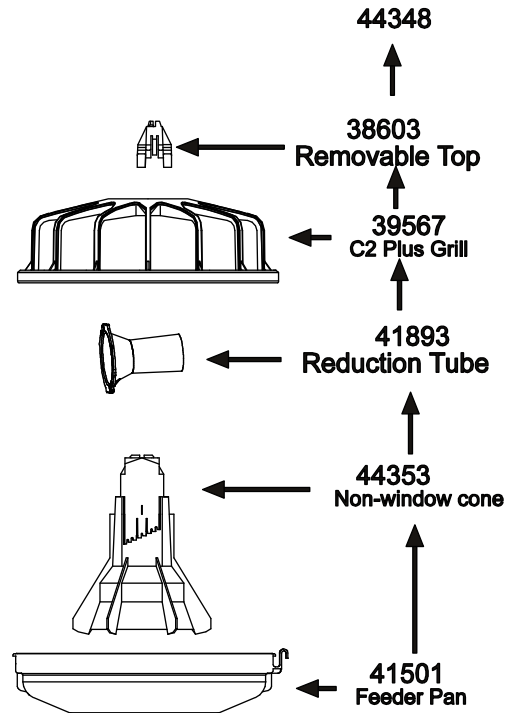

896-95

Standard Breeder Pans WITH SHUT-OFF

**DEEP BREEDER PAN
W/WINDOWS, W/SHUT-OFF
&REDUCTION TUBE**

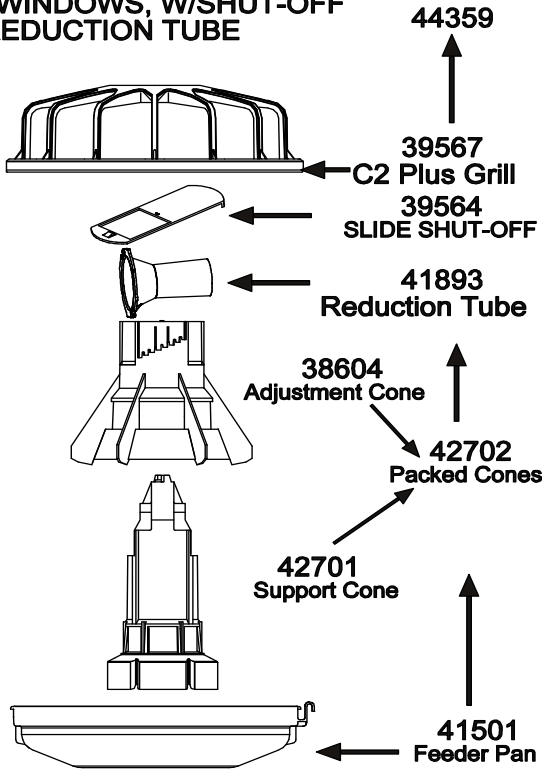

**DEEP BREEDER PAN
NON-WINDOW, W/SHUT-OFF
& REDUCTION TUBE**

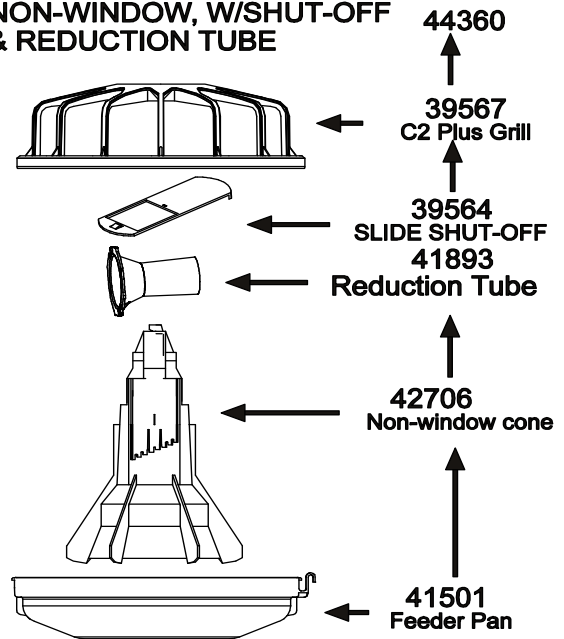

**DEEP BREEDER PAN
W/WINDOWS, W/SHUT-OFF,
REDUCTION TUBE & REM. TOP**

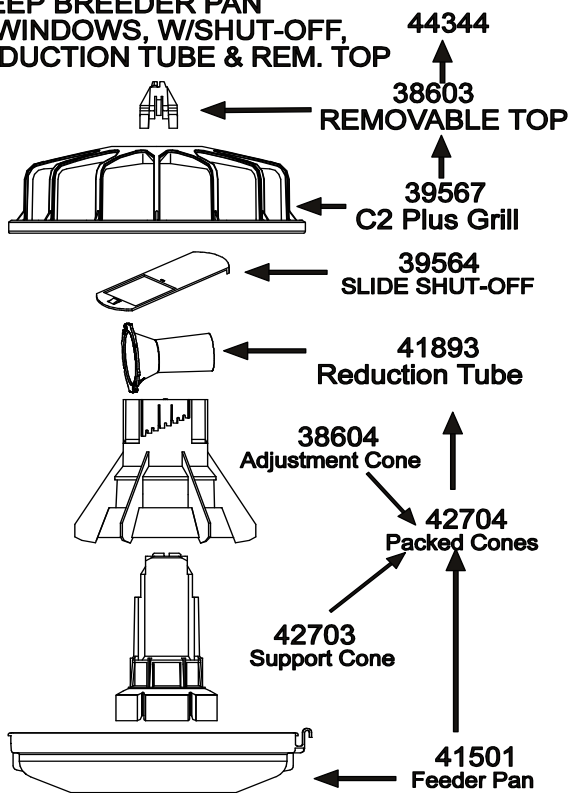

**DEEP BREEDER PAN
NON-WINDOW, W/SHUT-OFF,
REDUCTION TUBE & REM. TOP**

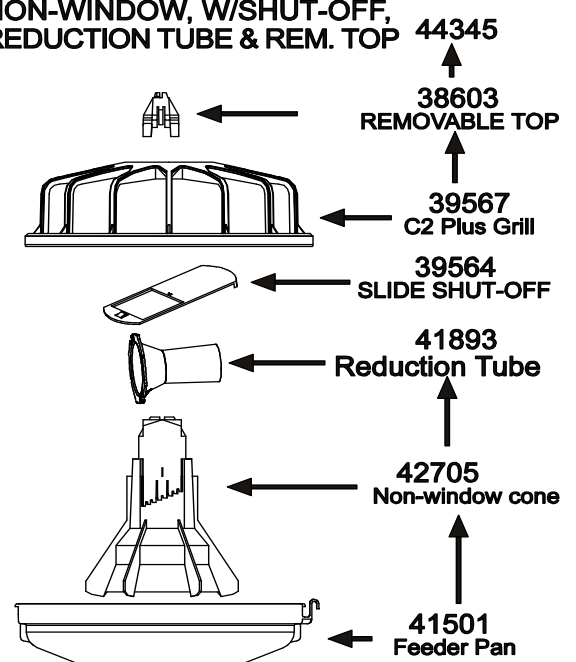

896-94

Shallow Breeder Pans

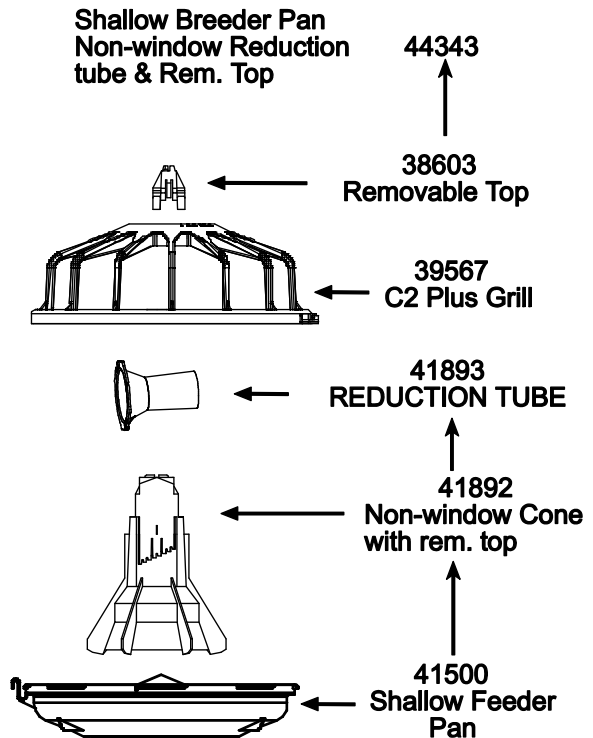
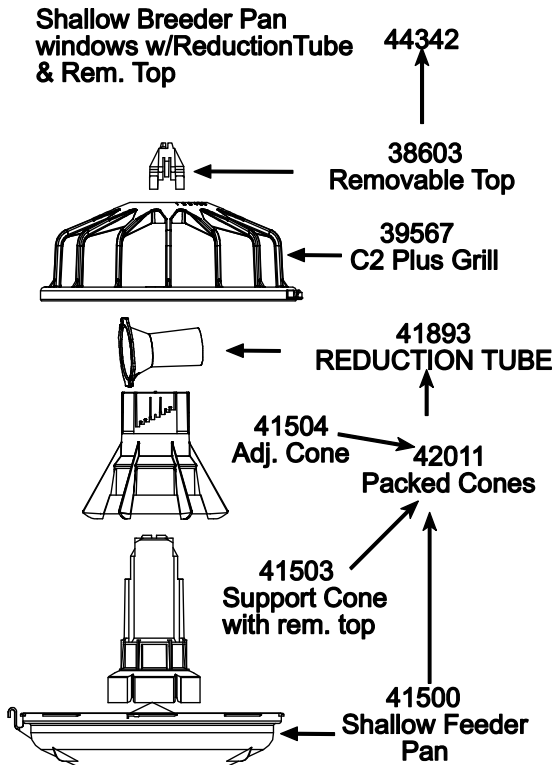
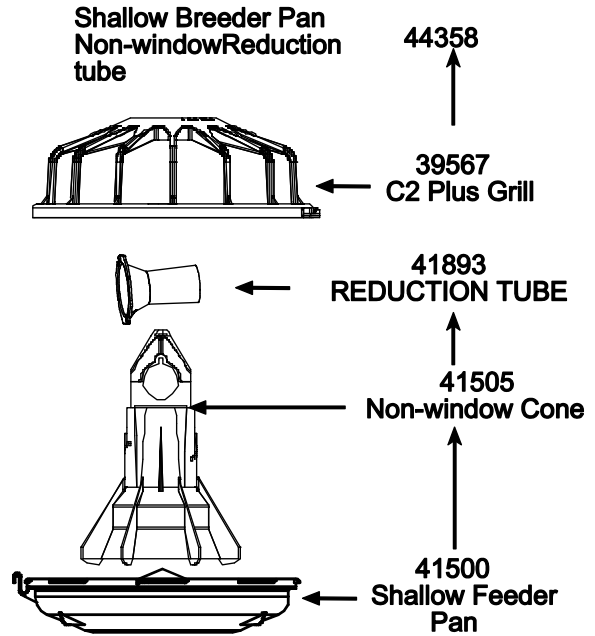
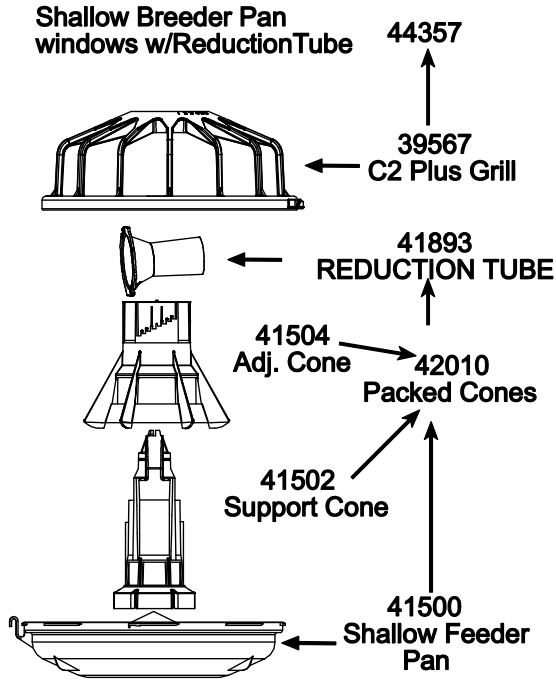

896-97

Shallow Breeder Pans

with Slide Shut-off

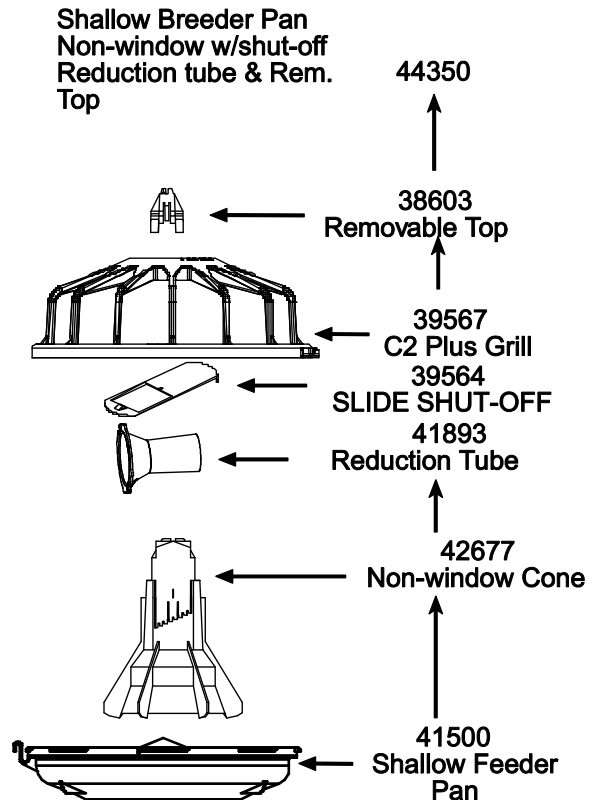
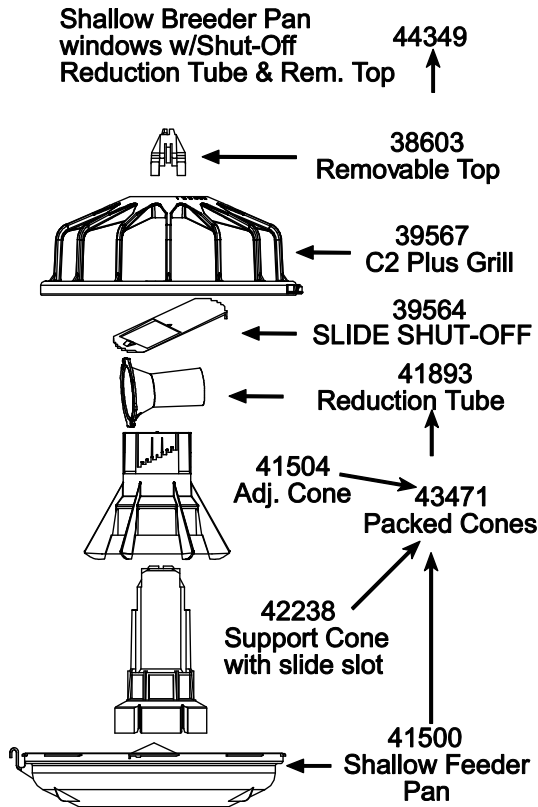
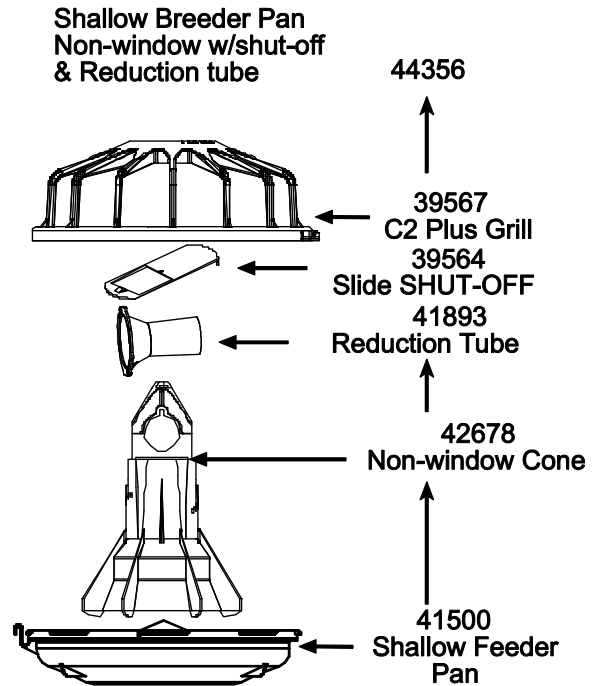
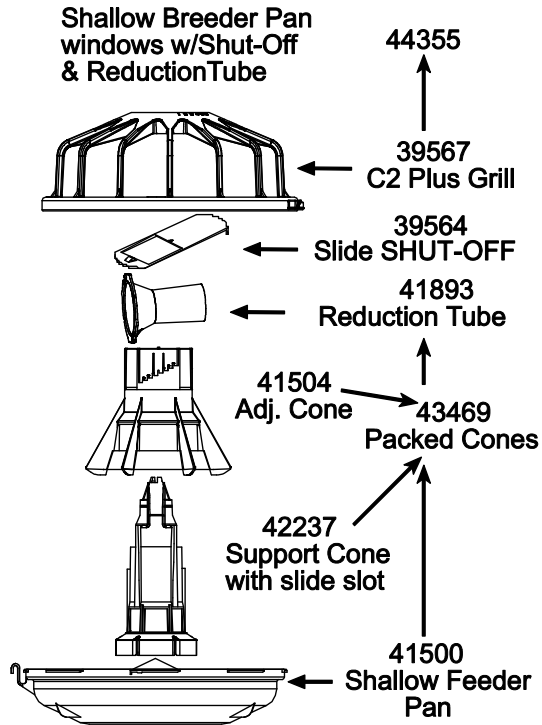

Model C2 PLUS Intermediate Control (Standard & Shallow)

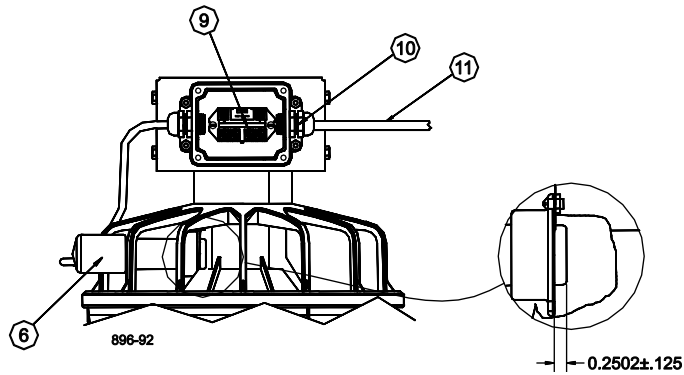
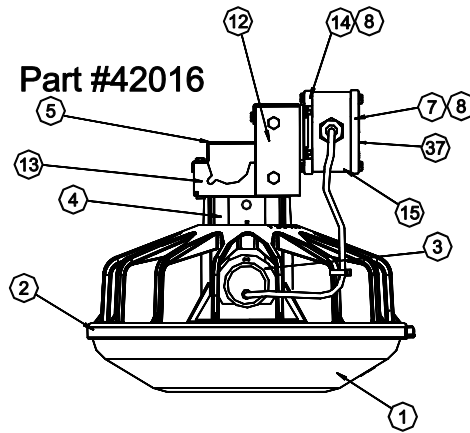
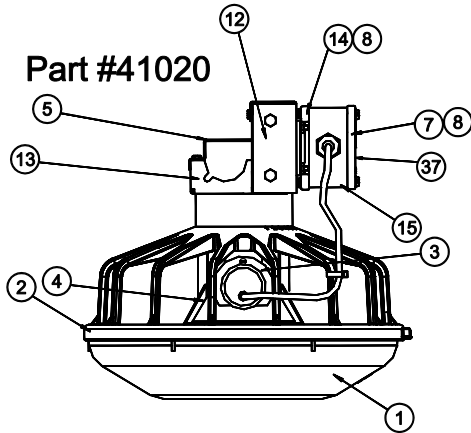

Item	Description	P/N 41020	P/N 42016
		Standard Part No.	Shallow Part No.
1	Model C2 PLUS Feeder Pan	38600	41500
2	Feeder Grill	39567	36567
3	Prox. Mount. Collar	36966	36966
4	Support Cone Assembly	40957	42417
5	Tube Retainer	14756	14756
6	Proximity Switch Ass'y	36868-1	36868-1
7	Switch Box Cover	6776	6776
8	Gasket	6777	6777
9	Relay, DPST	34654	34654
10	Liquid Tight Connector	24685	24685
11	Cord Ass'y	4999-96	4999-96
12	Back Cover	36869	36869
13	Tube Support	41364	41364
14	Switch Box Cover	37047	37047
15	Terminal Box	36334-1	36334-1

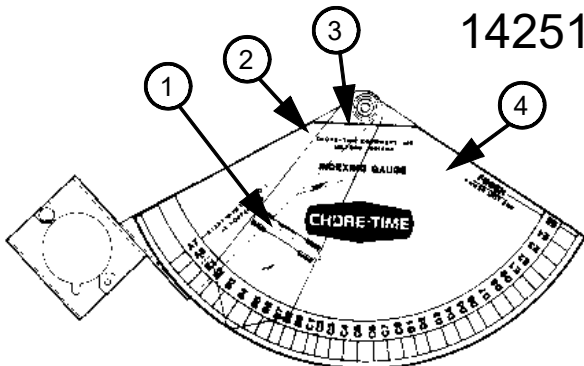

14251 Indexing Gauge

Item	Description	Part No.
1	Level Glass	4853
2	Gauge Clamp Weldment	14523
3	Pointer Assembly	4852
4	Indexing Gauge Decal	2529-207

Power Unit and Driver Assembly

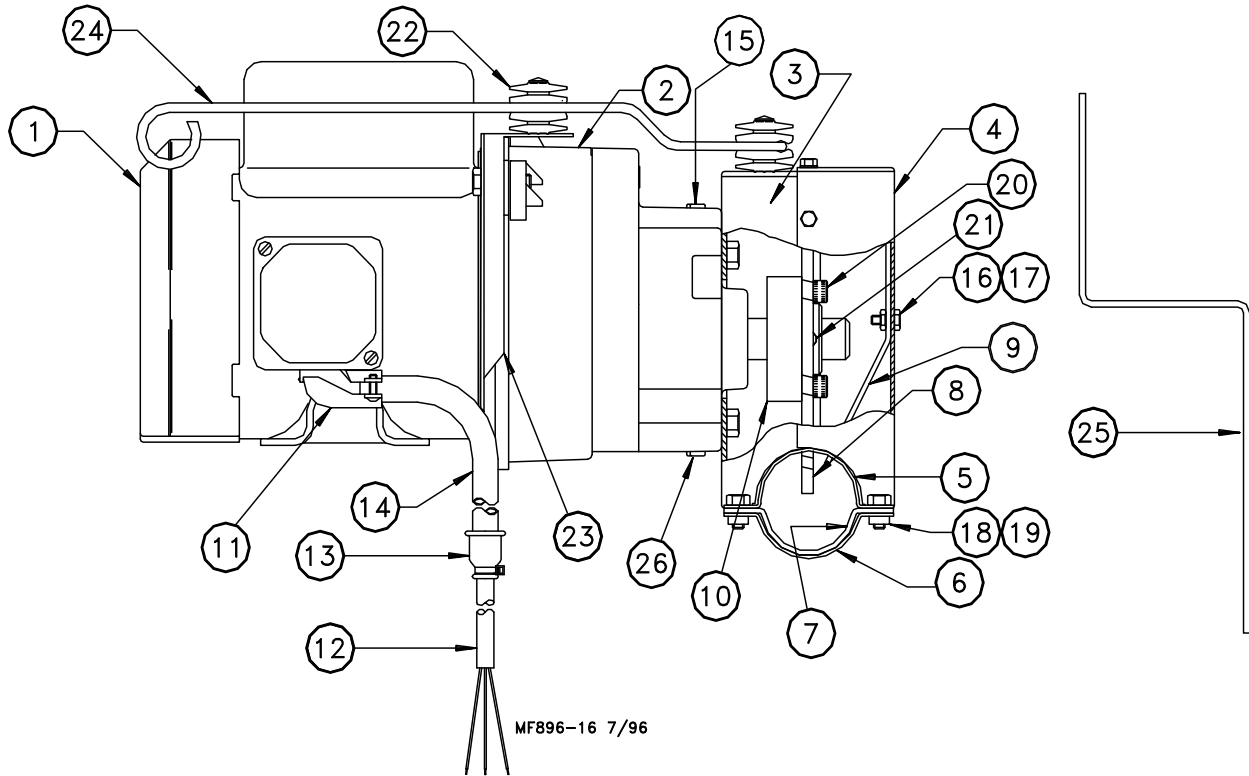

Item	Description	230V	200/230V	220V	220/380V
		60Hz 1 Ø 95 R.P.M. P/N 28841	60Hz 3 Ø 95R.P.M. P/N 37044	50Hz 1Ø 95 R.P.M. P/N 35387	50Hz 3 Ø 95 R.P.M. P/N 35388
		<u>Part No.</u>	<u>Part No.</u>	<u>Part No.</u>	<u>Part No.</u>
1	Motor 1/2HP	14750	28031EUR	5977	28031
2	Gearhead Assembly	3261-14	3261-14	3261-8	3261-8
3	Drive Unit Base	28149	28149	28149	28149
4	Drive Unit Cover	8208	8208	8208	8208
5	End Connector	9634	9634	9634	9634
6	Base Connector Weldment	9636	9636	9636	9636
7	Wear Shoe	8210	8210	8210	8210
8	Drive Sprocket	8463	8463	8463	8463
9	Auger Brace	24674	24674	24674	24674
10	Drive Gear Hub	8213	8213	8213	8213
11	90 degree Connector	4228	----	4228	----
12	Cord Assembly	27719	----	27719	----
13	Reducing Seal	7815	----	7815	----
14	Vinyl Tubing	7814	----	7814	----
15	Pipe Plug	3523	3523	3523	3523
16	10-24 x 1/2" Hex Head Screw	4416-3	4416-3	4416-3	4416-3
17	10-24 Locknut	34019	34019	34019	34019
18	1/4-20 x 1/2" Hex Head Screw	1487	1487	1487	1487
19	1/4-20 Locknut	1269	1269	1269	1269
20	5/16-18 SHCS	6850-1	6850-1	6850-1	6850-1
21	Dowel Pin	8699	8699	8699	8699
22	Insulator	2976	2976	2976	2976
23	Anti-roost Bracket	28156	28156	28156	28156
24	Anti-roost Wire	28150	28150	28150	28150
25	Anti-roost Wire	29695	29695	29695	29695
26	Magnetic Pipe Plug	30160	30160	30160	30160
--	1/8" Cable Clamp	14898	14898	14898	14898

47687 Power Winch

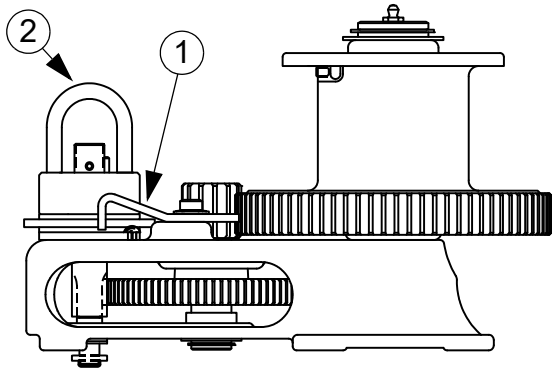

Item	Qty.	Description	Part No.
1	1	Pawl	47687-5
2	1	Input Shaft Assembly	47687-1

Miscellaneous Suspension Components

Item	Description	Part No.
1	3/32" Cable	4973
	3/16 Cable	1213
	1/8" Cable	27975
2	Cable Lock	14337
3	Pulley with Swivel	3004
4	Double eye Pulley	2501
5	Pulley	2500
6	3/16" Cable Clamp	732
	1/8" Cable Clamp	14898
7	Standard Screw Hook	1214
	ATF Screw Hook	2041
8	Pulley Assembly	28429
9	Suspension Bracket	28550
	w/ 10-16x1" screws	28832
10*	Handle Shank	3148
11**	Drill Adapter Shaft	2886
12*	Winch Handle Pin	3761
13	Winch Drive Tube (4')	2884-1
	Winch Drive Tube (8')	2884-2
	Winch Drive Tube (24")	2884-4

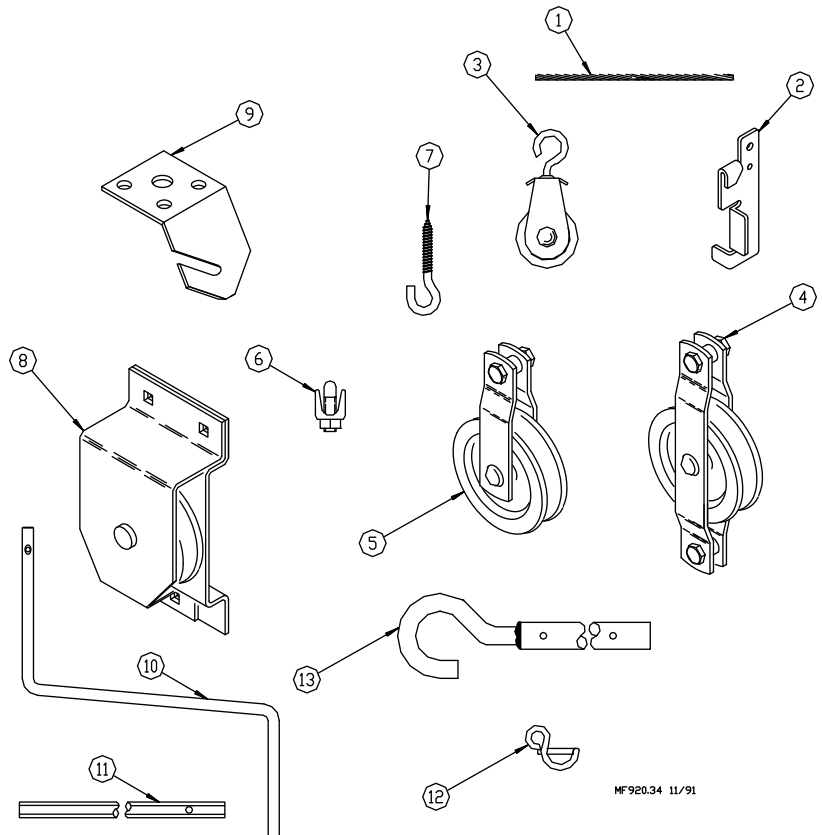

*Item 10 and Item 12 may be ordered as a kit under part no. 2885.

**Item 11 and Item 12 may be ordered as a kit under part no. 2886.

MF920.34 11/91

Maintaining the ULTRAPAN Feeder

The ULTRAPAN Feeder requires minimum maintenance. However, a routine periodic inspection of the equipment will prevent unnecessary problems.

Maintenance should be done by a qualified technician.

ALWAYS DISCONNECT POWER TO THE SYSTEM WHEN SERVICING OR MAINTAINING THE EQUIPMENT. FAILURE TO DISCONNECT POWER MAY CAUSE INJURY OR DEATH.

1. Replace the Plastic Shipping Plug in the power unit gear head with the Vented Plug during installation of the Power Unit.
2. Check the oil level in the gear heads at installation and every 6 months. The Pipe Plug, on the side of the gear head, indicates proper oil level. Add SAE 40W oil when necessary.
The oil in the gearheads should be replaced every 12 months with new SAE 40W oil.
 - A. Remove the bottom Pipe Plug to drain the oil. Discard used oil in accordance with local and national codes.
 - B. Wipe any debris off the magnet on the bottom Pipe Plug and reinstall. Remove the side Pipe Plug and (top) Vent Plug.
 - C. Set the power unit in the horizontal position.
 - D. 2-Stage Gearheads: Add approximately 9 oz. (266 ml) of SAE 40W oil through top hole. This should be just enough oil to reach the side Pipe Plug.
3-Stage Gearheads (3261-9, 3261-12, 3261-14): Add approximately 13 oz. (384 ml) of SAE 40W oil through top hole. This should be just enough oil to reach the side Pipe Plug.
 - E. Install the side Pipe Plug and (top) Vent Plug.
3. Check equipment for loose hardware. Tighten if necessary.
4. If the 41020 or 42016 Control Unit Switch requires adjustment, use the following procedure:
 - A. Detach the pan. Set it on floor under the control unit while adjustment is being made.
 - B. Remove Top Cover from the Control Unit to expose the switch.
 - C. Start feeder.
 - D. Refer to page 36 for detail instructions.
5. Keep anti-roost cables tightly stretched. This increases the effectiveness of the electro-guard anti-roost system and keep the pans from being tilted when birds push against them.
6. Remove all feed from the feeder when there are no birds in the house and when the building is washed and disinfected.
7. If the system is not to be used for an extended period of time, remove all the feed from the feeder lines and feeder pans.
Disconnect power to the system to prevent accidentally starting the system .
8. If the system must be disassembled, extreme caution must be used to prevent injury from springing auger.
 - A. Disconnect power to the entire system.
 - B. Remove the cover at the service section.

- C. Wearing protective clothing and protective glasses, use bolt cutters to cut the auger at the service section.

CAUTION: Stand clear...the auger may spring back into the tubes.

- D. Remove system components in the opposite order they were installed, according to this manual.

9. Replacing the batteries in the Agri-Timer:

- A. Disconnect electrical service at the breaker.
- B. Remove the (2) screws and the face of the timer.
- C. Replace the existing batteries with new batteries.
- D. Use existing wire ties to secure the new batteries in place.
- E. Reinstall the face of the timer and secure using (2) screws previously removed.
- F. Reconnect electrical service to the Breeder Control.

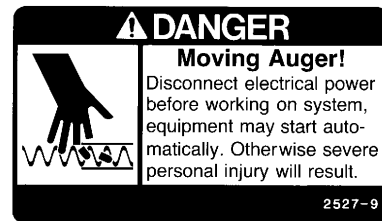

NOTES

A large, empty rectangular box with a thin black border, intended for handwritten notes.



**Made to work.
Built to last.™**

Revisions to this Manual

Page No

58

Various

Description of Change

Was 2883 Winch

Updated Graphics

**For additional parts and information, contact your nearest Chore-Time distributor or representative.
Find your nearest distributor at: www.choretime.com/contacts**

CTB, Inc.
PO Box 2000
Milford, Indiana 46542-2000 USA
Phone (574) 658-4101
Email: choretime@choretime.com
Internet: www.choretime.com