

CHORE-TIME®

ULTRAFLO® Breeder Feeder Feeding System

Installation and Operators
Instruction Manual



For additional parts and information, contact your nearest Chore-Time distributor or representative.
Find your nearest distributor at: www.choretime.com/contacts

CTB, Inc.
PO Box 2000
Milford, Indiana 46542-2000 USA
Phone (574) 658-4101 Fax (877) 730-8825
Email: choretime@choretime.com
Internet: www.choretime.com

Chore-Time Limited Warranty

CTB, Inc. (“Chore-Time”) warrants each new CHORE-TIME Breeder Feeder product manufactured by Chore-Time to be free from defects in material or workmanship under normal usage and conditions, for One (1) year from the date of installation by the original purchaser (“Warranty”). Chore-Time provides for an extension of the aforementioned Warranty period (“Extended Warranty Period”) with respect to certain Product parts (“Component Part”) as set forth in the table below. If such a defect is determined by Chore-Time to exist within the applicable period, Chore-Time will, at its option, (a) repair the Product or Component Part free of charge, F.O.B. the factory of manufacture or (b) replace the Product or Component Part free of charge, F.O.B. the factory of manufacture. This Warranty is not transferable, and applies only to the original purchaser of the Product.

Component Part	Extended Warranty Period
RXL Fan (except motors and bearings)	Three (3) Years
TURBO® Fan (except motors and bearings)	Three (3) Years
TURBO® Fan fiberglass housing, polyethylene cone, and cast aluminum blade.	Lifetime of Product
TURBO® fan motor and bearings.	Two (2) Years
Chore-Time® Poultry Feeder Pan	Three (3) Years
Chore-Time® Rotating Centerless Augers (except where used in applications involving high moisture feed stuffs exceeding 17%)	Ten (10) Years
Chore-Time Steel Auger Tubes	Ten (10) Years
ULTRAFLO® Breeder Feeding System auger and feed trough.	Five (5) Years
ULTRAPAN® Feeding System augers .	Five (5) Years

CONDITIONS AND LIMITATIONS

THIS WARRANTY CONSTITUTES CHORE-TIME’S ENTIRE AND SOLE WARRANTY AND CHORE-TIME EXPRESSLY DISCLAIMS ANY AND ALL OTHER WARRANTIES, INCLUDING, BUT NOT LIMITED TO, EXPRESS AND IMPLIED WARRANTIES, INCLUDING, WIHTOUT LIMITATION, WARRANTIES AS TO MERCHANTABILITY OR FITNESS FOR PARTICULAR PURPOSES. CHORE-TIME shall not be liable for any direct, indirect, incidental, consequential or special damages which any purchaser may suffer or claim to suffer as a result of any defect in the Product. Consequential or Special Damages as used herein include, but are not limited to, lost or damaged products or goods, costs of transportation, lost sales, lost orders, lost income, increased overhead, labor and incidental costs, and operational inefficiencies. *Some jurisdictions prohibit limitations on implied warranties and/or the exclusion or limitation of such damages, so these limitations and exclusions may not apply to you. This warranty gives the original purchaser specific legal rights. You may also have other rights based upon your specific jurisdiction.*

Compliance with federal, state and local rules which apply to the location, installation and use of the Product are the responsibility of the original purchaser, and CHORE-TIME shall not be liable for any damages which may result from non-compliance with such rules.

The following circumstances shall render this Warranty void:

- Modifications made to the Product not specifically delineated in the Product manual.
- Product not installed and/or operated in accordance with the instructions published by the CHORE-TIME.
- All components of the Product are not original equipment supplied by CHORE-TIME.
- Product was not purchased from and/or installed by a CHORE-TIME authorized distributor or certified representative.
- Product experienced malfunction or failure resulting from misuse, abuse, mismanagement, negligence, alteration, accident, or lack of proper maintenance, or from lightning strikes, electrical power surges or interruption of electricity.
- Product experienced corrosion, material deterioration and/or equipment malfunction caused by or consistent with the application of chemicals, minerals, sediments or other foreign elements.
- Product was used for any purpose other than for the care of poultry and livestock.

The Warranty and Extended Warranty may only be modified in writing by an officer of CHORE-TIME. CHORE-TIME shall have no obligation or responsibility for any representations or warranties made by or on behalf of any distributor, dealer, agent or certified representative.

Effective: **April, 2014**

CTB, Inc.
 PO Box 2000
 Milford, Indiana 46542-2000 USA
 Phone (574) 658-4101
 Email: choretime@choretime.com
 Internet: www.choretime.com

Contents

Topic	Page
Chore-Time Limited Warranty	2
Safety and General Information	5
Follow Safety Instructions.....	5
Decal Descriptions.....	5
DANGER: Moving Parts.....	5
DANGER: Electrical Hazard.....	5
Glossary of Terms	6
Trough & Grill.....	6
Manual Winch.....	6
Throw Back.....	6
Breeder Control.....	6
Power Unit & Driver Ass’y.....	6
Introduction	7
Planning the System.....	8
Installation	10
150LB Plastic Hopper.....	10
Assembly.....	10
Suspending the Hopper.....	10
Suspension System Installation.....	11
Suspension Systems over 250’ [76m] system.....	12
Suspension systems up to 250’ [76m].....	13
Manual Winch Installation.....	14
Screw Hook/Ceiling Hook Installation.....	16
Narrow Steel Truss Installation.....	16
Steel Truss Welded Installation.....	16
Wide Steel Truss Installation.....	17
Wood Truss Installation.....	17
Wood Truss Installation.....	17
Suspension Drop Line Installation.....	18
ULTRAFLO® Breeder Feeder Line Components Installation.....	20
Trough Hanger Installation.....	20
Intake Boot Installation.....	21
Connecting Trough Sections together.....	22
Power Unit Base Installation.....	22
Clean Out Installation.....	23
Elbow Installation.....	25
Auger Installation.....	26
Auger Brazing.....	27
Power Unit Installation.....	28
Grill Installation (Standard and Hi-Contour).....	30
Hopper Installation.....	31
Securing Hopper to Intake Boot.....	32
Suspending the System.....	32
Installing the Fill System.....	33
Installation of the Weigh-Matic Scales.....	33
Bin Location & Scale Preparation.....	34
7’ (2.13 m) Storage Bin and Weigh Bin using (2) Pads.....	35
7’ (2.13 m) Storage Bin and Weigh Bin using (1) Pad.....	35
11’ (3.35 m) Storage Bin and Weigh Bin using (2) Pad.....	36
11’ (3.35 m) Storage Bin and Weigh Bin using (1) Pad.....	36
5978 Template for Winslow Scale.....	37

Anchor Bolt Setting	38
Scale Stand Locations	38
Feed Bin Installation	42
Installation of the FLEX-AUGER Fill System	42
WEIGH-MATIC® Model 90 Screener	43
Controlling the Feeder	44
34380 Breeder Control Features	44
Time Clock Operation	45
Programming the 4-Channel Time Clock	46
ULTRAFLO Breeder Feeder Component Location Diagram	48
Balancing the Scales	49
Operation of the Scales	49
Start Up Procedure	50
Wiring	51
34380 Breeder Control Wiring (Without Motor Starters)	51
34380 Breeder Control Wiring (With Motor Starters)	52
34380 Breeder Control Wiring (With Motor Starters 3 Phase)	53
Chore-Time Digital Weigh-Matic Wiring Diagram	54
Alternate Scale Wiring Diagram	55
Additional Channel Wiring	55
Logic Wiring	56
Internal Wiring	57
30240 Fill Option Breeder Control Wiring (W/out Motor Starter Single Phase)	58
For ULTRAFLO® Breeder Feeder Installations without Motor Starters (230V,50/60Hz,Single Phase)	58
30240 Fill Option Control Logic Wiring	59
Parts Listing	60
Breeder Control: Part No. 34380	60
ULTRAFLO® Breeder Feeder Line Components	61
ULTRAFLO® Breeder Feeder Grill Options	63
ULTRAFLO® Boot Assembly (Part No. 35580)	64
Power Unit and Driver Assembly	65
WEIGH-MATIC® Model 90 Screener (Part No. 25432)	66
Screener Control Unit	67
Junction Box Assembly (Part No. 25694)	67
Screener Control Unit 46800-23	68
Screener Power Unit (50 and 60hz)	69
Fill System Power Unit (50 and 60hz)	70
Weigh Scale Assembly	71
5978 Scale Template Assembly	71
5790 Beam Box Assembly	72
5,000 lbs. Weigh Beam Assembly (Part No. 9447)	73
8,000 lbs. Weigh Beam Assembly (Part No. 6514)	73
Miscellaneous Suspension Components	74
Clean-Out Assembly Kit (Part No. 35875)	75
Winch (Part No. 47687)	75
Troubleshooting	77
Maintenance	79
Miscellaneous Maintenance Notes	80
Component Weight Chart	80
Management Procedure for Day Old to End of Lay Applications	81
General Management Guide	82

Safety and General Information

Caution, Warning and Danger Decals have been placed on the equipment to warn of potentially dangerous situations. Care should be taken to keep this information intact and easy to read at all times. Replace missing or damaged safety decals immediately.

Safety–Alert Symbol



This is a safety–alert symbol. When you see this symbol on your equipment, be alert to the potential for personal injury. This equipment is designed to be installed and operated as safely as possible...however, hazards do exist.

Understanding Signal Words

Signal words are used in conjunction with the safety–alert symbol to identify the severity of the warning.



DANGER indicates an imminently hazardous situation which, if not avoided, **WILL** result in death or serious injury.



WARNING indicates a potentially hazardous situation which, if not avoided, **COULD** result in death or serious injury.



CAUTION indicates a hazardous situation which, if not avoided, **MAY** result in minor or moderate injury.

Follow Safety Instructions

Carefully read all safety messages in this manual and on your equipment safety signs. Follow recommended precautions and safe operating practices.

Keep safety signs in good condition. Replace missing or damaged safety signs.

Caution!



Use caution when working with the Auger--springing auger may cause personal injury.

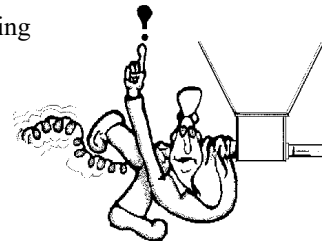

Decal Descriptions

DANGER: Moving Parts

Disconnect electrical power before working on system, equipment may start automatically. Otherwise personal injury will result.

Severe personal injury will result if the equipment is operated without covers properly installed.

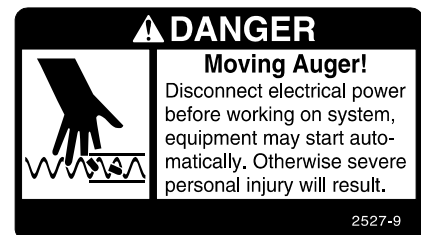

DANGER: Electrical Hazard

Disconnect electrical power before inspecting or servicing equipment unless maintenance instructions specifically state otherwise.

Ground all electrical equipment for safety.

All electrical wiring must be done by a qualified electrician in accordance with local and national electric codes.

Ground all non-current carrying metal parts to guard against electrical shock.

Electrical disconnects and over current protection are not supplied with the equipment.



Glossary of Terms

Trough & Grill

•The ULTRAFLO® is a trough feeder that uses an open auger to carry feed around the loop. The Grill is required to provide a uniform eating environment and also helps to prevent the trough from spreading.

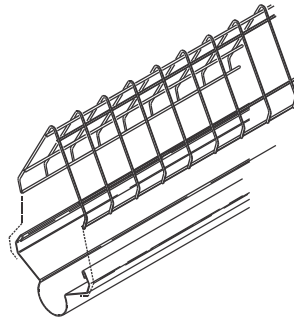

Manual Winch

•Red, cast iron winch used to raise and lower the feeder line(s). Operated by a hand crank.

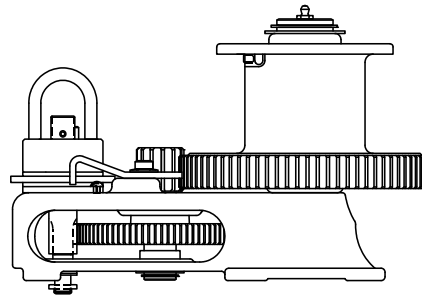

Throw Back

•A cable/pulley arrangement that allows cable to be routed to a desired location.

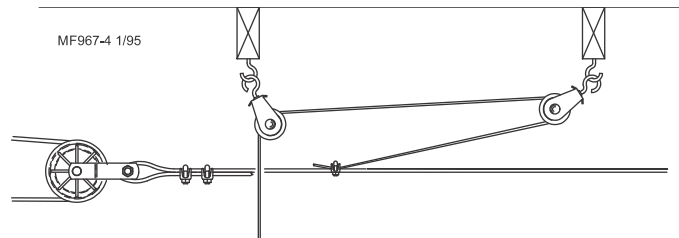

Breeder Control

•The ULTRAFLO® is controlled using the 34380 Breeder Control. The Breeder Control may be programmed to preset start times, run times, fill system start times, etc.

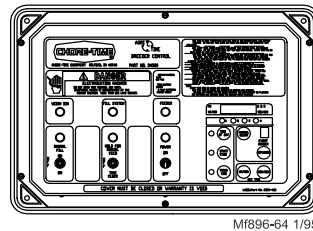

Power Unit & Driver Ass'y

•The Power Unit and Driver Assembly drive the Auger delivery feed around the feeder loop.

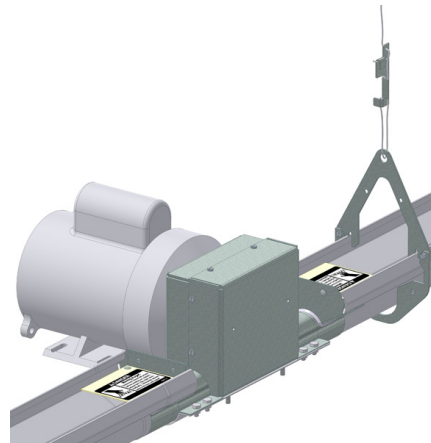

Introduction

Chore-Time has designed the ULTRAFLO[®] Breeder Feeder to feed breeder hens faster and with less stress than conventional feeders.

Feed is delivered to the hopper(s) by a Chore-Time FLEX-AUGER System. Feed is drawn out of the hoppers by the ULTRAFLO[®] Breeder Feeder Auger. Chore-Time does not recommend feeding pellets with the ULTRAFLO[®] Breeder Feeder.

The system is designed to feed 4-6 birds per foot (25 birds per meter) of trough. The feeder will deliver feed at a rate of 100 feet (30 m) per minute. The Breeder Feeder Auger will hold approximately 1/2 pound of feed per foot (.75 kg of feed per meter).

The auger serves as a stirring device as it delivers feed around the loop.

The ULTRAFLO[®] Breeder Feeder Control uses 4-Channel Breeder Control. The fill system and feeder line is controlled by separate channels. The length of run time will be set when the system is first operated. The length of run time is adjustable and may be set and changed at the Breeder Control.

Early in the rearing period the amount of feed to be fed each day may only fill part of the trough. Later in the rearing period the amount of feed to be fed may fill the trough once, but not fill all of the trough during the second serving.

Planning the System

Carefully planning the system prior to beginning the installation will save time and effort.

Adequate overhead structure must be provided to support the weight of the feeder, hoppers, power units, etc. Refer to the “**Component Weight Chart**” on page 80 for individual component weights.

ULTRAFLO Broiler Breeder applications use a Nylon Elbow Loop Kits.

Commercial Layer applications use Hardened Steel Elbow Loop Kits.

Figure 1, shows a house with (2) ULTRAFLO® Breeder Feeder Loops. The purpose of the first loop is to show the recommended placement of the power units, hoppers, and weigh bin.

FOR HOUSES UP TO 350’ (106 M), two power units are recommended. These power units should be evenly spaced opposite each other. For a 350’ (106 m) house the power units should be placed in positions “3” and “8” **See Figure 1 (on page 8)**. Notice that the power units are located one trough section from the hoppers.

FOR HOUSES FROM 351’ TO 450’ (106 TO 137 M), three power units are recommended. To determine the proper placement of the three power units, add the total length of the system, including 5’ (1.5 m) for each 90 degree elbow, and divide by 3. This will give an approximate number of feet between power units, round up or down to the nearest suspension drop line. These power units should be staggered (two on one side of the loop, one on the other side). The power units should be placed in positions “3”, “10”, and “6” (**See Figure 1**). The power unit in position “3” should be located one trough section away from the hopper.

For houses from 451’ to 600’ (137 to 182 m), four power units are recommended. These power units should also be spaced evenly around the system. To determine the proper placement of the power units, add the total length of the system, including 5’ (1.5 m) for each 90 degree elbow, and divide by 4. This will give an approximate distance between power units, round up or down to the nearest suspension drop line. The power units should be evenly spaced directly across from each other in the system. The power units should be placed in positions “2”, “10”, “5”, and “6” (**See Figure 1**).

The second loop provides some dimensional specifications.

Notice that the suspension drop lines are spaced 8’ (2.4 m) or 10’ (3 m) apart all through the system. Be sure to properly suspend the elbows.

The ULTRAFLO® Breeder Feeder loop is 5’ (1.5 m) wide (minimum). Additional width may be achieved by adding a straight section of tube between elbows.

DO NOT place power units within 50 feet (15.2 m) of elbows.

Standard system layout for ULTRAFLO® Breeder Feeder using (2) Hoppers per loop.

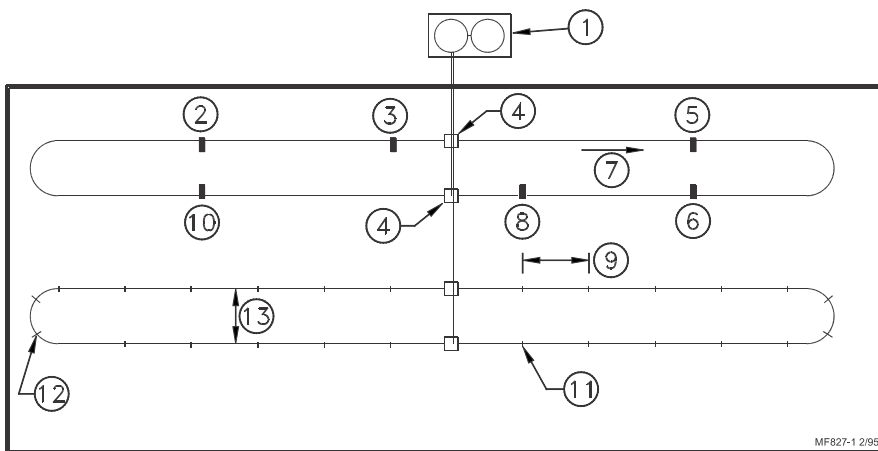

Figure 1. System Layout Diagram for systems using (2) Hoppers per loop. (Top View).

Length of Feeder Line	Power Unit Position
Up to 350 feet (106 m)	“3” and “8”
351 to 450 feet (106 to 137 m)	“3”, “10”, and “6”
451 to 600 feet (137 to 182 m)	“2”, “10”, “5”, and “6”

Item	Description
1	Weigh Bin and Scales
2	Power Unit
3	Power Unit
4	Feed Hopper
5	Power Unit
6	Power Unit
7	Auger Travel
8	Power Unit
9	8’ [2.4m] centers recommended. 10’ [3m] centers max.
10	Power Unit
11	Suspension Drop Line
12	Provide adequate support to prevent elbow sagging.
13	5’ [1.5m]

Figure 2, shows a similar house except only ONE hopper is supplying each ULTRAFLO® Breeder Feeder Loop. **DO NOT INSTALL THIS SYSTEM LAYOUT IN HOUSES THAT EXCEED 250' (76 M).**

Power Unit locations are different for single hopper systems. Notice the Power Units are located in the center of the house.

Standard system layout for ULTRAFLO® Breeder Feeder using (1) Hopper per loop.

Note: House length not to exceed 250' [76m]

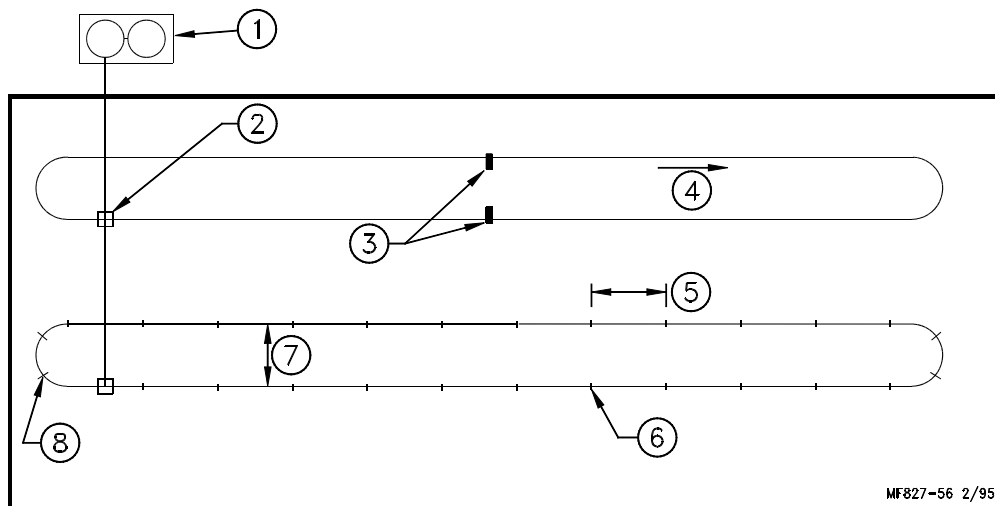

Item	Description
1	Weigh Bin and Scales
2	Feed Hopper
3	Power Unit
4	Auger Travel
5	10' [3m] centers
6	Suspension Drop Line
7	5' [1.5m]
8	Provide adequate support to prevent the elbows from sagging

Figure 2. System Layout Diagram for systems using (1) Hopper per loop. (Top View).

Installation

150LB Plastic Hopper

The 150 lb. Hopper Assembly is **NOT designed for single-point suspension**. The upper cross brace is designed for supporting the drop tube **ONLY**. This Hopper Assembly is to have **Two-point** suspension as stated below.

Assembly

1. If hopper assembly was ordered with lower hopper switch, assemble the switch to the machined hopper half. See Figure 3.
2. Assemble the 1/4-20 x 1-1/2" bolt to the brace with two 1/4-20 nuts. One nut should be assembled under the brace with the other on top. This bolt is to provide a place for the tube support assembly chain to be hooked.
3. Assemble the 150 lb. hopper halves and brace as shown using #14 x 5/8" screws (supplied in hardware package).
4. Assemble the #8 x 1/2" screws and chain.
5. Assemble suspension angles and suspension braces around feeder line boot (single or twin), using 1/4-20 x 1/2" Hex bolts and nuts (supplied in hardware package). See Figure 4.

Note: The larger holes on the ends of the suspension angles need to be on the upper side of the assembly.

6. Assemble the twist lock collar to the top of the feeder line boot (single or twin) using 1/4-20 x 1/2" bolts and lock nuts (supplied in hardware package). See Figure 4.

Note: Installation for single boot applications may require a 9/32" hole to be drilled in one end of the boot to attach the twist lock collar. Bolt one end of the twist lock collar to the boot then mark and drill the second hole using the twist lock collar as a template.

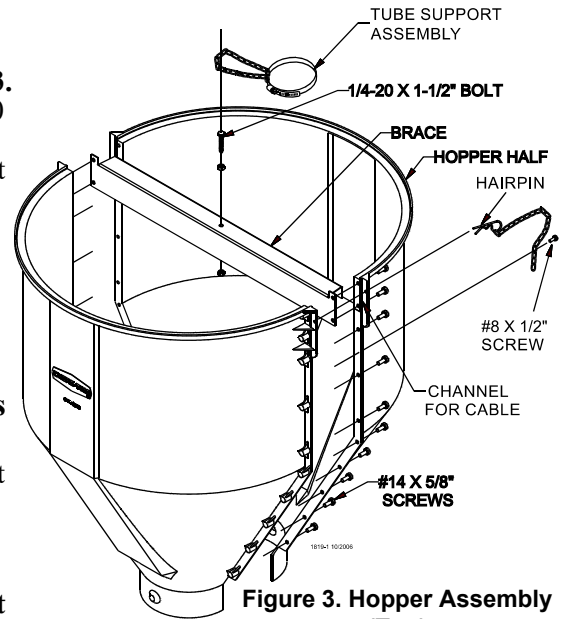

Figure 3. Hopper Assembly (Top)

7. Assemble the adjustment brackets to the suspension angles with 5/16-18 x 3/4" bolts and nuts (supplied in hardware package).
8. Two cable assemblies (cable with a sleeve clamp and a 5/32 thimble) are supplied with the suspension kit to support the hopper. Attach the cable assemblies to the adjustment brackets using the top holes of the adjustment brackets. See Figure 4.
9. Install two pulleys to either a 2" x 8" [50 x 200 mm] board with will span at least 3 rafters or a 3/8" [9.5 mm] thick steel plate welded to two pieces of angle iron that are long enough to span 2 rafters. Install the pulleys directly above the feeder line where the hopper is to be located. The pulleys should be spaced 22" [559 mm] apart (11" [279 mm] from the center of the hopper in both directions).

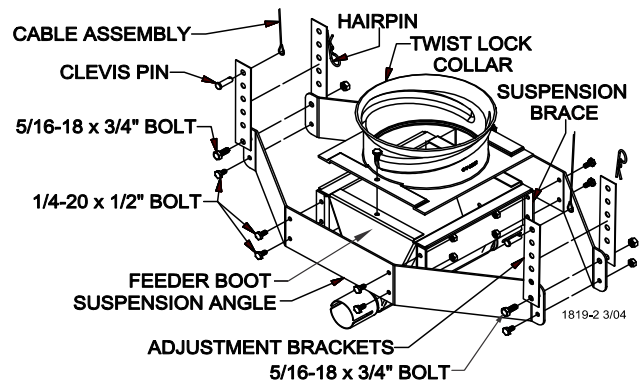

Figure 4. Hopper Assembly (Bottom)

Suspending the Hopper

1. Attach the boot to the feeder line.
2. Route the two cable assemblies up and around the pulleys.
3. Level the boot with the feed line and clamp the cables to the main cable using 1 cable clamp per cable assembly.
4. Place the hopper on top of the twist lock collar and rotate the hopper 90 degrees into position.

Note: Make sure the cables lay in the channels on the sides of the hopper for support then use the hairpin to contain the cable.

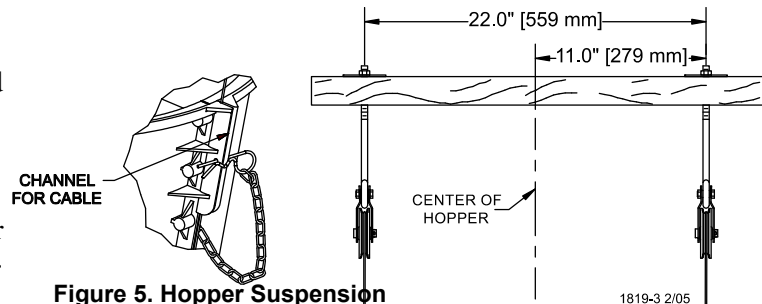

Figure 5. Hopper Suspension

Suspension System Installation

The feeder line suspension is a vital part of your feeding system. Take time to thoroughly plan the system to insure proper operation. **Figure 6. on page 12** provides an overview of the suspension required for systems 250 feet (76 m) or more. **Figure 7. on page 13**, provides an overview of the suspension system for installations 250' (76 m) or less, using (1) hopper. Enlarged, detail drawings show critical suspension information.

Specific installation instructions for miscellaneous suspension components are provided in this manual.

STRAIGHT LINE SUSPENSION SYSTEMS UP TO 350 FEET (106 M): A separate winch and suspension system is required to raise (and lower) each side of the ULTRAFLO[®] Feeder. Double-backs are not required.

NOTE: Double-backs are not required on straight line lengths from 250 feet (76 m) to 350 feet (106 m). All other systems require double-back(s), as shown.

STRAIGHT LINE SUSPENSION SYSTEMS OVER 350 FEET (106 M): A separate winch and suspension system is required to raise (and lower) each side of the ULTRAFLO[®] Feeder. Double-backs are required at each winch, as shown in **Figure 6. on page 12**. Two cable clamps are required to connect the main cable to the Double Back Pulley.

LOOP SUSPENSION SYSTEMS UP TO 250 FEET (76 M): A single winch and suspension system is required to raise (and lower) the entire ULTRAFLO[®] Feeder. Double-backs are required at the winch, as shown in **Figure 7. on page 13**, and Detail A. Two cable clamps are required to connect the main cable to the Double Back Pulley. Special Pulley Assemblies are required to route the cable, as shown in Detail E.

IMPORTANT: A suspension drop line must be provided on each side and directly above each power unit, gearhead, and feed hopper. See Details B & C.

Determine where the feeder line is to be installed. Mark a straight line on the ceiling or rafters the full length of the feeder line. Use a string, chalk line, or the winch cable, temporarily attached with staples, to mark the line. Center the line directly over where the feeder is to be installed.

Two cable clamps are required to connect the main cable to the Double Back Pulley.

One cable clamp is required to connect each drop line to the main cable.

12 Suspension Systems over 250' [76m] system

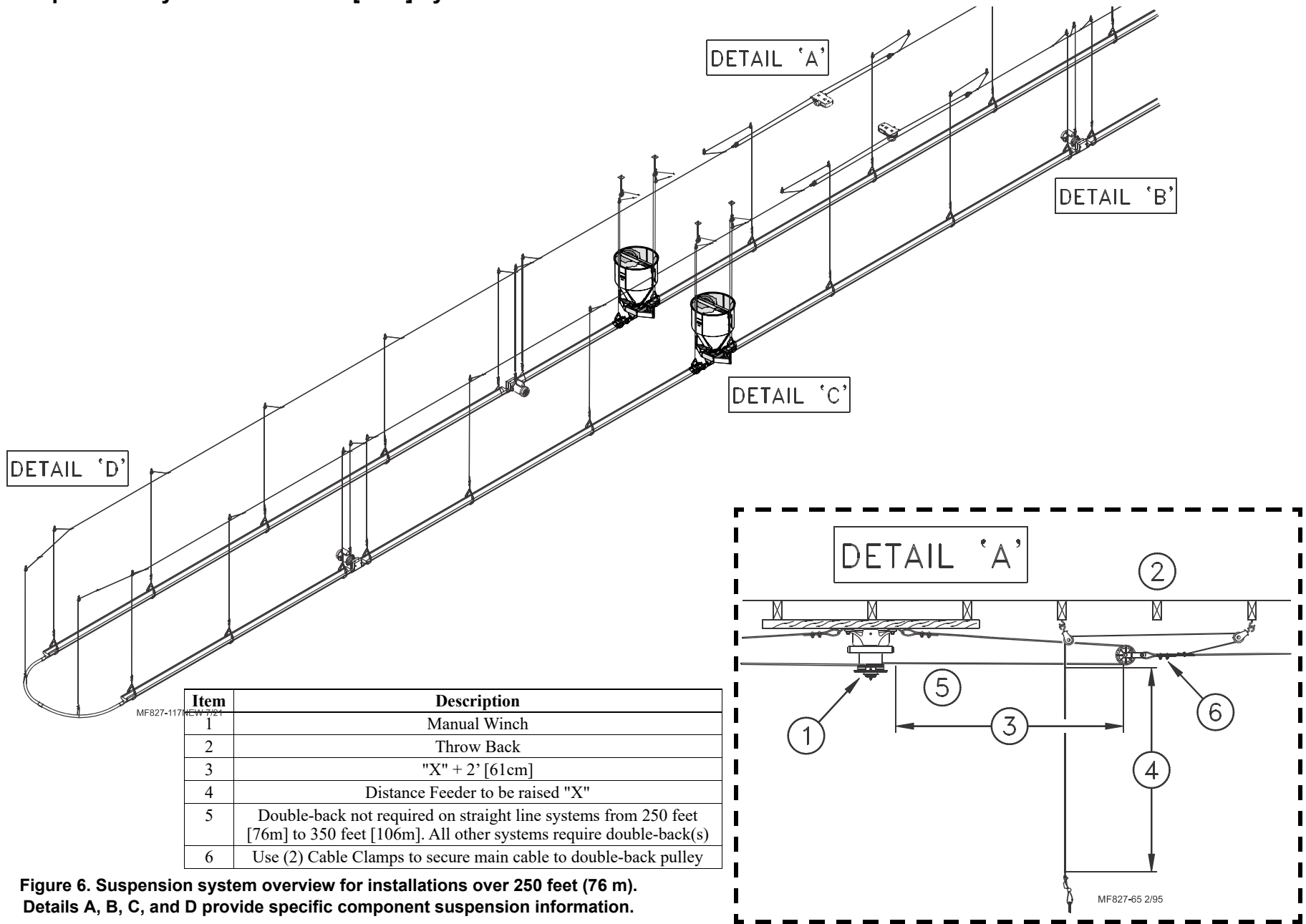
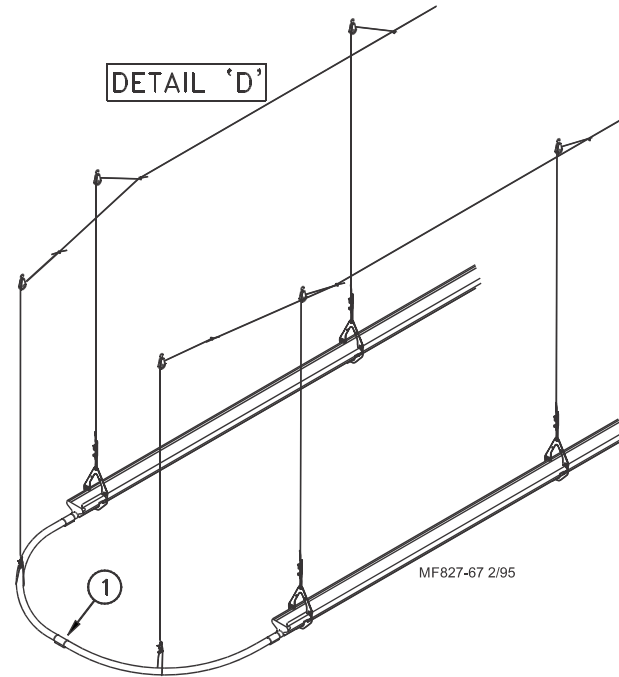
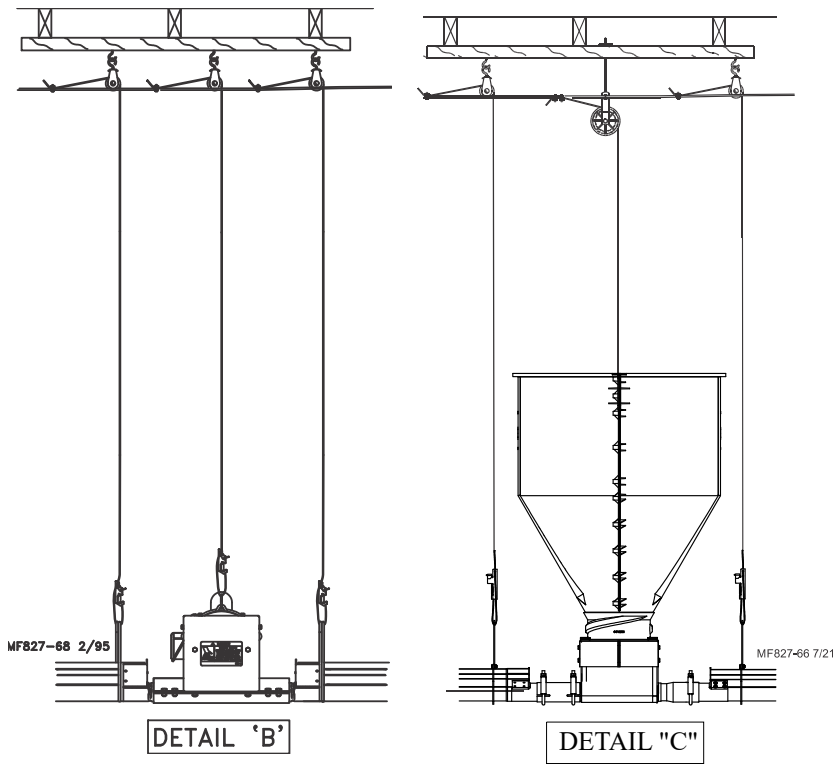

Figure 6. Suspension system overview for installations over 250 feet (76 m). Details A, B, C, and D provide specific component suspension information.

Suspension systems up to 250' [76m]



Item	Description
1	Provide additional support for the center of the Elbows.

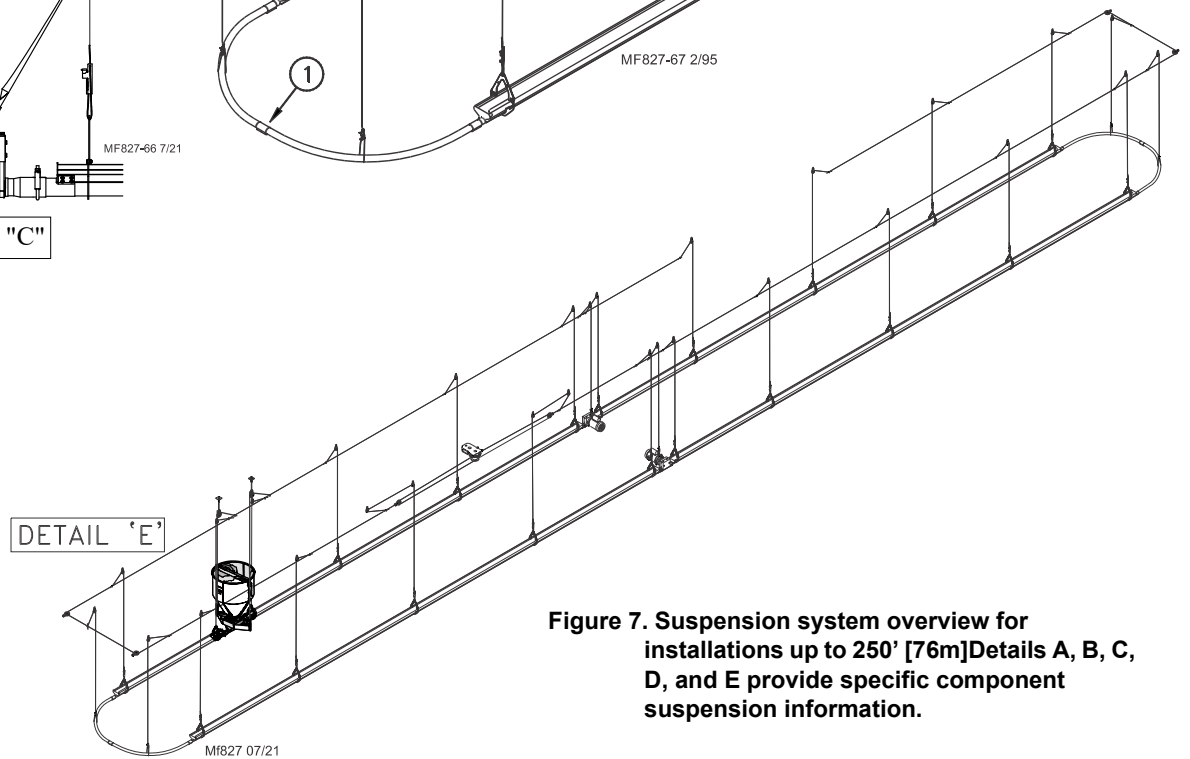
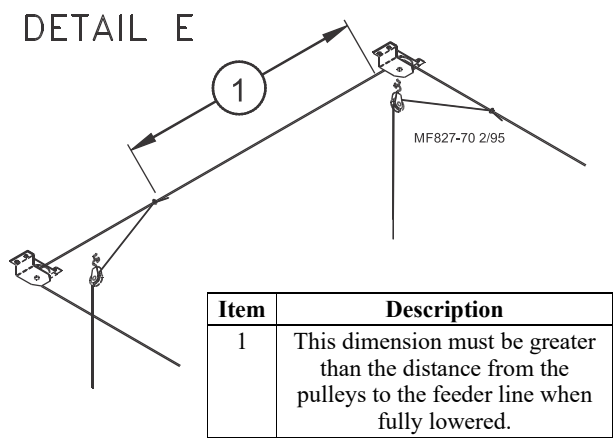

Figure 7. Suspension system overview for installations up to 250' [76m] Details A, B, C, D, and E provide specific component suspension information.

Manual Winch Installation

1. Bolt the Manual Winch, fully assembled, to a 2x8 (50x200 mm) board that will span at least 3 rafters. The brake mechanism will protrude on one side.

For feeder lines over 350 feet (106 m), install a 2985 Cable Hook between the mounting bolt and Manual Winch frame, as shown in **Figure 8**.

For loop suspension systems, install a 2985 Cable Hook between the mounting bolt and Manual Winch frame, as shown in **Figure 8**.

Item	Description
1	Manual Winch
2	Cable Hook
3	2" x 8" [50 x 200mm] board that spans (3) three Rafters
4	5/16-18 x 2-1/2" Bolt, washer and Lock Nut

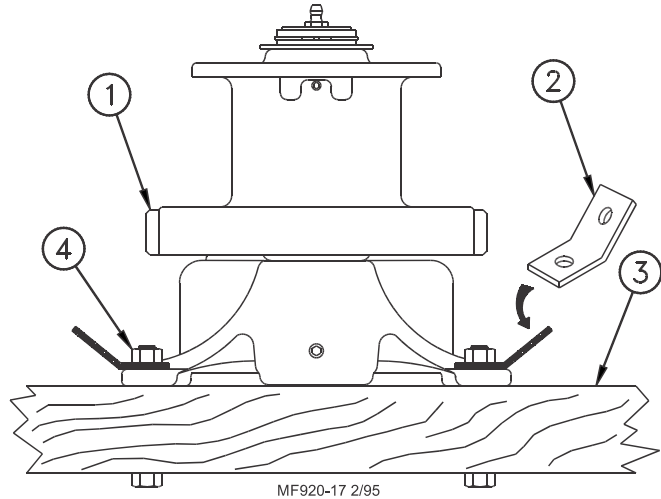

Figure 8. Winch Mounting Diagram (End View)

2. Attach the 2"x8" (50x200 mm) board, with the Manual Winch secured, to the ceiling at the center of the feeder line. The 2"x8" (50x200 mm) must be parallel to the line and must span at least 3 rafters. Lag bolts are required, not supplied.

If the hopper is located at the center of the feeder line, locate the Manual Winch a few feet offset from the center of the feeder line.

3. Extend the 3/16" (5 mm) cable the full length of the feeder line. Attach the cable temporarily to the ceiling with nails, staples, or some type of fastener.
4. Route the cable through the winch drum relief located near the bottom of the drum. Tighten the set screw to anchor the cable to the drum. (See **Figure 9**.)

Item	Description
1	Winch Drum Relief with Set Screw
2	3/16" Winch Cable
3	Drum Rotation

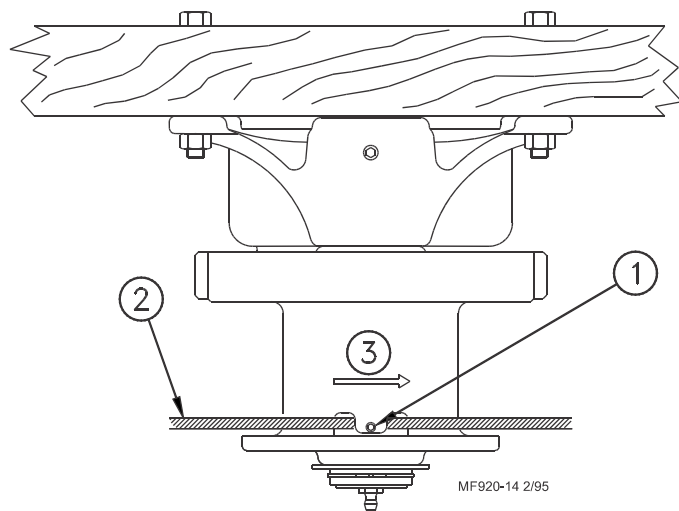

Figure 9. Winch Cable Installation (End View)

5. Turn the winch drum one full revolution. Guide the cable against the flange at the bottom of the winch drum. The cable must not wrap over itself on the drum, but should be wrapped as close as possible to each previous wrap. (See Figure 10.).

Item	Description
1	Drum Rotation

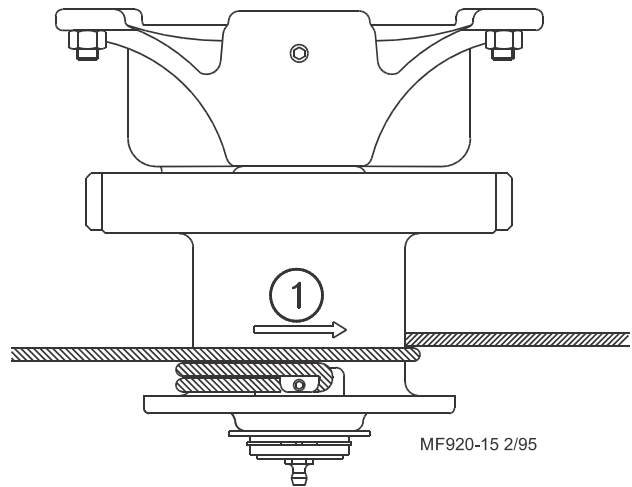

Figure 10. Cable Wrapping (End View)

The recommended distance between the drops is 8' (2.4 m) on center. Do not exceed 10' (3 m) spacing on drop lines.

If the distance raised is greater than the distance between the drop spacings, offset the hooks 3 inches (75 mm) to each side of the line to prevent the cable clamps from catching the pulleys. (See Figure 11.).

Item	Description
1	3/16" Winch Cable
2	Screw Hook or Ceiling Hook location
3	3/32" Drop Cable
4	Offset the drop lines if this distance is less than Item 5
5	Cotter Pin
6	Adjustment Bracket
7	Hair Pin
8	Hopper Side
9	Switch Mount Bracket
10	Boot Hanger

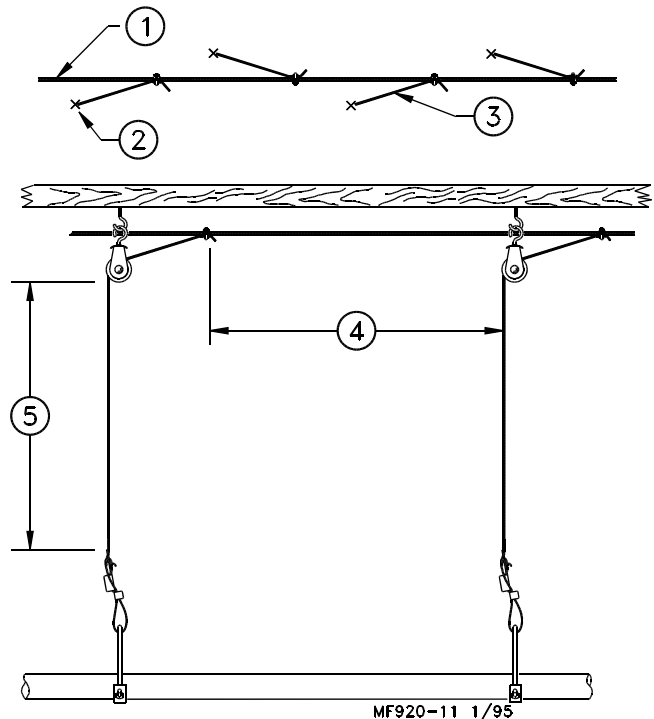

Figure 11. Drop Line Offset Detail

Screw Hook/Ceiling Hook Installation

Screw Hooks or Ceiling Hooks may be used to suspend the feeder line. Refer to the appropriate instruction, below. Screw Hook installation is shown in **Figure 12**. Ceiling Hooks installation is shown in **Figure 12** through **19**.

Screw the hook into the truss the full length of the threads to prevent bending. The openings of the screw hooks must be pointed away from the direction of travel when the Power Winch raises the feeder line. (See **Figure 12**.)

Item	Description
1	Screw Hook Opening facing opposite direction of travel
2	Direction of Cable pull when raising Feeder Line
3	3/16" Drop Cable
4	3/32" Drop Cable

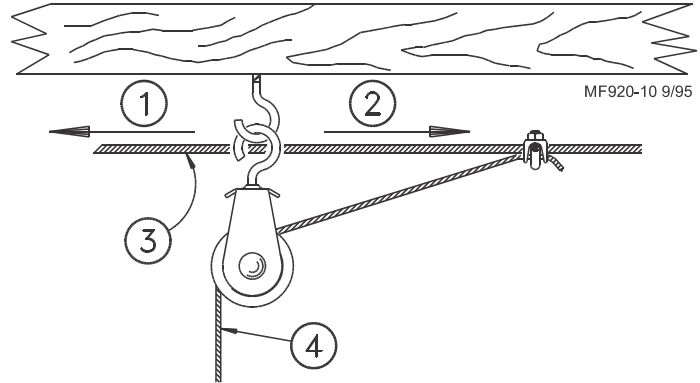

Figure 12.Screw Hook Installation (Side View)

Narrow Steel Truss Installation

The Ceiling Bracket (**28550**) may be used in a variety of installations. Depending on your individual situation, install the Ceiling Brackets as shown in **Figure 13** through **Figure 16**.

After securing the Ceiling Bracket to the truss, slide the hook of a Swivel Pulley into the slot, as shown in **Figure 13**.

Item	Description
1	Secure Ceiling Bracket to Truss using self-drilling Screws through side by side holes.
2	Cable Travel

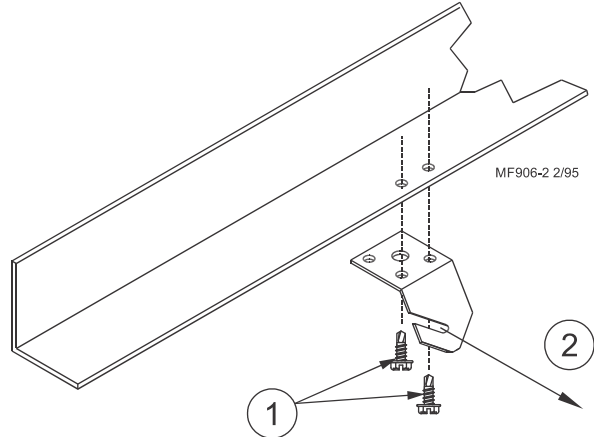

Figure 13.Narrow Steel Ceiling Hook Installation

Steel Truss Welded Installation

Item	Description
1	Weld Ceiling Hook to Truss here
2	Cable Travel

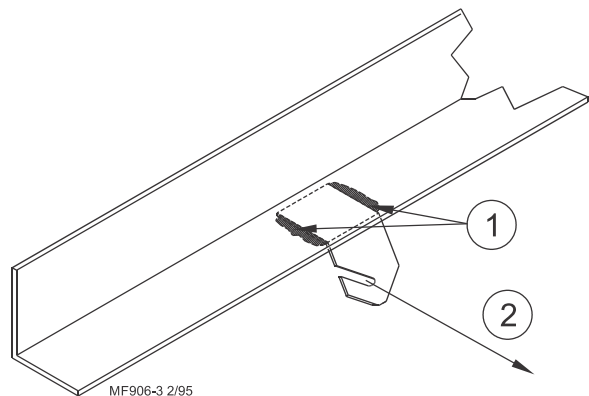

Figure 14.Steel Weld Ceiling Hook

Wide Steel Truss Installation

Item	Description
1	Secure Ceiling Hook to Truss using self-drilling Screws through opposite holes.
2	Cable Travel

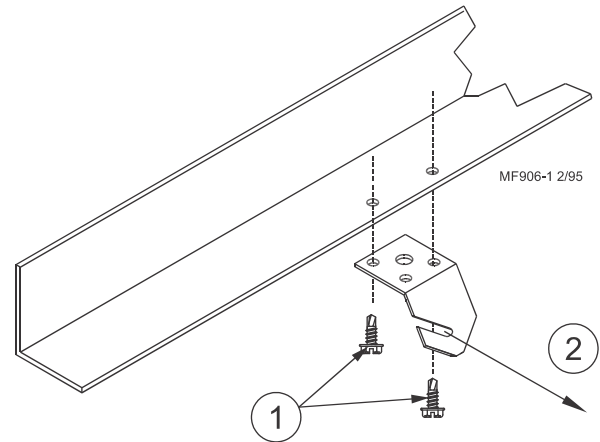

Figure 15. Wide Steel Ceiling Hook

Wood Truss Installation

Item	Description
1	Secure Ceiling Hook to Truss using a 1/4" Lag Screw Screws through Center Hole.
2	Cable Travel

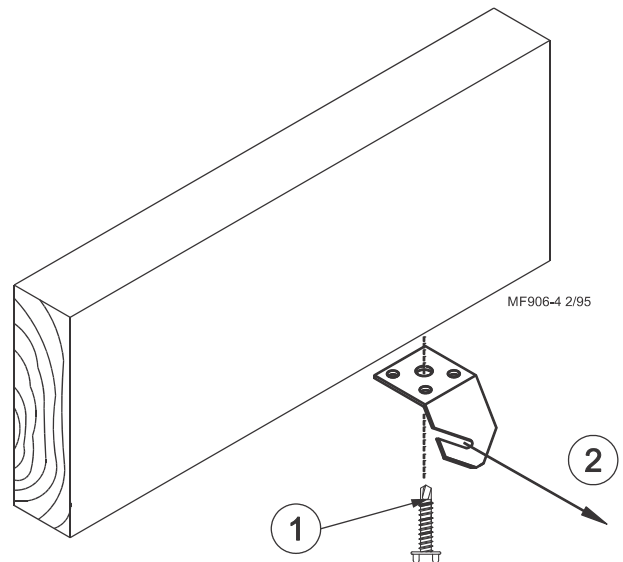

Figure 16. Wide Steel Ceiling Hook

Wood Truss Installation

Item	Description
1	Wood Truss
2	Ceiling Bracket
3	1/4" Lag Screw
4	Swivel Pulley
5	3/32" Drop Cable

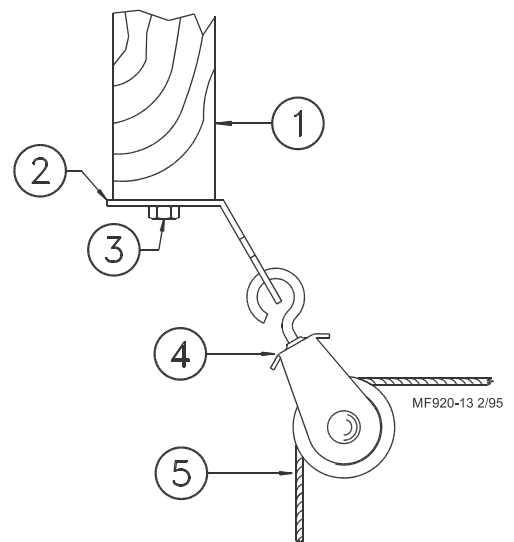

Figure 17. Ceiling Pulley Installation

Suspension Drop Line Installation

1. Attach a Pulley (3004) to each hook.
2. Thread the end of the 3/32" or 1/8" cable through the pulley toward the winch. Clamp this end to the 3/16" winch cable about 6" (150 mm) from the pulley, using a 3/16 inch cable clamp (See **Figure 12.**). Allow enough drop cable to reach the eye of the Hanger and thread back through Adjustment Leveler.

Sufficient cable is included to provide "throwbacks" on drops located beneath and near the winch. Detail A on **Figure 6** shows a "throwback" cable arrangement.

3. Begin installing suspension drops at the winch and proceed toward the elbows.

Keep the main cable tight between drops. Hang a weight on the end of the main cable to maintain tension.

4. **Figure 18** shows proper suspension points for the elbows (feeder components shown for reference only).
5. Adequate support must be provided at the elbows to prevent sagging.

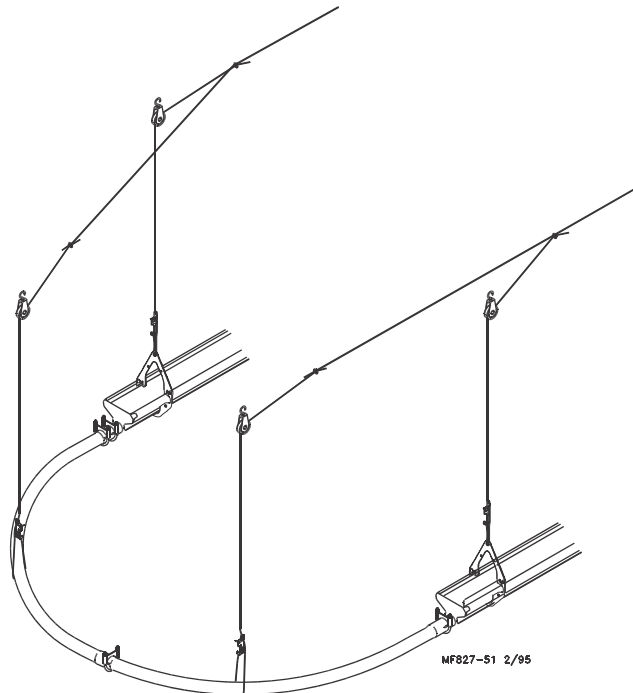

Figure 18. Supporting the Elbows

6. Three drop cables are required at each Power Unit and Hopper location.

Power Unit Locations: Three drop lines are required at each Power Unit location. Install the drop lines as specified in **Figure 19**. The Trough must be supported within approximately 1 foot (30 cm) of each Power Unit.

Feed Hopper Locations: Three drop lines are required at each Feed Hopper location. Install the drop lines as specified in. The Trough must be supported within approximately 1 foot (30 cm) of each Feed Hopper. Be sure to install the Full Line Suspension Kit, as shown in **Figure 6** (Detail C) and **Figure 19**.

IMPORTANT: Be sure to off-set the three pulleys at each Power Unit and Hopper location so that the cable clamps will not interfere with pulleys.

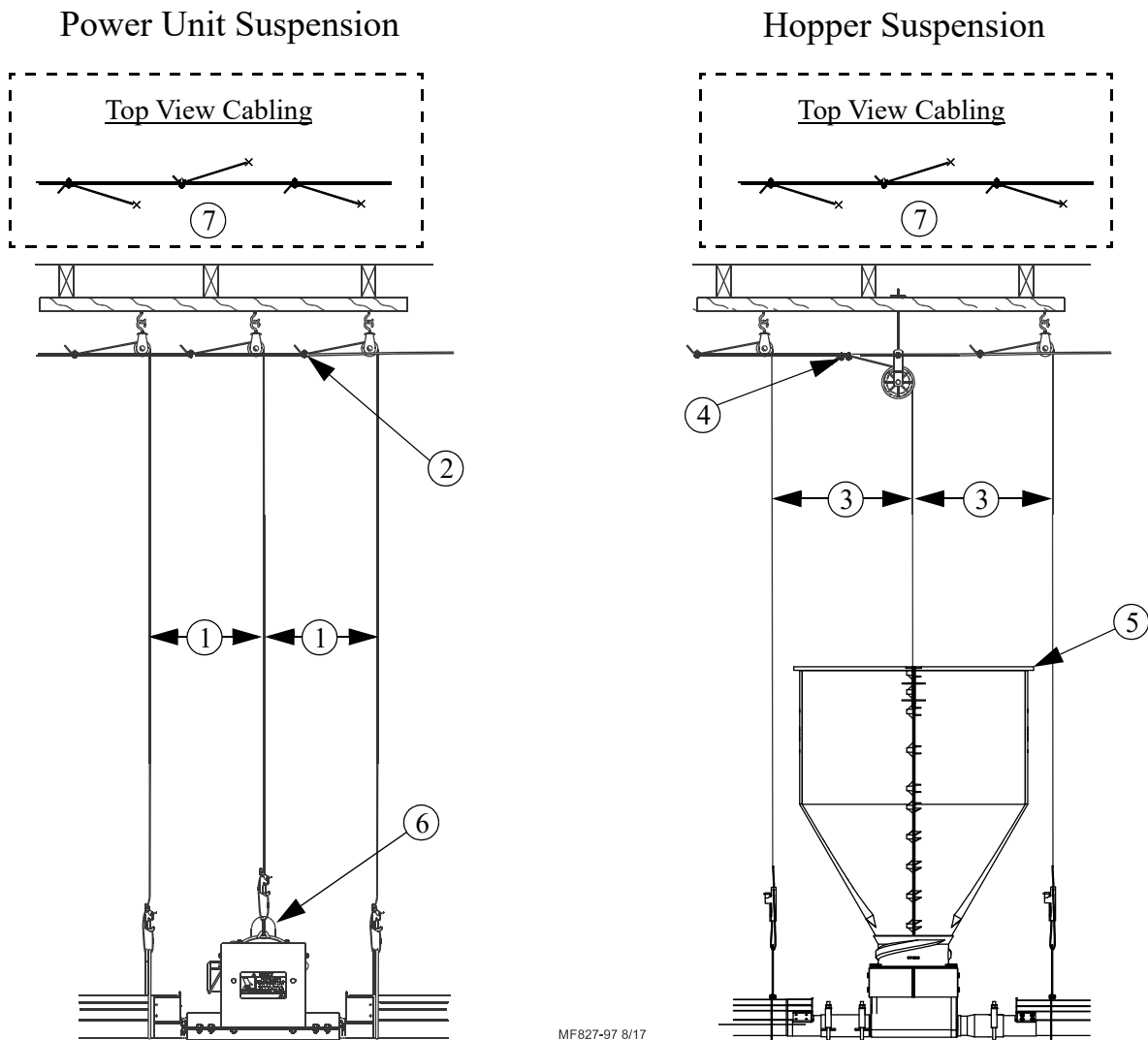

MF827-97 8/17

Item	Description
1	1' [30cm]
2	1 Cable Clamp
3	3' [1m]
4	2 Cable Clamps
5	Feed Hopper
6	Power Unit
7	Be sure to offset the Screw Hooks approximately 3" [75mm] so that the Cable Clamps do not interfere with the Pulleys.

Figure 19. Proper Suspension Points at Power Units

ULTRAFLO® Breeder Feeder Line Components Installation

The following will provide guidelines for the installation, beginning at either hopper location and proceeding in the direction of auger travel.

1. Measure and mark the trough so that when it is installed, the joint with the next trough will be located directly below a suspension drop line.
2. **Figure 20** shows hopper locations and direction of Auger travel.

Trough Hanger Installation

Install the Trough Hangers as shown but **do not** suspend the system at this time.

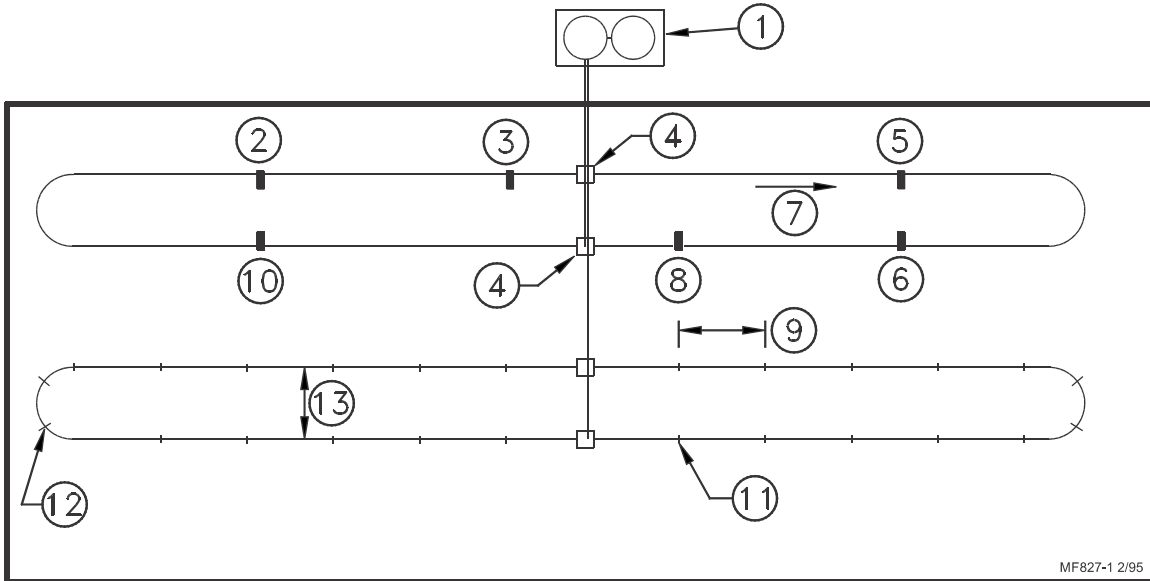

Item	Description	
1	Weigh Bin and Scales	--
2	Power Unit	--
3	Power Unit	--
4	Feed Hopper (Intake Boot)	--
5	Power Unit	--
6	Power Unit	--
7	Auger Travel	--
8	Power Unit	--
9	8' [2.4m] centers recommended. 10' [3m] centers max.	--
10	Power Unit	--
11	Suspension Drop Line	--
12	Provide adequate support to prevent elbow sagging.	--
13	5' [1.5m]	--
14	Trough	14159-3
15	Hanger Bracket Top	40202
16	Hanger Bracket Bottom	40201
17	10-24 x .50 Screw	4416-3
18	#10-24 Lock Nut	34019
19	Cable Lock	14377

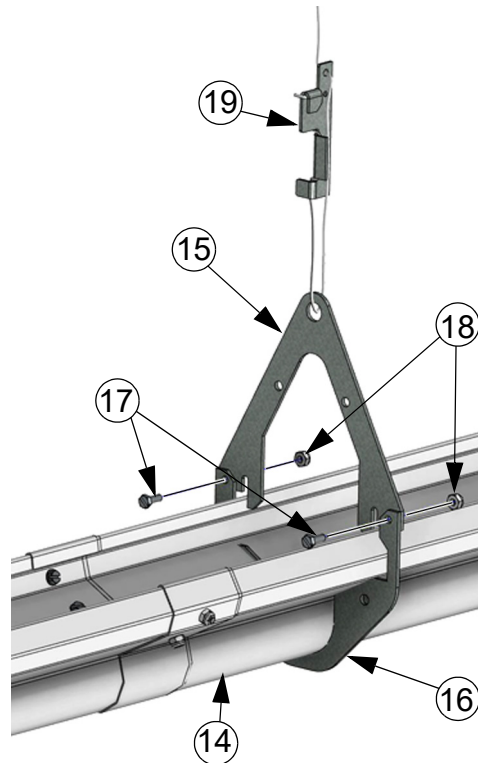
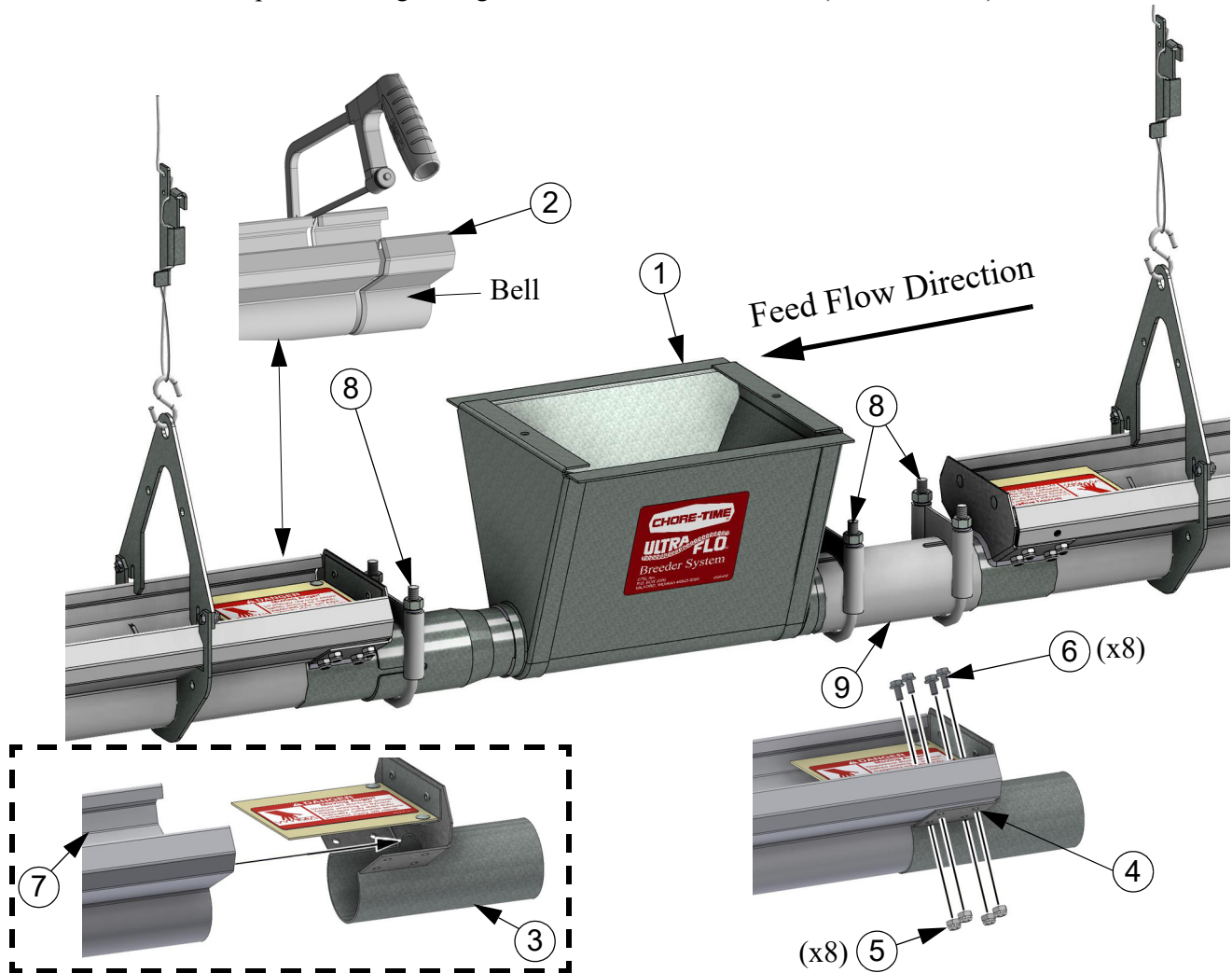

Figure 20. Breeder Feeder Line Components Installation

Intake Boot Installation

1. Determine the location of the Intake Boots. Do not install the Hoppers on the Intake Boots at this time.
2. Lay the trough sections out in the approximate position where they will be suspended, with the belled end toward the Intake Boot(s) on the outgoing side.
3. Cut the belled end off the first section of trough on the outgoing side of the Intake Boot **as shown**. The trough must be cut squarely.
4. Slide an End Cap over the end of the trough, as shown in **Figure 21**. Use the holes in the End Cap Flanges as a drilling guide to drill (4) 1/4 inch (6.3 mm) holes in each side of the trough.
5. Secure the End Cap to the Trough using 10-24 Screws and Lock Nuts (**Items 5 and 6**).



Item	Qty.	Description	Part No
1	1	Intake Boot	35580
2	--	Squarely cut the belled end off as shown	--
3	1	End Cap Assembly	25169
4	8	Drill 1/4 inch (6.3 mm) holes in each side of the trough	--
5	8	10-24 Nylon Insert Hx Nut	34019
6	8	10-24 x .375 Screw	25124
7	1	ULTRAFLO® Trough w/bell removed	14159-3
8	2	Tube Clamp	29775
9	1	Tube Connector	29691

Figure 21. Intake Boot Installation

Connecting Trough Sections together

1. Install a Hanger at the next trough joint. Slide the straight end of the trough into the belled end of another section of trough, as shown in **Figure 22**.
2. The trough sections are factory punched for (4) 10-24 bolts and locking nuts (**Items 2 and 3**).

IMPORTANT: Make sure trough is properly butted at each joint, prior to tightening hardware. To insure proper trough assembly, set the trough sections on a flat surface when tightening hardware.

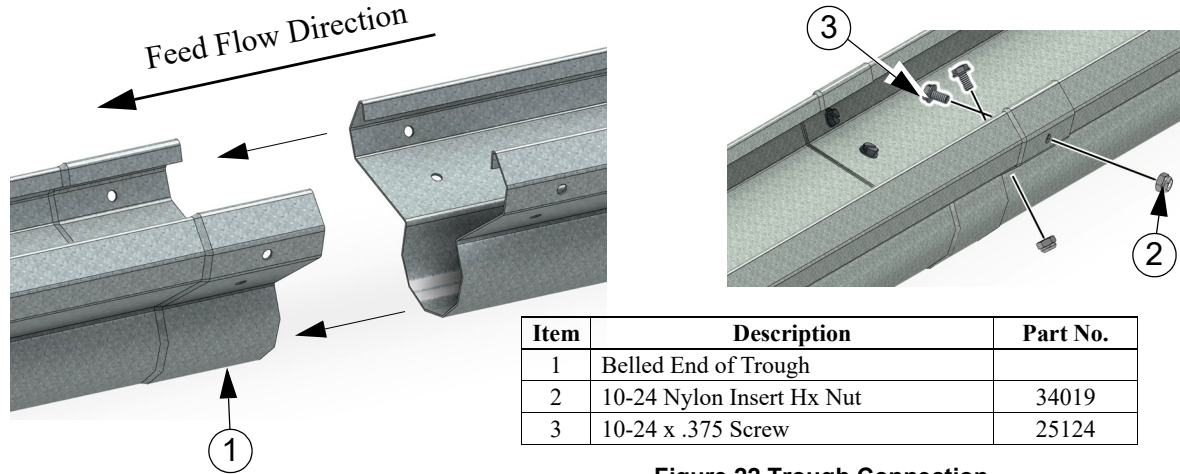

Item	Description	Part No.
1	Belled End of Trough	
2	10-24 Nylon Insert Hx Nut	34019
3	10-24 x .375 Screw	25124

Figure 22. Trough Connection

Power Unit Base Installation

1. The power units must be located directly under a suspension drop.
2. The Power Unit, Driver Assembly, and Base Connector are shipped assembled. Disassemble the Base Connector from the Power Unit and Driver Assembly by removing the four 1/4-20 locknuts. (**See Figure 23.**) Leave the Wear Shoe (**Item 2**) in place.
3. Install the End Caps and Hangers on the Trough ends **See Figure 21 (on page 21)**. Two Hangers should be used **as shown**.
4. Slide the End Caps into the End Connector Clamps on the Base Connector Weldment. Make sure the Base Connector Weldment is aligned prior to tightening the clamps.

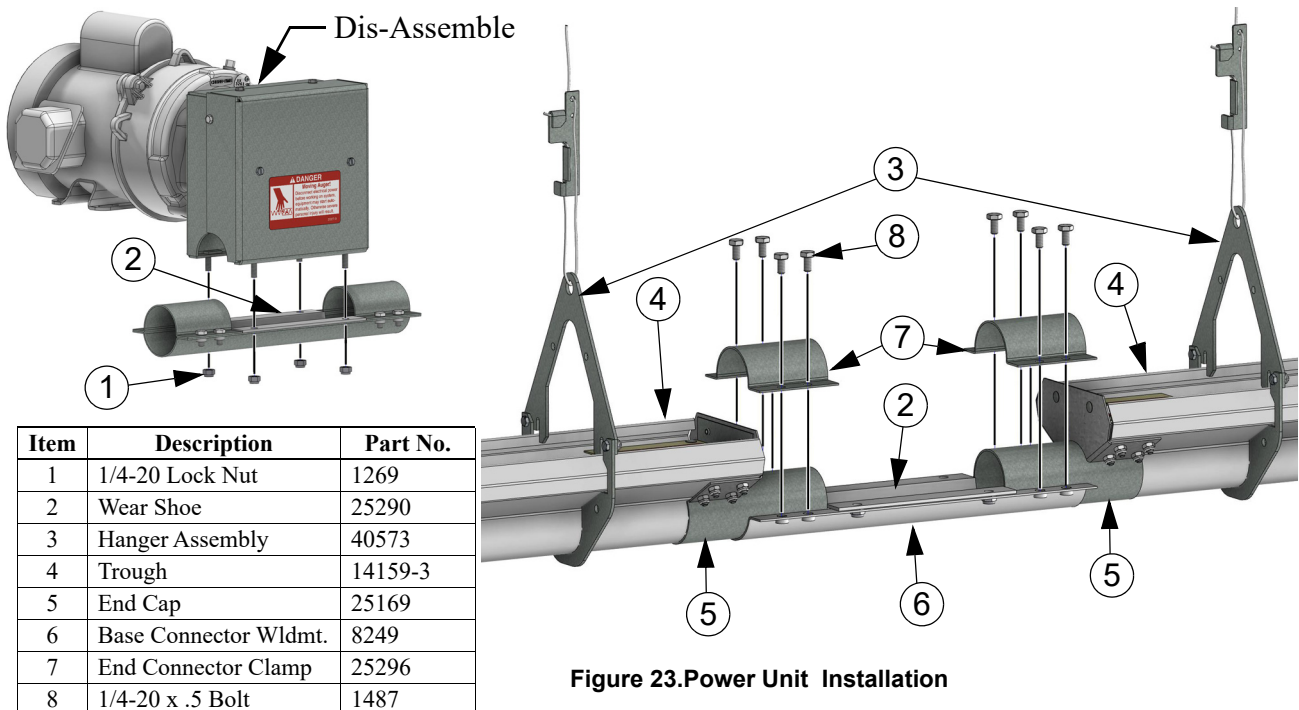

Item	Description	Part No.
1	1/4-20 Lock Nut	1269
2	Wear Shoe	25290
3	Hanger Assembly	40573
4	Trough	14159-3
5	End Cap	25169
6	Base Connector Wldmt.	8249
7	End Connector Clamp	25296
8	1/4-20 x .5 Bolt	1487

Figure 23. Power Unit Installation

5. Continue installing Trough Sections and Hangers until the first elbow is reached. It may be necessary to cut a section of trough to achieve the desired elbow location.

6. Install an End Cap on the last section of trough.

Clean Out Installation

Chore-Time offers (2) styles of Clean-Outs for use on ULTRAFLO® Breeder Feeders.

A Clean-Out should be installed on the in-coming side of the elbows. This allows the feed to be removed from the trough without running it through the elbows.

Standard Clean-Out

1. Use a 1-1/2" (40 mm) hole saw to drill a hole in the bottom of the trough as shown in **Figure 24**
2. Install a Clean-Out Cover over the hole and secure in place using 10-24 hardware supplied in the Clean-Out Cover Kit. Additional Clean-Out Kits may be ordered, separately, if necessary.
3. Install a Hanger on the incoming end of the elbow.

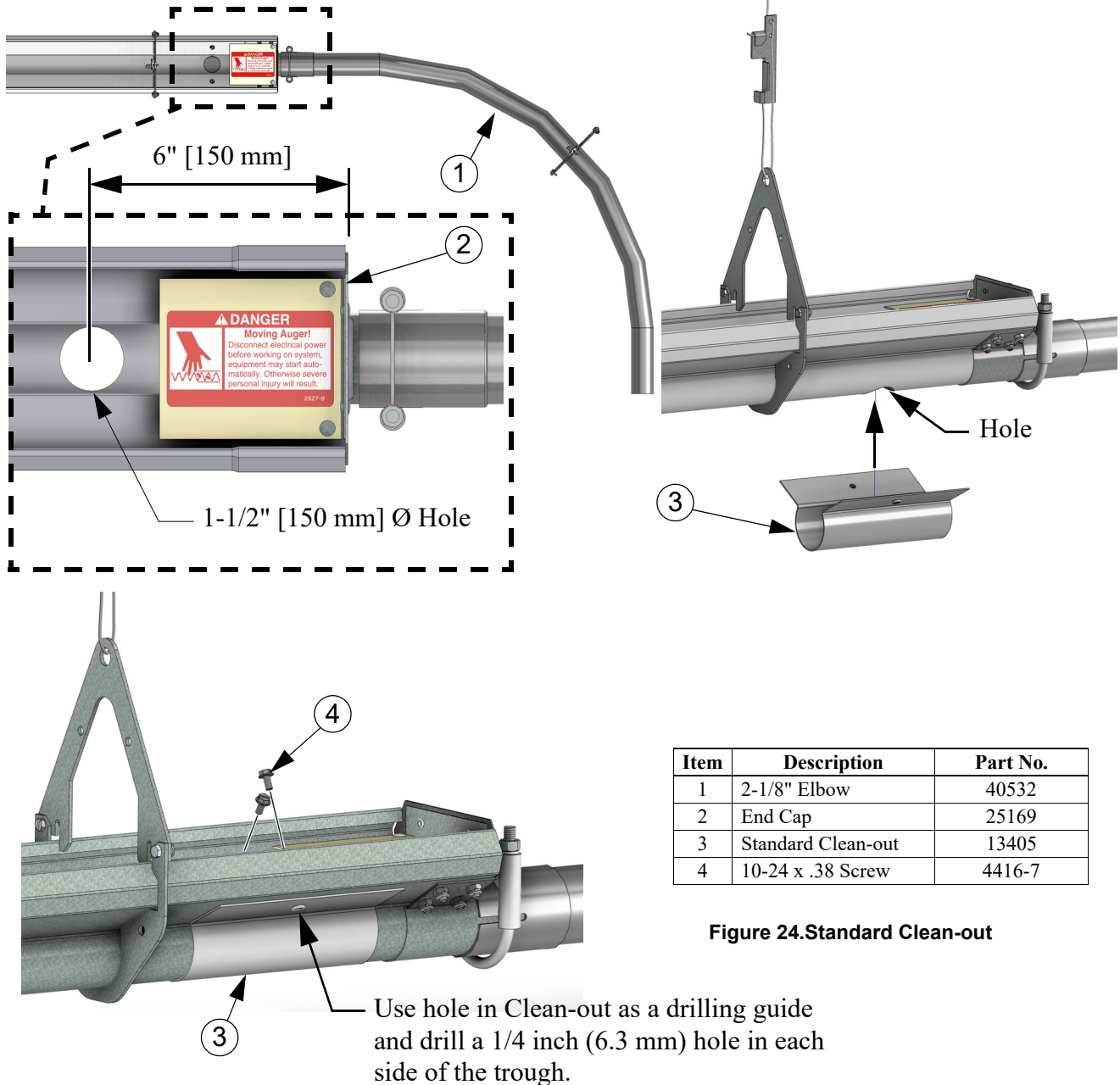

Item	Description	Part No.
1	2-1/8" Elbow	40532
2	End Cap	25169
3	Standard Clean-out	13405
4	10-24 x .38 Screw	4416-7

Figure 24. Standard Clean-out

Optional Style Clean-Out (35875 Kit)

The Optional Style clean-out should be used just prior to the Boot.

1. Install the Clean-out as shown in **Figure 25**. Remove the Nuts from the Tube Clamp closest to the Clean-out and Install the Clean-out Lock (**Item 5**) using the Wing Nuts (**Item 6**) included.
2. To operate the Clean-out, loosen the Wing Nuts, slide the Lock to allow the Clean-out to rotate down.

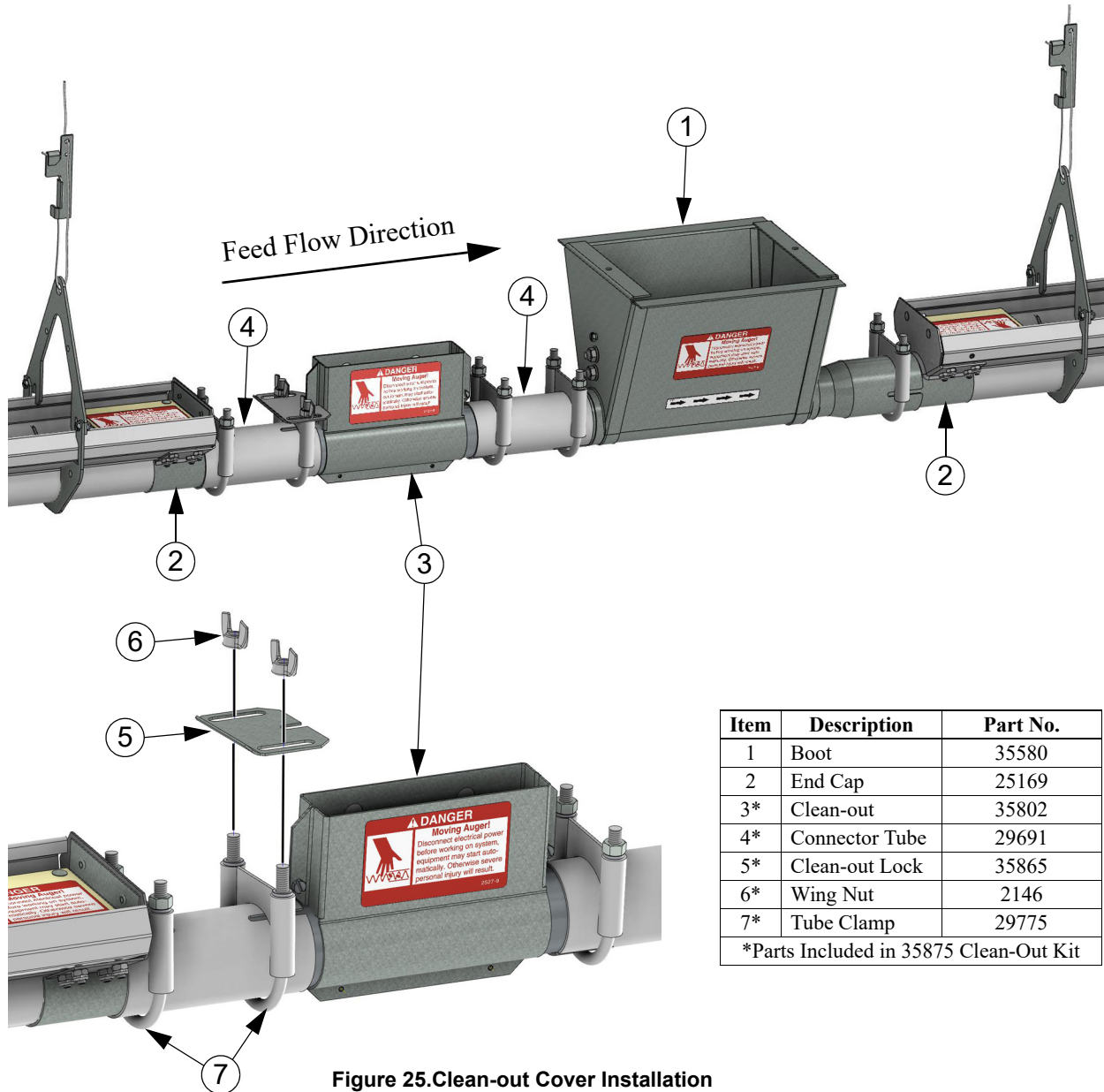

Item	Description	Part No.
1	Boot	35580
2	End Cap	25169
3*	Clean-out	35802
4*	Connector Tube	29691
5*	Clean-out Lock	35865
6*	Wing Nut	2146
7*	Tube Clamp	29775
*Parts Included in 35875 Clean-Out Kit		

Figure 25. Clean-out Cover Installation

Elbow Installation

Commercial Layer Application

1. Insert the tube section of the End Cap into the belled end of a 90 degree elbow, as shown in **Figure 26** Use a U-bolt style clamp to secure this joint...however, do not fully tighten clamp until the elbows are fully installed and leveled.
2. Loosely fasten another 90 degree elbow to the first by sliding the belled end over the straight end of the existing elbow.
3. Cut the belled end off the next section of trough. It may be necessary to cut additional length off this section of trough (for joint alignment purposes).
4. Install an End Cap on the cut end of the trough.
5. Fasten the End Cap and trough to the second 90 degree elbow, using a coupler and (2) U-bolt style clamps to secure this joint. However, do not fully tighten clamps until the elbows are fully installed and leveled.
6. Install a Hanger on the outgoing end of the trough, as shown.
7. Install the remainder of the trough, power unit(s), hangers, and clean-out(s) similar to the first.
8. Do not install the elbows on one end of the loop (to allow for auger installation).

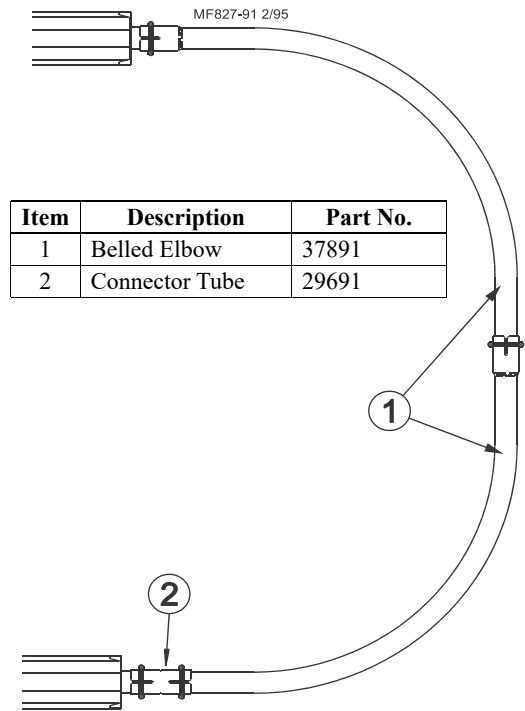

Figure 26. Commercial Layer Elbows

Broiler Breeder Application

Elbows and necessary Parts included in 48355 Elbow Loop Kit.

1. Assemble Elbows as shown using Elbow Adapters (**Item 3**) and 1/4-20 Hardware as shown.
2. Attach An Elbow to the outlet of the End Cap (**Item 1**) with a Hose Clamp (**Item 4**). Do not fully tighten clamp until the elbows are fully installed and leveled.
3. Connect Elbows together using Elbow Adapters (**Item 3**), Connecting Tube (**Item 5**), and Hose Clamps. Do not fully tighten clamps until the elbows are fully installed and leveled.
4. Install a Hanger on the outgoing end of the trough, as shown.
5. Install the remainder of the trough, power unit(s), hangers, and clean-out(s) similar to the first.
6. Do not install the elbows on one end of the loop (to allow for auger installation).

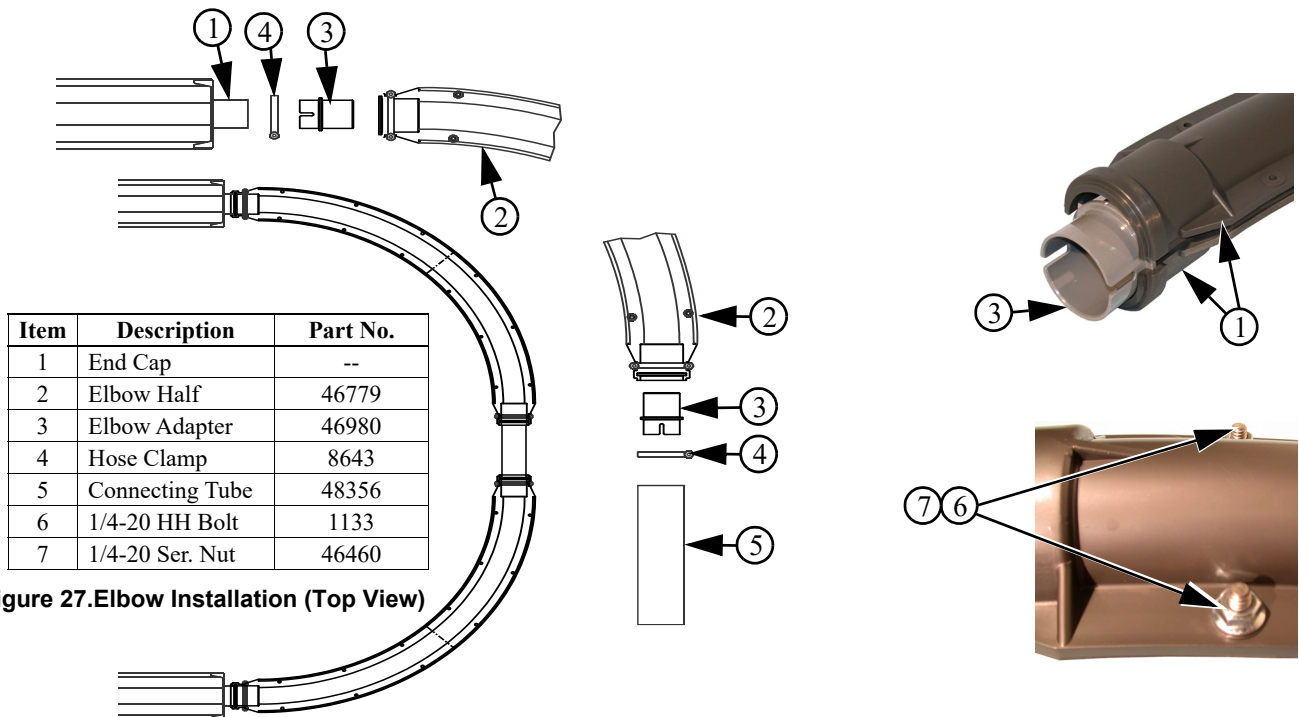

Figure 27. Elbow Installation (Top View)

Auger Installation



Use extreme caution when working with the Auger. The Auger is under tension and may spring causing personal injury. Wear protective clothing, gloves, and safety glasses when working with the Auger.

To avoid kinking the Auger, be careful not to drop or drag the rolled Auger when handling. Inspect the Auger carefully as it is installed. Small kinks may be straightened. Large kinks must be cut out and the Auger connected or brazed back together.



Prepare for the Auger Installation.

1. Install two elbows, turned out 180 degrees, this will give a convenient entrance for the ULTRAFLO[®] Breeder Feeder Augers.
The sprockets inside the Intake Boots DO NOT need to be removed.
The Power Units must be removed to allow the Auger to be installed. DO NOT USE THE MOTORS TO PULL THE AUGER INTO THE TROUGH. SERIOUS INJURY MAY OCCUR.
2. Begin feeding one end of auger into the trough through one elbow until it reaches the far end. Use a 1" X 2" board (25 X 50 mm) or something similar to push the auger through the trough. DO NOT ATTEMPT TO DRAG THE AUGER BY HAND OR PERSONAL INJURY WILL OCCUR.
3. Feed the second auger in the other elbow until it reaches the first auger.
When using two or more coils of auger, be sure to feed the auger into the trough the same for both coils. This will insure a tight match of the auger flightings when connected or brazed. Chore-Time paints the leading end of each coil of auger. The painted end of each auger should match up with the unpainted end of another auger.
4. Cut off any damaged portion of the auger, leaving a good representative end of auger.
5. Connect (or braise) the augers together at the far end of the house. Chore-Time recommends using an Auger Connector to connect the auger ends.
Note: The Auger Connector is designed to fasten the ends of ULTRAFLO[®] Auger together without welding. It is not to be used with FLEX-AUGER auger.
An alternate auger connection method, brazing, may be used in place of Auger Connectors. See “**Auger Brazing**” on page 27.
6. Screw the Auger Connector into one end of the auger. Remember: If there is any noticeable layover in auger flighting, match the ends of the auger so they lay flat against each other.
7. Untwist the end of the other auger 1-1/2 turns so that when it is threaded onto the Auger Connector it will return to it's relaxed position. The auger ends must be overlapped--NOT butted, when threaded into the track of the Auger Connector.
8. The end of each Auger should be even with one end of the Auger Connector (center the Auger Connector in the joint), as shown in **Figure 28**.
9. Tighten each set screw until it touches the auger, then tighten an additional **1/4 turn MAXIMUM**. **BE CAREFUL NOT TO OVER TIGHTEN THE SETSCREWS AND DEFORM THE AUGER. OVER TIGHTENING THE SETSCREWS MAY CAUSE THE AUGER TO JAM UP IN THE POWER UNITS.**

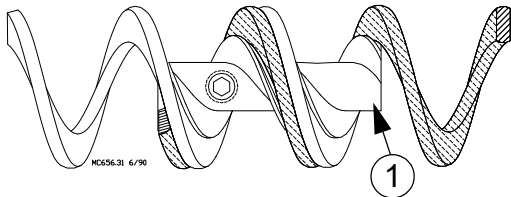

Item	Description
1	Thread the Auger Connector into the ends of the Auger

Figure 28. Auger Connector (Top View)

10. File both ends of the auger so they are the same diameter as the rest of the auger.
11. Cut any excessive auger off the coils, leaving a good representative end of auger. Allow enough auger to reinstall the disassembled elbows. Reassemble the elbows with the auger seam in the trough for easy access.
12. Pull the auger a few times to allow it to relax to its free length.
13. Determine the amount of stretch required.
Stretch the Breeder Feeder Auger 6" per 100' (150 mm per 30 m) of ACTUAL auger length.
For example: If the system has an ACTUAL length of 300' (91.4 m) of auger, the required auger stretch is 18" (460 mm).
14. Repeat **steps 5 through 10** above.

Auger Brazing

The methods for brazing FLEX-AUGER augers and ULTRAFLO[®] augers are DIFFERENT. Follow these instructions to obtain a strong joint.

1. Loosely, install the auger ends in the Brazing Clamp, as shown in **Figure 29**

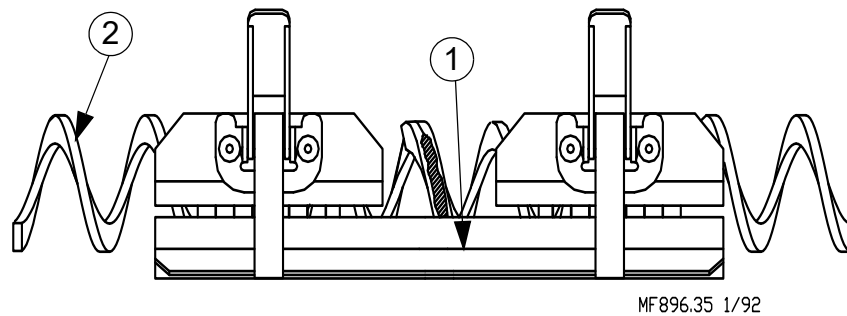

MF896.35 1/92

Item	Description
1	Brazing Clamp
2	Auger

Figure 29. Bracing the Auger for Brazing

2. Screw the auger together about 120 degrees and clamp in the Welding Fixture. (See **Figure 30.**)
3. Slowly heat the Auger and apply a braze to the inside of the Auger. Allow it to cool slightly, then rotate the Welding Fixture and braze the outside of the Auger. The braze should extend from 1/8" to 1/4" (3 to 6 mm) from the end of each Auger.

DO NOT BRAZE ALL THE WAY TO THE END. This allows the Auger to flex in either direction as it travels around the elbows without becoming weakened.

Things to remember when brazing the Auger . . .

1. To insure a good braze, clean dirt, oil, etc., off both ends of the auger.
2. A bronze, flux coated filler rod is recommended.
3. The joint should be smooth and well filled.
4. Do not over heat the auger; apply just enough heat to melt the filler rod.
5. Allow the auger to air cool.
6. File all edges smooth.
7. The outside diameter of the braze should not be larger than the rest of the auger.

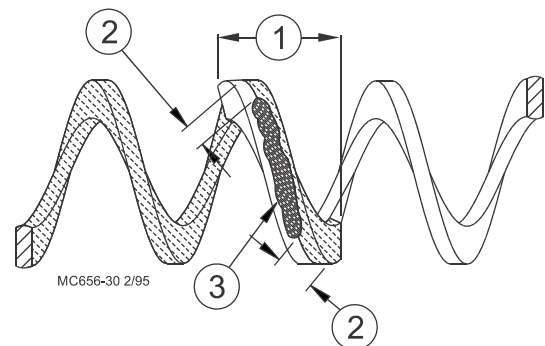

MC656-30 2/95

Item	Description
1	1/3 Turn
2	1/8" to 1/4" [3 to 6mm]
3	Weld

Figure 30. Brazing the Auger

Power Unit Installation

1. Secure the Power Unit and Driver Assembly to the Base Connector, using 1/4-20 locknuts, previously removed. (See Figure 31.)

Each Power Unit location requires (3) suspension drop lines to support the Power Unit and prevent sagging. If the Power Unit Litter Shields are not going to be used, support the motor as shown in Figure 31. For installations using Power Unit Litter Shield, continue to step #2.

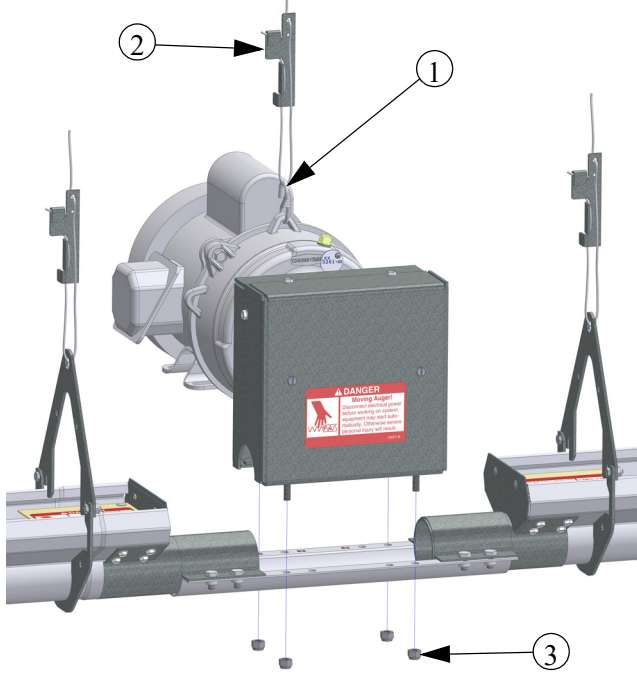

Item	Description	Part No.
1	"S" Hook	2805
2	Cable Lock	14377
3	1/4-20 Lock Nut	1269

Figure 31. Power Unit Installation

The Power Unit Litter Shield is a metal covering that helps prevent buildup on the Power Unit/Driver Assemblies. The Litter Shield also discourages roosting on the Power Units.

1. Remove the screw, from each side of the Driver Assembly (See Figure 32.)

Note: DO NOT DISCARD THESE SCREWS.

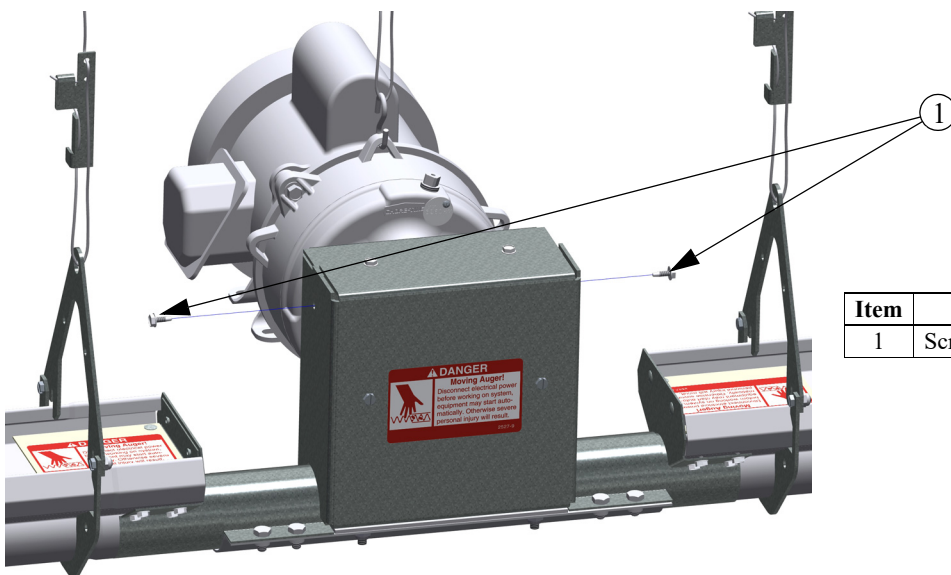

Item	Description
1	Screw (Remove but Do Not Discard)

Figure 32. Remove Screws for Litter Shield Installation

2. Using the 10-24 screws (1487) provided, loosely fasten a Motor Support (34266) to each Shield Side. (See Figure 33.). Note: The Motor Supports include weld nuts. Install the tabs so that they face opposite directions when secured to the Shield Sides.
3. Fasten Side Shields together with 1/4-20 Screws (1487) and 1/4-20 Hex Nuts (751) as shown.

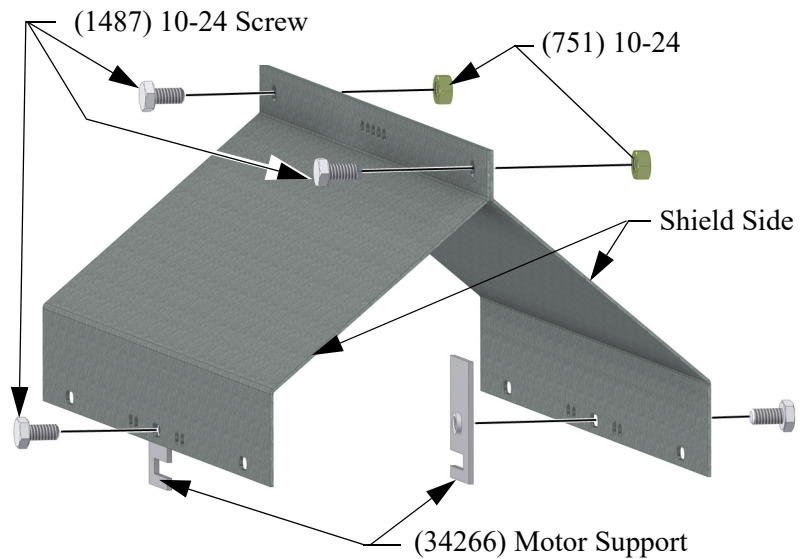

Figure 33.Litter Shield Installation

4. Assemble the Shield Sides on the Power Unit (Figure 34). The Motor Supports slip into the ears on the gearhead.
5. Secure the Litter Shield to the Driver Assembly using the screws removed in Figure 32.
6. Tighten the screws securing the Motor Supports.
7. Install the power unit suspension components as shown.

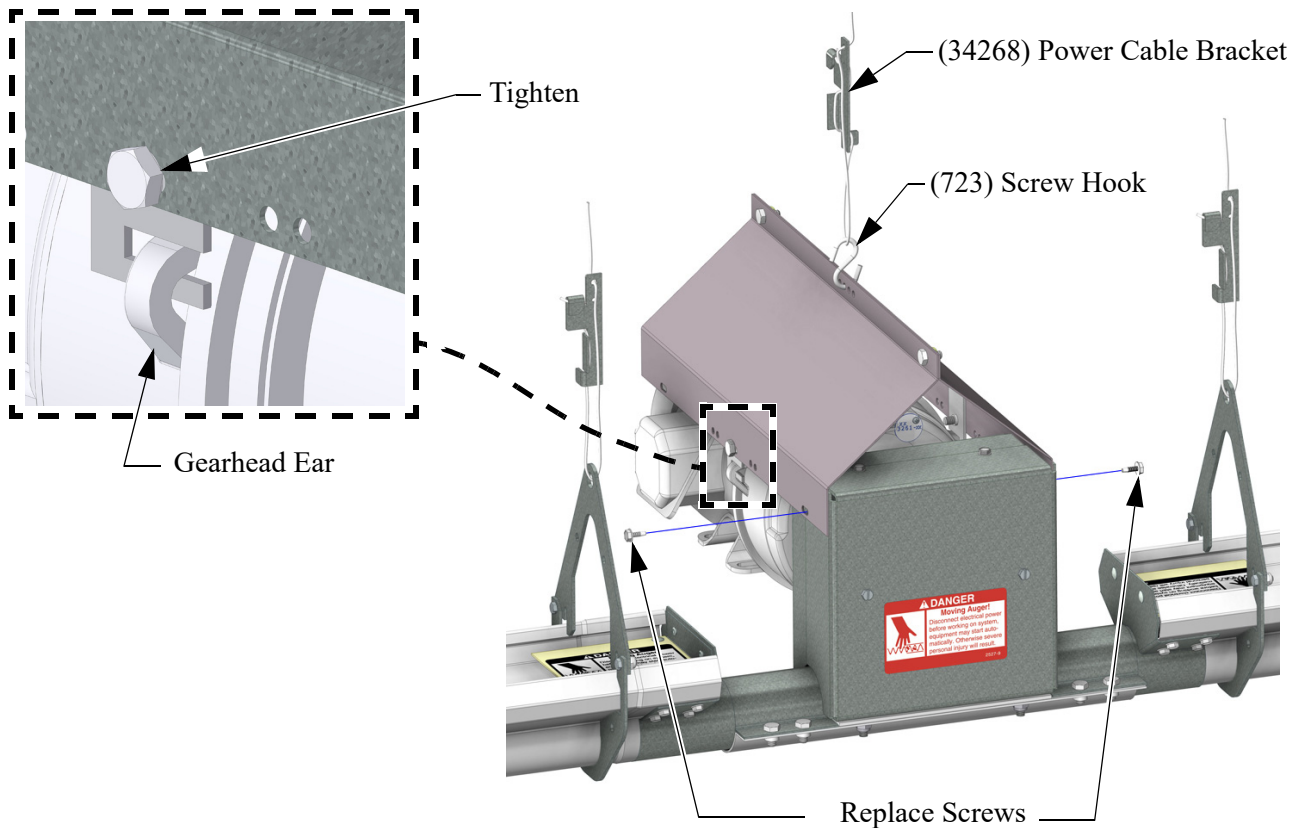

Figure 34.Litter Shield Installation

8.

Grill Installation (Standard and Hi-Contour)

The ULTRAFLO® Breeder Feeder offers the choice of (3) Grill styles, the standard Grill, standard Grill (w/ horizontal runner wire), & the Hi-Contour Grill. Refer to **Figure 35** for applicable Grill installation diagram. Additionally, a variety of spacings are available for each grill style.

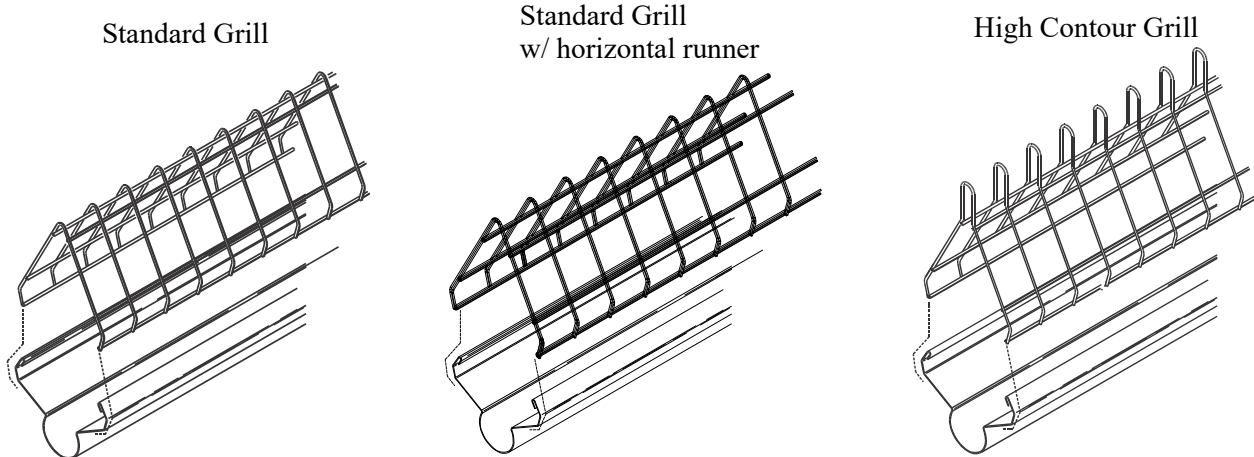

Figure 35. Grill Installation

The grills for the ULTRAFLO® Breeder Feeder are shipped in 10’ (3 m) sections to easily match the feeder trough which is also shipped in 10’ (3 m) sections. The grill seams should be located at the feeder trough seams.

The grills are formed to fit snugly against the trough when properly installed.

To install the grills, position one side of the grill over the lip of the trough. Then pull the other side of the Grill over the lip of the trough.

Begin installing the Grills at one end of the feeder line, it will be necessary to cut some of the Grills to match cut sections of trough.

Install Grill End Caps on the ends of the grills at the Power Units, Intake Boots, and Elbows. Use pliers to crimp Grill End Caps to grill wire. (See **Figure 36.**)

Standard Grill ONLY: Cut a 6" (150 mm) section of grill and install over the existing grill where the auger enters and exits the Power Units, Intake Boots, etc. This will reduce the wire spacing, making it impossible for the birds to eat near the auger entry point.

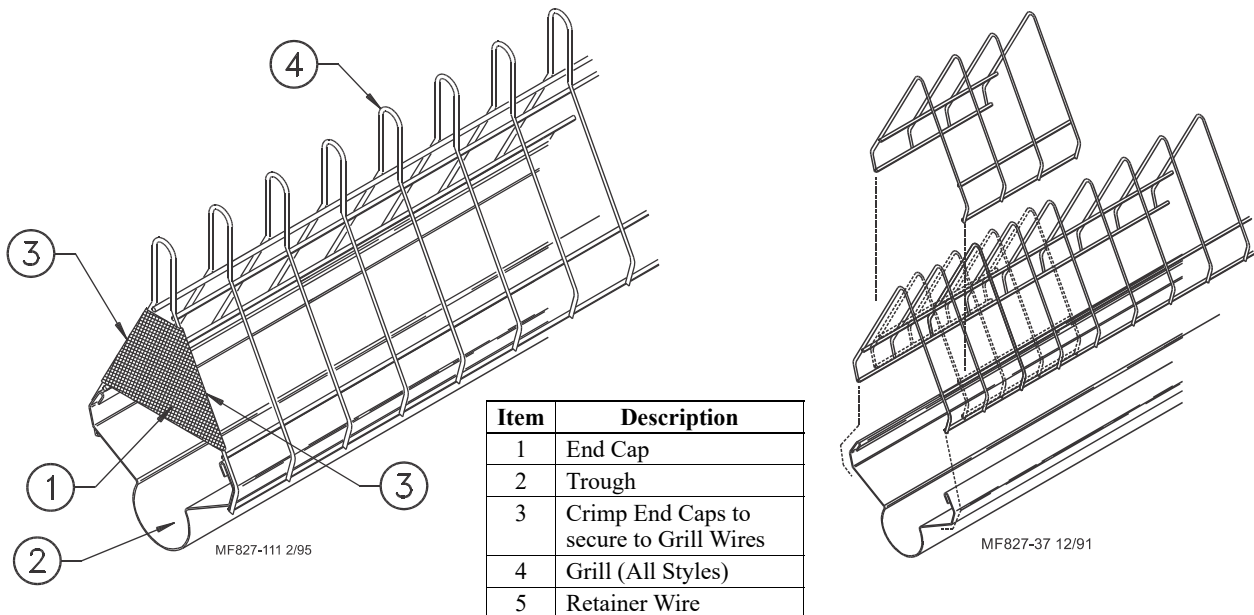
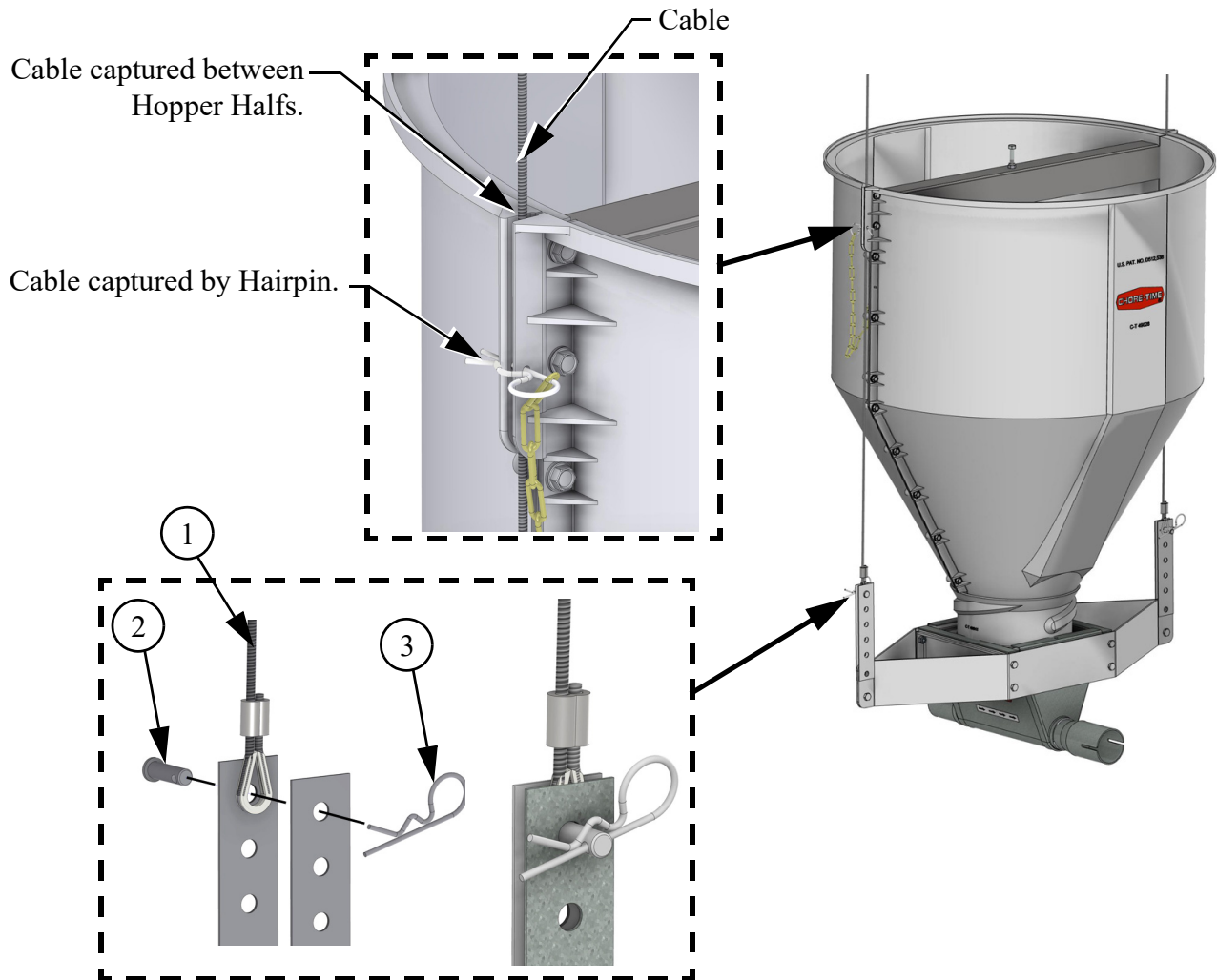

Figure 36. Litter Grill End Cap Installation

Hopper Installation

With the feeder line totally suspended, the hoppers are ready to be installed.

A Cable Assembly (included in the Hopper Suspension Kit) is supplied to suspend the hopper. **Figure 37** shows the suspension components assembled. See “150LB Plastic Hopper” on page 10 for more detailed instruction.



Item	Description
1	Cable
2	Clevis Pin
3	Hair Pin
4	Hopper Side Panel

Figure 37.Hopper Installation

Securing Hopper to Intake Boot

Secure a Twist Lock Collar (**Item 1**) to the top of each Intake Boot with 1/4-20 x .5" Bolts (**Item 2**) and 1/4-20 Nylon Nuts (**Item 3**), as shown in **Figure 38**.

Insert the Hopper into the Twist Lock Collar and twist until locked in place.

Item	Description	Part No.
1	Twist Lock Collar	49041
2	1/4-20 x .50 Bolt	1487
3	1/4-20 Nylon Insert Nut	1269
4	Boot	--
5	Hopper Assembly	--

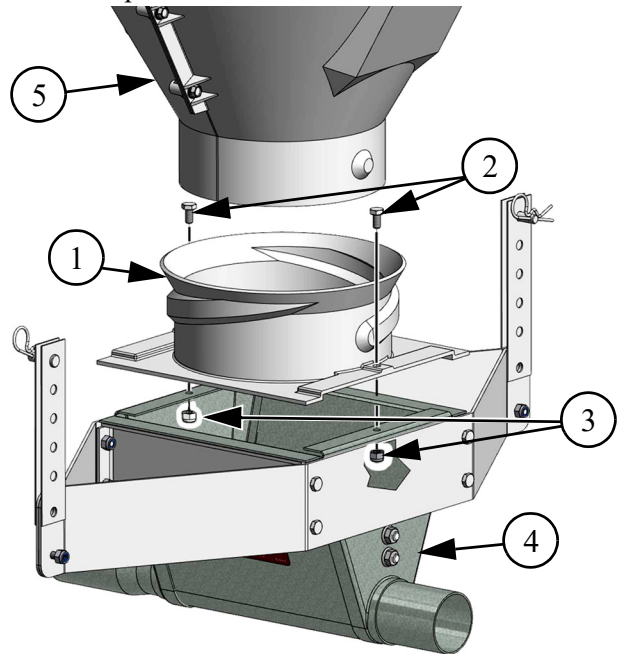

Figure 38.Securing Hopper to Intake Boot

Suspending the System

Hangers should have been installed at the time of assembly. If a Hanger was not installed where it should have been, a Hanger may be gently pulled open to fit around the trough.

Figure 39 shows the proper cable routing around an Adjustment Lever.

Use the Adjustment Leveler to adjust the trough height at each Hanger. Measure from the slats or ceiling to accurately level the system.

Item	Description	Part No.
1	Trough	14159-3
2	Hanger Bracket Top	40202
3	Hanger Bracket Bottom	40201
4	10-24 x .50 Screw	4416-3
5	#10-24 Lock Nut	34019
6	Cable Lock	14377

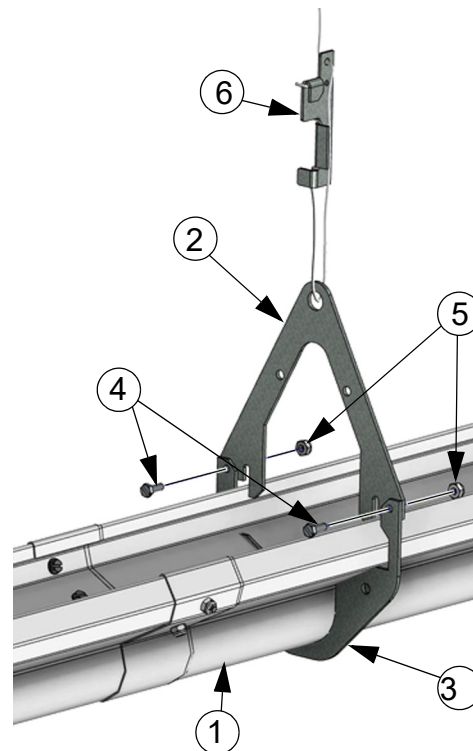
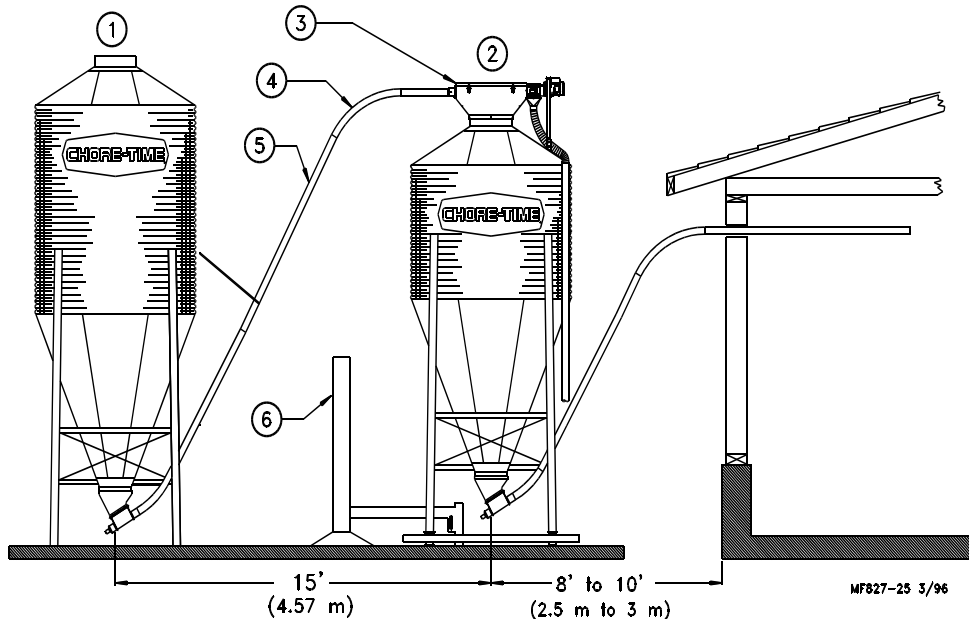

Figure 39.Trough Hanger

Installing the Fill System

Install the Fill System according to the instructions shipped with the FLEX-AUGER Control Unit (MA1000 for Model 90, MA1032 for Model 108). Fasten the Drop Tubes to the Outlet Drops and Control Unit Funnel, using the self-tapping screws supplied. It will be necessary to cut holes in the Hopper Covers for the Drop tube to enter the hoppers.

Installation of the Weigh-Matic Scales



TWO SCALES ARE AVAILABLE:

5,000 Pound (2,268 kg) Scale and 8,000 Pound (3,628 kg) Scale

If larger quantities of feed are desired, divide the total feed requirements into two or more equal feedings.

Item	Description
1	Storage Bin
2	Weigh Bin
3	Weigh-Matic Screener
4	45 Degree Elbow
5	Straight Tube
6	Weigh-Matic Scale

Figure 40. Weigh-Matic Scales

Bin Location & Scale Preparation

The ULTRAFLO Feeder requires the use of a feed scale system. Chore-Time has (2) available: the (mechanical) Weigh-Matic, shown in **Figure 40**, and the Digital Weigh-Matic. Refer to the instruction manual shipped with the Digital Weigh-Matic for installation and operation of that type of scale. Instructions for the (mechanical) Weigh-Matic are included in this manual.

For ease of installation and most trouble-free operation, the Weigh Bin should be located directly in line with the FLEX-AUGER Delivery System. Some installations may require the storage bin to be set 90 degrees to the fill system. Both types of installation are acceptable, (**See Figure 41.**)

Typically, the Weigh Bin is set 8 to 10 feet (2.4 to 3 m) from the building. This varies somewhat depending on the desired height of the FLEX-AUGER System inside the building. Two 45 degree PVC elbows and one 10 foot (3 m) PVC tube are standard with the WEIGH-MATIC Fill System. To place the bin nearer to or farther from the building, additional tubes or elbows may be required.

Refer to the Feed Bin Installation Manual for information on required concrete thickness, foundation requirements, slope maximums, etc. The surface of the concrete foundation must be level and smooth.

Item	Description
1	Fill system positioned 90 degrees to the feed bins.
2	Fill system in-line with the fill system.
3	Building

Figure 41. Weigh Matic Scales Installation

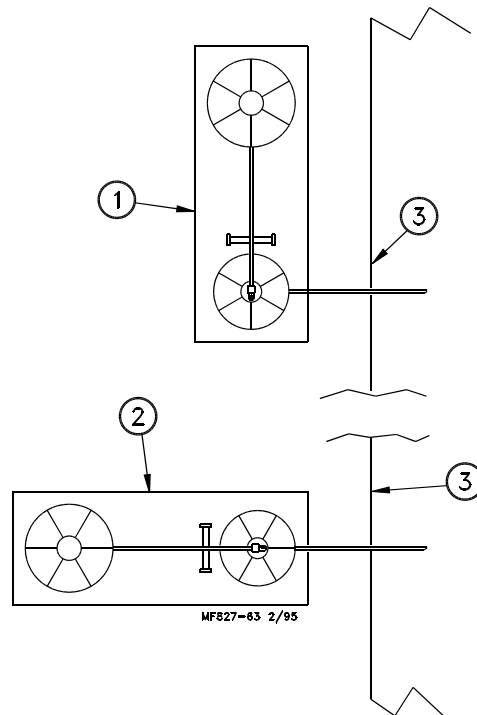

Figure 42 through **Figure 45** provide pad dimensions for 7' (2.13 m) & 9' (2.74 m) storage bins, using one pad or separate pads. Refer to the diagram that applies to your installation. The Storage Bin may be located in line with the Weigh Bin or off-set 90 degrees to one side or the other.

7' (2.13 m) Storage Bin and Weigh Bin using (2) Pads

Item	Description
1	Building
2	7' (2.13 m) Storage Bin
3	Building

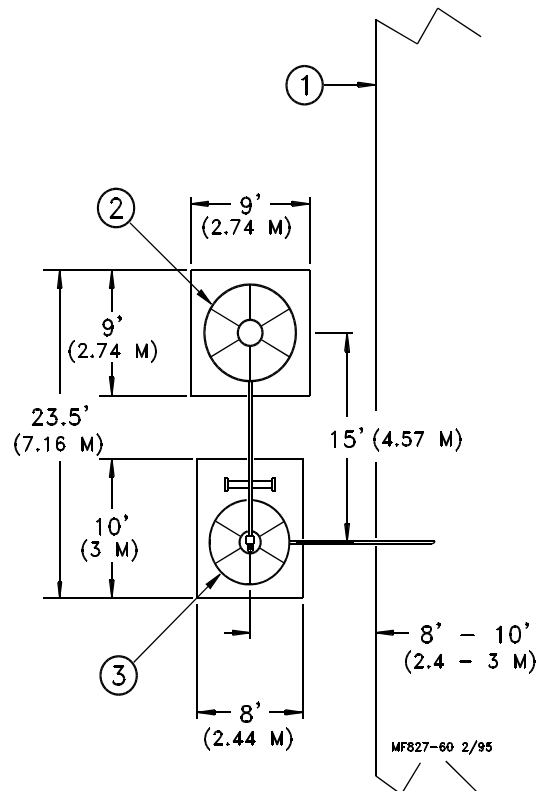

Figure 42. Bin to Bin and Bin to Building Dimensions

7' (2.13 m) Storage Bin and Weigh Bin using (1) Pad

Item	Description
1	Building
2	7' (2.13 m) Storage Bin
3	Weigh Bin

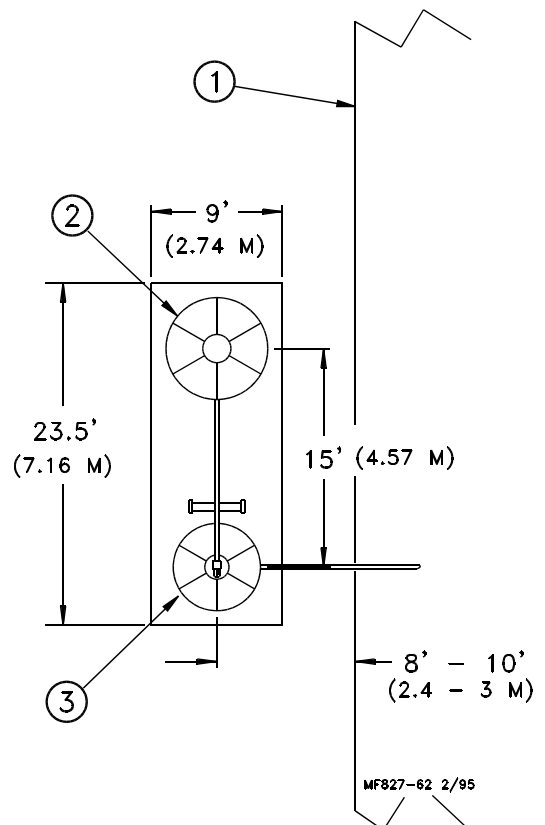
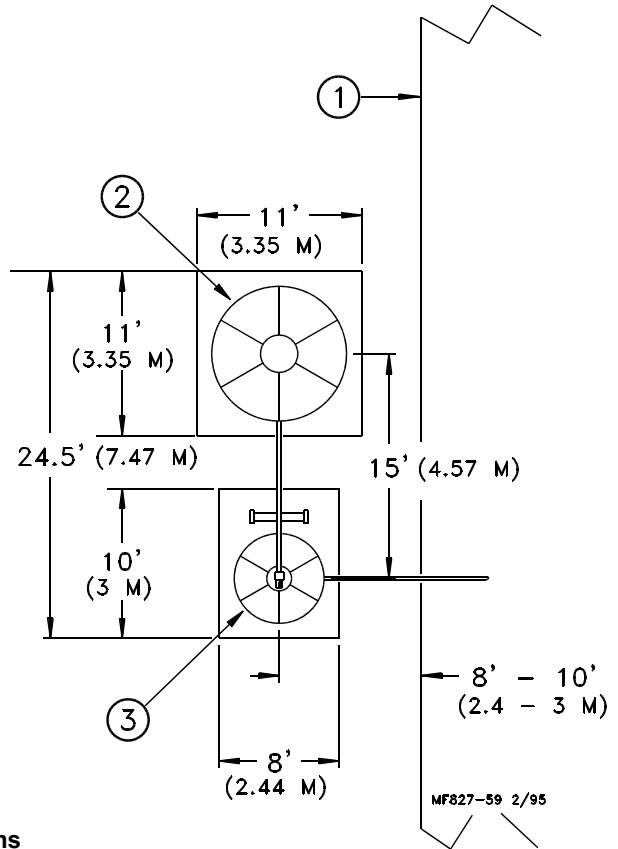

Figure 43. Bin-to-Bin and Bin-to-Building Dimensions

11' (3.35 m) Storage Bin and Weigh Bin using (2) Pad



Item	Description
1	Building
2	9' (2.74 m) Storage Bin
3	Weigh Bin

Figure 44. Bin-to-Bin and Bin-to-Building Dimensions

11' (3.35 m) Storage Bin and Weigh Bin using (1) Pad

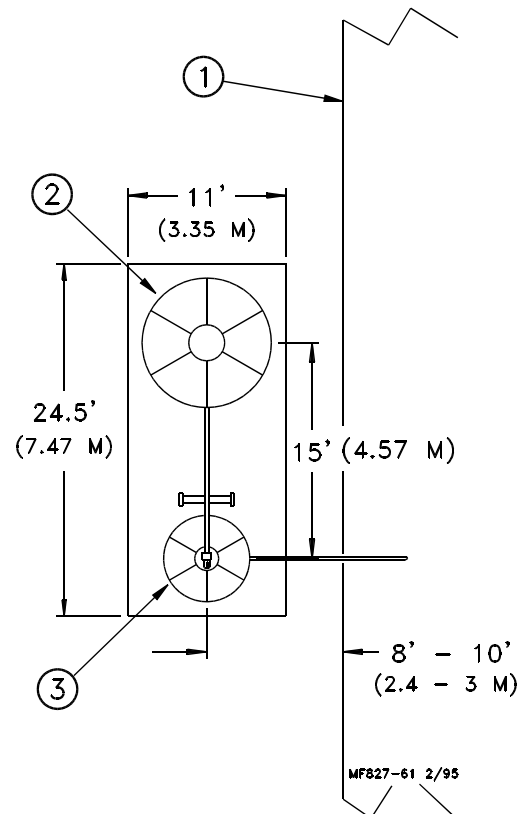

Item	Description
1	Building
2	9' (2.74 m) Storage Bin
3	Weigh Bin

Figure 45. Bin-to-Bin and Bin-to-Building Dimensions

5978 Template for Winslow Scale

Use the 5978 Scale Template, as shown in **Figure 46**, or the Anchor Bolt Setting Diagram in **Figure 47**, to locate the correct position of the 16 anchor bolts for the scale system.

Note: Chore-Time strongly recommends using the Scale Template (Part No. 5978) to determine location of Anchor Holes for the Scales and Bin.

If the 5978 Scale Template Kit is used to locate the position of the anchor holes for the Weigh-Matic Scales and Bin, refer to the instructions below.

1. Loosely assemble the template as shown, using 5/16-18 hardware supplied.
2. Use a framing square to check all corners of the template. Make sure all corners of the template are square before tightening the nuts.
3. Allow concrete to harden completely before anchor bolt holes are drilled.
Use a 1/2 inch (13 mm) carbide tipped masonry drill bit to drill the anchor holes. The holes must be at least 3 inches (75 mm) deep to install the anchor bolts.

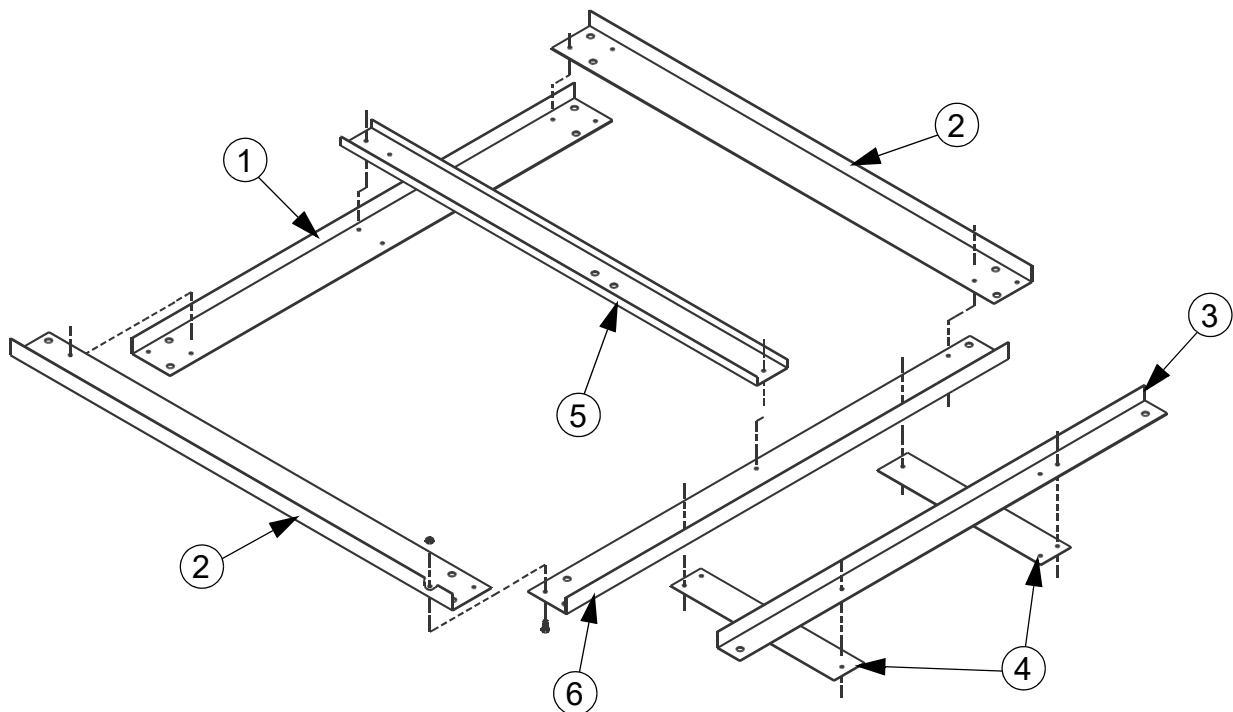

Item	Description	Part No.
1	Rear Plate	5984
2	Side Plate	5988
3	Beam Box Leg Plate	5986
4	Connector Plate	5985
5	Center Plate	5989
6	Front Plate	5987

Figure 46. Scale Template Assembly Diagram

Anchor Bolt Setting

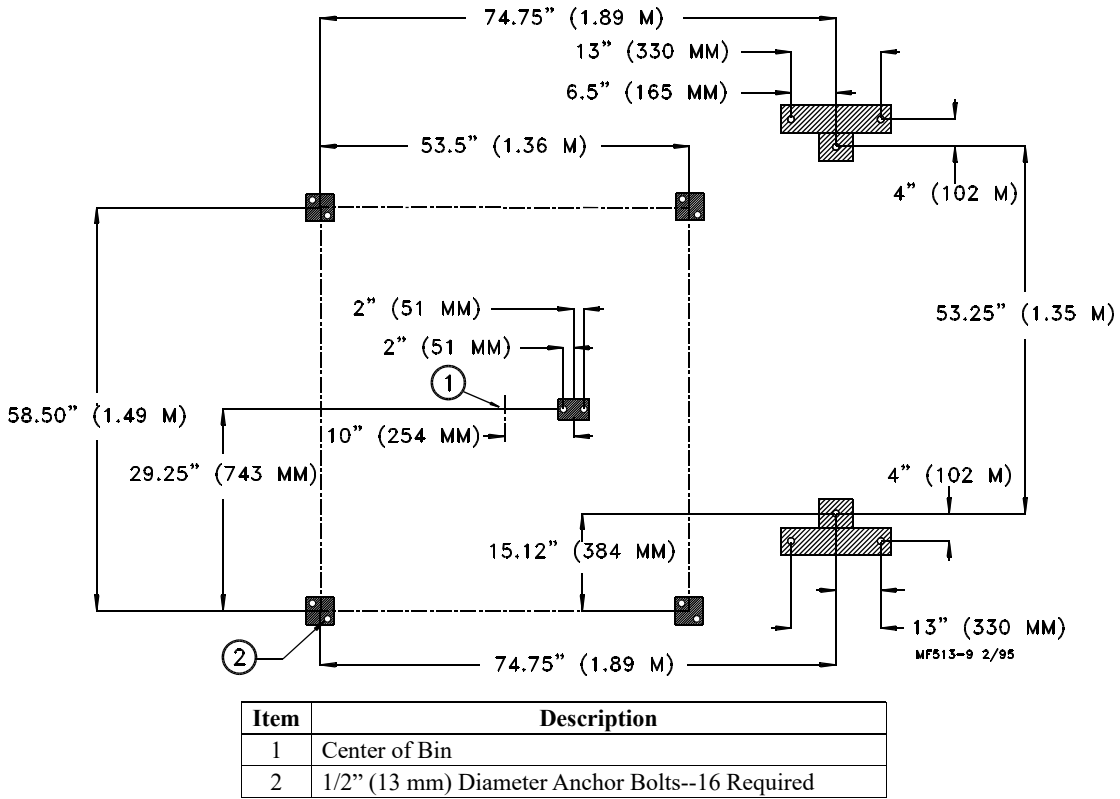
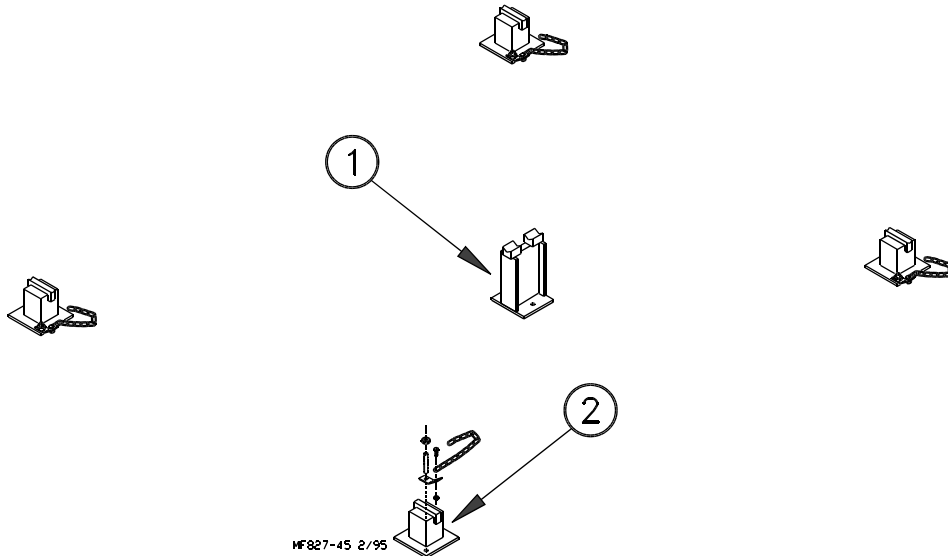

Figure 47.Anchor Bolt Setting Diagram

Scale Stand Locations

1. Place the four Lower Main Stands and the Transverse Stand over the holes drilled in the foundation. (See **Figure 48.**) for approximate placement. Install the Anchor Bolts and Safety Chain Assemblies but do not tighten the anchors until the scale levers are in position.



Item	Description
1	Transfer Stand
2	Lower Main Stand

Figure 48.Scale Stand Locations

2. Check all Scale Pivots and Bearings, including those on the weigh beam. They must be CLEAN AND FREE OF PAINT OR DIRT!
3. Attach the Legs and Leg Supports to the Beam Box. Anchor the Beam Box in place on the bin pad. (See **Figure 49.**)

Item	Description
1	Transfer Stand
2	Lower Main Stand

Figure 49. Attach Leg Supports to Scale Legs

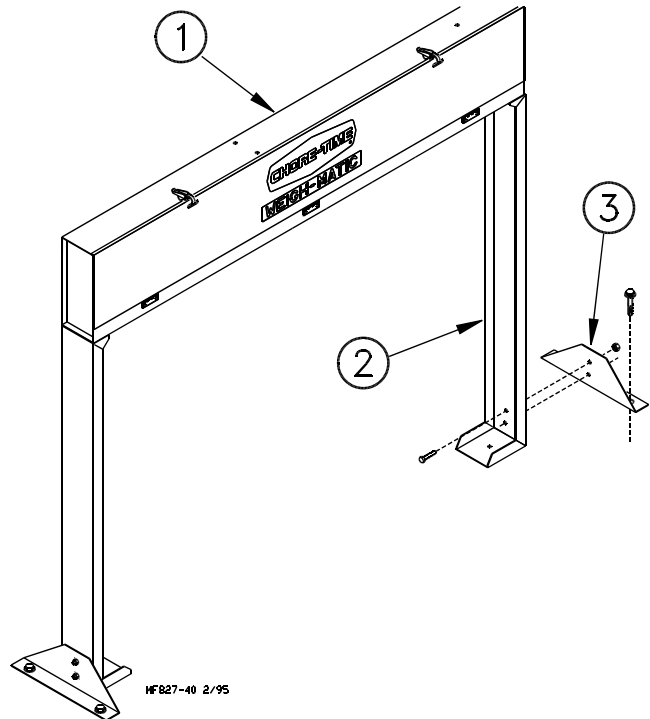

4. Mount the 5789 Magnetic Actuator on the end of the weigh beam using the two 4-40 X 3/4" Rd. Hd. Screws provided. (See **Figure 50.**)

Item	Description
1	Magnetic Actuator
2	(2) 4-40 x 3/4" Rd. Hd. Screws
3	Note: Make sure the magnet on the arm and the switch Magnet are aligned.

Figure 50. Align the Weigh-Beam in the Beam Box

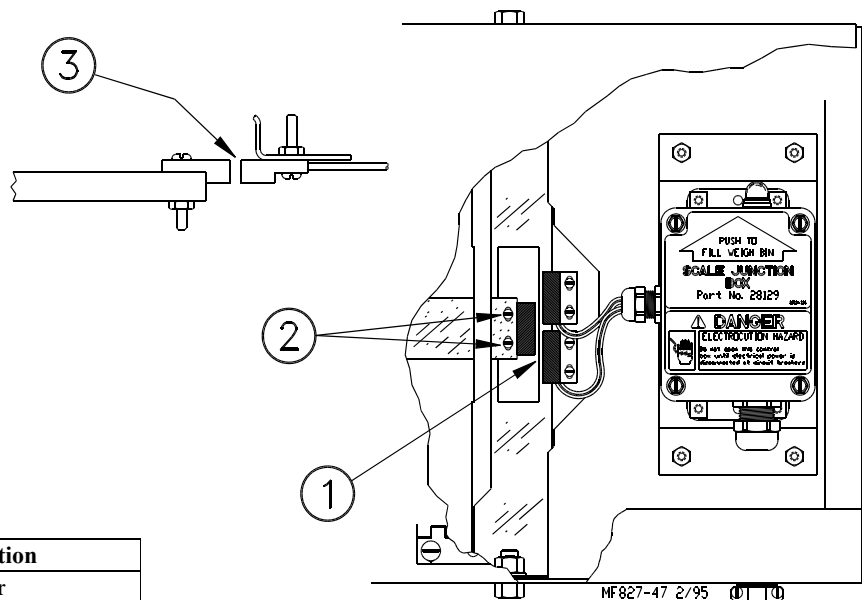

5. Install the Weigh Beam Assembly in the Beam Box. Attach the Beam Stand Assembly to the left side of the Pivot Bracket with two 1/4-20 X 5/8" Rd. Hd. Machine Screws and Hex Nuts. (See Figure 51.)
BE CAREFUL NOT TO BUMP OR DAMAGE THE MAGNETIC ACTUATOR OR THE TWO PROXIMITY SENSORS WHEN INSTALLING THE WEIGH BEAM.

Item	Description
1	Weigh Beam Assembly
2	Back Balance: The Back Balance may be installed at this time or just before the scale is to be balanced.
3	1/4-20 Hardware

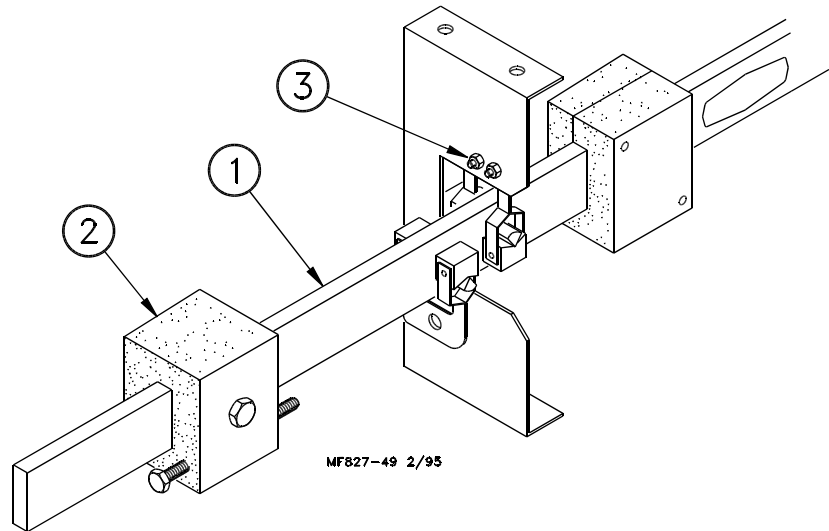
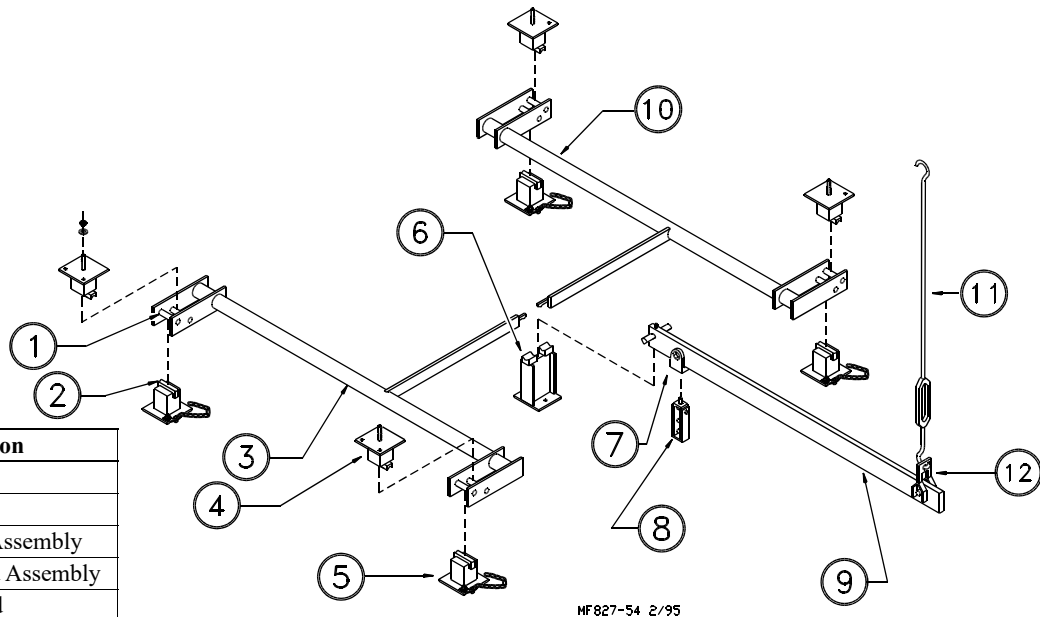

Figure 51. Weigh-Beam Installation

6. Adjust the (2) proximity sensors to give 1/8" (3.1 mm) clearance between them and the magnetic actuator on the weigh beam. The two proximity sensors should be positioned initially with 1/8" (3.1 mm) between them. These adjustments provide a starting point for balancing the scale and protect the switching components during scale assembly.
7. Attach the Shackle to the Transverse Lever. (See Figure 52.) Rest the Fulcrums on the Bearings.
8. Hook the Steelyard Rod to the Trip Loop of the Transverse Lever and connect the other end of the rod to the Loop Assembly on the weigh beam. Adjust the turnbuckle so that the Transverse Lever is level. (See Figure 52.)



Item	Description
1	Fulcrum
2	Bearing
3	Left Main Lever Assembly
4	Upper Main Stand Assembly
5	Lower Main Stand
6	Transverse Stand Assembly
7	Load Loop Shackle
8	Shackle
9	Transverse Lever Assembly
10	Right Main Lever Assembly
11	Steelyard Rod
12	Trip Loop

Figure 52. Scale Component Assembly Diagram

! IMPORTANT !

Tip Pivots should be positioned directly above one another. Shift Lower Main Stands as necessary to accomplish this.

Check Weigh Beam Assembly carefully following installation. Beam must pivot freely for proper operation of the scale.

Figure 52. Weigh-Beam Installation

9. Install the Right and Left Main Levers with their Fulcrum Pivots on the Bearings of the Lower Main Stands. The Main Lever's Tip Pivots rest directly above each other in the Shackle. (See **Figure 53** and **Figure 54**).

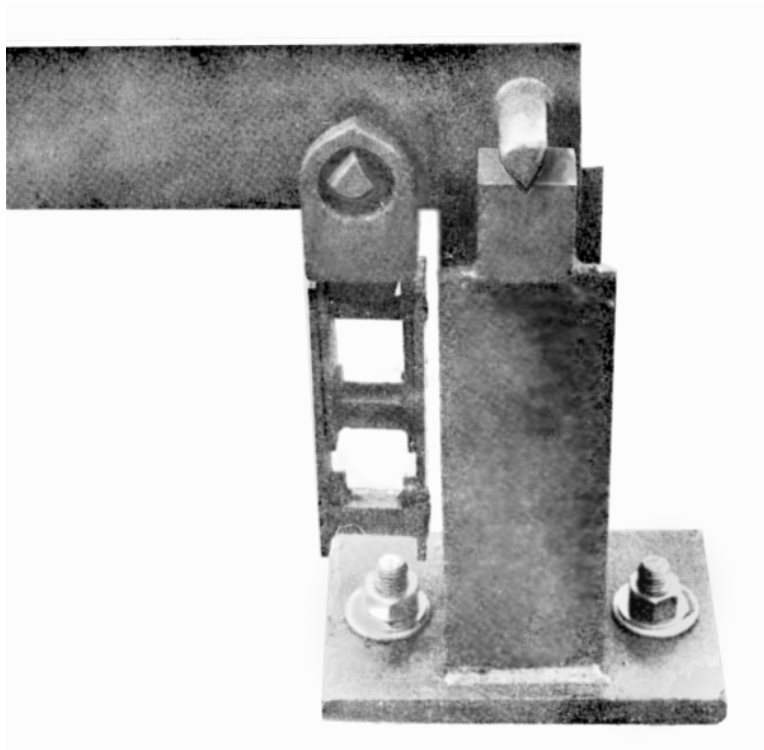

Figure 53. Transverse Lever Installation

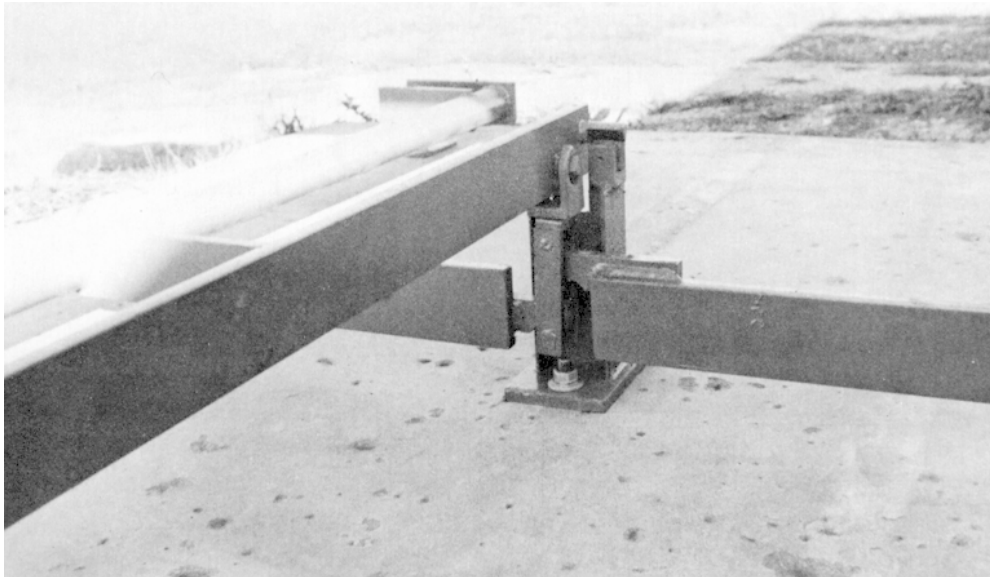

Figure 54. Transverse Lever Installation

10. Install Upper Main Stands on the Load Pivots of the Main Levers. Place the Four Channel pieces over the Upper Main Stands as shown in **Figure 55**. Do Not Stand On The Channel!

Check all bearing points to be sure the bearings are centered with the Pivots. The Steelyard Rod must be plumb and the Transverse Lever must be level.

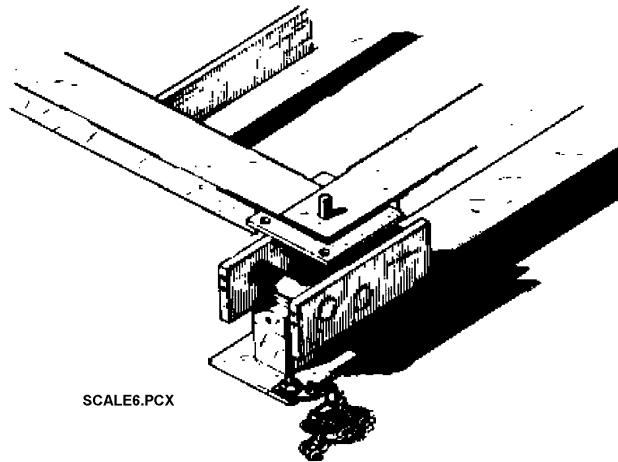

Figure 55. Scale Framing Installation

Feed Bin Installation

1. Raise the bin onto the Main Stands of the Scale. Use the Leg Anchor Plate provided with the bin plus a 5/8” heavy washer at each leg to secure the bin to the Main Stands. Attach the Safety Chain to the Upper Main Stand at each leg. (See **Figure 56**.)

NOTE: The Safety Chain should not be tight.

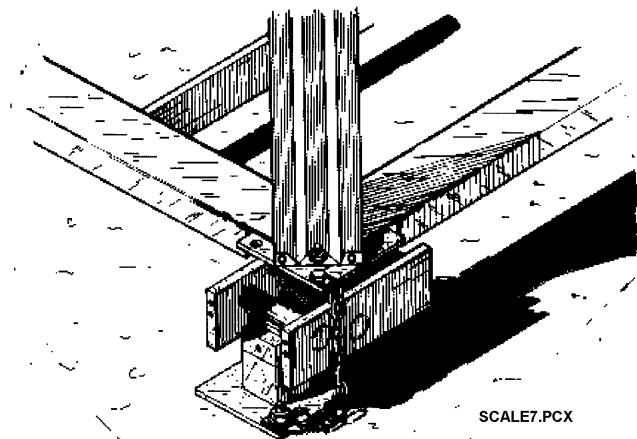

Figure 56. Setting Bin Legs on Scale Framing

Installation of the FLEX-AUGER Fill System

Refer to the FLEX-AUGER Fill System manual for instructions on installing the fill system from the storage bin to the weigh bin.

1. Install a 30 degree FLEX-AUGER boot on the storage bin.
2. Mount the WEIGH-MATIC Screener on the Weigh Bin. Refer to the “**WEIGH-MATIC® Model 90 Screener**” on **page 43** for Screener installation.
3. Install the auger tubes between the storage bin and weigh bin.
See the Flex-auger Installation Manual packed with the FLEX-AUGER Control Unit for more detailed installation information.
4. Use chain or cable to support the Auger Tube.

WEIGH-MATIC® Model 90 Screener

The WEIGH-MATIC Model 90 Screener is designed to screen foreign objects out of the feed. Whole kernel shelled corn will also be screened out of feed.

Chore-Time recommends assembling the Screener on top of the feed bin after the bin has been erected and anchored in place. The bin should be assembled without the lid installed.

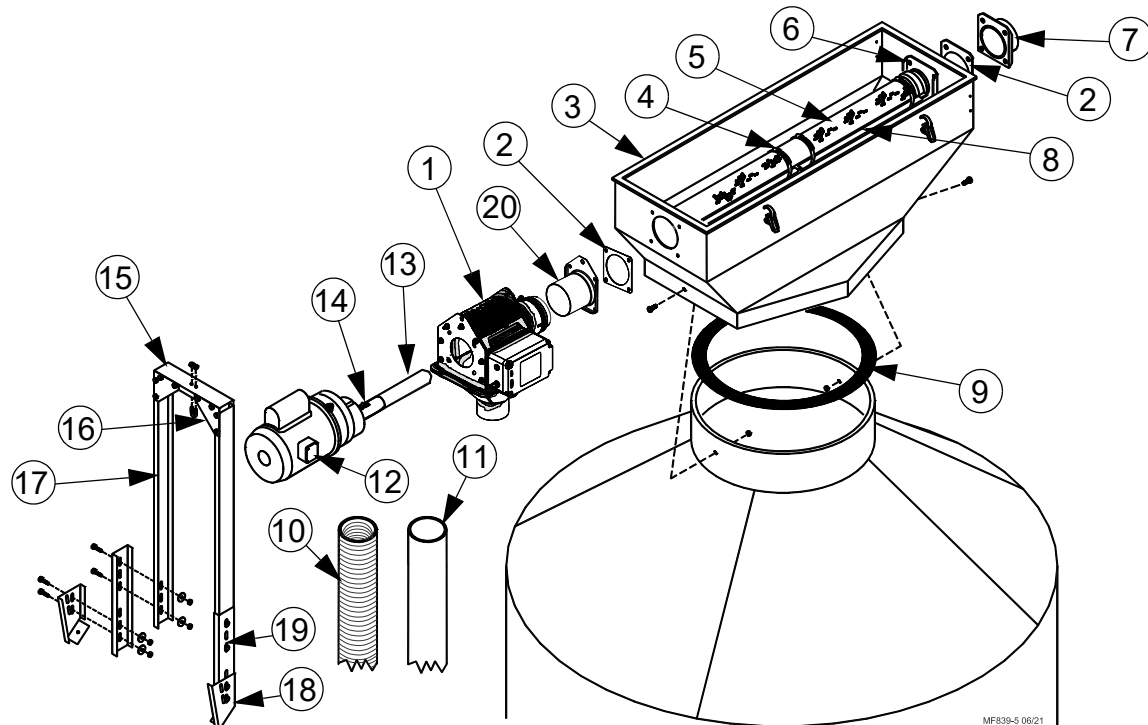

<u>Item</u>	<u>Description</u>	<u>Part No.</u>	<u>Item</u>	<u>Description</u>	<u>Part No.</u>
1	Control Unit Head	46800-23	11	Drop Tube	6381
2	Seal	4873	12	Power Unit	3259-52
3	Screener Body	25446	13	Agitator	25674
4	Adjustable Clamp	6183	14	Driver Assembly	25705
5	Screen	45922	15	Top Channel	25469
6	EXTRUDED Plate	22084	16	Corner Support	25470
7	Anchor Tube	5069	17	Support Channel	25468
8	Screen Retainer	24796	18	Foot Mount	25467
9	Lid Seal Gasket	5928	19	Channel Support Extension	35800
10	Flexible Drop Tube	48032	20	Control Anchor Weldment	47715

Figure 57. Screener Installation

Refer to **Figure 57** during assembly process.

1. Install the Gasket on the top of the bin.
2. Carry the Screener Body to the top of the bin. The outlets of the bin should be in line with the direction the system will run. Use the holes drilled in the screener collar as guides to fasten the screener to the top of the bin.
3. Install the Extruded Plates, Gaskets, Tube Anchor, and Control Unit Head, using the 5/16-18 hardware supplied.
4. The screens are shipped in halves and must be assembled. Use one Screen Retainer on each side of screens to secure the screen flanges together. Install four adjustable clamps to secure the screen halves together. Do not over-tighten clamps.
5. Fasten the Driver Assembly to the Power Unit Output Shaft and bolt to the Control Unit Head, using 5/16-18 hardware supplied. The Agitator will extend through the Control Unit Head and into the center of the Screener. Be sure to install the Drive Roll Pin through the Driver and Agitator to secure the blade in place.
6. Assemble the Motor Support Kit. The Motor Support will bolt to the top of the bin using self-drilling screws and gasket washers supplied.
7. Fasten the Flexible Drop Tube to the Drop under the Control Unit. Securely fasten a drop tube to run the foreign material into a container on the pad.

8. Install the auger tubes and auger as specified in the FLEX-AUGER[®] Operators Manual.
9. Mount the Junction Box to the bin leg, using hardware supplied. **Figure 58**
10. Refer to the wiring diagrams in this manual for wiring instructions.
11. Set the Screener Cover on top of the Screener and secure it in place using the over-center clamps.

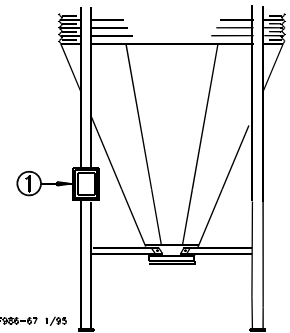

Figure 58. Junction Box

Controlling the Feeder

34380 Breeder Control Features

The ULTRAFLO Breeder Feeder is controlled by the 34380 Breeder Control.

The Breeder Control is designed to meet the feeding needs of poultry parent stock.

The Breeder Control has the capability of locking out the feeding system until the Weigh Bin has been satisfied with the preset amount of feed.

The Agri-Time[™] Time Clock (within the Breeder Control) is used to schedule the feeding times and run times, as well as the fill system start times.

Figure 59 shows the individual components on the face of the Breeder Control.

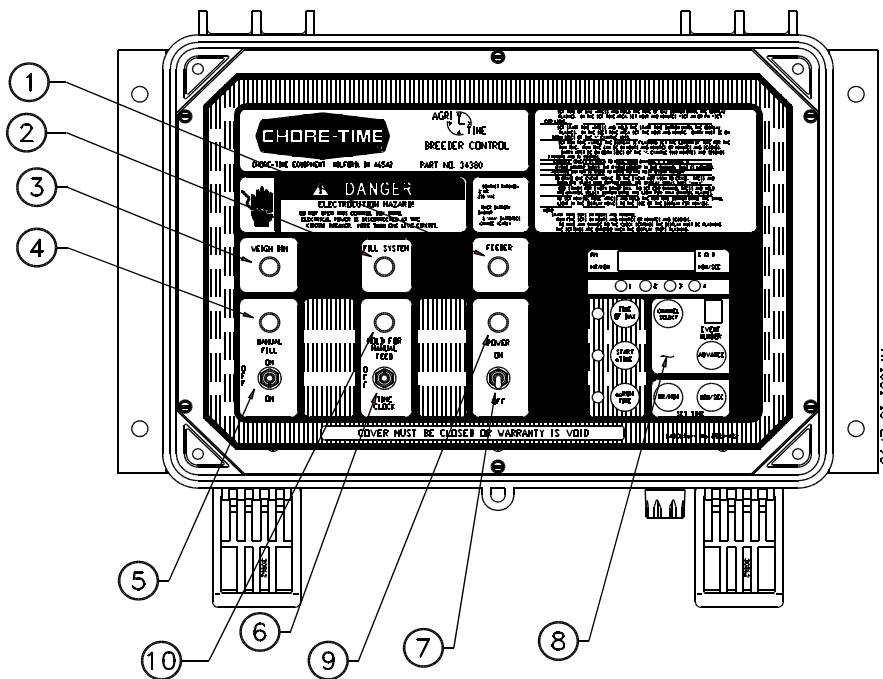

Figure 59. 34380 Breeder Control

Key	Description
1	Indicates feeder running.
2	Indicates fill system running.
3	Indicates weigh bin is filling.
4	Indicates the fill system is in the manual fill position.
5	Toggle switch used to set the fill system to ON, MANUAL ON, or OFF.
6	Toggle switch used to set the control to operate manually or automatic.
7	Toggle switch used to turn power ON and OFF to the Control.
8	Agri-Time [™] Time Clock used to set fill system and feeding system start times. Also used to set feeding system run times.
9	Indicates control is switched to the ON position.
10	Indicates feeder is being operated in the MANUAL mode.

Time Clock Operation

The Agri-Time Time Clock has (4) programmable channels.

Each channel can have up to 8 events (feedings, waterings, etc.).

Each event will have a start time and run time programmed into the timer. The start times are programmed in hours/minutes. The run times are programmed in hours/minutes or minutes/seconds.

Any or all the channels can be set up as a skip channel.

Two “AAA” batteries are used as a backup for time of day if power is temporarily removed.

Program settings will be stored in “E” prom memory.

The Start Time, Run Time, and Channel Select buttons have dual functions.

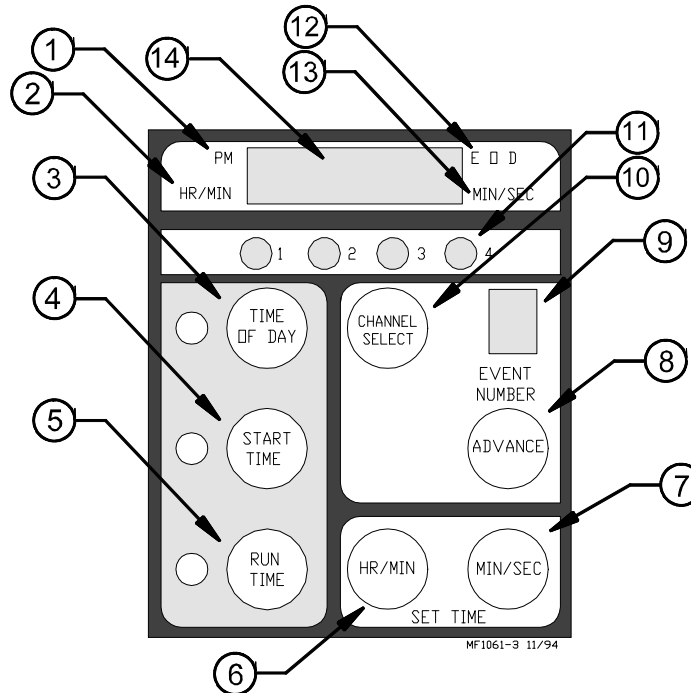

Figure 60. Time Clock Operation

Key	Description
1	P.M. Indicator
2	Hour/Minute Indicator
3	Used to set time of day, a.m./p.m., and skip mode.
4	Used to set start time and to erase individual operations.
5	Used to set length of run time. Also used to toggle between hours/minutes and minutes/seconds.
6	Used to set hours/minutes.
7	Used to set minutes/seconds
8	Used to advance to next event in channel.
9	Displays the event number being programmed.
10	Used to advance through the channels. Also used to set skip channel.
11	Indicates which channel(s) is active.
12	Indicates the day to be skipped.
13	Minutes/Seconds Indicator
14	Display Window

Programming the 4-Channel Time Clock

Before beginning the time clock, fill in the desired starting times and running times. This will make programming the clock much easier.

IMPORTANT: A start time and a run time must be entered for each desired operation. If either are missing or incomplete, the operation will be ignored.

The display must be flashing in order to make any program changes.

When the display stops flashing, the new information will be added.

CHANNEL 1		CHANNEL 2		CHANNEL 3		CHANNEL 4	
START TIME	RUN TIME	START TIME	RUN TIME	START TIME	RUN TIME	START TIME	RUN TIME

To Reset the Time Clock:

The time clock must be reset upon initial installation.

With power off to the system, press and hold the START TIME button while turning the power on. This will erase any entries that were programmed in the factory or field. Release the START TIME button.

To Set the Time of Day:

Press and hold the TIME OF DAY button until the display begins to flash.

Use the HR/MIN key on the time clock. Be sure to set the clock to the appropriate a.m. or p.m.

NOTE: Entries must be on both sides of the colon (i.e. 01:20).

To Set Skip a Day Mode:

Press the HR/MIN button to advance the display until the indicator beside the SKIPS TODAY is illuminated. Set the clock to the appropriate a.m. or p.m. This will set the proper sequence for the every-other-day mode. **It does not**, however, set the every-other-day channel. The every-other-day channel will be set later in the programming. **To Set a Start Time:**

Press and hold the START TIME button until the display starts flashing.

Enter the start time for the first channel using the buttons in the SET TIME area of the time clock. The start times will be set in hours and minutes. Be sure to set the appropriate a.m. or p.m. settings.

NOTE: Entries must be on both sides of the colon (i.e. 01:20).

To Enter a Run Time:

Use the buttons in the SET TIME area of the time clock. The run times may be set in minutes/seconds or hours/minutes.

NOTE: To set the run times in minutes/seconds, press and hold the RUN TIME button until the indicator beside MIN/SEC is illuminated.

NOTE: Entries must be on both sides of the colon (i.e. 01:20).

To Assign Every-Other-Day Mode to a Channel:

Press the CHANNEL SELECT button to advance to the channel you wish to be the skip channel.

Press and hold the CHANNEL SELECT button until the CHANNEL indicator starts to flash.

To remove every-other-day mode from a channel, press and hold the CHANNEL SELECT button until the indicator stops flashing.

To Move Through a Channel:

Press the ADVANCE button to move to the next event in a channel. The EVENT NUMBER display window changes as the ADVANCE button is pressed.

Follow the steps above to set the remainder of the channels and events.

To Erase a Single Event:

Press the CHANNEL SELECT button and the ADVANCE button to select the event you wish to remove.

Press and hold the START TIME button until the display shows bars. This will remove appropriate start time and run time.

To Erase All Start Times and Run Times:

Remove power to the Control Box.

Press and hold the START TIME button (for approximately 5 seconds) while turning power on to the Control Box. This should remove all entries from the program. However, the time of day will not be erased.

To Review the Program:

Press and hold the START TIME button until the display begins to flash. Using the START TIME, RUN TIME, ADVANCE, and CHANNEL SELECT buttons you can view each of the programmed entries (events).

48 ULTRAFLO Breeder Feeder Component Location Diagram

Wire the system according to the applicable wiring diagram. Refer to this Component Layout Diagram to determine the motor, switch, etc., locations.

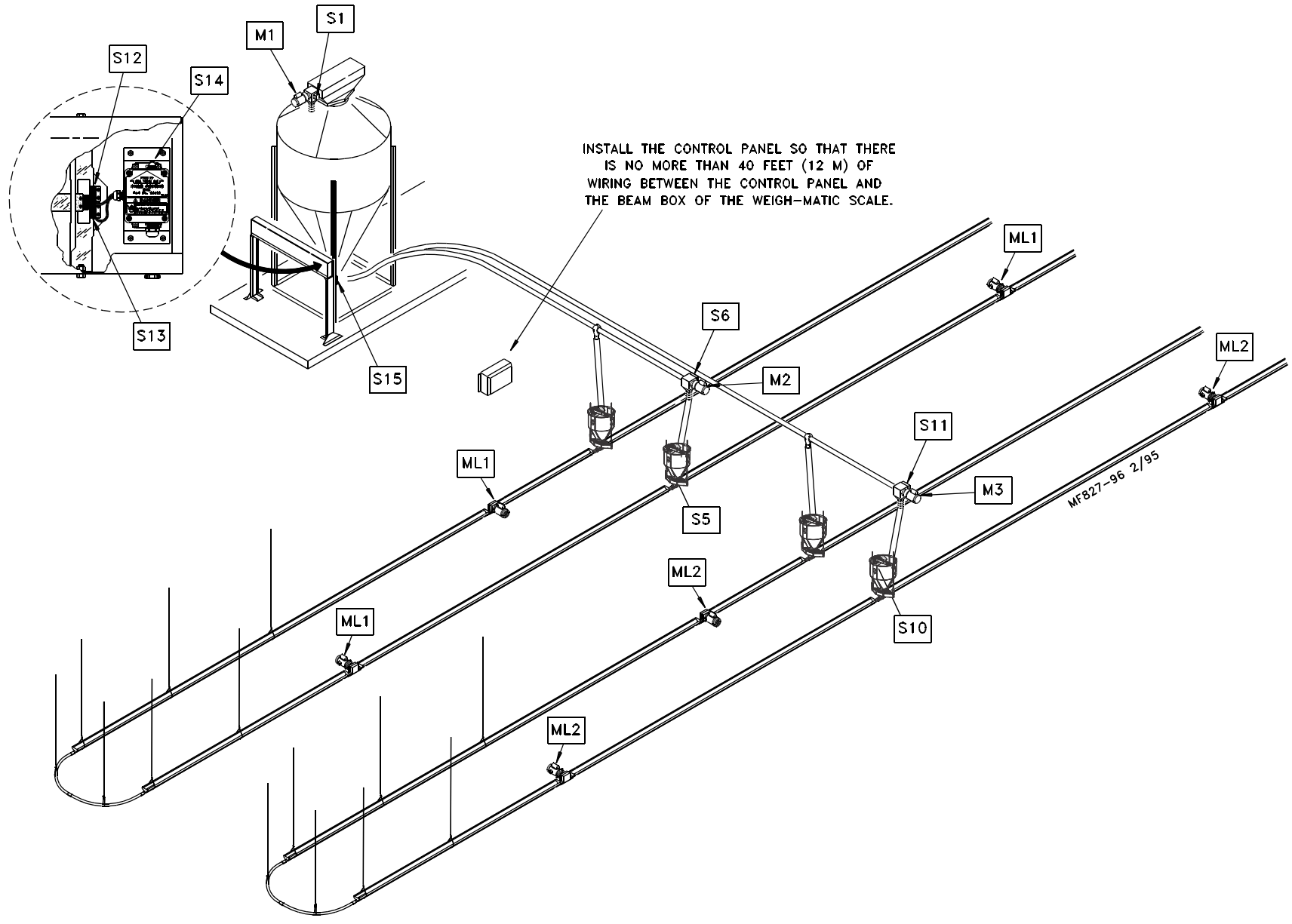

Balancing the Scales

All fill system wiring **MUST BE COMPLETED** before attempting to balance the scale.

Never balance the scales if any of the delivery or fill augers are empty. The Weigh Bin should have approximately 50 pounds (23 kg) of feed in it whenever the scales are balanced.

1. Turn switch "ON" at the control panel
2. Hold weigh beam down and momentarily press switch button in beam box. This starts the fill system and it will bring feed into the weigh bin. Run delivery system long enough to bring 200 to 300 pounds (90 to 135 kg) of feed into the bin. Delivery capacity of the Model 90 Auger is approximately 100 pounds (45 kg) per minute. Run the fill system the correct length of time to achieve 200 to 300 pounds (90 to 135 kg) of feed in the weigh bin.
3. Release the weigh beam and allow it to raise up, away from the lower proximity sensor. The fill system will stop.
4. Raise the weigh beam so that it moves to the upper proximity sensor. The delivery system that carries feed from the weigh bin to the building will start.
5. Use the Manual Fill Switch to Run all but about 50 pounds (23 kg) of feed from the weigh bin. Some feed **MUST** remain in the boot. **THIS WILL BE THE ZERO POINT FOR BALANCING THE SCALE.**
6. Turn switch "OFF" at the control before making balancing adjustments.
7. Move poise on weigh beam to "O" against the stop pin.
8. Slide Back Balance Assembly along weigh beam until the end of the weigh beam is centered midway between the two sensors. Lock the back Balance Assembly to the weigh beam.
9. If finer adjustment is required, adjust the Brass Rod on the Back Balance until the weigh beam is centered between the two sensors.
10. Make sure Weigh Bar is centered in Beam Box. Check the accuracy and balance by setting the system for a small quantity of feed (20 pounds, for example). Cycle the fill system and make the following checks:

- Check weigh beam so that it does not over-travel or float when moving from an unbalanced position to the balance point.

- Check the quantity of feed delivered by cycling and collecting feed from the weigh bin. Number of pounds delivered should be the amount at which the scale was set.

NOTE: THE WEIGH BEAM IS AVAILABLE IN POUNDS OR KILOGRAMS.

Operation of the Scales

1. Set the 24 hour time clock on the control panel at the present time.
2. Pull tabs to program the starting time and length of the feeding period.
NOTE: the time clock runs on a 24 hour cycle for daily feedings. For skip-a-day feeding, turn "POWER" switch "OFF" on non-feed day.

The time clock is a double-dial time clock. The inner dial controls the fill system starting time. The outer dial controls the feeder running time.

3. Set the poise on the weigh beam for the desired quantity of feed.
4. Momentarily press switch button on the beam box until the FLEX-AUGER system bringing feed into the weigh bin starts. The FLEX-AUGER system will run the desired quantity of feed into the weigh bin; then it will shut off automatically.
5. Set poise to zero **AFTER WEIGH BEAM REACHES BALANCE POINT AND FLEX-AUGER SYSTEM STOPS.**
6. Feeder lines are time clock controlled by the outer dial. They will start running when the time clock signals that feeding period should begin. Continue to run to the end of the programmed feeding times.

NOTE: Adequate number of feed cycles should be programmed on the time clock so that all of the measured feed is consumed during each feeding period. Monitor the feed consumption. If the measured amount of feed has not been dispensed from the weigh bin and/or feed is present in the feeder line hoppers, increase the number of feed cycles or times.

7. The operator must manually set the scales to the pounds required for next feeding and push the momentary switch to start filling the weigh bin for the next feeding.

• **NOTICE** •

If other scales are to be used (not C-T Weigh Matic) refer to manufacture's instruction manual for scales installation and operation.

Start Up Procedure

Follow this procedure with new and refilled houses.

NOTE: The following procedure is to be run on each loop individually. Therefore, disconnect power at each power unit on the loop not being started. Also, flip the appropriate Control Unit Toggle Switch to the OFF position.

1. Turn off electrical power to the system.
Check the feeder loop for foreign objects in the trough.
Remove the Clean-Out Covers from the first loop
2. Turn on electrical power to the system.
Set the Run Timer to allow the auger to make (2) complete revolutions around the feeder loop. Set the "FEEDINGS" switch to the "MANUAL" position.
Allow the system to run empty for (2) complete revolutions. This will remove sawdust, etc., from the trough.
3. Turn off electrical power to the system.
Install the Clean-Out Covers.
4. Turn on electrical power to the system.
5. Put feed in the weigh bin.
Open the weigh bin slide approximately 3 inches (75 mm).
6. Set the Run Timer for 30-35 minutes.
7. Start the feeder loop by setting the "FEED" switch, on the Control Panel, in the "MANUAL" position.
Push the "MANUAL HOPPER FILL" button on the Control Panel, to start the fill system.

NOTE: Run the Fill System manually to allow feed to cover approximately 1/2 of the auger. Stop the Fill System periodically. This will allow the feed to be removed from the hopper and prevent over charging the feeder loop.

Use the Control Unit Toggle Switch to turn the fill system on and off, as required, to prevent overloading the "unpolished" augers with feed.

NOTE: STOP THE FILL SYSTEM WHEN FEED RETURNS TO THE HOPPER(S).

8. Allow the feeder loop to run the remained of the time on the run timer. This will polish the auger (remove oils, rust, etc.)
9. Turn off electrical power to the system. Set the "FEED" switch in the "OFF" position.
10. Repeat the start-up procedure, above, on the second feeder loop.
11. If desired, the feed may be removed from the feeder loops.
Turn off electrical power to the system.

Wiring

34380 Breeder Control Wiring (Without Motor Starters)

For ULTRAFLO® Breeder Feeder Installations w/o Motor Starters (230V, 50/60Hz, Single Phase).

⚠ DANGER

ELECTROCUTION HAZARD!

Do not open this control box until electrical power is disconnected at circuit breakers.

2527-25

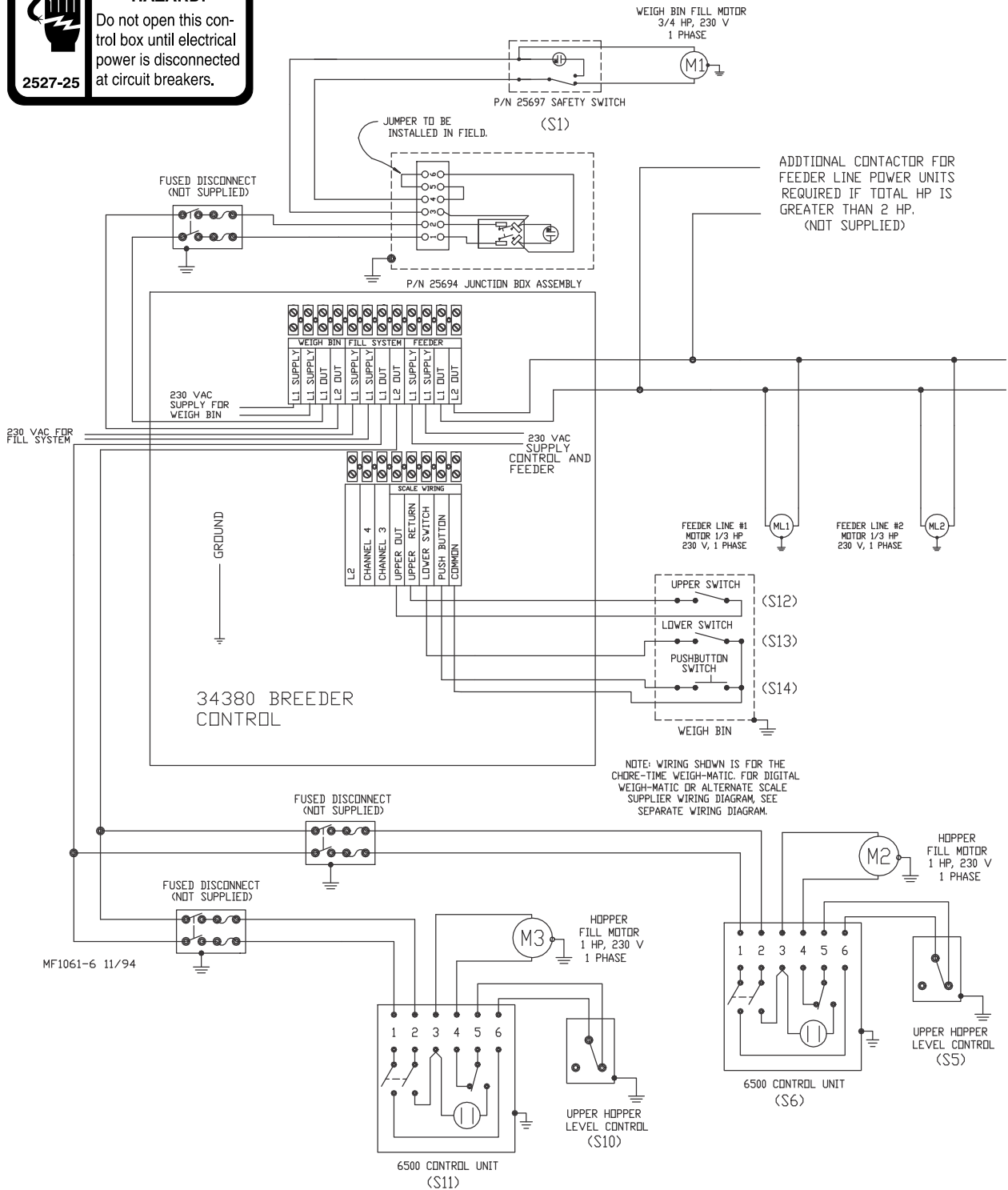

34380 Breeder Control Wiring (With Motor Starters)

For ULTRAFLO® Breeder Feeder Installations with Motor Starters (230V, 50/60Hz, Single Phase).

⚠ DANGER

ELECTROCUTION HAZARD!
Do not open this control box until electrical power is disconnected at circuit breakers.

2527-25

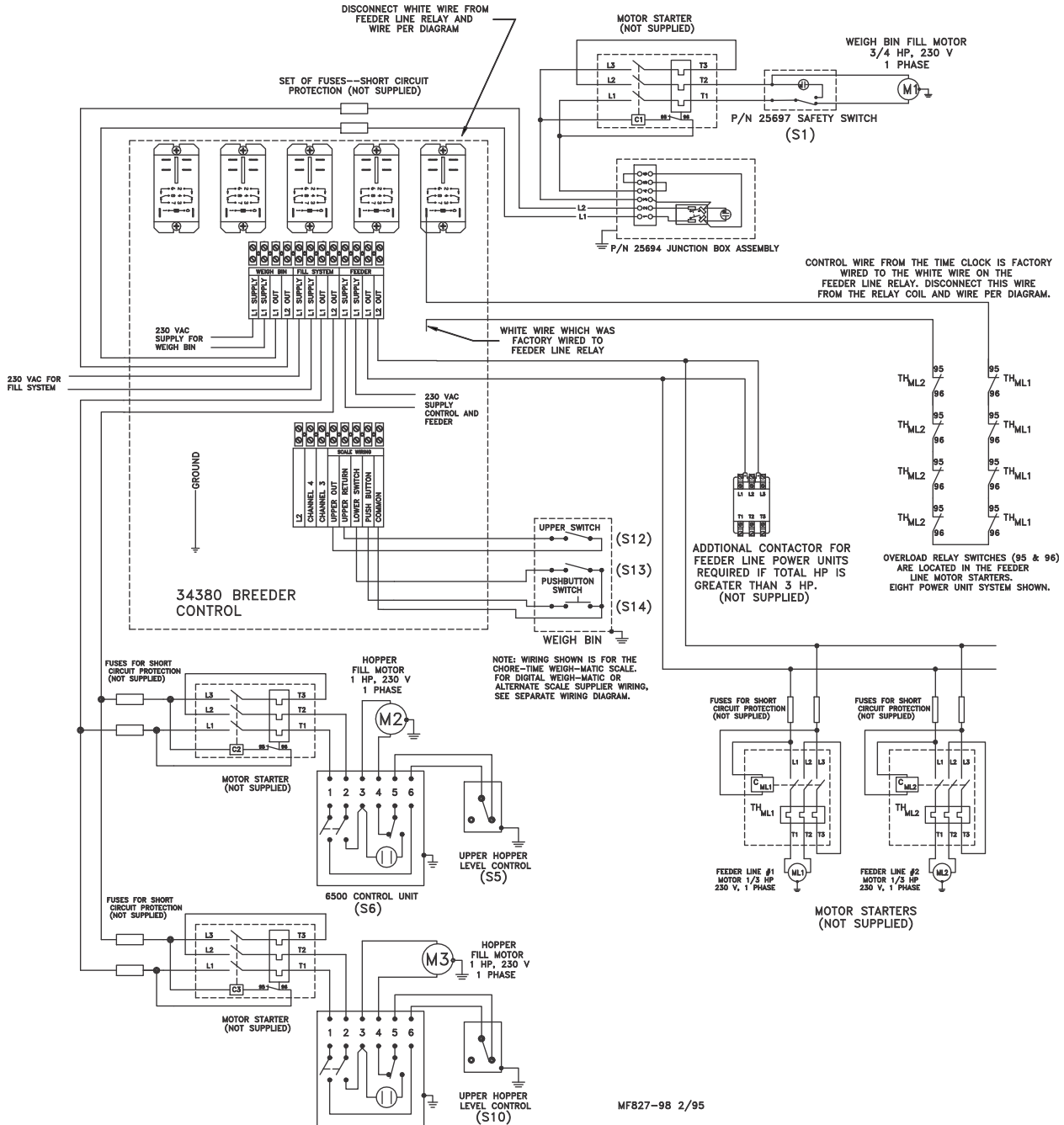

34380 Breeder Control Wiring (With Motor Starters 3 Phase)

For ULTRAFLO® Breeder Feeder Installations with Motor Starters (220/380/415V, 50Hz, Three Phase).

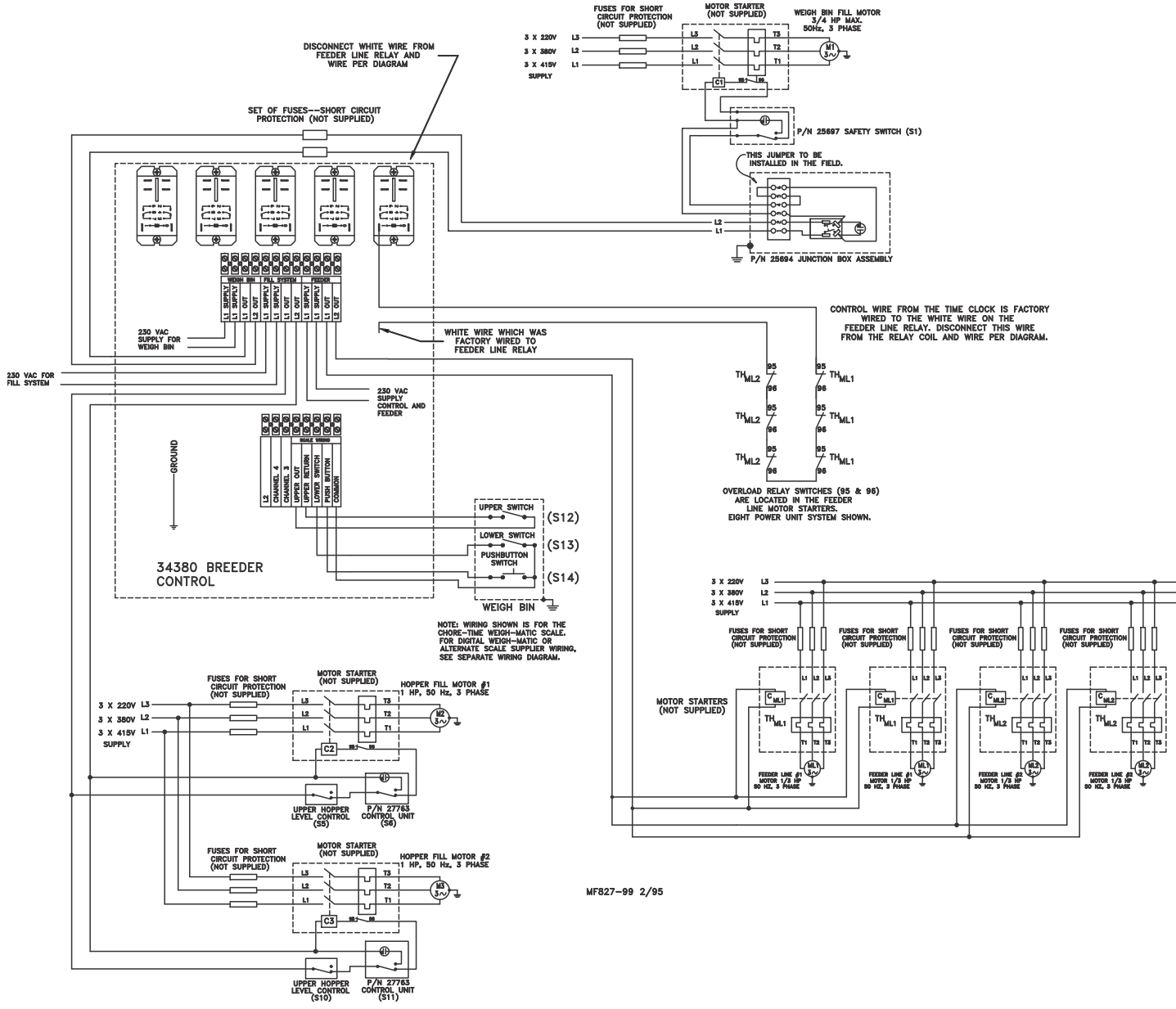

DISCONNECT WHITE WIRE FROM FEEDER LINE RELAY AND WIRE PER DIAGRAM

SET OF FUSES—SHORT CIRCUIT PROTECTION (NOT SUPPLIED)

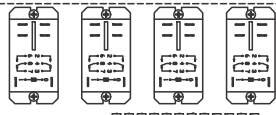

34380 BREEDER CONTROL

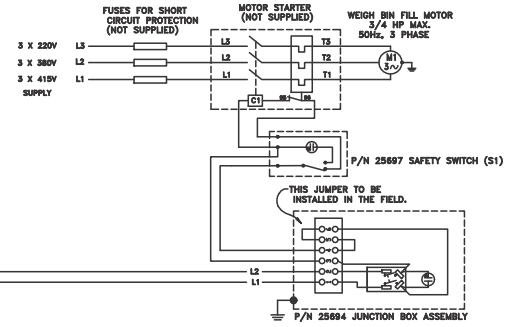

CONTROL WIRE FROM THE TIME CLOCK IS FACTORY WIRED TO THE WHITE WIRE ON THE FEEDER LINE RELAY. DISCONNECT THIS WIRE FROM THE RELAY COIL AND WIRE PER DIAGRAM.

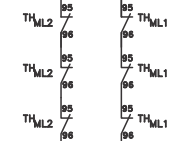

OVERLOAD RELAY SWITCHES (95 & 96) ARE LOCATED IN THE FEEDER LINE MOTOR STARTERS. EIGHT POWER UNIT SYSTEM SHOWN.

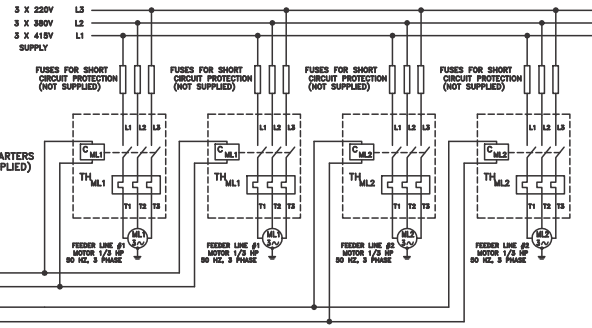

MF827-99 2/95

⚠ DANGER

ELECTROCUTION HAZARD!

Do not open this control box until electrical power is disconnected at circuit breakers.

2527-25

Chore-Time Digital Weigh-Matic Wiring Diagram

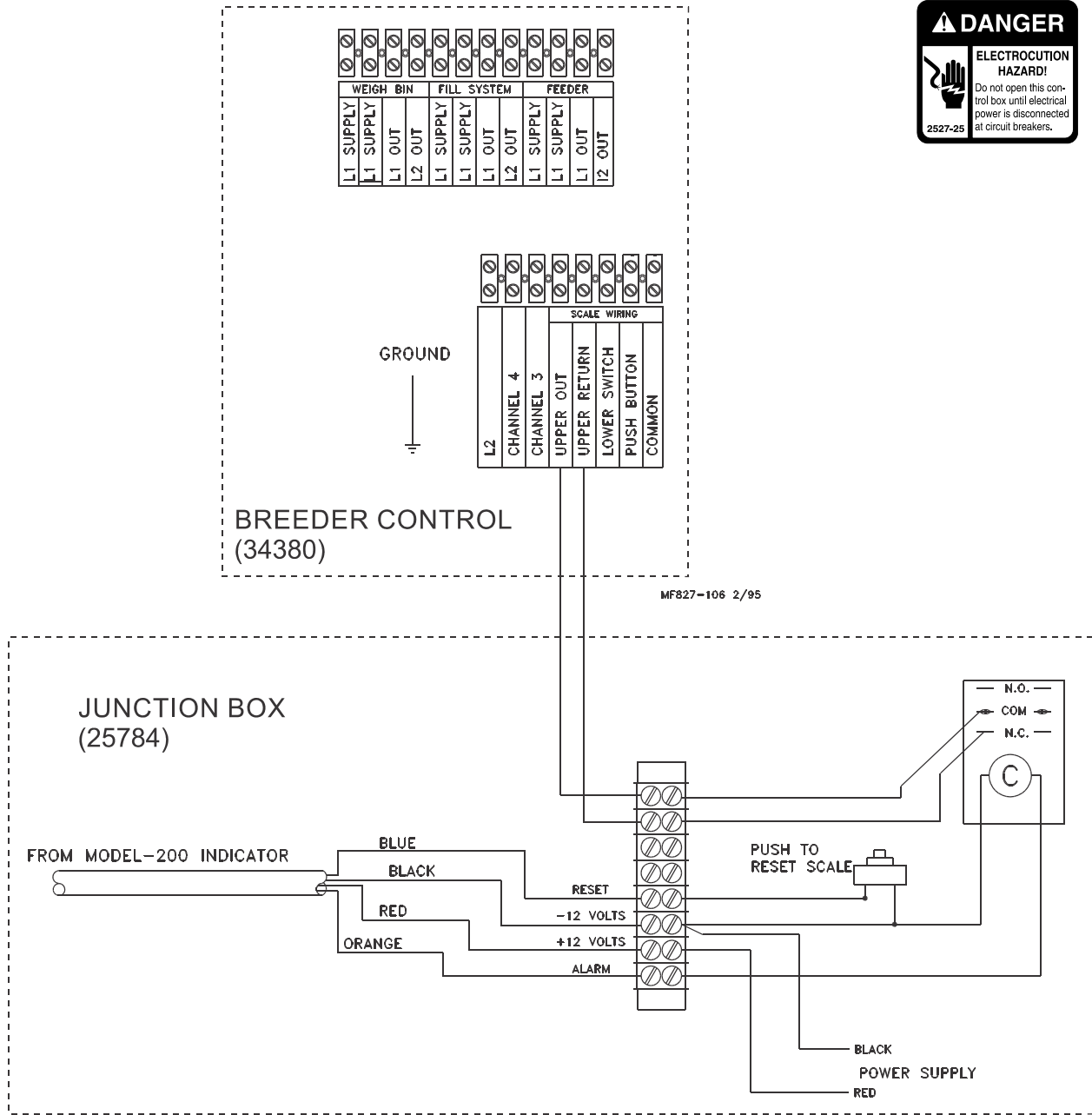

Alternate Scale Wiring Diagram

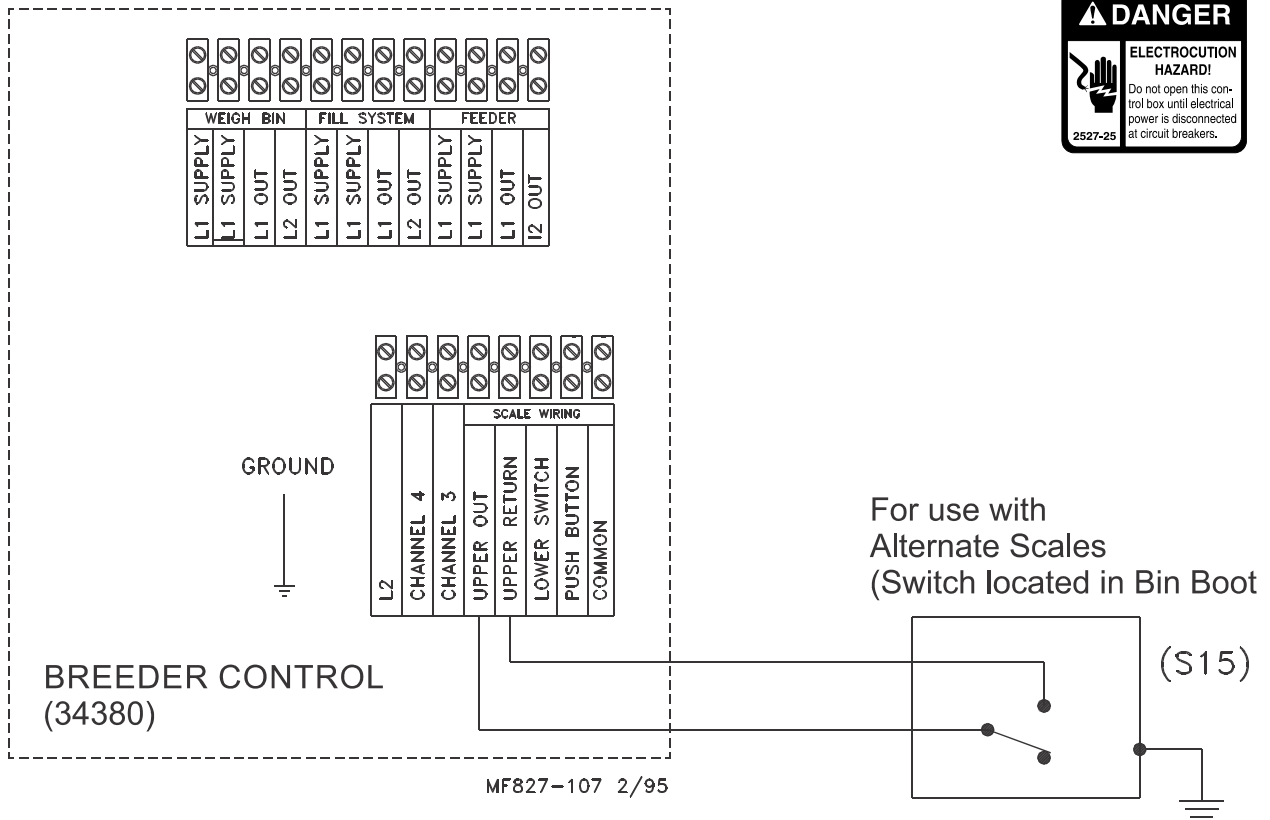

Additional Channel Wiring

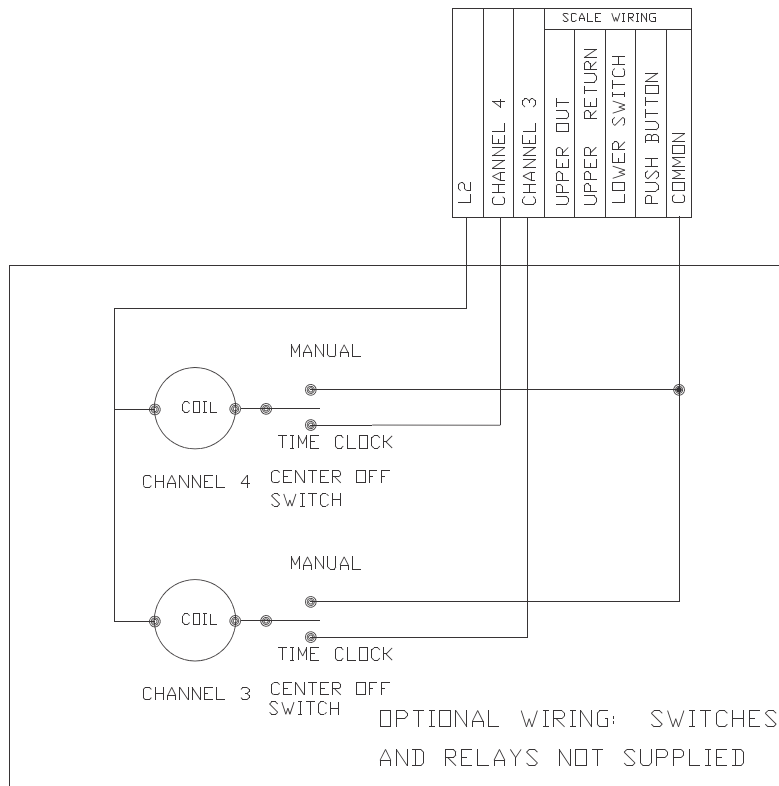

MF1061-7 5/95

Logic Wiring

MF827J

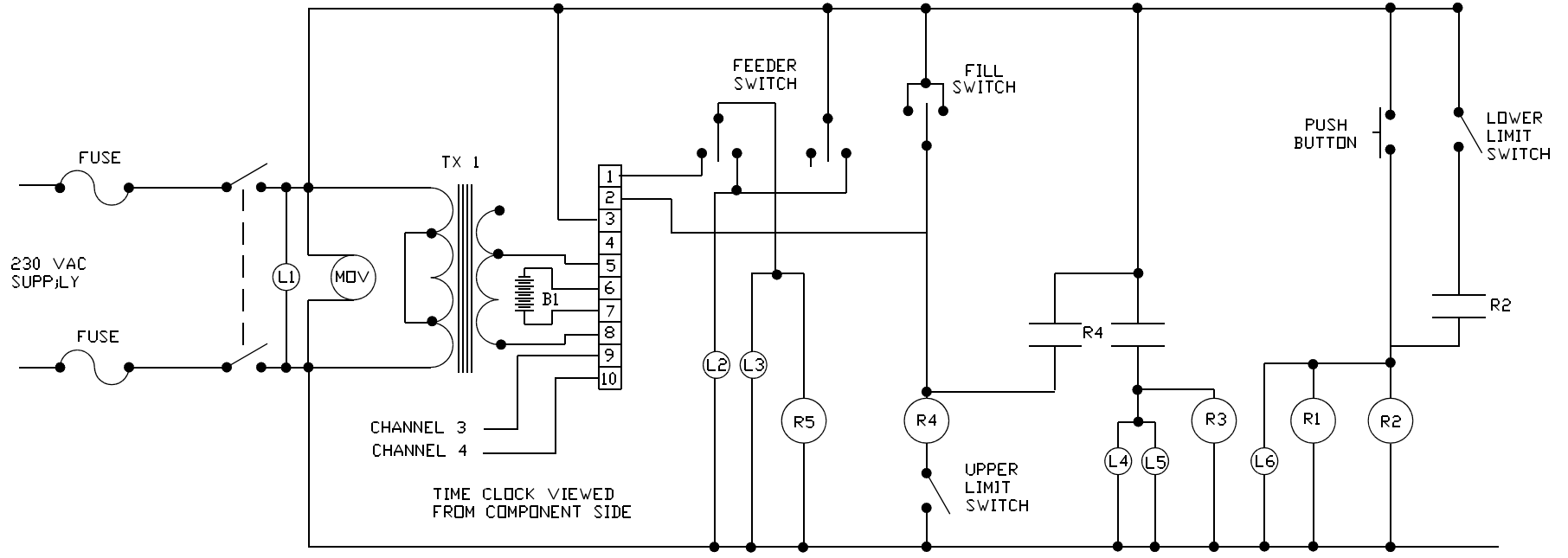

MF1061-5 11/94

57 Internal Wiring

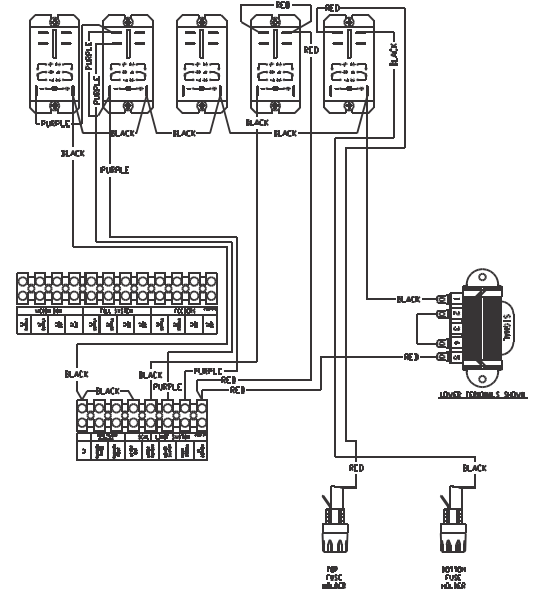
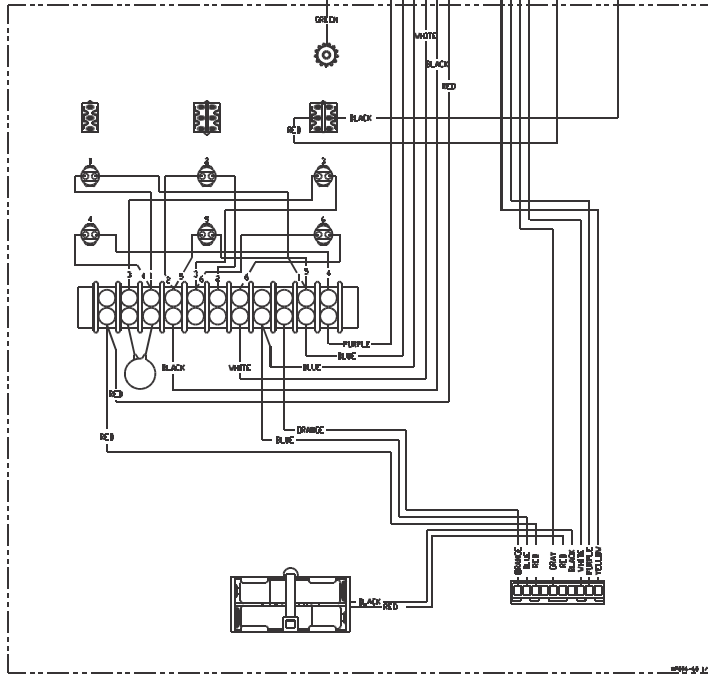
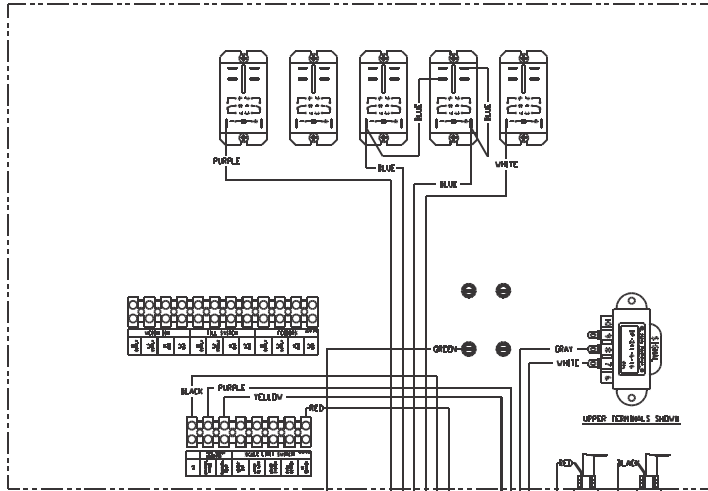
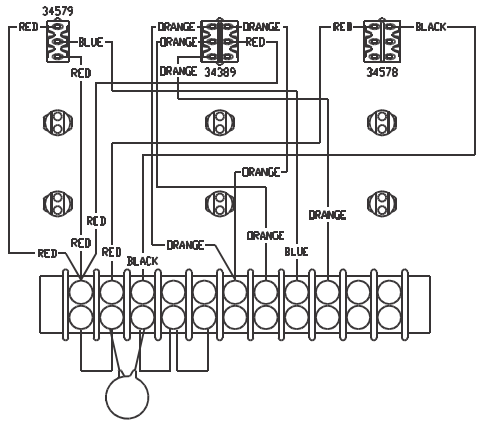
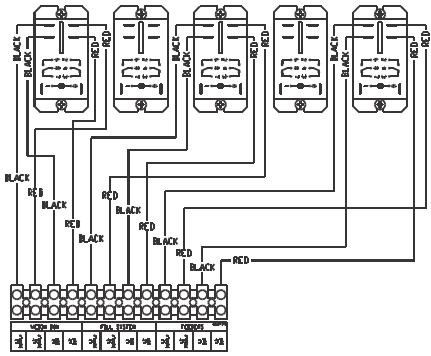

58 30240 Fill Option Breeder Control Wiring (W/out Motor Starter Single Phase)

For ULTRAFLO[®] Breeder Feeder Installations without Motor Starters (230V,50/60Hz,Single Phase)

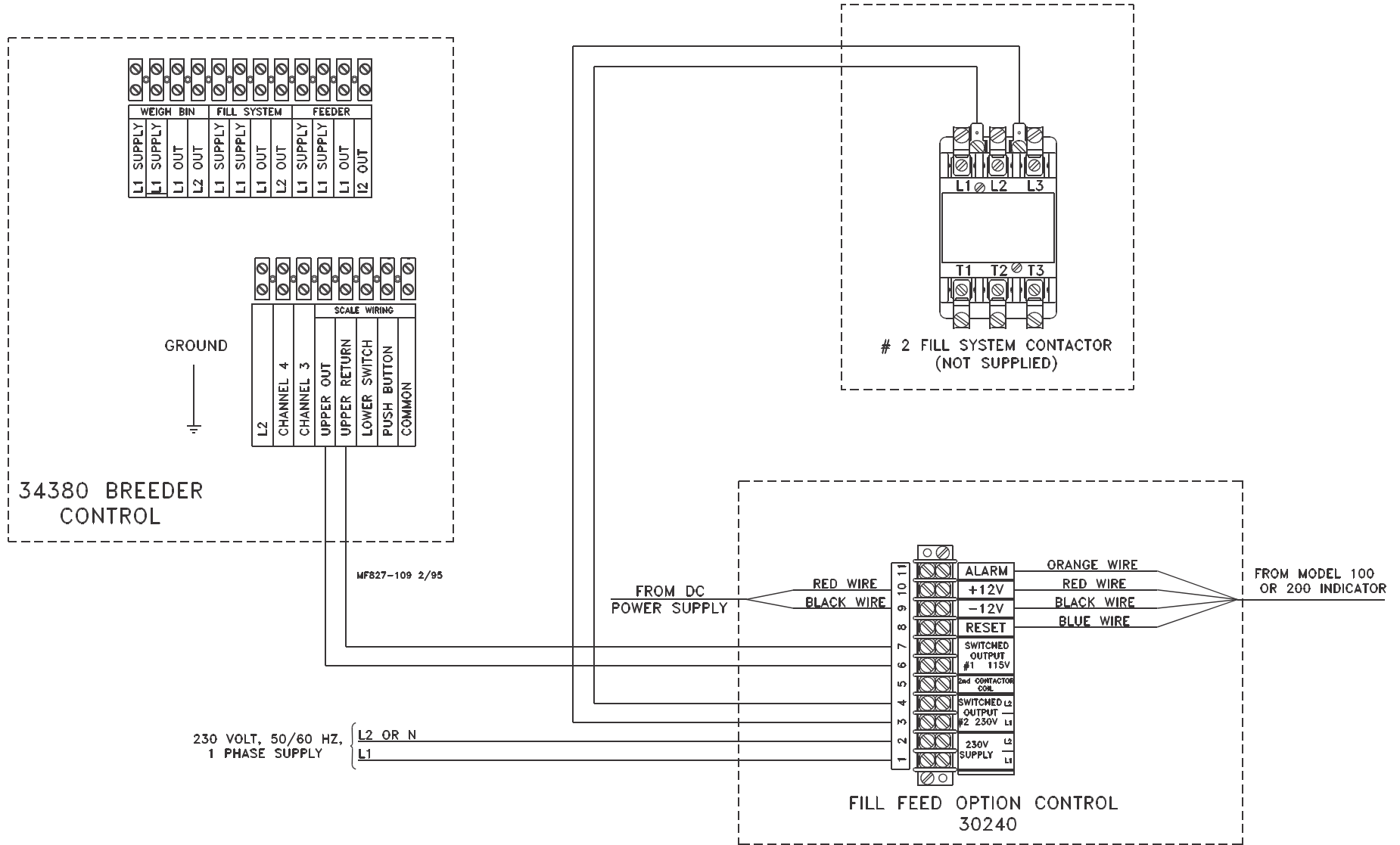

30240 Fill Option Control Logic Wiring

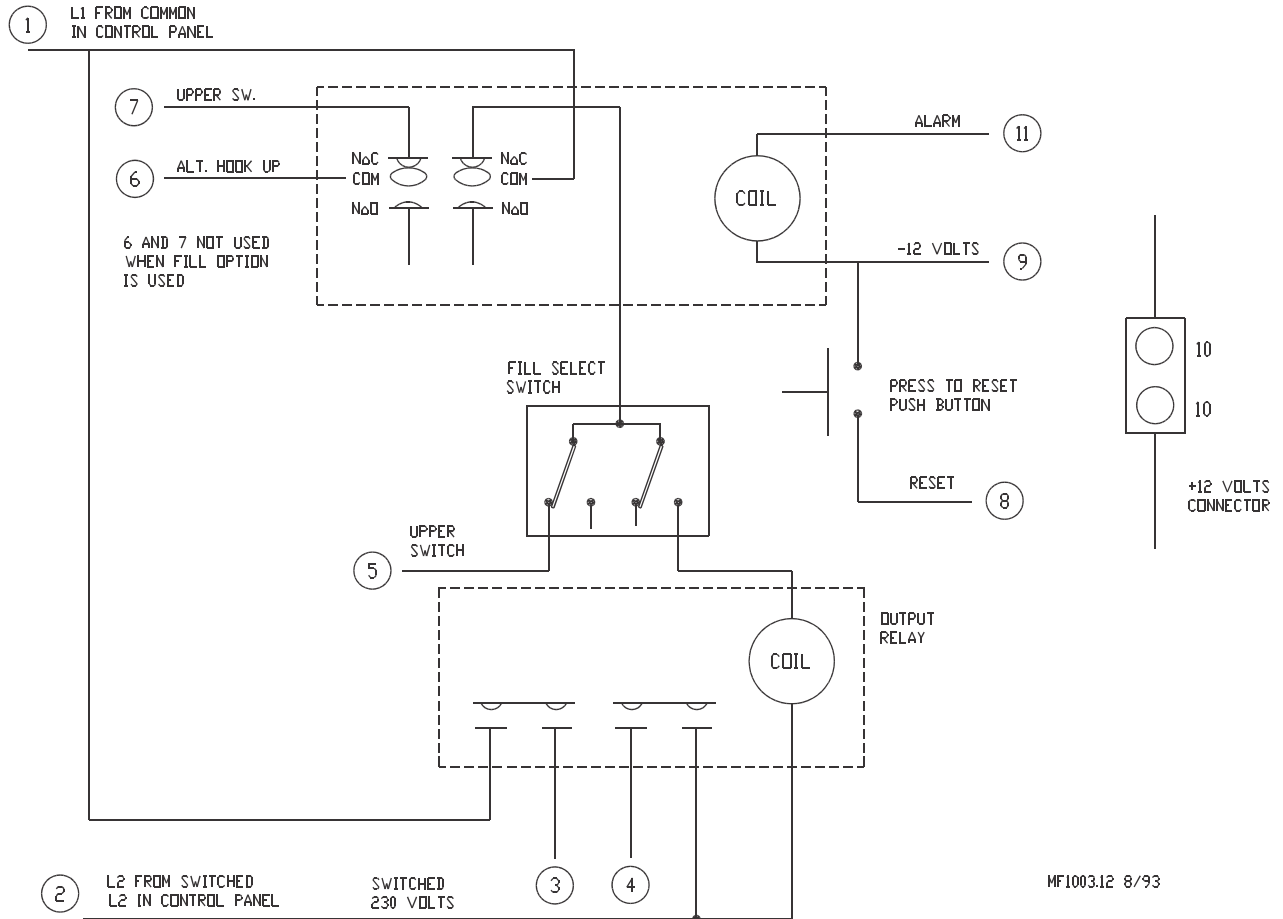

MF1003.12 8/93

Parts Listing

Breeder Control: Part No. 34380

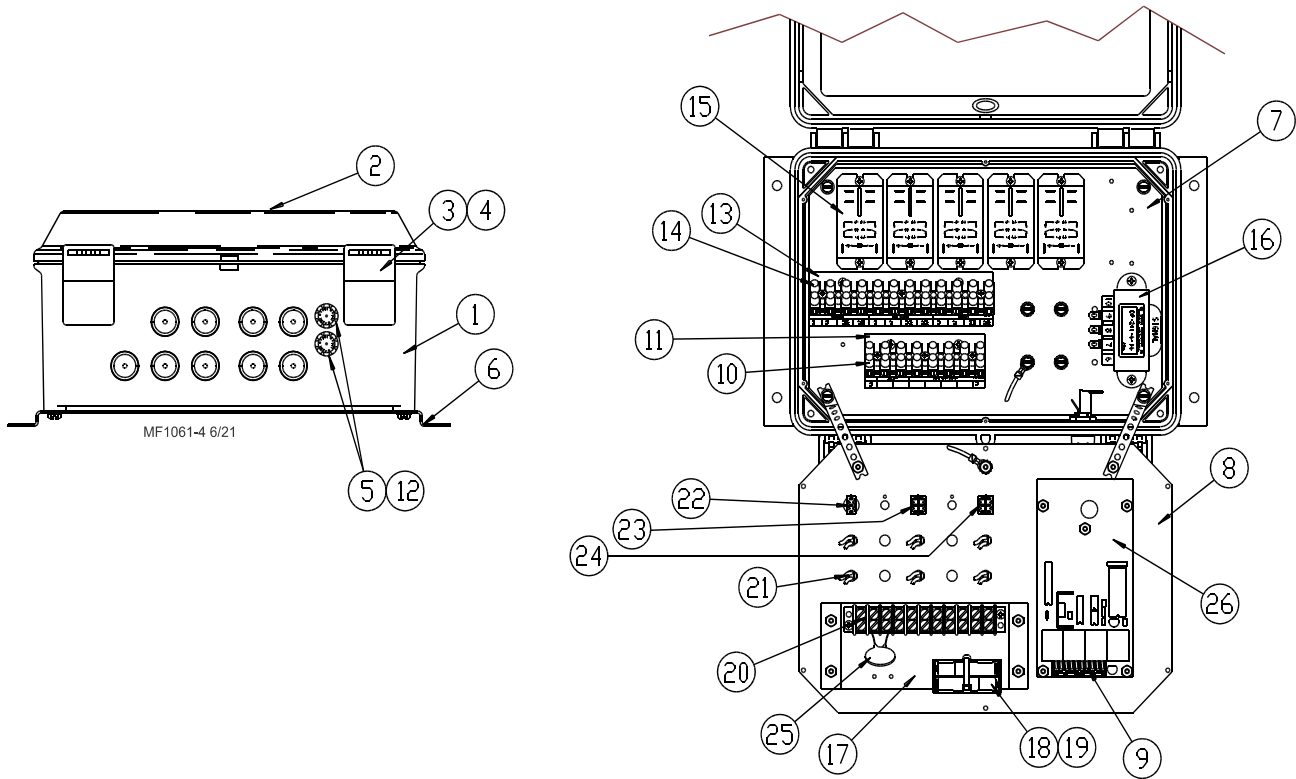

Item	Description	Part No
1	Control Box	30860-4
2	Clear Cover	30859-1
3	Control Box Latch Pivot	30863
4	Control Box Latch	30862
5	Fuse Holder	24431
6	Control Box Mount Panel	34852
7	Back Mount Panel	34564
8	Front Panel	34565
9	Time Clock Connector	34457
10	Terminal Strip (8 poles)	34925-8
11	Terminal Mount Bracket	35094
12	3 Amp Fuse	20472
13	Terminal Mount Bracket	34563
14	Terminal Strip	34925
15	P & B Relay (240 V)	34733
16	Transformer	34571
17	Mount Bracket	34562
18	Battery Box Assembly	35095
19	AAA Battery	34584
20	Terminal Block	7347
21	Pilot Light	29708
22	Toggle Switch	34579
23	Toggle Switch	34389
24	Toggle Switch	34578
25	MOV	14063-1
26	Circuit Board	34384

ULTRAFLO® Breeder Feeder Line Components

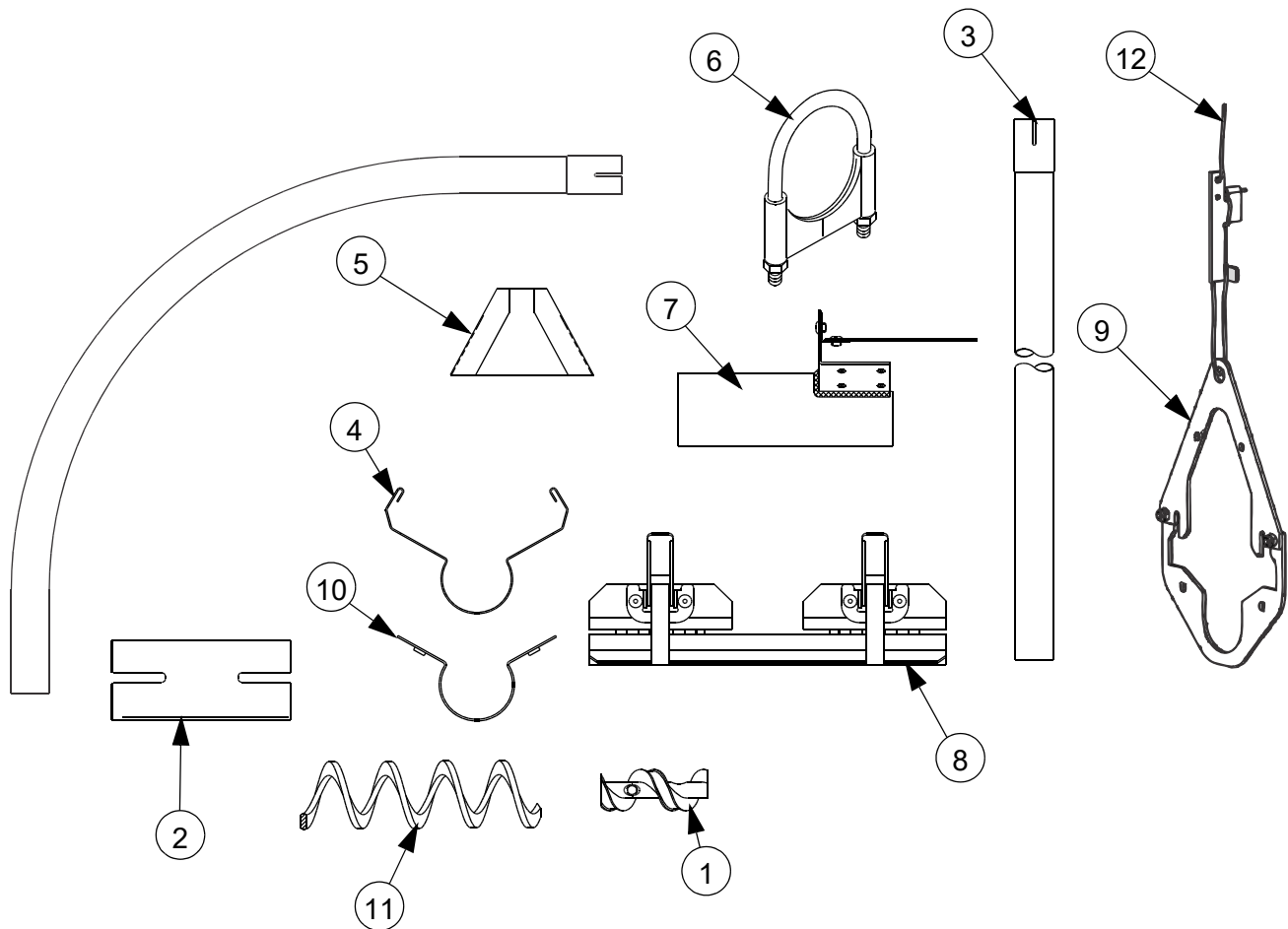

Item	Description	Part No.
1	Auger Connector Ass'y	28091-2
2***	Connector Tube	29691
3	5' Belled Tube	35627
4	Trough -10' (3 m)	14159-3
5	Grill End Cap	25464
6***	Tube Clamp	29775
7	End Cap	25169
8	Welding Fixture	25494
9	Trough Hanger	40573
10	Clean-Out	25502
11§	Auger	25058-0
12	Cable Lock	14377
13	90° Elbow (Hardened)	37891

*includes two connectors & (4) set screws.

***(1) Connector Tube and (2) Tube Clamps may be ordered as a kit under part no. 29802.

Ultra-FLO Elbow Loop Kit 48355

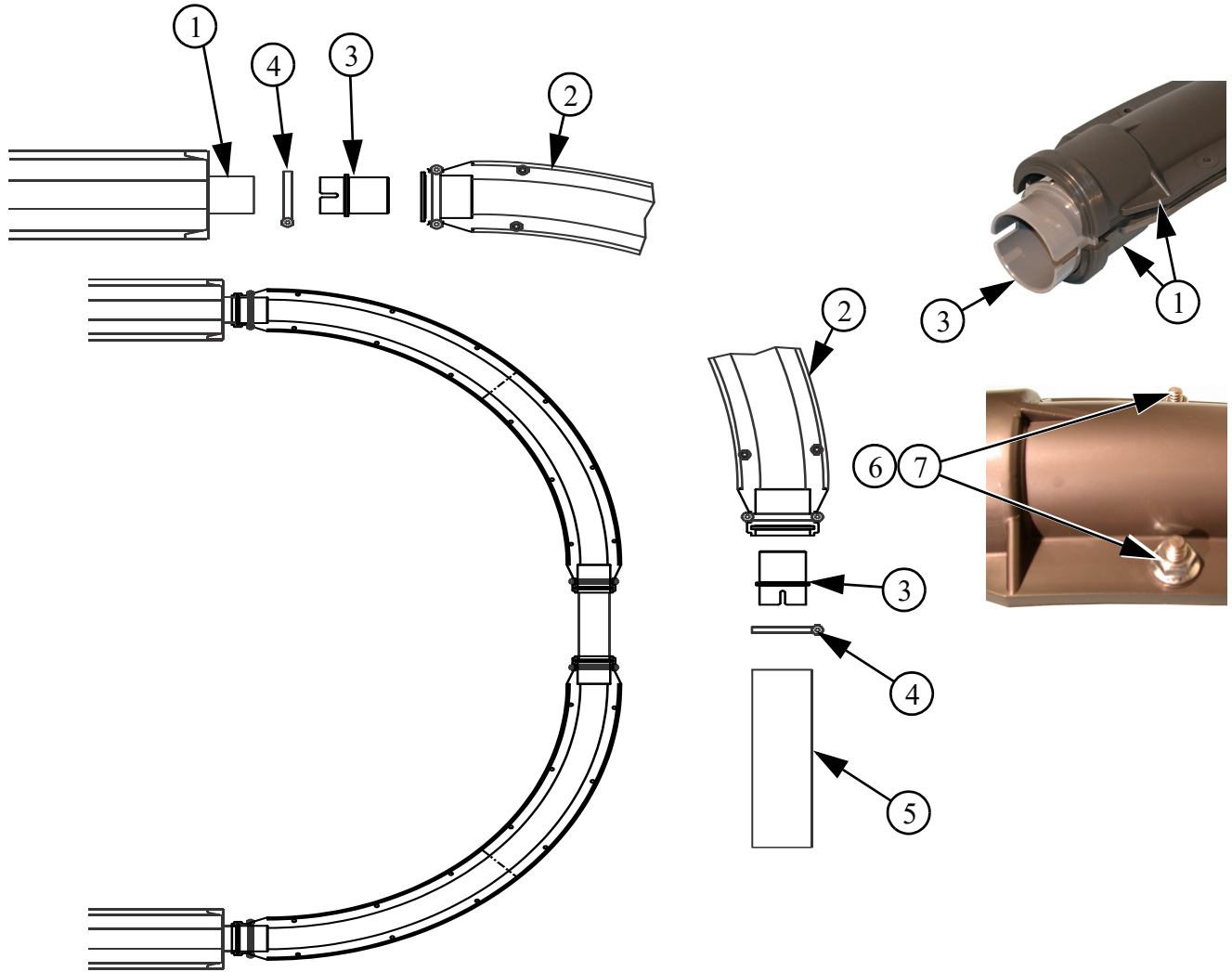

Item	Description	Part No.
1	End Cap	--
2	Elbow Half	46779
3	Elbow Adapter	46980
4	Hose Clamp	8643
5	Connecting Tube	48356
6	1/4-20 HH Bolt	1133
7	1/4-20 Ser. Nut	46460

ULTRAFLO® Breeder Feeder Grill Options

Standard Grill
(24774-X)

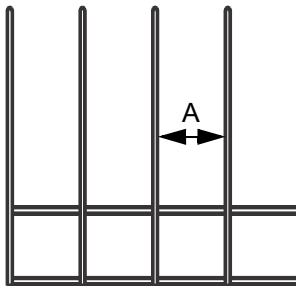
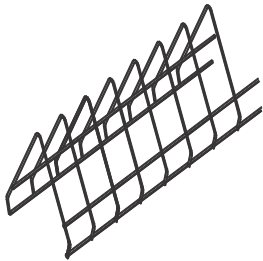

Cross Grill
(28644-X)

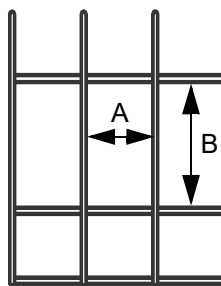
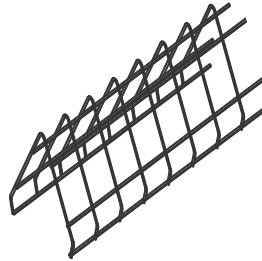

High Contour Grill
(27910-X)

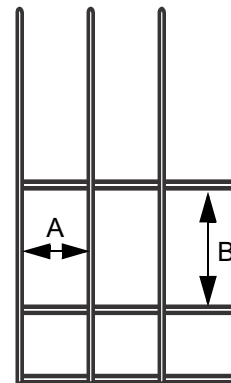
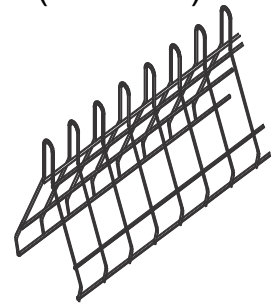

Part No	Grill Style	Dimension "A"	Dimension "B"
24774-20	Standard	1.625" [41.2 mm]	--
24774-21	Standard	1.688" [42.8 mm]	--
24774-22	Standard	1.732" [44.0 mm]	--
24774-23	Standard	1.811" [46.00 mm]	--
24774-24	Standard	2.000" [50.80 mm]	--
28644-20	Cross	1.664" [42.00 mm]	2.772" [70.4 mm]
28644-21	Cross	1.687" [42.85 mm]	2.5" [63.5 mm]
28644-22	Cross	1.732" [44.00 mm]	2.5" [63.5 mm]
28644-23	Cross	1.750" [44.45 mm]	2.25" [57.2 mm]
28644-24	Cross	1.811" [46.00 mm]	2.244" [57.0 mm]
27910-20	High Contour	1.625" [41.3 mm]	3.00" [76.2 mm]
27910-21	High Contour	1.687" [42.8 mm]	3.00" [76.2 mm]
27910-22	High Contour	1.687" [42.8 mm]	2.5" [63.5 mm]
27910-23	High Contour	1.732" [44.0 mm]	3.00" [76.2 mm]
27910-24	High Contour	1.625" [41.3 mm]	2.75" [69.85 mm]
27910-25	High Contour	1.687" [42.8 mm]	2.5" [63.5 mm]
27910-27	High Contour	1.75" [44.45 mm]	2.5" [63.5 mm]
27910-28	High Contour	1.687" [42.8 mm]	2.25" [57.2 mm]
27910-29	High Contour	1.625" [41.3 mm]	2.25" [57.2 mm]
27910-30	High Contour	1.687" [42.8 mm]	2.25" [57.2 mm]

ULTRAFLO® Boot Assembly (Part No. 35580)

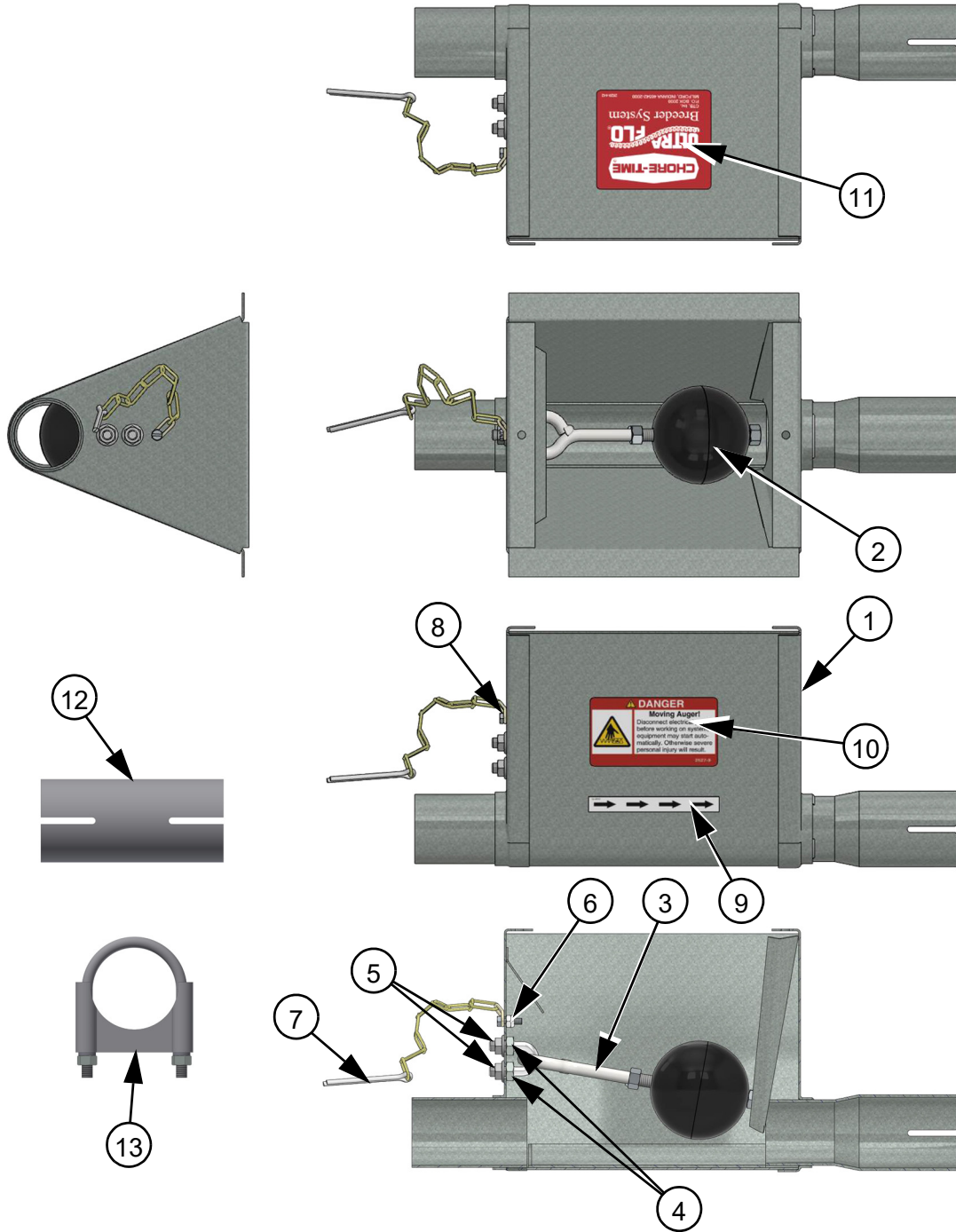

Item	Description	Part No.
1	Boot Weldment	35587
2	Agitator Assembly	46779
3	5/16-18 x .75 Bolt	34823
4	5/16-18 SS Hex Nut	2145-1
5	5/16-18 x Serrated Flange Nut	8490
6	10-24 Nylon Insert Lock Nut	34019
7	Latch Pin Assembly	2683

Item	Description	Part No.
8	10-24 x .625 HH Screw	1876
9	Posiflo Input Shaft Decal	2526-76
10	Danger Decal	2527-9
11	UltraPan Decal	2529-422
12	Connector Tube	29691
13	Tube Clamp Kit	29775

Power Unit and Driver Assembly

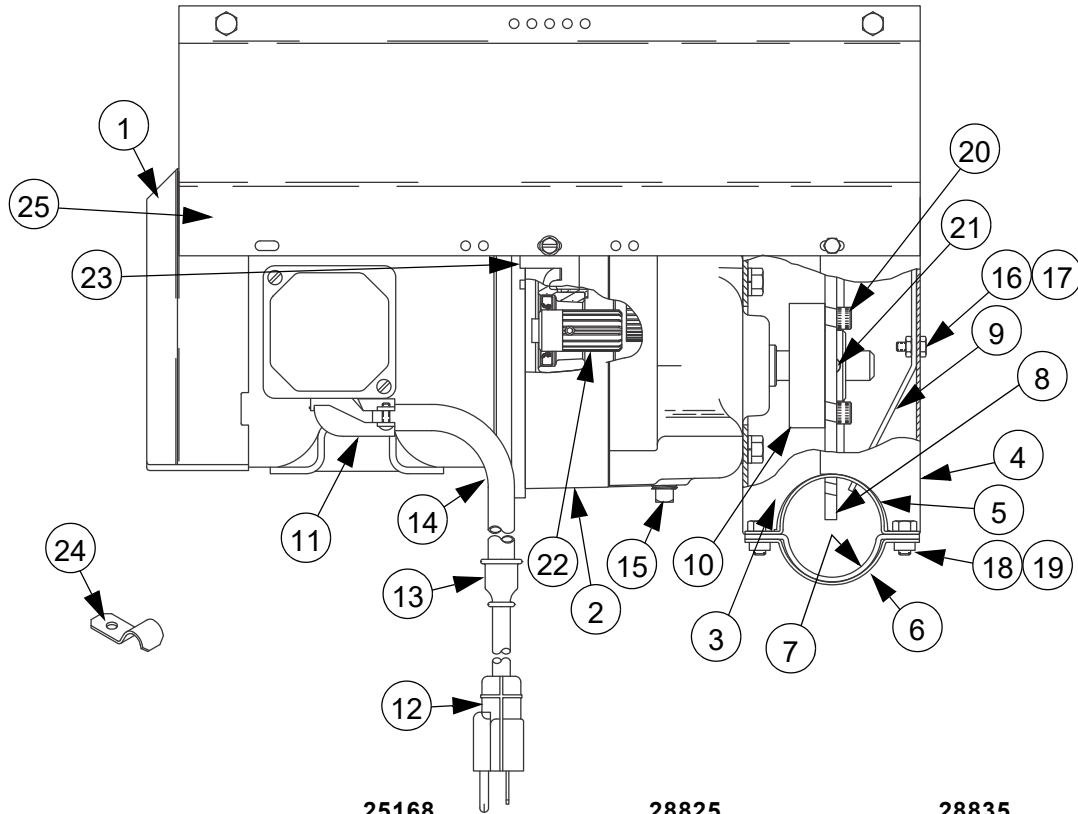

Item	Description	<u>25168</u>	<u>28825</u>	<u>28835</u>
1*	Motor	14733	28031EUR	14750
2	Gearhead Assembly	3261-21	3261-22	3261-22
3	Drive Unit Base	25292	25292	25292
4	Drive Unit Cover	25291	25291	25291
5	End Connector	25296	25296	25296
6	Base Connector Weldment	8249	8249	8249
7	Wear Shoe	25290	25290	25290
8	Drive Sprocket	25279	25279	25279
9	Auger Brace	24674	24674	24674
10	Drive Gear Hub	8213	8213	8213
11	90 Degree Connector	4228	- - - -	4228
12	Motor Cord Assembly	27719	- - - -	27719
13	Reducing Seal	7815	- - - -	7815
14	Vinyl Tubing	7814	- - - -	7814
15	Magnetic Pipe Plug	30160	30160	30160
16	10-24x1/2" Hex Head Screw	4416-3	4416-3	4416-3
17	10-24 Locknut	1560	1560	1560
18	1/4-20x1/2" Hex Head Screw	1487	1487	1487
19	1/4-20 Locknut	1269	1269	1269
20	5/16-18 Socket Head Cap Screw	6850-1	6850-1	6850-1
21	Dowel Pin	8699	8699	8699
22	Pinion Assembly	3249	25836	25836
23	Motor Support	34266	34266	34266
24	Power Cable Bracket	34268	34268	34268
25	Motor Shield Side	34267	34267	34267

Power Unit and Driver Assembly Part Numbers:

Part Number	HP	RPM	Phase	Hz	Voltage
25168*	1/3	62	Single	50/60	220/208-230V
28825*	1/3	61	Three	50/60	220/380V.
28835*	.4	61	Single	50/60	220/208-230V

WEIGH-MATIC® Model 90 Screener (Part No. 25432)

Item	Description	Part No.	The entire Weigh-Matic Model 90 Screener including:
1	Control Unit	46800-23	-25432 Screener (components shown),
2	Seal	4873	-4347 upper boot,
3	Cover Weldment Screener	25446	-9301 lower boot,
4	Clamp	6183	-6942-25 auger,
5	Screen	45922	-6293 10' auger tubes,
6	Extruded Plate	22084	-7357 90 degree elbows,
7	Anchor Tube	5069	-5790 Beam Box, and
8	Screen Retainer	24796	-3259-52 power unit
9	Sponge Tubing (6')	5928	may be ordered under part no. 25790.
10	Flexible Drop Tube	48032	
11	Drop Tube (not supplied w/Screener)	6381	
12§	Power Unit (not component of 25432)	3259-52	
13*	Agitator	25674	
14*	Driver Assembly	25705	
15**	Top Channel	25469	
16**	Corner Support	25470	
17**	Support Channel	25468	
18**	Foot Mount	25467	
19**	Channel Support Extension	35800	
20**	"U" Bolt	28874	
21	Control Anchor Weldment	47715	
--§	Junction Box Assembly	25694	
--	Screener Cover	25701	

*May be ordered as an assembly under Part No. 25704.

**May be ordered as an assembly under Part No. 25472.

§See individual parts.

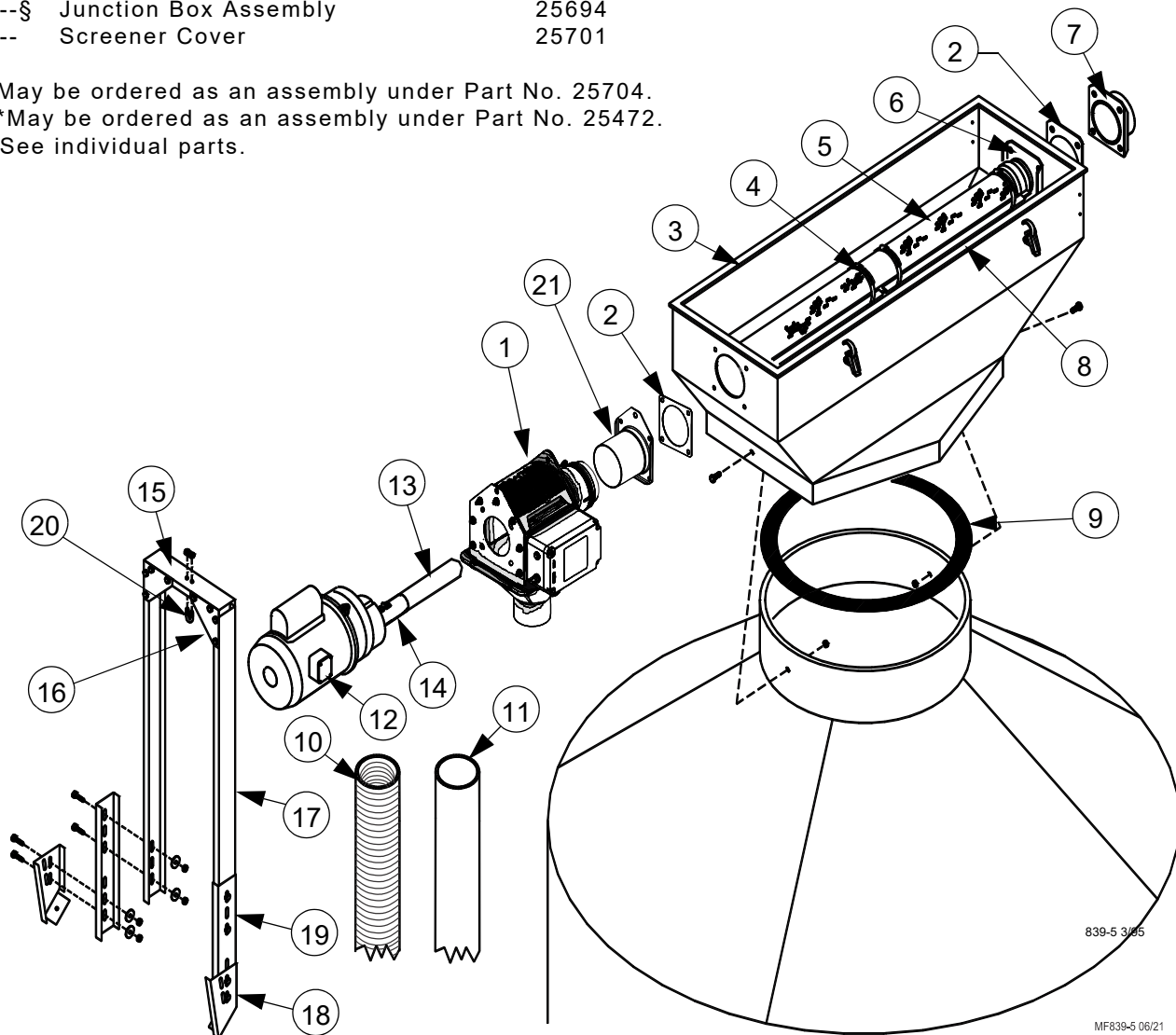

839-5 3/85

MF839-5 06/21

Screener Control Unit

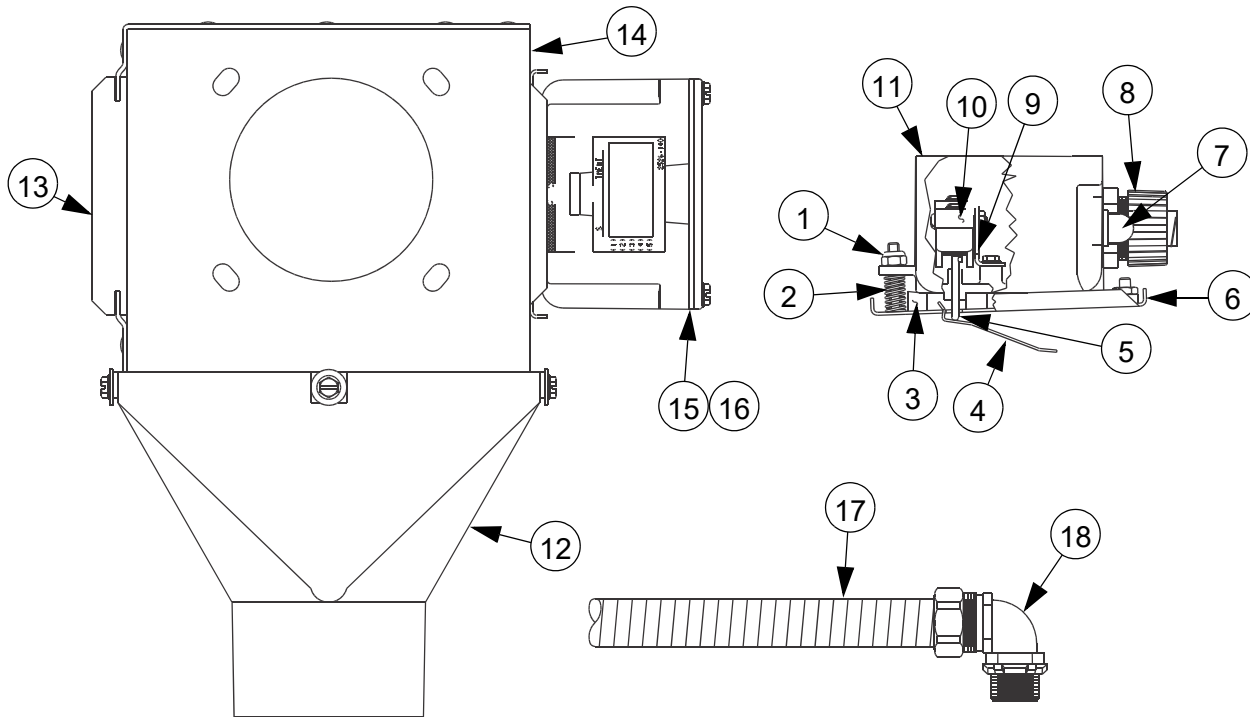

Item	Description	Part No.	Item	Description	Part No.
1*	10-32 Locknut	6963	14	Body Assembly	24268
2*	Spring	6972	15	Gasket	6777
3*	Gasket	6968-1	16	Switch Box Cover	6776
4*	Paddle	7896	17	1/2" Flexible Conduit	26982-9
5*	Pin	6775	18	Watertight Connector	23810
6*	Mounting Plate Assembly	7908	--	Diaphragm Assembly	7900
7*	Pilot Light Assembly	7044			
8*	1/2" Liquid Tight Fitting	26980			
9*	Switch Bracket	7068			
10*	SPDT Actuator Switch	7114			
11*	Switch Box	25696			
12	Drop	6091			
13	Slide	5073			

*These items may be ordered as an assembly under part-number 25697.

The complete Control Unit (including Driver Assembly and Junction Box Assembly) may be ordered under part no. 25720.

Junction Box Assembly (Part No. 25694)

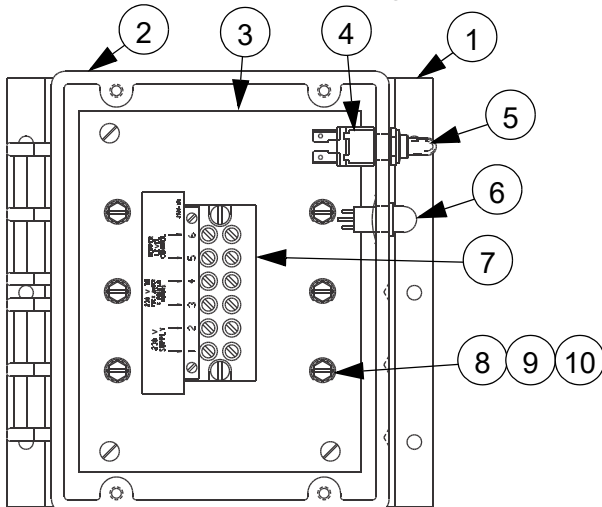

Shown with Cover Removed

Item	Description	Part No.
1	Junction Box Mount	25692
2	Junction Box (including cover)	25693
3	Mounting Panel	25691
4	Toggle Switch	7767
5	Toggle Switch Boot	13406
6	Pilot Light	7044
7	Terminal Block	8848
8	10-32 Ground Screw	4968
9	10 Ext. Lock Washer	305
10	Cup Washer	5775

Screener Control Unit 46800-23

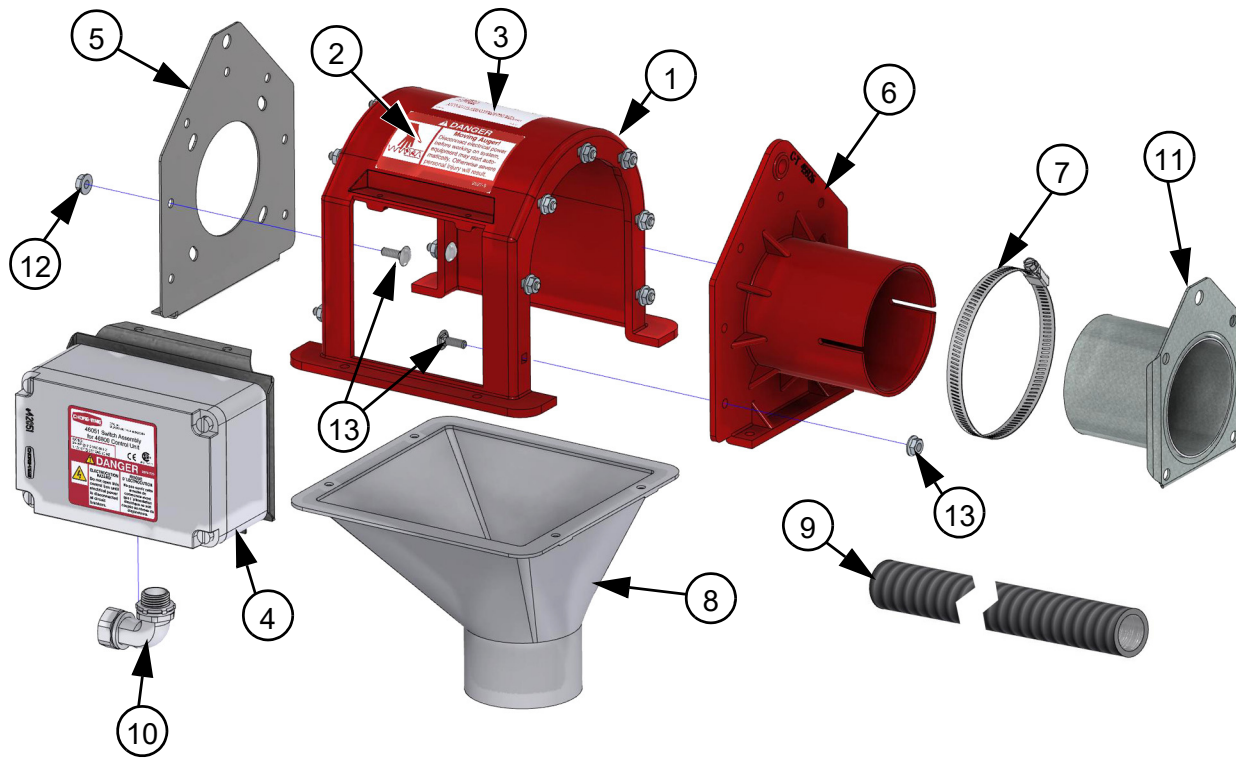

Item	Description	Part No.
1	Flex Auger Control Body	43601P
2	Moving Auger Decal	2527-9
3	Flex Auger Patent Decal	2528-15
4	Flex Auger Control Switch	46051F
5	Gearhead End Plate	43596
6	90 HMC Anchor Tube End	45926
7	Adjustable Clamp	47652-1
8	Control Unit Funnel	45943-2
9	1/2 x 22 Flex Conduit	26982-10
10	Liquid Tight Ell Connector	23810
11	(90) Control Anchor Weldment	47715
12*	1/4-20 Hex Flange Nut	46460
13*	1/4-20 x .75 Bolt	7550-2

*Included in 56562 Hardware Package

Screener Power Unit (50 and 60hz)

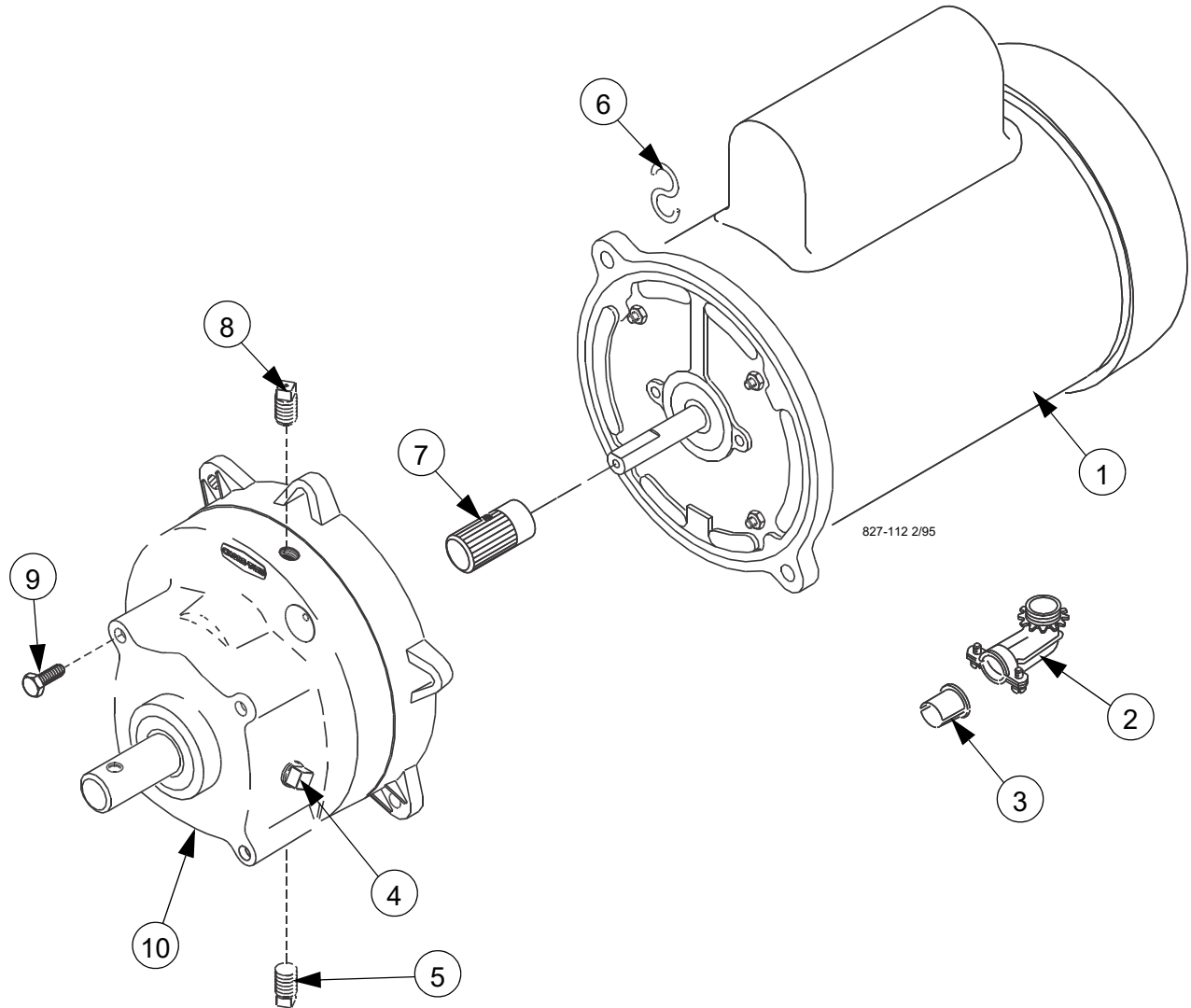

Screener Power Unit • 60 Hz.

Screener Power Unit • 50 Hz.

Key	Description	Part No.
1	Motor--3/4 HP, 230V.	5051
2	90 Degree Connector	4228
3	Anti-Short Bushing	6304
4	Pipe Plug	2755
5	Magnetic Pipe Plug	30160
6	"S" Hook	4270
7	Pinion Assembly	5046
8	Vent Plug	3523
9	5/16-18x5/8" Hx Hd M S	4412-1
10	Gearhead Assembly-348 RPM	3261-7

Key	Description	Part No.
1	Motor--3/4 HP, 220/380 V, 3 Phs.	28034
	Motor--3/4 HP, 220/380 V, 1 Phs.	6305
2	90 Degree Connector	----
3	Anti-Short Bushing	6304
4	Pipe Plug	2755
5	Magnetic Pipe Plug	30160
6	"S" Hook	4270
7	Pinion Assembly	5046
8	Vent Plug	3523
9	5/16-18x5/8" Hx Hd M S	4412-1
10	Gearhead Assembly-425 RPM	3261-10

Complete Power Units	Part No.
3/4 HP, 348 RPM Power Unit	3259-52

Complete Power Units	Part No.
3/4 HP, 348 RPM, 3 Phs Power Unit	3259-104
3/4 HP, 348 RPM, 1 Phs Power Unit	3259-88

Fill System Power Unit (50 and 60hz)

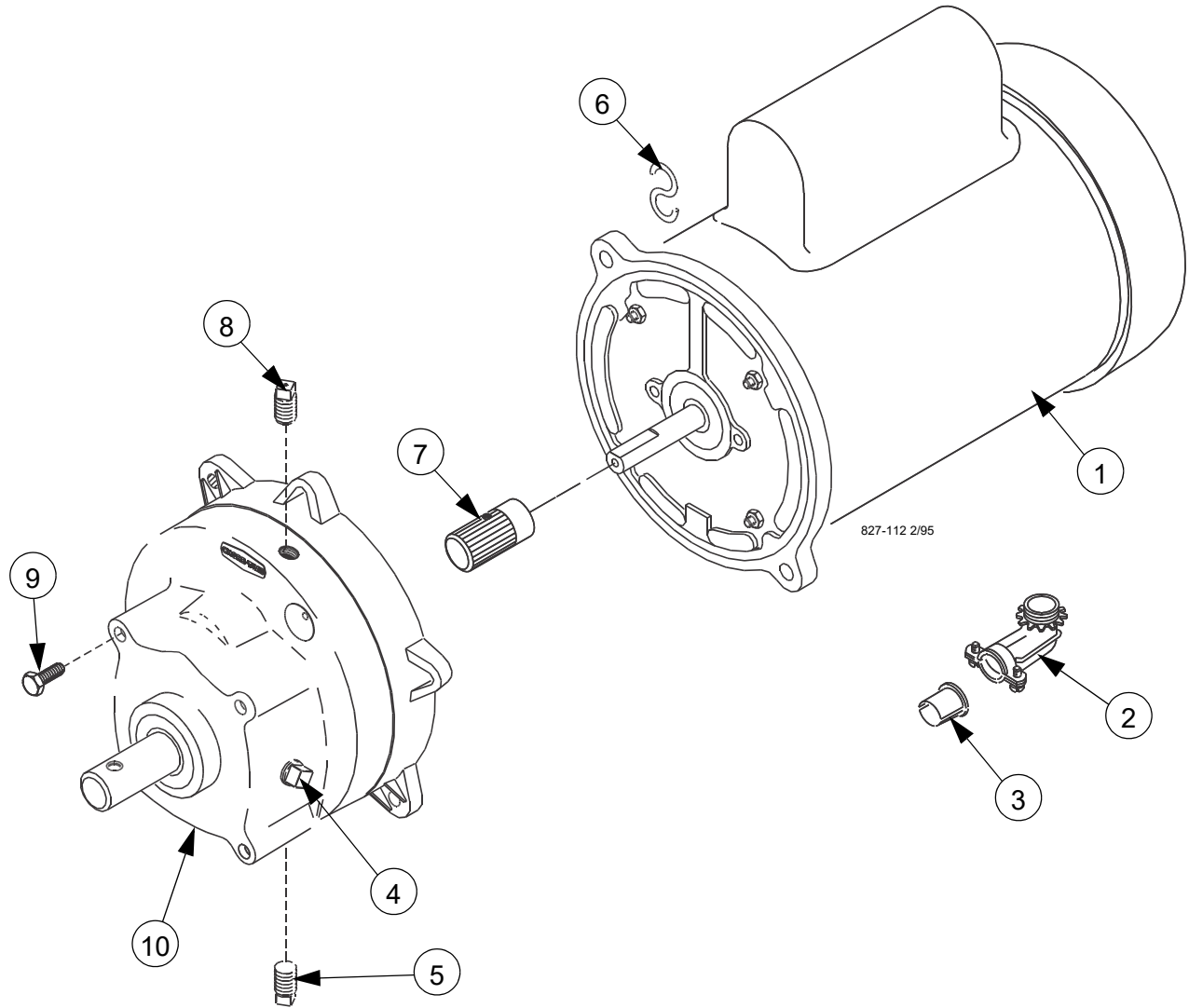

Fill System Power Unit • 60 Hz.

Fill System Power Unit • 50 Hz.

Key	Description	Part No.
1	Motor--1/2 HP / 230V. 3/4 HP / 230V. 1 HP / 220V.	5050 5051 6857
2	90 Degree Connector	4228
3	Anti-Short Bushing	6304
4	Pipe Plug	2755
5	Magnetic Pipe Plug	30160
6	"S" Hook	4270
7	Pinion Assembly - for 1/2 & 3/4 HP RPM Motors - for 1 HP Motors	5046 6104
8	Vent Plug	3523
9	5/16-18x5/8" Hx Hd M S	4412-1
10	Gearhead Assembly-425 RPM	3261-10
Complete Power Units		Part No.
1 HP, 425 RPM Power Unit		3259-79
1/2 HP, 425 RPM Power Unit		3259-77
3/4 HP, 425 RPM Power Unit		3259-78

Key	Description	Part No.
1	Motor--1 HP, 3-Phs, 220- 380 V, Motor--1 HP, Single Phs. 220 V,	28035 26157
2	90 Degree Connector	4288
3	Anti-Short Bushing	6304
4	Pipe Plug	2755
5	Magnetic Pipe Plug	30160
6	"S" Hook	4270
7	Pinion Assembly- for 1 HP Motors	6104
8	Vent Plug	3523
9	5/16-18x5/8" Hx Hd M S	4412-1
10	Gearhead Assembly-474 RPM	3261-13

Complete Power Units	Part No.
1 HP, 474 RPM, 3-Phs, 220-380 V.P.U.	3259-107
1 HP, 474 RPM, Single Phs, 220 V. P.U.	3259-108

Weigh Scale Assembly

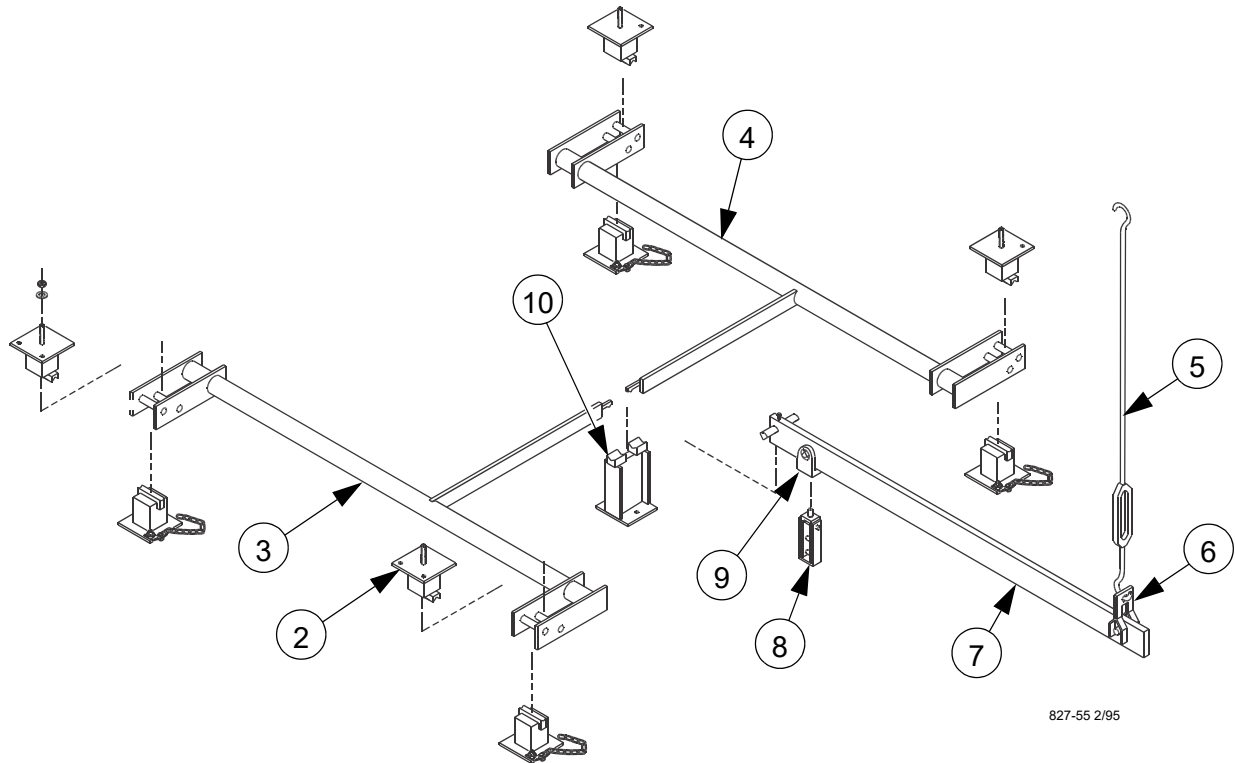

827-55 2/95

Item	Description	Part No.	
1	Lower Main Stand	7A	Complete 5,000 Lbs Bin Scale Assembly is Winslow Part No. CT1819.
2	Upper Main Stand Assembly	9A	
3	Left Main Lever Assembly	1AL	Complete 8,000 Lbs Bin Scale Assembly is Winslow Part No. CT6514.
4	Right Main Lever Assembly	1AR	
5	Steelyard Rod	25	The complete Bin Scale Components must be ordered through Winslow Scale Company, 25th and Haythorne, P.O. Box 1523, Terre Haute, IN 47808. Phone: 812/466-5265.
6	Tip Loop	15	
7	Transverse Lever Assembly	10A	
8	Shackle	19	
9	Load Loop	18	
10	Transverse Stand Assembly	21A	

5978 Scale Template Assembly

Key	Description	Part No.
1	Rear Plate	5984
2	Side Plate	5988
3	Beam Box Leg Plate	5986
4	Connector Plate	5985
5	Center Plate	5989
6	Front Plate	5987

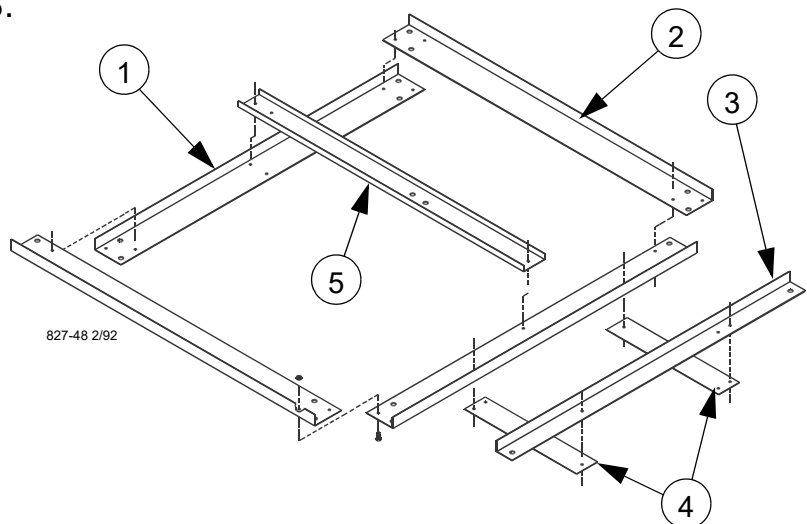

827-48 2/92

5790 Beam Box Assembly

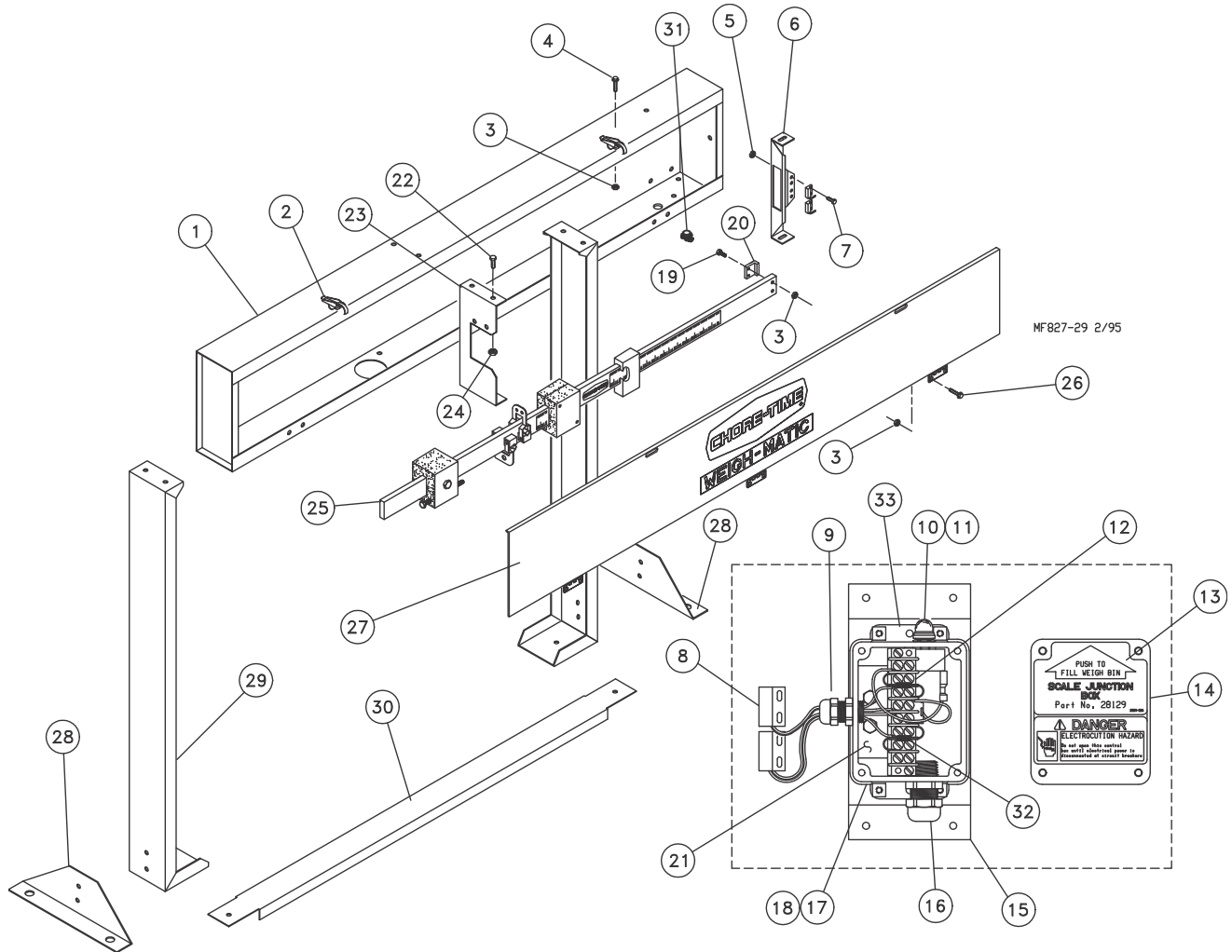

Item	Description	Part No.	Item	Description	Part No.
1	Case Weldment	5797	19	4-40 x 3/4" Rd. Hd. M.S.	4143-2
2	Over Center Clamp	2536	20	Magnetic Connector	5789
3	10-24 P.M. Nut	135	21	Terminal Mount	28599
4	10-24 x 3/8" Rd. Hd. M.S.	1553	22	3/8-16x3/4 HHCS	2182
5	4-40 Hex Nut	3511	23	Pivot Bracket	5803
6	Trig Loop	7472	24	3/8-16 Hex Nut	1549
7	4-40 x 5/8" Rd. Hd. M.S.	3510	25	Weighbeam Assembly	See Note Below
8	Proximity Sensor	6689	26	10-24x3/8 Truss Screw	501
9	Liquid Tight Connector	13477	27	Cover Weldment	5799
10	Momentary Switch	5785	28	Leg Support	5924
11	Push Button Boot	20784	29	Leg Weldment	5793
12	Terminal Strip	7270	30	Channel	7589
13	Terminal Box Decal	2529-326	31	Romex Connector	1317
14	Switch Box Cover	6776	32	Resistor	1709-19
15	Switch Mount Bracket	28247	33	Cover	6956
16	Water Tight Connector	23779			
17	Terminal Mount Box	28597			
18	Gasket	6777			

Note: The applicable Weighbeam Assembly must be ordered through: **Winslow Scale Company, 25th and Haythorne, P.O. Box 1523, Terre Haute, IN 47808. Phone: 812/466-5265.**

5,000 lbs. Weigh Beam Assembly (Part No. 9447)

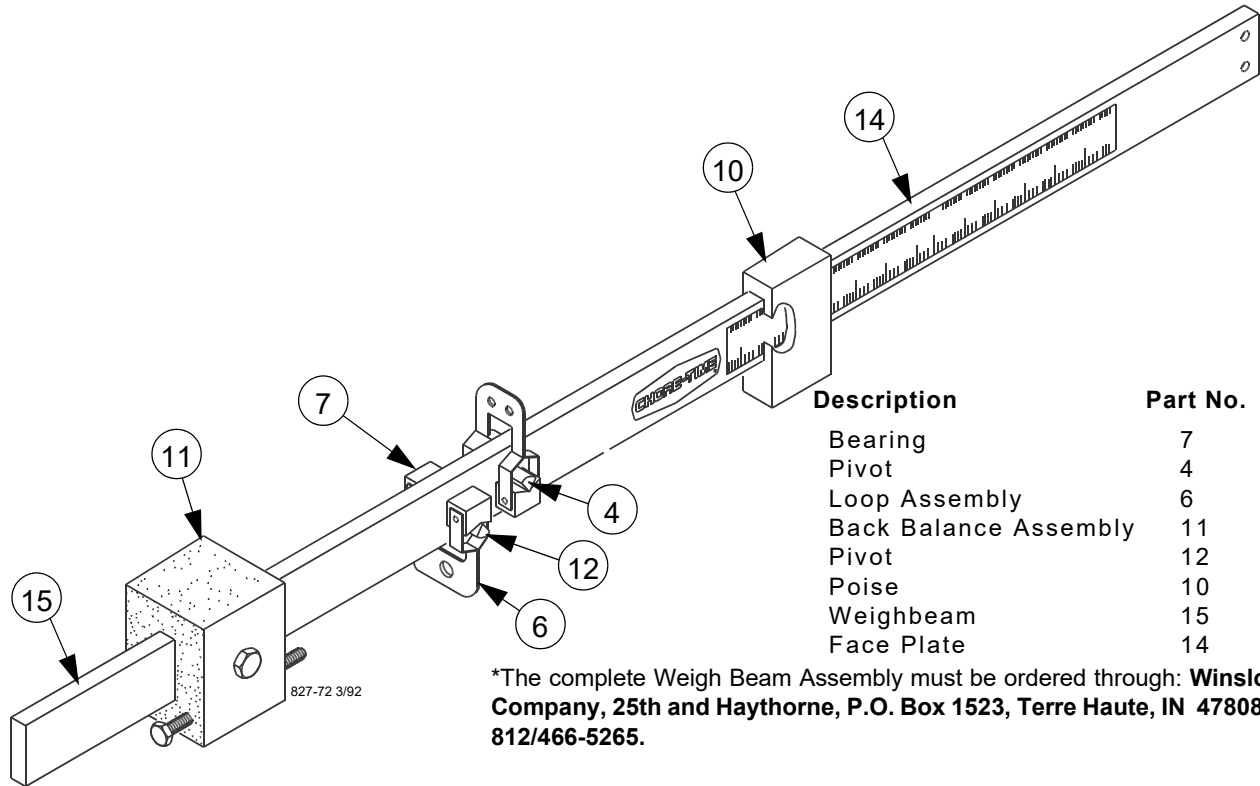

Description	Part No.
Bearing	7
Pivot	4
Loop Assembly	6
Back Balance Assembly	11
Pivot	12
Poise	10
Weighbeam	15
Face Plate	14

*The complete Weigh Beam Assembly must be ordered through: **Winslow Company, 25th and Haythorne, P.O. Box 1523, Terre Haute, IN 47808. PI 812/466-5265.**

8,000 lbs. Weigh Beam Assembly (Part No. 6514)

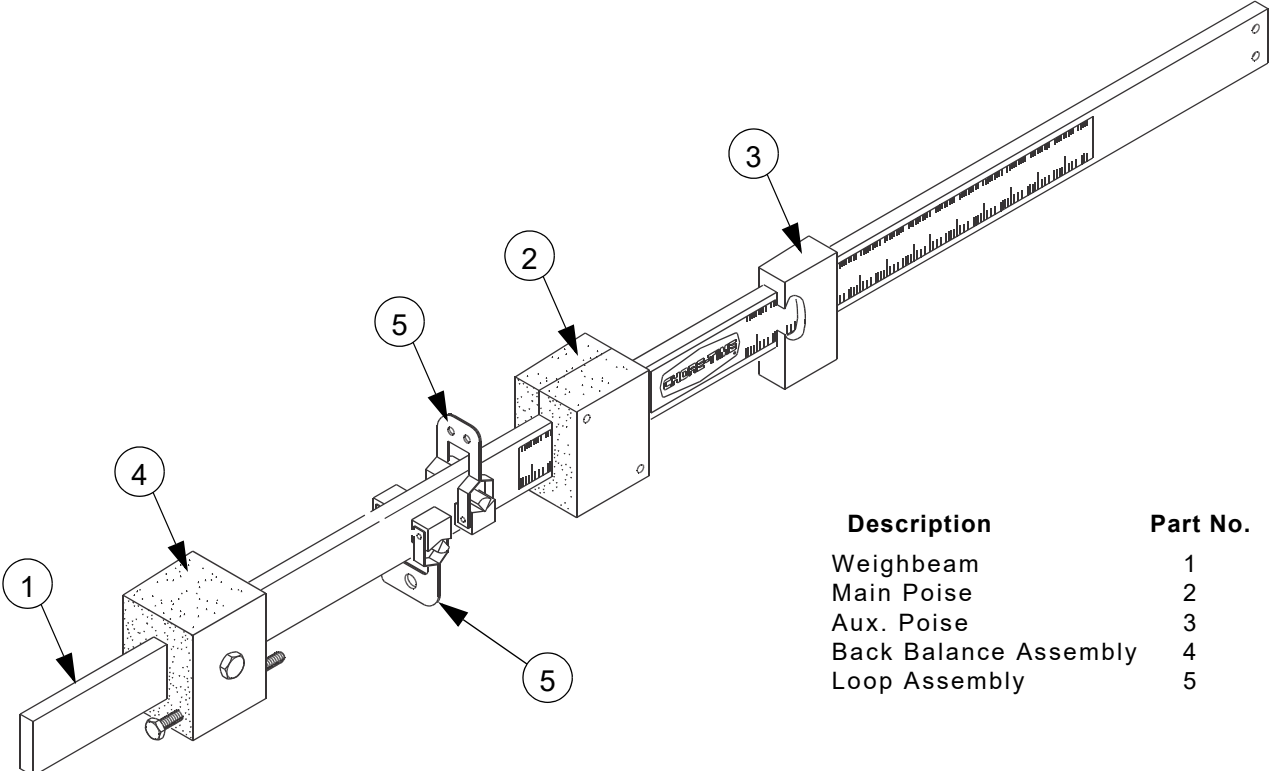

Description	Part No.
Weighbeam	1
Main Poise	2
Aux. Poise	3
Back Balance Assembly	4
Loop Assembly	5

*The complete Weigh Beam Assembly must be ordered through: **Winslow Scale Company, 25th and Haythorne, P.O. Box 1523, Terre Haute, IN 47808. Phone: 812/466-5265.**

Miscellaneous Suspension Components

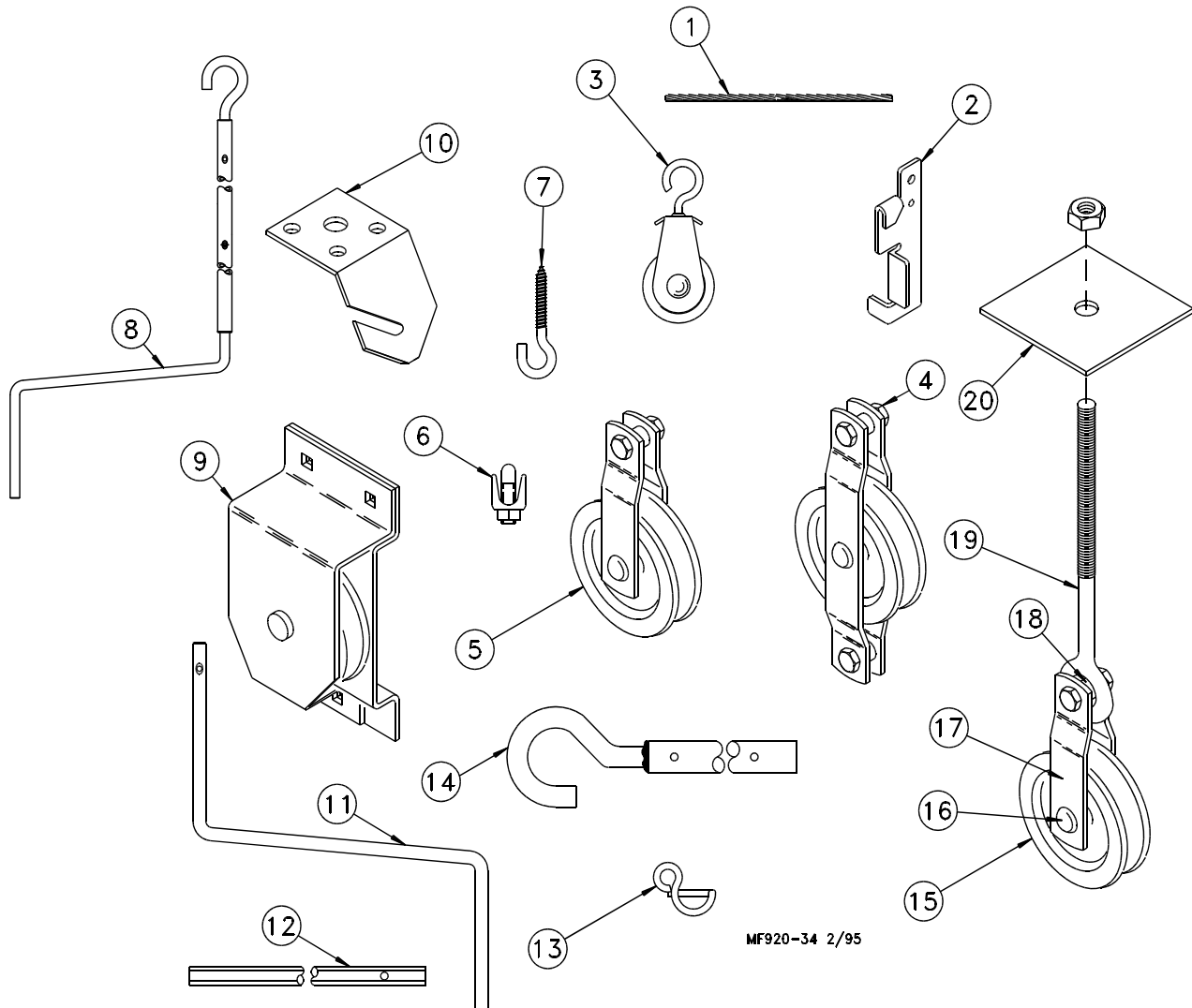

MF920-34 2/95

Item	Description	Part No.	Item	Description	Part No.
1	3/32" Cable (7x7)	4973	13	Winch Handle Pin	3761
	3/16 Cable (7x7)	1213	14	Winch Drive Tube (4')	2884-1
	1/8" Cable (7x7)	27975		Winch Drive Tube (8')	2884-2
2	Cable Lock	14337	15	Pulley	2503
3	Pulley with Swivel	3004	16	Clevis Pin	2498-1
4	Double Eye Pulley	2501	17	Side Bracket	2522
5	Pulley	2500	18	Spacer	2524
6	3/16" Cable Clamp	732	19	Eye Bolt	6362
	1/8" Cable Clamp	14898	20	Foot	1586
7	Standard Screw Hook	1214			
8	Telescoping Winch Handle	47638		Item 11 and Item 13 may be ordered as a kit	
9	Pulley Assembly	28429		under part no. 2885.	
10	Ceiling Bracket	28550			
11	Handle Shank	3148		Item 12 and Item 13 may be ordered as a kit	
12	Drill Adapter Shaft	3151		under part no. 2886.	

The Full Line Suspension Kit including items 15 through 20 and a 2809-2 Cable Assembly may be ordered under part no. 7948.

Clean-Out Assembly Kit (Part No. 35875)

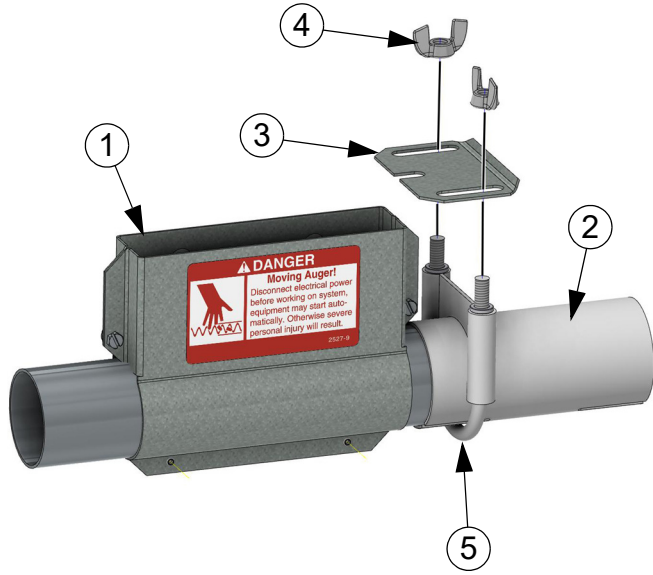

Item	Qty.	Description	Part No.
1	1	Clean-out	35802
2	1	Connector Tube	29691
3	1	Clean-out Lock	35865
4	2	Wing Nut	2146
5	1	Tube Clamp	29775

Winch (Part No. 47687)

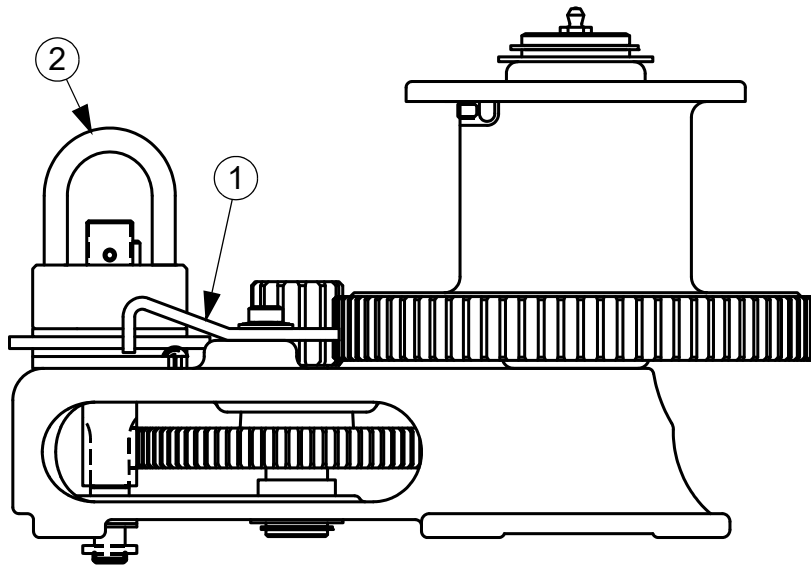

Item	Qty.	Description	Part No.
1	1	Pawl	47687-5
2	1	Input Shaft Assembly	47687-1

150# Hopper Components

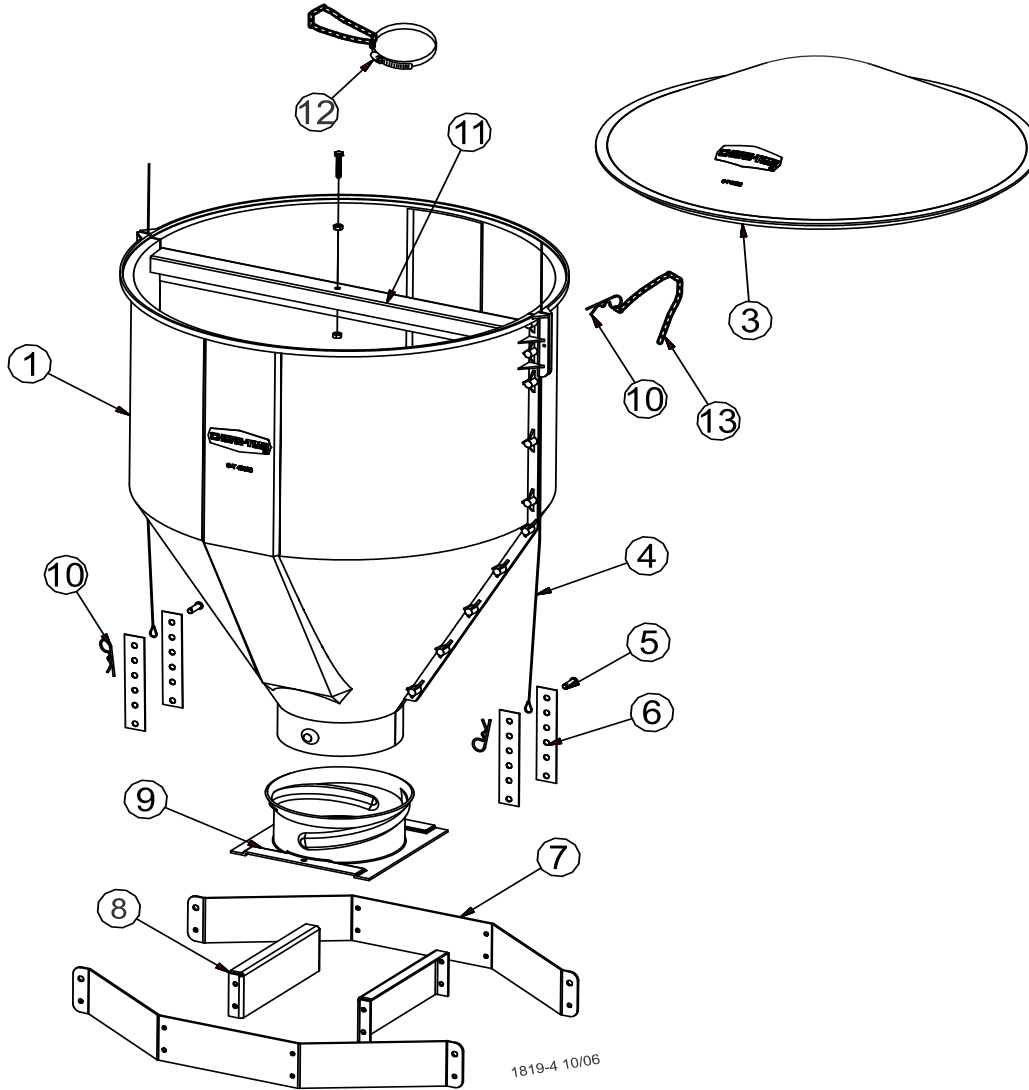

		Without Cover	With Cover
Item	Description	48926	49267
1	Hopper Half	49028	49028
2	--	--	--
3	Cover	--	48675
4	Cable Assembly	2809-3	2809-3
5	Clevis Pin	2797-1	2797-1
6	Adjustment Bracket	2706	2706
7	Suspension Angle	48679	48679
8	Suspension Brace	48680	48680
9	Twist Lock Collar	49041	49041
10	Hairpin	2664	2664
11	Brace	49029	49029
12	Tube Support Assembly	14367	14367
*13	Chain	2128	2128
*Item must be ordered in either 100 ft or 250 ft quantities, 2128-100 is 100 ft and 2128-250 is 250 ft.			

Troubleshooting

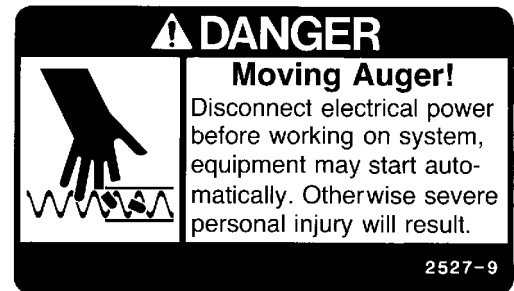
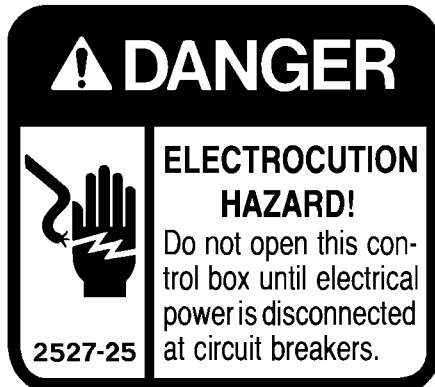

Problem #1: One loop not running, motors overloaded.

1. Auger stops because the feed level is too high (motors overloading).
 - A. Check to make sure that the auger running time is set correctly. The auger running time should be set for only 10 seconds more than the amount of time required for the auger to travel from one hopper to the next.
2. Check for foreign objects in the trough. Follow this procedure:
 - A. Reset the motors (push the overload button) and operate the feeder. If the feeder runs fine, the overload was caused by either high feed levels or a foreign object in the trough. (see item B, below).
 - B. If the feeder fails to operate, check the auger for foreign objects or water. The most likely place or object to jam is in the elbows or at a power unit. Foreign objects in the auger will cause the auger to become wedged and may be under pressure.
Using an Auger Puller or pliers, check both elbows and both power units.
CAUTION: Do not handle the auger by hand. Springing auger can cause severe personal injury.
 - C. Remove the object from the auger. If object is found at the power unit, check to make sure the auger was not damaged or distorted. Replace damaged section of auger.
 - D. If an object is not found, check other power units and elbows. It may be necessary to remove the power unit(s) from the trough and check to see if they operate properly. Replace if necessary.
 - E. If water is found in the trough, it may be necessary to help get the auger moving before the power units will take over.
 - F. Check screens in screeners for holes if source of foreign objects cannot be found.

Problem #2: One loop frequently overloads. When motors are reset, feeder runs fine for several minutes (days) before stopping. No foreign objects can be found.

1. Empty the feeder by opening the clean outs. Perhaps the problem is caused by a small object which will fall out with the feed.
2. Check the empty auger for a piece of metal wrapped around a flighting. Often these objects cannot be seen unless the auger is empty. Remove the foreign object.
CAUTION: Do not handle the auger by hand. Springing auger can cause severe personal injury.
3. Check the auger for stretched flightings or kinks. It may be necessary to remove auger from trough. Remove the damaged section(s) of auger and rejoin the auger. If one foot (300 mm) of auger or less is removed it may not be necessary to add a section of auger to replace damaged section.

Problem #3: Auger comes out of trough.

1. Damaged trough-repair or replace trough.
 - A. Often closing the grill further and installing the grill will close trough which has been spread open.
 - B. Close trough by installing trough retaining wire part no. 27909.
2. Missing grills-replace as needed.

Problem #4: One or more loops without feed.

1. Check drop tubes for plugging.
2. Check Intake Boots. Remove any foreign material, if present.
3. Check fill system control.
4. Check hoppers for bridging. If bridging is a problem, lower drop tubes.

Problem #5: Fill system motor overloads.

1. Check for objects in auger.
2. Remove auger, check for damage.

Problem #6: Screener

1. The screener bypass bucket should be checked daily.
 - A. If feed is in bucket, check screens for plugging.
 - B. If bucket does not contain normal amounts of whole corn or chunks of feed, check screens for holes.
2. Screener will not turn on.
 - A. Check operation at the switch on the side of screener control.

Maintenance

The ULTRAFLO Breeder Feeder requires minimum maintenance. However, a routine periodic inspection of the equipment will prevent unnecessary problems.

Maintenance should be done by a qualified technician.

ALWAYS DISCONNECT POWER TO THE SYSTEM WHEN SERVICING OR MAINTAINING THE EQUIPMENT. FAILURE TO DISCONNECT POWER MAY CAUSE INJURY OR DEATH.

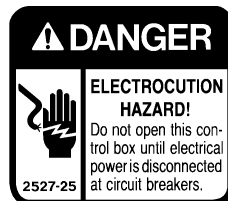

Each of the maintenance procedures should be done between each flock in addition to the intervals listed in the Maintenance Chart below.

Maintenance Schedule	Daily	Weekly	Three Months	Six Months	Between Flocks
Clean and Check Feeders	1				1
Clean Motor Areas				2	2
Check Feeder System Oil Level				3	
Clean Feed from Trough					5
Check Screener	6				6
Grease Bearings		7			7
Check Fill System Oil Levels		3			3
Clean Control Units				2	2
Clean Feed from Fill System					8

Match up the numbers in the chart with the maintenance notes below.

- 1 Check feeders to insure all lines have run. Check for foreign objects in the trough. Check feeders for loose hardware.
- 2 Remove dust and build up from around the motor areas to allow proper cooling of motors.
- 3 Check the oil level in the gear heads at installation and every 6 months. The Pipe Plug, on the side of the gear head, indicates proper oil level. Add SAE 40W oil when necessary.

The oil in the gear heads should be replaced every 12 months with new SAE 40W oil.

- A. Remove the bottom Pipe Plug to drain the oil. Discard used oil in accordance with local and national codes.
- B. Wipe any debris off the magnet on the bottom Pipe Plug and reinstall. Remove the side Pipe Plug and (top) Vent Plug.
- C. Set the power unit in the horizontal position.
- D. 2-Stage Gear Heads: Add approximately 9 oz. (266 ml) of SAE 40W oil through top hole. This should be just enough oil to reach the side Pipe Plug.

3-Stage Gear Heads (3261-9, 3261-12, 3261-14): Add approximately 13 oz. (384 ml) of SAE 40W oil through top hole. This should be just enough oil to reach the side Pipe Plug.

- E. Install the side Pipe Plug and (top) Vent Plug.
- 4 Remove feed from trough by opening clean-outs in feeder loop. Use caution while clean-outs are open, do not place fingers or foreign objects into clean-outs.
- 5 Check Screener output. Empty container if necessary.
- 6 Grease the bearings on the bin boots and feed screener. Chore-Time recommends using an industrial or automotive grease.
- 7 Close bin slide and allow fill system to empty.

Miscellaneous Maintenance Notes

- 1. If the system is not to be used for an extended period of time, remove all the feed from the auger lines and from the Feeder Trough.

Disconnect power to the system to prevent accidentally starting the system.

- 2. If the system must be disassembled, extreme caution must be used to prevent injury from springing auger.

- A. Disconnect power to the entire system.
- B. Use bolt cutters to cut the auger. Leave auger in trough when cutting.

CAUTION: Stand clear...the auger will spring to it's natural length.

- C. Remove the remaining system components in the opposite order they were installed, according to this manual.
- 3. Discard damaged or replaced equipment according to local and national codes. Many of the components may be recycled.
- 4. Replacing the battery in the Agri-Timer:
 - A. Disconnect electrical service at the breaker.
 - B. Remove the (6) screws and the face of the timer.
 - C. Replace the existing batteries with new "AAA" batteries.
 - D. Use new wire ties to secure the new batteries in place.
 - E. Reinstall the face of the timer and secure using (6) screws previously removed.
 - F. Reconnect electrical service to the system.

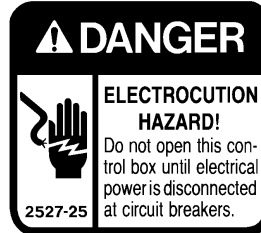

Component Weight Chart

Component	Weigh in pounds (kg)
Trough, Grill, Auger, & Feed	5 lbs. (2.26 kg.) linear foot (.3 m)
Power Unit & Driver Assembly	50 lbs. (22.6 kg)
150 lbs. Feed Hopper & Feed	200 lbs. (90.7 kg)
Power Winch	40 lbs. (18.1 kg)

Management Procedure for Day Old to End of Lay Applications

Use of the ULTRAFLO Breeder Feeder for day old through lay presents the possibility for problems during the rearing period. Careful management will be required to get uniform pullets.

Operation of the feeder during laying period is covered in the management section of this manual.

During the rearing period the following general steps apply:

1. For successful operation the ULTRAFLO Breeder Feeder should be operated for only enough time to get the feed in all the trough. (That is, the Run Timer should be set for only enough time to run the auger from one hopper to 10 feet (3 m) past the next hopper. After the entire loop has feed, the feeder should be stopped and the birds allowed to eat from the stopped auger. This cycle is called a 'serving'. Each feed day the feeder should run for 3 to 5 servings.
2. After one pass through a fully open intake Boot, the trough holds 1/2 pound of feed per foot (.75 kg of feed per meter of trough). Early in the rearing period the amount of feed to be fed each day may only fill part of the trough. Later in the rearing period the amount of feed to be fed may fill the trough once, but not fill all of the trough during the second serving.
3. For best results during the rearing period, the feeder needs to be run as soon as the trough is empty. The automatic time clock control will only allow servings every 20 minutes. During the rearing period, each of the 3 to 5 servings should be started manually. The Run Timer will stop the feeder

Note: During the laying period, the rate of consumption will be slower, so the time clock will control the feeder automatically.

4. Do not continue to run the feeder after all the trough has feed in it (as would be done with a chain feeder) as this forces the birds to eat from a moving auger.
5. If skip-a-day feeding is practiced, the first serving will have to be made with the feeder raised above the birds. In other words, fill the trough before lowering the feeder. The later serving can be made without raising the feeder. When lowering the feeder try to lower the feeder as fast as possible and lower both loops at the same time.
6. The ULTRAFLO Breeder Feeder will not feed pellets.
7. Feed trough clean outs can be located ahead of each hopper. If these clean outs are opened during the first serving, the trough will be cleaned prior to new feed entering the trough.

General Management Guide

1. 0-5 or 6 weeks
 - A. Pullets cannot be started on the ULTRAFLO Breeder Feeder.
 - B. Leave the ULTRAFLO feeder hanging above the birds.
 - C. Birds must be fed from the male line plus sufficient hanging feeders, or two lines of male feeders could be used.
2. 5 or 6 to 15 weeks
 - A. Use the ULTRAFLO.
 - B. Manually start the servings so that the next serving starts as soon as the trough is empty.
 - C. Run the feeder lowered to the birds unless skip a day feeding is used. If skip a day feeding is used, the first serving should be made with the feeder raised above the birds. The feeder should be left lower during subsequent feedings.
 - D. Leave the male lines hanging above the birds.
3. 15 to 22 weeks
 - A. Use the ULTRAFLO feeder and the male feeder(s).
 - B. It will be impossible to separate feed males until approximately 23 to 25 weeks, because male head size will be too small to be restricted by grill openings. However, by this time the birds will be large enough that extra feeding space will be required.
 - C. Feed flow baffles should be lowered (closed) to allow 3 to 5 servings per feeding cycle.
 - D. Manually start the servings so that the next serving starts as soon as the trough runs empty.
 - E. Run the feeder lowered to the birds unless skip a day feeding is used. If skip a day feeding is used, the first serving should be made with the feeder raised above the birds. The feeder should be left lower during subsequent feedings.
4. 22+ weeks
 - A. Use the ULTRAFLO feeder and the male feeder(s).
 - B. Start the male feeder 3 to 4 minutes before the ULTRAFLO feeder. Make sure the male pans are 17 to 18 inches (430 mm to 460 mm) above the litter to prevent the females from being able to reach the pan.
 - C. To Program the clock see “**Programming the 4-Channel Time Clock**” on page 46. The panel should be on automatic after the birds reach 22+ weeks of age.
 - D. Run the feeder lowed to bird level.

This page left blank intentionally.....

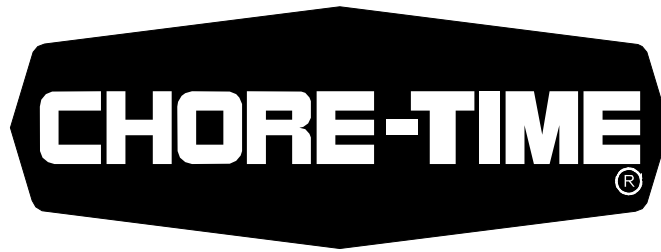

MADE TO WORK.

BUILT TO LAST.®

Revisions to this Manual

Page No.	Description of Change	ECO
75	Was 2883 Winch	35577
Various	Updated Graphics	

Contact your nearby Chore-Time distributor or representative for additional parts and information.

CTB, Inc.
PO Box 2000
Milford, Indiana 46542-2000 USA
Phone (574) 658-4101 Fax (877) 730-8825
Email: choretime@choretime.com
Internet: www.choretime.com