



# *Poultry Production Systems*

## **Pan Breeder Feeder**

### **and Male Feeder**

Installation and Operators manual

Installation and Operators Manual

Installation and Operators Manual

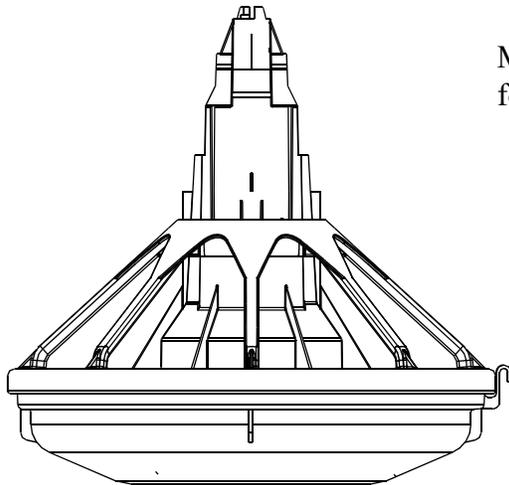

Model G Plus  
for Male Feeder

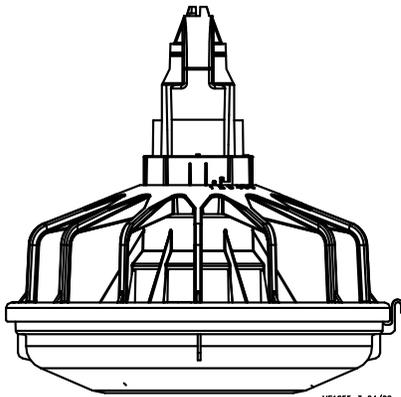
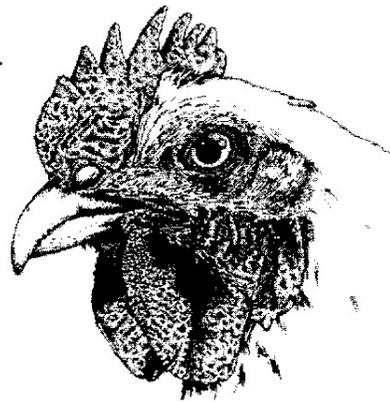

Model C2 Plus  
for Pan Breeder

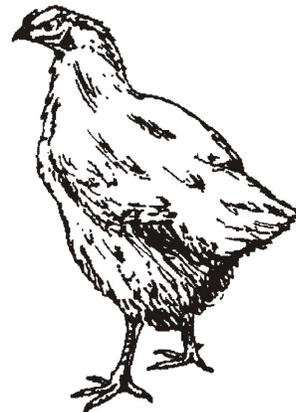

MF1255-3 04/02

## Chore-Time Warranty

CTB, Inc., (“Chore-Time”), warrants each new CHORE-TIME® product manufactured by it to be free from defects in material or workmanship for one-year from and after the date of initial installation by or for the original purchaser. If such a defect is found by Chore-Time to exist within the one-year period, Chore-Time will, at its option, (a) repair or replace such product free of charge, F.O.B. the factory of manufacture, or (b) refund to the original purchaser the original purchase price, in lieu of such repair or replacement. Labor costs associated with the replacement or repair of the product are not covered by the Manufacturer.

Additional extended warranties for the equipment and/or systems listed below are provided to the original purchaser as follows (for all other CHORE-TIME® products purchased, the one-year warranty period shall apply):

1. TURBO® and RLX™ fans, less motors - 3 years
2. TURBO® fan fiberglass housings, polyethylene cones, and cast aluminum blades - for the life of the product
3. TURBO® fan motors and bearings - 2 years
4. TURBO® fan components (including plastic shutters) - 3 years
5. Poultry feeder pans that becomes unusable within five years from the date of installation - Warranty prorated after three years usage
6. Rotating centerless augers, excluding applications involving high moisture feed stuffs (exceeding 18%), for ten years from the date of installation. Note: MULTIFLO® and applications involving high moisture feed stuffs are subject to a one-year warranty
7. Chore-Time manufactured roll-formed steel auger tubes for ten years from the date of installation
8. ULTRAFLO® Breeder Feeding System auger and feed trough are warranted for a period of five years from the date of original installation against repeated breakage of the auger or wear-through of the feed trough caused solely by the auger
9. ULTRAPAN® Feeding System augers are warranted for a period of five years from the date of installation against solely by the auger

## CONDITIONS AND LIMITATIONS

1. The product must be installed by and operated in accordance with the instructions published by the Manufacturer or Warranty will be void.
2. Warranty is void if all components of the system are not original equipment supplied by the Manufacturer.
3. This product must be purchased from and installed by an authorized distributor or certified representative thereof or the Warranty will be void.
4. Malfunctions or failure resulting from misuse, abuse, negligence, alteration, accident, or lack of proper maintenance shall not be considered defects under the Warranty.
5. This Warranty applies only to systems for the care of poultry and livestock. Other applications in industry or commerce are not covered by this Warranty.

Chore-Time shall not be liable for any consequential or special damage which any purchaser may suffer or claim to suffer as a result of any defect in the product. "Consequential" or special damages" as used herein include, but are not limited to, lost or damaged products or goods, costs of transportation, lost sales, lost orders, lost income, increased overhead, labor and incidental costs and operational inefficiencies.

THIS WARRANTY CONSTITUTES THE MANUFACTURER'S ENTIRE AND SOLE WARRANTY AND THIS MANUFACTURER EXPRESSLY DISCLAIMS ANY AND ALL OTHER WARRANTIES, INCLUDING, BUT NOT LIMITED TO, EXPRESS AND IMPLIED WARRANTIES AS TO MERCHANTABILITY, FITNESS FOR PARTICULAR PURPOSES SOLD AND DESCRIPTION OR QUALITY OF THE PRODUCT FURNISHED HEREUNDER.

Chore-Time Distributors are not authorized to modify or extend the terms and conditions of this Warranty in any manner or to offer or grant any other warranties for Chore-Time products in addition to those terms expressly stated above.

An officer of CTB, Inc. must authorize any exceptions to this Warranty in writing. Chore-Time reserves the right to change models and specifications at any time without notice or obligation to improve previous models.

Effective: **August 2004**

CTB, Inc.  
PO Box 2000  
Milford, Indiana 46542-2000 USA  
Phone (574) 658-4101  
Email: [choretime@choretime.com](mailto:choretime@choretime.com)  
Internet: [www.choretime.com](http://www.choretime.com)

### Thank You

The employees of Chore-Time would like to thank your for your recent Chore-Time purchase. If a problem should arise, your Chore-Time distributor can supply the necessary information to help you.

### **\*Chore-Time Poultry Feeder Pan Pro Rata Schedule**

Year from date of installation during which pan becomes unusable	Charge to be paid by the purchaser for replacement.
0 - 1 years	NO CHARGE
1 - 2 years	NO CHARGE
2 - 3 years	NO CHARGE
3 - 4 years	4/10 of then current list price
4 - 5 years	5/10 of then current list price

# Contents

Topic	Page
<b>Chore-Time Warranty</b> .....	<b>2</b>
<b>About This Manual</b> .....	<b>6</b>
<b>Safety Information</b> .....	<b>6</b>
<b>Safety Instructions</b> .....	<b>7</b>
Follow Safety Instructions .....	7
Decal Descriptions .....	7
DANGER: Moving Auger .....	7
DANGER: Electrical Hazard .....	7
CAUTION: .....	7
<b>General</b> .....	<b>7</b>
Information .....	7
Manufacturer's Recommendations: Birds per Pan .....	8
<b>Planning the Floor Feeding System</b> .....	<b>9</b>
<b>General Installation Information</b> .....	<b>10</b>
<b>Laying out the Suspension System</b> .....	<b>10</b>
<b>Installing the Suspension System</b> .....	<b>11</b>
Power Lift Winch Installation .....	11
Installing the Main Winch Cable .....	12
Screw Hook Installation .....	13
Ceiling Hook Installation .....	14
Steel Truss Installations .....	14
Steel Truss Welded Installations .....	14
Wood Truss Installations .....	14
Drop Installation .....	15
Power Winch Installation .....	16
Drop Installation .....	18
<b>Winch Control</b> .....	<b>19</b>
Installation .....	19
Operation .....	19
<b>Hopper Assembly Procedure</b> .....	<b>20</b>
<b>Feeder Assembly Procedure</b> .....	<b>22</b>
Assembly Box Construction .....	22
Pan Assembly Procedure .....	23
<b>Feeder Line Assembly &amp; Suspension</b> .....	<b>24</b>
Feeder Pan and Tube Assembly Process .....	24
Assemble and Suspend the Feeder Line .....	24
Indexing Chart for Pan Breeder Feeders .....	27
For Systems using 9' (2.7 m) Auger Tube and 696 RPM Power Units .....	27
For Systems using 12' (3.6 m) Auger Tube and 696 RPM Power Units .....	28
Indexing the Male Feeder .....	29
Indexing Chart for Male Feeders .....	30
For Systems using 9' (2.7 m) Auger Tube and 348 RPM Power Units .....	30
For Systems using 12' (3.6m) Auger Tube and 696 RPM Power Units .....	31
Model C2 Plus Feeder Lock Installation .....	32

# Contents - continued

Topic	Page
Installing the End Control, Boot Assembly, and Auger . . . . .	33
Auger Installation . . . . .	34
Auger Brazing . . . . .	38
Anti-Roost Installation . . . . .	39
<b>Feeder Management . . . . .</b>	<b>42</b>
<b>Maintenance . . . . .</b>	<b>43</b>
Floor Feeding System Maintenance . . . . .	43
Gear Head Maintenance . . . . .	43
Mechanical Switch Adjustment procedure for Control Units . . . . .	44
SENSOR PLUS Sensor Switch Adjustment for Control Units . . . . .	44
Feeder Line . . . . .	44
Power Lift Winch Maintenance . . . . .	45
<b>Trouble Shooting the Floor Feeding System . . . . .</b>	<b>46</b>
<b>Wiring Diagrams . . . . .</b>	<b>47</b>
Winch Control Wiring Diagram with 29820-3 Tower Limit Switch . . . . .	47
Winch Control Wiring Diagram with 39464 Limit Switch . . . . .	47
Male Feeder System Wiring Diagrams: Single Phase(Ø) . . . . .	48
Single Phase(Ø) Wiring Diagram . . . . .	48
Single Phase(Ø) Wiring Diagram: w/Motor Starter . . . . .	48
Male Feeder System Wiring Diagrams: Three Phase(Ø) . . . . .	49
Three Phase(Ø) Wiring Diagram: 220/230 V . . . . .	49
Three Phase(Ø) Wiring Diagram: 380/415 V . . . . .	49
Electric Power Lift Wiring Diagram . . . . .	50
<b>Parts Listing . . . . .</b>	<b>51</b>
Standard Breeder Pans . . . . .	51
Standard Breeder Pans with Shut-Off. . . . .	52
Shallow G™ Plus Breeder Pans with Slide Shut-Off. . . . .	53
Shallow G™ Plus Breeder Pans . . . . .	54
Shallow Breeder Pans . . . . .	55
34812 Winch Control Parts Listing . . . . .	56
14613 Switch Box Assembly . . . . .	56
8798 Switch Assembly . . . . .	57
Mechanical End Control . . . . .	58
Sensor Plus™ End Control . . . . .	60
Boot Assemblies . . . . .	62
Single: Part No. 6822. . . . .	62
Twin: Part No. 6824 . . . . .	62
Miscellaneous Suspension Components . . . . .	63
14580 Electric Winch Kit . . . . .	64
Feeder Line Components . . . . .	65
47687 Power Winch . . . . .	66
Indexing Gauge. . . . .	66
Power Unit Assemblies. . . . .	67

## About This Manual

The intent of this manual is to help you in two ways. One is to follow step-by-step in the order of assembly of your product. The other way is for easy reference if you have questions in a particular area.

**Important:** Read **ALL** instructions carefully before starting construction.

**Important:** Pay particular attention to all **SAFETY** information.

- *Metric measurements are shown in millimeters and in brackets, unless otherwise specified. “ ” equals inches and “ ’ ” equals feet in English measurements.*

*Examples:*

*1" [25.4]*

*4' [1 219]*

- Optional equipment contains necessary instructions for assembly or operation.
- Very small numbers near an illustration (*i.e.*, 1257-48) are identification of the graphic, not a part number.

## Safety Information

**Caution, Warning and Danger Decals** have been placed on the equipment to warn of potentially dangerous situations. Care should be taken to keep this information intact and easy to read at all times. Replace missing or damaged safety decals immediately.

Using the equipment for purposes other than specified in this manual may cause personal injury and/or damage to the equipment.

### Safety–Alert Symbol



**This is a safety–alert symbol.** When you see this symbol on your equipment, be alert to the potential for personal injury. This equipment is designed to be installed and operated as safely as possible...however, hazards do exist.

### Understanding Signal Words

**Signal words** are used in conjunction with the safety–alert symbol to identify the severity of the warning.



**DANGER** indicates an imminently hazardous situation which, if not avoided, **WILL** result in death or serious injury.



**WARNING** indicates a potentially hazardous situation which, if not avoided, **COULD** result in death or serious injury.



**CAUTION** indicates a hazardous situation which, if not avoided, **MAY** result in minor or moderate injury.

## Safety Instructions

### Follow Safety Instructions

Carefully read all safety messages in this manual and on your equipment safety signs. Follow recommended precautions and safe operating practices.

Keep safety signs in good condition. Replace missing or damaged safety signs.

### Decal Descriptions

#### **DANGER: Moving Auger**

This decal is placed on the Panel Weldment.

Severe personal injury will result, if the electrical power is not disconnected, prior to servicing the equipment.

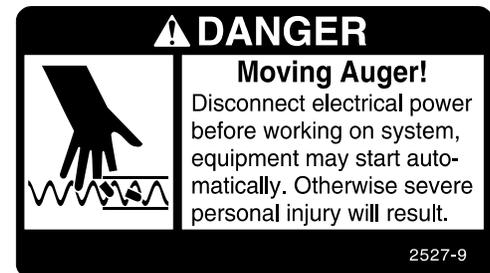

#### **DANGER: Electrical Hazard**

Disconnect electrical power before inspecting or servicing equipment unless maintenance instructions specifically state otherwise.

Ground all electrical equipment for safety.

All electrical wiring must be done by a qualified electrician in accordance with local and national electric codes.

Ground all non-current carrying metal parts to guard against electrical shock.

With the exception of motor overload protection, electrical disconnects and over current protection are not supplied with the equipment.

#### **CAUTION:**

Use caution when working with the Auger—springing Auger may cause personal injury.

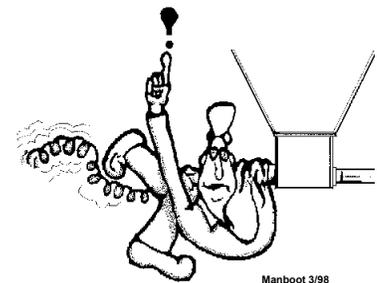

Manboot 3/98

## General

### Information

The Chore-Time Pan Breeder and Male Feeding System has been designed to feed poultry. Using this equipment for any other purpose or in a way not within the operating recommendations specified in this manual will void the warranty and may cause personal injury.

This manual is designed to provide comprehensive planning and installation information. The Table of Contents provides a convenient overview of the information in this manual.

## Manufacturer's Recommendations: Birds per Pan

Type	Max weight and/or weeks of age	Feeders	Number of birds/pan
Broiler	4.5lbs/2kg.	Revolution 12, Models C2 Plus, C2Plus S, C, H2, H2 Plus	60 - 90
Broiler	7lbs/3.1kg	Revolution 8, C2 Plus, C2 Plus S, G Plus, G Plus S, C, H2, H2 Plus	55 - 75
Broiler	9lbs/4.0kg	Revolution 8, G Plus, G Plus S	45 - 65
Broiler Breeder Pullet – rearing	0 – 18 weeks	C2 Plus (Breeder), C2 Plus S (Breeder)	14 - 15
Broiler Breeder Pullet – rearing	0 – 18 weeks Hi-Yield	C2 Plus (Breeder), C2 Plus S (Breeder)	12-14
Broiler Breeder Male – rearing	0 -- 18 weeks	C2 Plus (Breeder), C2 Plus S (Breeder), G Plus (Breeder), G Plus s (Breeder)	11-13
Broiler Breeder Layer	17 + weeks	C2 Plus (Breeder), C2 Plus S (Breeder)	13 - 14
Broiler Breeder Layer	17 + weeks Hi-Yield	C2 Plus (Breeder), C2 Plus S (Breeder)	12 - 13
Broiler Breeder Male	17 + weeks	G Plus (Breeder), G Plus S (Breeder)	8-10
Commercial Layer Pullet – rearing	0 – 20 weeks	Revolution 12, C2Plus, H2, H2 Plus	40-60
Commercial Layer	18 + weeks	Revolution 12, C2 Plus, C, H2, H2 Plus	30 - 40
Turkey Poult	0 – 5 weeks	Revolution 8, H2 Plus, H2, G Plus, G Plus S	60 - 65
Turkey Poult	0 – 10 weeks	Revolution 8, G Plus, H2 Plus, H2	40 - 50
Turkey Female	5 + weeks	ATF, ATF Plus	60
Turkey Male	5 + weeks	ATF Plus	40 - 50
Ducks	0 – 3 weeks	G Plus, G Plus S	60 - 70
Ducks	4 – 8 weeks	G Plus, G Plus S	50 - 60

**\*Notice:** Please be advised that the maximum number of birds that may be successfully produced per feed pan may vary based upon such factors as climate, housing type or style, bird breeds, genetic factors of the birds at issue, grower management practices, etc. All other environmental and management circumstances, such as proper bird density per house, access to adequate nutrients in feed, access to adequate water supply, proper ventilation, adequate health care for the birds, and other similar factors, must meet industry standards and recommendations, if any, of applicable bird breeder companies.

**\* NOTICE:** The above Manufacturer's recommendations do not constitute a product warranty and are in no way to be considered as a guarantee of performance for poultry production. In addition, the above information in no way alters or revises the terms and conditions of any applicable Chore-Time manufacturer's warranty.

# Planning the Floor Feeding System

## 1. Select the House Layout.

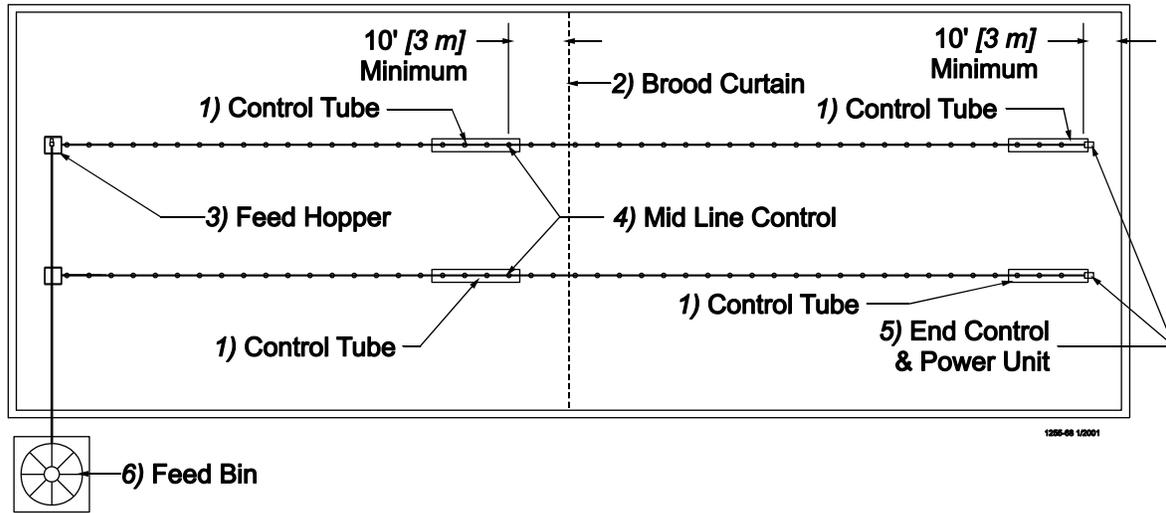

Figure 1. Component location diagram for systems up to 400 feet [122 m].

- A. Systems with line lengths over 400' [122 m] should be split in the center, as shown in Figure 2. This will reduce auger running time and eliminate the need for Mid-Line Controls for partial house brooding.

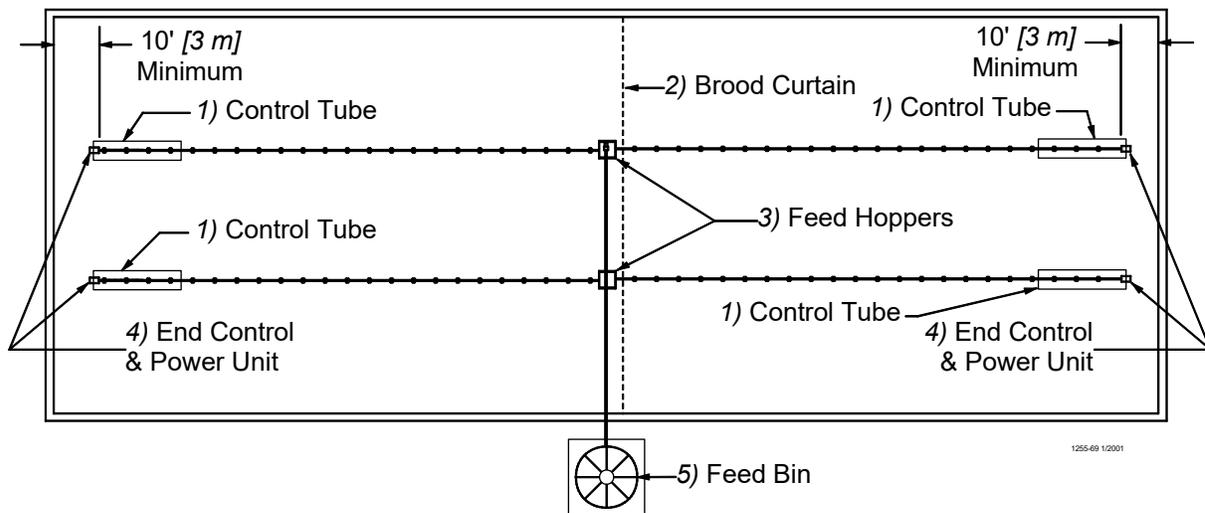

Figure 2. Component location diagram for systems over 400 feet [122 m].

2. Determine the Feed Bin location.
3. Determine the Brood Curtain location.
4. Determine the location for the End Control Pans. **The Feeder Control Pans should be at least 10' [3 m] from the Wall or Brood Curtain.**
5. Determine the distance to the Feeder Line from the Side Wall.
6. Determine the distance from the Feed Hoppers to the End Wall for a Straight Line Feeding System.

## General Installation Information

Please read the installation instructions in this manual prior to beginning the installation. This manual provides the necessary information on the installation, operation, and maintenance of the Chore-Time feeding equipment you have purchased.

The suspension, hopper assembly, feeder line installation, and anti-roost installation is the same for each system, except where noted otherwise. Please pay particularly close attention to insure proper assembly and installation of the equipment.

The Male Feeder use the Model G Plus breeder pan. The male feeder is available in nine foot 1 and 2 hole. The 9 foot tubes utilize the 348 rpm gearhead delivering 17# of feed per minute, also available is a 12 foot 3 hole feeder. The 12 foot feeder utilizes the 696 rpm gearhead delivering 35# of feed per minute.

The female feeder uses the Model C2 Plus breeder pan. The female feeder is available in 9 foot 4 hole and 12 foot 4 hole models using a 696 RPM. Gearhead, delivering approximately 35# per minute [10.6kg] per minute. All rating are based on feed with a density of 40 lbs per cubic foot [640 kg per cubic meter].

Single phase 60 Hz and single and three phase 50 Hz Power Units are available for the Model C2 Plus , G Plus Feeders.

## Laying out the Suspension System

1. Select the Suspension type.
  - A. For systems up to 350' [107 m]

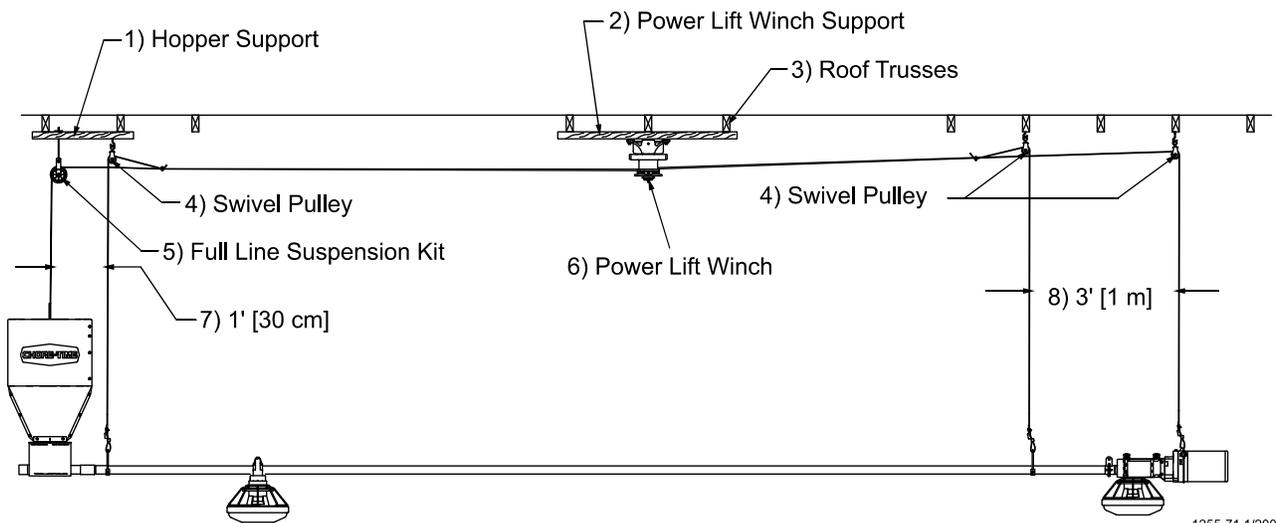

Figure 3. Suspension for systems up to 350' [107 m]

B. For systems over 350' [107 m]

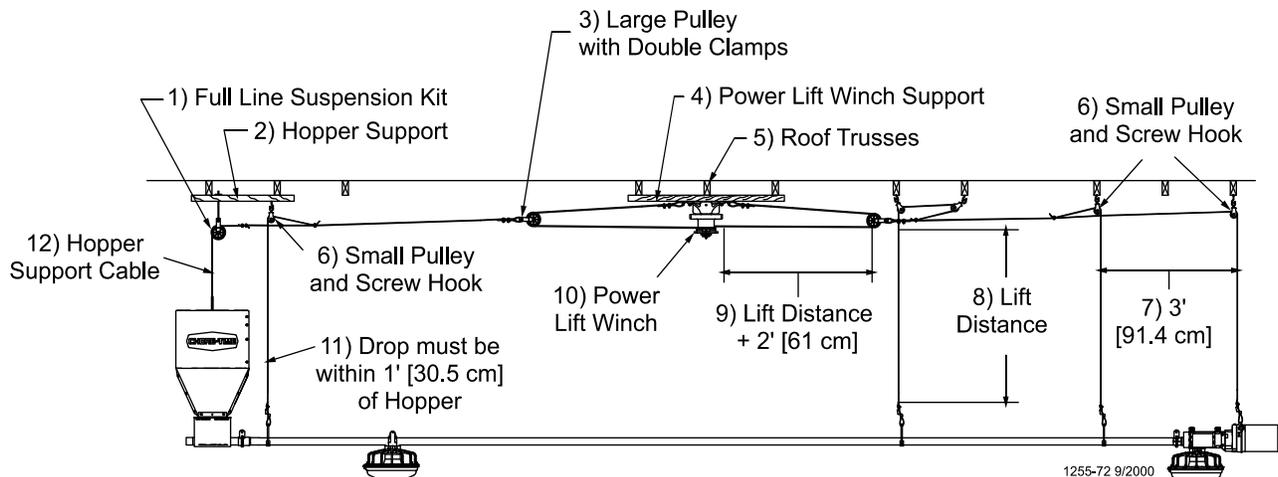

Figure 4. Suspension for systems over 350' [107 m]

2. Locate the Power Lift Winch. The Power Lift Winch requires a support that will span, in a wood frame house at least 3 rafters, and in a steel frame house at least 2 rafters.
3. Locate the Power Unit and Feed Hopper. Special support is required at each Power Unit and Feed Hopper location.
4. Determine the Drop Location and length. Suspension systems are based on ceiling heights of 14' [4.3 m] with suspension drop points every 8' [2.4 m]. DO NOT EXCEED 10' [3 m] BETWEEN SUSPENSION DROPS.
5. Determine the location for Screw Hooks. Mark a straight line or use cable to locate Screw Hooks. Use the offset of Screw Hooks where necessary.

## Installing the Suspension System

### Power Lift Winch Installation

1. Bolt the Power Winch, fully assembled, to the Power Lift Winch Support, either a 2" x 8" [50x200 mm] board that will span at least 3 rafters or a 3/8" [9.5 mm] thick steel plate welded to two pieces angle iron that are each long enough to span at least 2 rafters, using 5/16-18 hardware supplied in the Hardware Package. The brake mechanism will extend toward one side.

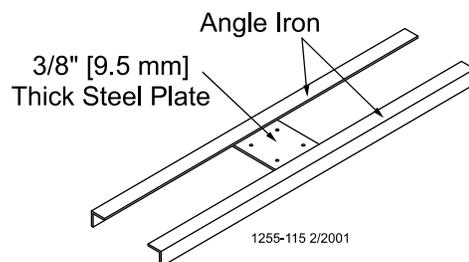

Figure 5. Optional Power Lift Winch support detail

Install a Cable Hook, supplied in Hardware Package, between the mounting bolt and Power Winch frame, as shown in **Figure 6**.

2. Attach the Power Lift Winch Support (with the Power Winch secured) to the ceiling at the center of the feeder line. See **Figure 7**. The Power Lift Winch Support must be parallel to the feeder line and must span at least 3 rafters in a wood frame house and 2 rafters in a steel frame house.

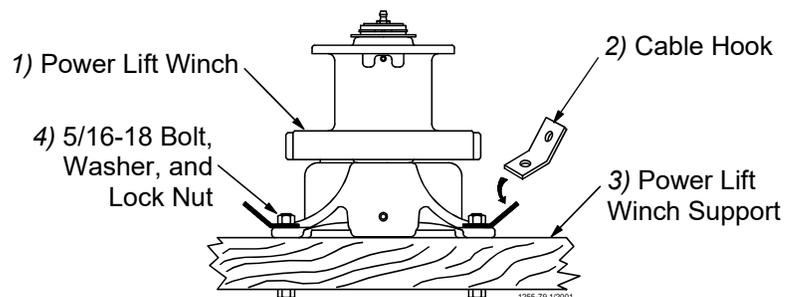

Figure 6. Assembling the Power Winch to the Rafters

If the hopper is located at the center of the feeder line, locate the Power Winch a few feet offset from the center of the feeder line. However, the Winch Drum must be directly in line with where the main cable is to be installed.

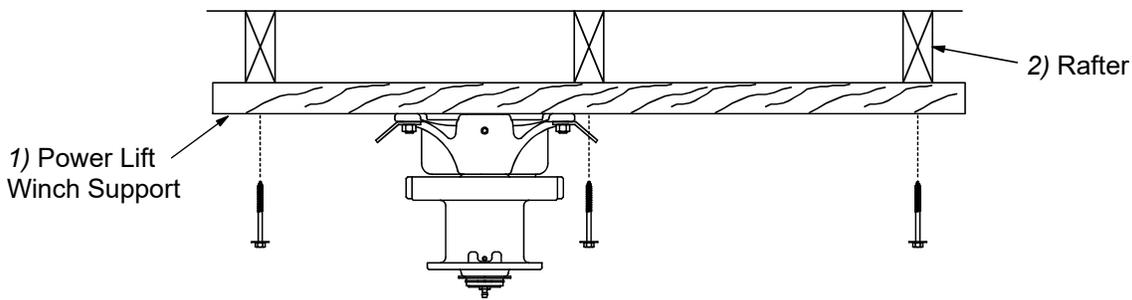

Figure 7. Mounting the Power Lift Winch and Support to the Rafters

### Installing the Main Winch Cable

The Suspension Systems are based on ceiling heights of 14' [4.3 m] with Suspension Drop points every 8' [2.4 m]. DO NOT EXCEED 10' [3 m] BETWEEN SUSPENSION DROPS. Refer to suspension section in this manual for installation details.

Adequate overhead structure must be provided to support the weight of the feeders, hoppers, power units, etc. The Suspension System is the same for the Model C2 Plus and G Plus Feeders. The type of installation required depends on the feeder line length.

#### IMPORTANT: Special support is required at each Hopper location.

- Power Unit Locations: **The Feeder Line must be supported within 3' [.9 m] of the Power Unit.** This is in addition to the required Power Unit suspension. If the Control Unit or Hopper does not come out directly under a truss, fasten a pulley to a 2" x 8" [50 x 200 mm] board or steel angle that will span 2 trusses and is capable of supporting 300 lbs [136 kg] for the Hopper and 75 lbs [34 kg] for the Control Unit.

- Feed Hopper Locations: **The Feeder Line must be supported within 1' [30 cm] of the Feed Hopper.** This is in addition to the required Feeder Hopper suspension. After determining the type of suspension system required, decide where the Feeder Line is to be installed. Mark a straight line on the ceiling or rafters the full length of the Feeder Line. Use a string, chalk line, or the winch cable, temporarily attached with staples, to mark the line. Center the line directly over where the Feeder Line is to be installed.

3. Extend the 3/16" [5 mm] Main Winch Cable the full length of the feeder line. Attach the cable temporarily to the ceiling with nails, staples, or some type of fasteners. **Figure 9.** shows a double back arrangement for feed lines over 350' [107 m].

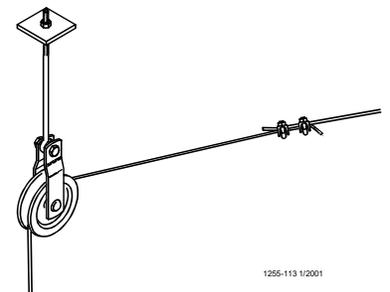

Figure 8. Full Line Suspension Kit

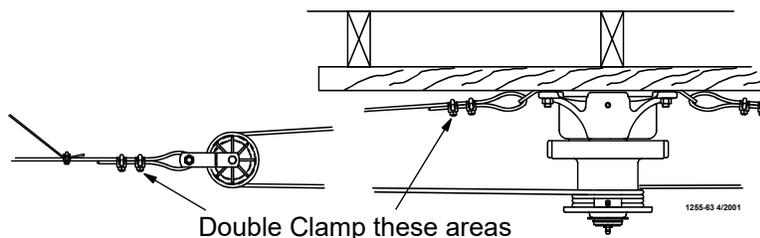
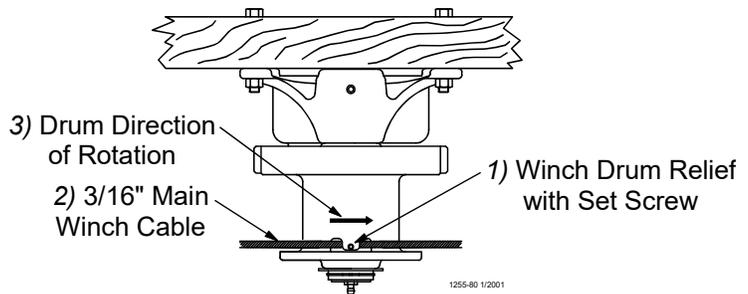

Figure 9. Double back arrangement for feed lines over 350' [107 m]

- Route the cable through the Winch Drum Relief located near the bottom of the drum. Tighten the set screw to anchor the cable to the drum. See **Figure 10**.



**Figure 10. Attaching the Cable to the Power Winch**

- Turn the winch drum one full revolution. Guide the cable against the flange at the bottom of the winch drum. The cable must not wrap over itself on the drum, but should be wrapped as close as possible to each previous wrap. See **Figure 11**.

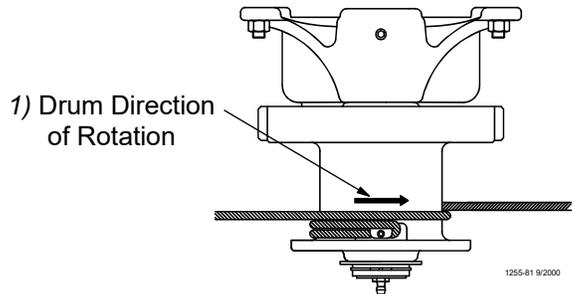
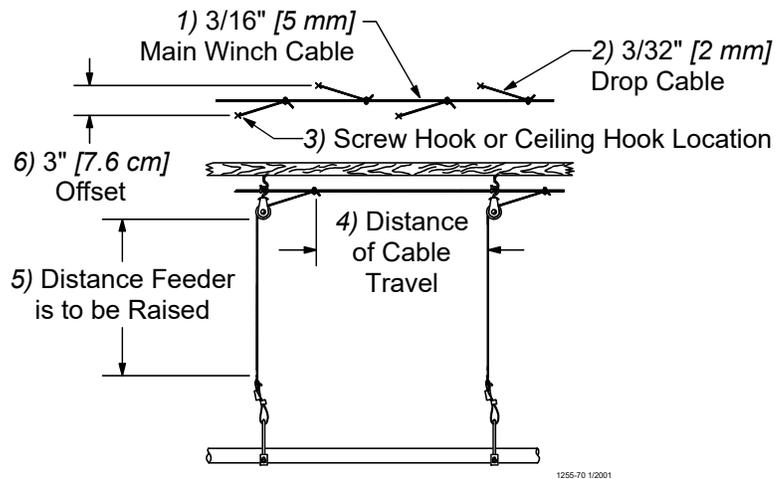

**Figure 11. Power Winch Drum Rotation**

### Screw Hook Installation

The recommended distance between the drops for the Model C2 Plus & G Plus is 8' [2.4 m] on center. Do not exceed 10' [3 m] spacing on drop lines.

If the distance raised is greater than the distance between the drop spacings, offset the hooks 3" [7.6 cm] to each side of the line to prevent the cable clamps from catching the pulleys. See **Figure 12**.



**Figure 12. Drop Line Off Set Detail**

Screw the hook into the truss the full length of the threads to prevent bending.

The openings of the screw hooks must be pointed away from the direction of travel when the Power Winch raises the feeder line. See **Figure 13**.

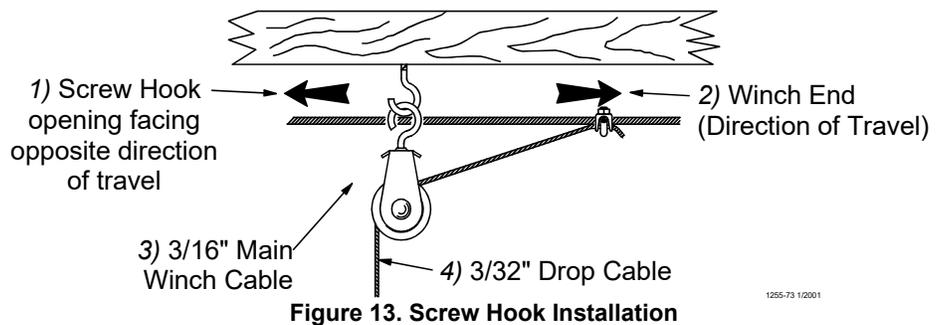

**Figure 13. Screw Hook Installation**

## Ceiling Hook Installation

The ceiling hook may be used in a variety of installations. Depending on your ceiling or rafter type, install the Ceiling Hooks as shown.

### Steel Truss Installations

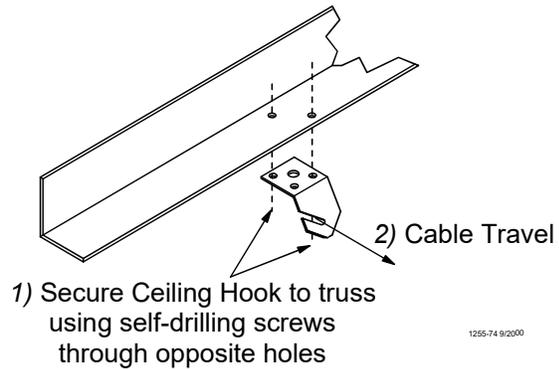

Figure 14. Steel Truss Ceiling Bracket Installation

### Steel Truss Welded Installations

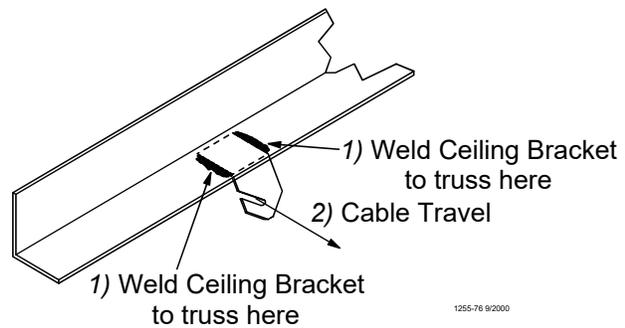

Figure 15. Welded Steel Truss Ceiling Bracket Installation

### Wood Truss Installations

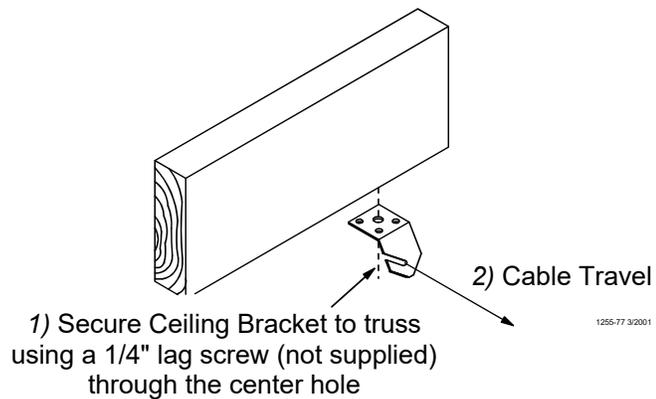

Figure 16. Wood Truss Ceiling Bracket Installation

- After securing the Ceiling Hook to the truss, slide the hook of a Swivel Pulley into the slot, as shown in **Figure 17**.

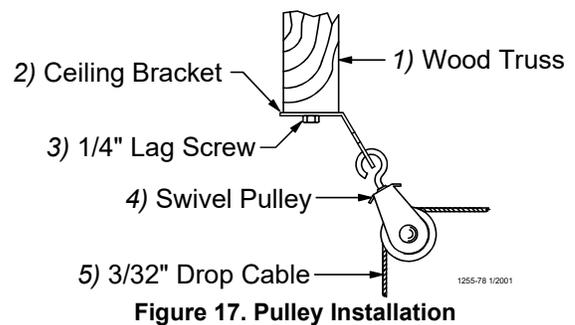

Figure 17. Pulley Installation

## Drop Installation

Refer to **Figure 12.** on page 13.

1. Attach a 3004 Pulley to each hook.
2. Thread the end of the 3/32" or 1/8" cable through the pulley toward the winch. Clamp this end to the 3/16" winch cable about 6" [150 mm] from the last pulley, using a 3/16" cable clamp. See applicable figure; **Figure 13.** or **Figure 17.**
3. Allow enough cable length for installation of the Adjustment Leveler.

Sufficient cable is included to provide "throwbacks" on drops located beneath and near the winch. **Figure 18.** shows a "throwback" cable arrangement.

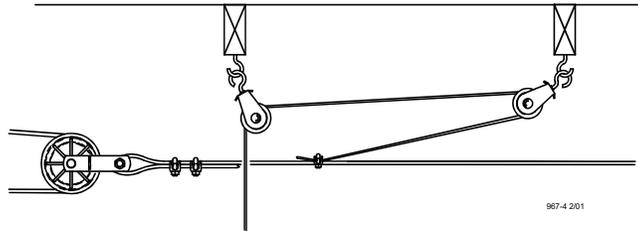

**Figure 18. "Throwback" cable arrangement**

4. **Begin installing suspension drops at the winch and proceed to the ends of the feeder line.**  
Keep the main cable tight between drops. It may be necessary to hang a weight on the end of the cable to maintain tension on the line.

## Power Winch Installation

When the 2883 Power Winch is used as an electric winch, the Input Shaft Assembly must be changed, as shown in Figure 19.

**Note:** If the Winch has already been installed, make sure there is no load on the Winch before attempting to change the Input Shaft Assembly.

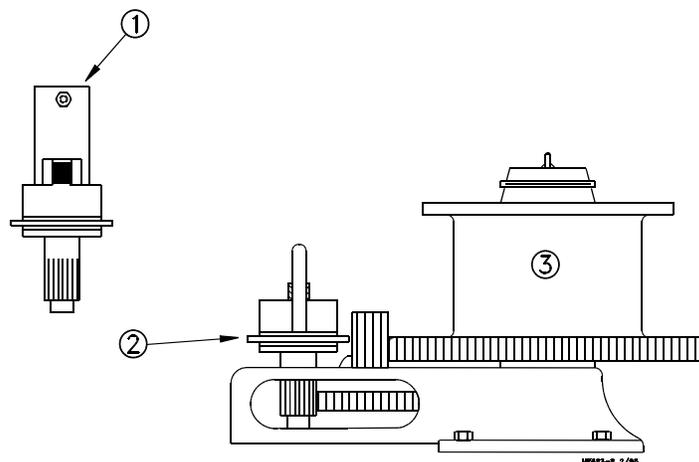

Item	Description
1	Install Input Shaft in place of existing Input Shaft shipped with the winch.
2	Remove this Input Shaft. Discard according to local and national Codes.
3	Winch

**Figure 19. Updating Input Shaft (Side View)**

The winch must be located in the center of the feeder line so that there is equal pull from both directions.

**NOTE:** If the Power Winch is to be located at the end of the feeder line, do not use the 24401 Winch Bracket. For end mounted installations, secure the Winch directly to the two 2 x 6's (50 x 150 mm) specified in step #1, below.

1. Use two 5/16-18x2-1/2" bolts on the front and each side of the bracket to mount the Winch Bracket to two 2 x 6's (50 x 150 mm) that will span at least three trusses as shown in **Figure 20**.
2. Lift the boards, with the Bracket attached, into position and secure to framing members on the ceiling.

If the hopper is located at the center of the feeder line, locate the Power Winch a few feet offset from the center of the feeder line. However, the Winch Drum must be directly in line with where the main cable is to be installed.

3. Bolt the Power Winch to the Winch Brackets using 3/8" hardware provided.

If the system is to be over 350' (107 m), install the Cable Hooks (supplied in Hardware Package) between the mounting bolt and Power Winch frame, as shown in **Figure 20**.

4. Use a 1/4" Socket Hd. Screw and 1/4" locknut to attach the Heavy Duty Input Shaft to the Power Unit Shaft as in **Figure 20**.
5. Bolt the Power Unit to the Power Unit Bracket.

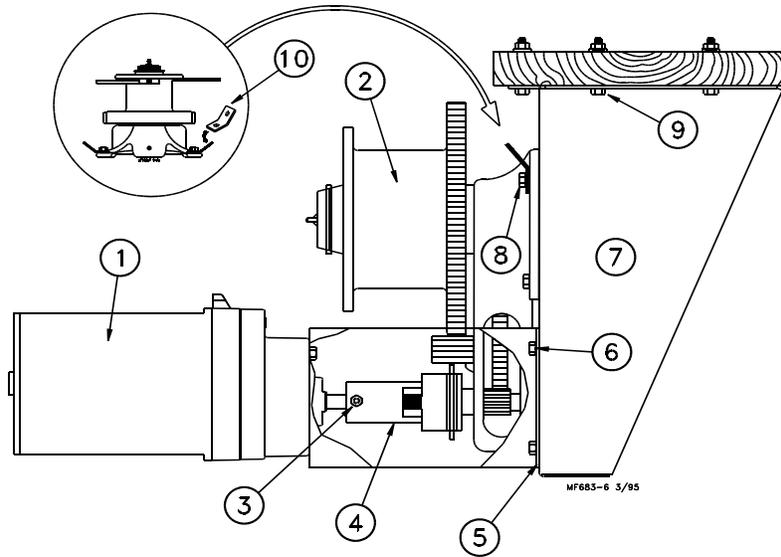

Item	Description	Item	Description
1	Power Unit	6	5/16-18 x 3/4" Bolt
2	Winch	7	Winch Bracket
3	1/4-20 Sock Hd Bolt and Locknut Supplied	8	3/8-16 x 1" Bolt
4	Heavy Duty Input Shaft	9	5/16-18 x 2-1/2" Bolt
5	Install Spacer between Power Unit Bracket Flanges and Winch Bracket.	10	Cable Hook

Figure 20. Power Winch Installation (Side View).

6. Place the Power Unit Bracket over the top of the Power Winch and bolt it to the Winch Bracket with 5/16-18x3/4" Bolts. Be sure to install the Spacer between the Power Unit Bracket flanges and Winch Bracket.
7. Slide the Input Shaft into position in the winch.
8. Replace the plastic shipping plug in the gearhead with the vented pipe plug provided.
9. Extend the 3/16" (5 mm) cable the full length of the feeder line. Attach the cable temporarily to the ceiling with nails, staples, or some type of fasteners.
10. Wrap the cable through the Winch Drum Relief located near the bottom of the drum. Tighten the set screw to anchor the cable to the drum, **see figure 21.**

Item	Description
1	Winch Drum Relief with set screw.
2	3/16" Winch Cable
3	Drum Rotation

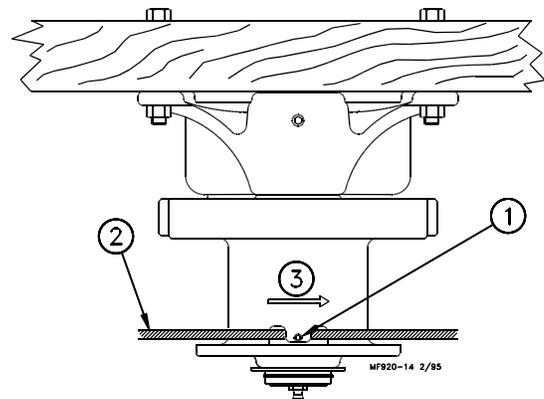

Figure 21. Cable Installation (Side View).

11. Turn the winch drum one full revolution. Guide the cable against the flange at the bottom of the winch drum. The cable must not wrap over itself on the drum, but should be wrapped as close as possible to each previous wrap. See **Figure 24**.

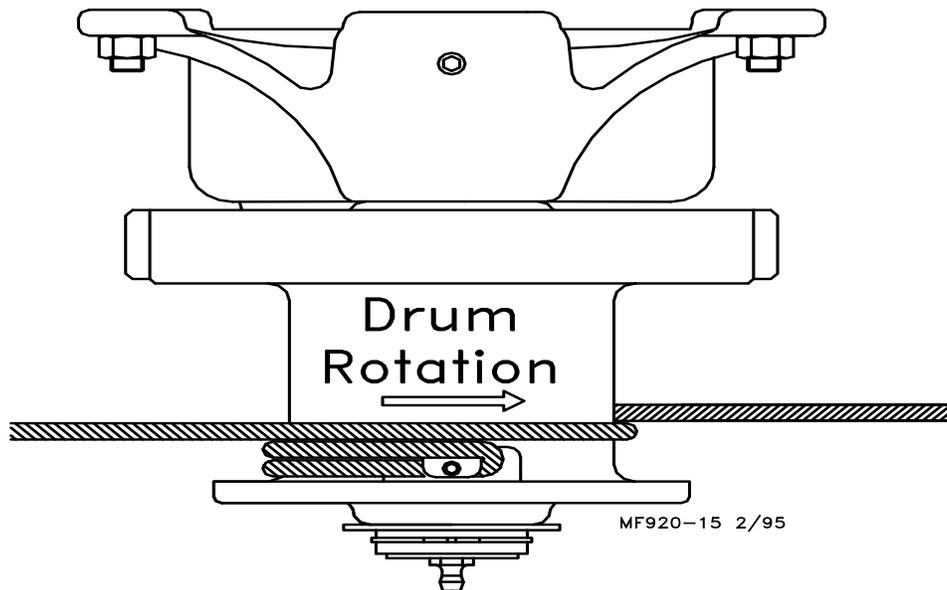

Figure 24. Cable Installation (End View)

## Drop Installation

1. Attach a 3004 Pulley to each hook.
2. Thread the end of the 3/32" or 1/8" cable through the pulley toward the winch. Clamp this end to the 3/16" winch cable about 6" (150 mm) from the last pulley, using a 3/16" cable clamp. See **Figure 8 on page 12**.
3. Allow enough cable length for installation of the Cable Lock.  
Sufficient cable is included to provide "throwbacks" on drops located beneath and near the winch. See **Figure 9 on page 12** for "throwback" arrangement.
4. **Begin installing suspension drops at the winch and proceed to the ends of the feeder line.**  
Keep the main cable tight between drops. It may be necessary to hang a weight on the end of the cable to maintain tension on the line.

## Winch Control

The Winch Control is designed to automatically lower feeder or water lines at a preset times on the time clock or manually. The Winch Control is not designed to automatically raise feeder or waterer lines.

### Installation

Mount the Winch Control in a convenient location within view of the lines to be lowered.

Install the Tower Switch Assembly as specified in the instructions (MV978) provided with the Tower Switch. The Tower Switch Assembly for the Winch Control uses three individual switches, instead of two.

The upper two switches determine the upper and lower limits of travel. The bottom switch serves as a safety switch.

Set the bottom switches (safety switch) of the Tower Switch approximately 1" (25 mm) below the center switch.

Wire the Winch Control as shown in the wiring diagram in this instruction.

NOTE: The Winch Control requires (5) conductors plus ground between the Winch Control and the Motor.

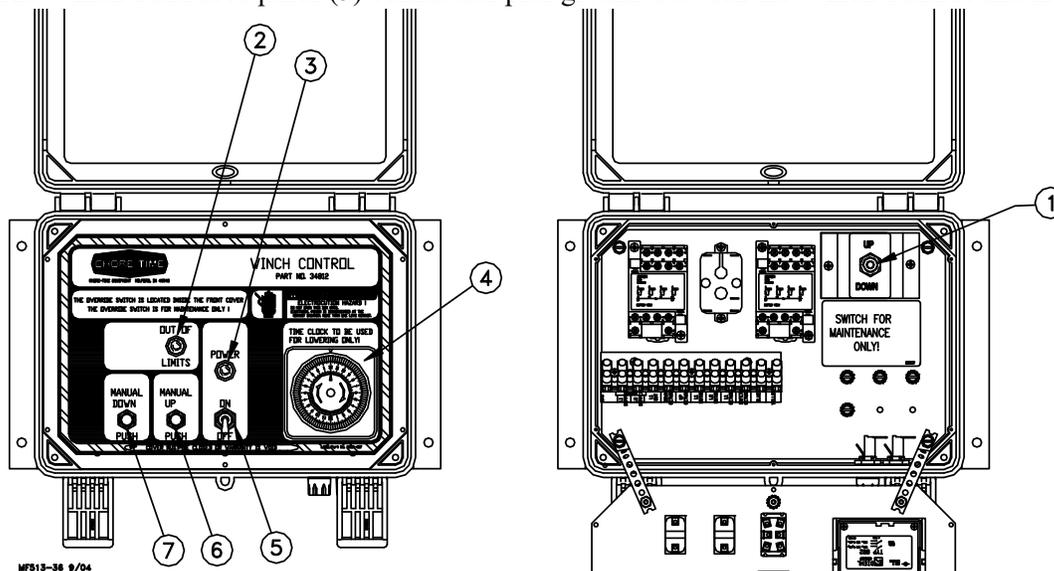

Figure 22. Winch Control

### Operation

Set the Time Clock (4) to the appropriate time of day by gently turning the time clock dial.

If the Winch Control is to automatically lower the line, pull one tab at the desired time. If the Winch Control is not to be used automatically, do not pull any tabs.

Flip the POWER switch (5) to the ON position. The power light (3) should be lit.

To raise or lower the line, press and hold the appropriate MANUAL UP (6) or MANUAL DOWN (7) button.

If the safety limit switch is activated, the OUT OF LIMITS pilot light will be lit. The Winch Control will not operate after the safety switch has been actuated, until the OVERRIDE switch has been used to bring the line back to within the limits.

**CAUTION:** The OVERRIDE switch directly drives the line(s) up or down regardless of the Tower Switch settings. USE THE OVERRIDE SWITCH CAUTIOUSLY TO PREVENT EQUIPMENT DAMAGE.

Item	Description
1	Override switch: Used to directly drive the line(s) up or down.
2	Out of Limits Light: Indicates safety switches have been activated.
3	Power Light
4	Time Clock: Indicates time of day and may be set to automatically lower line(s) at a preset time.
5	Power switch
6	Manual Up switch: Used to raise the line(s).
7	Manual Down switch: Used to manually lower the line(s).

# Hopper Assembly Procedure

Loosely, assemble the 200# Hopper Side Panels, as shown in **Figure 23**, using 1/4-20 bolts and 1/4-20 hex nuts (supplied in Hardware Package). The Hopper should be assembled so that the "CHORE-TIME" decals are on opposite sides of the hopper.

Secure the Boot Hangers to the bottom of the hopper, using 1/4-20 hardware.

Install the Hanger Bracket Assembly *perpendicular* to the feeder line, using 1/4-20 hardware supplied. The Hopper Panel with Switch Hole should be directly over the feeder line.

Secure Adjustment Brackets to Hanger, using 5/16-18 bolt and lock nut, supplied.

With the Hopper assembled, less the cover, tighten the hardware.

A Cable Assembly (including 20' or 6 meters of cable, a Sleeve Clamp, and a 5/32" Thimble) is supplied to suspend the hopper. **Figure 24** shows the suspension components assembled. The pin should be located in the center hole of the Hanger.

Install the Hopper Switch, as shown in **Figure 23**.

**Figure 25** shows the assembled hopper with suspension components installed.

Suspend the hopper, as shown in **Figure 3 page 10** by routing the cable around the Full Line Suspension Pulley and fastened to the main cable, using (2) cable clamps.

To install the boot on the hopper, slide the boot onto the hangers built into the bottom of the hopper.

Item	Description
1	Hopper Cover (stationary half)
2	Hopper Cover (removable)
3	Hair Pin
4	Adjustment Bracket
5	Clevis Pin
6	Hanger Bracket
7	Side Panel (w/Hole)
8	Lower Hopper Level Switch
9	Deflector
10	Diaphragm
11	Boot Hanger
12	Side Panel (w/o Hole)
13	Tube Support Kit

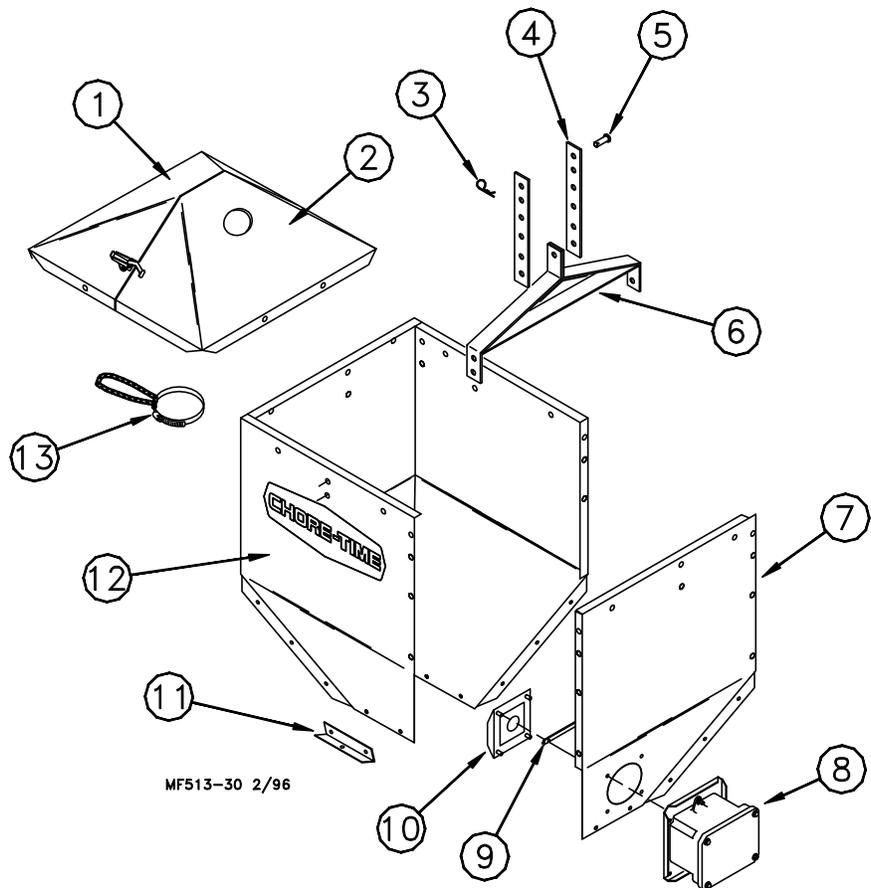
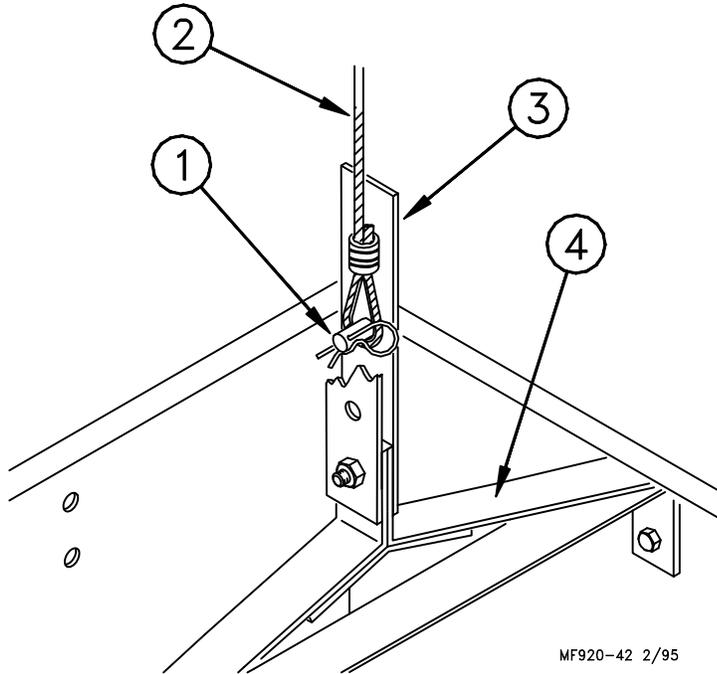

Figure 23. 200# Hopper Assembly Procedure



Item	Description
1	Clevis Pin and Hair Pin
2	Cable Assembly
3	Adjustment Bracket
4	Hanger Bracket

MF920-42 2/95

Figure 24. 200# Hopper Suspension components.

Use cotter pins, supplied, to secure the boot to the hopper.

The Hopper Cover, shown in **Figure 23**, is optional and must be ordered separately, if desired.

Secure the half of the cover with the tube opening on the top of the hopper. The other half of the cover will latch in place.

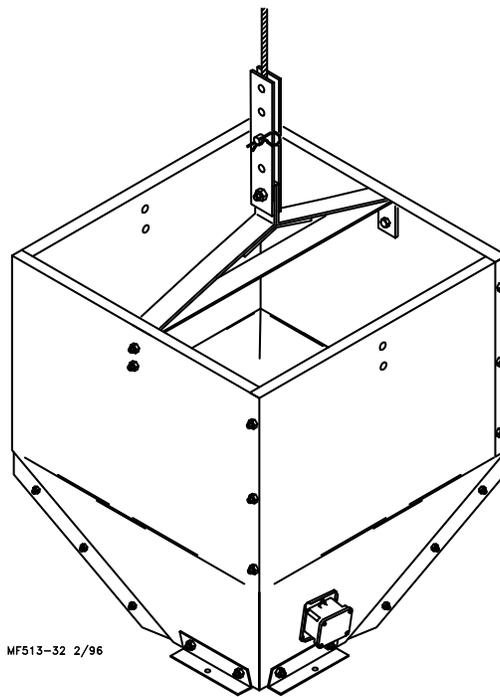

MF513-32 2/96

Figure 25. Assembled 200# Hopper w/o Cover.

# Feeder Assembly Procedure

## Assembly Box Construction

This information and assembly only applies to Model C2 Plus installations.

Chore-Time recommends building an assembly box to aid in assembling the Model C2 Plus feeders.

To build the assembly box for the C2 Plus Feeder, use a 16" (406 mm) square piece of plywood and four 14-1/2" (368 mm) long pieces of 2 x 10 (20 x 250 mm).

1. Cut a 3/4" (20 mm) piece of plywood 16" (400 mm) square, see **figure 26**.  
Cut a 4" (100 mm) piece out of the middle of one side, see **figure 26**.
2. Center the grill on the 16" (400 mm) square piece of plywood. Use a pencil and draw around the outside edge of the grill as shown in **Figure 26**.  
Mark a "V" at each strut location.

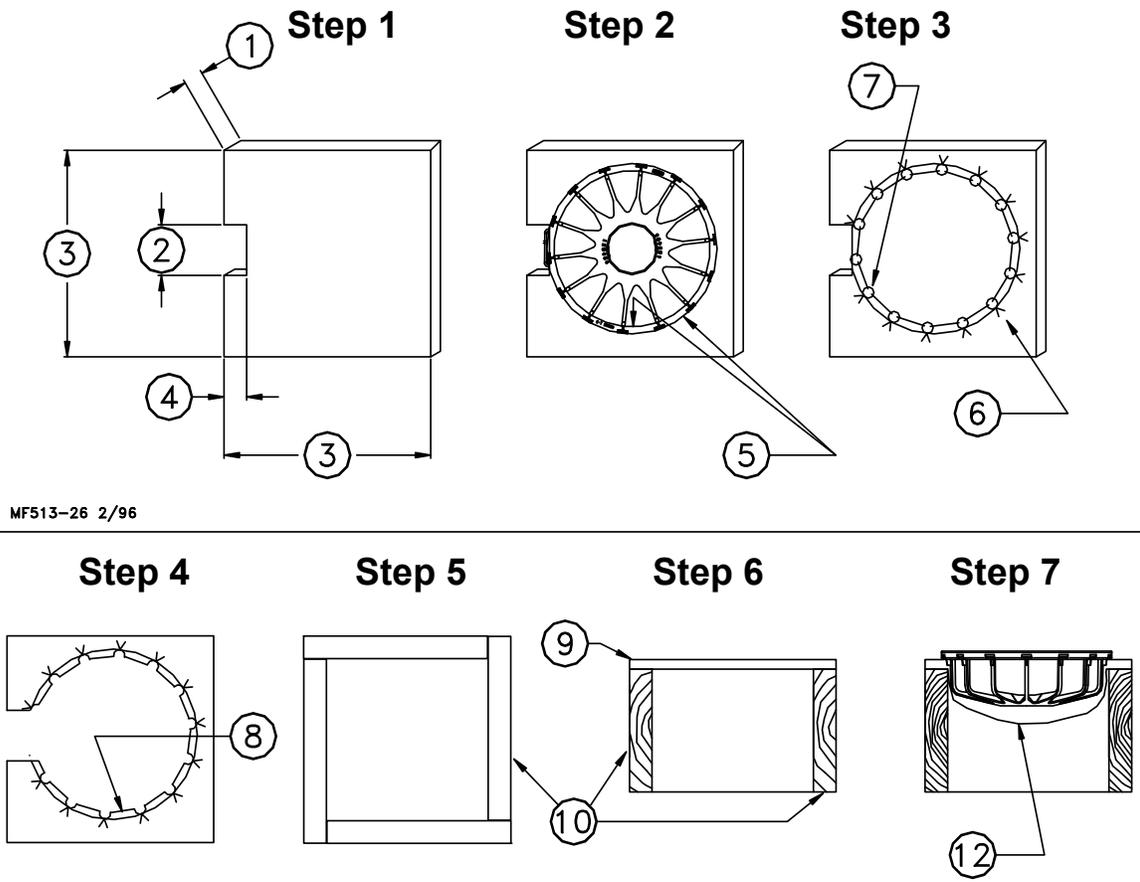

MF513-26 2/96

Item	Description	Item	Description
1	3/4" (19 mm)	7	Use a 7/8" Spade bit to drill a hole at each strut location.
2	4" (100 mm)	8	Cut on inside circle
3	16" (406 mm)	9	3/4" (19 mm) Plywood with cut-out
4	3" (75 mm)	10	2" x 10" x 13" (50 x 250 x 33 mm)
5	Center a grill on the board and draw around the outside & between the struts on the inside.	11	--
6	Mark a "V" at each strut location	12	Board is shown cut away to clearly show the grill set in assembly box.

Figure 26. Box Construction

- Remove the grill.

Use a 7/8" (22 mm) spade bit to drill a hole at each strut location, as shown in **Figure 26**.

- Use a sabre saw to cut along the *inside* circle, between the 7/8" holes, **see figure 26**.
- Use (4) 14-1/2" (370 mm) 2 x 10's (50 x 250 mm) to construct the box sides, **see figure 26**.

It is important to use at least 10" (250 mm) sides for the box. Smaller lumber will not allow sufficient depth for the grill to be placed in the box face down.

- Nail the 3/4" plywood fixture to the box, **see figure 26**.

**Figure 26** shows how the grill should fit down in assembly box. NOTE: Board is cut away for clarity only.

## Pan Assembly Procedure

- Place a Grill in the pan assembly box fixture. Make sure the hinge lip on the grill is located in the cut out section of the box.
- Two-Piece Model C2 Plus Feeders: Install the Cone Adjustment and Support Cone in the grill, as shown in **Figure 27**.

One-Piece Model C2 Plus Feeders: Install the One-Piece Support Cone in the grill, as shown in **Figure 27**.

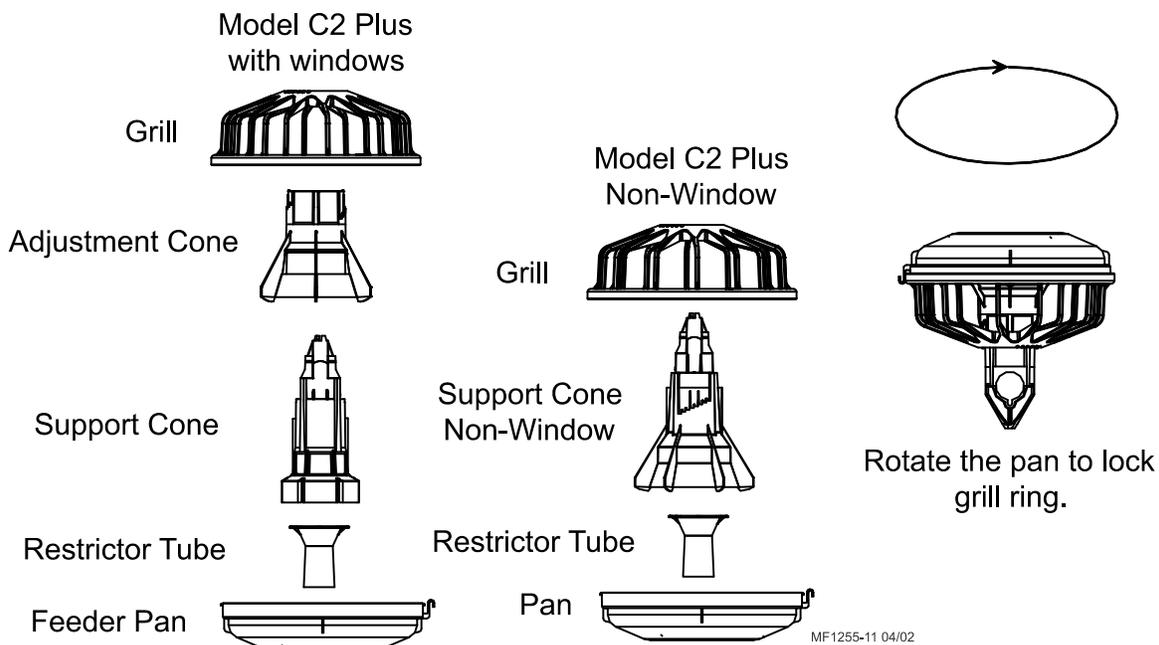

**Figure 27. Model C2 Plus Feeder Assembly**

- Interlock the hinge hook on the pan with the hinge lip on the grill. The pan should be face up, as shown in **Figure 28**.  
Flip the pan into the groove of the grill.
- With the feeder still in the fixture, rotate the pan clockwise in the grill until pan locks engage.  
The tabs (on the bottom of the pan) may be used to grip the pan when rotating.
- Remove the pan assembly from the fixture.
- Build all the required Feeder Assemblies for the house.

The Feeder Assemblies will be installed on the auger tubes in the Feeder Line Installation section.

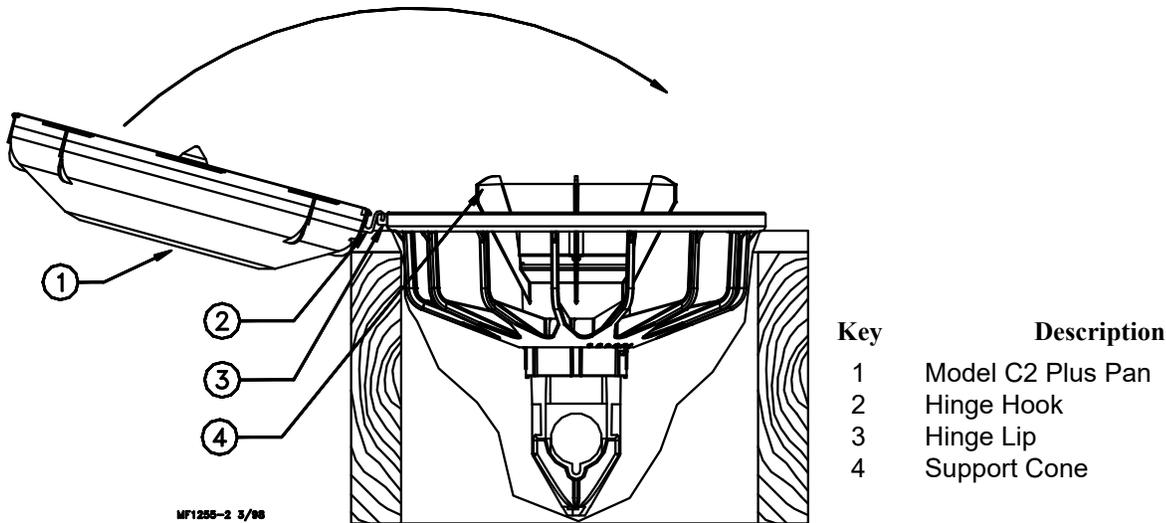

Figure 28. C2 Pan Assembly

## Feeder Line Assembly & Suspension

### Feeder Pan and Tube Assembly Process

- Slide one Feeder Pan Assembly per hole onto the Auger Tubes.

**IMPORTANT:** Install all the feeders on the tubes in the same orientation.

When sliding the feeders on the tubes, make sure the grill openings or hinges are on the same side of the tube.

- Rotate the auger tubes so that the seam is down, this holds the Pan Assemblies in place on the tubes, see figure 29.

### Assemble and Suspend the Feeder Line

- With the Hem of the Feeder Tube up slide the Feeder Pan Assembly on the Feeder Tube. Position one (1) Feeder Pan Assembly over each hole on the Feeder Tube.

- Rotate the Feeder Tube after the Feeder Pan Assemblies are in place. This will lock the Feeder Pan Assemblies in place

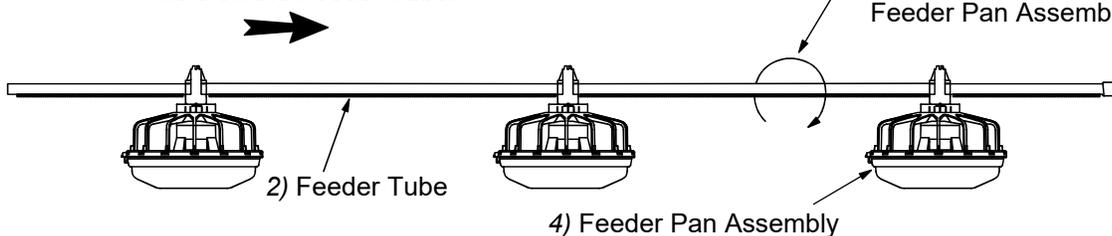
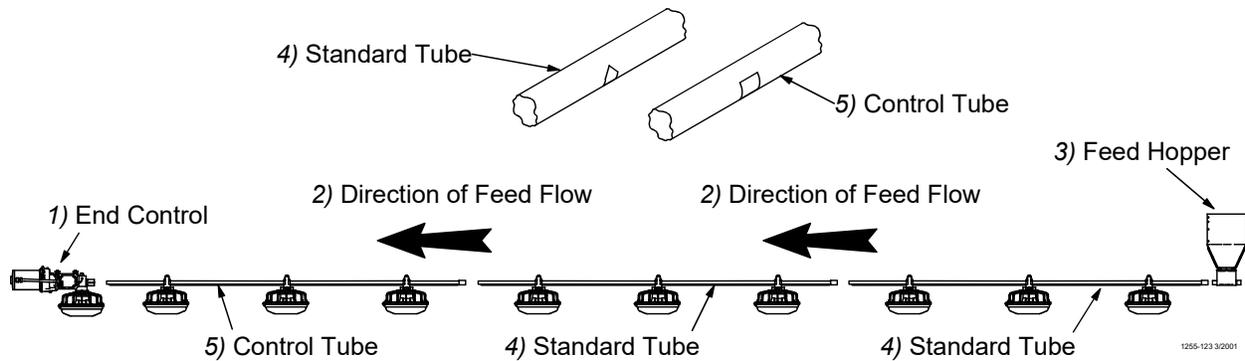

Figure 29. Assemble Feeders on Tubes

- The auger tubes and feeders may be laid out end to end in approximately the final location of the line. **The expanded end of each tube should be toward the Hopper end of the line, see figure 30.**
- Connect the individual feeder tubes together by inserting the straight end of one tube as far as possible into the belled end of the next tube.

Use suspension drop lines and Hangers to support the tubes as they are being installed. Make sure the tubes are level.



**Figure 30. Assemble Feeders on Tubes**

- Use a marker to number the Auger Tubes, beginning at the Hopper. The first Auger Tube at the hopper end of the feeder line would be 1, the second Auger Tube would be 2, etc. Mark each Auger Tube between the hopper and the Control Unit.
- Place a Tube Clamp Assembly or Clamp/Anti-Roost Bracket at each joint. **Figure 31** shows the standard Clamp and Clamp/Anti-Roost Bracket.

Systems using 9' Auger Tubes require a Clamp/Anti-Roost Bracket at every **fifth** joint.

Systems using 12' tubes require a Clamp/Anti-Roost Bracket at every **fourth** joint. All other joints in the system use the standard Tube Clamp Assembly.

Continue down the feeder line until each tube joint has a standard Tube Clamp or Clamp/Anti-Roost Bracket. Do not tighten at this time.

- The Adjustable Hanger is used to hang the feeder line. It is also used to index the feeder line.

Make sure the Adjustable Hanger is facing the proper direction, as specified in **Figure 32**. Refer to the appropriate Indexing Chart on page 27 or page 28 of this manual (depending on whether your Auger Tubes are 9' or 12' long) to program the Auger Tubes. The hanger settings are different for 9' and 12' Auger Tube. However, the settings will work for both mash or crumbles feed.

Find the heading for the number of tubes in your feeder line in the horizontal line at the top of the Indexing Chart. The correct hanger adjustments for each feeder tube are shown in the column under the heading.

Setting Example: If the appropriate setting for the #7 Auger Tube is D5, the "S" Hook should be installed in the #5 hole in the Hanger. The Auger Tube Seam should be in the "D" position, **see figure 33**.

Program each Auger Tube in the feeder line according to the Indexing Chart. Some Auger Tubes may have (2) Hangers, since suspension drop lines are 8' (2.4 m) apart. Both Hangers should be indexed to the same setting.

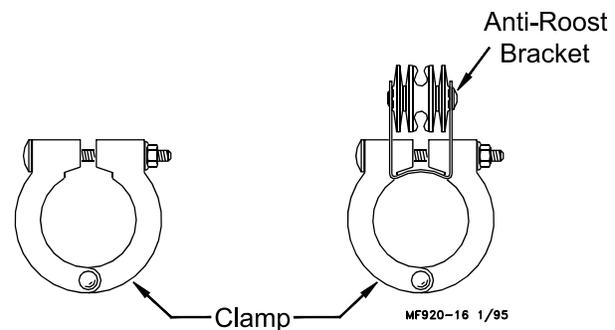

**Figure 31. Tube Clamps**

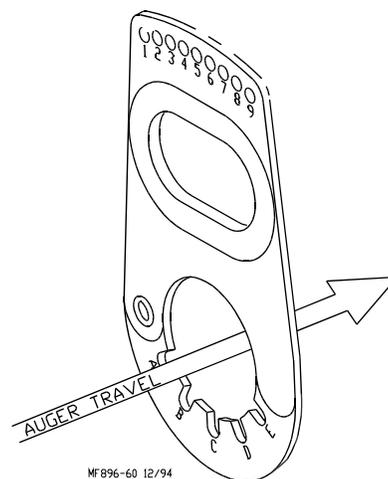

**Figure 32. Adjustable Hanger Orientation Diagram**

6. Install Adjustment Leveler within 6" (152 mm) of feeder line. **Figure 34** shows the proper cable routing around the Adjustment Leveler.
7. Raise the feeder line to a convenient working height.
8. With all the Adjustable Hangers in their appropriate settings, the Auger Tubes are ready to be fine tuned.

Begin at the hopper end of the house. Standing down the feeder line looking toward the hopper, the Indexing Gauge should be positioned between the second and third hole in the first Auger Tube with the notch over the tube seam. The Indexing Gauge must be on the right-hand side of the feeder line, **see figure 35**.

Set the clear pointer on the gauge to the proper setting according to the Indexing Chart.

Rotate the Auger Tube until the bubble in the leveler comes to the center. Tighten the clamp on the bell toward the hopper.

**Note: If the tube must be rotated so much that the Adjustable Hangers are tilted too far to one side or the other, check the following;**

- a. Make sure the Adjustable Hanger is set according to the Indexing Chart.
- b. Make sure the Indexing Gauge is set correctly according to the tube number and Indexing Chart.
- c. Make sure Indexing Gauge is placed on the tube correctly.
- d. Make sure that you are referring to the appropriate Indexing Chart for the length of Auger Tubes being indexed.

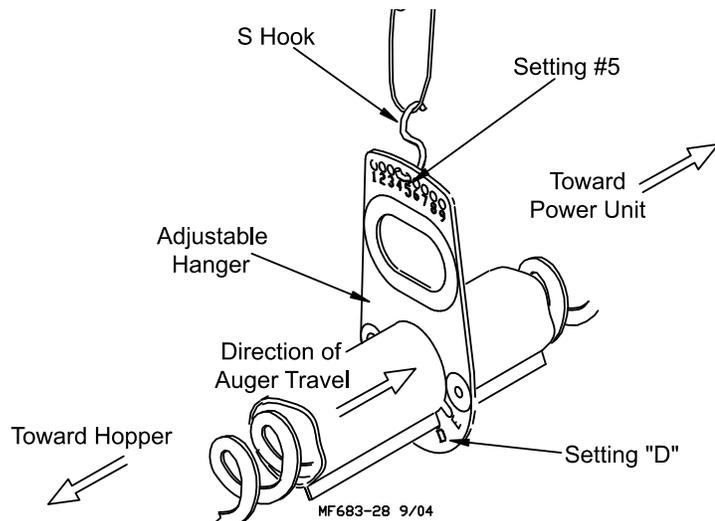

**Figure 33. Indexing the Feeder Line**

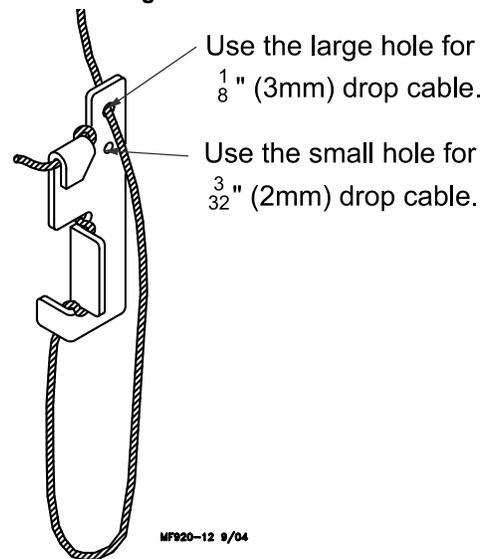

**Figure 34. Adjustment Leveler Installation**

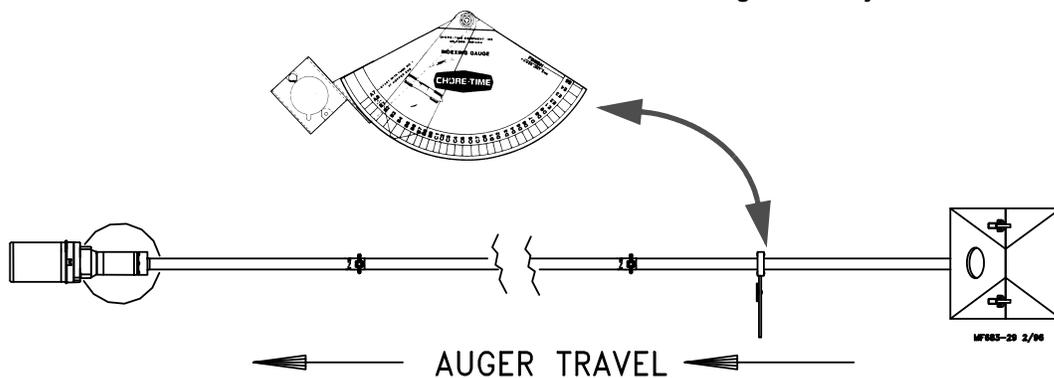
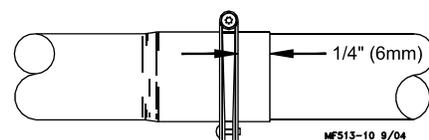

**Figure 35. Indexing the Feeder Line**

9. Continue to set each Auger Tube in the feeder line. After each tube is set, tighten the clamp on the bell end toward the hopper. The clamps should be positioned as shown in **Figure 36**. Do not crush the tubes by overtightening the clamps.

Be careful not to accidentally move the tube already set. This may require an extra person to hold the end of the tube just set, while you fine tune the next tube.

Be careful not to deform the tubes with wrenches or large adjustable pliers.

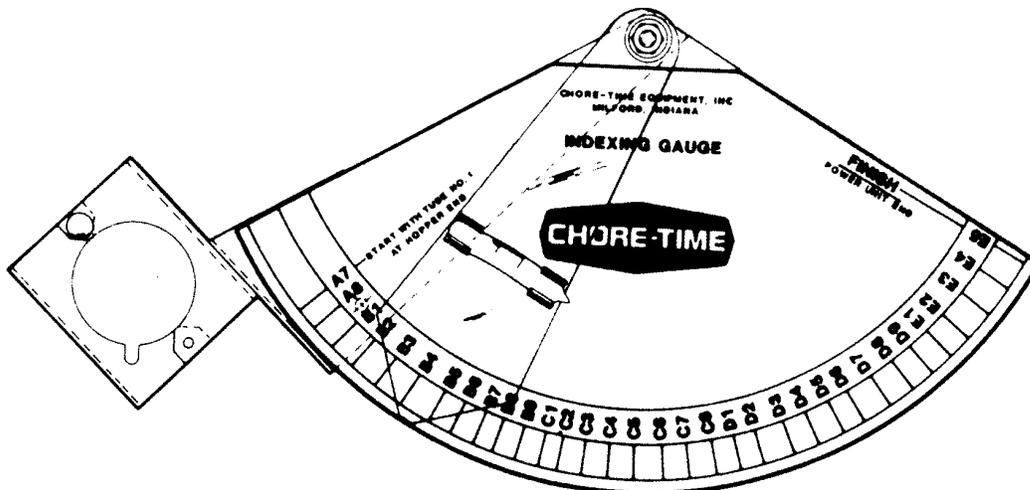

**Figure 36. Tube Clamp Location**

# Indexing Chart for Pan Breeder Feeders

For Systems using 9' (2.7 m) Auger Tube and 696 RPM Power Units

		Number of Tubes																
		31	30	29	28	27	26	25	24	23	22	21	20	19	18	17	16	
1	Tube Number	B5	B5	B6	B6	B6	B6	B6	B7	B7	B7	B8	B8	B8	B9	B9	B9	1
2		B6	B6	B7	B7	B7	B7	B7	B8	B8	B8	B9	B9	B9	C1	C1	C1	2
3		B7	B7	B8	B8	B8	B8	B8	B9	B9	B9	C1	C1	C1	C1	C1	C1	3
4		B8	B8	B9	B9	B9	B9	B9	C1	C1	C1	C1	C1	C1	C2	C2	C2	4
5		B9	B9	C1	C1	C1	C1	C1	C1	C1	C1	C2	C2	C2	C2	C2	C3	5
6		C1	C1	C1	C1	C1	C1	C1	C2	C2	C2	C2	C2	C2	C2	C3	C4	6
7		C1	C1	C2	C2	C2	C2	C2	C2	C2	C2	C3	C3	C3	C4	C5	C6	7
8		C2	C2	C2	C2	C2	C2	C2	C3	C3	C3	C4	C4	C4	C5	C6	C7	8
9		C2	C2	C3	C3	C3	C3	C3	C4	C4	C4	C5	C5	C5	C6	C7	C8	9
10		C3	C3	C3	C3	C4	C4	C4	C4	C4	C5	C6	C6	C6	C7	C8	D2	10
11		C3	C3	C4	C4	C4	C4	C5	C5	C5	C6	C7	C7	C7	C8	D2	D4	11
12		C4	C4	C4	C4	C5	C5	C5	C6	C6	C7	C7	C8	C8	D2	D4	D6	12
13		C4	C4	C5	C5	C5	C5	C6	C7	C7	C7	C8	C8	D2	D4	D6	D7	13
14		C5	C5	C5	C5	C6	C6	C7	C7	C7	C8	C8	D2	D4	D6	D7	D8	14
15		C5	C5	C6	C6	C7	C7	C7	C8	C8	C8	D2	D4	D6	D7	D8	E3	15
16		C6	C6	C6	C7	C7	C7	C8	C8	C7	D2	D4	D6	D7	D8	E3	E5	16
17		C6	C6	C7	C7	C8	C8	C8	D1	D2	D4	D6	D7	D8	E3	E5		17
18		C7	C7	C7	C8	C8	C8	D1	D2	D4	D6	D7	D8	E3	E5			18
19		C7	C7	C8	C8	D1	D1	D2	D4	D6	D7	D8	E3	E5				19
20		C8	C8	C8	D1	D2	D2	D4	D6	D7	D8	E3	E5					20
21		C8	C8	D1	D2	D3	D4	D6	D7	D8	E3	E5						21
22		D1	D1	D2	D3	D4	D6	D7	D8	E3	E5							22
23		D2	D2	D3	D4	D6	D8	D8	E3	E5								23
24		D3	D3	D4	D6	D8	D9	E3	E5									24
25		D4	D4	D6	D8	D9	E3	E5										25
26		D5	D6	D8	D9	E3	E5											26
27		D6	D8	D9	E3	E5												27
28		D8	D9	E3	E5													28
29		D9	E3	E5														29
30		E3	E5															30
31		E5																31



For Systems using 12' (3.6 m) Auger Tube and 696 RPM Power Units

Tube Number	Number of Tubes															
	31	30	29	28	27	26	25	24	23	22	21	20	19	18	17	16
1	B5	B5	B5	B5	B6	B6	B6	B6	B6	B7	B7	B7	B7	B8	B8	B8
2	B6	B6	B6	B6	B7	B7	B7	B7	B7	B8	B8	B8	B8	B9	B9	B9
3	B7	B7	B7	B7	B8	B8	B8	B8	B8	B9	B9	B9	B9	C1	C1	C1
4	B8	B8	B8	B8	B9	B9	B9	B9	B9	C1	C1	C1	C1	C2	C2	C2
5	B9	B9	B9	B9	C1	C1	C1	C1	C1	C1	C2	C2	C2	C2	C3	C3
6	C1	C1	C1	C1	C1	C1	C1	C2	C2	C2	C2	C2	C2	C3	C4	C4
7	C1	C1	C2	C2	C2	C2	C2	C2	C2	C2	C3	C3	C3	C4	C5	C6
8	C2	C2	C2	C2	C2	C2	C2	C3	C3	C3	C4	C4	C4	C5	C6	C7
9	C2	C2	C3	C3	C3	C3	C3	C4	C4	C4	C5	C5	C5	C6	C7	C8
10	C3	C3	C3	C3	C4	C4	C4	C4	C4	C5	C6	C6	C6	C7	C8	D2
11	C3	C3	C4	C4	C4	C4	C5	C5	C5	C6	C7	C7	C7	C8	D2	D5
12	C4	C4	C4	C4	C5	C5	C5	C6	C6	C7	C7	C7	C8	C8	D2	D5
13	C4	C4	C5	C5	C5	C5	C6	C7	C7	C7	C8	C8	D2	D4	D6	D7
14	C5	C5	C5	C5	C6	C6	C7	C7	C7	C8	C8	D2	D4	D6	D7	D8
15	C5	C5	C6	C6	C7	C7	C7	C8	C8	C8	D2	D4	D6	D7	D8	E3
16	C6	C6	C6	C7	C7	C7	C8	C8	C7	D2	D4	D6	D7	D8	E3	E5
17	C6	C6	C7	C7	C8	C8	C8	D1	D2	D4	D6	D7	D8	E3	E5	
18	C7	C7	C7	C8	C8	C8	D1	D2	D4	D6	D7	D8	E3	E5		
19	C7	C7	C8	C8	D1	D1	D2	D4	D6	D7	D8	E3	E5			
20	C8	C8	C8	D1	D2	D2	D4	D6	D7	D8	E3	E5				
21	C8	C8	D1	D2	D3	D4	D6	D7	D8	E3	E5					
22	D1	D1	D2	D3	D4	D6	D7	D8	E3	E5						
23	D2	D2	D3	D4	D6	D8	D8	E3	E5							
24	D3	D3	D4	D6	D8	D9	E3	E5								
25	D4	D4	D6	D8	D9	E3	E5									
26	D5	D6	D8	D9	E3	E5										
27	D6	D8	D9	E3	E5											
28	D8	D9	E3	E5												
29	D9	E3	E5													
30	E3	E5														
31	E5															

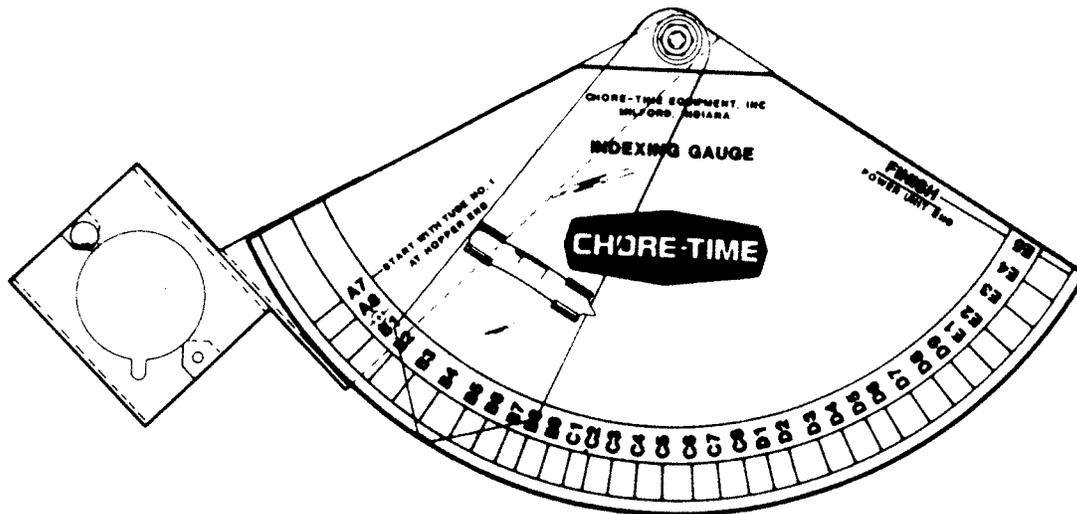

## Indexing the Male Feeder

1. Beginning at the hopper, use a marker to number the feeder tubes. Begin with tube #1 at the hopper, then #2, #3, and do on, continuing until each tube in the line is marked.
2. Loosen the tube clamps, or if a new house, leave the tube clamps loose, until the line has been indexed.
3. Use the Proper Indexing Chart for the tube that is being indexed. The indexing starts are based on the tube length.

Find the heading for the number of tubes in your system in the horizontal line at the top of the indexing chart. The correct hanger adjustments for each feeder tube are shown in the column under the heading.

4. After all Hanger Assemblies have been installed, use the Indexing Gauge to accurately set and adjust the feeder line.

Start at the hopper end of the house. Standing down the feed line looking back at the hopper, the Indexing Gauge should be placed with the notch over the crimped portion of the tube with the gauge on the right side of auger tube, The Index gauge should be placed between the second and third hole on tube #1, **see figure 37.**

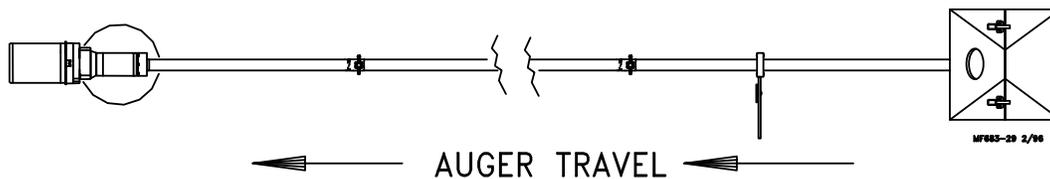

**Figure 37. Indexing the feeder line**

5. Set the clear pointer on the gauge to the proper setting according to the indexing chart. Rotate the tube until the bubble in the leveler comes to the center. Tighten the clamp on the bell toward the hopper.

**Note: If the tube must be rotated so much that the Hanger Assembly is tilted too far to one side or the other, check the following:**

- Make sure the Hanger Assembly is set according to the appropriate Indexing Chart.
- Make sure the Indexing Gauge is set correctly according to the Indexing Chart.
- Make sure the Indexing Gauge is placed on the tube correctly.
- Make sure that the settings for both the Indexing Gauge and the adjustable hangers are taken from the correct chart for length of auger tube being indexed.

6. Index each of the remaining tubes in the same manner. After each tube has been set, tighten the clamp on the bell end toward the hopper.

Position the clamps on the tube joints, as shown in **Figure 36.**

**Note: Use two large adjustable pliers or pipe wrenches to grip the tube; being careful not to deform the tubes.**

Make sure the tubes already set do not move. (This will require a second person to hold the end of the tube that has just been set while you turn the next tube to be set.)

7. Close both ends of the "S" Hook between the cable and Hanger.

# Indexing Chart for Male Feeders

For Systems using 9' (2.7 m) Auger Tube and 348 RPM Power Units

		Number of Tubes																	
		31	30	29	28	27	26	25	24	23	22	21	20	19	18	17	16		
Tube Number	1	B4	B4	B4	B4	B4	B5	B5	B5	B5	B6	B6	B6	B7	B7	B7	B7	1	
	2	B5	B5	B5	B5	B5	B6	B6	B6	B6	B7	B7	B7	B8	B8	B8	B8	2	
	3	B6	B6	B6	B6	B6	B7	B7	B7	B7	B8	B8	B8	B9	B9	B9	B9	3	
	4	B7	B7	B7	B7	B7	B8	B8	B8	B8	B9	B9	B9	C1	C1	C1	C1	4	
	5	B8	B8	B8	B8	B8	B9	B9	B9	B9	C1	C1	C1	C2	C2	C2	C2	5	
	6	B8	B9	B9	B9	B9	C1	C1	C1	C1	C2	C2	C2	C3	C3	C3	C3	6	
	7	B9	B9	C1	C1	C1	C2	C2	C2	C2	C3	C3	C3	C4	C4	C4	C5	C6	7
	8	B9	C1	C1	C1	C2	C2	C3	C3	C3	C4	C4	C4	C4	C4	C5	C6	C7	8
	9	C1	C1	C2	C2	C2	C3	C3	C3	C4	C4	C4	C4	C5	C6	C7	C8	9	
	10	C1	C2	C2	C2	C3	C3	C4	C4	C4	C5	C5	C5	C6	C7	C8	D1	10	
	11	C2	C2	C3	C3	C3	C4	C4	C4	C5	C5	C5	C6	C7	C8	D1	D2	11	
	12	C2	C3	C3	C3	C4	C4	C5	C5	C5	C6	C6	C7	C8	D1	D2	D3	12	
	13	C3	C3	C4	C4	C4	C5	C5	C5	C6	C6	C7	C8	D1	D2	D3	D5	13	
	14	C3	C4	C4	C4	C5	C5	C6	C6	C6	C7	C8	D1	D2	D3	D5	D7	14	
	15	C4	C4	C5	C5	C5	C6	C6	C6	C7	C8	D1	D2	D3	D5	D7	E2	15	
	16	C4	C5	C5	C6	C6	C6	C7	C7	C7	D1	D2	D3	D5	D7	E2	E3	16	
	17	C5	C5	C6	C6	C6	C7	C7	C8	C8	D2	D3	D5	D7	E2	E3		17	
	18	C5	C6	C6	C7	C7	C7	C8	D1	D1	D3	D5	D7	E2	E3			18	
	19	C6	C6	C7	C7	C7	C8	D1	D2	D2	D5	D7	E2	E3				19	
	20	C6	C7	C7	C8	C8	D1	D2	D3	D5	D7	E2	E3					20	
	21	C7	C7	C8	C8	D1	D2	D3	D5	D7	E2	E3						21	
	22	C7	C8	C8	D1	D2	D3	D5	D7	E2	E3							22	
	23	C8	C8	D1	D2	D3	D5	D7	E2	E3								23	
	24	C8	D1	D2	D3	D5	D7	E2	E3									24	
	25	D1	D2	D3	D5	D7	E2	E3										25	
	26	D2	D3	D5	D7	E2	E3											26	
	27	D3	D5	D7	E2	E3												27	
	28	D5	D7	E2	E3													28	
	29	D7	E2	E3														29	
	30	E2	E3															30	
	31	E3																31	

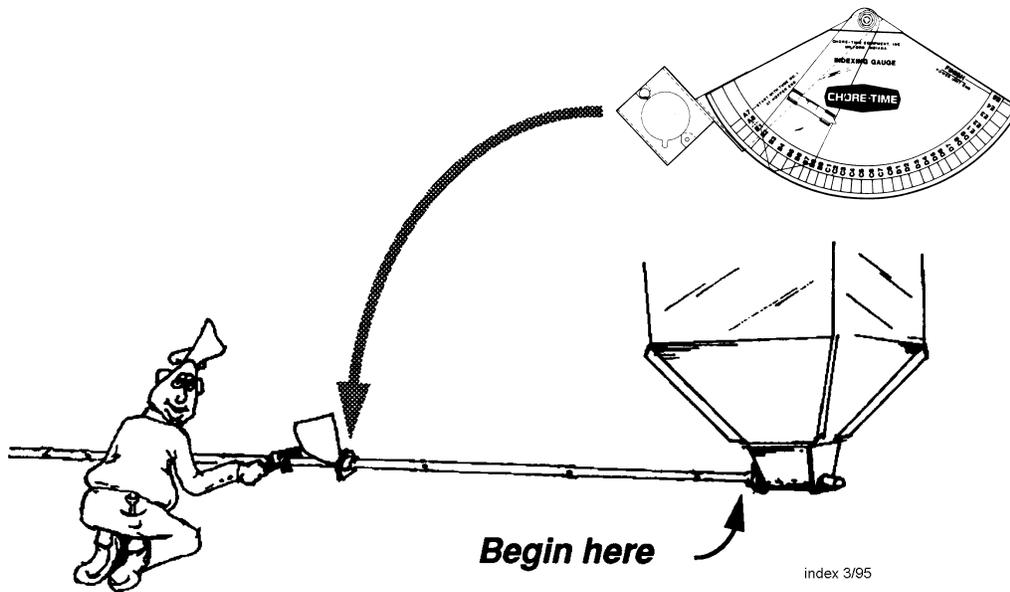

index 3/95

**For Systems using 12' (3.6m) Auger Tube and 696 RPM Power Units**

		Number of Tubes																	
		31	30	29	28	27	26	25	24	23	22	21	20	19	18	17	16		
Tube Number	1	B5	B5	B5	B6	B6	B6	B7	B7	B7	B8	B8	B8	B8	B9	B9	B9	1	
	2	B6	B6	B6	B7	B7	B7	B8	B8	B8	B9	B9	B9	B9	C1	C1	C1	2	
	3	B7	B7	B7	B8	B8	B8	B9	B9	B9	C1	C1	C1	C1	C2	C2	C2	3	
	4	B7	B8	B8	B9	B9	B9	C1	C1	C1	C2	C2	C2	C2	C3	C3	C3	4	
	5	B8	B8	B9	B9	C1	C1	C1	C1	C2	C2	C2	C3	C3	C4	C4	C4	5	
	6	B8	B9	B9	C1	C1	C1	C2	C2	C2	C3	C3	C3	C4	C4	C5	C5	6	
	7	B9	B9	C1	C1	C2	C2	C2	C2	C3	C3	C3	C4	C4	C5	C5	C6	7	
	8	B9	C1	C1	C2	C2	C2	C3	C3	C3	C4	C4	C4	C5	C5	C6	C7	8	
	9	C1	C1	C2	C2	C3	C3	C3	C3	C4	C4	C4	C5	C5	C6	C7	C8	9	
	10	C1	C2	C2	C3	C3	C3	C4	C4	C4	C5	C5	C5	C6	C7	C8	D1	10	
	11	C2	C2	C3	C3	C4	C4	C4	C4	C5	C5	C5	C6	C7	C8	D1	D2	11	
	12	C2	C3	C3	C4	C4	C4	C5	C5	C5	C6	C6	C7	C8	D1	D2	D3	12	
	13	C3	C3	C4	C4	C5	C5	C5	C5	C6	C6	C7	C8	D1	D2	D3	D5	13	
	14	C3	C4	C4	C5	C5	C5	C6	C6	C6	C7	C8	D1	D2	D3	D5	D7	14	
	15	C4	C4	C5	C5	C6	C6	C6	C6	C7	C8	D1	D2	D3	D5	D7	E2	15	
	16	C4	C5	C5	C6	C6	C6	C7	C7	C7	D1	D2	D3	D5	D7	E2	E3	16	
	17	C5	C5	C6	C6	C7	C7	C7	C8	C8	D2	D3	D5	D7	E2	E3		17	
	18	C5	C6	C6	C7	C7	C7	C8	D1	D1	D3	D5	D7	E2	E3			18	
	19	C6	C6	C7	C7	C8	C8	D1	D2	D2	D5	D7	E2	E3				19	
	20	C6	C7	C7	C8	C8	D1	D2	D3	D5	D7	E2	E3					20	
	21	C7	C7	C8	C8	D1	D2	D3	D5	D7	E2	E3						21	
	22	C7	C8	C8	D1	D2	D3	D5	D7	E2	E3							22	
	23	C8	C8	D1	D2	D3	D5	D7	E2	E3								23	
	24	C8	D1	D2	D3	D5	D7	E2	E3									24	
	25	D1	D2	D3	D5	D7	E2	E3										25	
	26	D2	D3	D5	D7	E2	E3											26	
	27	D3	D5	D7	E2	E3												27	
	28	D5	D7	E2	E3													28	
	29	D7	E2	E3														29	
	30	E2	E3															30	
	31	E3																31	

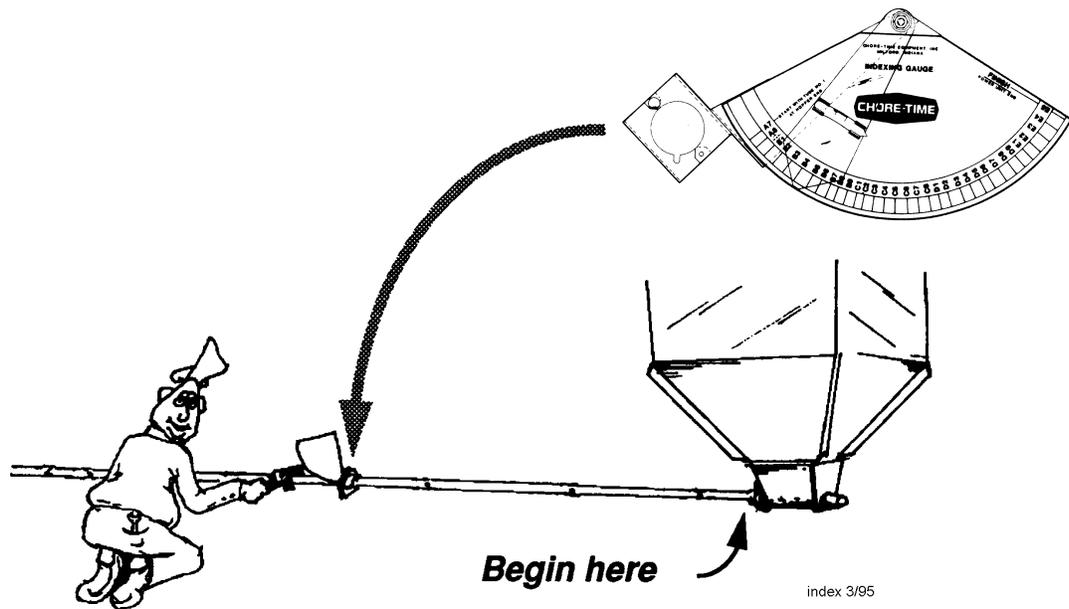

index 3/95

## Model C2 Plus Feeder Lock Installation

The Model C2 Plus Feeder Lock is designed for pullet operations to prevent the feeders from swinging on the auger tubes.

Note: The seam of auger tube and hardware for the Lock must be on opposite sides as shown. Otherwise an interference will occur.

Install the friction pad on the tube (remove oil from tube where the pad will be installed) where the anti swing clamp will be installed.

To install, gently spread the Lock to allow it to slide over the auger tube as shown in **Figure 38**.

Slide the Lock into position against the Feeder Support Cone.

Make sure the feeder is in the upright position before securing the Lock to the auger tube using the hardware supplied.

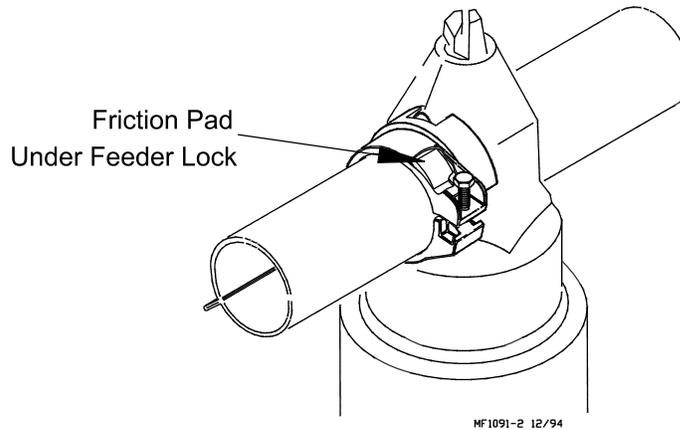

**Figure 38. Feeder Lock installation**

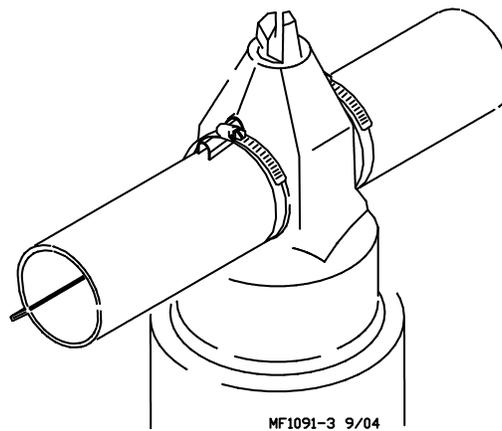
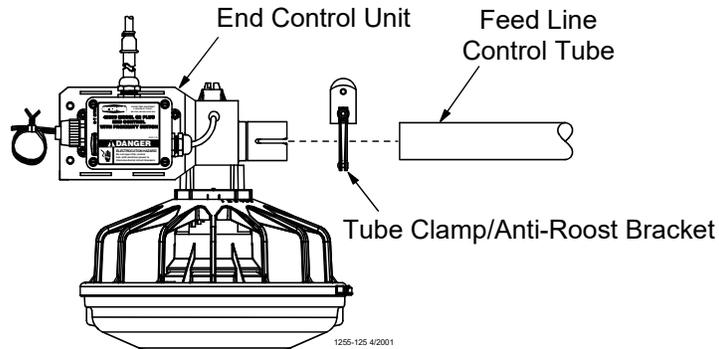

**Figure 39. Feeder Anti-Swing Clamp Installation**

## Installing the End Control, Boot Assembly, and Auger

The End Control Unit must be at least 10 feet [3 m] from the end of the building to allow birds access around the end of the feeder line.

1. Assemble the End Control Unit to the Feeder Line Control Tube using a clamp/anti-roost bracket. See **Figure 40**. **DO NOT INSTALL THE POWER UNIT AT THIS TIME.**



**Figure 40. Connecting End Control Unit to the Feed Line Tube**

2. Install the Feeder Boot by sliding the straight end of the Feeder Boot into the belled end of the Feeder Tube. Install a clamp/anti-roost bracket on the bell and tighten. The Feeder Boot must be level with the open top of the Feeder Boot flat. See **Figure 41**. **DO NOT INSTALL THE ANCHOR BEARING AND BEARING RETAINER AT THIS TIME.**

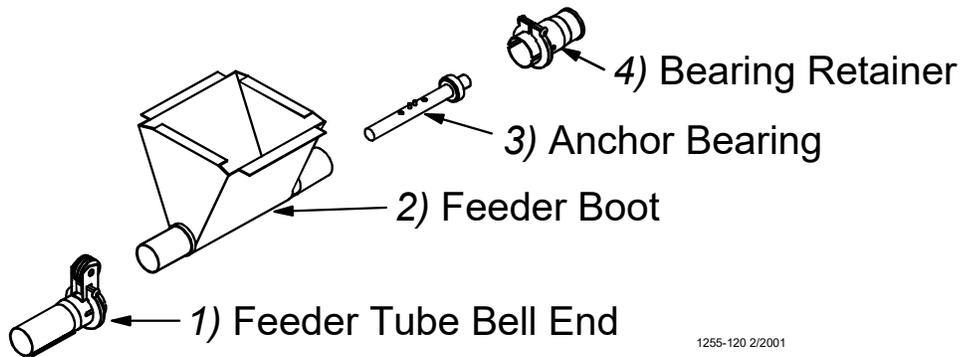

**Figure 41. Installing the Feeder Boot**

## Auger Installation

**Note:** Use extreme caution when working with the auger. The auger is under tension and may spring causing personal injury. Wear protective clothing, gloves, and safety glasses when working with the auger.

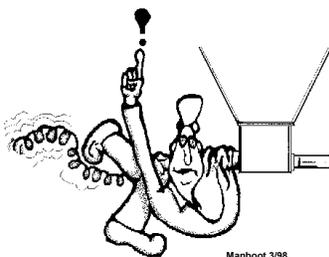

**BE CAREFUL WHEN  
WORKING WITH THE  
AUGER!**

To avoid kinking the auger, be careful not to drop the rolled auger when handling. Inspect the auger carefully as it is installed. Small kinks may be straightened. Large kinks must be removed and the auger brazed back together.

Cut the leading 18" [450 mm] and last 18" [450 mm] off each roll of auger. Also, cut out any other distorted auger sections and reconnect the auger as specified in the Auger Brazing section of this manual..



1. Use extreme caution when pushing the auger into the auger tubes. Keep your hand away from the end of the auger tube to avoid injury.

With the auger coiled about 6 feet [1.8 m] from the end of the boot, uncoil the auger from the outside and feed the auger through the boot into the tubes.

Push the auger into the tube in short strokes.

Uncoil and handle the auger carefully to avoid damaging or kinking the auger.

2. If more than one coil is required for each feeder line, the auger ends will have to be brazed together. Refer to the Brazing the Auger section in this manual.
3. Install the Anchor Bracket to the Power Unit/Gearhead, as shown in **Figure 42**, with the included 5/16-18 Bolts.

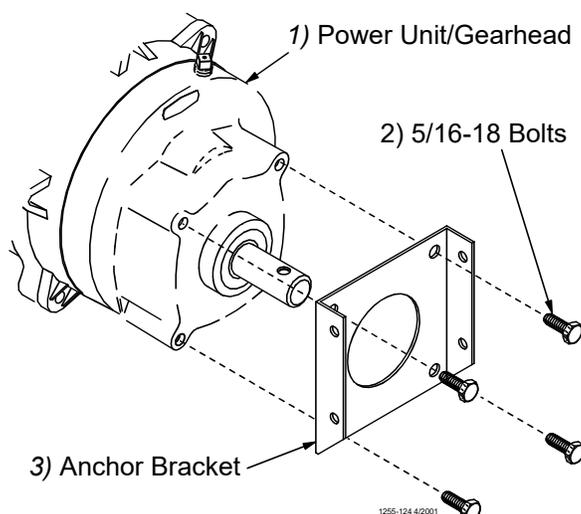

**Figure 42. Assemble the Anchor Bracket to the Power Unit/Gearhead**

4. Slide the Drive Tube and flat washer over the output shaft on the Power Unit, as shown in **Figure 43**.
5. Continue installing auger until the auger reaches the Control Unit end of the feeder line.
6. Turn the Drive Tube Weldment into the auger, then attach to the output shaft of the Power Unit, as shown in **Figure 43**. Use the Driver Block to secure the auger to the Output Shaft.

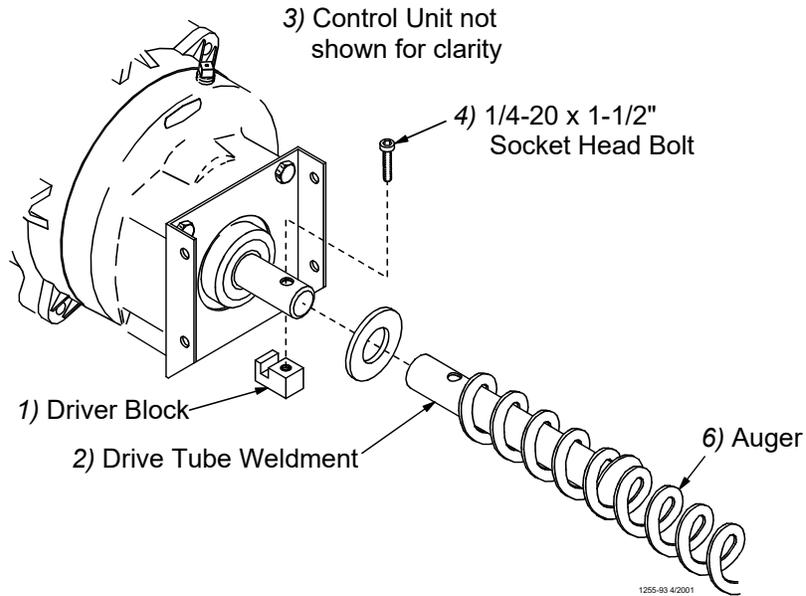

**Figure 43. Auger Driver Components**

7. Attach the Anchor Plate and Gearhead Assembly to the Control Unit Body using the included 1/4" Lock Washers and 1/4-20 x 1/2" Bolts, see **figure 44**.

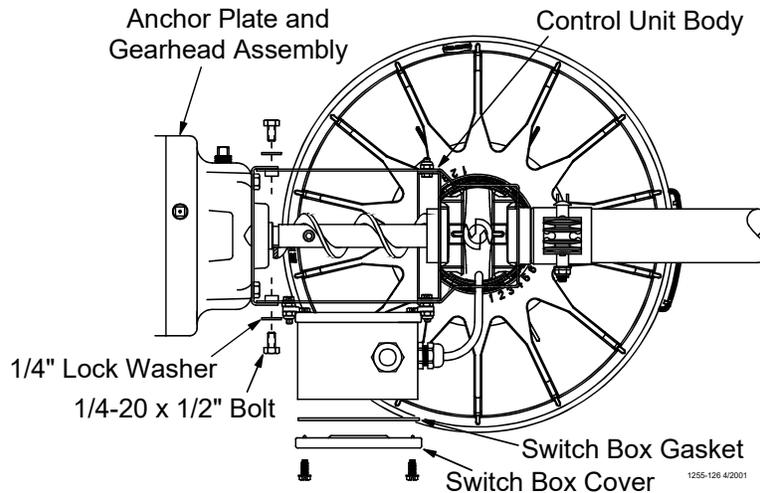

**Figure 44. Attaching the Anchor Plate and Gearhead Assembly to the Control Unit Body**

8. Install the Metal Water Tight Connector (item 1) in the Feed Line Motor (item 2). Cut the Flex Conduit (item 3) to length. Slide the wires from the end control through the Flex Conduit (item 3). Install the Flex Conduit (item 3) in the connectors. Connect the wires to the Feed Line Motor (item 2).

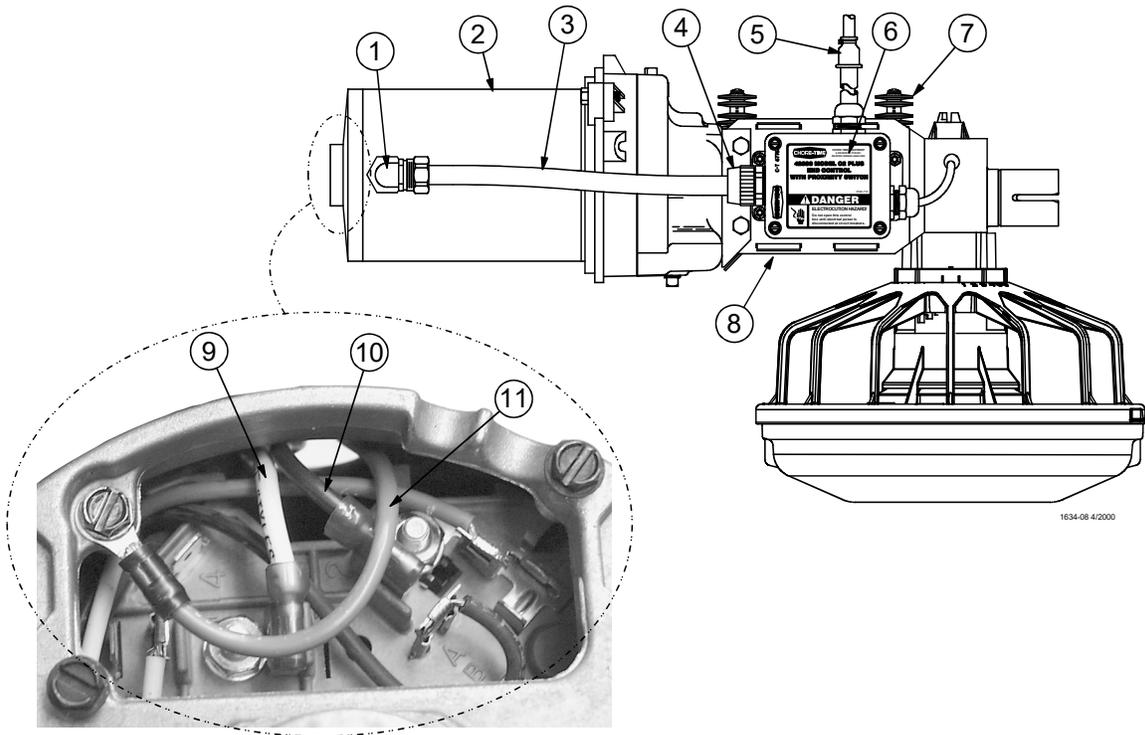

**Wiring the Motor**

9. Attach all covers and wire according to the wiring section of this manual.  
 10. Pull the auger at the boot end until it begins stretching. Then let it relax. In the *relaxed* position, mark the auger at the end of the boot. See **Figure 45**.

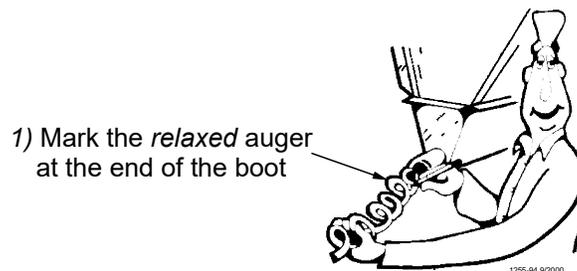

**Figure 45. Measure the Auger from the relaxed position**

11. Auger stretch:

The auger needs to be stretched 7" [180 mm] per 100' [30 m]. Example: A 300' [90 m] feeder line requires 21" [500 mm] of stretch.

Beginning at the *relaxed* position, measure the required amount of stretch. Mark the auger at that point.

Grip the auger 8" [200 mm] ahead of this mark with locking pliers. Allow the auger to pull back into the boot so that the pliers rest against the end of the boot. See **Figure 46**.

Use a hacksaw or bolt cutters to cut the auger at the stretched auger mark.

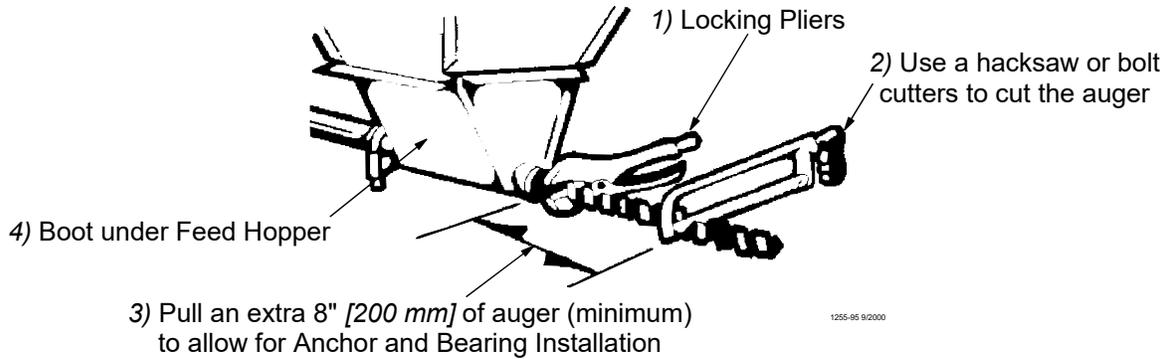

Figure 46. Cut the Auger with required stretch

12. Insert the Anchor Assembly into the auger until it touches the washer at the back of the anchor. Tighten the setscrews in the center of the anchor until they touch the auger, then tighten a maximum of 1/2 turn. See Figure 47.

**DO NOT OVERTIGHTEN THE SET SCREWS.**

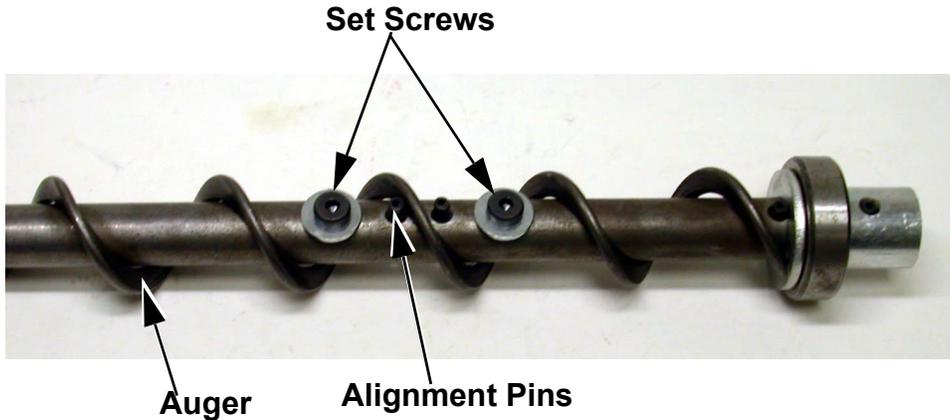

Figure 47. Auger and Anchor Bearing Connection

13. **Carefully** remove the locking pliers while holding onto the Anchor and Bearing Assembly and auger securely.  
**Slowly** ease the auger back into the tube. Use caution. If the auger is allowed to spring back, the bearing race may crack.  
 Install the Bearing Retainer and fasten with a tube clamp. Keep the Bearing Retainer flush with the end of the anchor for safety.
14. Place the cannonball in the boot.



**BE CAREFUL WHEN WORKING WITH THE AUGER!**

## Auger Brazing

The auger should be brazed if it is necessary to splice or lengthen it. A bronze, flux coated rod is recommended.

The ends of the auger should butt against each other, **DO NOT THREAD INSIDE EACH OTHER**. See **Figure 48. Figure 48.** The joint should be well filled with no sharp edges or rough corners to wear against the tube. To align the auger for brazing, lay it in angle or channel iron and clamp it firmly in place. Use low heat. Allow the joint to air cool; rapid cooling will cause the auger to become brittle.

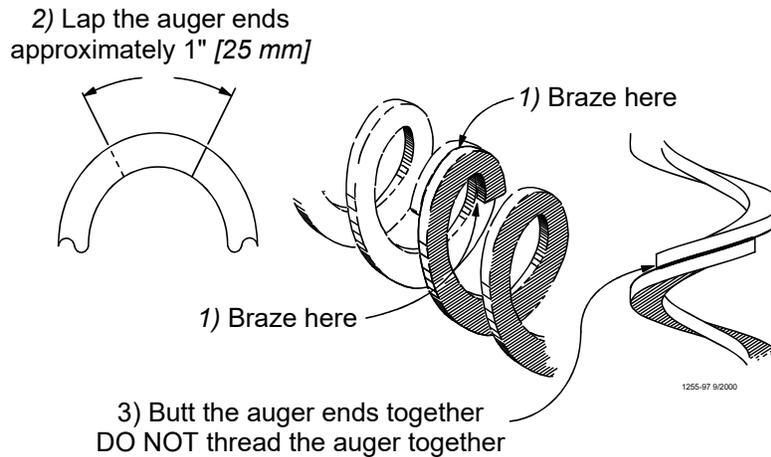

**Figure 48. Auger Brazing**

## Anti-Roost Installation

1. Unroll the bulk anti-roost cable. Note: If the cable is unrolled as shown in **Figure 49**, taking 5 loops of the coil with one hand, then changing hands to remove 5 loops as it is unrolled, it will lie flat during installation.

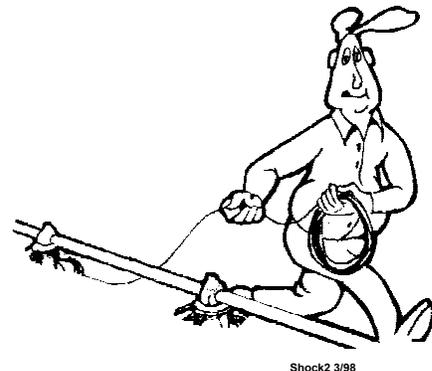

Shock2 3/98  
Figure 49. Unrolling the Cable

2. Start at the hopper end of the line and form a loop around the anti-roost bracket. For best results, make a double loop around the anti-roost insulator in the center groove of the insulator and fasten with a 1/16" cable clamp as shown in **Figure 50**.
3. Insert the cable in the insulator on the top of each Grill Support between the hopper and the next anti-roost bracket.

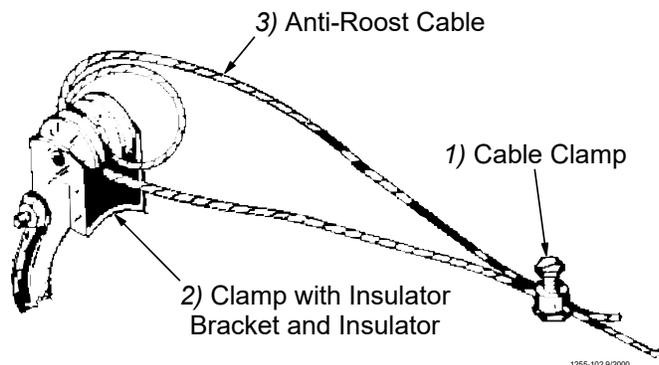

1255-102 9/2000  
Figure 50. Anti-Roost Cable at the Hopper

4. Attach a spring in the center groove at the second anti-roost bracket and cut the cable at this point. See **Figure 51**.
5. Thread the ends of the cable through the end of the spring. Pull the cable tight so that there is 3/4" to 1" [20 to 25 mm] of stretch in the spring. Clamp the cable to form a loop and cut off any excess. See **Figure 51**.
6. Attach the cable to the insulator. For best results, make a double loop around the anti-roost insulator in the center groove of the insulator and fasten with a 1/16" cable clamp as shown in **Figure 51**.

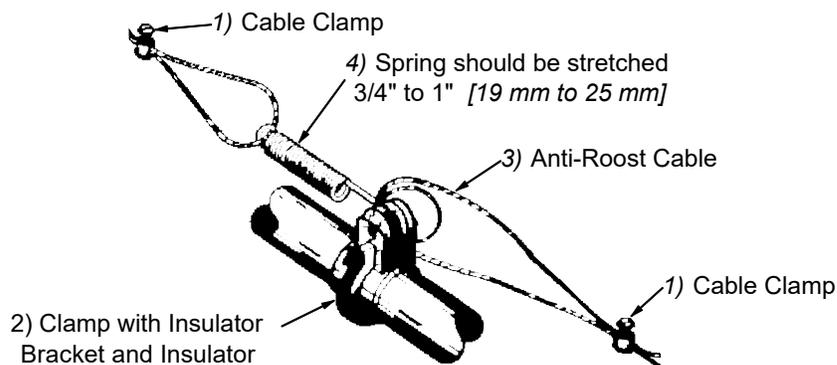

1255-103 9/2000  
Figure 51. Anti-

7. Run the cable to the next insulator, attach a spring in the center groove at the anti-roost bracket and cut the cable at this point. The cable should be positioned in the insulator built into the top of each grill support along the feeder line.
8. Repeat this installation until the anti-roost cable is installed along the entire feeder line.
9. At the control unit, after clamping the cable to the spring, cut the cable about 8" to 10" [200 to 250 mm] longer than necessary. Feed the end of the cable through the center of the spring, around the first insulator on the control unit, and clamp the cable using the cable clamp supplied with the control unit. See **Figure 52**.
10. Install the wire form on the control unit insulators. Be sure the guard snaps into the retainers molded into the insulators. See **Figure 52**.

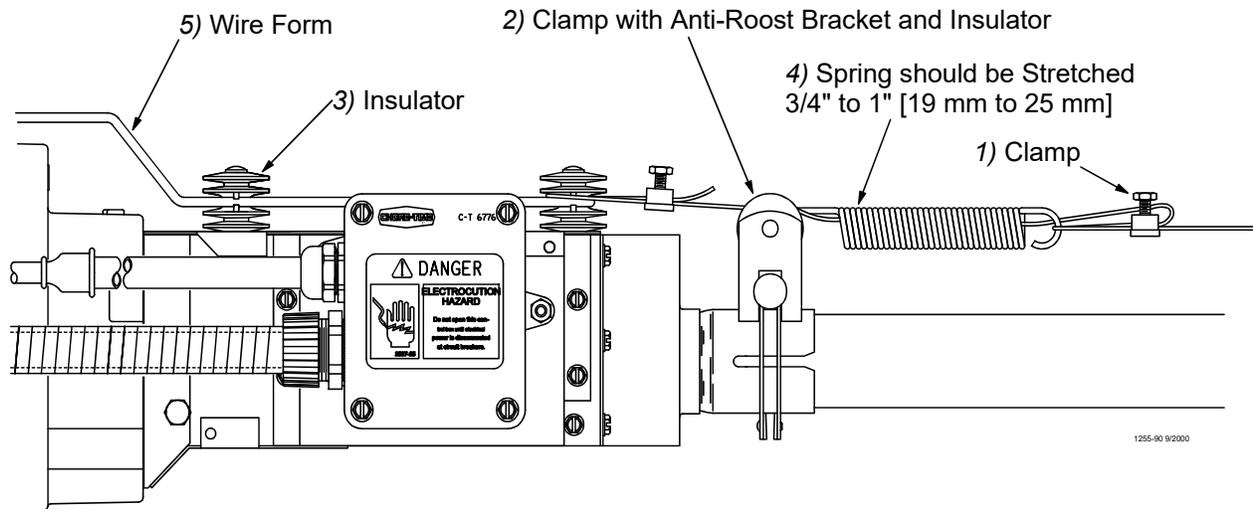

Figure 52. Anti-Roost Installation at the Control Unit

11. Install the Poultry Trainer or Line Charger, as shown in **Figure 53** or **54**.

The Poultry Trainer is used to power all Anti-Roost lines in a house. See **Figure 53**.

The Line Charger is used to power individual Anti-Roost lines in a house. See **Figure 54**.

Route the charger wire from the Poultry Trainer or Line Charger to the Anti-Roost system. Secure the Charger Wire to the Anti-Roost cable, using a cable clamp.

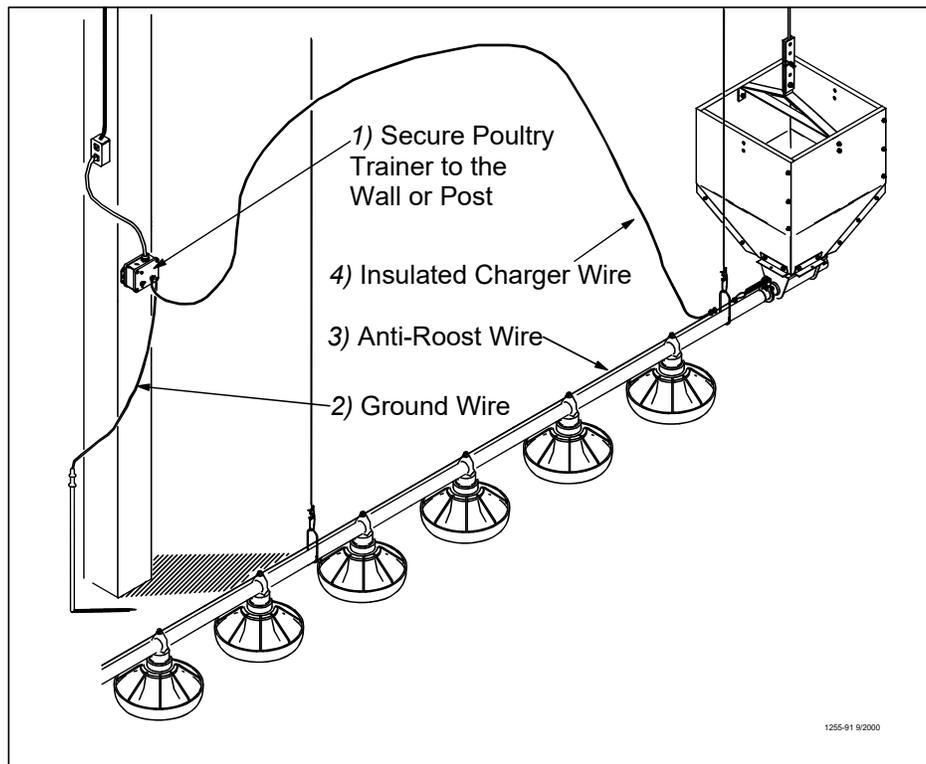

Figure 53. Poultry Trainer Installation

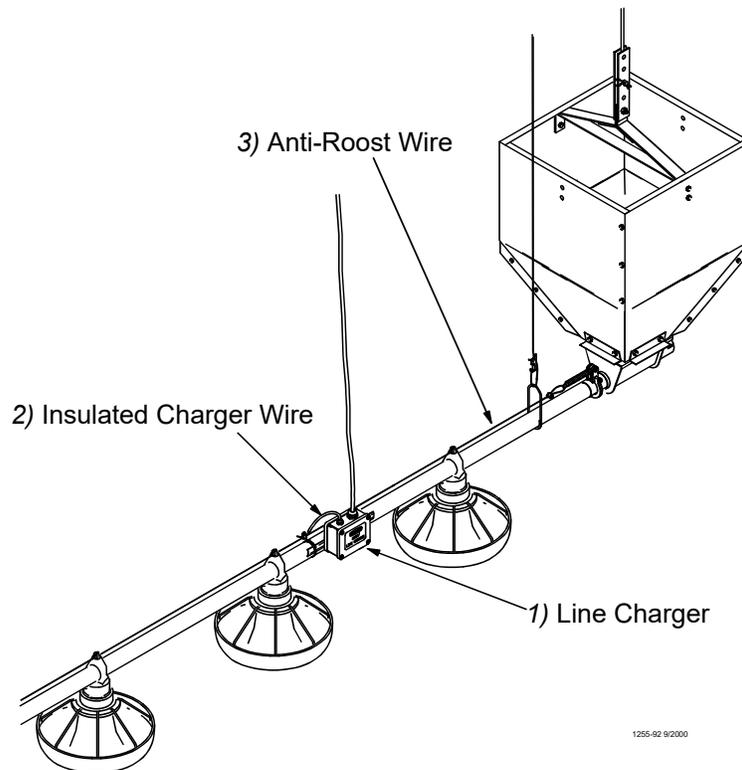

Figure 54. Line Charger Installation

12. The **anti-roost system** *must* be on a **separate electrical circuit**, allowing the system to be disconnected by a **switch near the door**.

Remember, the anti-roost system should be **grounded through the poultry trainer**.

## Feeder Management

**These recommendations are guidelines to aid producers in developing a feeding program. Many factors such as feed content, type of bird, etc. may dictate change from these recommendations.**

Start young birds with the feeder pans resting on the floor. The Model C2 has the ability to fill the feeders while setting on the floor or suspended. With the feed windows open, feed will spill out in the pan, making it easier for the birds to find feed, adapt to the feeder, and begin to eat. Make sure all the feed windows are in the same position, OPEN or CLOSED.

Raise the feeder as the birds grow. This will automatically close the feed windows, unless they are locked open. Chore-Time recommends opening the feed windows in the pans for the first 5 to 10 days, for broilers. Open the feed windows in the pans for the first 10 to 14 days, for turkeys. The feeders will need to be operated at least twice a day for the first 5 days, thereafter pans may need to be resupplied 3 times a day or as birds eat feed level down.

### **DO NOT RUN THE SYSTEM ON AUTOMATIC (FULL FEED) WHEN FEED WINDOWS ARE OPEN.**

In most cases, setting the feeder to position #4 is recommended. However, feed texture, fat content, type of bird, or some other variables may make it necessary to change to another setting. The combination of proper pan height, feeder setting, and time clock operation, will result in optimum feeder performance. The operator will learn what works best for his/her situation by experience.

Keeping the pans at the proper height prevents birds from raking feed excessively. Proper pan height also reduces feed wastage, improves feed conversion, and provides more income for the producer.

After the birds are through the brood stage, the lip of the pan should be raised to approximately 1" (25 mm) below where the bird's neck enters the breast, as shown below.

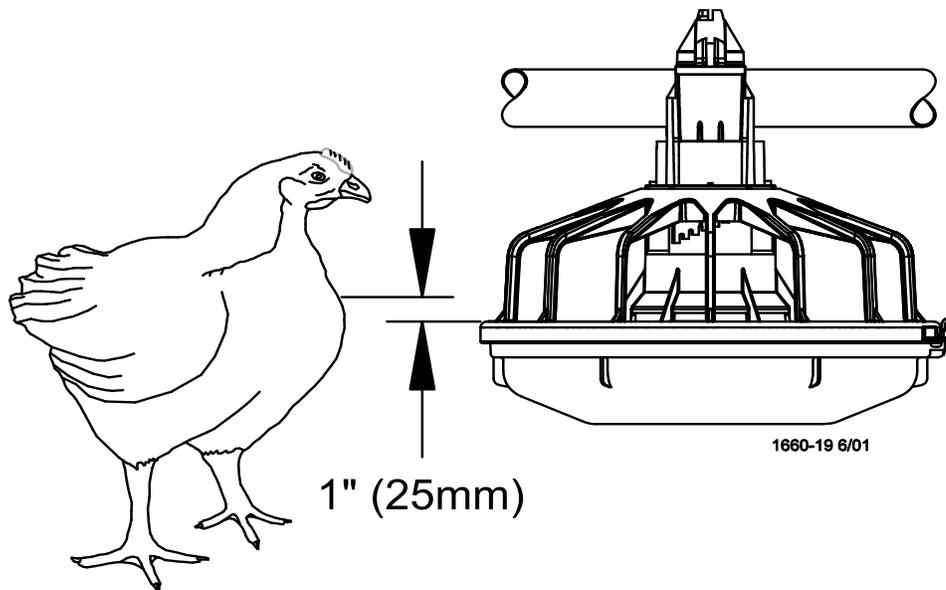

## Maintenance

### Floor Feeding System Maintenance

The Model C2 Plus and Model G Plus Feeders require minimum maintenance. However, a routine periodic inspection of the equipment will prevent unnecessary problems.

Maintenance should be done by a qualified technician.

**ALWAYS DISCONNECT POWER TO THE SYSTEM WHEN SERVICING OR MAINTAINING THE EQUIPMENT. FAILURE TO DISCONNECT POWER MAY CAUSE INJURY OR DEATH.**

### Gear Head Maintenance

Refer to **Figure 55**.

Check the oil level in the gear heads at installation and every 6 months. The Pipe Plug, on the side of the gear head, indicates proper oil level. Add SAE 40W oil when necessary.

The oil in the gearheads should be replaced every 12 months with new SAE 40W oil

- A. Remove the bottom Pipe Plug to drain the oil. Discard used oil in accordance with local and national codes.
- B. Wipe any debris off the magnet on the bottom Pipe Plug and reinstall. Remove the side Pipe Plug and (top) Vent Plug.
- C. Set the power unit in the horizontal position.
- D. 2-Stage Gearheads: Add approximately 9 oz. (266 ml) of SAE 40W oil through top hole. This should be just enough oil to reach the side Pipe Plug.  
3-Stage Gearheads (3261-9, 3261-12, 3261-14): Add approximately 13 oz. (384 ml) of SAE 40W oil through top hole. This should be just enough oil to reach the side Pipe Plug.
- E. Install the side Pipe Plug and (top) Vent Plug.

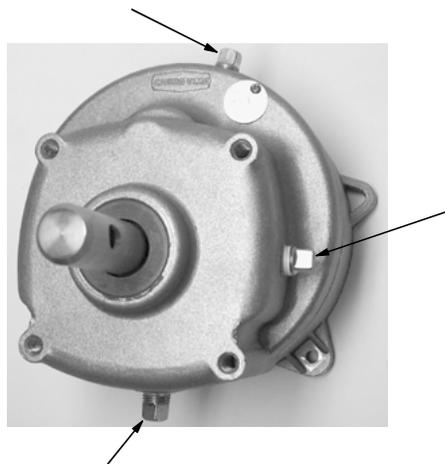

**Figure 55. Gearhead Maintenance**

Check equipment for loose hardware after the first flock and then every 6 months--including the Anchor Block. Tighten if necessary.

## Mechanical Switch Adjustment procedure for Control Units

Refer to **Figure 56**.

- A. Turn the adjustment nut counter-clockwise until the switch clicks.
- B. Turn the adjustment nut clockwise until the switch clicks.
- C. Turn the adjustment nut counter-clockwise 3/4 turn.

1) Adjustment Nut



Figure 56. Switch Adjustment

## SENSOR PLUS Sensor Switch Adjustment for Control Units

Refer to **Figure 57**.

The SENSOR PLUS Pan Half Round Sensor Switch is adjusted at the factory to a sensitivity of .125" from the face of the sensor and a time delay of 15 seconds, the time delay adjustment is 0 seconds to 600 seconds.

To adjust the Time Delay:

- For less time — turn Time Delay Adjusting Screw counter-clockwise (Light blinks fast)
- For more time — turn Time Delay Adjustment Screw clockwise (Light blinks slow)

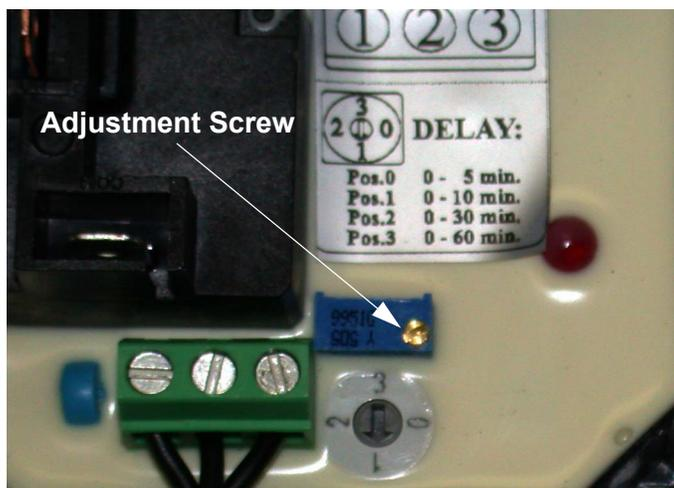

Figure 57. Adjusting the SENSOR PLUS Proximity Switch

## Feeder Line

Keep anti-roost cables tightly stretched. This increases the effectiveness of the electro-guard anti-roost system and keep the pans from being tilted when birds push against them.

Remove all feed from the feeder when there are no birds in the house and when the building is washed and disinfected.

Turn the feeders off prior to removing the birds from the house. This will allow them to clean the feed out of the pans.

If the system is not to be used for an extended period of time, remove all the feed from the feeder lines and feeder pans.

Disconnect power to the system to prevent accidentally starting the system.

If the system must be disassembled, extreme caution must be used to prevent injury from springing auger. Refer to **Figure 58**.

1. Disconnect power to the entire system.
2. Loosen the Tube Clamp on the bearing at the hopper end of the system. Remove the Tube Clamp and Bearing Retainer.
3. Pull the Anchor and Bearing Assembly and approximately 18" [45 cm] of auger out of the boot.

**CAUTION: Stand clear...the auger may spring back into the tube.**

4. Place a clamp or locking plier securely on the auger to prevent it from springing back into the auger boot.
5. Loosen the setscrew in the bearing assembly shaft and remove the Anchor and Bearing Assembly from the auger.

### To reinstall the Anchor and Bearing Assembly:

1. Insert the Anchor Assembly into the auger, guide the tip of the auger between the two roll pins in the center of the anchor. Continue to guide the auger until the tip of the auger hits the flat washer. Tighten the setscrews in the center of the anchor until they touch the auger. See **Figure 58**.
2. **Carefully** remove the locking pliers while holding onto the Anchor and Bearing Assembly and auger securely.

**Slowly** ease the auger back into the tube. Use caution.

If the auger is allowed to spring back, the bearing race may crack.

Install the Bearing Retainer and fasten with a tube clamp. Keep the Bearing Retainer flush with the end of the anchor for safety.

## Power Lift Winch Maintenance

Refer to **Figure 59**.

Grease the winch every 6 months with 1 to 2 shots of common industrial or automotive grease. **DO NOT OVER GREASE THE WINCH.**

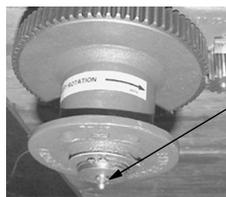

- 1) Grease the Power Lift Winch every 6 months with 1 to 2 shots of common industrial or automotive grease **DO NOT OVER GREASE THE POWER LIFT WINCH**

1600-24 6/2001

**Figure 59. Maintenance to the Power Lift Winch**



Remove any feed build-up in the Safety Switch Boxes in the Control Units.

It may be necessary to periodically retighten the shocker cable. Be sure to disconnect power to the shocker before servicing the equipment.

# Trouble Shooting the Floor Feeding System

**ALWAYS DISCONNECT POWER TO THE SYSTEM WHEN SERVICING OR MAINTAINING THE EQUIPMENT. FAILURE TO DISCONNECT POWER MAY CAUSE INJURY OR DEATH.**

Service and maintenance work should be done by a qualified technician only.



Problem	Possible Cause	Corrective Action
None of the feeder lines will operate	No power supplied to equipment	Replace burned fuses or reset circuit breaker Make sure voltage required is supplied
	Time Clock or relay defective	Replace Time Clock or relay
	Time Clock improperly programmed	Refer to Programming the Time Clock section and reprogram the Time Clock
Feeder line will not operate	Power unit cord not plugged in sufficiently to make contact	Check motor cord plug at control unit and control unit plug at outlet for connection
	Motor cord wires are broken at plug or where cord enters motor	Check cord for continuity Replace if defective
	Power Units thermal overload tripped	Push motor overload reset button to reset
	Control unit switch defective or out of adjustment	Adjust switch according to the Switch Adjustment Procedure in the maintenance section
Motor overloads frequently	Oil on new auger loads motor excessively when feed is carried for first time	Polish auger by running 50 lb (20 kg) increments of feed out to pans
	Inadequate power reaching motors	Check line voltage at the motors Check starting current draw at motors Wiring of adequate size is essential to feeder operation
	Object caught in the auger; motor runs, stalls, then auger spins in reverse	Check hopper boot, control unit and pan outlet holes for foreign objects Remove obstruction
Auger runs erratically	Frozen or cracked bearing at boot anchor	Replace bearing Slowly ease auger back into tube Be careful not to damage the bearing when reinserting the auger
	Insufficient stretch in auger	Shorten the auger
	Obstruction in the auger	Remove obstruction
Auger tube or boot wears out rapidly (Noisy feeder operation)	Auger is bent or kinked	Repair or replace damaged auger
	End of auger is riding up on anchor weldment	Auger must not be positioned over weld on anchor Check for bent or damaged auger
Oil leaking out of seals on power unit	Gearhead vent plug not installed	Replace plastic shipping plug with vent plug
	Defective gear head seal	Replace seal
Not enough feed supplied to the feeder pans	Insufficient time programmed on the time clock	Add more operating time to feeding period
	Feeder line control unit switch out of adjustment	Adjust switch according to the Switch Adjustment Procedure in the maintenance section

# Wiring Diagrams

## Winch Control Wiring Diagram with 29820-3 Tower Limit Switch

37215 MULTI-LIFT Winch with 34812 Winch Control  
and 29820-3 Tower Limit Switch

or

14560 or 14580 Electric Power Winch with 34812 Winch Control  
and 29820-3 Tower Limit Switch

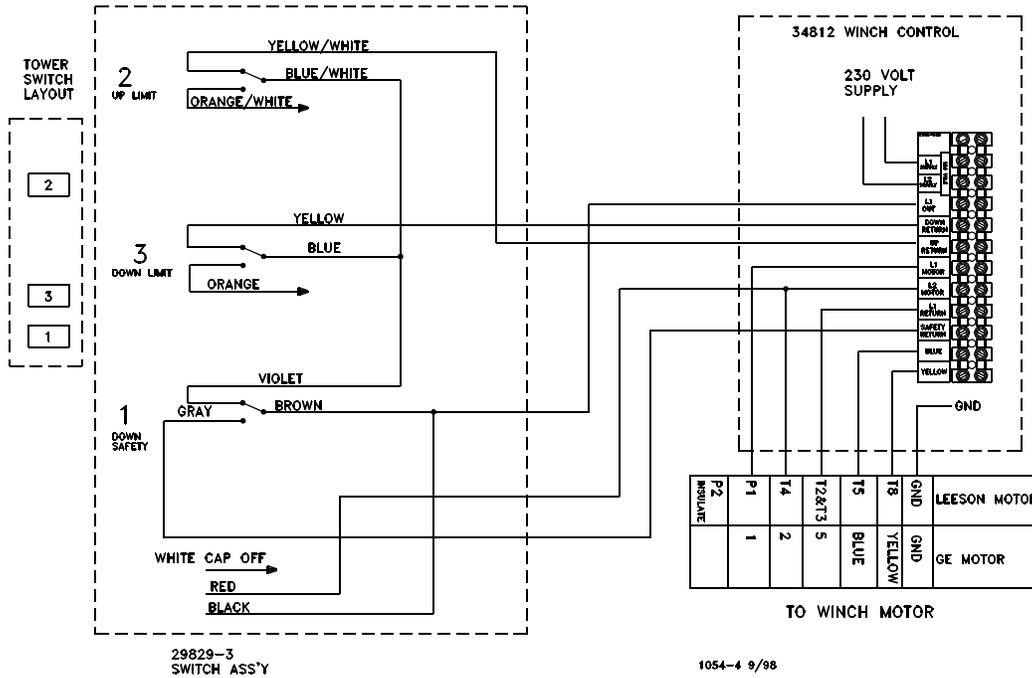

## Winch Control Wiring Diagram with 39464 Limit Switch

37215 MULTI-LIFT with 34812 Winch Control and 39464 Limit Switch

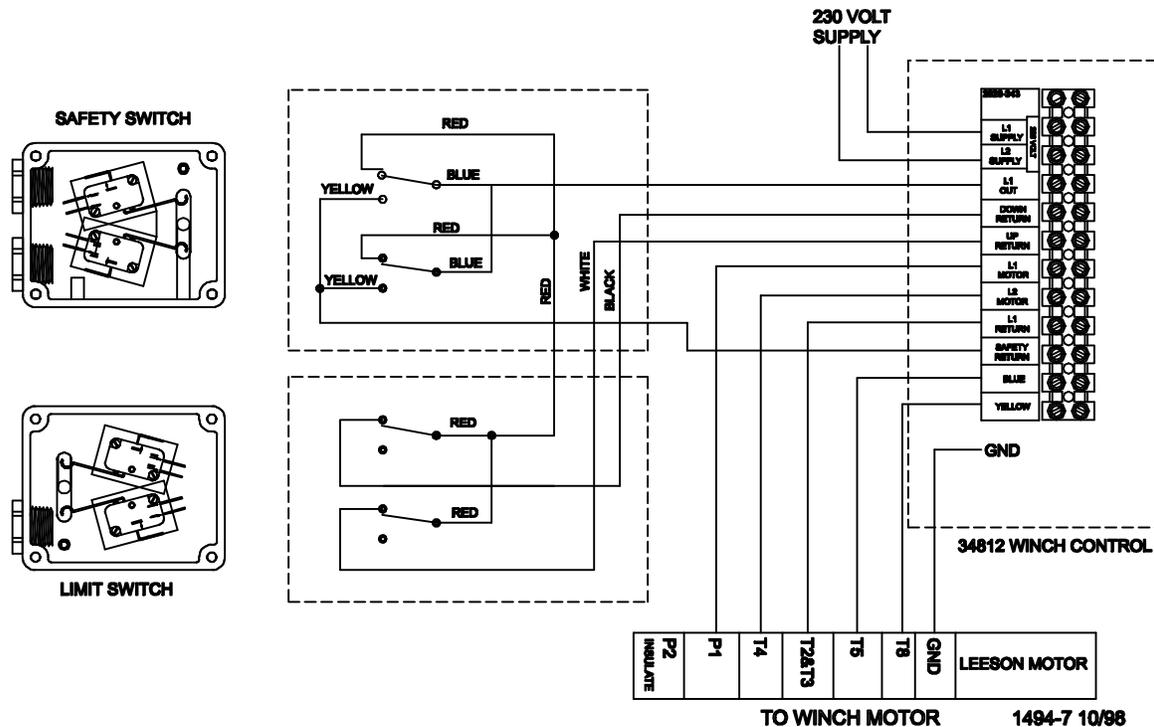

# Male Feeder System Wiring Diagrams: Single Phase(Ø)

## Single Phase(Ø) Wiring Diagram

FROM DISCONNECT OR  
CONTROL DISCONNECT  
220/230 VOLTS 50/60 HZ.

SINGLE PHASE WIRING DIAGRAM

FEEDER LINE MOTOR  
220/230 VOLTS 50/60 HZ.  
SINGLE PHASE

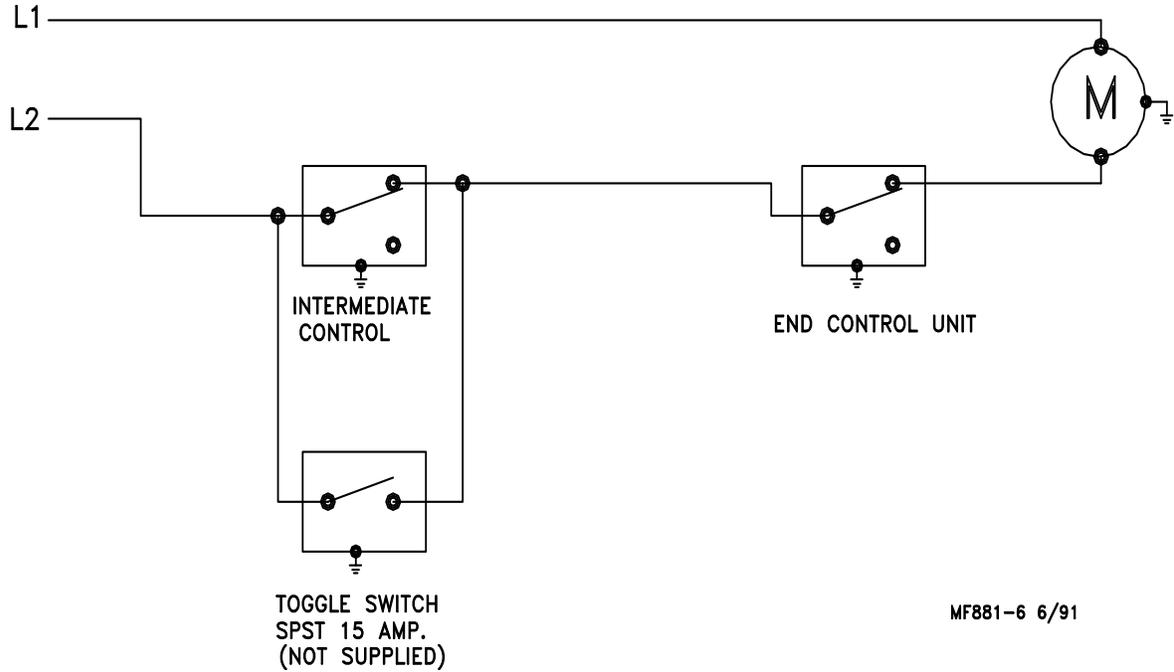

MF881-6 6/91

## Single Phase(Ø) Wiring Diagram: w/Motor Starter

SINGLE PHASE

FROM DISCONNECT OR  
CONTROL DISCONNECT  
220/230 VOLTS 50/60 HZ.

TO ADDITIONAL  
FEEDER LINES

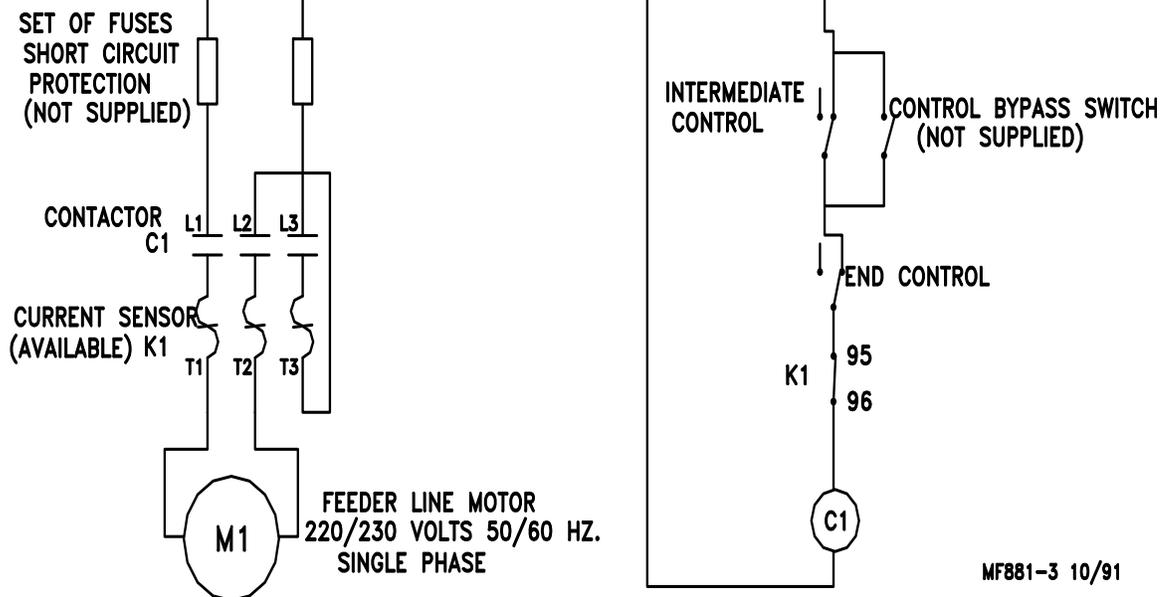

MF881-3 10/91

# Male Feeder System Wiring Diagrams: Three Phase(Ø)

## Three Phase(Ø) Wiring Diagram: 220/230 V

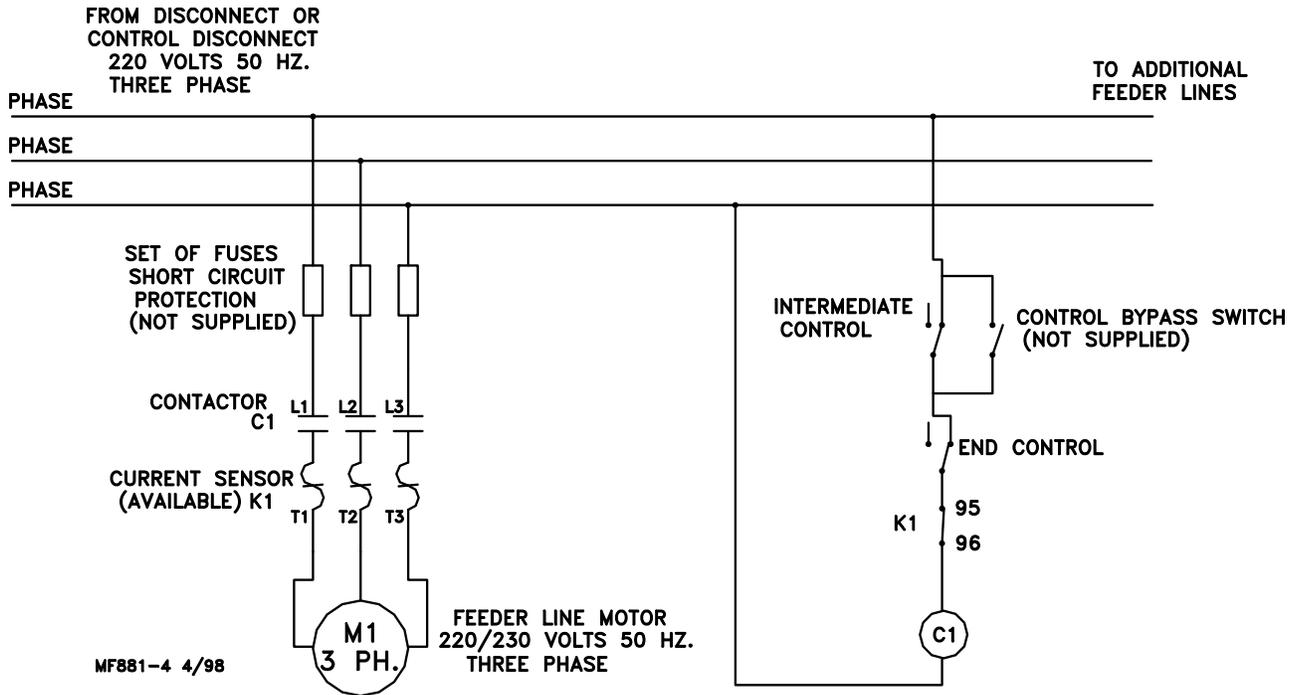

## Three Phase(Ø) Wiring Diagram: 380/415 V

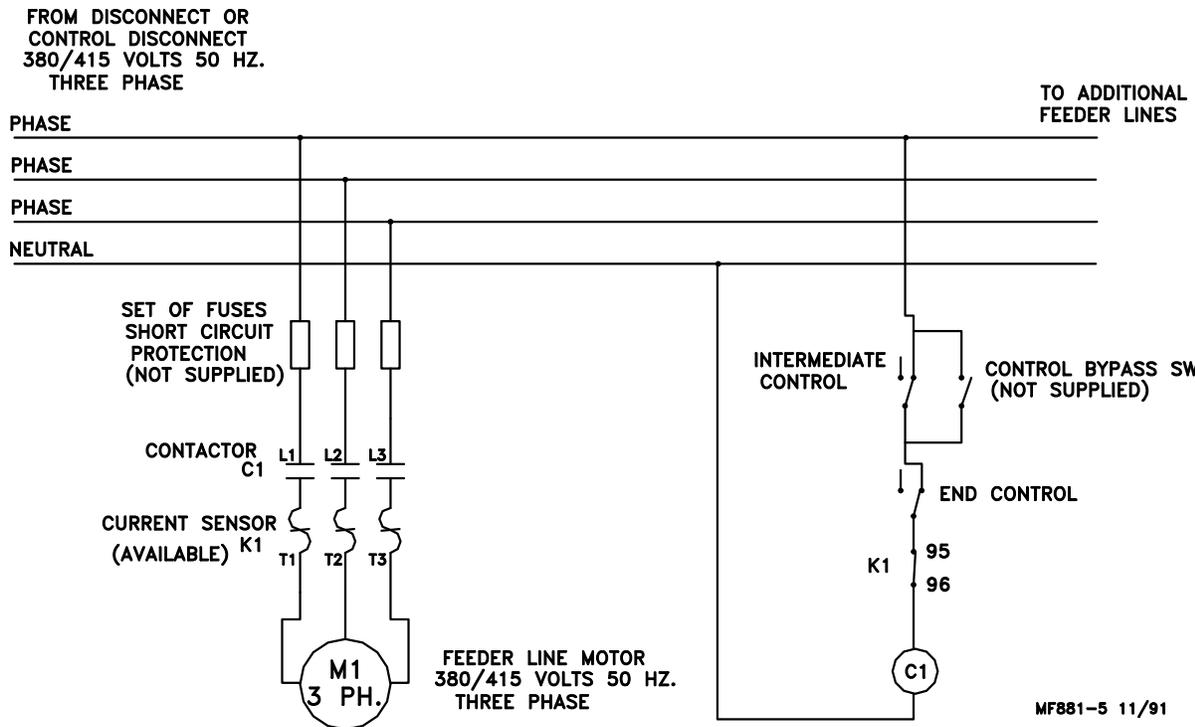

# Electric Power Lift Wiring Diagram

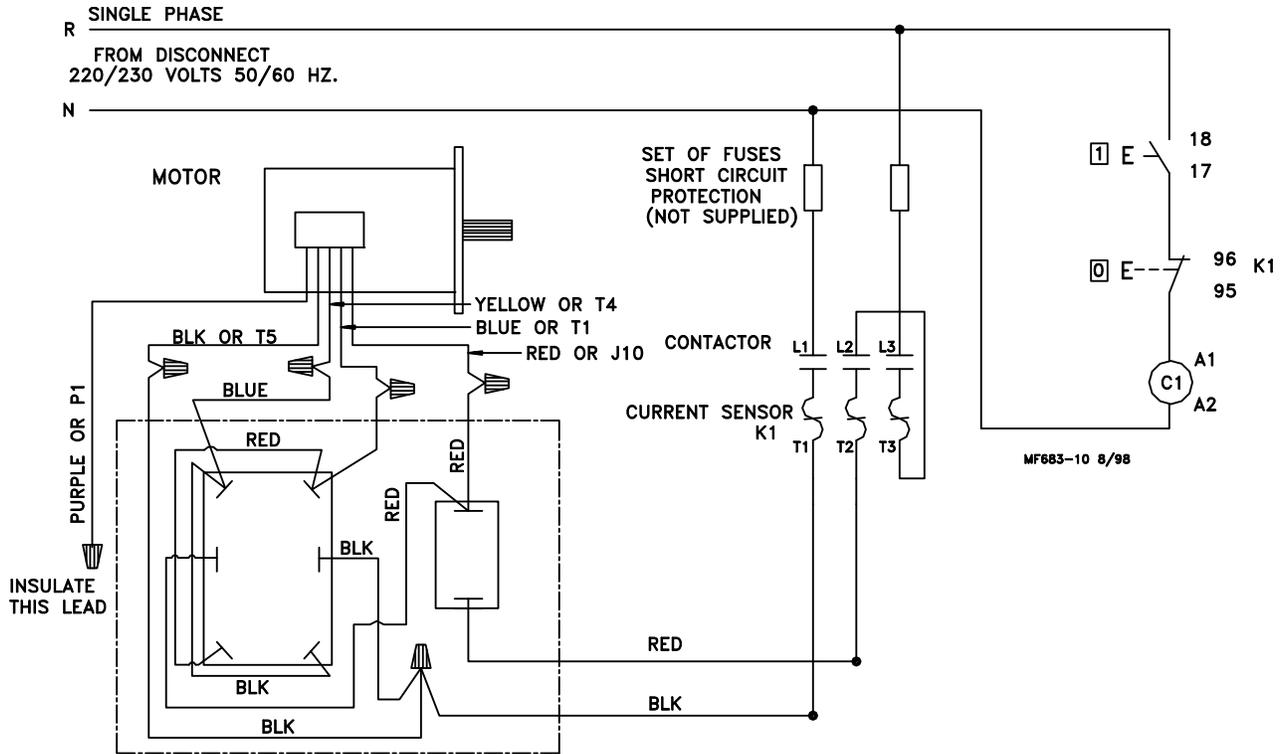

# Parts Listing

## Standard Breeder Pans

### Standard Breeder Pans

STANDARD BREEDER PAN  
W/WINDOWS, & REDUCTION  
TUBE

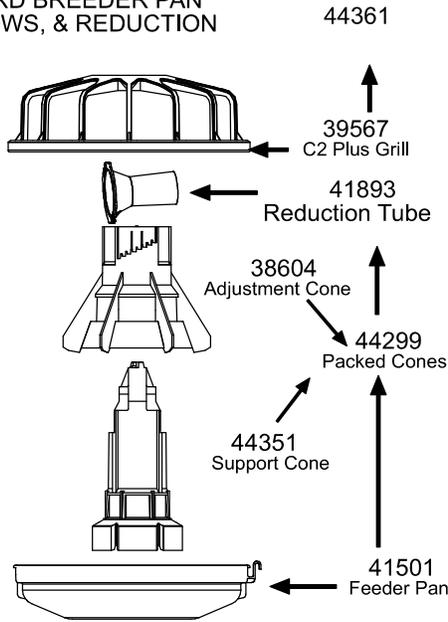

STANDARD BREEDER PAN  
NON-WINDOW, & REDUCTION  
TUBE

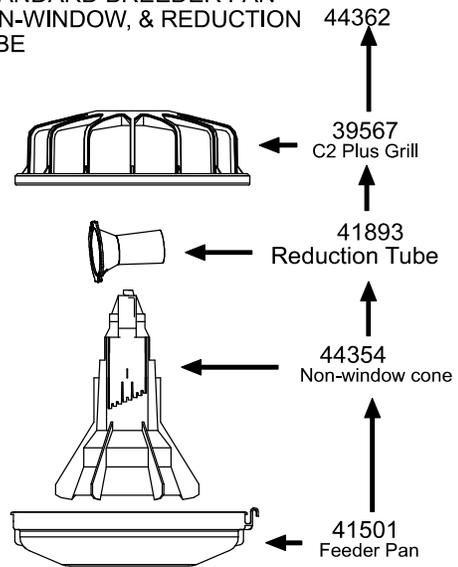

STANDARD BREEDER PAN  
W/WINDOWS, REDUCTION TUBE, &  
REM. TOP

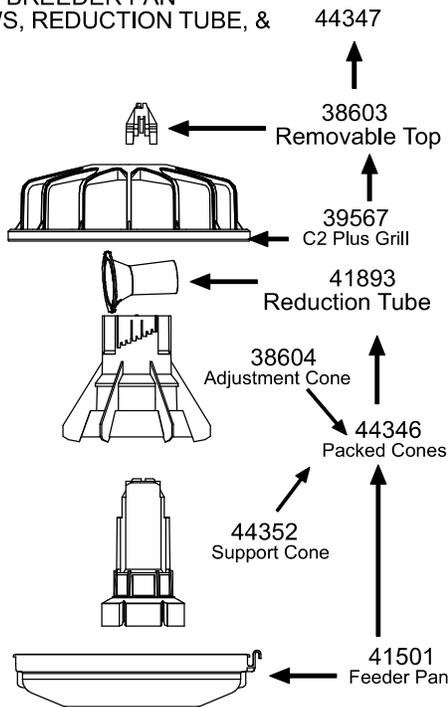

STANDARD BREEDER PAN  
NON-WINDOW, REDUCTION  
TUBE & REM. TOP

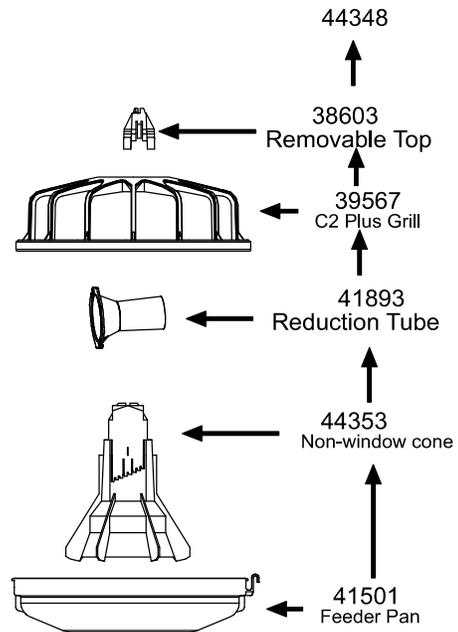

DEPBRED1.fn5  
tjc 01/02/01

Standard Breeder Pans with Shut-Off

# Standard Breeder Pans WITH SHUT-OFF

STANDARD BREEDER PAN  
W/WINDOWS, W/SHUT-OFF  
&REDUCTION TUBE

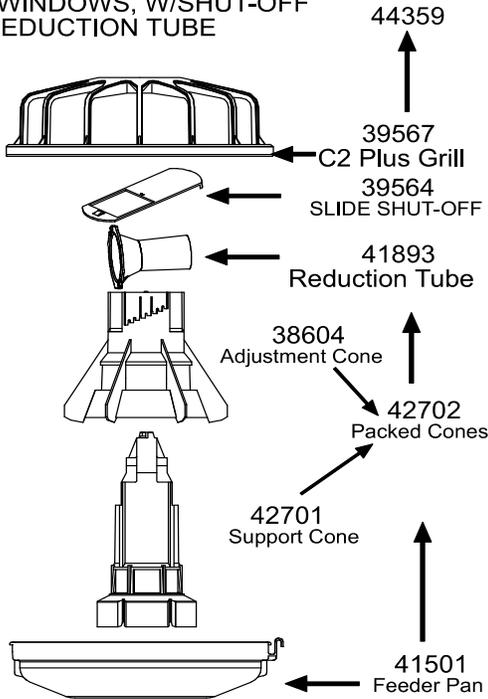

STANDARD BREEDER PAN  
NON-WINDOW, W/SHUT-OFF  
& REDUCTION TUBE

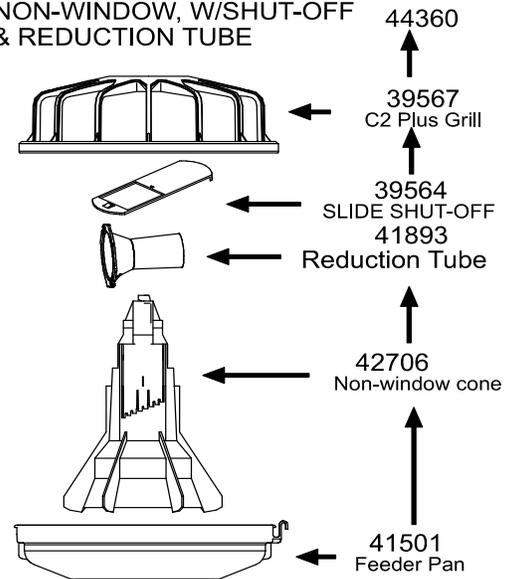

STANDARD BREEDER PAN  
W/WINDOWS, W/SHUT-OFF,  
REDUCTION TUBE & REM. TOP

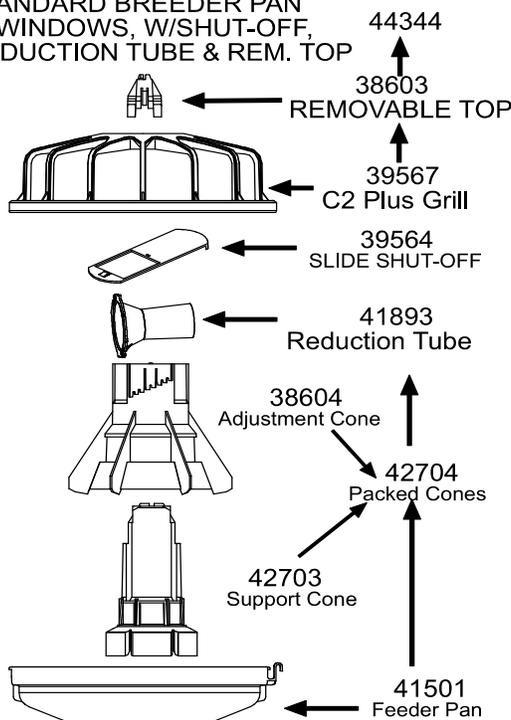

STANDARD BREEDER PAN  
NON-WINDOW, W/SHUT-OFF,  
REDUCTION TUBE & REM. TOP

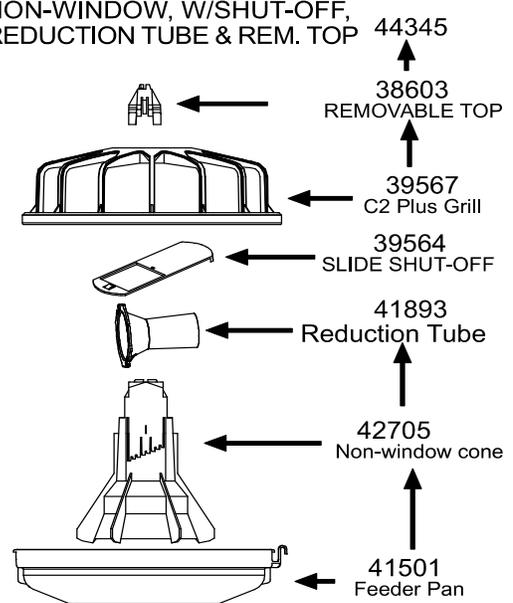

DEEPBRED.fh8  
tjc 01/02/01

# Shallow G™ Plus Breeder Pans with Slide Shut-Off

## Shallow G PLUS Breeder Pans

with Slide Shut-off

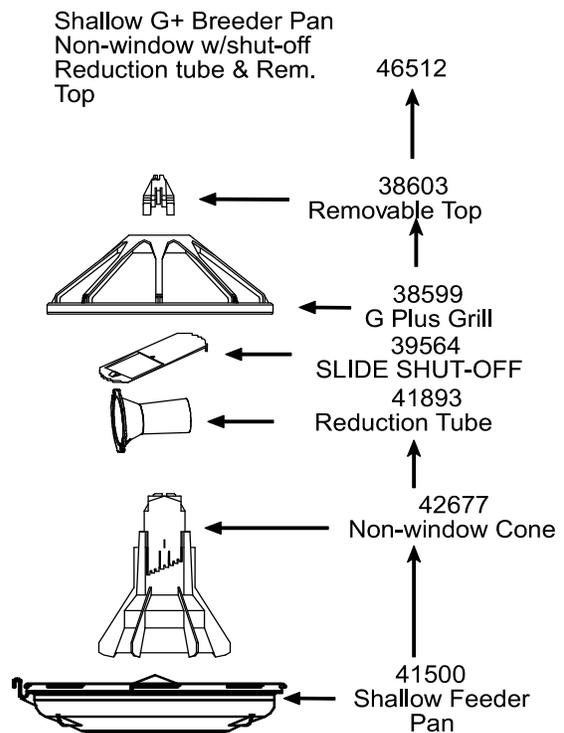
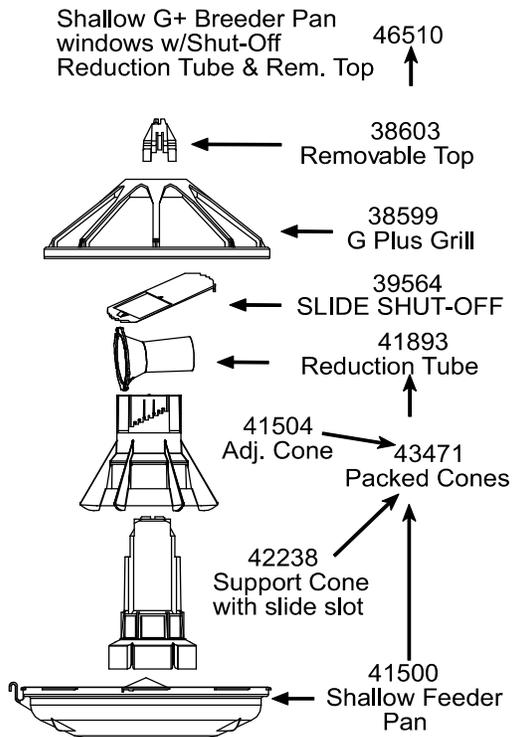
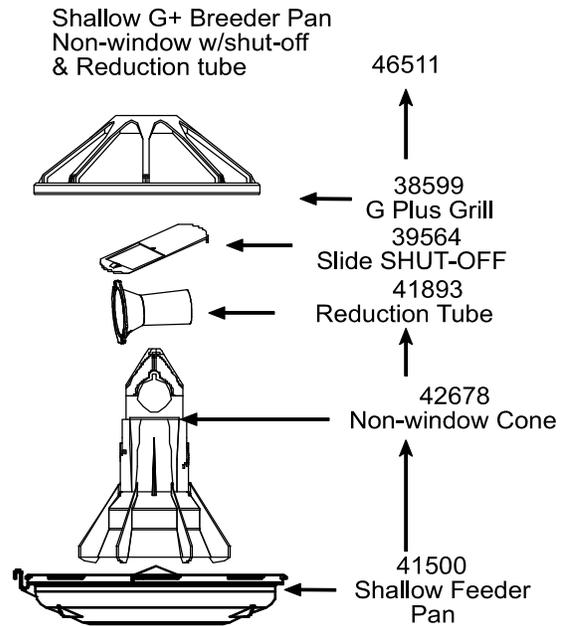
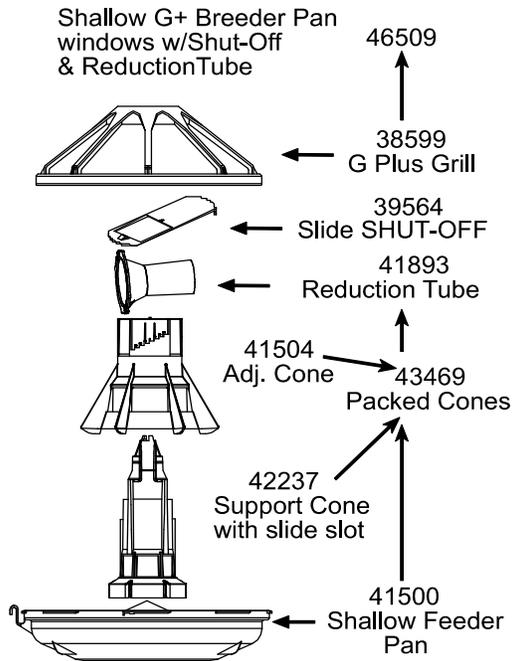

x:/G+shlbred.fh8 tjc 11/13/00

Shallow G™ Plus Breeder Pans

Shallow G PLUS Breeder Pans

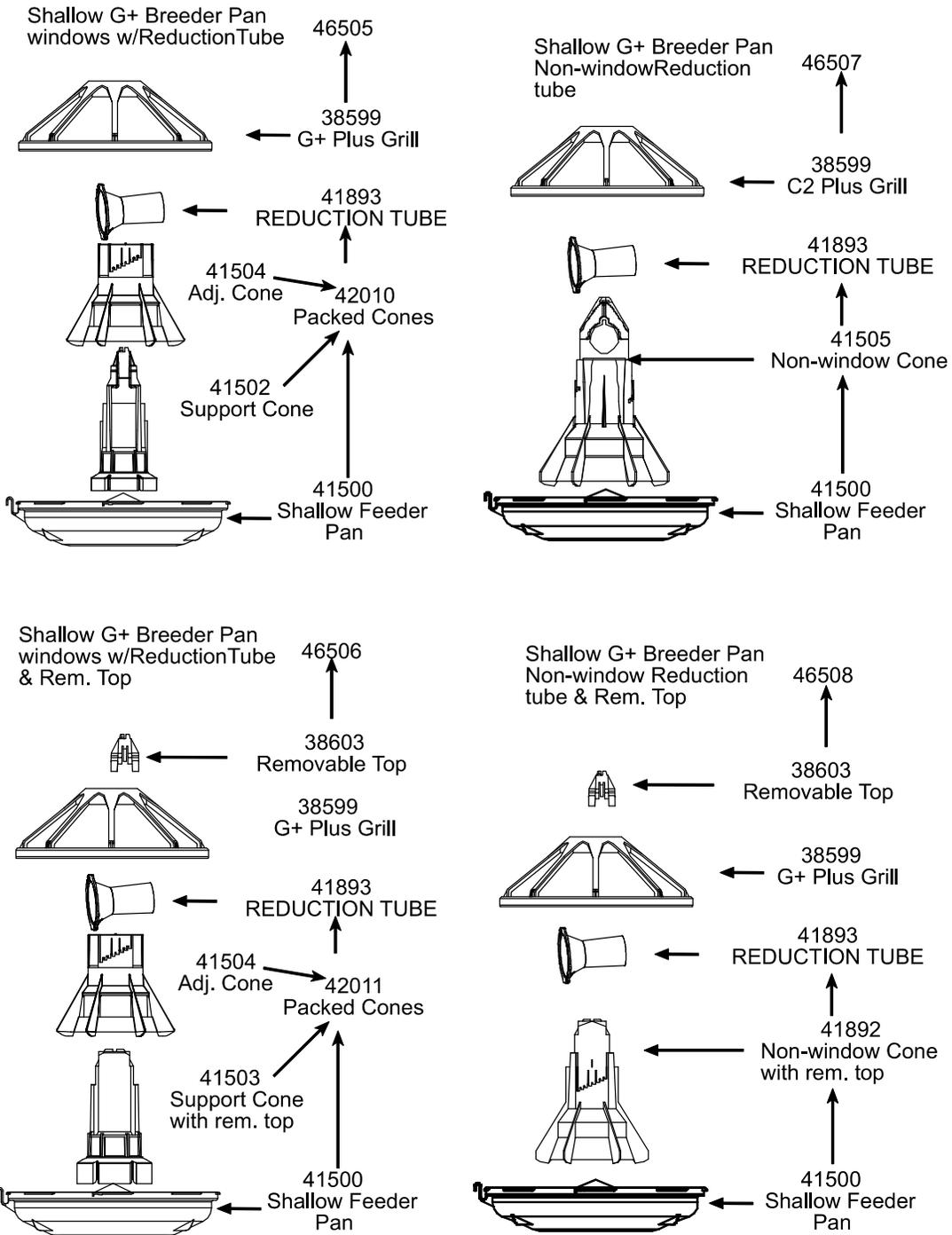

G+shldbrd1.fh8  
tjc 01/02/01

# Shallow Breeder Pans

## Shallow Breeder Pans

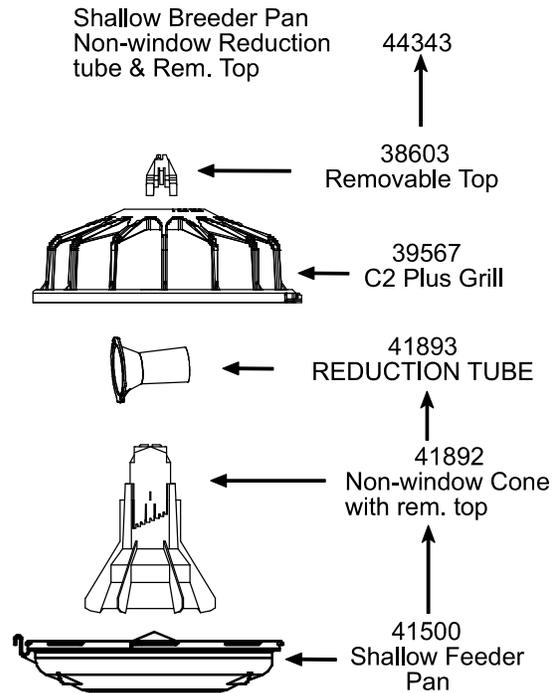
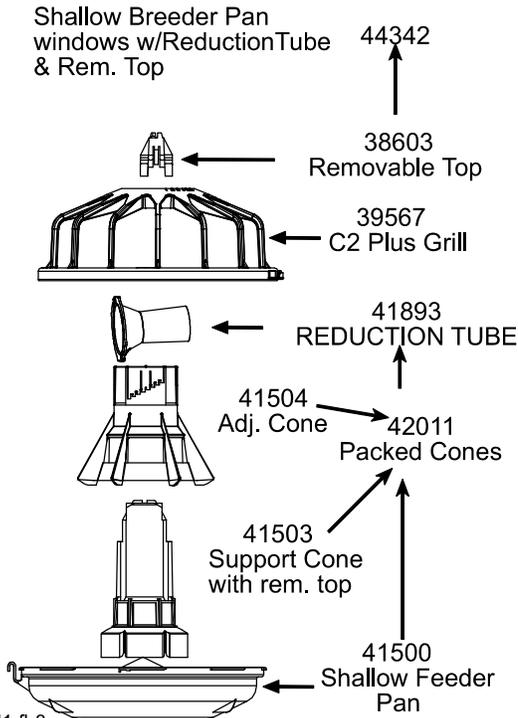
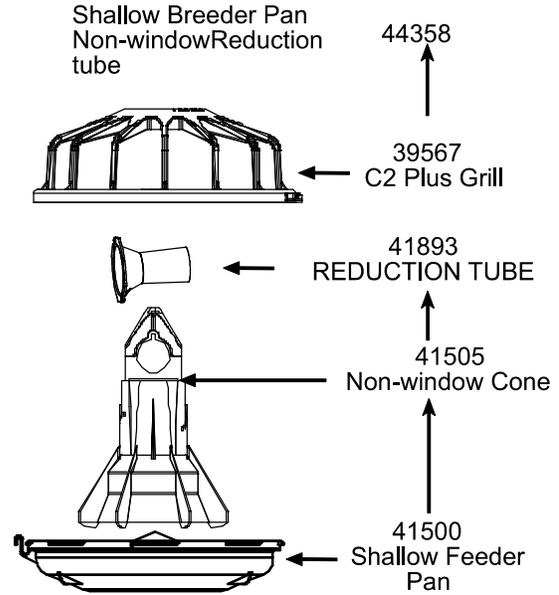
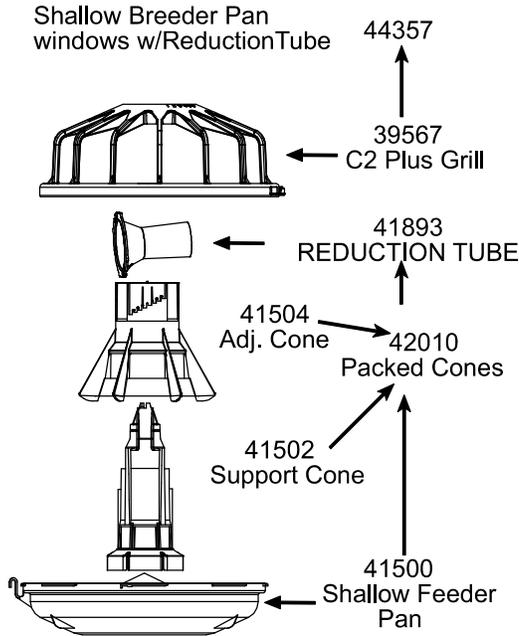

shldbrd1.fh8  
tjc 11/10/99

### 34812 Winch Control Parts Listing

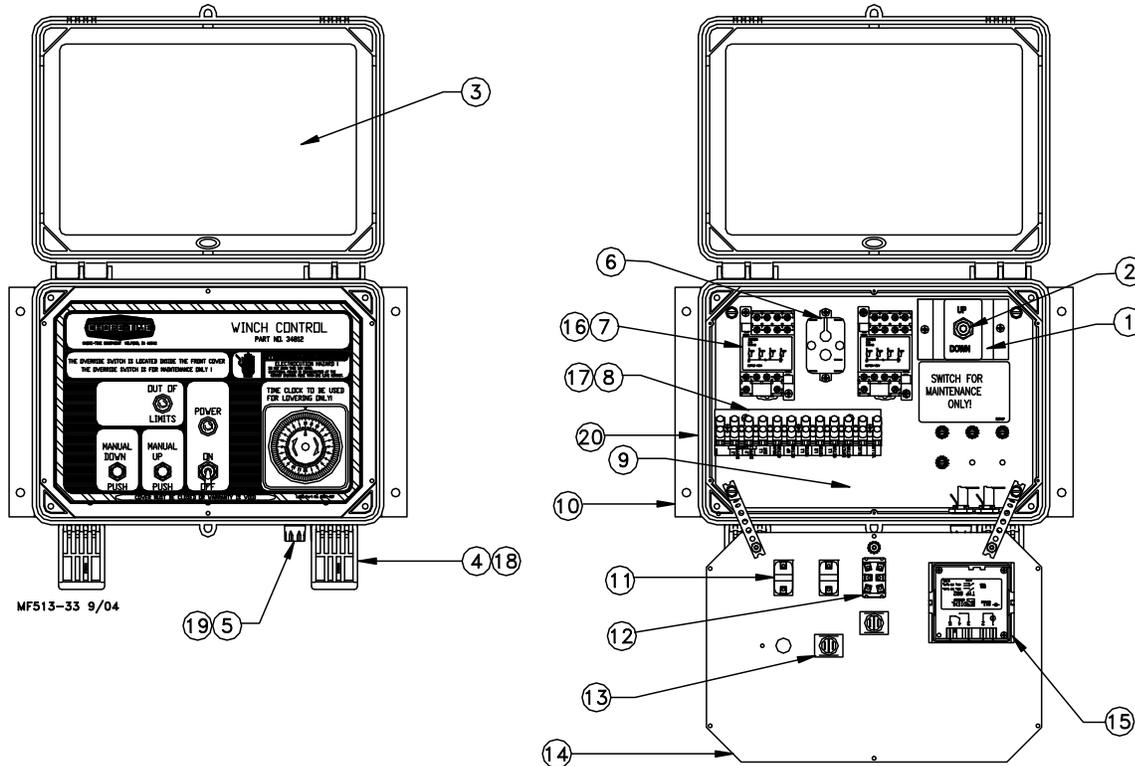

Item	Description	Part No.
1	Switch Bracket	46846
2	Toggle Switch (DPDT)	46847
3	Clear Lid	30859-1
4	Control Box Latch	30862
5	Fuse Holder	24431
6	Relay	5574
7	4 PDT Relay (230 V)	34910
8	Terminal Mount Bracket	34563
9	Back Mount	34383
10	Control Box Mount Panel	34852

Item	Description	Part No.
11	Momentary Switch	5785
12	Toggle Switch	6014
13	Pilot Light	7044
14	Winch Control Panel	34382
15	Time Clock	34912
16	Track Mounting Socket	34909
17	Terminal Strip	34925
18	Control Box Latch Pivot	30863
19	10 Amp Fuse	7350
20	Control Box	34985

### 14613 Switch Box Assembly

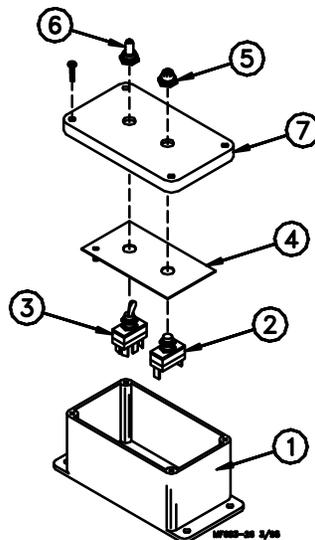

Item	Description	Part No.
1	Box	42610
2	Momentary Switch	5785
3	Toggle Switch	20135
4	Grounding Plate	14604
5	Toggle Switch Boot	1739
6	Push Button Boot	20784
7	Cover	40904

# 8798 Switch Assembly

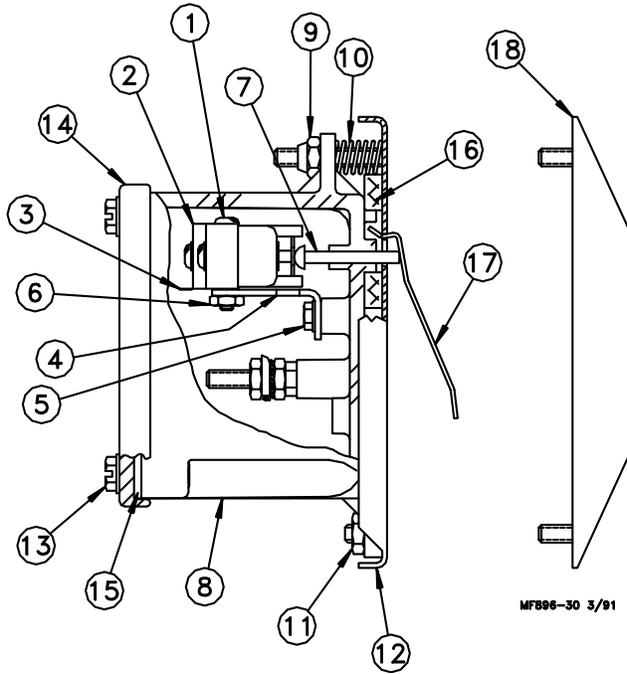

Item	Description	Part No.
1	6-32 x 7/8" Rd. Hd. M.S.	1921
2	SPDT Actuator Switch	7114
3	Switch Insulation	1907-5
4	Switch Bracket	7068
5	#6 x 3/8" Slot Wash. Hd. Screw	6782
6	6-32 Hex Nut	771
7	Pin	8757
8	Switch Box	7841
9	10-32 Hex Lock Nut	6963
10	Spring	6972
11	10-32 Hex Nut	4297
12	Mounting Plate	7908
13	#10 Twin Helix Screw	6980
14	Switch Box Cover	6776
15	Gasket	6777
16	Gasket	6968-1
17	Paddle	7896
18	Diaphragm Assembly	7900
--	Deflector	28281

# Mechanical End Control

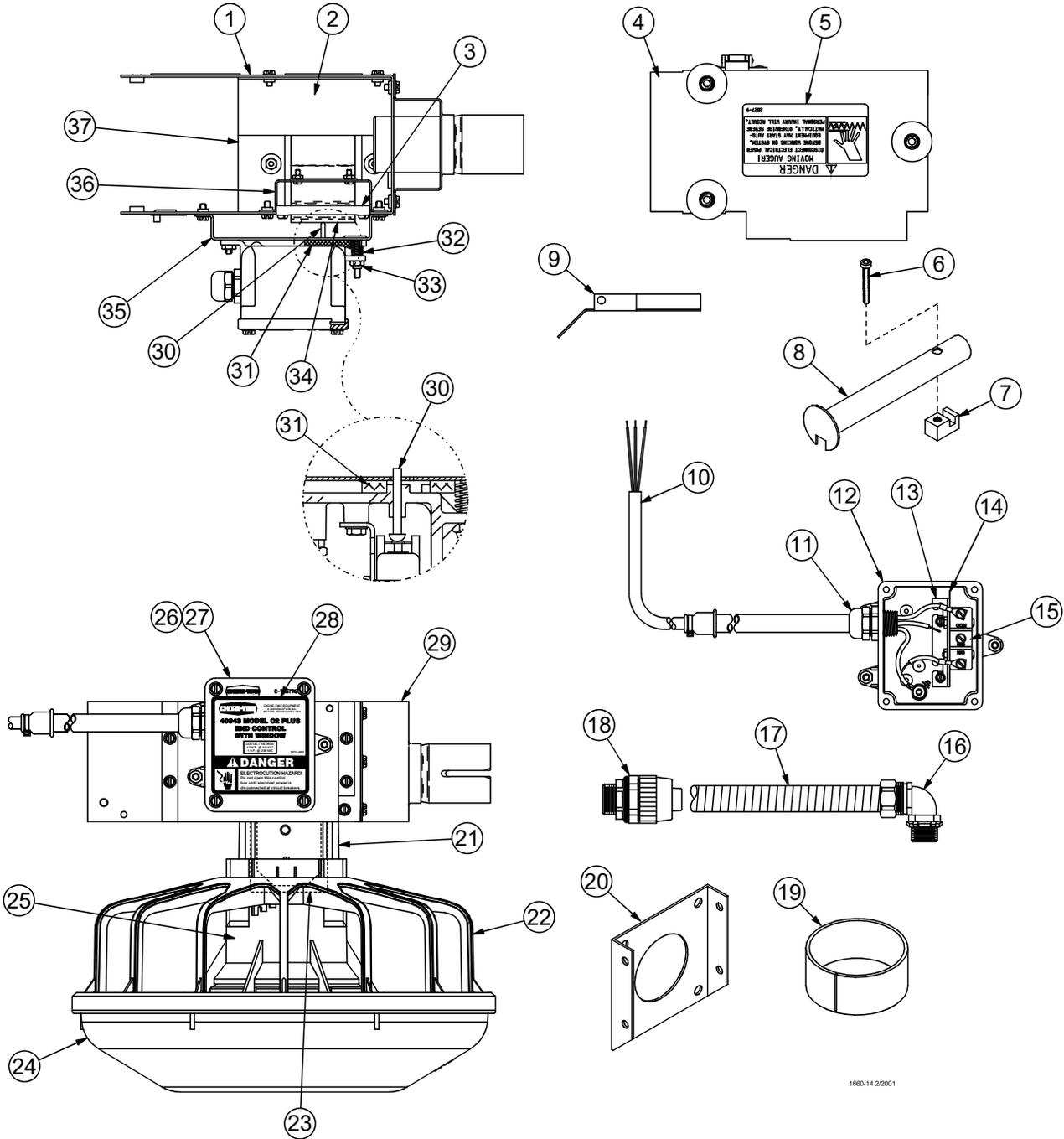

1660-14 2/2001

Item	Description	MODEL C2 Plus Standard Part No. 40943	MODEL C2 Plus Shallow Part No. 42012	MODEL G Plus Standard Part No. 40944	MODEL G Plus Shallow Part No. 42028
1	Control Body	14434	14434	14434	14434
2	Deflector Panel	41363	41363	41363	41363
3	Paddle Retainer	25045	25045	25045	25045
4	Control Cover Assembly	24682	24682	24682	24682
5	Danger Decal	2527-9	2527-9	2527-9	2527-9
6	1/4-20x1-1/2 Socket Hd Screw	5083-8	5083-8	5083-8	5083-8
7	Driver Block	4642	4642	4642	4642
8	Drive Tube Weldment	44794	44794	44794	44794
9	Bottom Cover	14432	14432	14432	14432
10	Control Cord Assembly	25495	25495	25495	25495
11	1/2" Liquid Tight Connector	24685	24685	24685	24685
12	Switch Box	24702	24702	24702	24702
13*	Switch Bracket	46122	46122	46122	46122
14*	Switch Insulation	1907-5	1907-5	1907-5	1907-5
15**	Actuator Switch	46091	46091	46091	46091
16	1/2" Liquid Tight Connector	23810	23810	23810	23810
17	14" Flexible Conduit	26982-1	26982-1	26982-1	26982-1
18	Straight Liquid Tight Connector	26980	26980	26980	26980
19	Cut Sleeve	43110	43110	43110	43110
20	Anchor Plate	4188	4188	4188	4188
21	Center Support Assembly	40947	37371	40947	37371
22	Feeder Grill	39567	39567	38599	38599
23	Mylar Assembly	25318	25318	25318	25318
24	Feeder Pan	41501	41500	41501	41500
25	Adjustment Cone	38604	41504	38604	41504
26	Switch Box Cover	6776	6776	6776	6776
27	Switch Box Gasket	6777	6777	6777	6777
28	Danger/Product Identification Decal	2529-660	2529-697	2529-659	2529-698
29	Support Bracket	24683	24683	24683	24683
30	Spring	6972	6972	6972	6972
31	#10-32 Lock Nut	6963	6963	6963	6963
32	Paddle	46123	46123	46123	46123
33	Gasket	6968-1	6968-1	6968-1	6968-1
34	Actuator Pin	8757	8757	8757	8757
35	Switch Box Mount	25084	25084	25084	25084
36	Stop Panel	25433	25433	25433	25433
37	Switch Bracket	40749	40749	40749	40749
--	Anti-Roost Guard	2798	2798	2798	2798
--	Parts Package	40809	40809	40809	40809

\*These items are included in the Parts Package.

\*\*Actuator Switch, Chore-Time part number 7114, is no longer available. When replacing, use 7114 Switch Replacement Kit Part Number 46678.

# Sensor Plus™ End Control

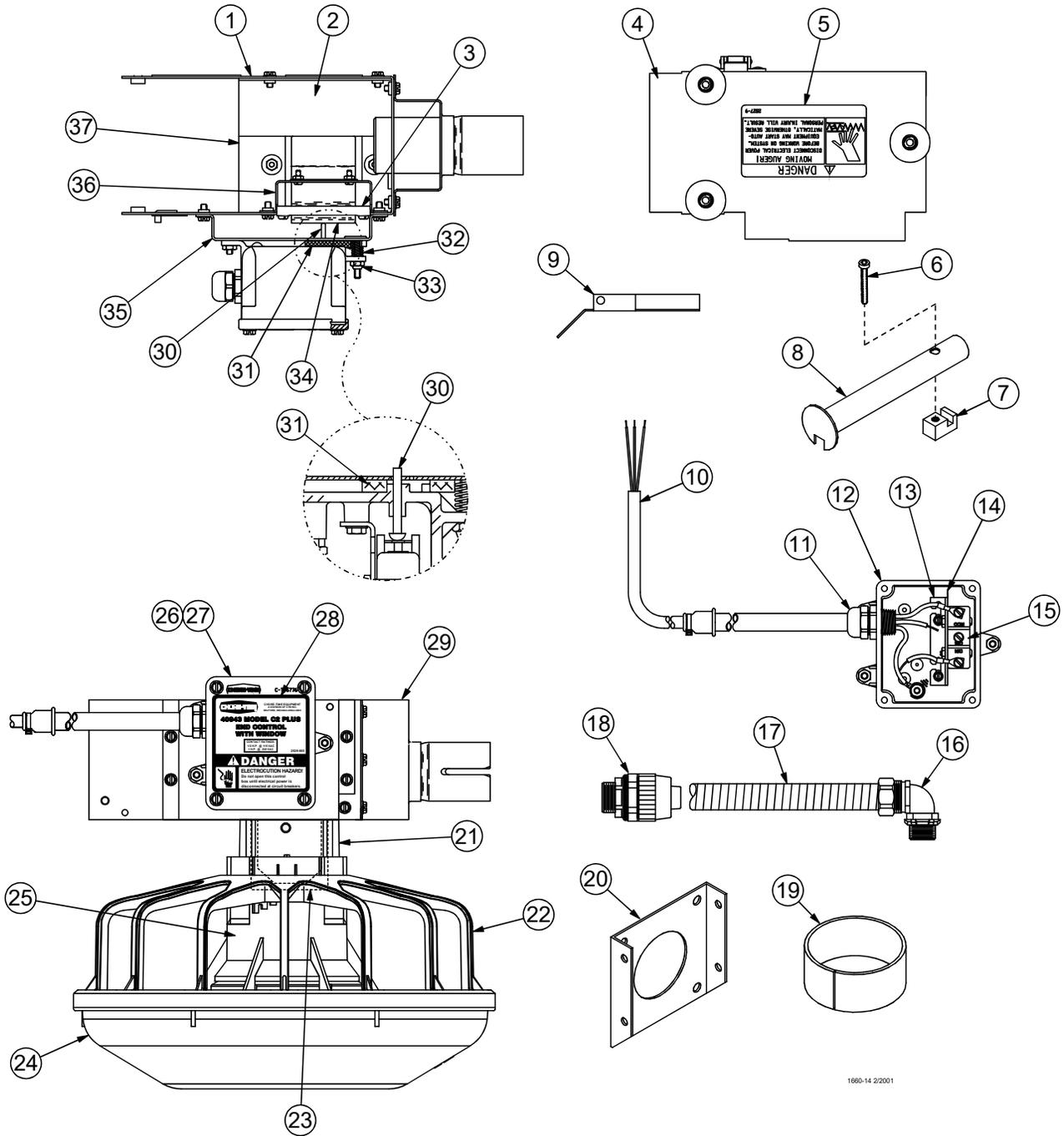

1660-14 2/2001

Item	Description	C2 Plus Standard Part No. 42680	C2 Plus Shallow Part No. 44880	G Plus Standard Part No. 42597	G Plus Shallow Part No. 44882
1	Cut Sleeve	43110	43110	43110	43110
2	Bottom Cover	42085	42085	42085	42085
3	Top Cover with Insulators	42082	42082	42082	42082
4	Driver Block	4642	4642	4642	4642
5	Drive Tube Weldment	44794	44794	44794	44794
6	1/4-20x1-1/2 Socket Hd Screw	5083-8	5083-8	5083-8	5083-8
7	Tube Clamp	24063	24063	24063	24063
8	Support Bracket	42081	42081	42081	42081
9	Terminal Box Mounting Cover	6956	6956	6956	6956
10	Straight Liquid Tight Connector	26980	26980	26980	26980
11	Switch Box Gasket	6777	6777	6777	6777
12	----	----	----	----	----
13	Danger/Product Identification Decal	2529-710	2529-731	2529-709	2529-729
14	Cord Assembly	4999-100	4999-100	4999-100	4999-100
15	Liquid Tight Connector	24685	24685	24685	24685
16	----	----	----	----	----
17	Grill	39567	39567	38599	38599
18	Adjustment Cone	38604	41504	38604	41504
19	Feeder Pan	41501	41500	41501	41500
20	#10 x 1/2 Hex Washer Head Screw	28075	28075	28075	28075
21	General Purpose Terminal Box	42627-3	42627-3	42627-3	42627-3
22	Liquid Tight Connector	23779	23779	23779	23779
23	Control Body Weldment	42080	42080	42080	42080
24	Support Cone	37077	44884	37077	44884
25	Pan Half Round Sensor	48200	48200	48200	48200
26	14" Flexible Conduit	26982-1	26982-1	26982-1	26982-1
27	Liquid Tight Connector	23810	23810	23810	23810
28	Anchor Plate	4188	4188	4188	4188

### Boot Assemblies

Single: Part No. 6822

Twin: Part No. 6824

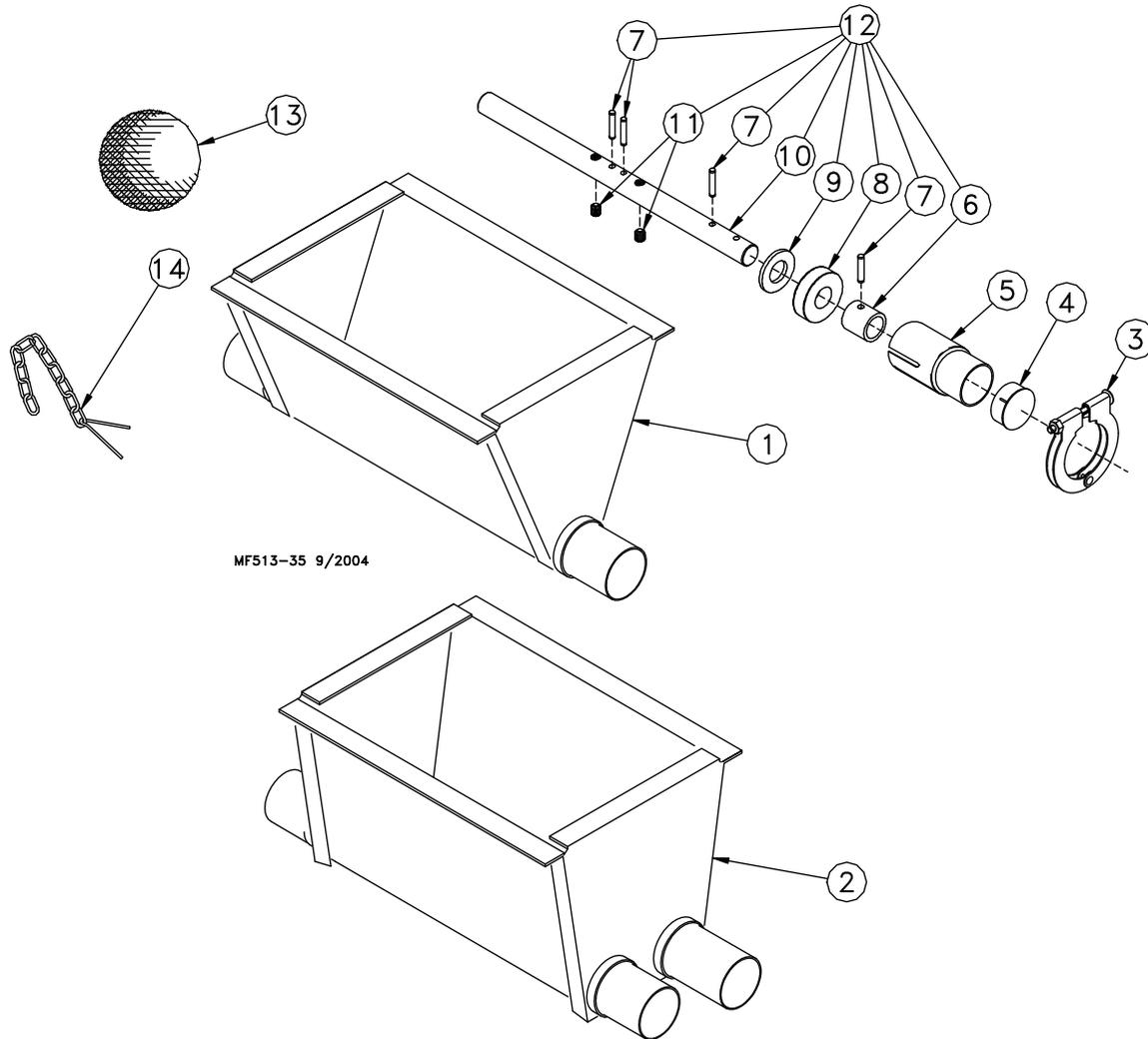

MF513-35 9/2004

Item	Description	Part No.
1	Boot Weldment (Single)	3760
2	Boot Weldment (Twin)	3932
3	Tube Clamp	24063
4	Cap	29373
5	Outlet Tube	4556
6	Sleeve	5648
7	3/16 x 1" Pin	2960-1
8	Bearing	2689
9	Washer	2955-14
10	Anchor	38540
11	Setscrew	47867
12	Anchor and Bearing Ass'y	39372
13	Cannonball	3531
14	Latch Pin Ass'y	2683
--*	Jumper Wire Kit	5960
--	Danger Decal	2527-9

\*The Jumper Wire Kit includes an insulated piece of High-Voltage Wire (part no. 28994) and (2) cable clamps.

### Miscellaneous Suspension Components

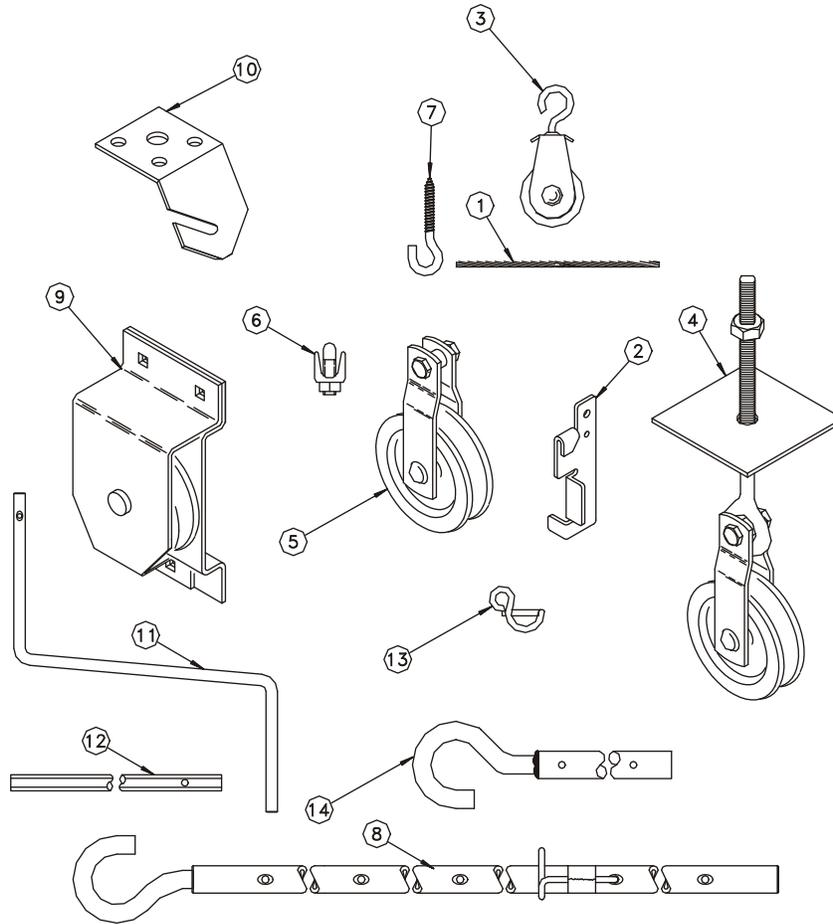

MF232-58 9/96

Item	Description	Part No.
1	3/16" Cable	1213
2	Cable Lock	14337
3	Pulley with Swivel	3004
4	Heavy Duty Pulley Assembly	2014
5	Pulley	2500
6	3/16" Cable Clamp	732
7	Screw Hook	2041
8	Extendable Drive Tube	47637
9	Pulley Assembly	28429
10	Ceiling Hook	28550
11	Handle Shank	3148
12	Drill Shaft Adapter	2886
13	Winch Handle Pin	3761
14	Winch Drive Tube (4')	2884-1
	Winch Drive Tube (8')	2884-2
	Winch Drive Tube (2')	2884-4
--	Full Line Suspension Kit	7948

Item 11 and Item 13 may be ordered as a kit under Part No. 2885.  
 Item 12 and Item 13 may be ordered as a kit under Part No. 2886  
 Item 11, 13 and 8 may be ordered as a kit under Part No. 47638.

# 14580 Electric Winch Kit

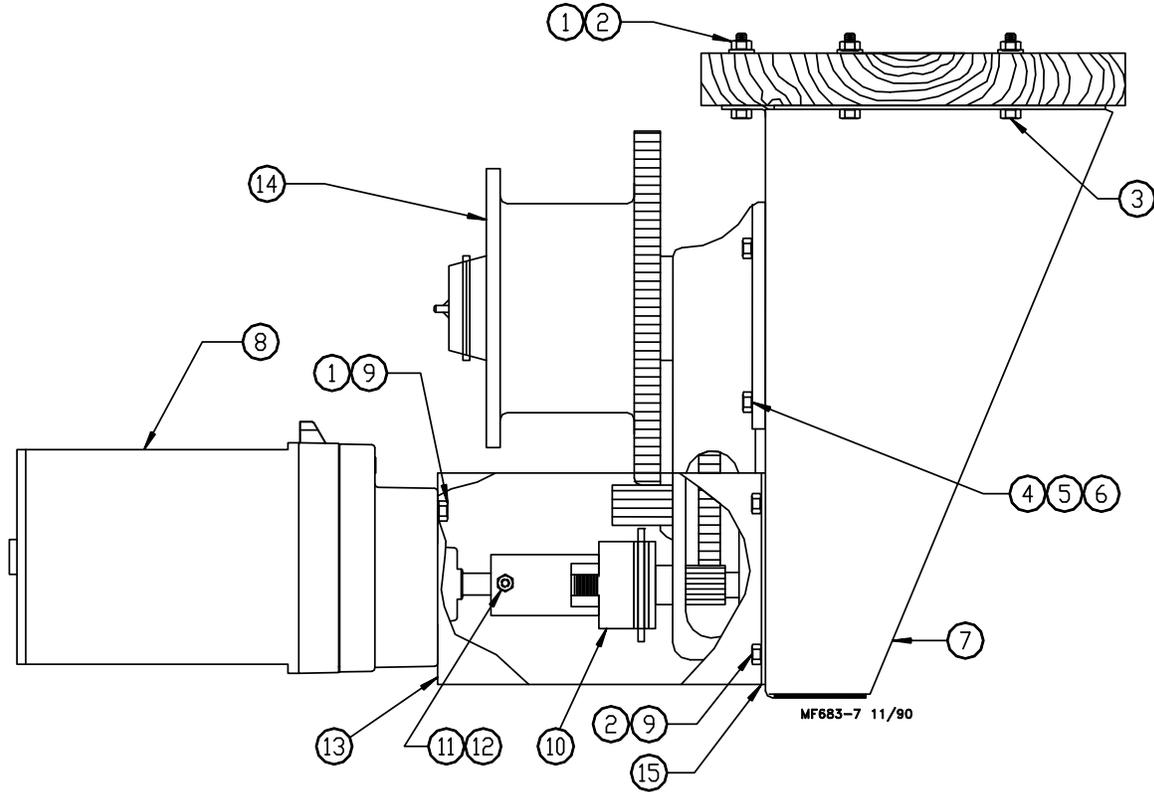

Item	Description	Part No.
1	5/16" Flat Washer	2230
2	5/16-18 Nut	2148
3	5/16-18 x 2-1/2" Hex Hd Bolt	2753
4	3/8-16 x 1" Hex Hd Bolt	2555
5	3/8" Flat Washer	4967
6	3/8" Patch Lock Nut	2183
7	Winch Mount Assembly	24580
--	Caution Decal	2527-27
--	Caution Decal	2527-29
8	Power Unit	3259-145
9	5/16-18 x 3/4" Hex Hd Bolt	2046
10	Input Shaft Assembly	27805
11	1/4-20 Socket Hd Cap Screw	5083-4
12	1/4-20 Locknut	1269
13	Power Unit Bracket	27887
14	Power Winch	2883*
15	Plastic Spacer	27833
--	Switch Box Assembly	14613

The entire assembly, except item no. 14, may be ordered under part no. 14560 Electric Winch Kit

The entire assembly, except items no. 8 and 14, may be ordered under part no. 24508 Power Lift Parts Kit.

\*See individual Parts List on page 66

### Feeder Line Components

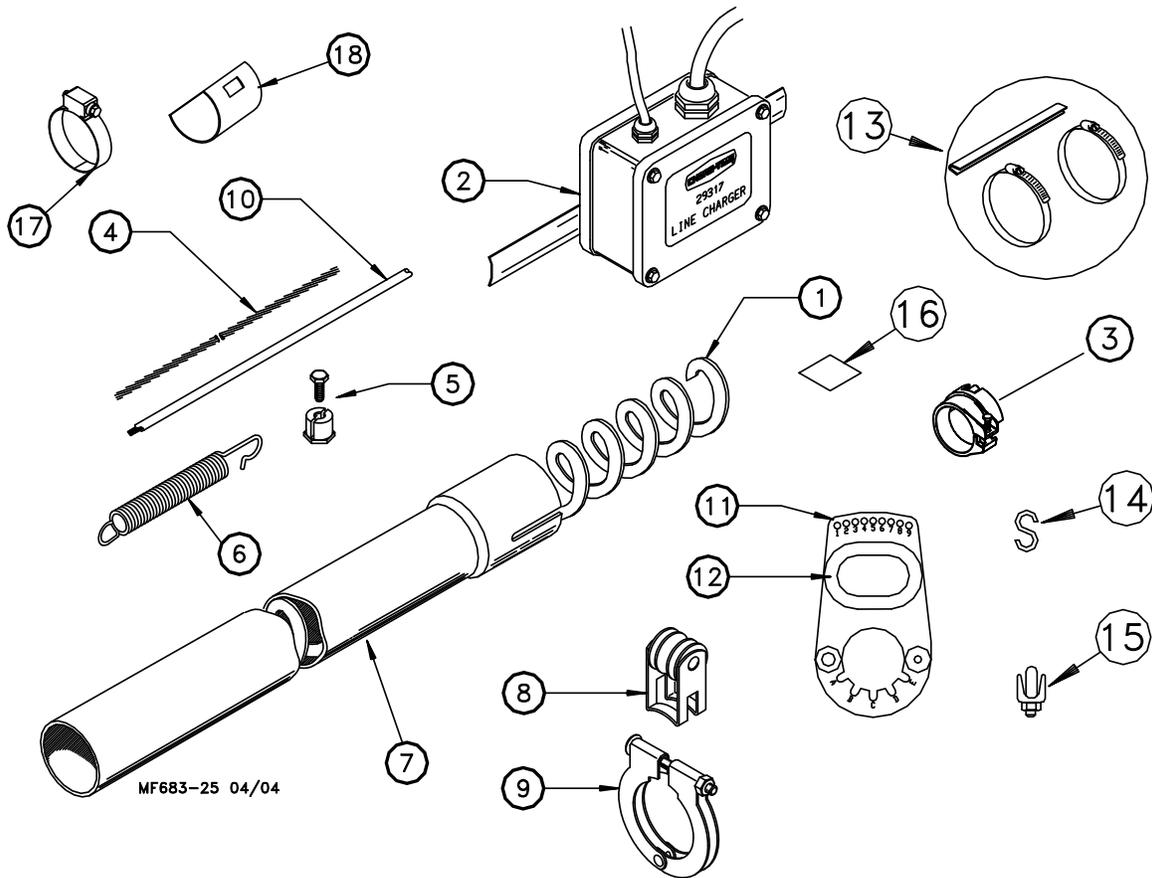

Item	Description	Part No.
1	Auger	6820wm
2	Line Charger (110v)	5458
	Line Charger (220v)	5459
3	Feeder Lock	34570
4	1/16" Cable	1922
5	1/16" Cable Clamp	1826
6	Spring	7551
7	Roll Formed Tube	
	12 Ft. 4 Hole Tube	6854-7
	9 Ft. 4 Hole Tube	6854-1
8	Anti-Roost Bracket	24060
9	Tube Clamp 1-3/4"	24063
10	Charger Wire (165')	28994-165
	Charger Wire (300')	28994-330
11	Hanger Assembly	7604
12	Grommet	14899
13	Anti-Swing Bracket	14485
14	Small "S" Hook	723
15	3/16" Cable Clamp	1213
16	Friction Pad	42443
17	Adjustment Clamp	*3527
18	Tube Closure	*9126
* These parts may be ordered as a kit under part no. 14585.		

### 47687 Power Winch

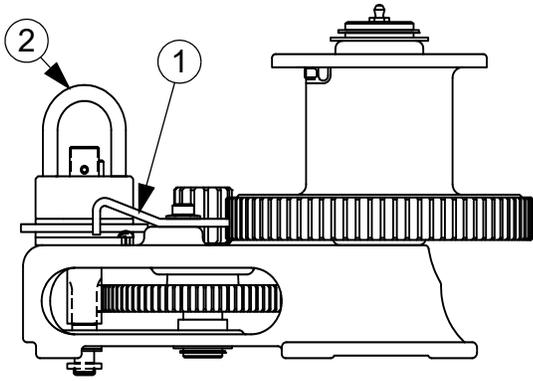

Item	Qty.	Description	Part No.
1	1	Pawl	47687-5
2	1	Input Shaft Assembly	47687-1

### Indexing Gauge

Item	Description	Part No.
1	Level Glass	4853
2	Gauge Clamp Weldment	14523
3	Pointer Assembly	4852
4	Indexing Gauge Decal	2529-207

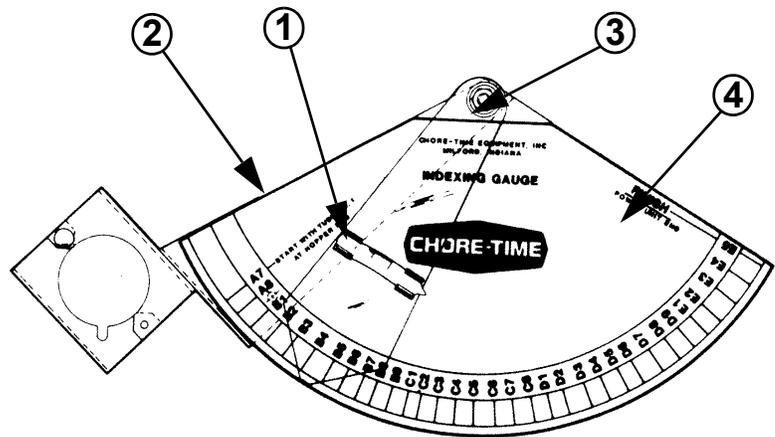

# Power Unit Assemblies

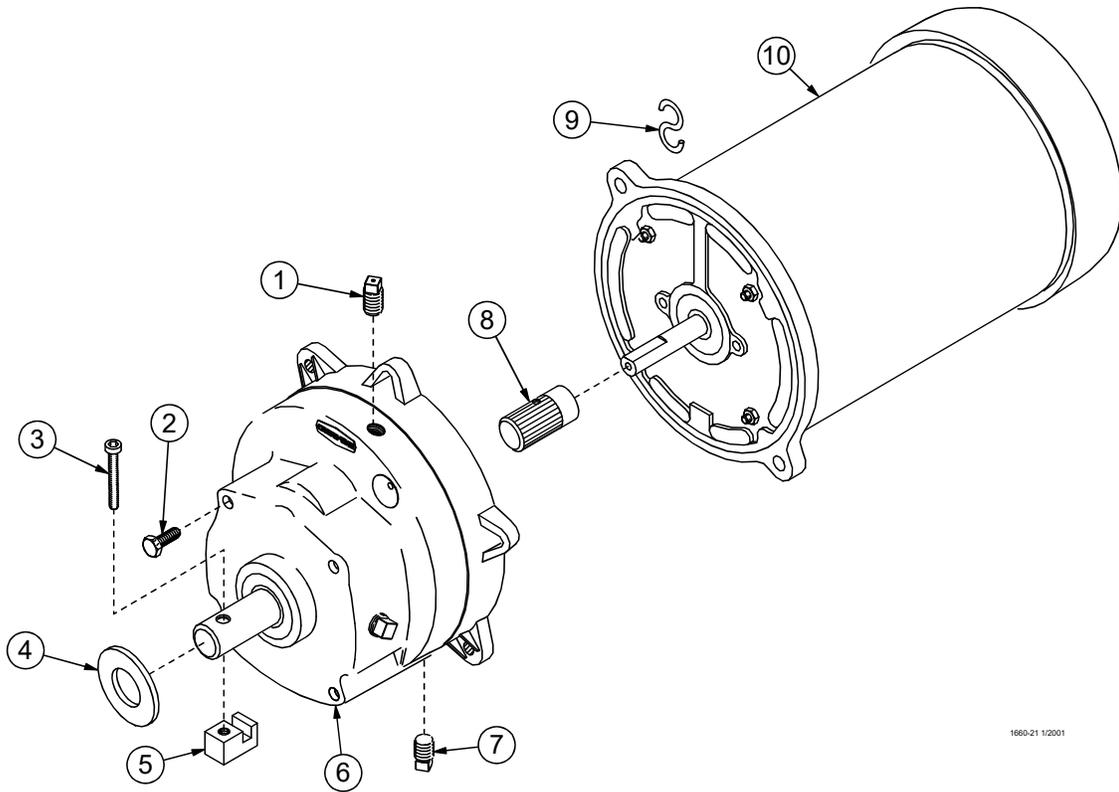

1660-21 1/2001

Item	Description	3259-81 Part No.	3259-84 Part No.	3259-100 Part No.	3259-101 Part No.	3259-144 Part No.
1	Vent Plug	3516	3516	3516	3516	3516
2	5/16-18 x 5/8 Hex Hd Screw	4412-1	4412-1	4412-1	4412-1	4412-1
3	1/4-20 x 1-1/2 Socket Hd Screw	5083-8	5083-8	5083-8	5083-8	5083-8
4	Flat Washer	1484	1484	1484	1484	1484
5	Driver Block	4642	4642	4642	4642	4642
6	Gearhead	3261-11	3261-5	3261-11	3261-11	3261-17
7	Pipe Plug (magnetic)	30160	30160	30160	30160	30160
8	Pinion Assembly	5046	5046	5046	5046	5046
9	"S" Hook	2805	2805	2805	2805	2805
10	Motor	7522	4229	28031	28032EUR	5051

Part No.	HP	RPM	Phase	Hz	Voltage	Usages
3259-81	3/4 HP	708 RPM	Single Phase	50 Hz	230	9' 4 & 12' 4 Hole Auger Tubes
3259-84	1/3 HP	348 RPM	Single Phase	60 Hz	230	9' 4 & 12' 4 Hole Auger Tubes
3259-100	1/2 HP	348 RPM	Three Phase	50 Hz	220/380	9' 1 & 9' 2 Hole Auger Tubes
3259-101	3/4 HP	696 RPM	Three Phase	50 Hz	220/380	12' 3 Hole Auger Tubes
3259-144	3/4 HP	696 RPM	Single Phase	60 Hz	230	9' 4 & 12' 4 Hole Auger Tubes



**MADE TO WORK.  
BUILT TO LAST.®**

**Revisions to this Manual**

<b>Page No.</b>	<b>Description of Change</b>	<b>ECO</b>
66	Was 2883 Winch	35577
Various	Updated Graphics	

**For additional parts and information, contact your nearest Chore-Time distributor or representative.  
Find your nearest distributor at: [www.choretime.com/contacts](http://www.choretime.com/contacts)**

CTB, Inc.  
PO Box 2000  
Milford, Indiana 46542-2000 USA  
Phone (574) 658-4101  
Email: [choretime@choretime.com](mailto:choretime@choretime.com)  
Internet: [www.choretime.com](http://www.choretime.com)