

KONAVI® Feeding System

Installation and Operators Manual

Installation and Operators Manual

Installation and Operators Manual

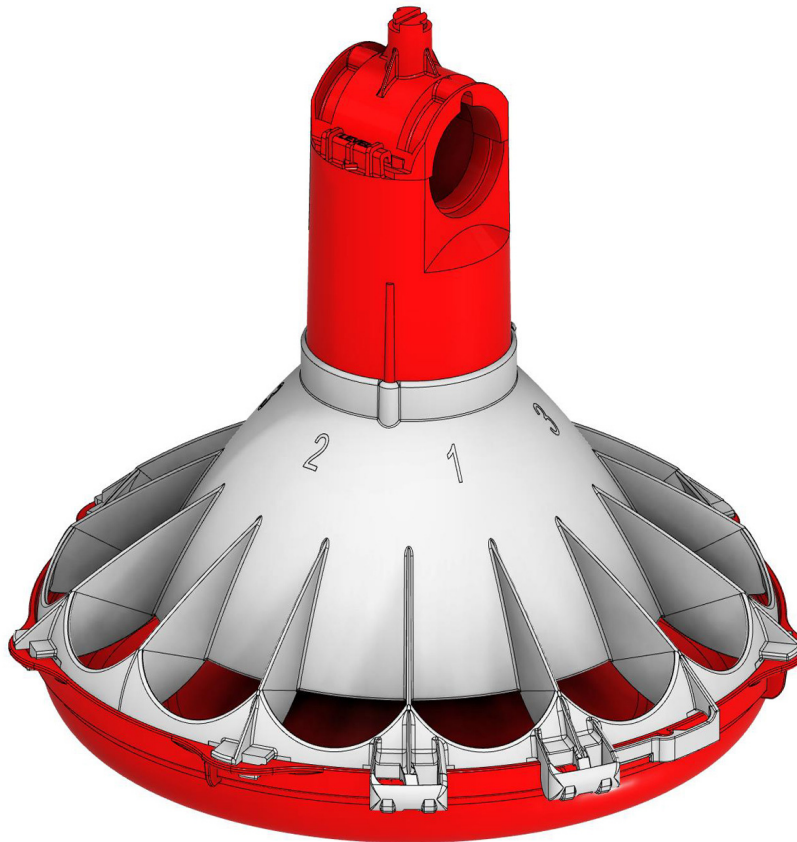

For additional parts and information, contact your nearest Chore-Time distributor or representative.
Find your nearest distributor at: www.choretime.com/contacts

Contents

Topic	Page
Chore-Time Limited Warranty	4
About This Manual	5
Safety Information	5
Safety Instructions	6
Follow Safety Instructions	6
Decal Descriptions	6
General	6
Support Information	6
General Installation Information	7
Manufacturer's Recommendations: Birds per Pan	8
Suspension System	9
Planning the Suspension System	9
Laying out the Suspension System	10
Systems over 350' [107 m]	10
Systems up to 350' [107 m]	11
Installing the Suspension System	12
Power Lift Winch Installation	12
Cable Installation	14
Hopper Suspension	18
Assembling Feeder	19
Installing Feeder on Feed Tube	20
Feeder Line Assembly and Suspension	22
Installing the End Control and Boot Assembly	24
Auger/End Control Installation	25
Auger Stretch	28
Auger Brazing	29
Mid-Line Control	30
Location/Planning	30
Installation	31
Anti-Roost Assembly	33
Wiring	35
End Control with Proximity Switch Internal Wiring	35
Proximity Sensor Wiring Diagram	35
Mid-Line Control with Proximity Sensor Internal Wiring	35
Mechanical Switch Single Phase Wiring Diagram	36
Mechanical Switch Single Phase Wiring Diagram with Motor Starter	36
Mechanical Switch Three Phase Wiring Diagram: 220 V	37
Mechanical Switch Three Phase Wiring Diagram: 380/415 V	37
Electronic Sensor Three Phase Wiring	38
Power Unit Wiring	39
3259-84 Power Unit (4229 Motor) Wiring	39
3259-85 Power Unit (5703 Motor) Wiring	39
3259-98 Power Unit (5977 Motor) Wiring	39
3259-100 Power Unit (28031 Motor) Wiring	40

Contents - continued

Topic	Page
3259-128 Power Unit (24624 Motor) Wiring	40
Troubleshooting	41
Maintenance	42
Floor Feeding System Maintenance	42
Gear Head Maintenance	42
Mechanical Switch Adjustment procedure for Control Units	43
Feeder Line	44
Power Lift Winch Maintenance	44
Management	45
Initial Start-up of the Feeding System	45
To operate	46
General Operation of the KONAVI® Feeders	46
Controlling the Feeders (optional equipment)	47
Electro-guard Operation	47
Parts List	48
150# Plastic Hopper	48
200# Hopper Components	49
100 # Hopper Components	50
Hopper Mount Bracket	51
Single Boot Components Part No. 6822	51
Twin Boot Components Part No. 6824	52
Feeder Line Components	53
KONAVI® Pan Assemblies	54
Power Unit Assemblies	56
Power Unit Assembly Part Numbers	56
KONAVI® Mechanical End Control 57697	58
KONAVI® Proximity Sensor End Control 57698	60
KONAVI® 57699 Proximity Sensor Mid Line Control	62
KONAVI® MECHANICAL MID LINE CONTROL 57700	63
Winch (Part No. 47687)	64
Miscellaneous Suspension Components	65

Chore-Time Limited Warranty

Chore-Time Group, a division of CTB, Inc. (“Chore-Time”) warrants the new CHORE-TIME KONAVI® products manufactured by Chore-Time to be free from defects in material or workmanship under normal usage and conditions, for One (1) year from the date of installation by the original purchaser (“Warranty”). Chore-Time provides for an extension of the aforementioned Warranty period (“Extended Warranty Period”) with respect to certain Product parts (“Component Part”) as set forth in the table below. If such a defect is determined by Chore-Time to exist within the applicable period, Chore-Time will, at its option, (a) repair the Product or Component Part free of charge, F.O.B. the factory of manufacture or (b) replace the Product or Component Part free of charge, F.O.B. the factory of manufacture. This Warranty is not transferable, and applies only to the original purchaser of the Product.

Component Part	Extended Warranty Period
RXL Fan (except motors and bearings)	Three (3) Years
TURBO® Fan (except motors and bearings)	Three (3) Years
TURBO® Fan fiberglass housing, polyethylene cone, and cast aluminum blade.	Lifetime of Product
TURBO® fan motor and bearings.	Two (2) Years
Chore-Time® Poultry Feeder Pan	Three (3) Years
Chore-Time® Rotating Centerless Augers (except where used in applications involving high moisture feed stuffs exceeding 17%)	Ten (10) Years
Chore-Time Steel Auger Tubes	Ten (10) Years
ULTRAFLO® Breeder Feeding System auger and feed trough.	Five (5) Years
ULTRAPAN® Feeding System augers.	Five (5) Years

CONDITIONS AND LIMITATIONS

THIS WARRANTY CONSTITUTES CHORE-TIME’S ENTIRE AND SOLE WARRANTY AND CHORE-TIME EXPRESSLY DISCLAIMS ANY AND ALL OTHER WARRANTIES, INCLUDING, BUT NOT LIMITED TO, EXPRESS AND IMPLIED WARRANTIES, INCLUDING, WITHOUT LIMITATION, WARRANTIES AS TO MERCHANTABILITY OR FITNESS FOR PARTICULAR PURPOSES. CHORE-TIME shall not be liable for any direct, indirect, incidental, consequential or special damages which any purchaser may suffer or claim to suffer as a result of any defect in the Product. Consequential or Special Damages as used herein include, but are not limited to, lost or damaged products or goods, costs of transportation, lost sales, lost orders, lost income, increased overhead, labor and incidental costs, and operational inefficiencies. *Some jurisdictions prohibit limitations on implied warranties and/or the exclusion or limitation of such damages, so these limitations and exclusions may not apply to you. This warranty gives the original purchaser specific legal rights. You may also have other rights based upon your specific jurisdiction.*

Compliance with federal, state and local rules which apply to the location, installation and use of the Product are the responsibility of the original purchaser, and CHORE-TIME shall not be liable for any damages which may result from non-compliance with such rules.

The following circumstances shall render this Warranty void:

- Modifications made to the Product not specifically delineated in the Product manual.
- Product not installed and/or operated in accordance with the instructions published by the CHORE-TIME.
- All components of the Product are not original equipment supplied by CHORE-TIME.
- Product was not purchased from and/or installed by a CHORE-TIME authorized distributor or certified representative.
- Product experienced malfunction or failure resulting from misuse, abuse, mismanagement, negligence, alteration, accident, or lack of proper maintenance, or from lightning strikes, electrical power surges or interruption of electricity.
- Product experienced corrosion, material deterioration and/or equipment malfunction caused by or consistent with the application of chemicals, minerals, sediments or other foreign elements.
- Product was used for any purpose other than for the care of poultry and livestock.

The Warranty and Extended Warranty may only be modified in writing by an officer of CHORE-TIME. CHORE-TIME shall have no obligation or responsibility for any representations or warranties made by or on behalf of any distributor, dealer, agent or certified representative.

Effective: **April, 2014**

About This Manual

The intent of this manual is to help you in two ways. One is to follow step-by-step in the order of assembly of your product. The other way is for easy reference if you have questions in a particular area.

Important: Read **ALL** instructions carefully before starting construction.

Important: Pay particular attention to all **SAFETY** information.

- *Metric measurements are shown in millimeters and in brackets, unless otherwise specified. “ ” equals inches and “ ’ ” equals feet in English measurements.*

Examples:

1" [25.4]

4' [1 219]

- Optional equipment contains necessary instructions for assembly or operation.
- Very small numbers near an illustration (*i.e.*, 1257-48) are identification of the graphic, not a part number.

Note: The original, authoritative version of this manual is the English version produced by CTB, Inc. or any of its subsidiaries or divisions, (hereafter collectively referred to as "CTB"). Subsequent changes to any manual made by any third party have not been reviewed nor authenticated by CTB. Such changes may include, but are not limited to, translation into languages other than English, and additions to or deletions from the original content. CTB disclaims responsibility for any and all damages, injuries, warranty claims and/or any other claims associated with such changes, inasmuch as such changes result in content that is different from the authoritative CTB-published English version of the manual. For current product installation and operation information, please contact the customer service and/or technical service departments of the appropriate CTB subsidiary or division. Should you observe any questionable content in any manual, please notify CTB immediately in writing to: CTB Legal Department, P.O. Box 2000, Milford, IN 46542-2000 USA.

Safety Information

Caution, Warning and Danger Decals have been placed on the equipment to warn of potentially dangerous situations. Care should be taken to keep this information intact and easy to read at all times. Replace missing or damaged safety decals immediately.

Using the equipment for purposes other than specified in this manual may cause personal injury and/or damage to the equipment.

Safety–Alert Symbol



This is a safety–alert symbol. When you see this symbol on your equipment, be alert to the potential for personal injury. This equipment is designed to be installed and operated as safely as possible...however, hazards do exist.

Understanding Signal Words

Signal words are used in conjunction with the safety–alert symbol to identify the severity of the warning.



DANGER indicates an imminently hazardous situation which, if not avoided, **WILL** result in death or serious injury.



WARNING indicates a potentially hazardous situation which, if not avoided, **COULD** result in death or serious injury.



CAUTION indicates a hazardous situation which, if not avoided, **MAY** result in minor or moderate injury.

Safety Instructions

Follow Safety Instructions

Carefully read all safety messages in this manual and on your equipment safety signs. Follow recommended precautions and safe operating practices.

Keep safety signs in good condition. Replace missing or damaged safety signs.

Decal Descriptions

DANGER: Moving Auger

This decal is placed on the Panel Weldment.

Severe personal injury will result, if the electrical power is not disconnected, prior to servicing the equipment.

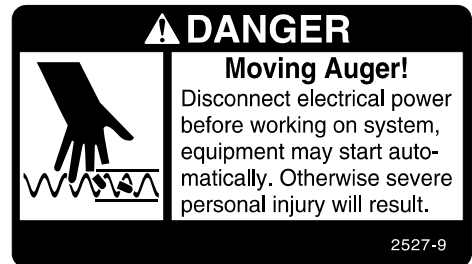

DANGER: Electrical Hazard

Disconnect electrical power before inspecting or servicing equipment unless maintenance instructions specifically state otherwise.

Ground all electrical equipment for safety.

All electrical wiring must be done by a qualified electrician in accordance with local and national electric codes.

Ground all non-current carrying metal parts to guard against electrical shock.

With the exception of motor overload protection, electrical disconnects and over current protection are not supplied with the equipment.

CAUTION:

Use caution when working with the Auger—springing Auger may cause personal injury.

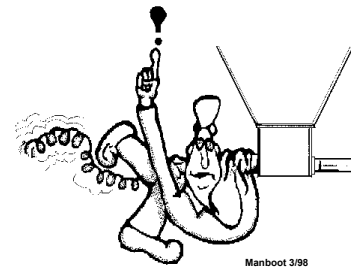
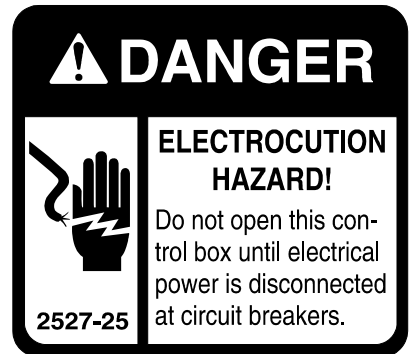

General

Support Information

The Chore-Time KONAVI® Feeding System's have been designed to feed poultry feed types. Using this equipment for any other purpose or in a way not within the operating recommendations specified in this manual will void the warranty and may cause personal injury.

This manual is designed to provide comprehensive planning and installation information. The Table of Contents provides a convenient overview of the information in this manual.

General Installation Information

Important! Please read all installation instructions in this manual prior to beginning the installation. This manual provides the necessary information on the installation, operation, and maintenance of the Chore-Time feeding equipment you have purchased.

The KONAVI® Control Units

- 348 RPM Gearhead Delivering 17 lbs [*7.7 kg*] per minute if density of 40 lbs per cubic foot [*640 kg per cubic meter*].

Power Units Available:

- 60Hz 1PH
- 50Hz 1PH
- 60Hz 3PH

Power Units Required:

- Systems up to 300' [*91 m*] Require 1/3 HP Power Units Over 300' [*91 m*] require 1/2 HP.

Manufacturer's Recommendations: Birds per Pan

Type	Max weight and/or weeks of age	Feeders	Number of birds/pan
Broiler	4.5 lbs/2 kg.	Revolution 12, Models C2 PLUS, Liberty, C2 PLUS S, C, KONAVI®, H2™, H2™ PLUS	60 - 90
Broiler	6 lbs/2.7 kg	Revolution 8 & 12, C2 PLUS, C2 PLUS S, G PLUS, G PLUS S, C, Liberty, KONAVI®, H2, H2 PLUS	55 - 80
Broiler	7 lbs/3.1 kg	KONAVI®, Revolution 8 & 12, C2 PLUS, C2 PLUS S, G PLUS, G PLUS S, C, Liberty, H2, H2 PLUS	55 - 75
Broiler	9 lbs/4.0 kg	Revolution 8, G PLUS, G PLUS S Liberty	45 – 65
Broiler Breeder Pullet – rearing	0 – 18 weeks	C2 PLUS (Breeder), C2 PLUS S (Breeder)	14 - 15
Broiler Breeder Pullet –rearing	0 – 18 weeks Hi-Yield	C2 PLUS (Breeder), C2 PLUS S (Breeder)	12-14
Broiler Breeder Male –rearing	0 -- 18 weeks	C2 PLUS (Breeder), C2 PLUS S (Breeder), G PLUS (Breeder), G PLUS S (Breeder)	11-13
Broiler Breeder Layer	17 + weeks	C2 PLUS (Breeder), C2 PLUS S (Breeder)	13 - 14
Broiler Breeder Layer	17 + weeks Hi-Yield	C2 PLUS (Breeder), C2 PLUS S (Breeder)	12 - 13
Broiler Breeder Male	17 + weeks	Revolution 8, G PLUS (Breeder), G PLUS S (Breeder)	8-10
Commercial Layer Pullet – rearing	0 – 20 weeks	Revolution 12, C2 PLUS, H2, H2 PLUS	40-60
Commercial Layer	18 + weeks	Revolution 12, C2 PLUS, C, H2, H2 PLUS	30 - 40
Turkey Poult	0 – 7 weeks	KONAVI®, Revolution 8, H2 PLUS, H2, Liberty, G PLUS, G PLUS S	60 - 65
Turkey Hens	0 – 12 weeks	Revolution 8, G PLUS, H2 PLUS, Liberty, H2	40 - 50
Turkey Female	5 + weeks	ATF, ATF PLUS	60
Turkey Male	5 + weeks	ATF, ATF PLUS	40 - 50
Ducks	0 – 3 weeks	G PLUS, G PLUS S	60 - 70
Ducks	4 – 8 weeks	G PLUS, G PLUS S	50 - 60

***Notice:** Please be advised that the maximum number of birds that may be successfully produced per feed pan may vary based upon such factors as climate, housing type or style, bird breeds, genetic factors of the birds at issue, grower management practices, etc. All other environmental and management circumstances, such as proper bird density per house, access to adequate nutrients in feed, access to adequate water supply, proper ventilation, adequate health care for the birds, and other similar factors, must meet industry standards and recommendations, if any, of applicable bird breeder companies.

*** NOTICE:** The above Manufacturer's recommendations do not constitute a product warranty and are in no way to be considered as a guarantee of performance for poultry production. In addition, the above information in no way alters or revises the terms and conditions of any applicable Chore-Time manufacturer's warranty.

Suspension System

Planning the Suspension System

Optional Mid Line Controls may be used for partial house brooding. (See Figure 1.)

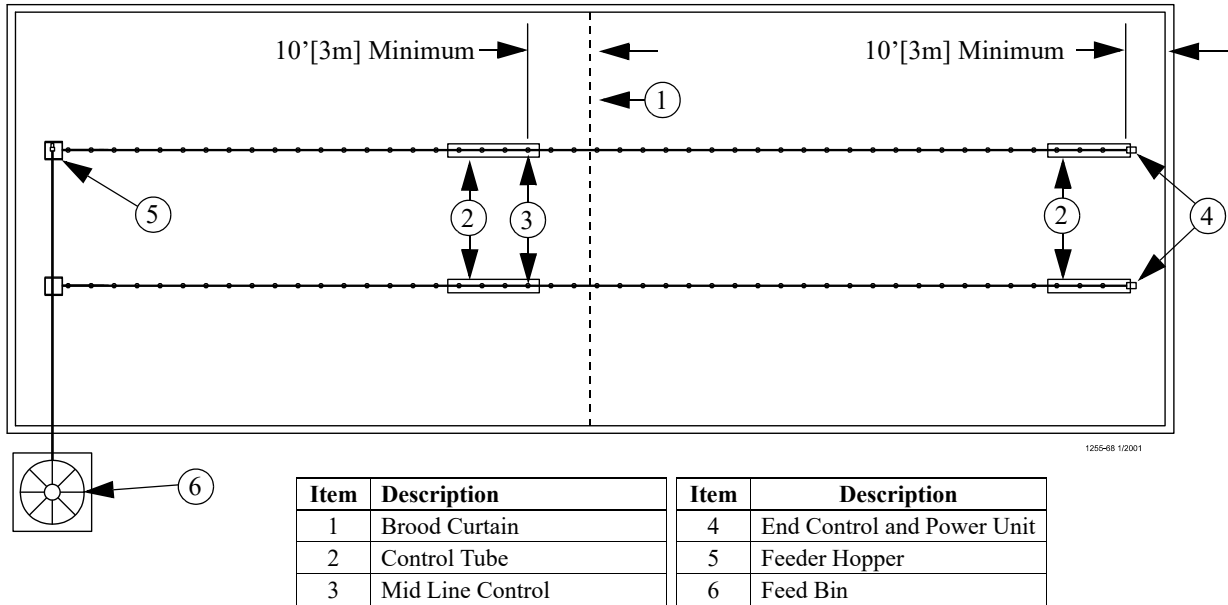

Figure 1. Component location diagram for systems up to 400 feet [122 m]. (Top View).

Systems with line lengths over 400' [122 m] should be split in the center, as shown in Figure 2. This will reduce auger running time and eliminate the need for Mid-Line Controls for partial house brooding.

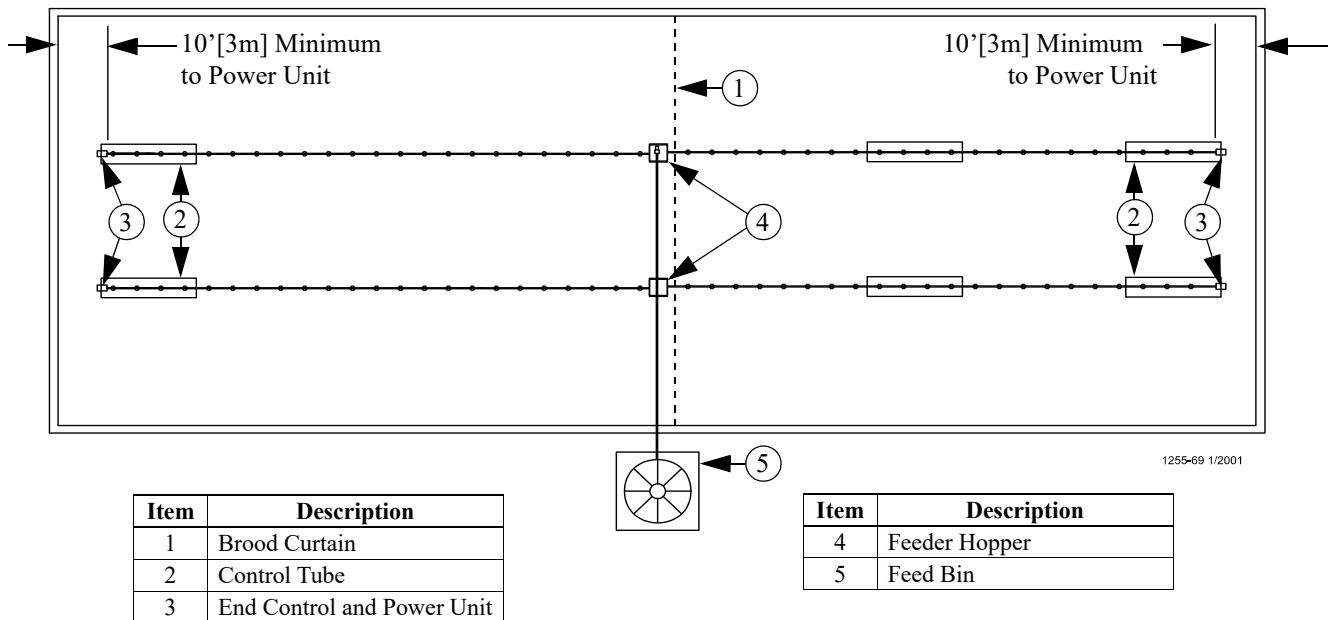

Figure 2. Component location diagram for systems over 400 feet [122 m]. (Top View).

Laying out the Suspension System

Systems over 350' [107 m]

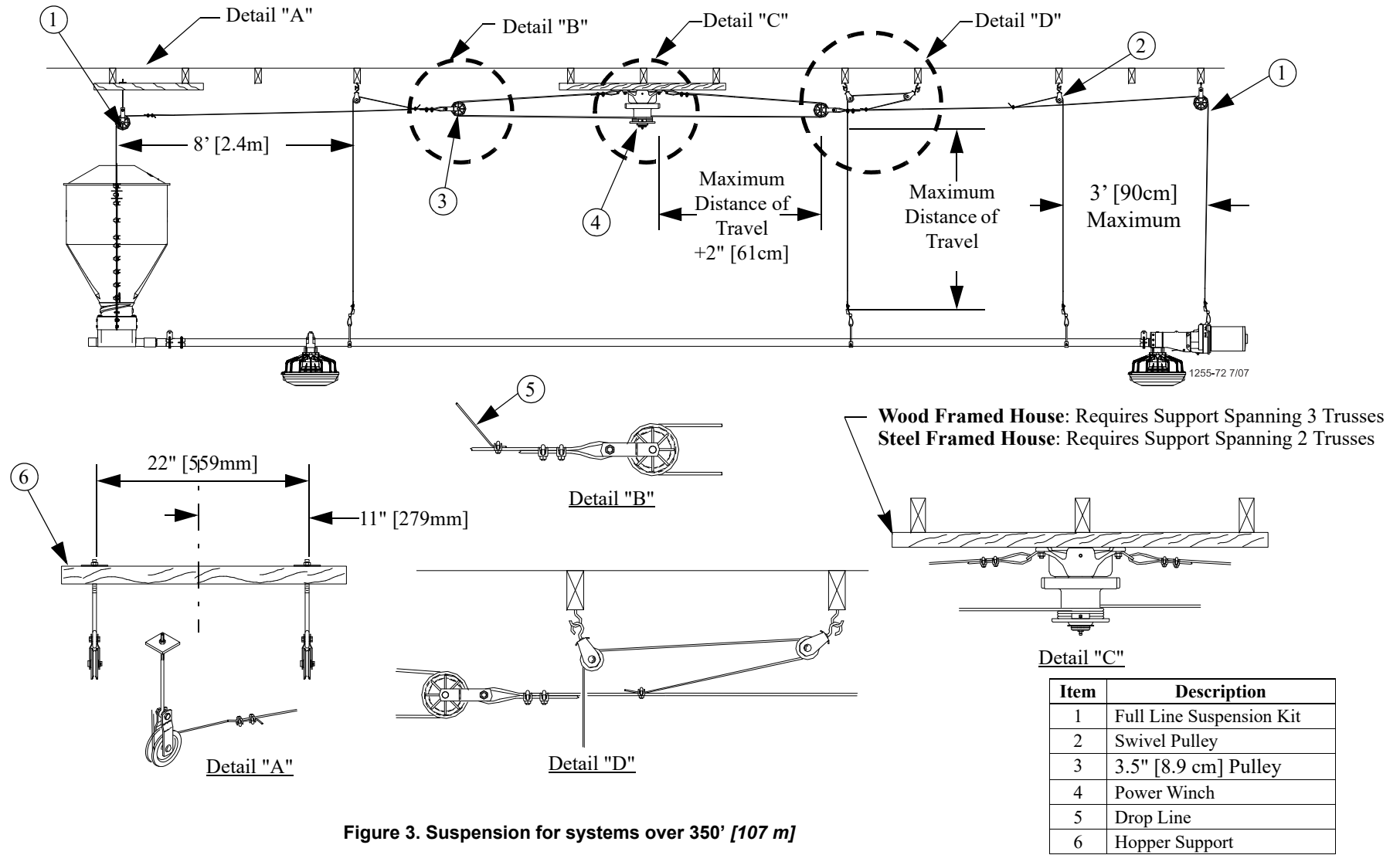
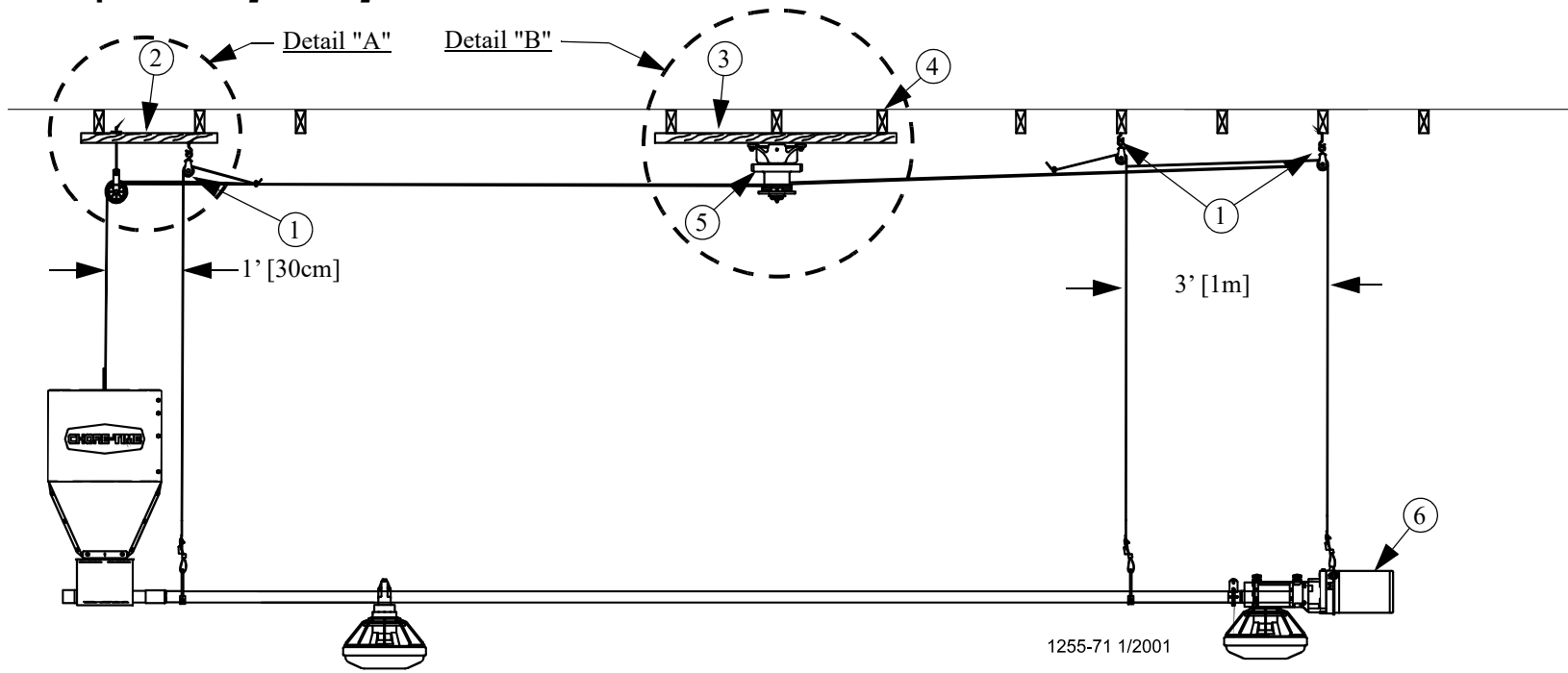
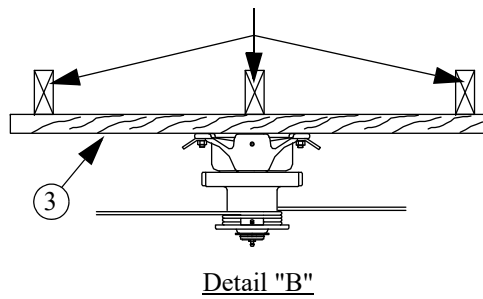
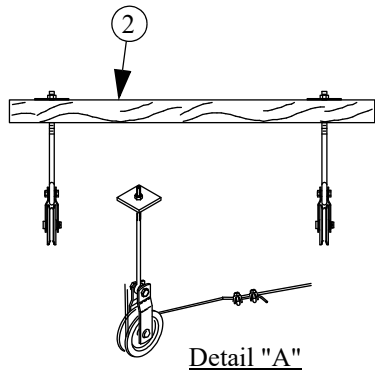

Figure 3. Suspension for systems over 350' [107 m]

Systems up to 350' [107 m]



Wood Framed House: Requires Support Spanning 3 Trusses
Steel Framed House: Requires Support Spanning 2 Trusses



Item	Description
1	Swivel Pulley
2	Hopper Support
3	Winch Support
4	Roof Truss
5	Winch
6	Power Unit

Figure 4. Suspension for systems up to 350' [107 m]

Installing the Suspension System

Power Lift Winch Installation

Power Lift Winch Support (Steel or Wood)

Wood Truss Installation

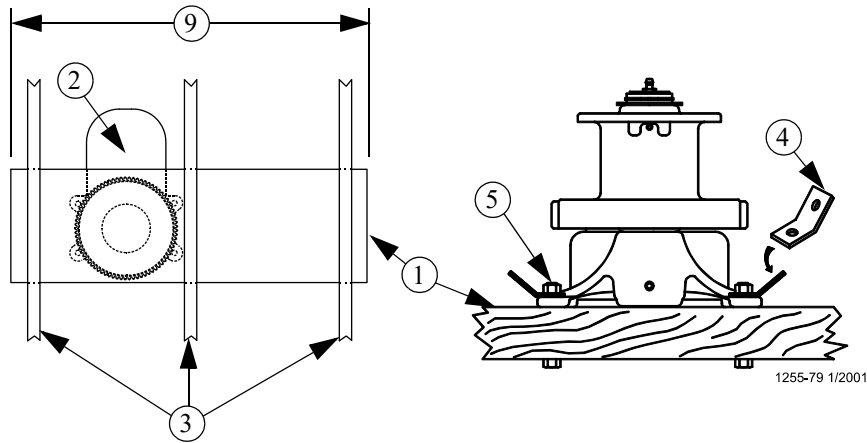

Steel Truss Installation

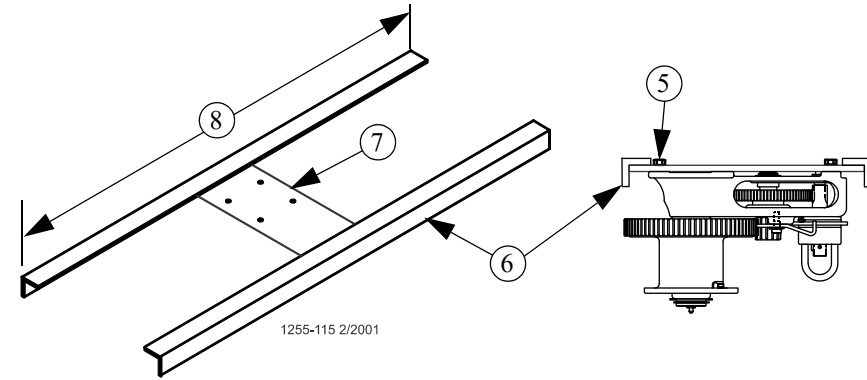

Item	Description
1	Power Lift Winch Support: 2" x 8" [50 x 200 mm] board spanning at least 3 trusses .
2	Power Lift Winch
3	Truss
4	Cable Hook: Install as shown.
5	5/16-18 Bolt, Washer, and Locknut (In parts package)
6	Angle Iron: Long enough to span 2 Trusses .
7	3/8" [9.5mm] Thick Steel Mounting Plate
8	Long enough to span 2 Trusses
9	Long enough to span 3 Trusses

Figure 5. Power Lift Winch Support

Attaching Winch Support to Trusses

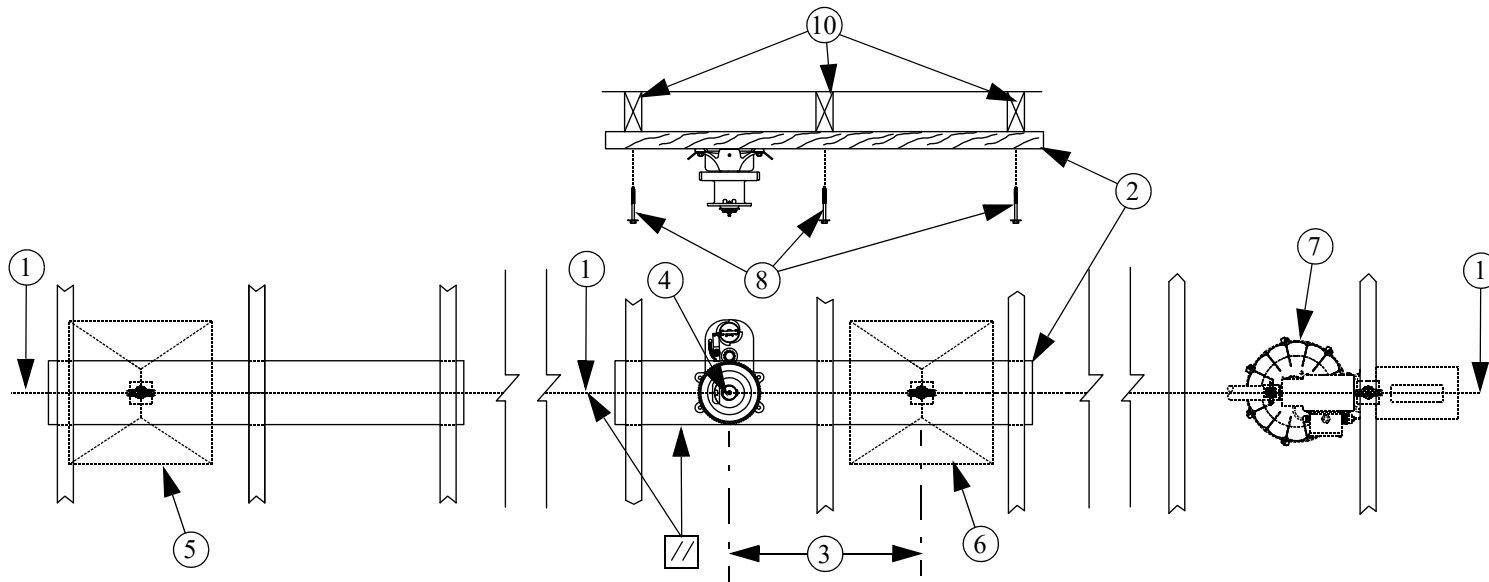

Wood Truss Installation

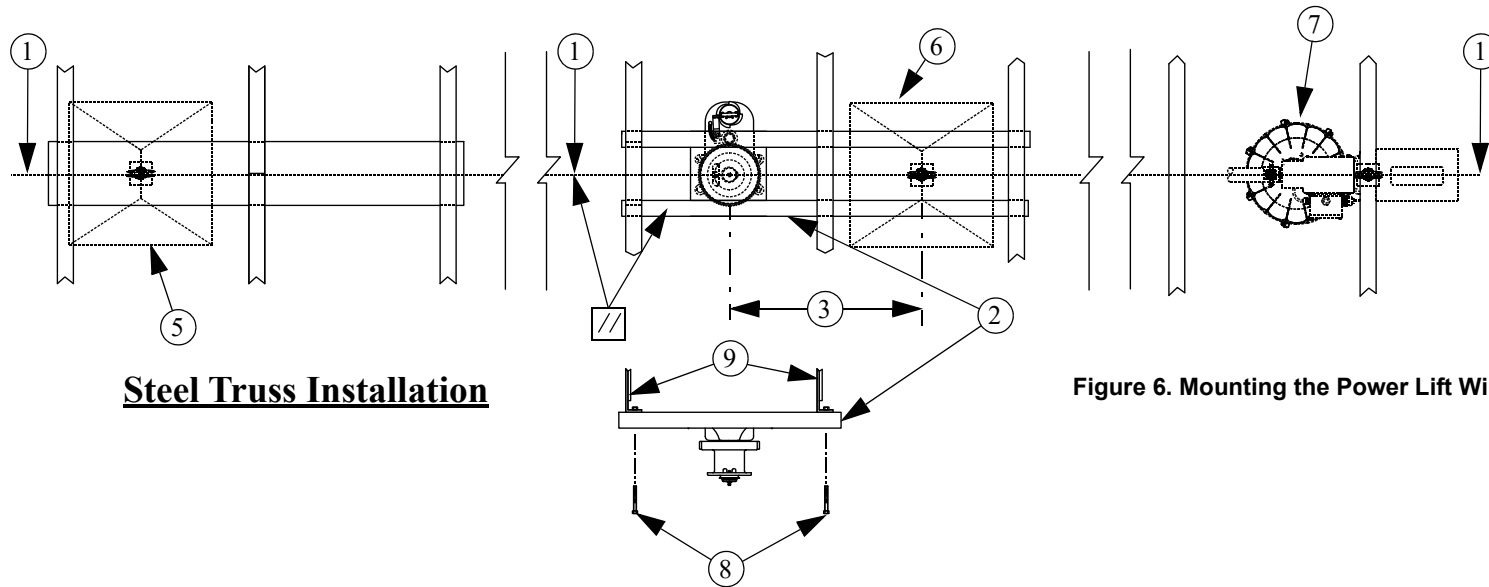

Steel Truss Installation

Item	Description
1	Feeder Line
2	Winch & Winch Support
3	Winch Centered on Feeder line unless Feed Hopper is centered.
4	Winch Centered directly over Feeder Line
5	Hopper (End of Feed line option)
6	Hopper (Center of Feed line option)
7	End Control
8	Lag Bolts
9	Steel Truss
10	Wood Truss

Figure 6. Mounting the Power Lift Winch and Support to Trusses

Cable Installation

Important! Special Support Required at Hopper Location if the Hopper is not directly under a Truss.

Special Support at Hopper Locations (Wood Construction)

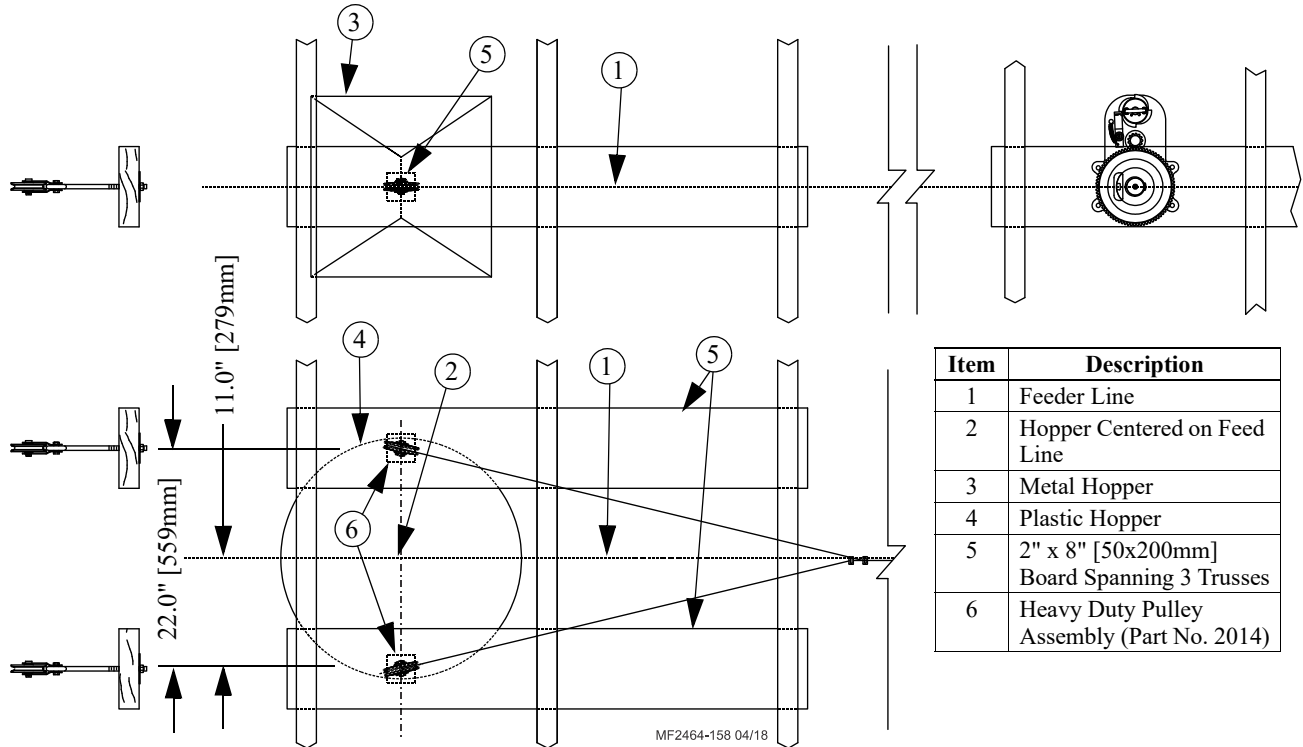

Figure 7. Cable Installations at Hopper Locations (Wood Construction)

Special Support at Hopper Location (Steel Truss)

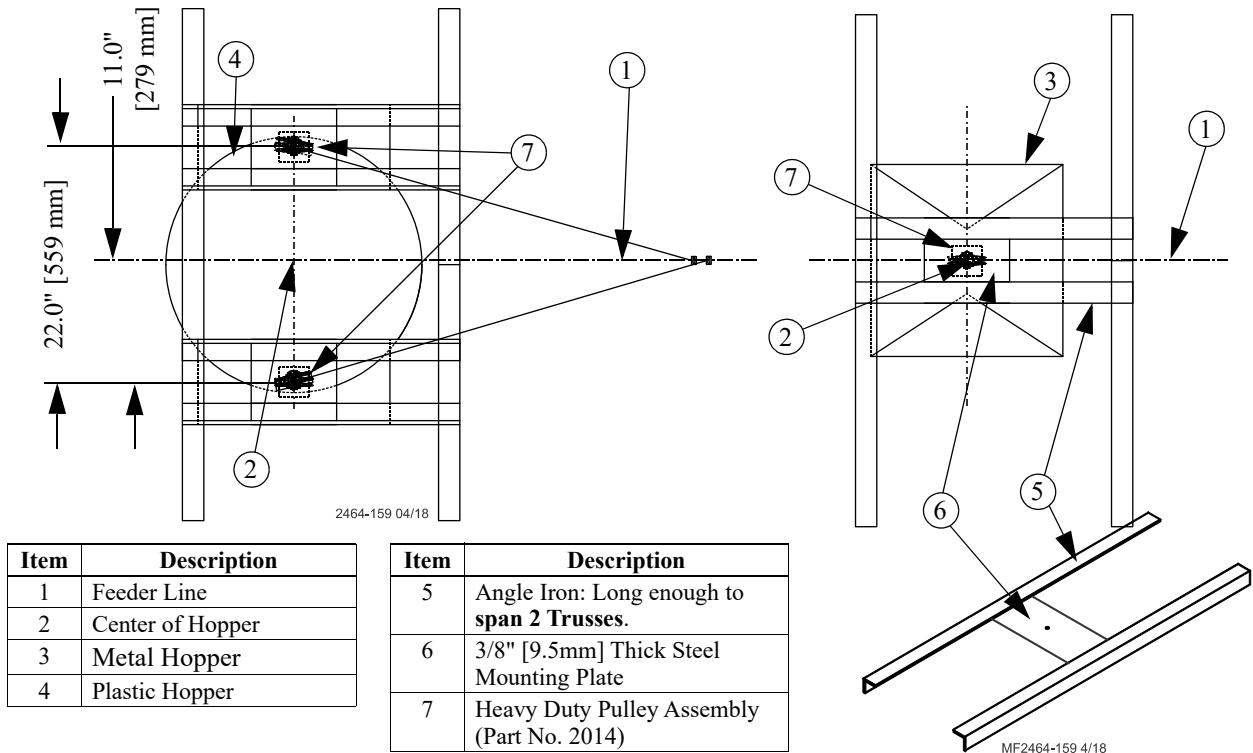
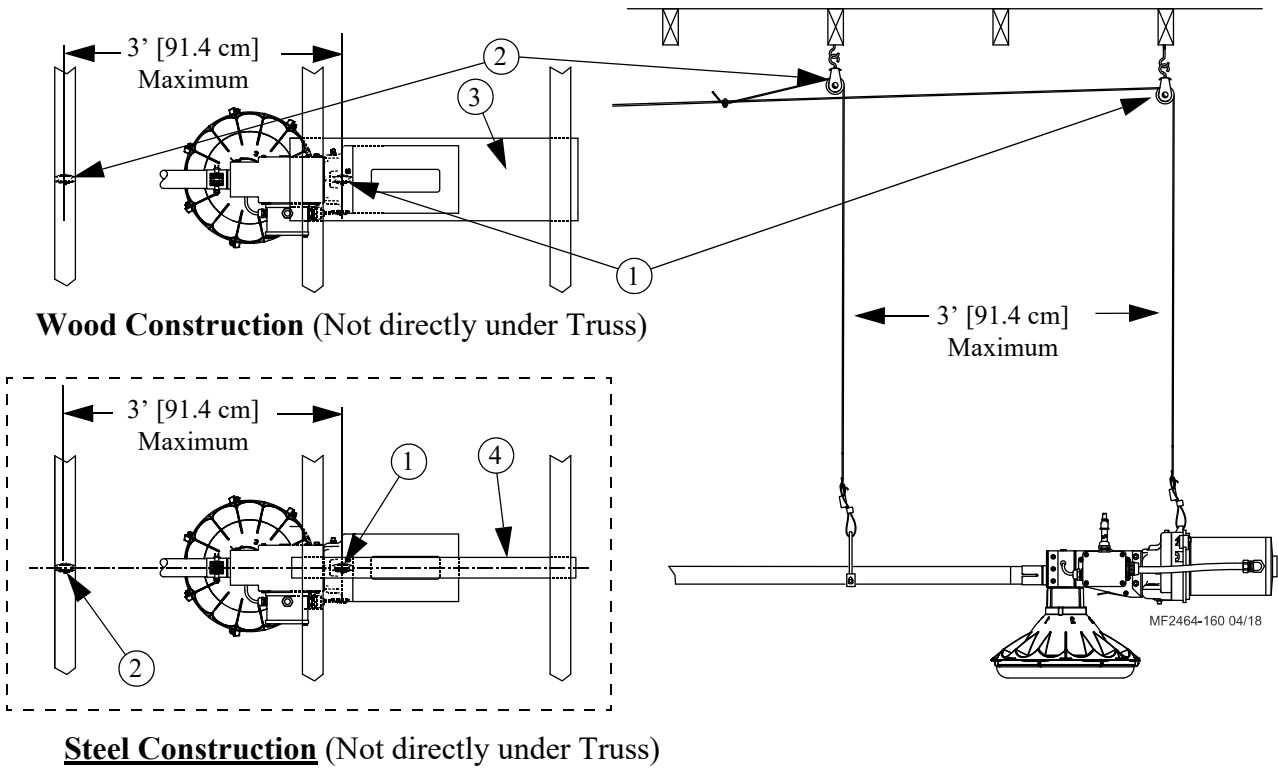

Figure 8. Special Support at Hopper Location (Steel)

Support at Power Unit Location



Item	Description
1	Power Unit Drop Pulley
2	1st Feed Line Drop Pulley
3	2" x 8" [50x200mm] Board long enough to Span 2 Trusses and support 75 lbs. [34kg]
4	Angle Iron: Long enough to span 2 Trusses and Support 75 lbs. [34kg]

Figure 9.Support at Power Unit

Attaching the Main Winch Cable (Temporarily)

Plan for a Double-Back Pulley arrangement if over 350' [107m] (See Figure 10.)

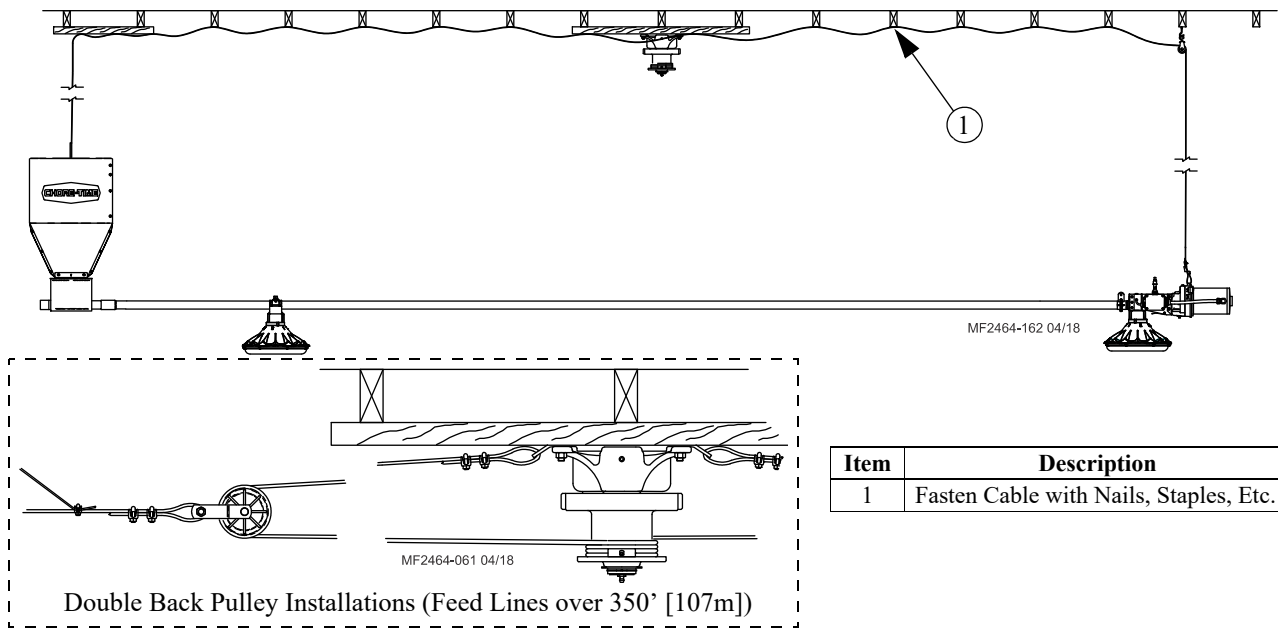

Figure 10. Temporarily Attaching Main Winch Cable to Ceiling

Cable Routing at Winch

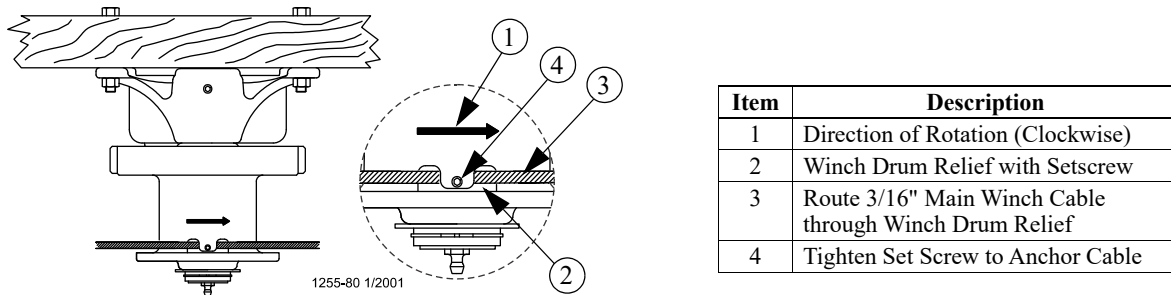

Figure 11. Winch Cable Routing

Wrapping Cable on Winch Drum

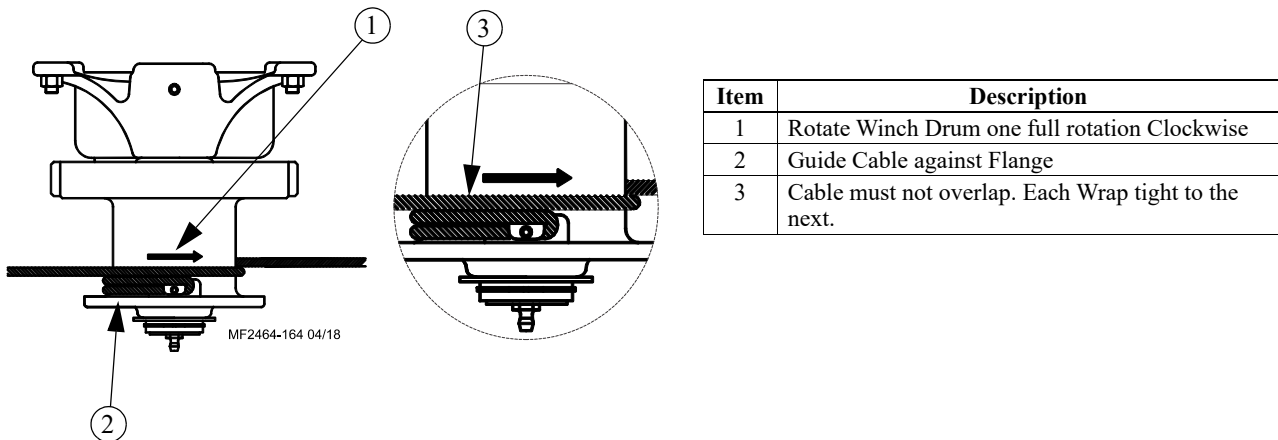
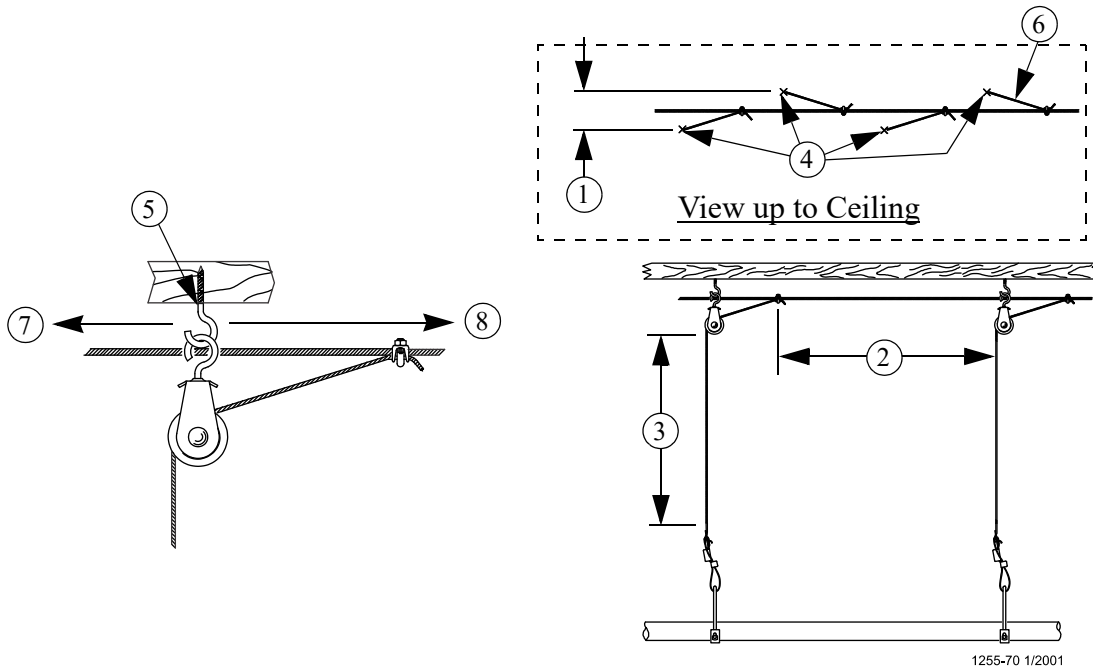

Figure 12. Wrapping Cable on Winch Drum

Screw Hook Installation

If distance raised (3) is greater than (2) then stagger Screw hooks (4) as shown.



1255-70 1/2001

Item	Description	Part No.
1	3" [7.6 cm] Offset	
2	Distance of Cable Travel (Recommended 8' [2.4m] on center). Do Not exceed 10' [3m].	
3	Distance Feeder is to be raised	
4	Screw Hook (Stagger as shown if (3) is greater than (2))	
5	Screw in Screw Hook full length of threads.	2041
6	3/32 [2mm] Drop Cable	
7	Screw Hook Opening facing opposite direction of travel.	
8	Winch End (Direction of Travel).	

Figure 13.Screw Hook Installation

Ceiling Hook Installation

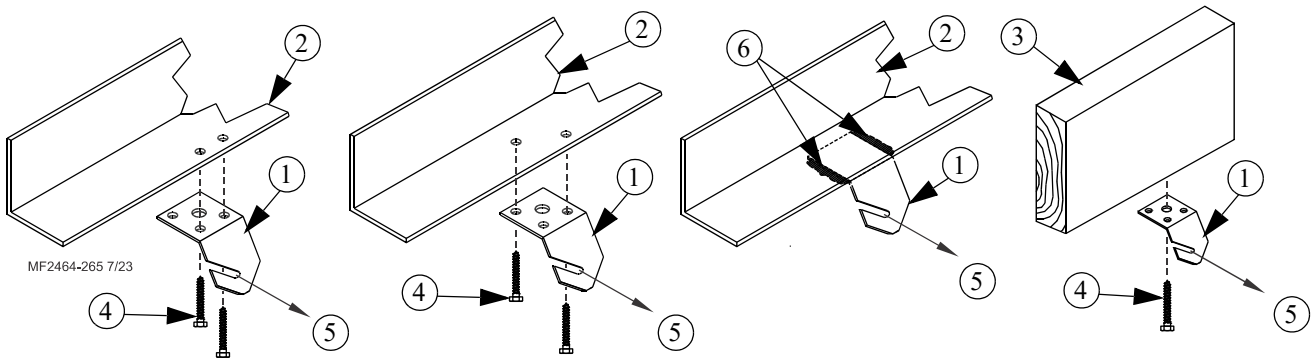

MF2464-265 7/23

Item	Description	Part No.
1	Ceiling Hook	28550
2	Steel Truss	--
3	Wood Truss	
4	1/4-20 Lag Screw	--
5	Cable Travel Direction	--
6	Weld	--

Figure 14.Ceiling Hook Installation

Drop Installation

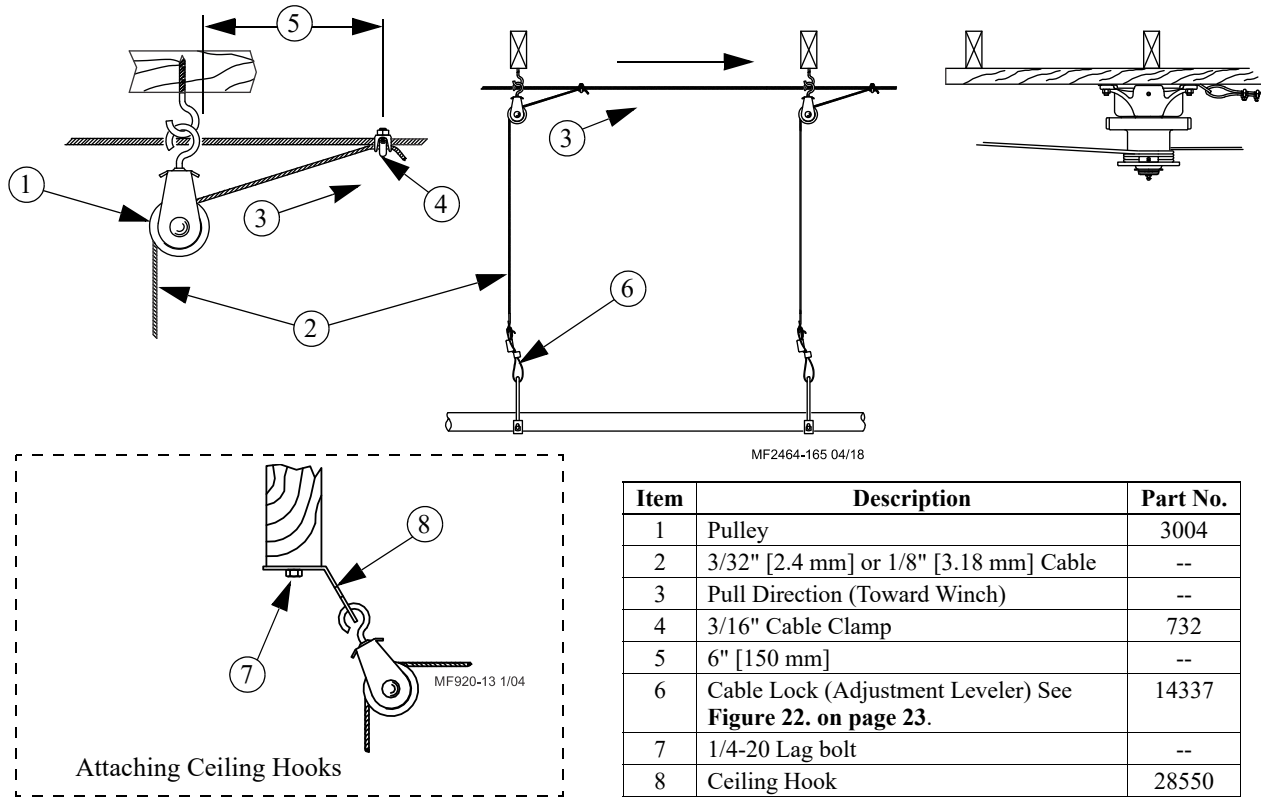

Figure 15. Standard Drop arrangement

Throwback Cable Arrangement

Cable included for Throwback pulleys beneath or near Winch (See Figure 16.)

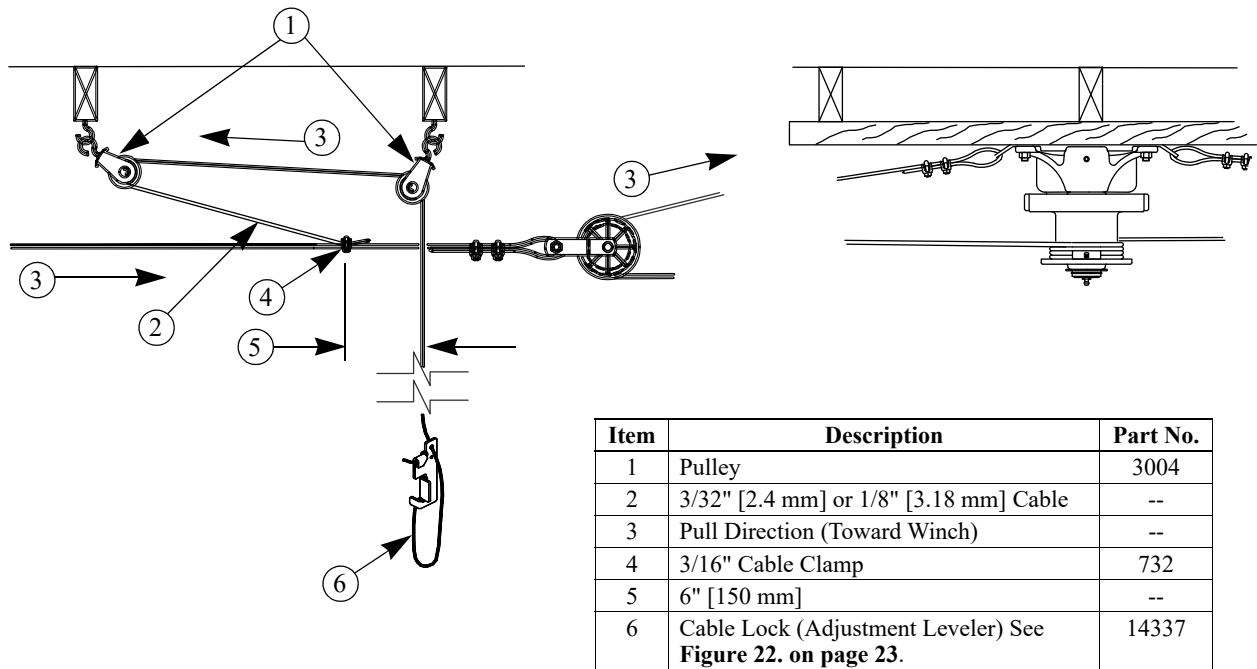

Figure 16. Drop Installation Throwback arrangement

Hopper Suspension

See Chore-Time Manual MF1819 for Hopper Assembly and installation procedure.

Assembling Feeder

1. Line up the Knobs on the Feeder Pan (**Item 1**) with the center of the Excluder (**Item 2**) Hinges and snap in place **as shown**.
2. Line up and slide the Cone Skirt (**Item 3**) over the Feed Cone (**Item 4**).
3. Line up the grooves in the Excluder with the grooves in the Feed Cone and slide them together.
4. Rotate the Excluder and insert the Tabs on the Excluder into the Slots in the Pan.

Snap the Knobs on the Pan into the Grill Hinge.

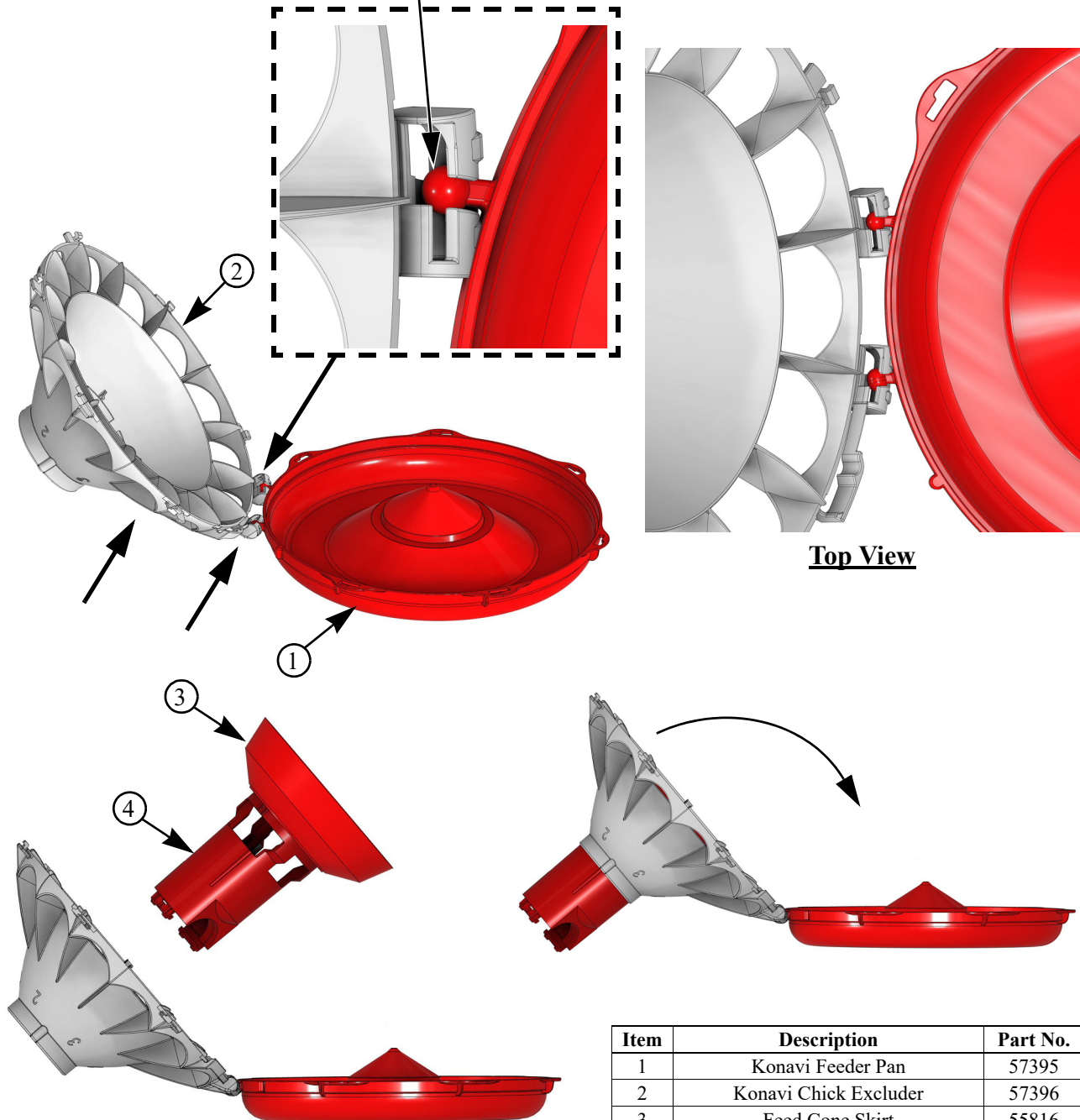

Item	Description	Part No.
1	Konavi Feeder Pan	57395
2	Konavi Chick Excluder	57396
3	Feed Cone Skirt	55816
4	Konavi Feed Cone	55822
	Konavi Feed Cone w/Slide Shut Off	55823

Figure 17. Assembling the Excluder, Pan, Cone, and Skirt

5. With all Excluder Tabs fully inserted into the slots in the Feeder Pan, rotate the Excluder Counter-Clockwise until the Excluder Snap Lock (**Item 1**) is locked in place.

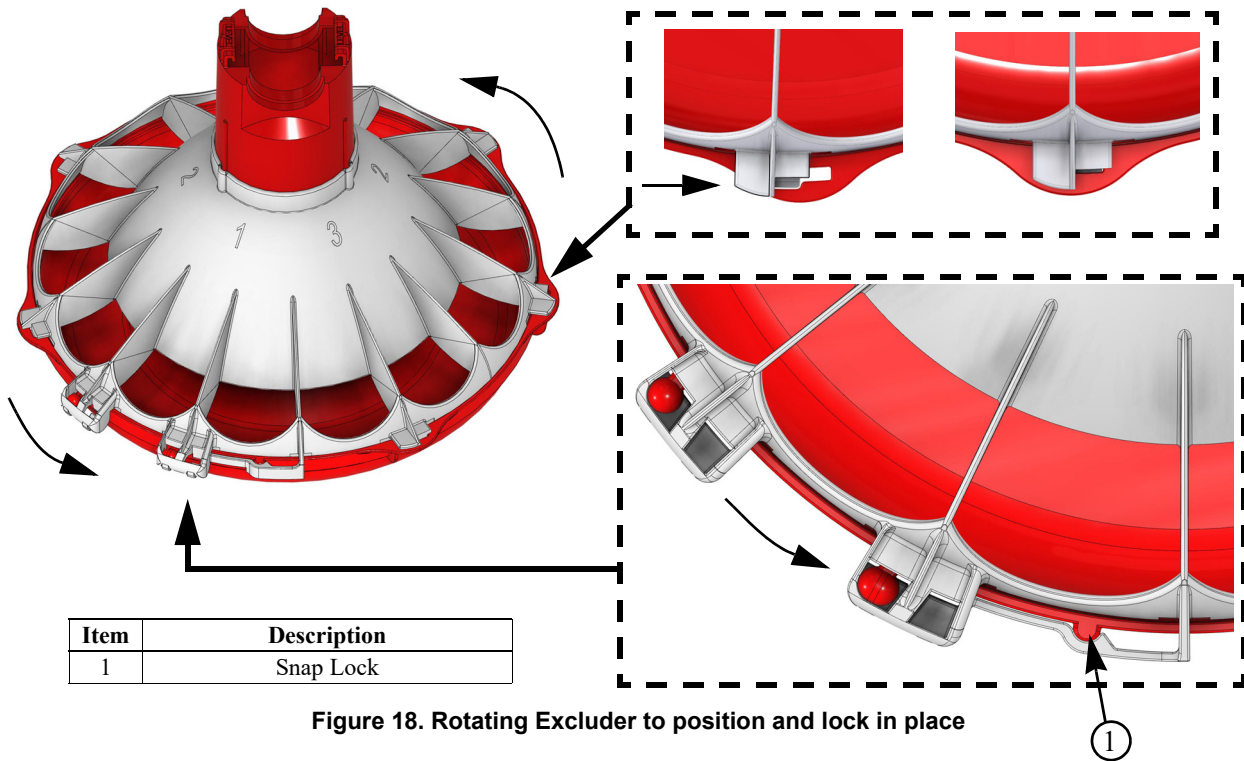

Item	Description
1	Snap Lock

Figure 18. Rotating Excluder to position and lock in place

Installing Feeder on Feed Tube

Feeders With Slide Shutoff

1. Locate the hole in the Auger Tube and position a Slide Shutoff (**Item 1**) as shown with the Crimp in the Feed Tube engaged in the Slot of the Slide Shutoff.
2. Hold the Slide Shutoff in place and lift the assembled Feeder into place as shown.
3. Install a Feed Cone Cap as shown in **Figure 20. on page 21.**

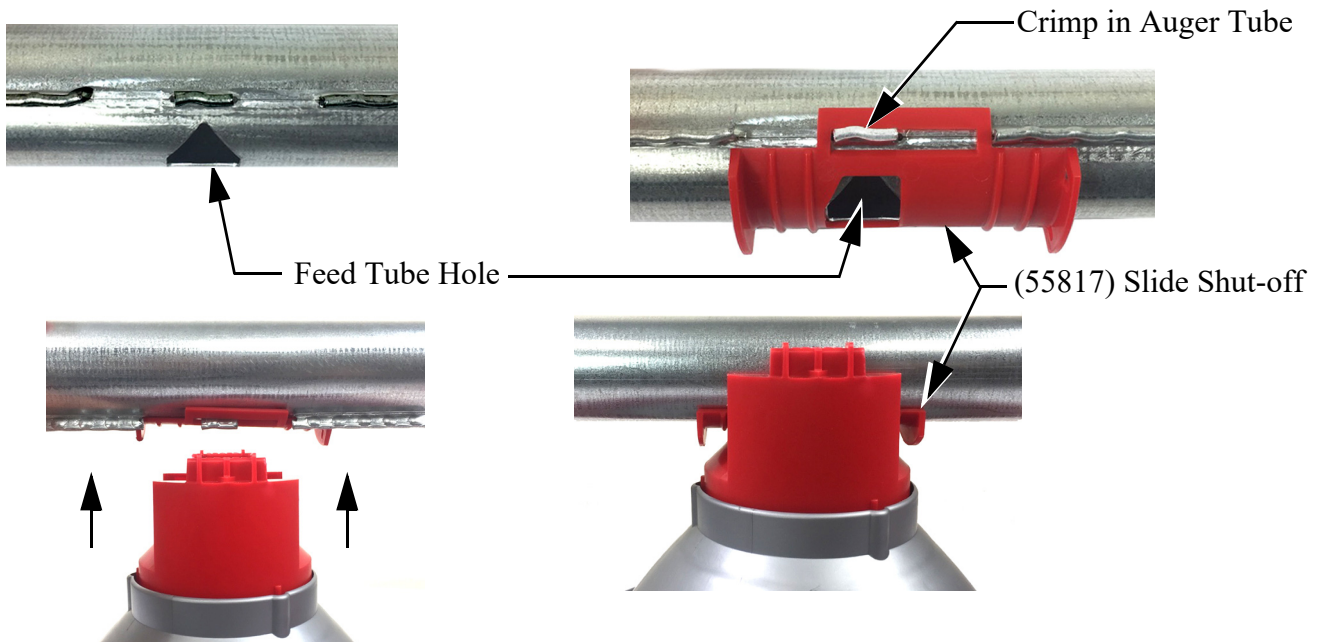

Item	Description	Part No.
1	Slide Shutoff	55817

Figure 19. Feeders with Slide Shut-off

Installing Cone Cap (All Feeders)

1. Line up the Feeder with the hole in the Feeder Tube.
2. Set a Cone Cap (**Item 1**) on the Auger Tube, and with the Tabs of the Cone Cap captured by the Cone, Slide it past the Locking Tabs (**Item 2**) locking it into place as shown.

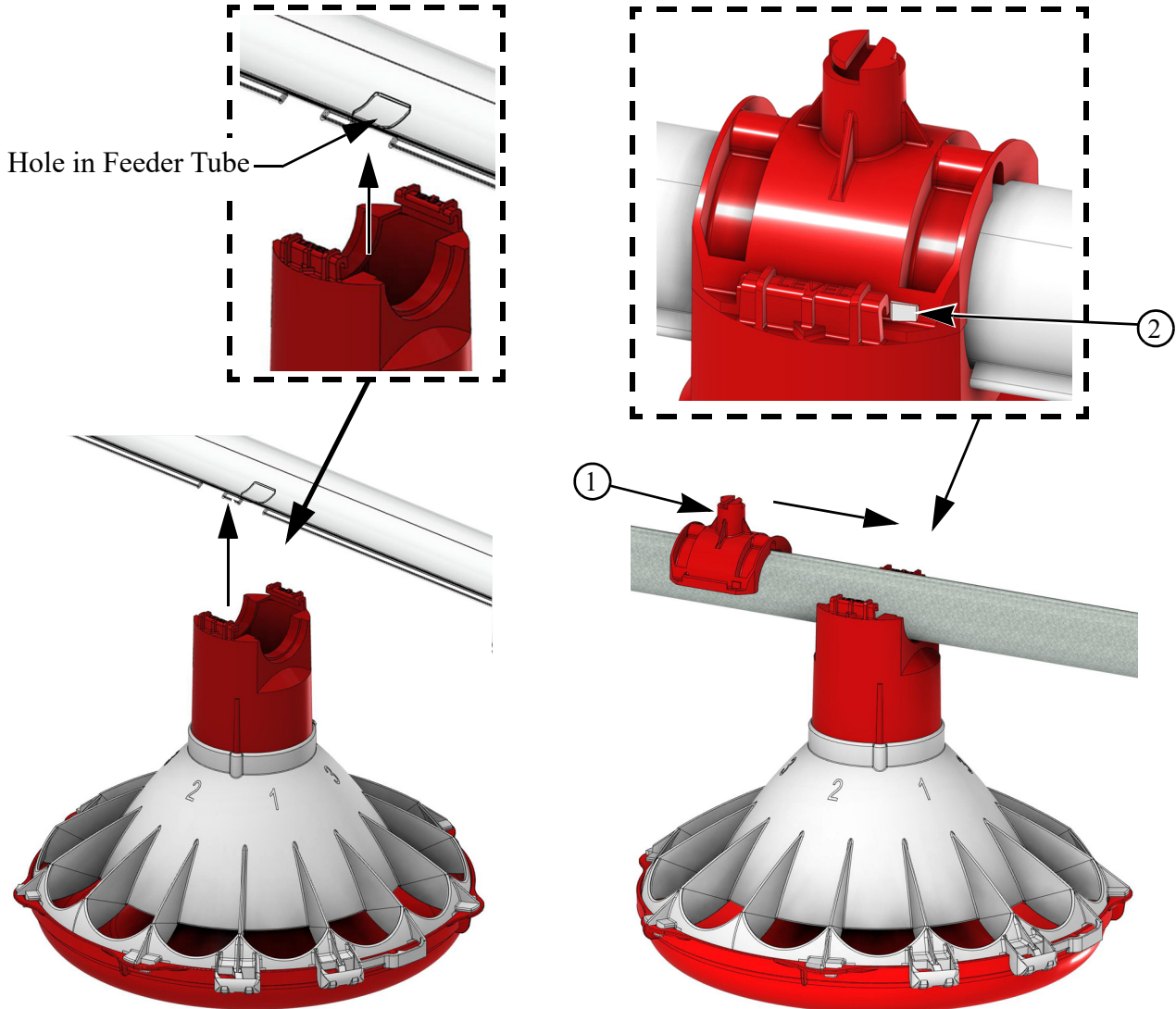

Item	Description	Part Number
1	Cone Cap	55820
2	Locking Tab	--

Figure 20. Installing the Cap

Feeder Line Assembly and Suspension

Assembling the Feeder Tubes

1. The Feeder Tubes and Feeders may be laid out end to end in approximately the final location of the line. **The belled end of each Tube should be toward the Hopper end as shown.**
2. Connect the individual feeder tubes together by inserting the straight end of one tube as far as possible into the belled end of the next tube. **The last Feeder Tube before the End Control Pan (Item 2) or Mid Line Control pan (Item 1) needs to be a Control Tube.**
3. Install a Tube Clamp Assembly (Item 5) or Clamp and Anti-Roost Bracket (Item 8) at each joint as shown.
4. Systems require an Anti-Roost Bracket at every **fifth** joint.
5. Continue down the feeder line until each tube joint has a standard Tube Clamp or Clamp/Anti-Roost Bracket. **Do not tighten at this time.**

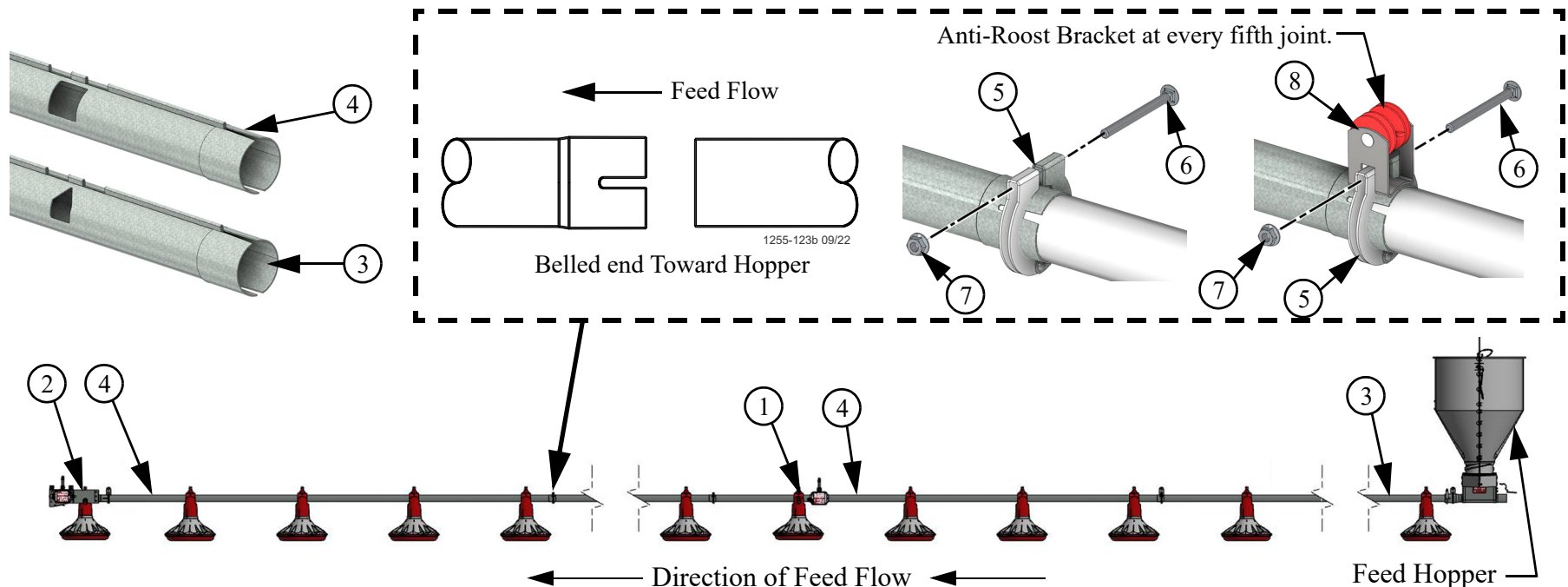

Item	Description	Part No.
1	KONAVI® Proximity Sensor Mid Line Control	57699
2	KONAVI® Proximity Sensor End Control	57698
3	Feeder Tube	Varies
4	Control Feeder Tube	Varies

Item	Description	Part No.
5*	Tube Clamp Assembly	24062
6*	1/4-20 x 2.5 Carriage Bolt	7550-3
7*	1/4-20 Flange Nut	46460
8	Anti-Roost Bracket	24060

*Included in 24063-X Tube Clamp Kit

Figure 21. Hanger Installation

Suspending the Feeder Line (Adjustment Leveler) Installation

1. Install Wire Hangers (Item 1) using Hanger Straps (Item 2) on the Feed Line Tubes at the 8' [2.4 m] spacings determined by the suspension drop lines as shown in Figure 22.
2. Install Adjustment Levelers at each Wire Hanger. See Figure for proper cable routing around the Adjustment Leveler. The maximum distance from the Wire Hanger to the Adjustment Leveler is 6" [152mm].
3. Lift the Feeder line to a comfortable working height.
4. Tighten down all of the Tube connectors at this time. **Do not** crush the tubes by over-tightening the clamps.

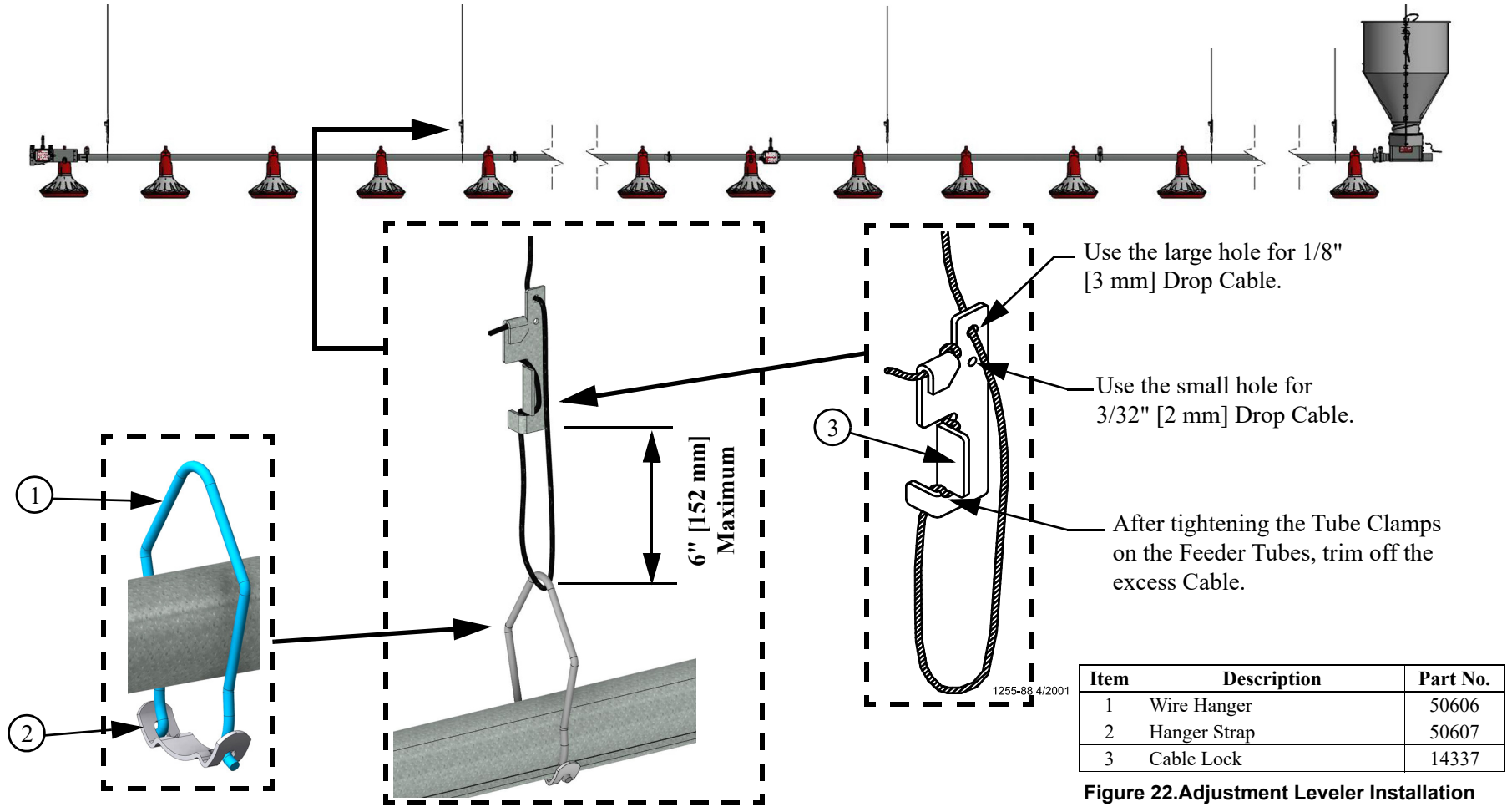

Item	Description	Part No.
1	Wire Hanger	50606
2	Hanger Strap	50607
3	Cable Lock	14337

Figure 22. Adjustment Leveler Installation

Installing the End Control and Boot Assembly

The End Control Unit must be at least 10 feet [3 m] from the end of the building to allow birds access around the end of the feeder line.

1. Assemble the End Control Unit to the Feeder Line Control Tube using a clamp/anti-roost bracket. See **Figure 23. DO NOT INSTALL THE POWER UNIT AT THIS TIME.**

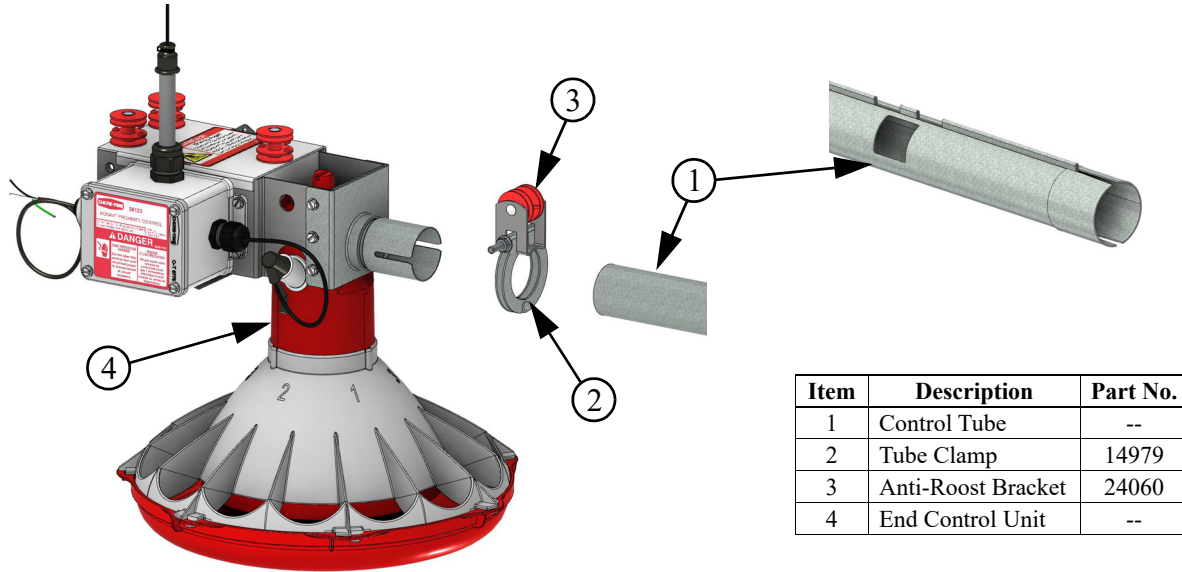

Figure 23. Connecting End Control Unit to the Feed Line Tube

2. Install the Feeder Boot (**Item 1**) by sliding the straight end of the Feeder Boot into the belled end of the Feeder Tube. Install a Clamp Assembly (**Item 2**) and Anti-roost Bracket (**Item 3**) on the bell and tighten.

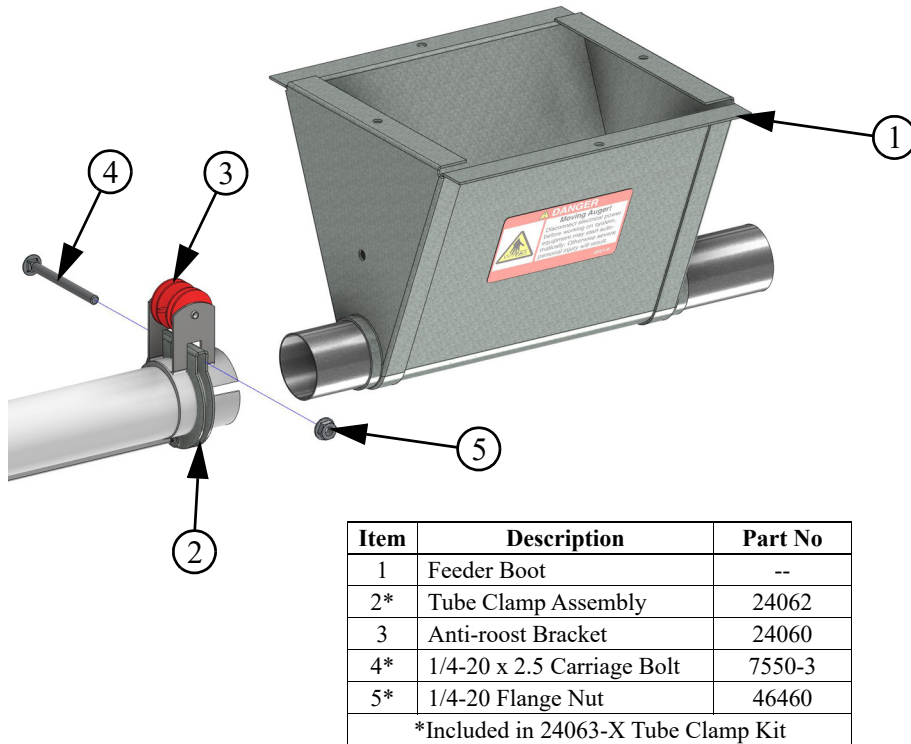
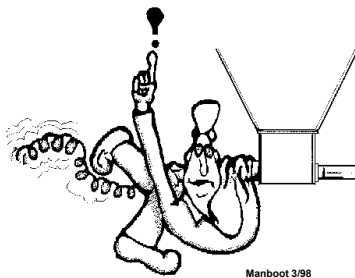

Figure 24. Installing the Feeder Boot

Auger/End Control Installation

Note: Use extreme caution when working with the auger. The auger is under tension and may spring causing personal injury. Wear protective clothing, gloves, and safety glasses when working with the auger.



BE CAREFUL WHEN WORKING WITH THE AUGER!

To avoid kinking the auger, be careful not to drop the rolled auger when handling. Inspect the auger carefully as it is installed. Small kinks may be straightened. Large kinks must be removed and the auger brazed back together.

Cut the leading 18" [450 mm] and last 18" [450 mm] off each roll of auger. Also, cut out any other distorted auger sections and reconnect the auger as specified in the Auger Brazing section of this manual.

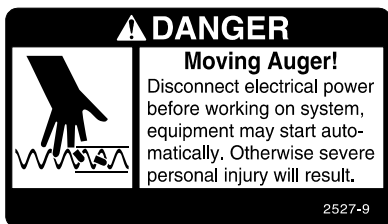

1. Use extreme caution when pushing the auger into the Auger Tubes. Keep your hand away from the end of the auger tube to avoid injury.
 With the auger coiled about 6 feet [1.8 m] from the end of the boot, uncoil the auger from the outside and feed the auger through the boot into the tubes.
 Push the auger into the tube in short strokes.
 Uncoil and handle the auger carefully to avoid damaging or kinking the auger.
2. If more than one coil is required for each feeder line, the auger ends will have to be brazed together. Refer to the Brazing the Auger section in this manual.
3. Install the Anchor Plate to the Power Unit/Gearhead, as shown in **Figure 25**.

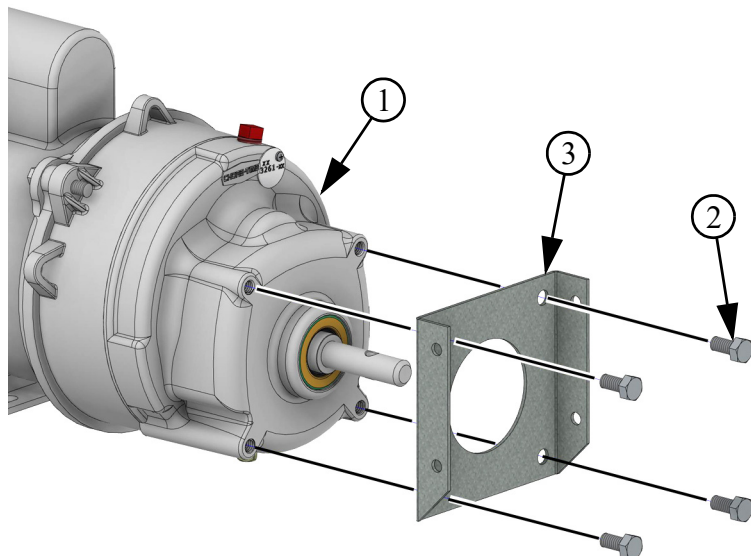

Item	Description	Part No.
1	Power Unit	--
2	5/16-18 x .63 Bolt	4412-1
3	Anchor Plate	4188

Figure 25. Assemble the Anchor Plate to the Power Unit/Gearhead

4. Slide the Drive Tube and flat washer over the output shaft on the Power Unit, as shown in **Figure 26**.
5. Continue installing auger until the auger reaches the Control Unit end of the feeder line.
6. Turn the Drive Tube Weldment into the auger, then attach to the output shaft of the Power Unit, as shown in **Figure 26**. Use the Driver Block to secure the auger to the Output Shaft.

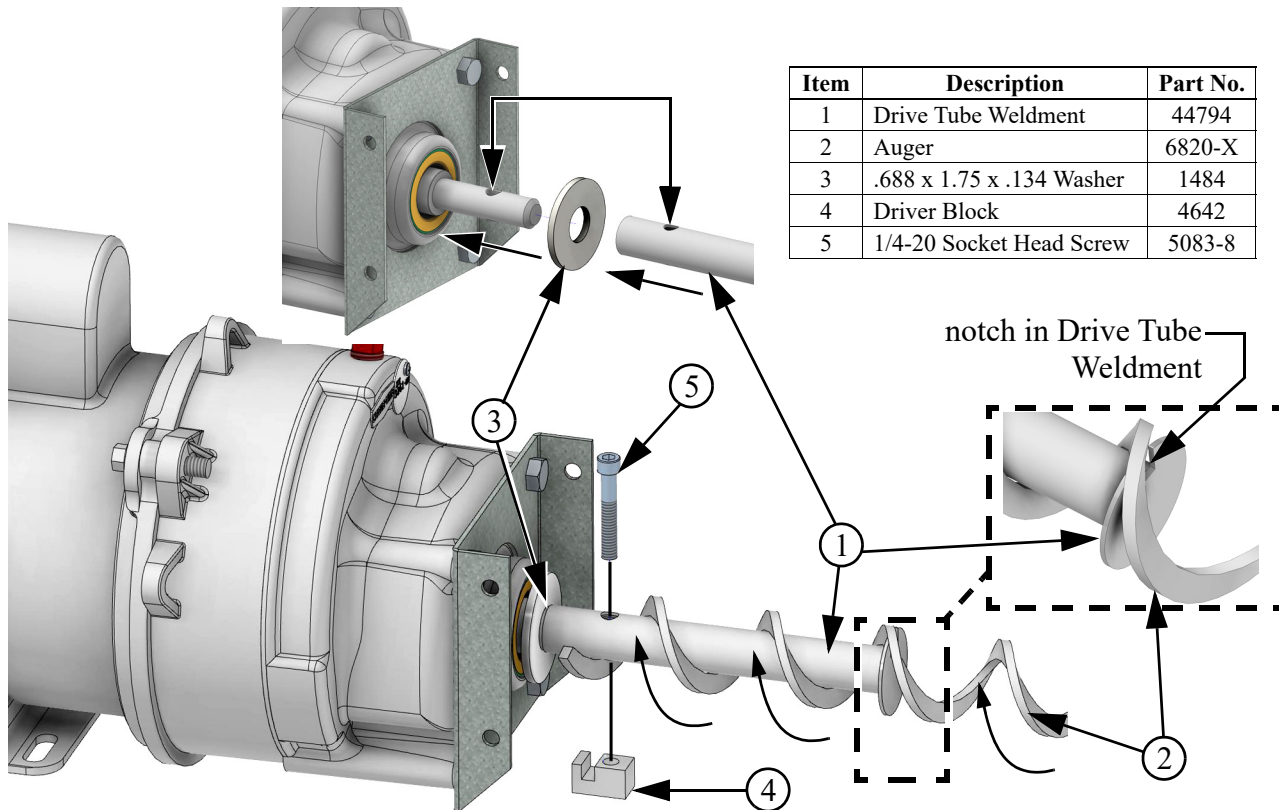

Item	Description	Part No.
1	Drive Tube Weldment	44794
2	Auger	6820-X
3	.688 x 1.75 x .134 Washer	1484
4	Driver Block	4642
5	1/4-20 Socket Head Screw	5083-8

Figure 26. Auger Driver Components

7. Attach the Anchor Plate and Gearhead Assembly to the Control Unit Body using the included hardware shown in **Figure 27**.

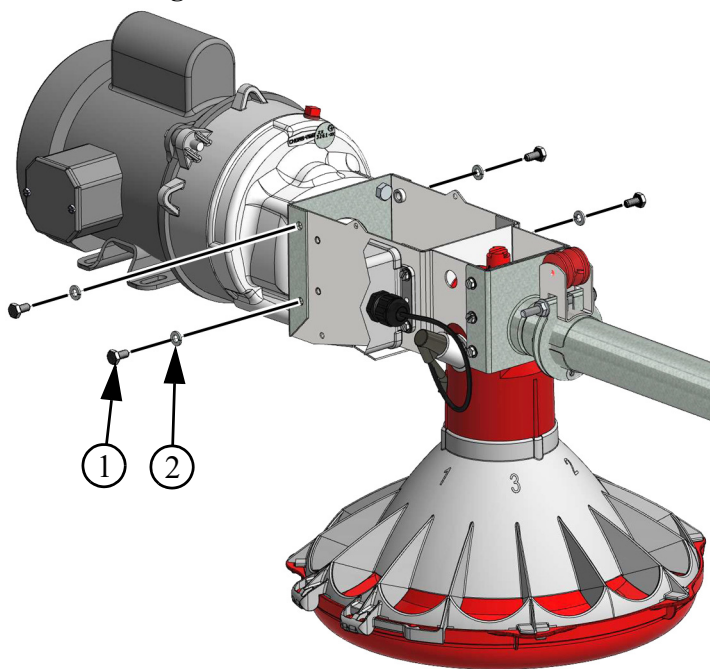

Item	Description	Part No.
1	1/4-20 x .50 Bolt	1487
2	.259 x .489 x .062 Lock Washer	1667

Figure 27. Attaching the Gearhead to the Control Unit Body

8. Install the Metal Water Tight Connector (**Item 1**) in the Power Unit (**Item 2**). Cut the Flex Conduit (**Item 3**) to length. Slide the wires from the end control through the Flex Conduit (**Item 3**). Install the Flex Conduit (**Item 3**) in the connectors.

9. See “Power Unit Wiring” on page 39 for wiring for various Power Units.

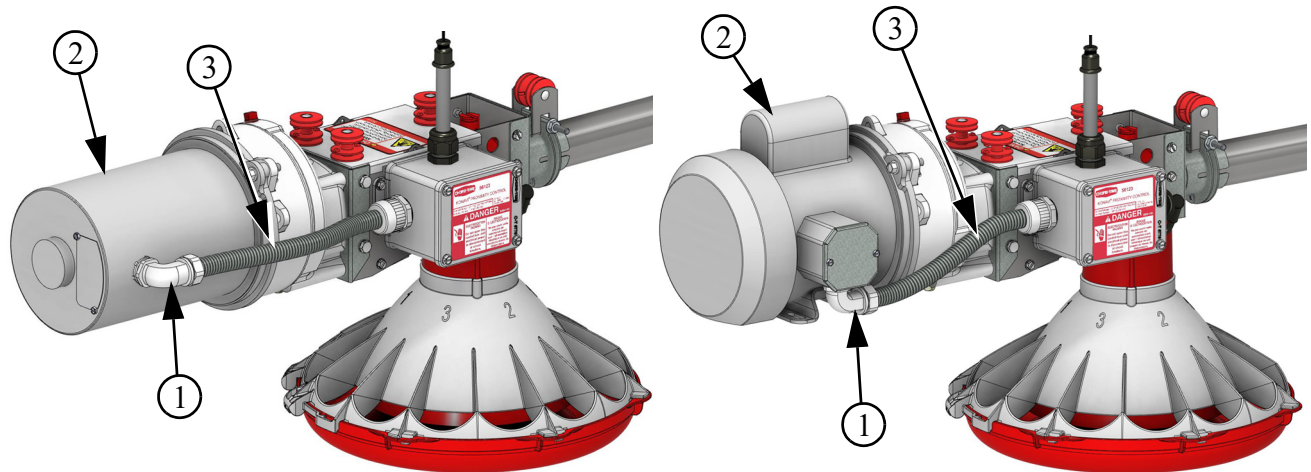

Motor without Conduit Box

Motor with Conduit Box

Item	Description	Part No.
1	Water Tight Connector	23810
2	Power Unit	Varies
3	Flex Conduit	Varies
*Items 1 & 3 in		

Figure 28. Installing Water Tight, Cutting and Installing Conduit

10. Attach all covers and wire according to the wiring section of this manual.

Auger Stretch



Use caution when working with the Auger--springing auger may cause personal injury.

7" [180 mm] per 100' [30 m]. Example: A 300' [90 m] feeder line requires 21" [500 mm] of stretch. Measure the amount of stretch from the rear edge of the boot and cut the Auger at that point. (See Figure 29.)

1. Pull on the loose end of the Auger at the boot once or twice until it begins to stretch, then release it slowly. This will bring the auger to its natural length.
2. Measure and mark the Auger at the point where it is to be cut (See Auger Stretch above).
3. Pull the Auger until the Mark is out far enough to allow for the Anchor and Bearing Assembly (Item 1) to be installed and use Vice Grips to hold the Auger in place as shown.
4. Cut the Auger at the Mark.
5. Insert the Anchor and Bearing Assembly into the Auger and feed it between the two Auger Spirol Pins (Item 2) until the Auger touches the Washer on the Anchor and Bearing Assembly. Tighten the Auger Clamp Screws (Item 3) to 10-12 ft.-lbs. **Note:** Over tightening the Set Screw may cause damage to the Auger Clamp.

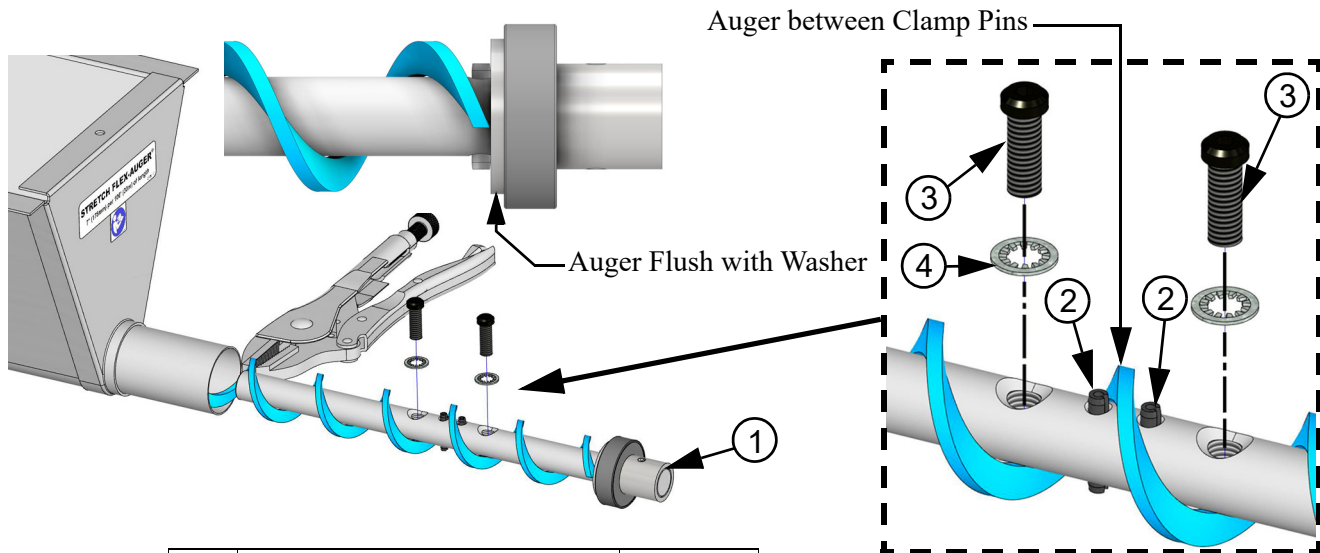
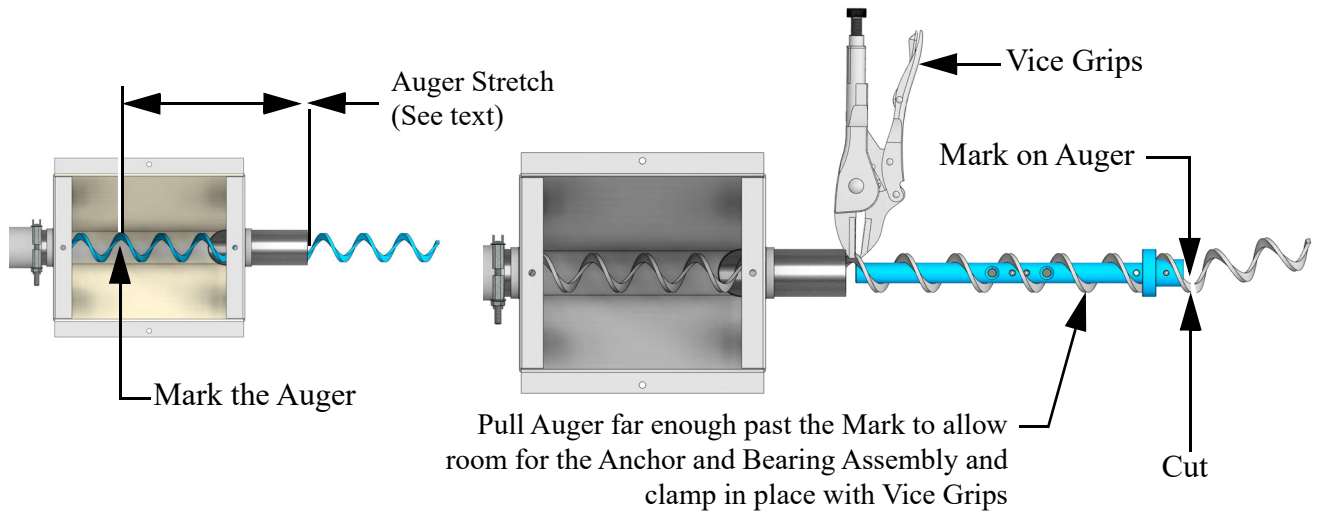

Item	Description	Part No
1	Anchor and Bearing Assembly	39372
2	Spirol Pin	2960-1
3*	5/16-18 x .875 Auger Clamp Screw	47867
4*	5/16 Lock Washer	48609
*Included in Anchor and Bearing Assembly		

Figure 29. Auger Installation (Stretch)



Use caution when working with the Auger--springing auger may cause personal injury

6. Carefully remove the Vice Grips to allow the Auger to snap into place.
7. Install the Stub Tube (Item 1), Cap (Item 2), and Tube Clamp (Item 3) as shown.

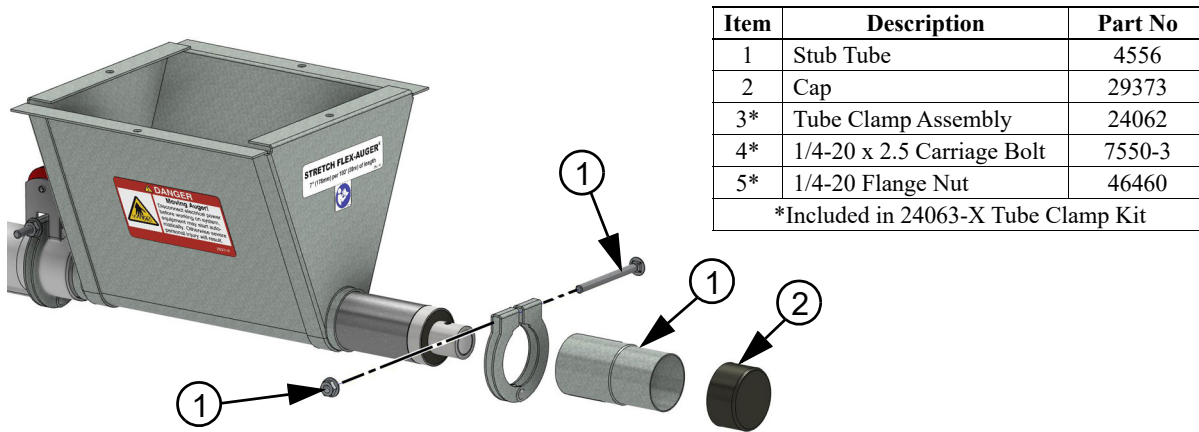

Figure 30. Stub Tube, Cap and Clamp

8. Place the cannonball in the boot.

Auger Brazing

The auger should be brazed if it is necessary to splice or lengthen it. A bronze, flux coated rod is recommended. The ends of the auger should butt against each other, **DO NOT THREAD INSIDE EACH OTHER**. The joint should be well filled with no sharp edges or rough corners to wear against the tube. To align the auger for brazing, lay it in angle or channel iron and clamp it firmly in place. Use low heat. Allow the joint to air cool; rapid cooling will cause the auger to become brittle.



BE CAREFUL WHEN WORKING WITH THE AUGER!

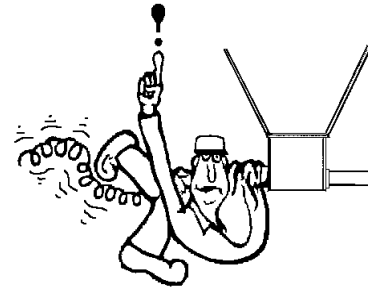

Lap the Auger ends approximately 1" [25 mm]

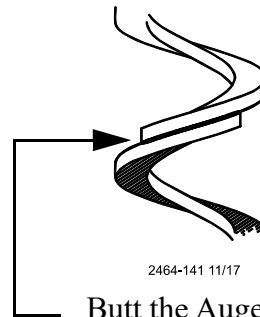
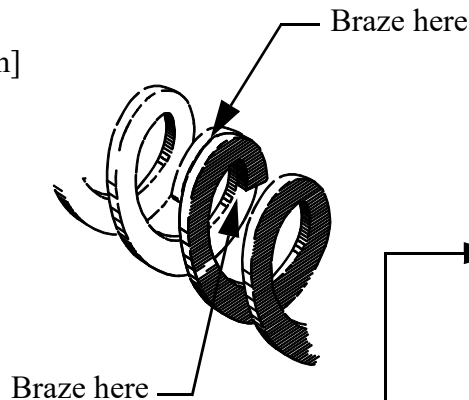
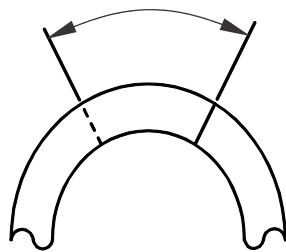

Butt the Auger ends together. **DO NOT** thread the Auger together

Figure 31. Auger Brazing

Mid-Line Control

Mid-Line Control Units are available for the KONAVI® Feeder. The Mid-Line Controls are shown in **Figure 32.**

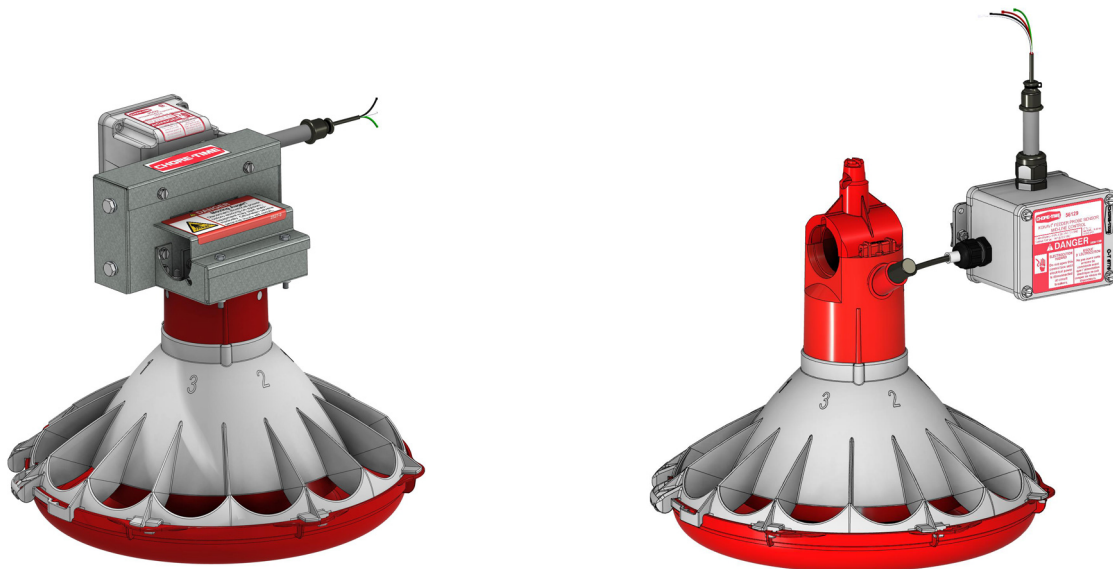

57700 KONAVI® MID LINE Control with Mechanical Switch

57699 KONAVI® Mid Line Control with Proximity Sensor

Figure 32.Mid-Line Controls

Location/Planning

The Mid-Line Control makes it possible to operate the feeding system when birds are confined away from the End Control Unit. Chore-Time recommends placing the Mid-Line Control Feeder at least 2 pans away from the curtain or partition. (See **Figure 33.**)

New Feeder Lines

Leave one Feeder Pan assembly off the Feeder Control Tube at the point where the Mid-Line Control needs to be placed. The feeder line can be assembled and suspended before attaching the Mid-Line Control; or the Mid-Line Control may be attached to the Feeder Tube when the other pans are installed.

Existing Feeder Lines

Cut the Support Cone and remove the Feeder Pan at the location where the Mid-Line Control will be installed.

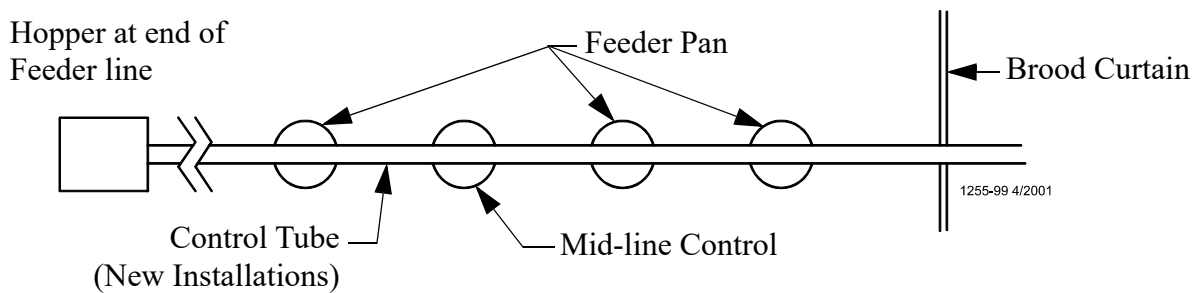

Figure 33.Mid-Line Control Location Diagram

Installation

Feeder Tube Outlet Holes

New Feeder Lines: Skip to next section.

Existing Feeder Lines: Enlarge the outlet hole to approximately 1" [2.5 cm] diameter for the Mid-Line Control, plus enlarge (2) outlet holes in front (to the hopper end) of the Mid-Line Control. Use unibit to enlarge hole size.

Note: Be sure there are no burrs inside the tube to catch the auger.

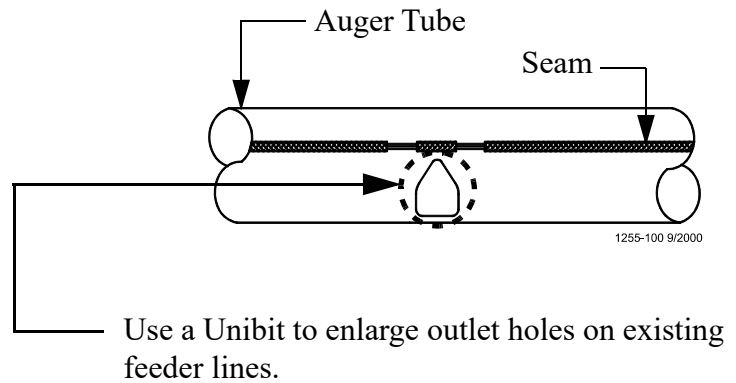

Figure 34. Enlarging Outlet Holes

Attaching the Mid-Line Control

Mid-Line Control with Mechanical Switch

1. Remove the two hex head screws on the control top.
2. Lift off the control top.
3. Cradle the feeder tube in the control housing. The feeder tube may have to be turned slightly to allow the pan to hang straight.
4. Clamp the control in place by inserting tabs on the control top into the slots on the control body. Install and tighten the two hex head screws previously removed.

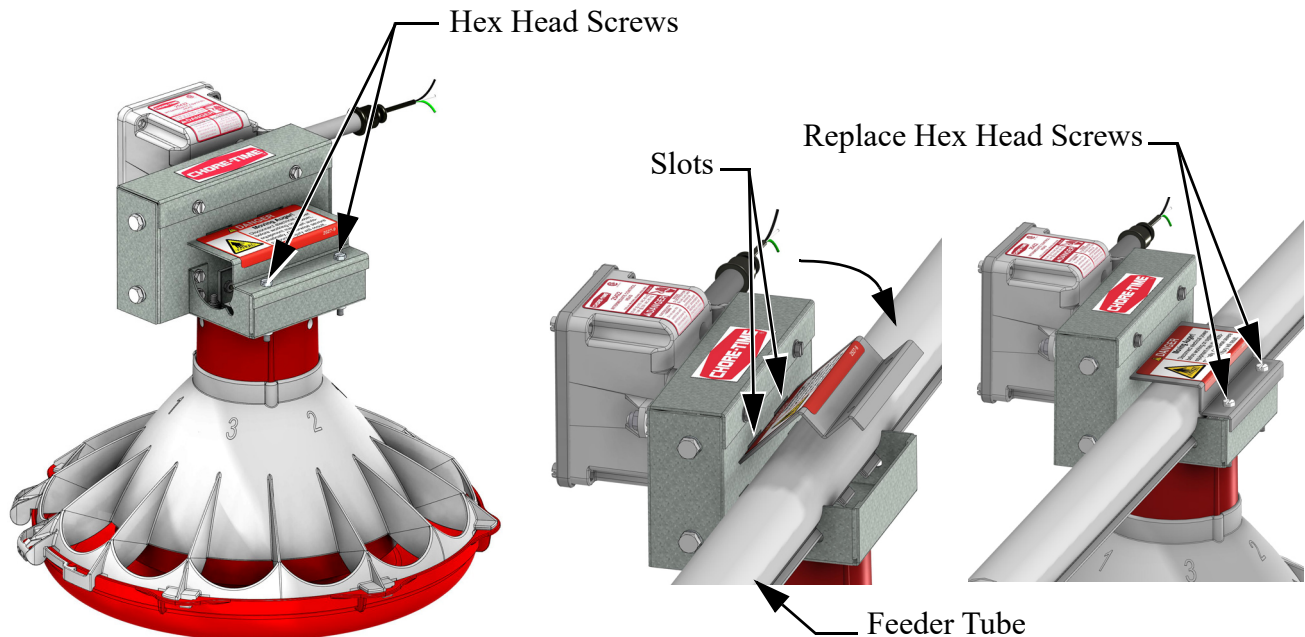
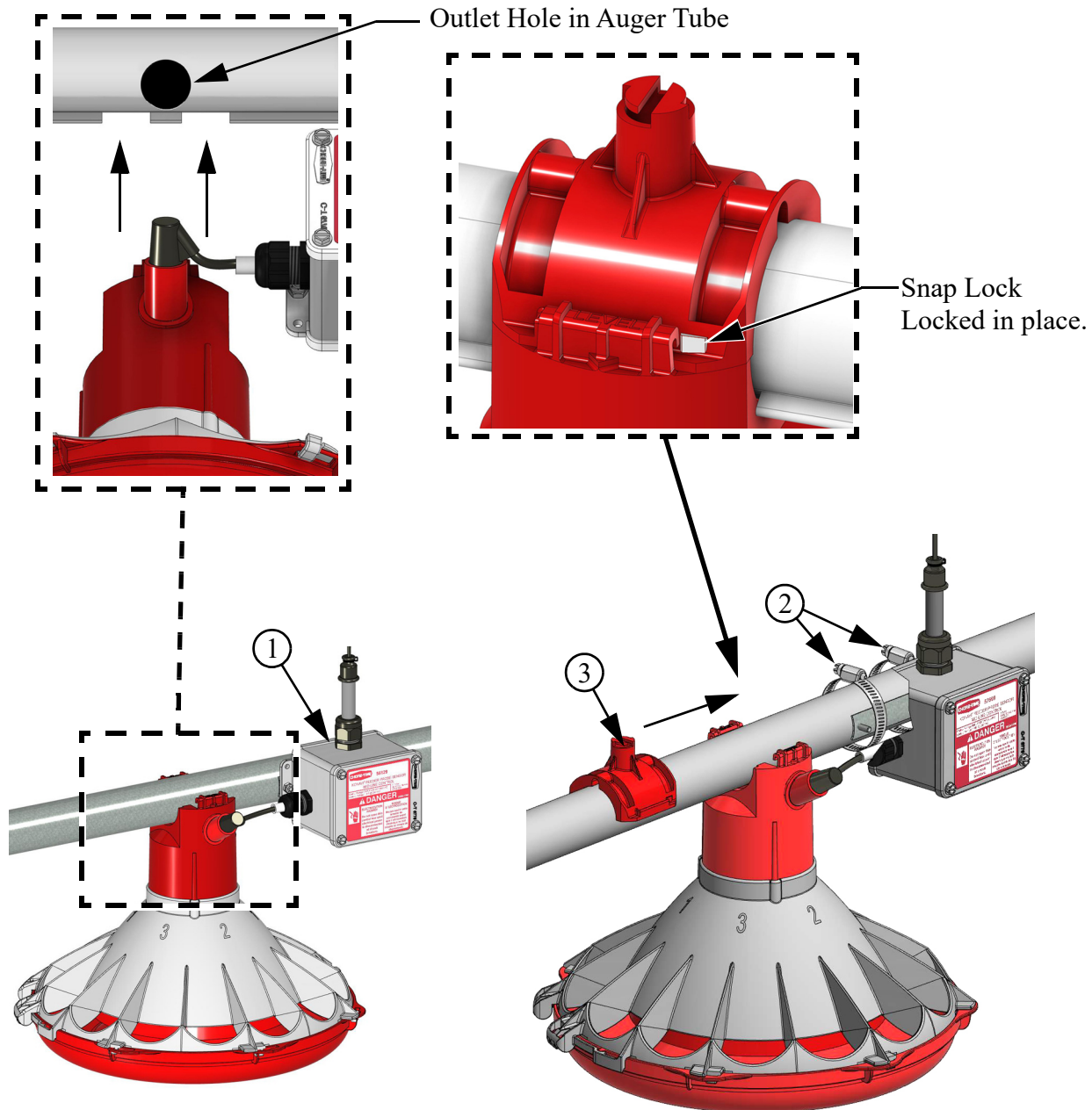

Figure 35. Mid-Line Control Installation

Mid-Line Control with Proximity Sensor Control

1. Assemble the Mid-Line Control (Item 1) to the Feeder Tube using a Konavi Two Piece Top (Item 3) as shown in Figure 36.
2. Attach the Switch Box Assembly to the Feeder Tube with a Hose Clamp (Item 2) as shown.
3. Install a toggle switch, out of reach of the birds, to disconnect power to the Mid-Line Control. This allows the Mid-Line Control to serve as standard feeder when not used as a control feeder.
4. Wire the Mid-Line Control as shown in the wiring diagram section of this manual.



Item	Description	Part No.
1	Midline Control	57699
2	Tube Clamp	3527
3	Konavi Two Piece Top	55820

Figure 36. Installing the Mid-Line Control with Proximity Sensor

Anti-Roost Assembly

1. Unroll the bulk anti-roost cable. Note: If the cable is unrolled as shown in **Figure 37.**, taking 5 loops of the coil with one hand, then changing hands to remove 5 loops as it is unrolled, it will lie flat during installation.

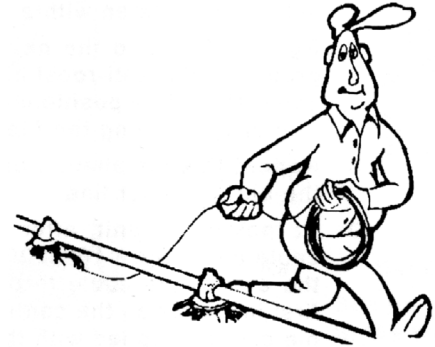

Figure 37. Unrolling Cable

2. Start at the hopper end of the line and form a loop around the anti-roost bracket. For best results, make a double loop around the anti-roost insulator in the center groove of the insulator and fasten with a 1/16" cable clamp as shown in **Figure 38.**
3. Insert the cable in the insulator on the top of each Grill Support between the hopper and the next anti-roost bracket.

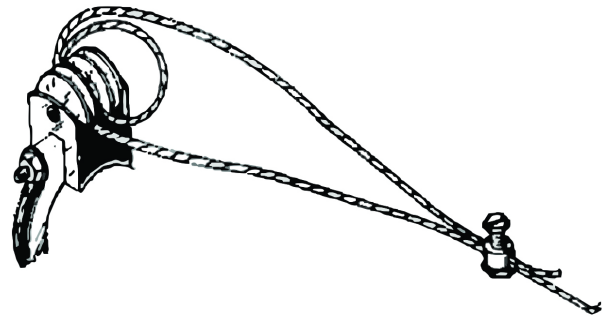

Figure 38. Anti-Roost Cable at the Hopper

4. Attach a spring in the center groove at the second anti-roost bracket and cut the cable at this point. (See **Figure 39.**)
5. Thread the ends of the cable through the end of the spring. Pull the cable tight so that there is 3/4" to 1" [20 to 25 mm] of stretch in the spring. Clamp the cable to form a loop and cut off any excess. (See **Figure 39.**)
6. Attach the cable to the insulator. For best results, make a double loop around the anti-roost insulator in the center groove of the insulator and fasten with a 1/16" cable clamp as shown in **Figure 39.**
7. Run the cable to the next insulator, attach a spring in the center groove at the anti-roost bracket and cut the cable at this point. The cable should be positioned in the insulator built into the top of each grill support along the feeder line.
8. Repeat this installation until the anti-roost cable is installed along the entire feeder line.

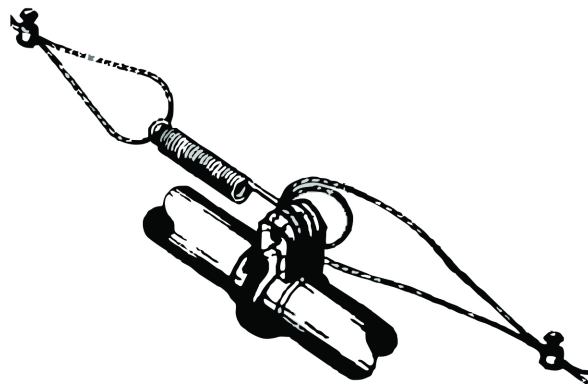

Figure 39. Anti-Roost Cable Mid-Line Connection

9. At the control unit, after clamping the cable to the spring, cut the cable about 8" to 10" [200 to 250 mm] longer than necessary. Feed the end of the cable through the center of the spring, around the first insulator on the control unit, and clamp the cable using the cable clamp supplied with the control unit. (See **Figure 40**). Install the wire form on the control unit insulators. Be sure the guard snaps into the retainers molded into the insulators. (See **Figure 40**).

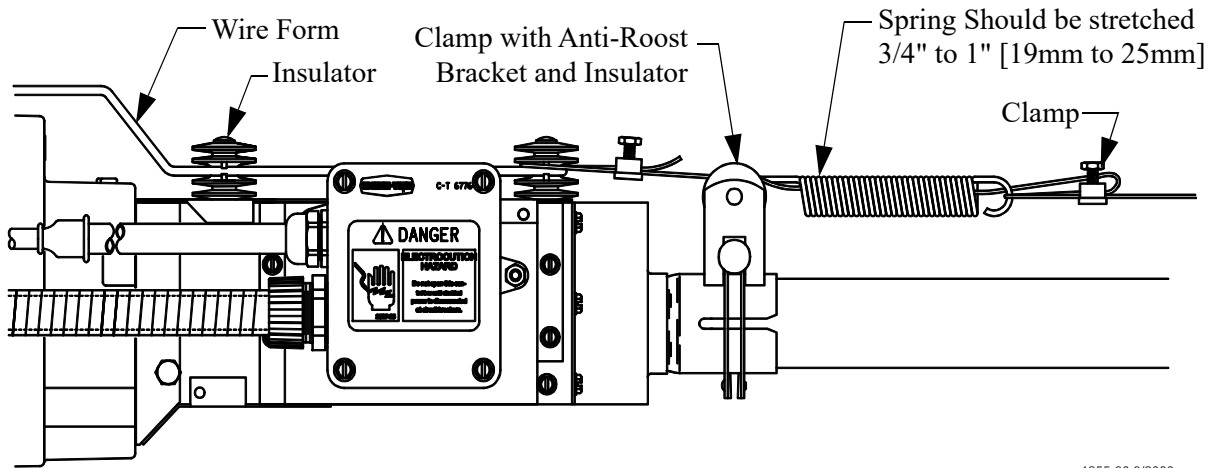

Figure 40. Anti-Roost Installation at the Control Unit

1255-90 9/2000

10. Install the Poultry Trainer or Line Charger, as shown in **Figure 41**. The Poultry Trainer is used to power all Anti-Roost lines in a house.

- The Line Charger is used to power individual Anti-Roost lines in a house. (See **Figure 41**).
- Route the charger wire from the Poultry Trainer or Line Charger to the Anti-Roost system.
- Secure the Charger Wire to the Anti-Roost cable, using a cable clamp.

11. The anti-roost system *must* be on a separate electrical circuit, allowing the system to be disconnected by a switch near the door.

Remember, the anti-roost system should be grounded through the poultry trainer.

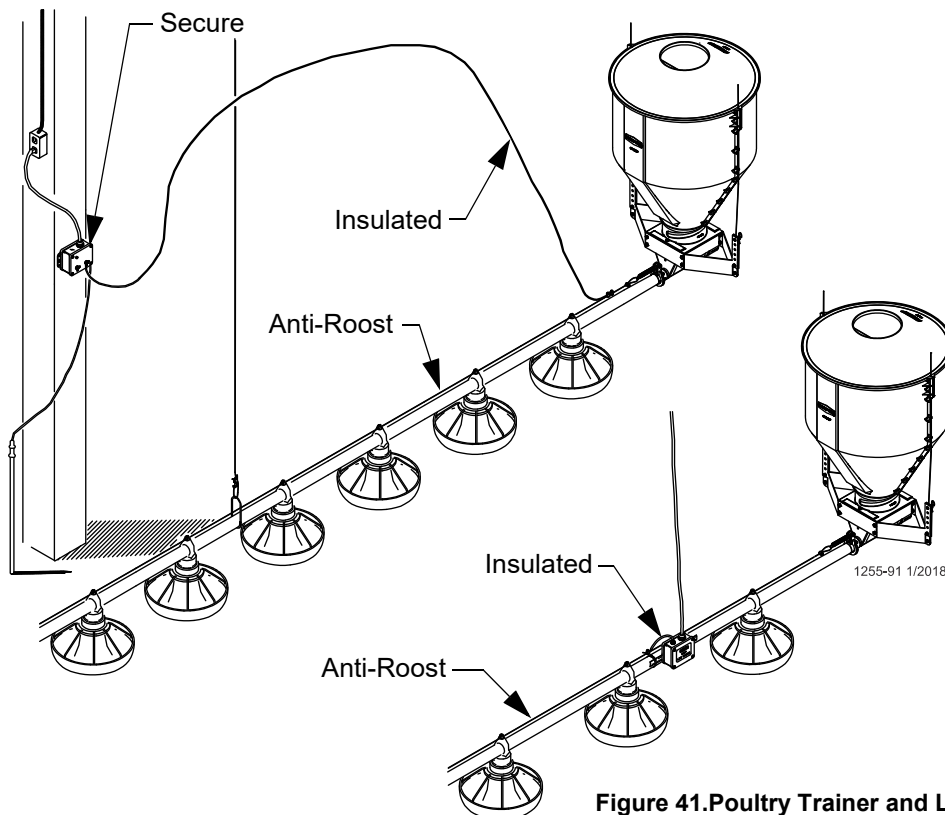
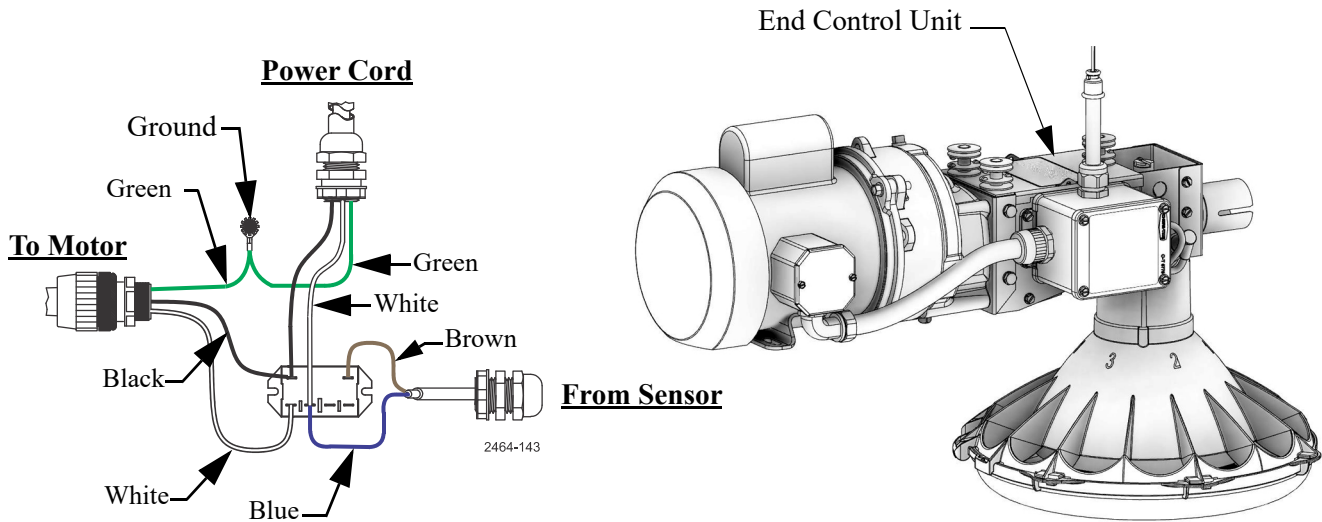

Figure 41. Poultry Trainer and Line Charger

Wiring

End Control with Proximity Switch Internal Wiring



Proximity Sensor Wiring Diagram

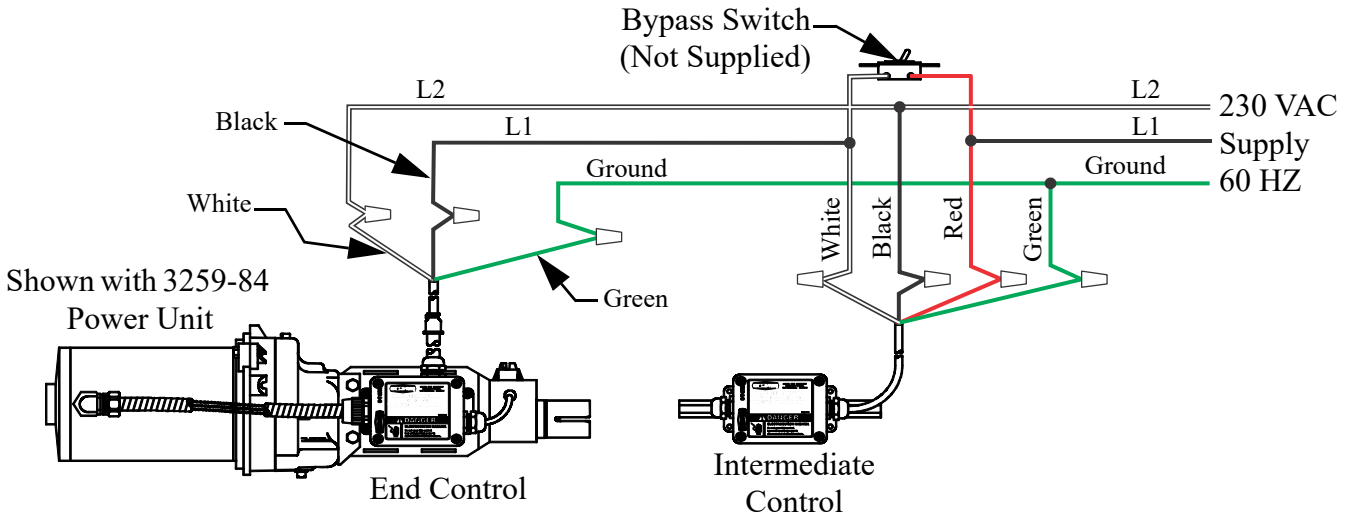

Mid-Line Control with Proximity Sensor Internal Wiring

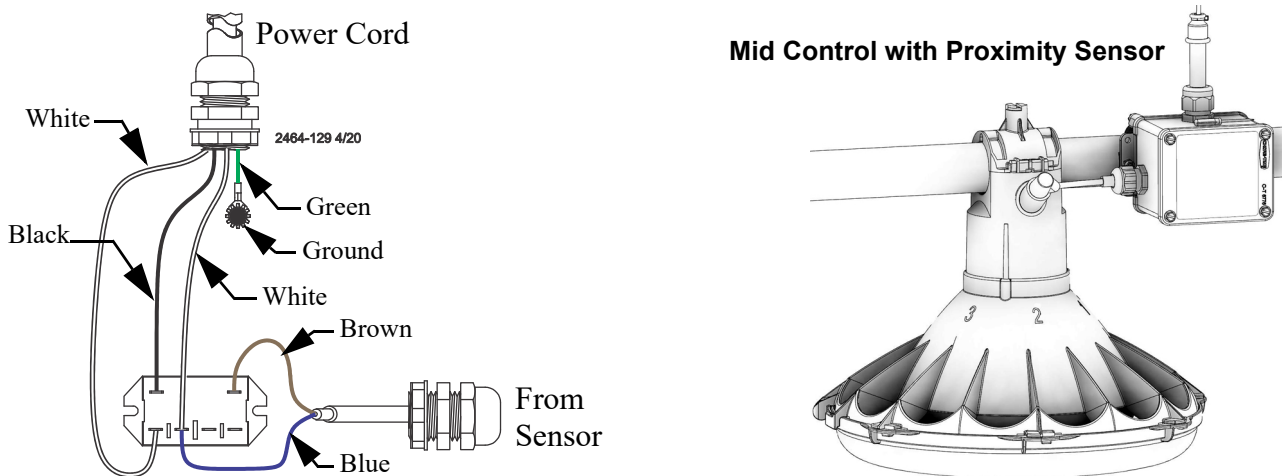

Mechanical Switch Single Phase Wiring Diagram

From disconnect or Control disconnect
220/230 Volts 50/60 HZ

Feeder Line Motor 220/230
Volts 50/60 HZ. Single Phase

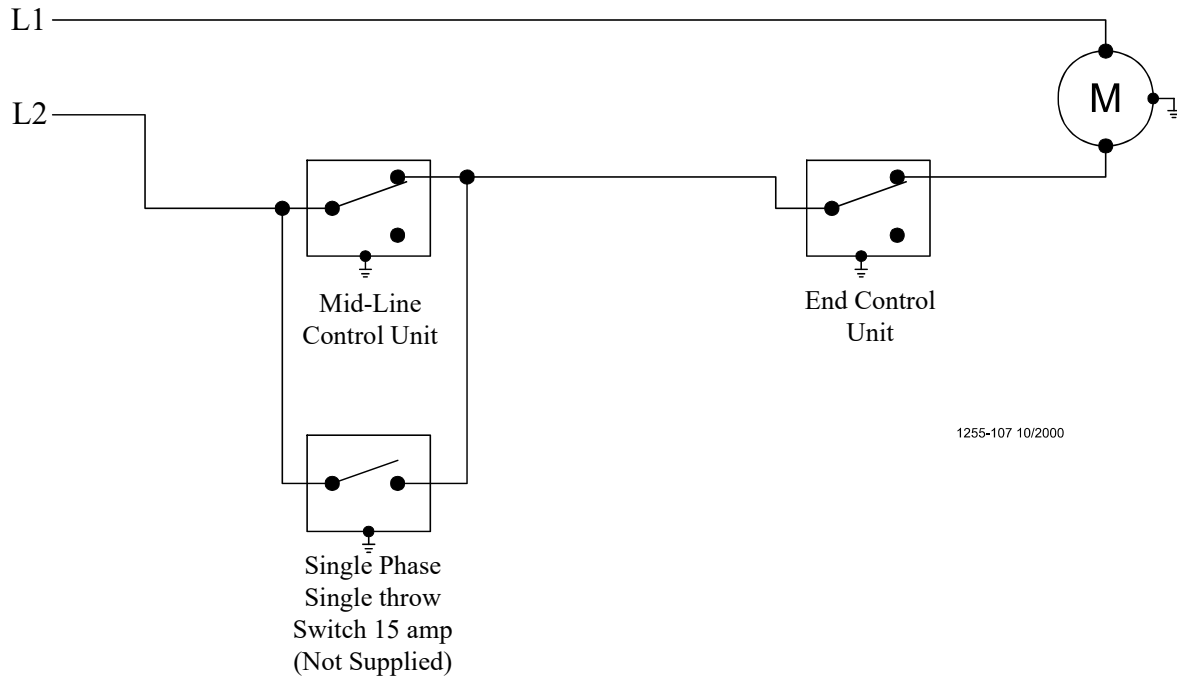

Mechanical Switch Single Phase Wiring Diagram with Motor Starter

SINGLE PHASE

FROM DISCONNECT OR
CONTROL DISCONNECT
220/230 VOLTS 50/60 HZ

TO ADDITIONAL
FEEDER LINES

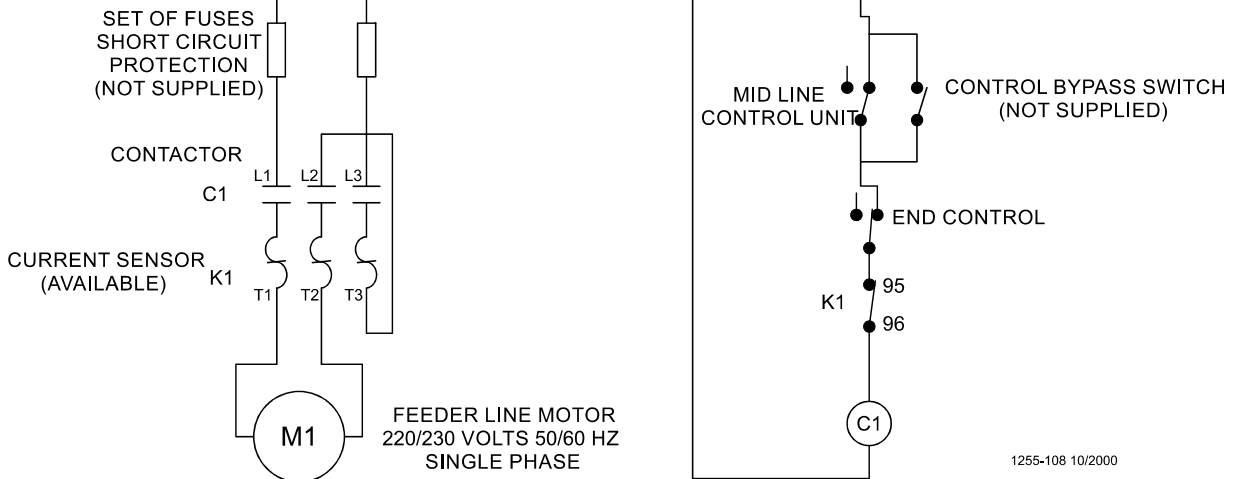

Mechanical Switch Three Phase Wiring Diagram: 220 V.

From disconnect or Control disconnect 220 Volts 50 HZ Three Phase

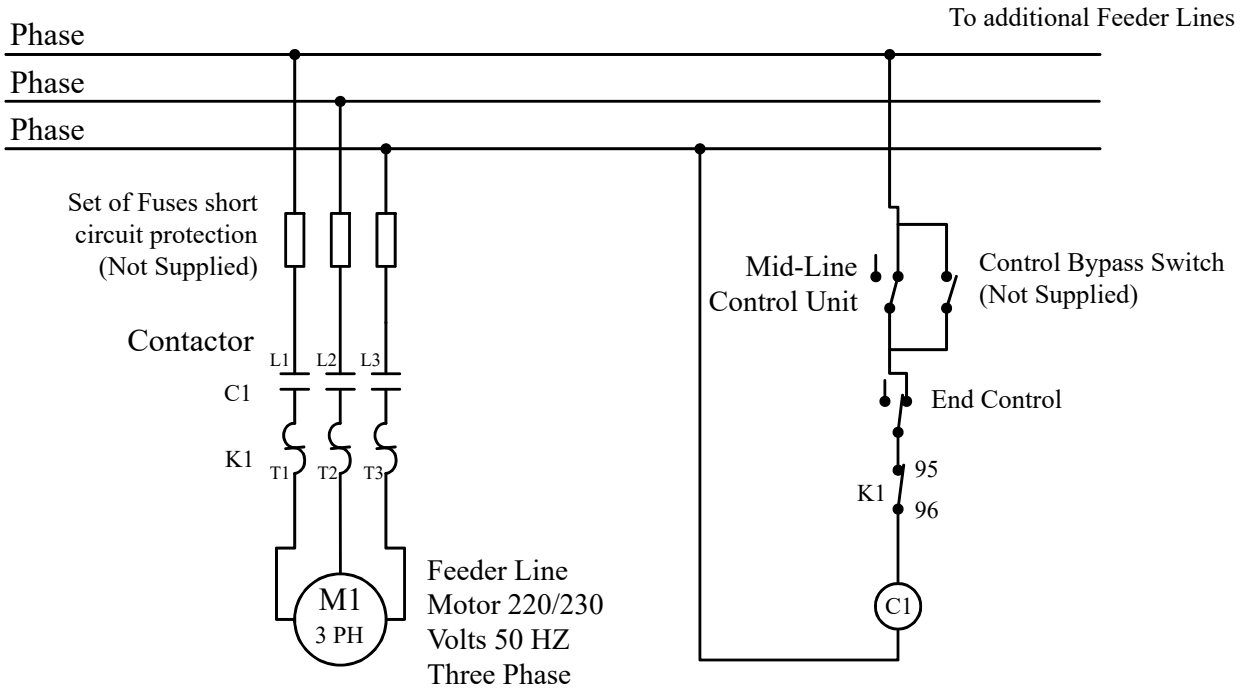

1255-109 10/2000

Mechanical Switch Three Phase Wiring Diagram: 380/415 V.

From disconnect or Control disconnect 380/415 Volts 50 HZ Three Phase

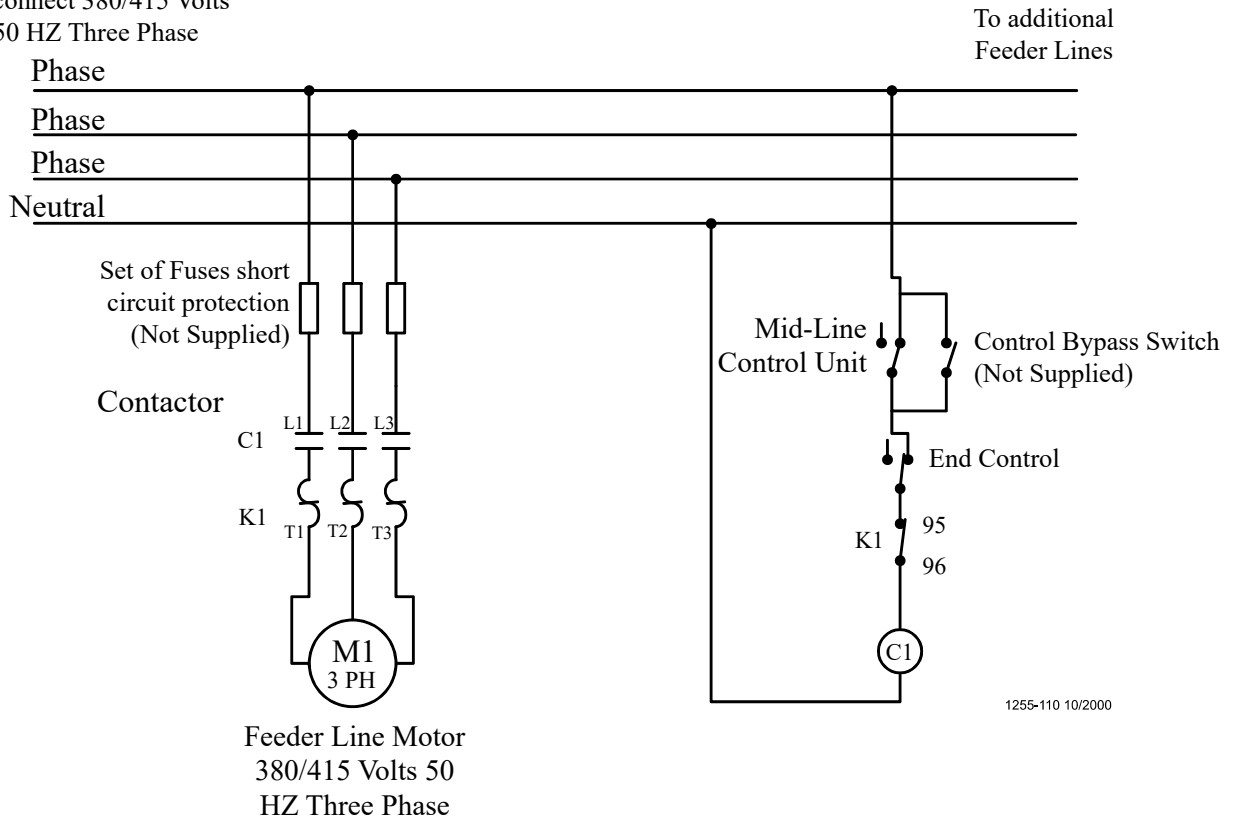

1255-110 10/2000

Electronic Sensor Three Phase Wiring

From disconnect or Control disconnect 220/380 Volts
50 HZ Three Phase

To additional Feeder Lines

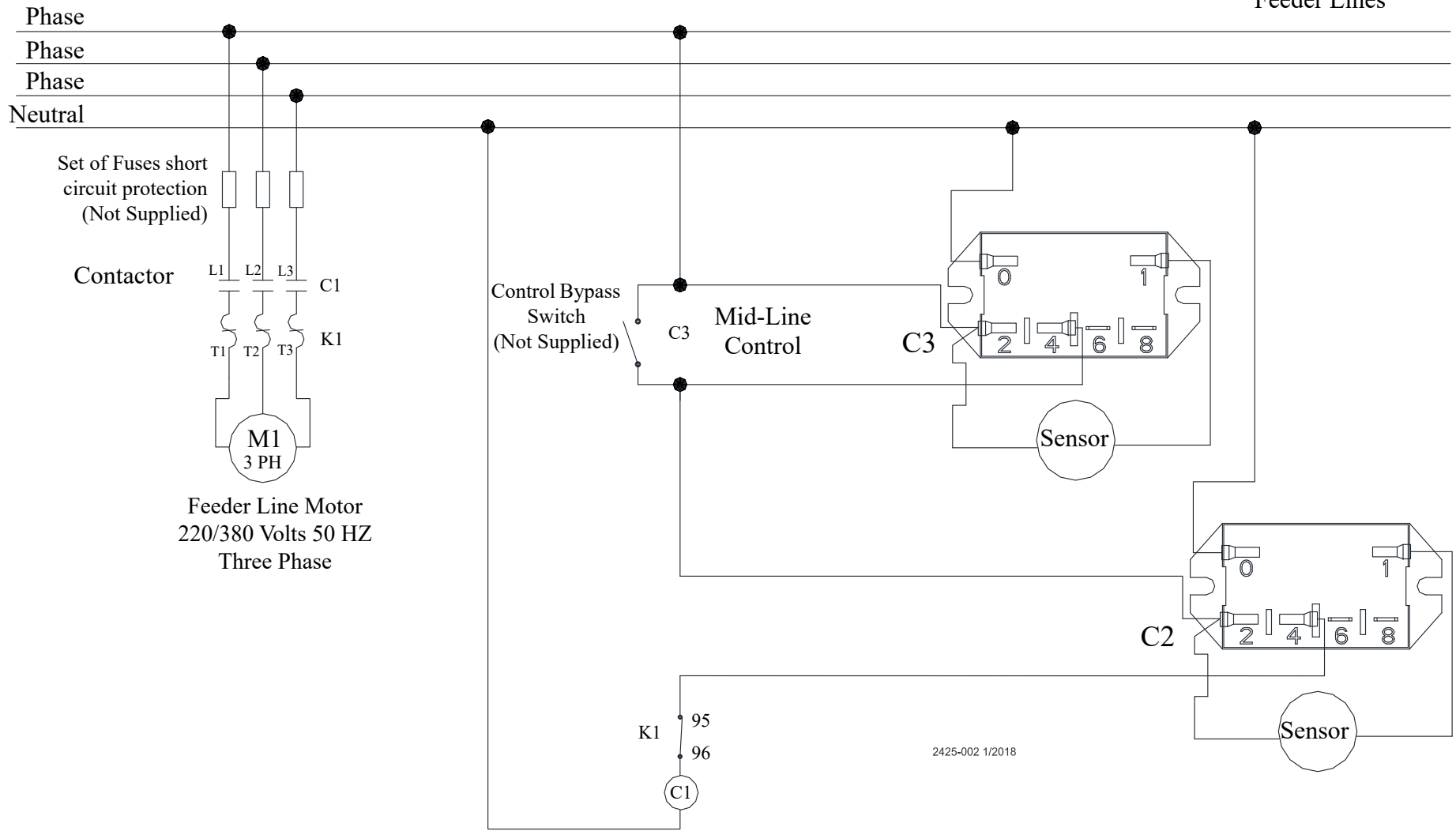

2425-002 1/2018

Power Unit Wiring

3259-84 Power Unit (4229 Motor) Wiring

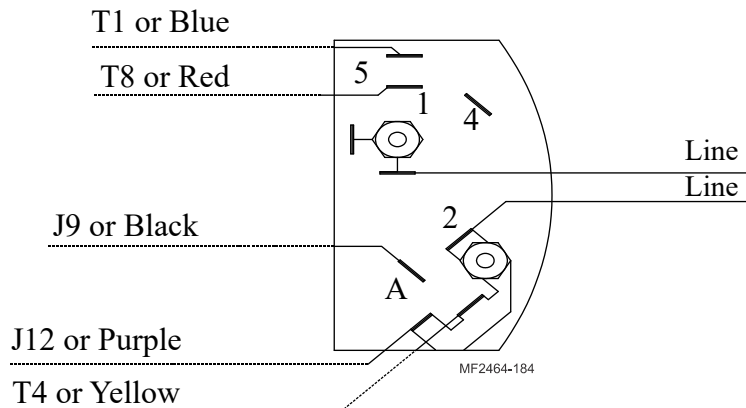

3259-85 Power Unit (5703 Motor) Wiring

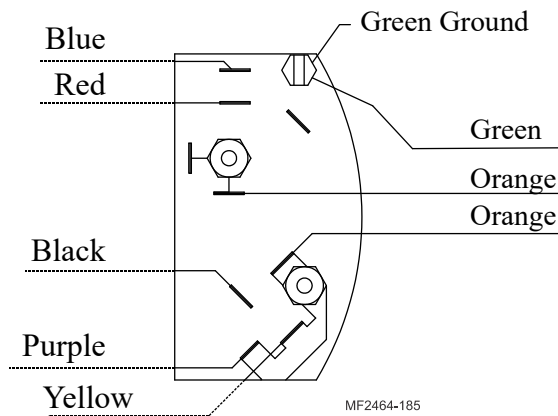

3259-98 Power Unit (5977 Motor) Wiring

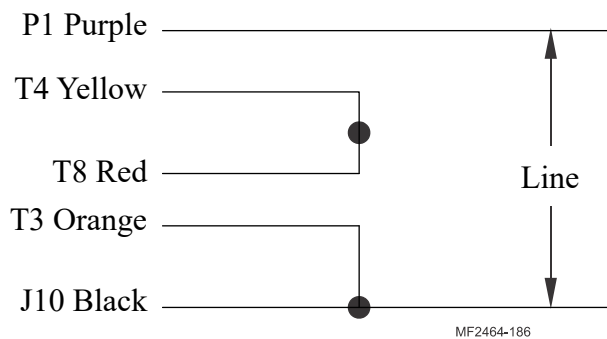

3259-100 Power Unit (28031 Motor) Wiring

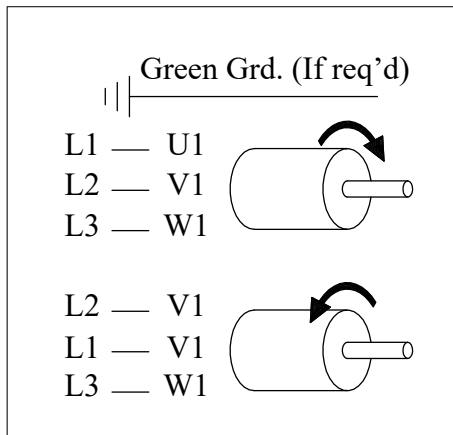

2464-187 07/20

220V-240V

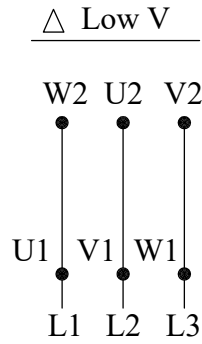

380V-400V

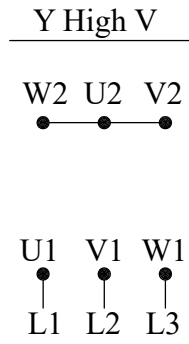

3259-128 Power Unit (24624 Motor) Wiring

208-230V

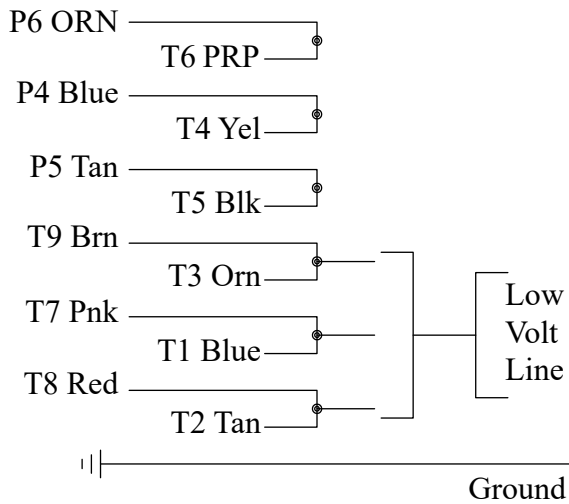

380-460V

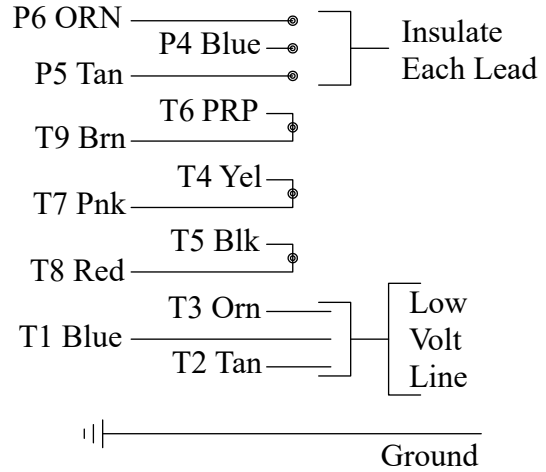

2464-188 07/20

Troubleshooting

ALWAYS DISCONNECT POWER TO THE SYSTEM WHEN SERVICING OR MAINTAINING THE EQUIPMENT. FAILURE TO DISCONNECT POWER MAY CAUSE INJURY OR DEATH.

Service and maintenance work should be done by a qualified technician only.

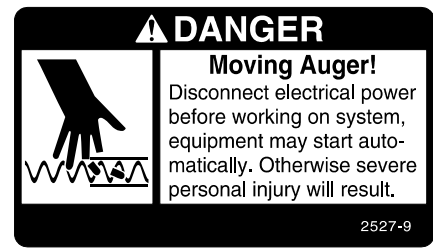

Problem	Possible Cause	Corrective Action
None of the feeder lines will operate	No power supplied to equipment	Replace burned fuses or reset circuit breaker Make sure voltage required is supplied
	Time Clock or relay defective	Replace Time Clock or relay
	Time Clock improperly programmed	Refer to Programming the Time Clock section and reprogram the Time Clock
	Feeder line will not operate	Check motor cord plug at control unit and control unit plug at outlet for connection
Feeder line will not operate	Power unit cord not plugged in sufficiently to make contact	Check cord for continuity Replace if defective
	Motor cord wires are broken at plug or where cord enters motor	Push motor overload reset button to reset
	Power Units thermal overload tripped	Adjust switch according to the Switch Adjustment Procedure in the maintenance section
	Control unit switch defective or out of adjustment	Polish auger by running 50 lb (20 kg) increments of feed out to pans
Motor overloads frequently	Oil on new auger loads motor excessively when feed is carried for first time	Check line voltage at the motors Check starting current draw at motors Wiring of adequate size is essential to feeder operation
	Inadequate power reaching motors	Check hopper boot, control unit and pan outlet holes for foreign objects Remove obstruction
	Object caught in the auger; motor runs, stalls, then auger spins in reverse	Replace bearing Slowly ease auger back into tube Be careful not to damage the bearing when reinserting the auger
Auger runs erratically	Frozen or cracked bearing at boot anchor	Shorten the auger
	Insufficient stretch in auger	Remove obstruction
	Obstruction in the auger	Repair or replace damaged auger
Auger tube or boot wears out rapidly (Noisy feeder operation)	Auger is bent or kinked	Auger must not be positioned over weld on anchor Check for bent or damaged auger
	End of auger is riding up on anchor weldment	Replace plastic shipping plug with vent plug
Oil leaking out of seals on power unit	Gearhead vent plug not installed	Replace seal
	Defective gear head seal	Add more operating time to feeding period
Not enough feed supplied to the feeder pans	Insufficient time programmed on the time clock	Adjust switch according to the Switch Adjustment Procedure in the maintenance section
	Feeder line control unit switch out of adjustment	

Maintenance

Floor Feeding System Maintenance

The KONAVI® Feeders require minimum maintenance. However, a routine periodic inspection of the equipment will prevent unnecessary problems.

Maintenance should be done by a qualified technician.

ALWAYS DISCONNECT POWER TO THE SYSTEM WHEN SERVICING OR MAINTAINING THE EQUIPMENT. FAILURE TO DISCONNECT POWER MAY CAUSE INJURY OR DEATH.

Gear Head Maintenance

Check the oil level in the gear heads at installation and every 6 months. The Pipe Plug, on the side of the gear head, indicates proper oil level. Add SAE 40W oil when necessary.

The oil in the gearheads should be replaced every 12 months with new SAE 40W oil

1. Remove the bottom Pipe Plug to drain the oil. Discard used oil in accordance with local and national codes.
2. Wipe any debris off the magnet on the bottom Pipe Plug and reinstall. Remove the side Pipe Plug and (top) Vent Plug.
3. Set the power unit in the horizontal position.
4. **2-Stage Gearheads:** Add approximately 9 oz. (266 ml) of SAE 40W oil through top hole. This should be just enough oil to reach the side Pipe Plug.

3-Stage Gearheads: (3261-9, 3261-12, 3261-14): Add approximately 13 oz. (384 ml) of SAE 40W oil through top hole. This should be just enough oil to reach the side Pipe Plug. Install the side Pipe Plug and (top) Vent Plug.

Vent/Oil Fill Plug



1660-22 1/2001

Check the oil level in Gearhead at installation.

Check the oil level every 6 months.

Check the oil level at the side plug if oil is needed use SAE 40W.

Oil capacity for the 2 stage gearhead is 9 oz [266 ml]

Oil capacity for the 3 stage gearhead is 13 oz [384 ml].
The oil should be changed every 12 months.

Figure 42. Gearhead Maintenance

Check equipment for loose hardware after the first flock and then every 6 months--including the Anchor Block. Tighten if necessary.

Mechanical Switch Adjustment procedure for Control Units

Refer to (See Figure 43.)

- A. Turn the adjustment nut counter-clockwise until the switch clicks.
- B. Turn the adjustment nut clockwise until the switch clicks.
- C. Turn the adjustment nut counter-clockwise 3/4 turn.

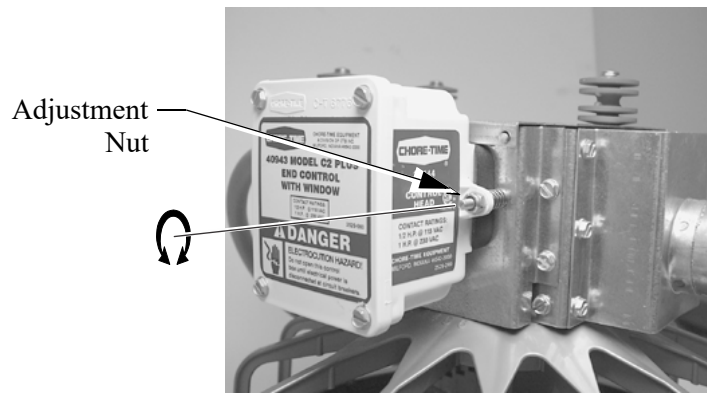

Figure 43. Switch Adjustment

1660-23 1/2001

Proximity Sensor Adjustment

Sensitivity Timer: The Feeder Comes with the Sensitivity Timer adjustment Screw factory set and Glued in position. (Do not Adjust).

Time Delay: The Delay Time is Factory Set to 3 Minutes. See Figure 44.

To adjust the Time Delay:

- For less time — turn Time Delay Selector counter-clockwise.
- For more time — turn Time Delay Selector clockwise.

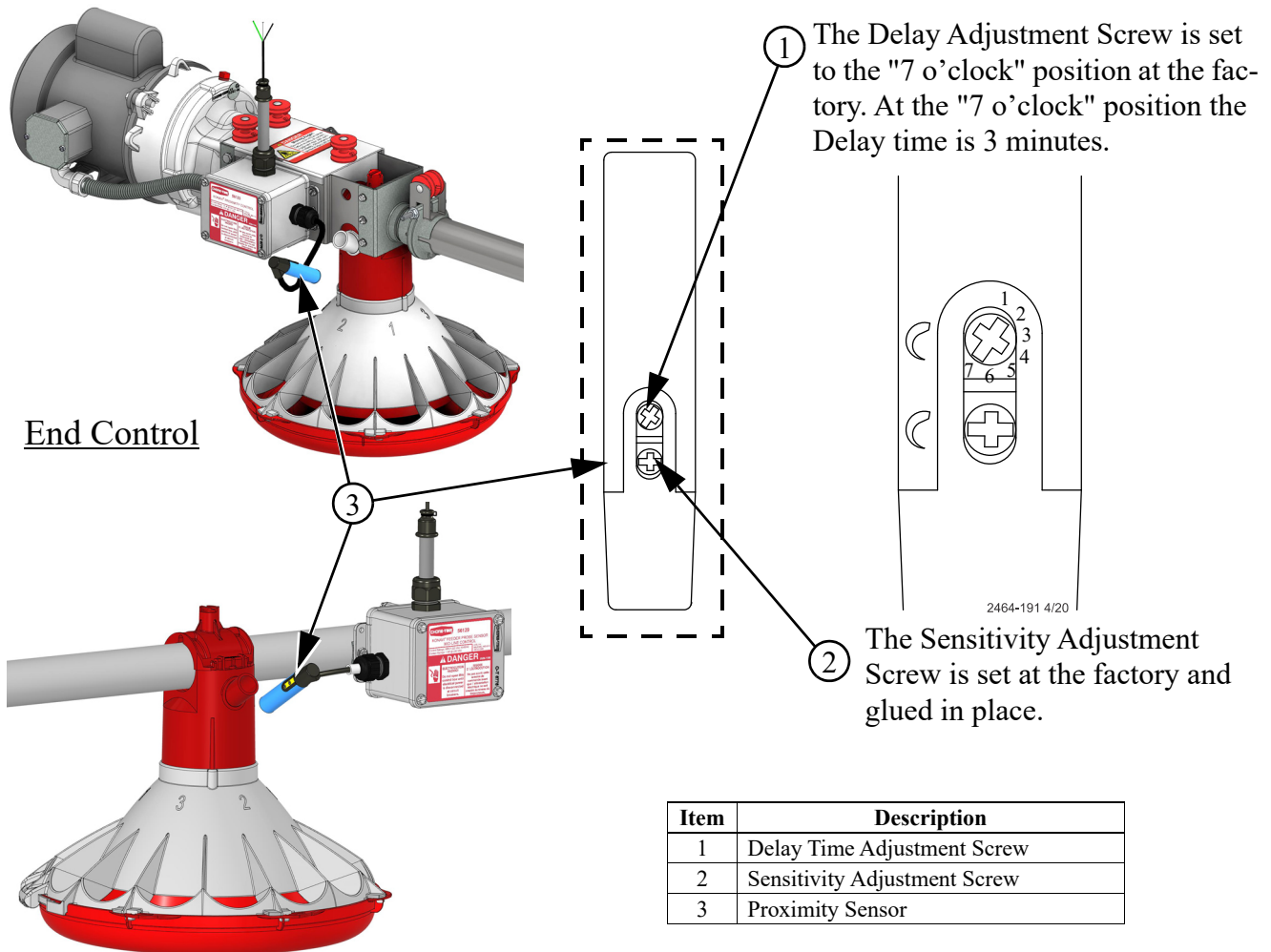

Figure 44. Proximity Sensor Adjustment

End Control

Mid-line Control

Feeder Line

Keep anti-roost cables tightly stretched. This increases the effectiveness of the electro-guard anti-roost system and keep the pans from being tilted when birds push against them.

Remove all feed from the feeder when there are no birds in the house and when the building is washed and disinfected.

Turn the feeders off prior to removing the birds from the house. This will allow them to clean the feed out of the pans.

If the system is not to be used for an extended period of time, remove all the feed from the feeder lines and feeder pans.

Disconnect power to the system to prevent accidentally starting the system.

If the system must be disassembled, extreme caution must be used to prevent injury from springing auger. Refer to **Figure 45**.

1. Disconnect power to the entire system.
2. Loosen the Tube Clamp on the bearing at the hopper end of the system. Remove the Tube Clamp and Bearing Retainer.
3. Pull the Anchor and Bearing Assembly and approximately 18" [45 cm] of auger out of the boot.

CAUTION: Stand clear...the auger may spring back into the tube.

BE CAREFUL WHEN WORKING WITH AUGER!

4. Place a clamp or locking plier securely on the auger to prevent it from springing back into the auger boot.
5. Loosen the setscrew in the bearing assembly shaft and remove the Anchor and Bearing Assembly from the auger.

To reinstall the Anchor and Bearing Assembly:

1. Insert the Anchor Assembly into the auger, guide the tip of the auger between the two roll pins in the center of the anchor. Continue to guide the auger until the tip of the auger hits the flat washer. Tighten the setscrews in the center of the anchor until they touch (See **Figure 45**.)
2. **Carefully** remove the locking pliers while holding onto the Anchor and Bearing Assembly and auger securely. **Slowly** ease the auger back into the tube. Use caution. If the auger is allowed to spring back, the bearing race may crack. Install the Bearing Retainer and fasten with a tube clamp. Keep the Bearing Retainer flush with the end of the anchor for safety.

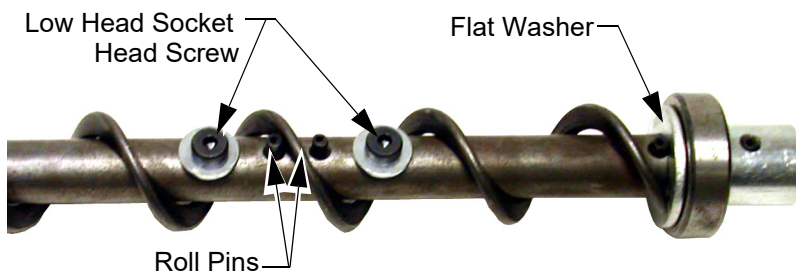
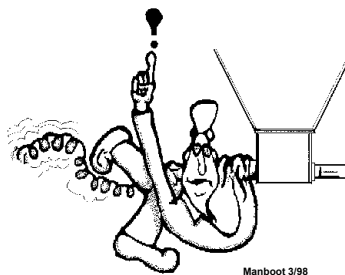

Figure 45. Auger and Anchor Bearing Connection



Power Lift Winch Maintenance

Refer to **Figure 46**.

Grease the winch every 6 months with 1 to 2 shots of common industrial or automotive grease.

Remove any feed build-up in the Safety Switch Boxes in the Control Units.

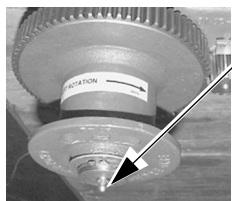

1660-24 6/2001

Figure 46. Maintenance to the Power Lift Winch

Grease the Power Lift Winch every 6 months with 1 to 2 shots of common industrial or automotive grease. **DO NOT OVER GREASE!**

It may be necessary to periodically re-tighten the shocker cable. Be sure to disconnect power to the shocker before servicing the equipment.

Management

This section provides you with valuable information concerning feeder operation and management. It is important that you read this information and understand how the feeding system was designed to operate. Once you become familiar with the system, you may *custom operate* it to fit your individual needs.

Initial Start-up of the Feeding System

The Feeding System should be operated prior to birds being housed to make sure the installation is correct, the switches function properly, and to fill the feeder lines with feed.

There are two typical layouts for the feeding system that was determined prior to the installation. Normally if the building is 400' [122 m] or over, a center house hopper set-up is used. (See Figure 47.) For buildings under 400' [122 m], the hopper is placed at one end and the control pan/power unit at the other end. (See Figure 48.)

It is common practice to use partial house brooding during the early days of broiler production. For buildings that have the feeder split in the center (center hopper set-up), normally only the feeders that are in the brood area are used during brood time. For buildings that have the hopper at one end, brooding can be done on the motor end or an optional mid line control pan(s) can be placed on the feeder line.

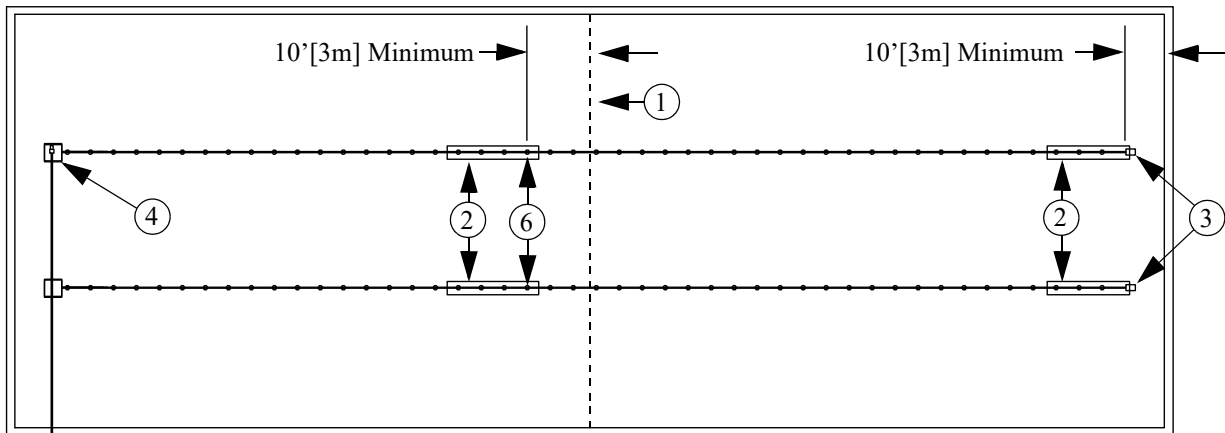
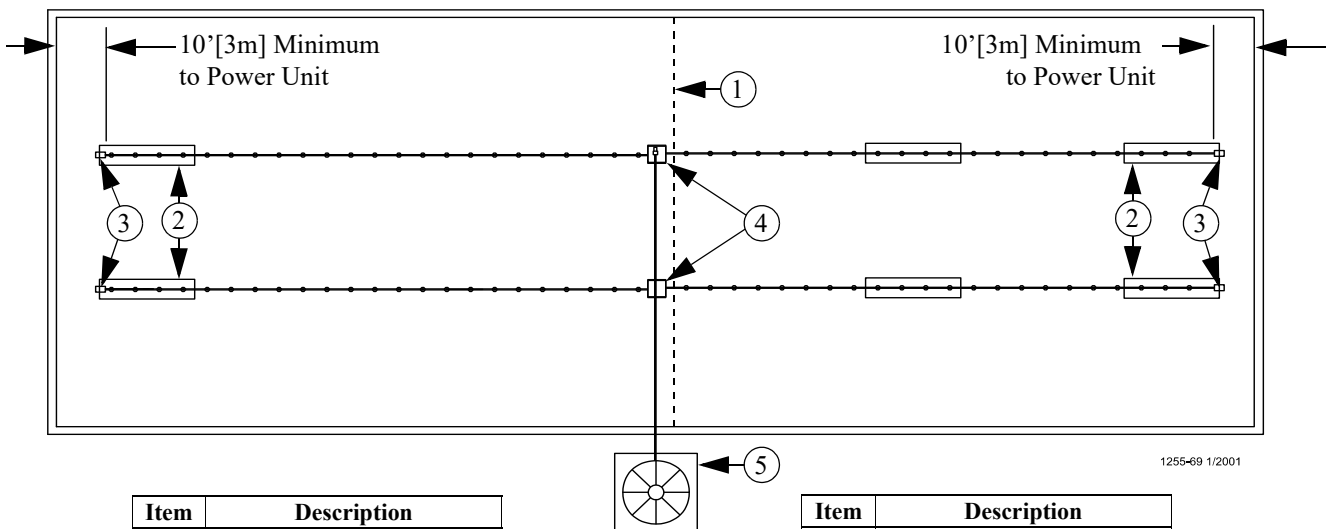

Figure 47. Component location diagram for systems over 400 feet [122 m]. (Top View).



Item	Description
1	Brood Curtain
2	Control Tube
3	End Control and Power Unit

Item	Description
4	Feeder Hopper
5	Feed Bin
6	Midline Control

Figure 48. Component location diagram for systems up to 400 feet [122 m]. (Top View).

The feeder tubes and auger are supplied from the factory with a protective oil coating that will cause the system to deliver feed at a reduced rate. The oil coating will also create a larger load on the power unit (motor) until the system has been initially purged with feed, and becomes broken in.

To operate

1. Lower feeder lines so the feed pans are resting on the floor and the feed flood windows are completely open. Although the major weight of the feeder lines will be on the floor, do not remove all the weight from the suspension system and allow the cables to become slack.
2. Apply power to the feeder lines to check the operation. Allow to operate empty for 1-2 minutes.

NOTE: For feeder lines that have mid line controls, the recommended bypass switch(s) are wired into the system for selection of partial or full house control. Select the switch so the mid line control is functional. As the feeder operates, the feed will stop at the mid line control pan.

3. With the shut-off slide on the feed bin boot closed, energize the Flex-Auger® fill system. After operation of approximately 1-2 minutes, open the boot slide 1/2 way to allow feed to be conveyed to the feeders.
4. Once feed begins to be dispensed into the feed hopper(s), manually shut-off the fill system.
5. Apply power again to the feeder lines. Operate the fill system manually to dispense approximately 50 lb. [23 kg] increments of feed into the feed hopper(s). Allow the feed hopper to become empty for 30 seconds between each increment to reduce load on the feeder motor. Continue this procedure until feed has been dispensed to all the feeder pans. When the feed reaches the control pan, the feeder line will be shut-off.
6. Once the feeder lines have been initially filled with feed, manually dispensing feed in 50 lb. [23 kg] increments will no longer be necessary. The shut-off slide on the Flex-Auger® fill system may be completely opened. Refer to the Flex-Auger fill system Operator's Manual for information when multiple feed bins are used.

General Operation of the KONAVI® Feeders

These recommendations are the guideline to aid producers with the use of the feeding system. With experience a feeding program will be developed to enhance the feeding systems performance. Several factors such as feed content, type of birds, climate, lighting programs, and etc. may dictate change from these recommendations.

The KONAVI® feeders have a feed flood windows which allows the feeder pan, when lowered to the floor, to be filled with feed for the brooding of young birds. Start young birds with the feeder line lowered so the feed pans are resting on the floor and the feed flood windows are completely open. Although the major weight of the feeder lines will be on the floor, do not remove all the weight from the suspension system and allow the cables to become slack.

When using KONAVI® feeders it is advisable but not necessary to provide supplemental feed to young birds during the first few days. The Pan height is shallow enough for birds to get feed from day 1. Non-supplemental feeding requires additional feeding space and planning when choosing house layout. This is especially true when partial house brooding is used (refer to **“Initial Start-up of the Feeding System” on page 45**). Supplemental feeders such as the CHORE-TIME® E-Z START™ Chick Feeder, provide extra feeding space and access to the feed.

With the feeders lowered to the floor and the feed flood windows open, the operation of the feeder will allow a high level of feed to be placed into the feed pans making it easy for the birds to find feed, adapt to the feeder, and begin to eat.

Do not operate the feeding system on automatic (full demand feed) when the feed windows are open. Chore-Time recommends opening the feed windows for the first 3 to 5 days (max). The feeders will need to be operated at least 2 times a day for the first 5 days, and thereafter, 3 times a day or more as needed, while the windows are open. If it is not possible to operate the feeder manually 1-3 times a day during the brood time (windows open), then a time clock should be utilized to limit the number of times and length of time the feeder can operate. Failure to do one of the above will create the possibility of an excessive high feed level in the feed pans and the birds to waste feed.

DO NOT OPERATE THE FEEDING SYSTEM ON AUTOMATIC (FULL FEED) WHEN THE FEED WINDOWS ARE OPEN.

As the birds grow and become acclimated to the feeder pans, the feeder will need to be raised to the grow-out position. Before raising the feeder, it is recommended to allow the birds to eat the feed level down below the feed flood windows. This will ease the process of the feed flood windows closing properly.

Use the suspension system to raise the feeder(s) line. As the feeder is raised the feed flood windows will close. Continue raising the feeder lines until the feed pans just begin to clear the floor or litter.

IMPORTANT: When raising the feeder to the grow-out position, make sure the feed pans are to the point of just clearing the floor.

This will insure the feed will properly flow out into the feeder pan. When the feeder is raised to just clear the litter, there may a few places where the litter is lower and the pans seem too high. Do not be concerned as the birds will level the litter and at this young bird age, there will be sufficient feeder space.

Feeder Pan Setting

The feeders should be set on the #2 position for most applications. The adjustment settings are easy to understand and change. Setting numbers are embossed on both sides of the grill so they may be easily seen from either side of the feeder line. (See Figure 49.) Feed texture and consistency, type of bird, or other variables may make it necessary to change to another feed setting position. The combination of proper pan height, feeder setting, and feeder operation will result in optimum feeder performance. (See Figure 50.) The operator will learn what performs best for his/her situation with experience.

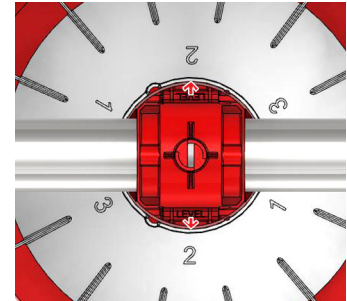

Figure 49. Feeder Pan Setting

End Control Pans

At installation time, the end control was placed to 10 feet [3 m] from the end of the building to allow the birds access around the end of the feeder line.

The End Control Pan should be set to the #1 position. This ensures that the Feed will be consumed in the Control Pan, calling for feed to the rest of the Feed Line.

Mid Line Control Pan

The Mid Line Control is placed on the feeder line when partial house brooding is desired. It is important the mid line control be installed at least 2 feeder pans away from the curtain or partition so the birds will activate the feeder line. The feed setting for the mid line control should be the same as the rest of the feeder pans on the feeder line. A toggle switch or disconnect is used to bypass the power to the mid line control. This allows the mid line control to serve as a standard feeder after brooding. The feeder can be changed from full house operation to partial house brooding with the activation of the switch.

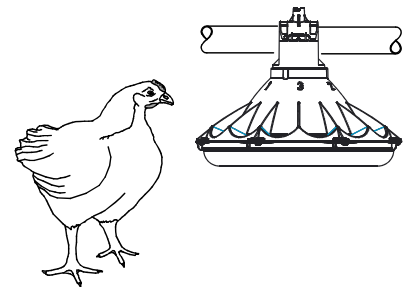

Figure 50. Feeder Pan height adjustment

Controlling the Feeders (optional equipment)

A time clock control is used with the feeding system to reduce excessive feeder operation time and limit feed wastage. The basic use of a time clock control is to allow periods of time during the day for the birds to reduce the feed level in the feeder pans and to limit the possibility of the birds creating a high feed level and wasting feed. This is not to be confused with lighting programs that have become very common place. If lighting or intermittent lighting programs are to be used, the use of the time clock control will be limited to just the light period. **Caution should be used to not restrict the feed from the birds during the light period.** Experience with the feeding system will determine how the time clock control is used.

The KONAVI® Feeding Systems may be controlled by the #34385 Control Panel or the #34574 Time Clock Control. Refer to the instructions supplied with each control for information.

Electro-guard Operation

The electro-guard chargers should be operated on a separate electrical circuit so the anti-roost system can be shut off using a switch next to the entrance door when someone enters the building. Birds are less likely to become wild and flighty if the anti-roost is off when people are in the building.

Parts List

150# Plastic Hopper

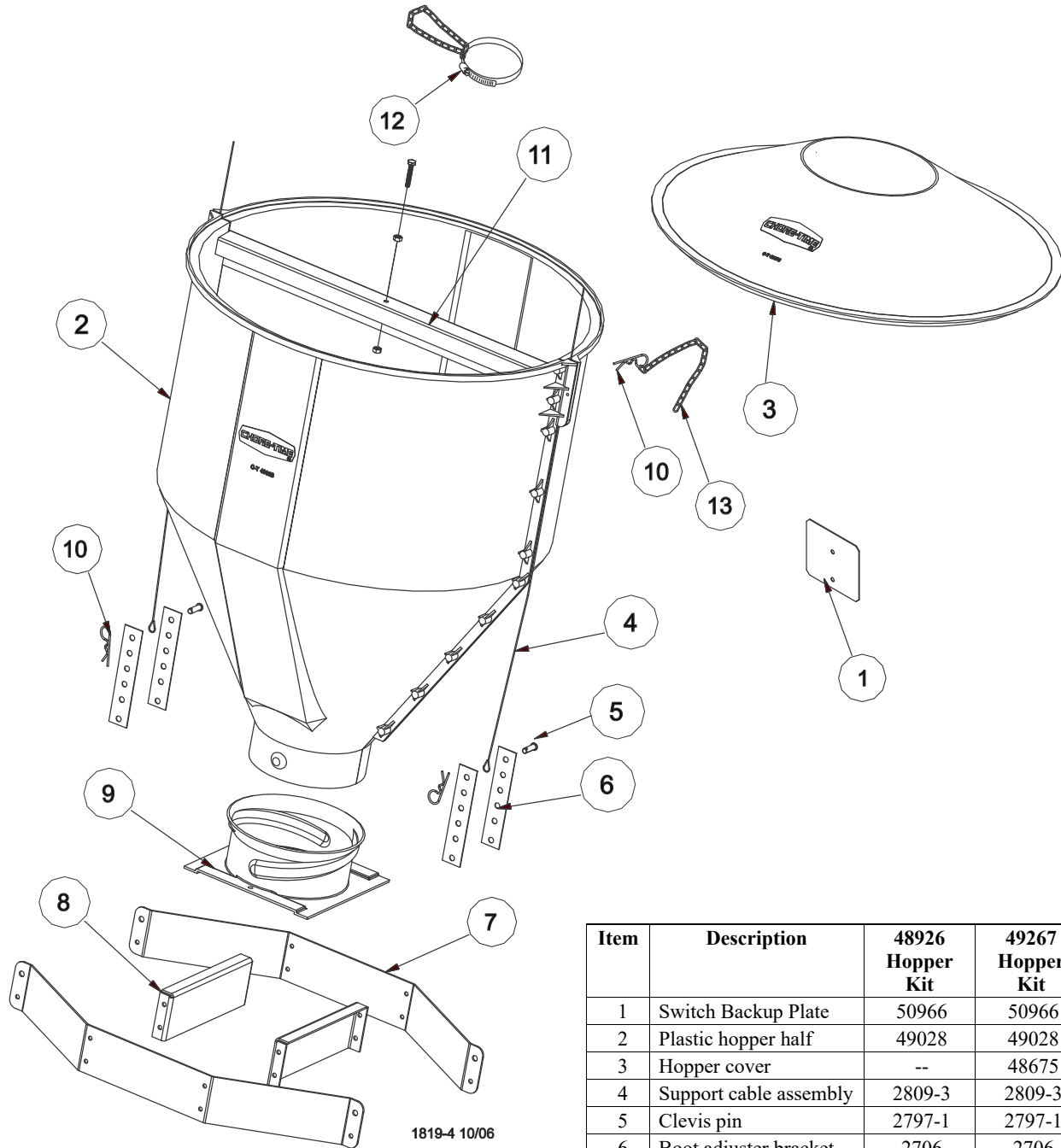

Item	Description	48926 Hopper Kit	49267 Hopper Kit
1	Switch Backup Plate	50966	50966
2	Plastic hopper half	49028	49028
3	Hopper cover	--	48675
4	Support cable assembly	2809-3	2809-3
5	Clevis pin	2797-1	2797-1
6	Boot adjuster bracket	2706	2706
7	Suspension angles	48679	48679
8	Suspension brace	48680	48680
9	Twist lock collar	49041	49041
10	Hair pin	2664	2664
11	Cross brace	49029	49029
12	Drop tube support	14367	14367
13*	Chain	2128	2128

*Item must be ordered in either 100 ft or 250 ft quantities, 2128-100 is 100 ft and 2128-250 is 250 ft.

200# Hopper Components

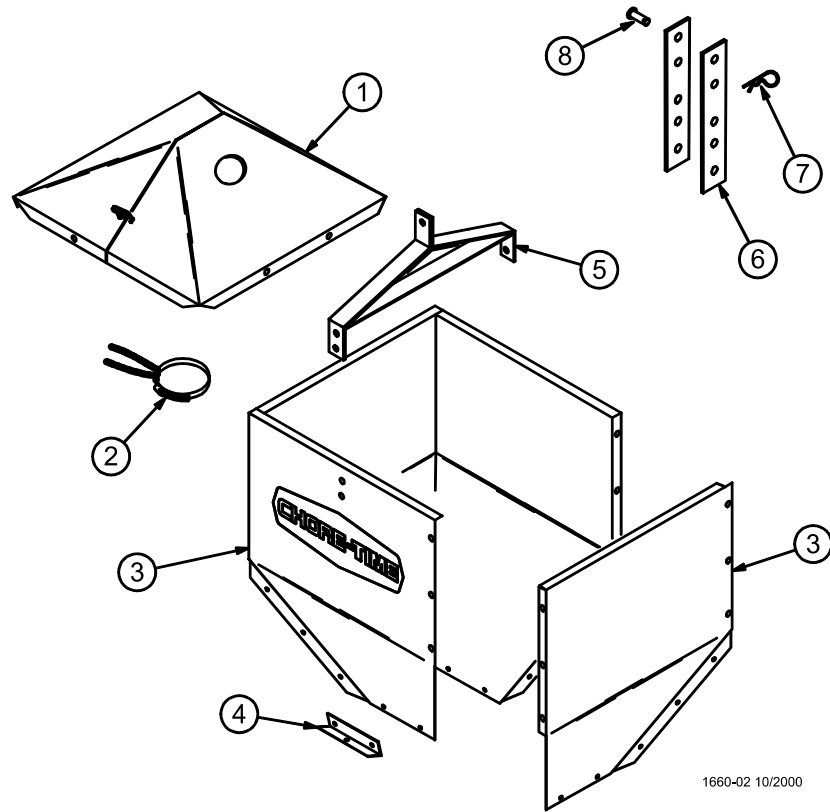

Item	Description	7941	28358
		Hopper Assembly	Hopper Ass'y with cover
		Part No.	
1	Hopper Cover	--	28206
2	Tube Support Assembly	14367	14367
3	Hopper Side	2680	2680
4	Boot Hanger	2671	2671
5	Hanger Bracket Assembly	2681	2681
6	Adjustment Bracket	2706	2706
7	Hair Pin	2664	2664
8	Clevis Pin, 5/16 x 1"	2797-1	2797-1

100 # Hopper Components

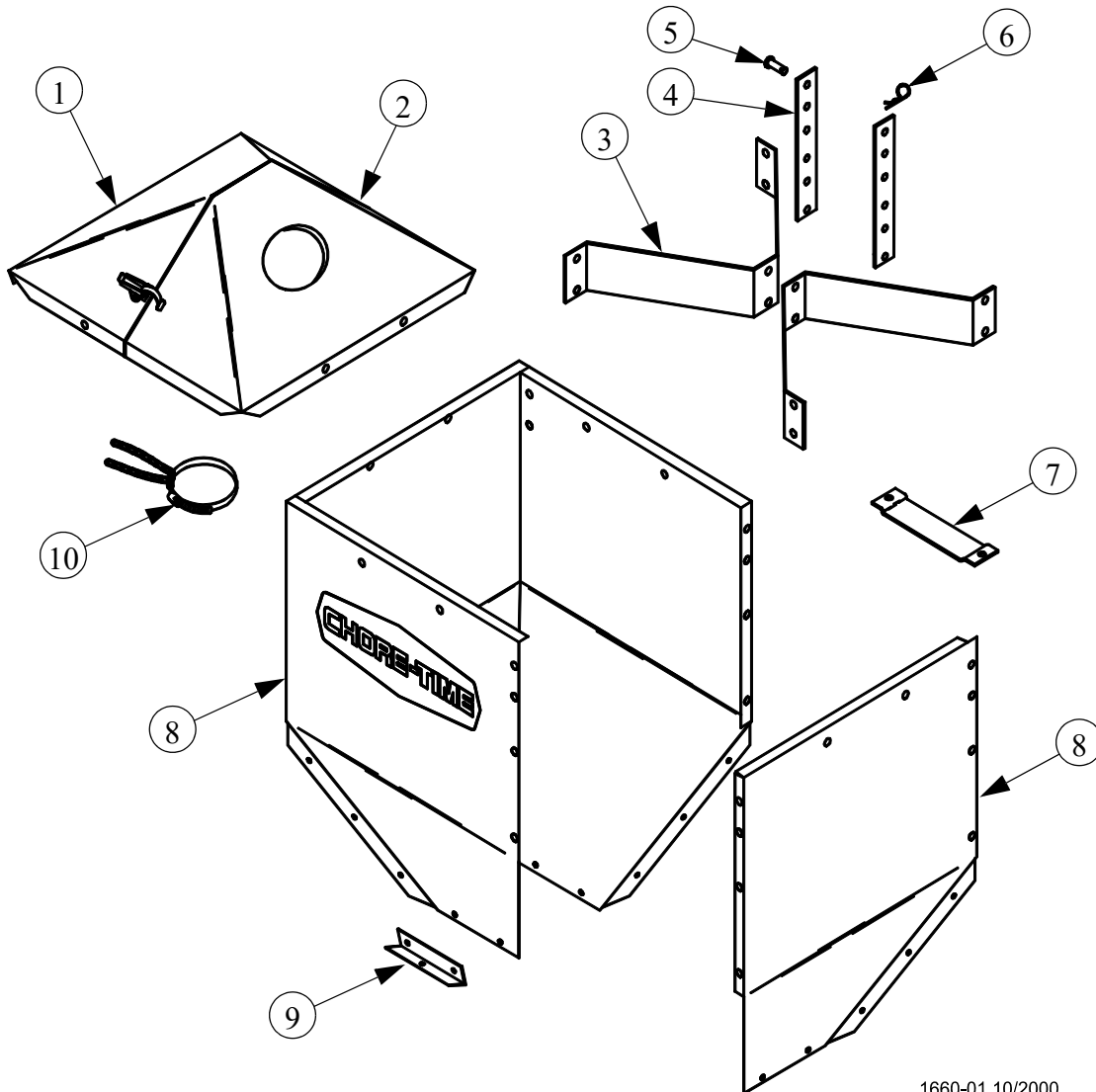

1660-01 10/2000

		28210 100 lb. Hopper Cover Ass'y.	28220 100 lb. Hopper Assembly (No Cover)	28240** 100 lb. Hopper & Cover Assembly
Key	Description	Part No.		
1	Hopper Cover (w/o hole)	28211	--	
2	Hopper Cover (w/ hole)	28212	--	
3	Hopper Hanger	--	28165	
4*	Adjustment Bracket	--	2706	
5*	Clevis Pin, 5/16" x 1"	--	2797-1	
6*	Hair Pin	--	2664	
7	H.L.C Mounting Bracket	--	28267	
8	Hopper Side (w/ hole)	--	28164	
9*	Boot Hanger	--	28168	
10*	Tube Support Assembly	--	14367	
--	100 lb. Hopper Cover Ass'y.	--	--	28210
--	100 lb. Hopper Ass'y	--	--	28220

*Included in parts package (part number 28167)

Hopper Mount Bracket

Part Number 49358 - Hopper Suspension Kit

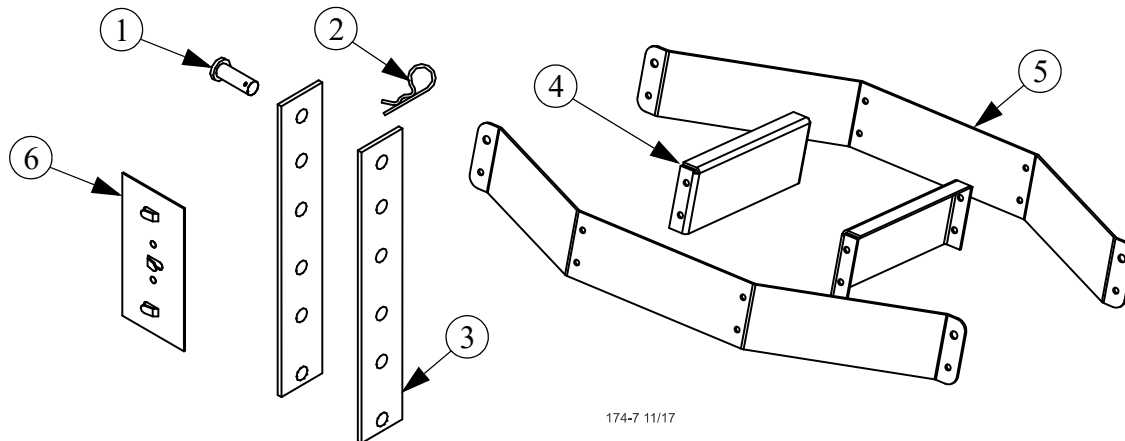

174-7 11/17

Item	Description	Part No. Single Boot Kit	Part No. Twin Boot Kit
1	Clevis Pin, 5/16" x 1"	2797-1	2797-1
2	Adjustment Bracket	2706	2706
3	Hair Pin	2664	2664
4	Suspension Brace	48680	48680
5	Suspension Angle	48679	48679
6	Cable Guide	34573	34573

Single Boot Components Part No. 6822

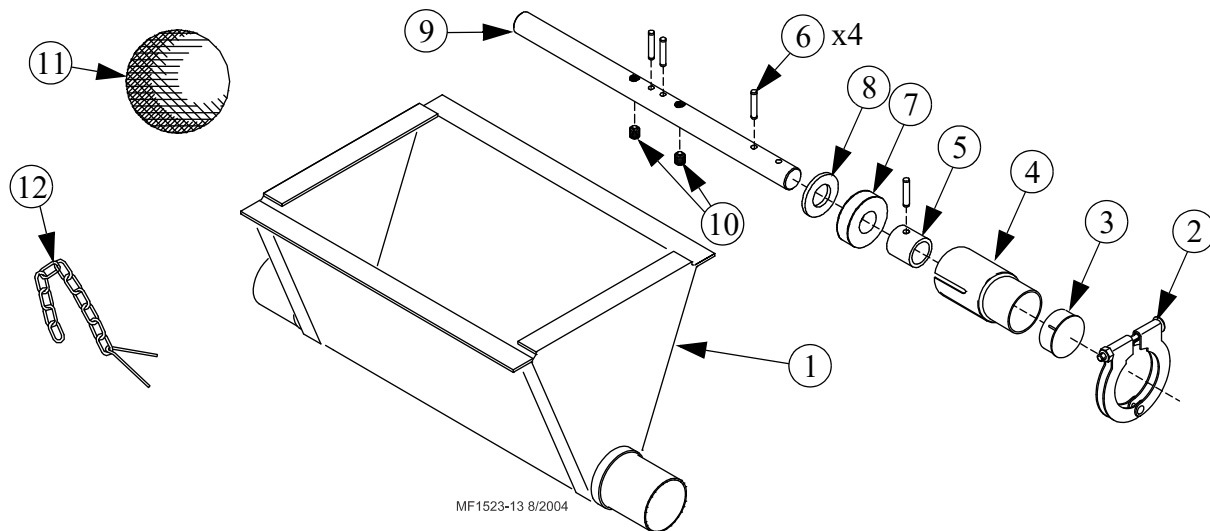

MF1523-13 8/2004

Item	Description	Part No.
1	Boot Weldment	3760
2	Tube Clamp	24063
3	Cap	29373
4	Outlet Tube	4556
5*	Sleeve	5648
6*	3/16 x 1" Pin	2960-1
7*	Bearing	2689
8*	Washer	2955-14

Item	Description	Part No.
9*	Anchor	38540
10*	Setscrew	47867
11	Cannonball	3531
12*	Latch Pin Ass'y	2683
--	Danger Decal	2527-9

*These parts included in p/n 39372 Anchor and Bearing Assembly

Twin Boot Components Part No. 6824

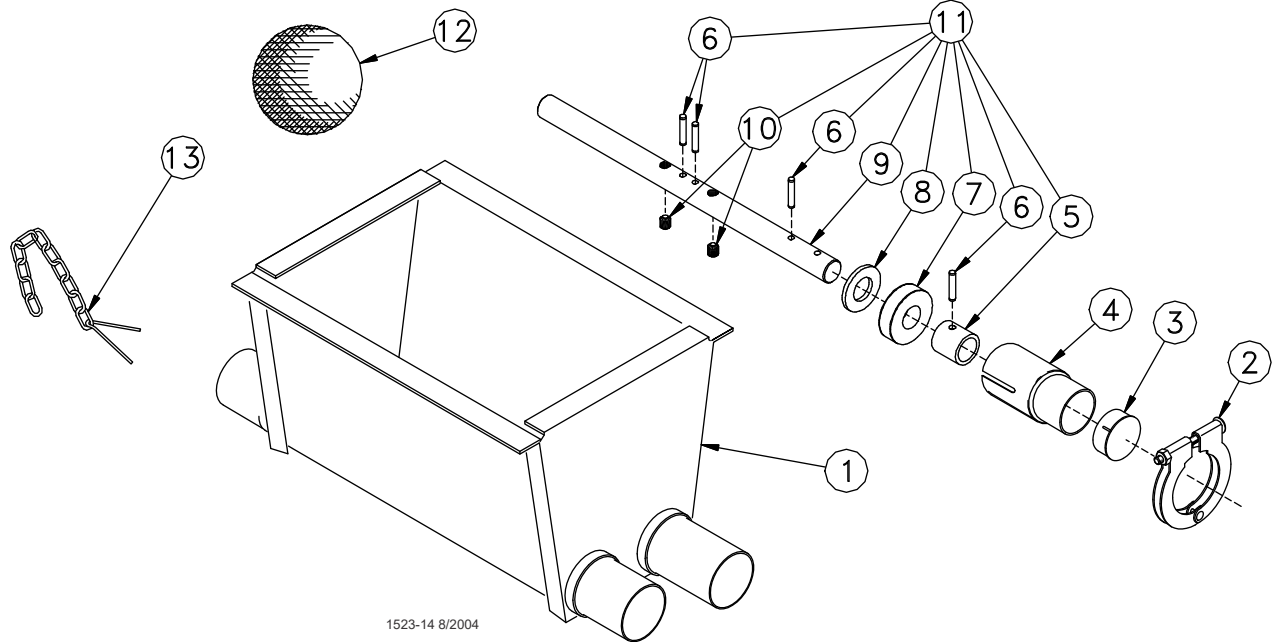

1523-14 8/2004

Item	Description	Part No.
1	Boot Weldment	3760
2	Tube Clamp	24063
3	Cap	29373
4	Outlet Tube	4556
5	Sleeve	5648
6	3/16 x 1" Pin	2960-1
7	Bearing	2689
8	Washer	2955-14

Item	Description	Part No.
9	Anchor	38540
10	5/16-18x7/8" Sock Hd Screw	47867
11	Anchor and Bearing Ass'y	39372
12	Cannonball	3531
13	Latch Pin Assembly	2683
--*	Jumper Wire Kit	5960
--	Danger Decal	2527-9

*The Jumper Wire Kit includes an insulated piece of High-Voltage Wire (part no. 28994) and (2) cable clamps.

Feeder Line Components

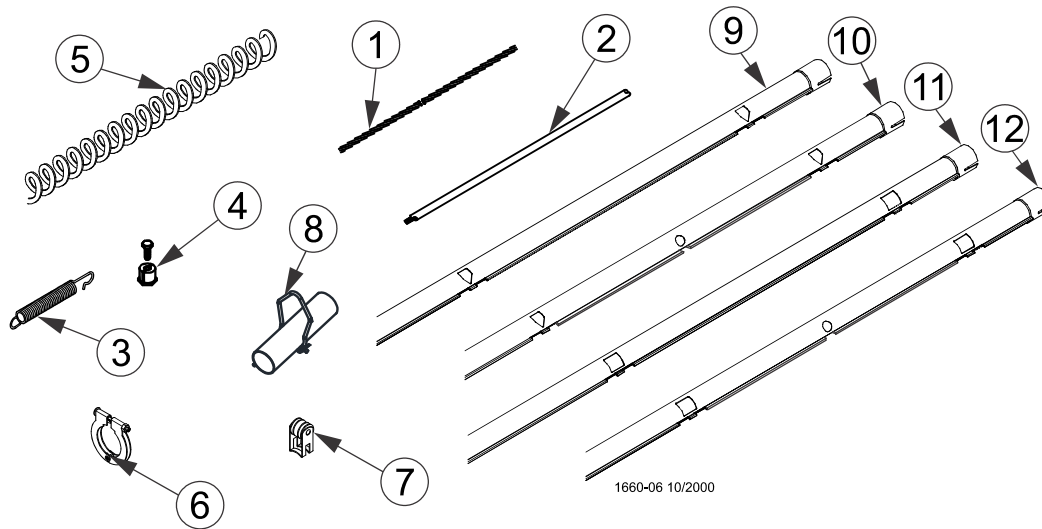

Item	Description	Part No.
1	1/16" Cable	1922
2	Charger Wire (165') Charger Wire (330')	28994-165 28994-330
3	Spring	7551
4	1/16" Cable Clamp	1826
5*	Auger	6820-0
6	Tube Clamp	24063
7	Anti-Roost Bracket	24060
8	Hanger KIT	51763
9	Standard Feeder Tube-1 3/4" Roll Form 9', 4 Hole Tube 10', 3 Hole Tube 10', 4 Hole Tube 10', 6 Hole Tube 10', 5 Hole Tube 12', 3 Hole Tube 12', 4 Hole Tube 12', 5 Hole Tube	6854-1 6854-5 6854-4 6854-23 6854-24 6854-8 6854-7 6854-6
10	Standard Feeder Tube-1 3/4" with Chick Holes (EZ. Holes) 9', 4 Hole, 2 EZ Holes 9', 4 Hole, 4 EZ Holes 10', 4 Hole, 2 EZ Holes 10', 3 Hole, 3 EZ Holes 10', 4 Hole, 4 EZ Holes 12', 4 Hole, 4 EZ Holes 12', 5 Hole, 5 EZ Holes 12', 4 Hole, 2 EZ Holes 12', 5 Hole, 2 EZ Holes	55997-6 55997-1 55997-7 55997-5 55997-2 55997-3 55997-4 55997-8 55997-9
11	Control Feeder Tube-1 3/4" Roll Form 9', 4 Hole Tube 10', 4 Hole Tube 10', 3 Hole Tube 12', 3 Hole Tube 12', 4 Hole Tube 12', 5 Hole Tube	43006-1 43006-4 43006-5 43006-8 43006-7 43006-6
12	Control Feeder Tube-1 3/4" with Chick Holes (EZ. Holes) 9', 4 Hole, 4 EZ. Holes 10', 4 Hole, 4 EZ. Holes 12', 4 Hole, 4 EZ. Holes 12', 5 Hole, 5 EZ. Holes	43006-15 43006-16 43006-17 43006-18

*Round up to the nearest 10'. Auger lengths from 50' to 500'. Example: 6820-200 would be a 200' roll of 6820 Auger.

KONAVI® Pan Assemblies

Broiler Pans (Part No. 57492 & 57493)

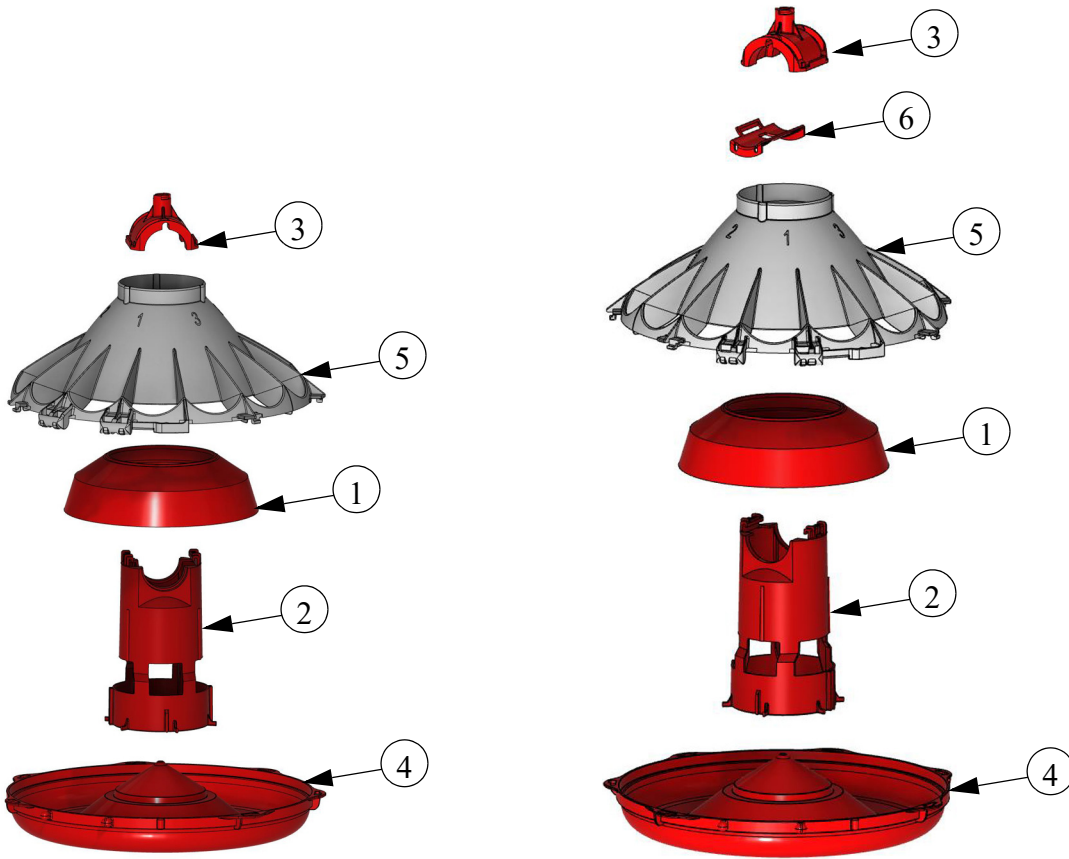

57492 Konavi® Broiler Pan

57493 Konavi® Broiler Pan w/Shutoff

Item	Description	57492	57493
		KONAVI® Broiler Pan	Konavi® Broiler Pan w/Shutoff
		Part No.	
1	Konavi Breeder Skirt	55816	55816
2	Konavi Feed Cone	55822	--
	Konavi Feed Cone w/Shutoff	--	55823
3	Konavi Two Piece Cap	55820	55820
4	Konavi Feeder Pan	57395	57395
5	Konavi Chic Excluder	57396	57396
6	Konavi Feed Cone Shutoff	--	55817

Colony Pan Assemblies (Part No. 57494 & 57495)

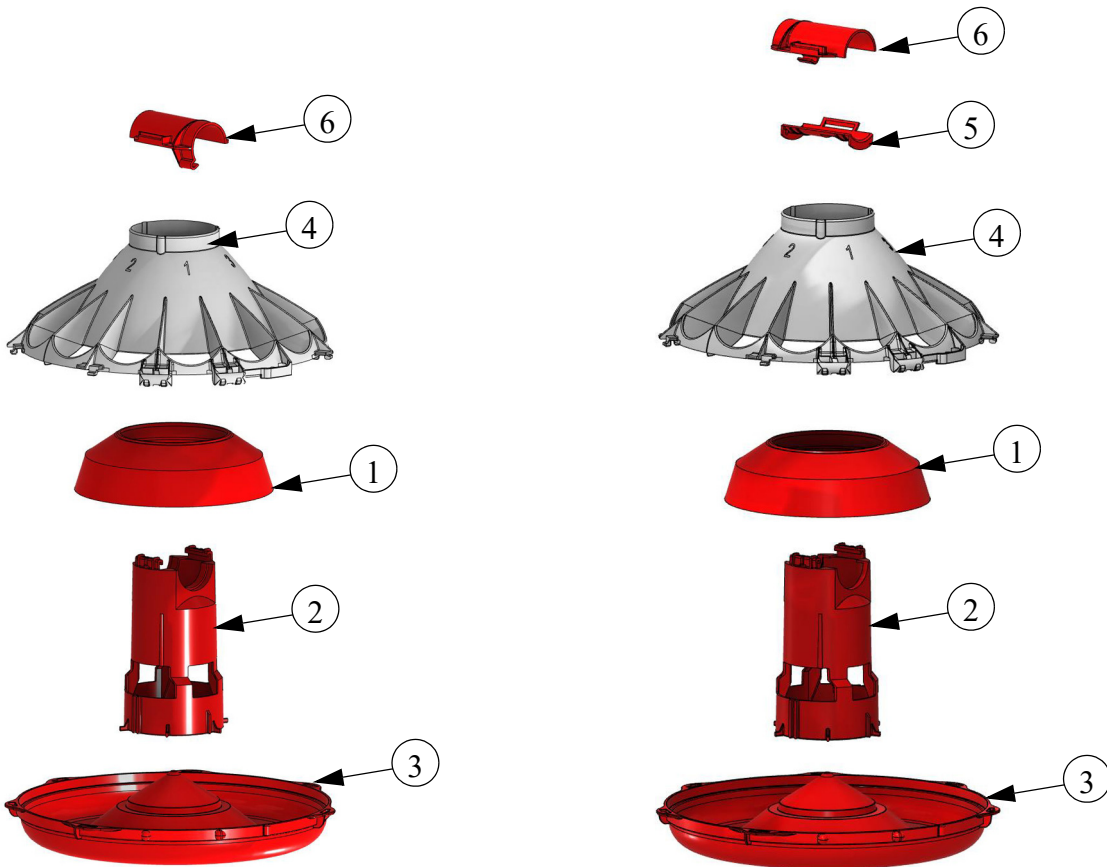

57494 Konavi® Colony Pan

57495 Konavi® Colony Pan w/Shutoff

Item	Description	57494	57495
		Konavi® Colony Pan	Konavi® Colony Pan w/ Slide Shutoff Part Number
1	Konavi Breeder Skirt	55816	55816
2	Konavi Feed Cone	55822	--
	Konavi Feed Cone w/Shutoff	--	55823
3	Konavi Feeder Pan	57395	57395
4	Konavi Chic Excluder	57396	57396
5	Konavi Feed Cone Shutoff	--	55817
6	Konavi Colony Cap	55824	55824

Power Unit Assemblies

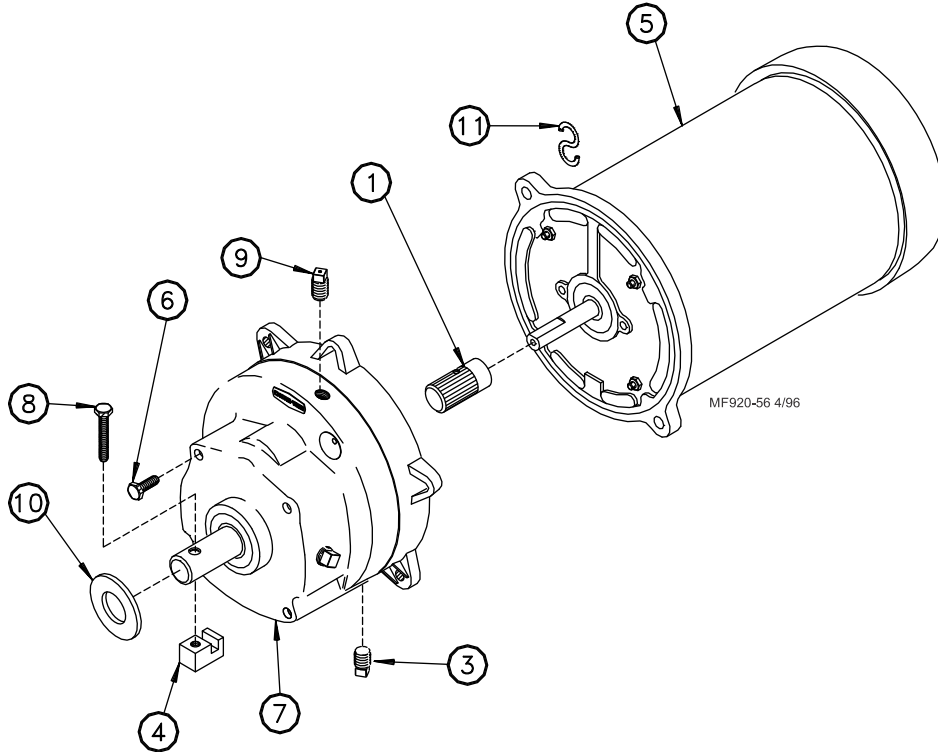

Item	Description	3259-84 Part No.	3259-85 Part No.	3259-98 Part No.	3259-100 Part No.	3259-128 Part No.
1	Pinion Assembly	5046	5046	5046	5046	5046
2	----	----	----	----	----	----
3	Pipe Plug (magnetic)	30160	30160	30160	30160	30160
4	Driver Block	4642	4642	4642	4642	4642
5	Motor	4229	5703	5977	28031	24624
6	5/16-18x5/8 Hex HD Screw	4412-1	4412-1	4412-1	4412-1	4412-1
7	Gearhead	3261-5	3261-5	3261-11	3261-11	3261-5
8	1/4-20x1-1/2 Socket Hd Screw	5083-8	5083-8	5083-8	5083-8	5083-8
9	Vent Plug	3516	3516	3516	3516	3516
10	Flat Washer	1484	1484	1484	1484	1484
11	"S" Hook	2805	2805	2805	2805	2805
--	Cord Assembly	----	----	28028	----	----
--	Connector (Romex)	----	----	----	----	----
--	Connector (90 Degree)	----	----	4228	----	----

Power Unit Assembly Part Numbers

Part No.	HP	RPM	Phase	Hz	Voltage	Usages
3259-84	1/3 HP	348 RPM	Single Phase	60 Hz	230	
3259-85	1/2 HP	348 RPM	Single Phase	60 Hz	230	
3259-98	1/2 HP	348 RPM	Single Phase	50 Hz	230	Use with all Control Units
3259-100	1/2 HP	348 RPM	Three Phase	50 Hz	220/380	Use with all Control Units
3259-128	1/2 HP	348 RPM	Three Phase	60 Hz	230	Use with all Control Units

This page left blank intentionally.....

KONAVI® Mechanical End Control 57697

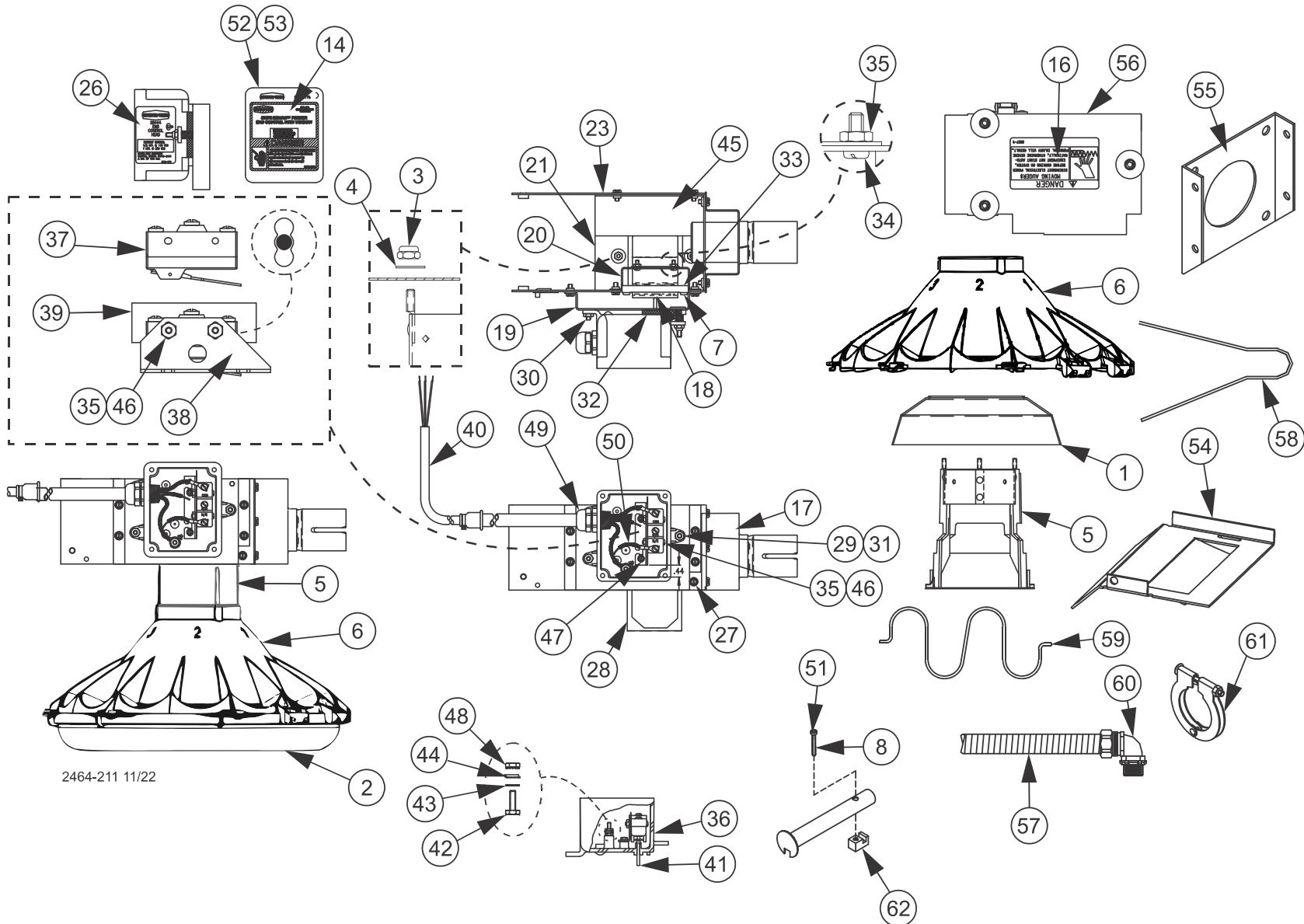

Item	Part No.	Description
1	55816	Feed Cone Skirt
2	57395	KONAVI® Feeder Pan
3	34019	10-24 Lock Nut
4	6723	Flat Washer
5	56078	Machined Inner Cone
6	57396	Chick Excluder
7	34660	6-32 Phil. Pan Hd. Screw
8	5083-8	Socket Head Screw
14	2529-1180	End Control Decal
16	2527-9	Danger Decal
17	24683	Support Bracket
18	56076	Paddle
19	25084	Switch Box Mount
20	25433	Stop Panel
21	40749	Switch Bracket
23	14434	Control Body
26	2529-249	Control Decal
27	4416-7	10-24 x .375 Hx. WH. Screw
28	25318	Mylar Assembly
29	6963	10-32 Lock Nut
30	4297	10-32 Hx. Nut
31	6972	Spring
32	6968-1	Gasket
33	25045	Paddle Retainer
34	4402-3	6-32 Screw
35	771	6-32 Nut
36	24702	Switch Box
37	46091	Actuator Switch

Item	Part No.	Description
38	46122	Switch Bracket
39	1907-5	Switch Insulation
40	25495	Control Cord Assembly
41	8757	1/8 Round Head Rivet
42	7007	10-32 Stud
43	305	Lock Washer
44	5775	Cup Washer
45	41363	Panel Deflector
46	1921	6-32 Screw
47	46011	6 x 3/8 Screw
48	40851	10-32 Keps Nut
49	24685	1/2 Water Tight Connector
50	25499W	Wire Assembly
51	44794	Drive Tube Weldment
52	6777	Switch Box Gasket
53	6776	Switch Box Cover
54	14432	Bottom Cover
55	4188	Anchor Plate
56	24682	Control Assembly Cover
57	26982-1	14" Flexible Conduit
58	2798	Anti-Roost Guard
59	48511	Spring Lock
60*	23810	90° 1/2" Liquid Tight Connector
61*	24062	Tube Clamp
62*	4642	Drive Block
*These parts included in 40809 Parts Package		

KONAVI® Proximity Sensor End Control 57698

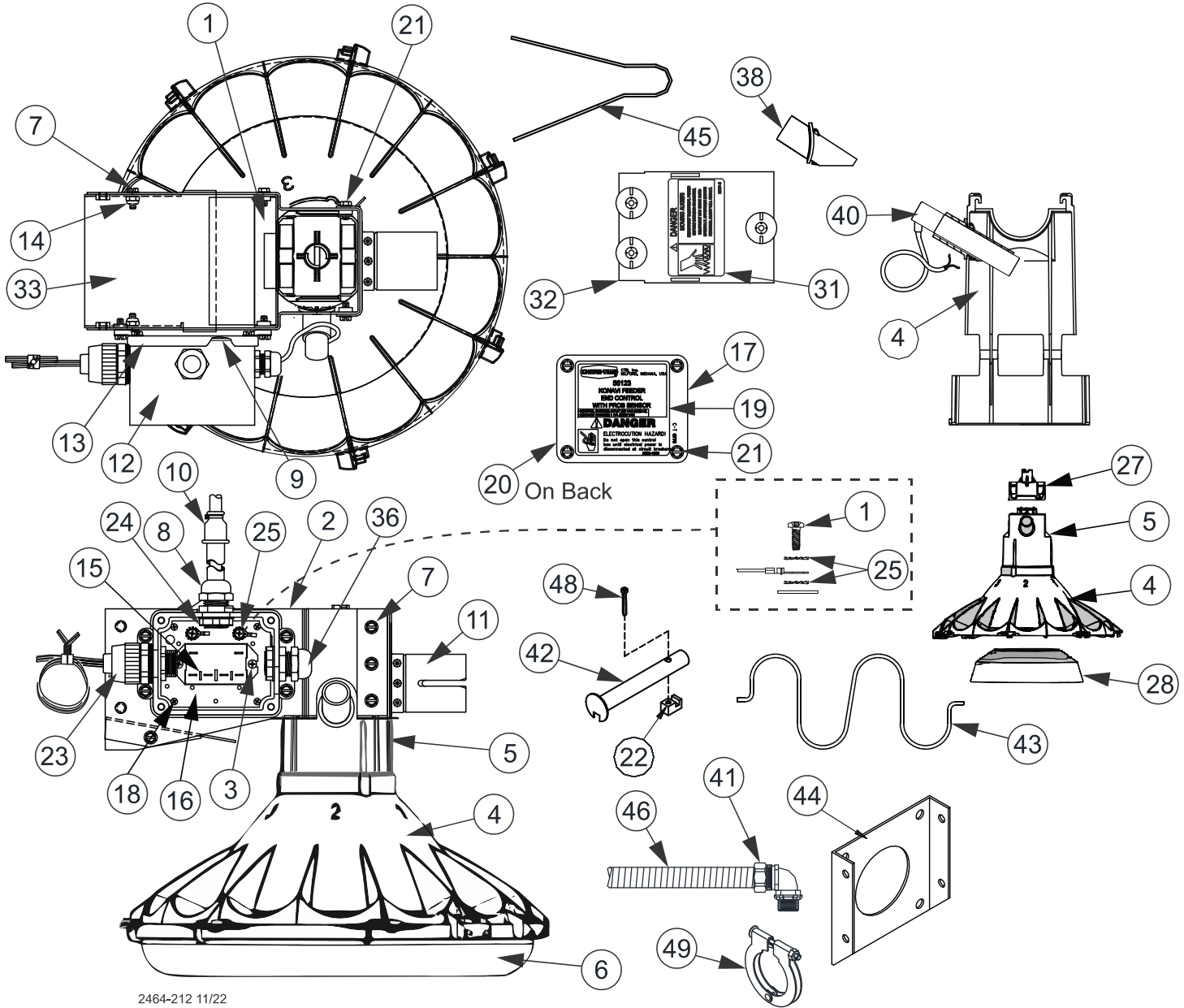

2464-212 11/22

Item	Part No.	Description	Item	Part No.	Description
1	48081	Bracket Support	24	43662	.50 Conduit Lock Nut
2	56126	Control Body Sensor	25	305	#10 Ext. Lock Washer
3	34660	6-32 x .375 SFTP Screw	26	23779	Liquid Tight Connector
4	57396	Chick Excluder	27	55820	KONAVI® Two Piece Top
5	56125	Machined Support Cone	28	55816	Feed Cone Skirt
6	57395	KONAVI® Feeder Pan	31	2527-9	Danger Decal
7	4416-7	10-24 Hex Screw	32	48491	Top Cover w/Insulators
8	24685	Water Tight Connector	33	48086	End Control Bottom Cover
9	6777	Switch Box Gasket	38	56084	Sensor Switch Holder
10	4999-116	Cord Assembly	40	56275	Proximity Sensor
11	56083	Tube Weldment	41*	3357	.50 Conduit Lock Nut
12	42627-12	General Purpose Box	42	44794	Drive Tube Weldment
13	6956	Box Mounting Cover	43	48511	Spring Lock
14	34019	10-24 Nylon Hx Lock Nut	44	4188	Anchor Plate
15	28904	Relay	45	2798	Anti-Roost Guard
16	52316-2	Control Panel Relay Mount	46	26981	Flex Conduit
17	6776	Terminal Box Cover	47*	23810	90° Water Tight Connector
18	35493	4-24 x /375 Phil PH Screw	48	5083-8	Socket Head Screw
19	2529-1181	End Control Decal	49*	24062	1.75" Tube Clamp
20	2526-377	Date of Manufacture Decal	*These parts included in 43233 Parts Package		
21	28075	#10 x .5 Screw			
22	4642	Drive Block			
23	26980	Liquid Tight Fitting			

KONAVI® 57699 Proximity Sensor Mid Line Control

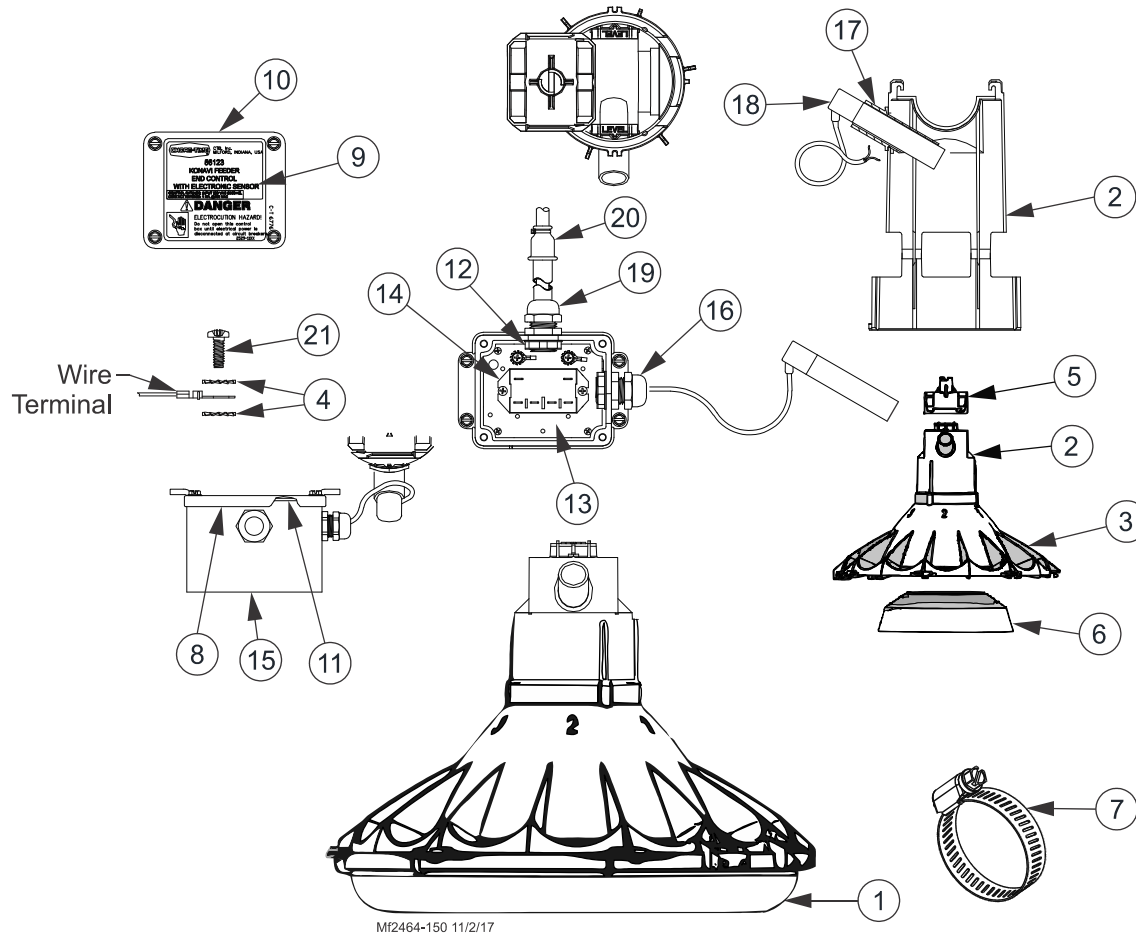

MF2464-150 11/2/17

Item	Part No.	Description
1	57395	KONAVI® Feeder Pan
2	56125	KONAVI® Machined Cone
3	57396	KONAVI® Chick Excluder
4	305	Ext. Lock Washer
5	55820	KONAVI® Two Piece Top
6	55816	KONAVI® Feeder Skirt
7	3527	1.875 Hose Clamp
8	6956	Terminal Cover
9	2529-1187	Control Decal
10	6776	Terminal Box Cover
11	6777	Switch Box Gasket
12	43662	.50 Conduit Lock Nut
13	52316-2	Control Panel Relay Mount
14	28904	Relay
15	42627-12	General Purpose Box
16	13477	Small Water Tight
17	56084	Switch Holder
18	56275	Proximity Sensor
19	24685	1/2" Watertight Connector
20	23779	Liquid Tight Connector
21	34660	6-32 x 3/8 Phil. Pan. Hd. Screw

KONAVI® MECHANICAL MID LINE CONTROL 57700

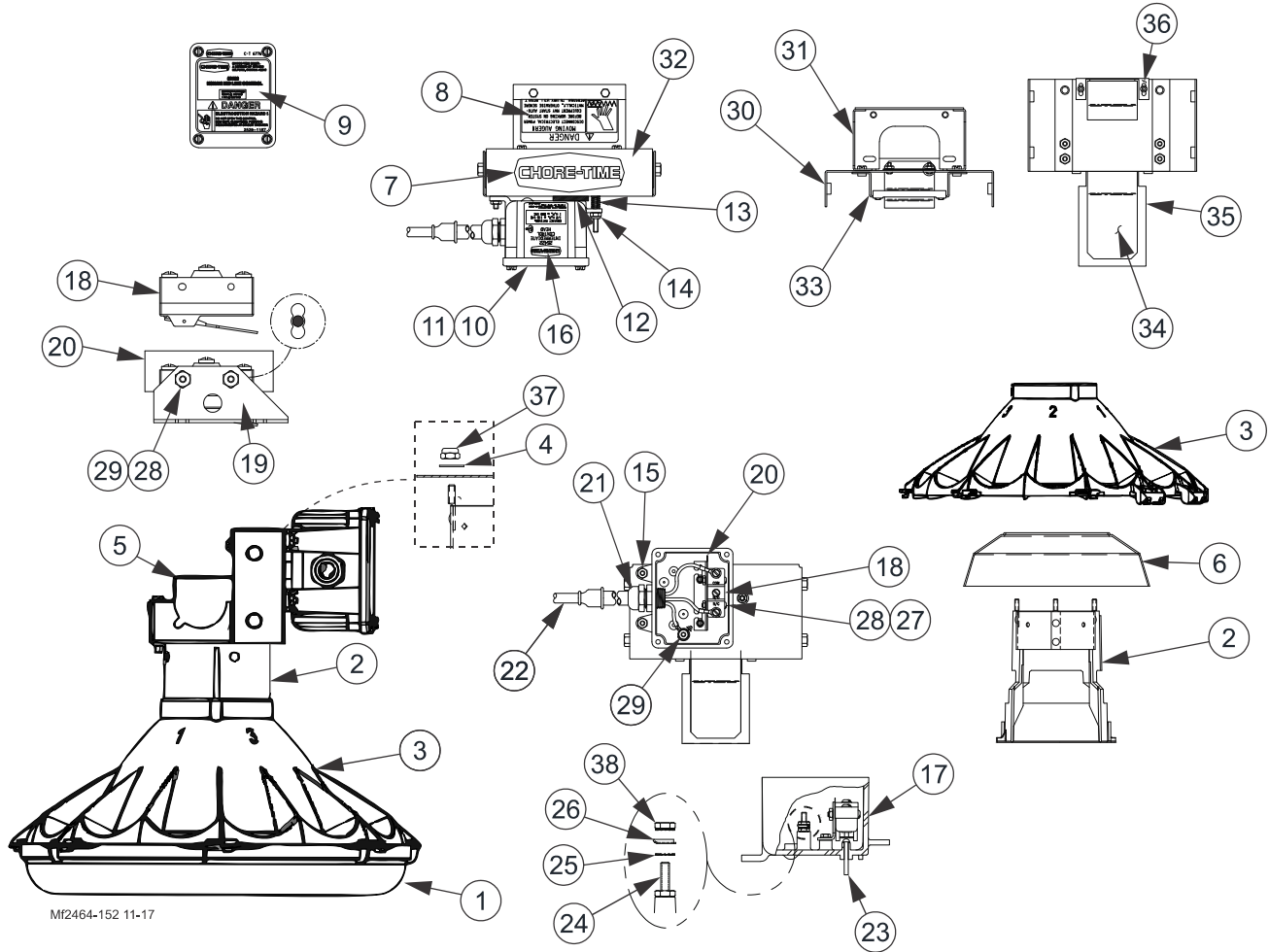

MF2464-152 11-17

Item	Part No.	Description
1	57395	KONAVI® Feeder Pan
2	56078	KONAVI® Support Cone Assembly
3	57396	KONAVI® Chick Excluder
4	6723	#10 Flat Washer
5	14756	Retainer Tube
6	55816	KONAVI® Feeder Skirt
7	2525-2	CT Decal
8	2527-9	Danger Decal
9	2529-1187	Control Decal
10	6776	Switch Box Cover
11	6777	Switch Box Gasket
12	6968-1	Gasket
13	6972	Spring
14	6963	10-32 Lock Nut
15	4297	10-32 Hex Nut
16	2529-248	Control Decal
17	34842	Switch Box
18	46091	Actuator Switch
19	46122	Switch Bracket
20	1907-5	Switch Insulation
21	34685	1/2" Water Tight Connector

Item	Part No.	Description
22	4999-49	Cord Assembly
23	8757	1/8 x 1 Rivet
24	7007	10-32 Stud
25	305	Lock Washer
26	5775	Cup Washer
27	1921	6-32 x .875 Screw
28	771	6-32 Nut
29	46011	6-20 x .375 Screw
30	25046	Front Panel
31	41364	Tube Support
32	25047	Back Cover
33	25048	Switch Box Mount
34	56076	KONAVI® Paddle
35	25318	Mylar Assembly
36	25045	Paddle Retainer
37	34019	10-24 Lock Nut
38	40851	10-32 KEP Nut

Winch (Part No. 47687)

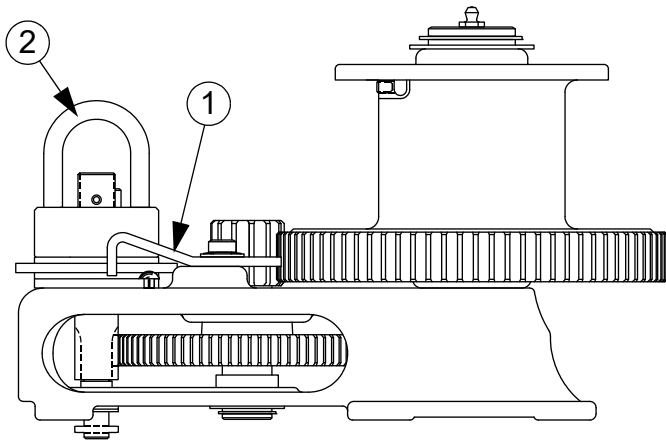

Item	Qty.	Description	Part No.
1	1	Pawl	47687-5
2	1	Input Shaft Assembly	47687-1

Miscellaneous Suspension Components

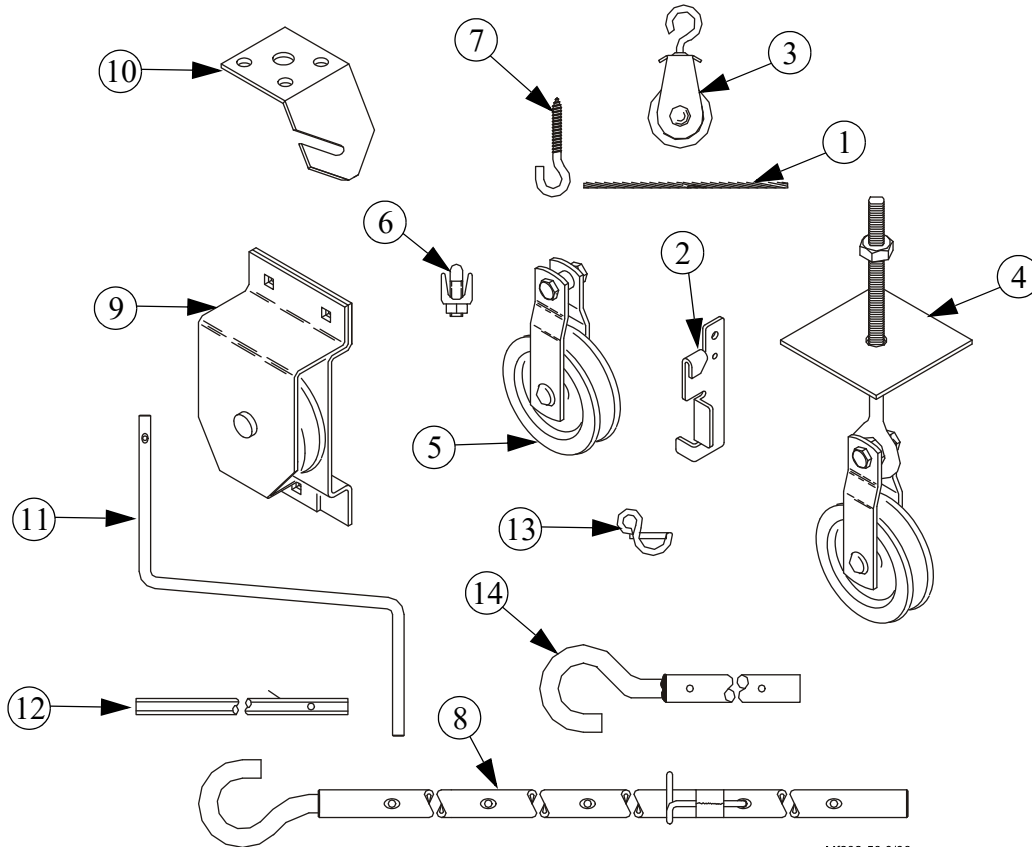

MF232-58 9/96

<u>Item</u>	<u>Description</u>	<u>Part No.</u>
1	3/16 Cable	1213
2	Cable Lock	14337
3	Pulley with Swivel	3004
4	Heavy Duty Pulley Assembly	2014
5	Pulley	2500
6	3/16" Cable Clamp	732
7	ATF Screw Hook	2041
8	Extendable drive tube	47637
9	Pulley Assembly	28429
10	Ceiling Hook	28550
11	Handle Shank	3148
12	Drill Adapter Shaft	2886
13	Winch Handle Pin	3761
14	Winch Drive Tube (4')	2884-1
	Winch Drive Tube (8')	2884-2
	Winch Drive Tube (2')	2884-4
--	Full Line Suspension Kit	7948

Item 11 and Item 13 may be ordered as a kit under Part No. 2885.

Item 12 and Item 13 may be ordered as a kit under Part No. 2886

Item 11, 13 and 8 may be ordered as a kit under Part No. 47638.

Item 10 and Item 12 may be ordered as a kit under part no. 2885.

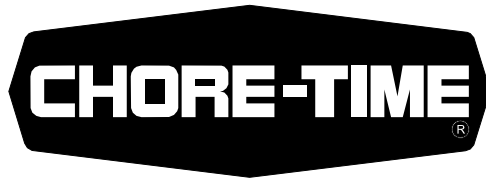

MADE TO WORK.

BUILT TO LAST.®

Revisions to this Manual

Page No.	Description of Change	ECO
64	Was 2883 Winch	35577

**For additional parts and information, contact your nearest Chore-Time distributor or representative.
Find your nearest distributor at: www.choretime.com/contacts**

CTB, Inc.
PO Box 2000
Milford, Indiana 46542-2000 USA
Phone (574) 658-4101 Fax (877) 730-8825
Email: choretime@choretime.com
Internet: www.choretime.com