

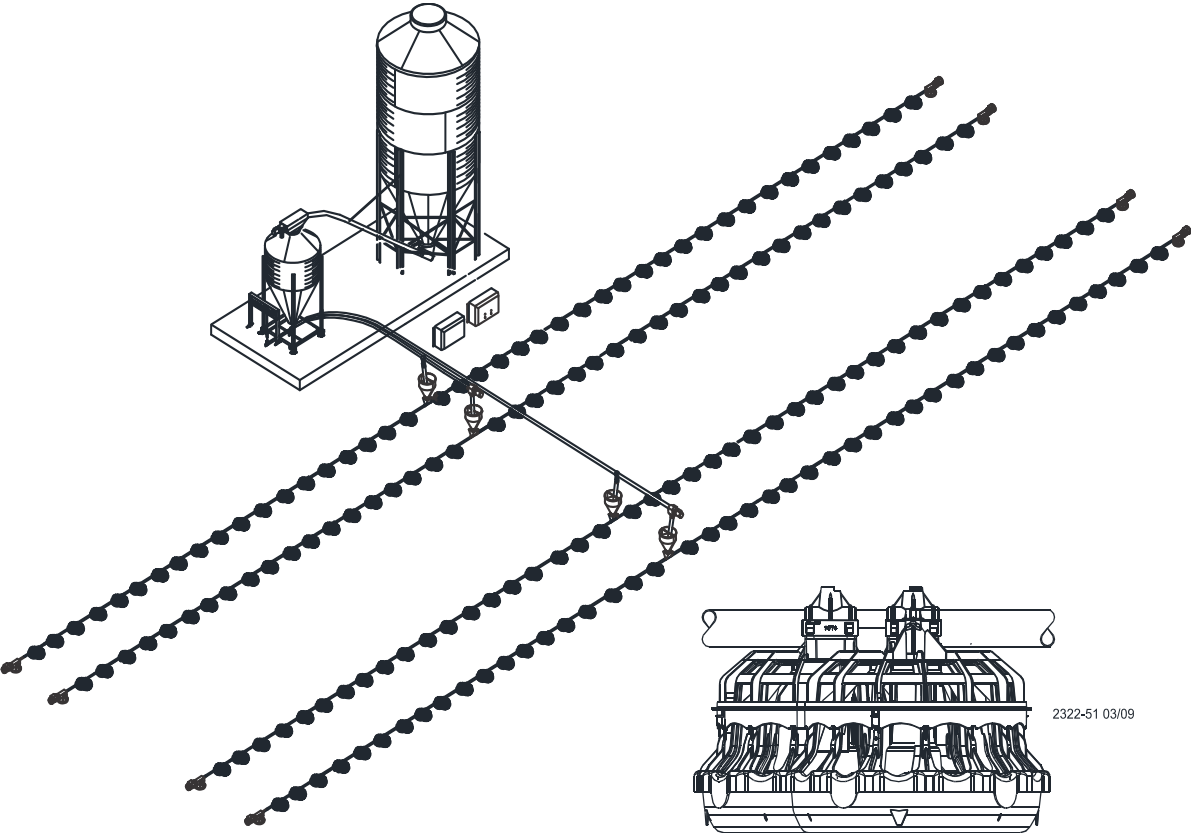


Installation and Operators Manual

Installation and Operators Manual

# GENESIS® STRAIGHT-LINE FEEDING SYSTEM

## Installation and Operation Manual



## Chore-Time Limited Warranty

CTB, Inc. (“Chore-Time”) warrants the new CHORE-TIME products manufactured by Chore-Time to be free from defects in material or workmanship under normal usage and conditions, for One (1) year from the date of installation by the original purchaser (“Warranty”). Chore-Time provides for an extension of the aforementioned Warranty period (“Extended Warranty Period”) with respect to certain Product parts (“Component Part”) as set forth in the table below. If such a defect is determined by Chore-Time to exist within the applicable period, Chore-Time will, at its option, (a) repair the Product or Component Part free of charge, F.O.B. the factory of manufacture or (b) replace the Product or Component Part free of charge, F.O.B. the factory of manufacture. This Warranty is not transferable, and applies only to the original purchaser of the Product.

Component Part	Extended Warranty Period
RXL Fan (except motors and bearings)	Three (3) Years
TURBO® Fan (except motors and bearings)	Three (3) Years
TURBO® Fan fiberglass housing, polyethylene cone, and cast aluminum blade.	Lifetime of Product
TURBO® fan motor and bearings.	Two (2) Years
Chore-Time® Poultry Feeder Pan	Three (3) Years
Chore-Time® Rotating Centerless Augers (except where used in applications involving high moisture feed stuffs exceeding 17%)	Ten (10) Years
Chore-Time Steel Auger Tubes	Ten (10) Years
ULTRAFLO® Breeder Feeding System auger and feed trough.	Five (5) Years
ULTRAPAN® Feeding System augers .	Five (5) Years

### CONDITIONS AND LIMITATIONS

THIS WARRANTY CONSTITUTES CHORE-TIME’S ENTIRE AND SOLE WARRANTY AND CHORE-TIME EXPRESSLY DISCLAIMS ANY AND ALL OTHER WARRANTIES, INCLUDING, BUT NOT LIMITED TO, EXPRESS AND IMPLIED WARRANTIES, INCLUDING, WITHOUT LIMITATION, WARRANTIES AS TO MERCHANTABILITY OR FITNESS FOR PARTICULAR PURPOSES. CHORE-TIME shall not be liable for any direct, indirect, incidental, consequential or special damages which any purchaser may suffer or claim to suffer as a result of any defect in the Product. Consequential or Special Damages as used herein include, but are not limited to, lost or damaged products or goods, costs of transportation, lost sales, lost orders, lost income, increased overhead, labor and incidental costs, and operational inefficiencies. *Some jurisdictions prohibit limitations on implied warranties and/or the exclusion or limitation of such damages, so these limitations and exclusions may not apply to you. This warranty gives the original purchaser specific legal rights. You may also have other rights based upon your specific jurisdiction.*

Compliance with federal, state and local rules which apply to the location, installation and use of the Product are the responsibility of the original purchaser, and CHORE-TIME shall not be liable for any damages which may result from non-compliance with such rules.

The following circumstances shall render this Warranty void:

- Modifications made to the Product not specifically delineated in the Product manual.
- Product not installed and/or operated in accordance with the instructions published by the CHORE-TIME.
- All components of the Product are not original equipment supplied by CHORE-TIME.
- Product was not purchased from and/or installed by a CHORE-TIME authorized distributor or certified representative.
- Product experienced malfunction or failure resulting from misuse, abuse, mismanagement, negligence, alteration, accident, or lack of proper maintenance, or from lightning strikes, electrical power surges or interruption of electricity.
- Product experienced corrosion, material deterioration and/or equipment malfunction caused by or consistent with the application of chemicals, minerals, sediments or other foreign elements.
- Product was used for any purpose other than for the care of poultry and livestock.

The Warranty and Extended Warranty may only be modified in writing by an officer of CHORE-TIME. CHORE-TIME shall have no obligation or responsibility for any representations or warranties made by or on behalf of any distributor, dealer, agent or certified representative.

Effective: **April, 2014**

CTB, Inc.  
 PO Box 2000  
 Milford, Indiana 46542-2000 USA  
 Phone (574) 658-4101  
 Email: [choretime@choretime.com](mailto:choretime@choretime.com)  
 Internet: [www.choretime.com](http://www.choretime.com)

# Contents

Topic	Page
<b>Chore-Time Limited Warranty</b> .....	<b>2</b>
<b>About This Manual</b> .....	<b>5</b>
<b>Safety Information</b> .....	<b>5</b>
<b>Safety Instructions</b> .....	<b>6</b>
Follow Safety Instructions.....	6
Decal Descriptions.....	6
DANGER: Moving Auger.....	6
DANGER: Electrical Hazard.....	6
CAUTION:.....	6
<b>General</b> .....	<b>6</b>
Support Information.....	6
Manufacturer's Recommendations: Birds per Pan.....	7
<b>Planning the System</b> .....	<b>8</b>
Planning your fill system:.....	9
<b>General Installation Information</b> .....	<b>10</b>
Capacities and specifications.....	10
<b>Laying out the Suspension System</b> .....	<b>10</b>
<b>Installing the Suspension System</b> .....	<b>11</b>
Power Lift Winch Installation.....	11
Installing the Main Winch Cable.....	12
Screw Hook Installation.....	13
Ceiling Hook Installation.....	14
Drop Installation.....	14
<b>Breeder Hen Feeder Pan Assembly</b> .....	<b>15</b>
Feed Pan Assembly Box Construction.....	16
Breeder Pan Assembly Procedure.....	17
Feeder Pan and Tube Assembly Fixture Construction.....	19
Feeder Pan and Tube Installation Procedure.....	20
<b>Breeder Pullet Feeder Pan Assembly</b> .....	<b>23</b>
Feed Pan Assembly Box Construction.....	24
Pullet Pan Assembly Procedure.....	25
Feeder Pan and Tube Assembly Fixture Construction.....	26
Pullet Pan and Tube Installation Procedure.....	27
<b>Assemble and Suspend the Feeder Line</b> .....	<b>29</b>
<b>Anti-Roost Installation</b> .....	<b>31</b>
<b>End Control Installation</b> .....	<b>33</b>
Auger Installation.....	34
<b>Mid-Line Control Installation</b> .....	<b>37</b>
<b>Feeder Management</b> .....	<b>39</b>
Initial Start-up of the GENESIS® Straight-Line Feeding System.....	39
Feeding controls.....	39
Start up operation.....	39
General Operation of the GENESIS® Straight-Line Feeding system.....	39
The GENESIS® Straight-Line Pullet Feeder.....	40

# Contents - continued

Topic	Page
The GENESIS® Straight-Line Breeder Feeder . . . . .	40
Feeder height and feed level . . . . .	40
Feeder Height Adjustment. . . . .	41
Electro-guard Operation. . . . .	41
<b>Maintenance . . . . .</b>	<b>42</b>
Gear Head Maintenance. . . . .	42
Mechanical Switch Adjustment Procedure . . . . .	42
Feeder Line . . . . .	43
Power Lift Winch Maintenance. . . . .	43
<b>Wiring . . . . .</b>	<b>44</b>
Wiring Notes . . . . .	44
GENESIS® Feeder with 34380 BREEDER CONTROL . . . . .	45
GENESIS® Feeder with CHORE-TRONICS® Control. . . . .	46
GENESIS® Feeder with CHORE-TRONICS® Control. . . . .	47
Adding Channel 3 and 4 to 34380 Breeder Box . . . . .	48
Adding MID LINE Control to Pullet Feeder . . . . .	48
<b>Parts List . . . . .</b>	<b>49</b>
150# Plastic Hopper . . . . .	49
Hopper Boot Suspension Bracket (optional) . . . . .	50
Single Boot Components Part No. 6822 . . . . .	51
Twin Boot Components Part No. 6824 . . . . .	52
Feeder Line Components . . . . .	53
Poultry Trainer and Line Charger . . . . .	54
Power Unit Assembly . . . . .	55
End Control Part No. 54336. . . . .	56
MODEL C2® PLUS Shallow Mid-line Control (42013) . . . . .	58
GENESIS® Feeder Pan Assemblies . . . . .	60
Feeder Assembly Tools . . . . .	61
Feeder Line Suspension . . . . .	62
Power Winch (Part No. 47687) . . . . .	63
MODEL C2® PLUS Adjustable Grill. . . . .	63
<b>Trouble Shooting the Floor Feeding System . . . . .</b>	<b>64</b>

## About This Manual

The intent of this manual is to help you in two ways. One is to follow step-by-step in the order of assembly of your product. The other way is for easy reference if you have questions in a particular area.

**Important: Read ALL instructions carefully before starting construction.**

**Important: Pay particular attention to all SAFETY information.**

- *Metric measurements are shown in millimeters and in brackets, unless otherwise specified. “ ” equals inches and “ ’ ” equals feet in English measurements.*

*Examples:*

*1" [25.4]*

*4' [1 219]*

- Optional equipment contains necessary instructions for assembly or operation.
- Very small numbers near an illustration (*i.e.*, 1257-48) are identification of the graphic, not a part number.

Note: The original, authoritative version of this manual is the English version produced by CTB, Inc. or any of its subsidiaries or divisions, (hereafter collectively referred to as "CTB"). Subsequent changes to any manual made by any third party have not been reviewed nor authenticated by CTB. Such changes may include, but are not limited to, translation into languages other than English, and additions to or deletions from the original content. CTB disclaims responsibility for any and all damages, injuries, warranty claims and/or any other claims associated with such changes, inasmuch as such changes result in content that is different from the authoritative CTB-published English version of the manual. For current product installation and operation information, please contact the customer service and/or technical service departments of the appropriate CTB subsidiary or division. Should you observe any questionable content in any manual, please notify CTB immediately in writing to: CTB Legal Department, P.O. Box 2000, Milford, IN 46542-2000 USA.

## Safety Information

**Caution, Warning and Danger Decals** have been placed on the equipment to warn of potentially dangerous situations. Care should be taken to keep this information intact and easy to read at all times. Replace missing or damaged safety decals immediately.

Using the equipment for purposes other than specified in this manual may cause personal injury and/or damage to the equipment.

### Safety–Alert Symbol



**This is a safety–alert symbol.** When you see this symbol on your equipment, be alert to the potential for personal injury. This equipment is designed to be installed and operated as safely as possible...however, hazards do exist.

### Understanding Signal Words

**Signal words** are used in conjunction with the safety–alert symbol to identify the severity of the warning.



**DANGER** indicates an imminently hazardous situation which, if not avoided, **WILL** result in death or serious injury.



**WARNING** indicates a potentially hazardous situation which, if not avoided, **COULD** result in death or serious injury.



**CAUTION** indicates a hazardous situation which, if not avoided, **MAY** result in minor or moderate injury.

## Safety Instructions

### Follow Safety Instructions

Carefully read all safety messages in this manual and on your equipment safety signs. Follow recommended precautions and safe operating practices.

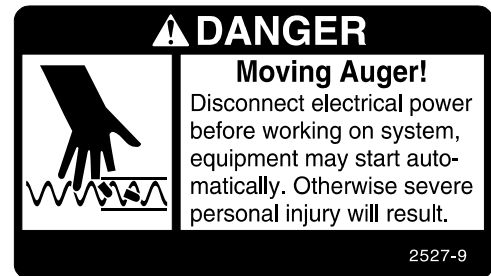
Keep safety signs in good condition. Replace missing or damaged safety signs.

### Decal Descriptions

#### **DANGER: Moving Auger**

This decal is placed on the Panel Weldment.

Severe personal injury will result, if the electrical power is not disconnected, prior to servicing the equipment.



#### **DANGER: Electrical Hazard**

Disconnect electrical power before inspecting or servicing equipment unless maintenance instructions specifically state otherwise.

Ground all electrical equipment for safety.

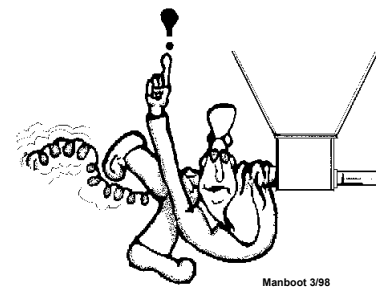
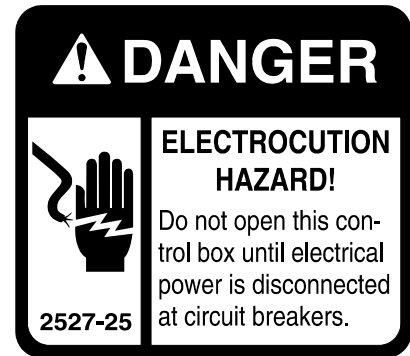
All electrical wiring must be done by a qualified electrician in accordance with local and national electric codes.

Ground all non-current carrying metal parts to guard against electrical shock.

With the exception of motor overload protection, electrical disconnects and over current protection are not supplied with the equipment.

#### **CAUTION:**

Use caution when working with the Auger—springing Auger may cause personal injury.



## General

### Support Information

The Chore-Time GENESIS® Straight-Line Feeding System has been designed to feed poultry types. Using this equipment for any other purpose or in a way not within the operating recommendations specified in this manual will void the warranty and may cause personal injury.

This manual is designed to provide comprehensive planning and installation information. The table of contents provides a convenient overview of the information in this manual.

## Manufacturer’s Recommendations: Birds per Pan

Type	Max weight and/or weeks of age	Feeders	Number of birds/pan
Broiler Breeder Pullet – rearing	0 – 18 weeks	GENESIS® Pullet	20-21
Broiler Breeder Pullet – rearing	0 – 18 weeks Hi-Yield	GENESIS® Pullet	20-21
Broiler Breeder Layer	17 + weeks	GENESIS® Breeder	18
Broiler Breeder Layer	17 + weeks Hi-Yield	GENESIS® Breeder	18

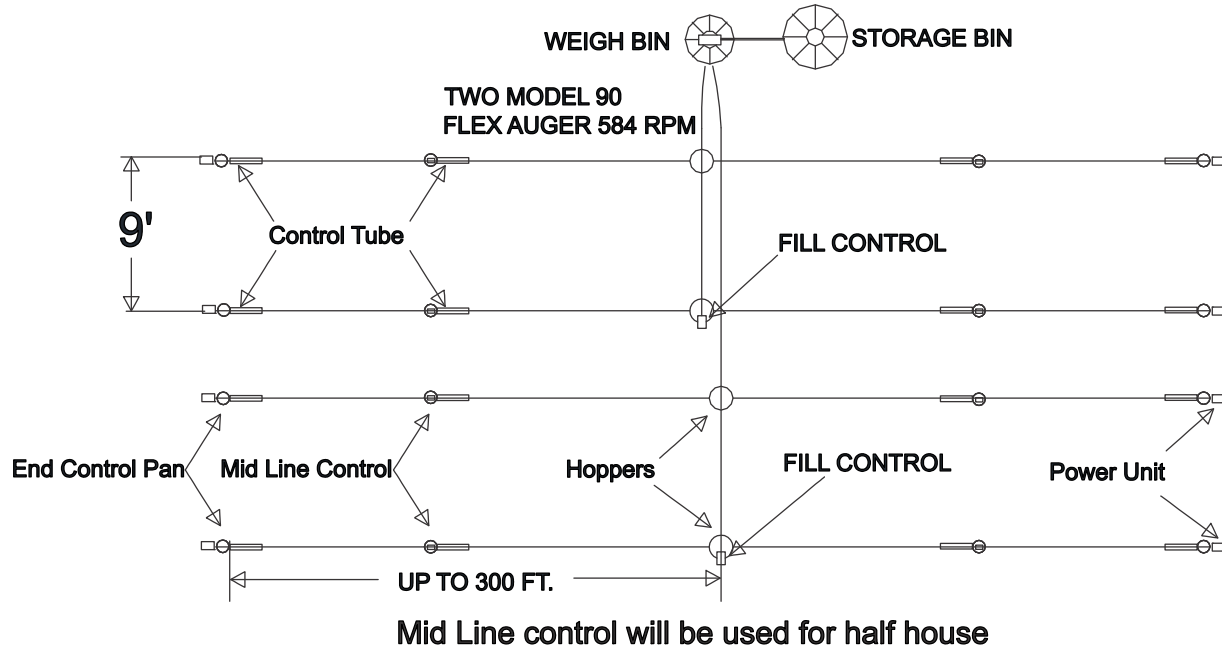
**\*Notice:** Please be advised that the maximum number of birds that may be successfully produced per feed pan may vary based upon such factors as climate, housing type or style, bird breeds, genetic factors of the birds at issue, grower management practices, etc. All other environmental and management circumstances, such as proper bird density per house, access to adequate nutrients in feed, access to adequate water supply, proper ventilation, adequate health care for the birds, and other similar factors, must meet industry standards and recommendations, if any, of applicable bird breeder companies.

**\* NOTICE:** The above Manufacturer’s recommendations do not constitute a product warranty and are in no way to be considered as a guarantee of performance for poultry production. In addition, the above information in no way alters or revises the terms and conditions of any applicable Chore-Time manufacturer’s warranty.

# Planning the System

Carefully planning the system prior to beginning the installation will save time and effort. Refer to the FLEX-AUGER® Fill System manual for fill system installation information and specifications.

## Planning your GENESIS® Straight-Line Pullet feeder



## Planning your GENESIS® Straight-Line Breeder feeder

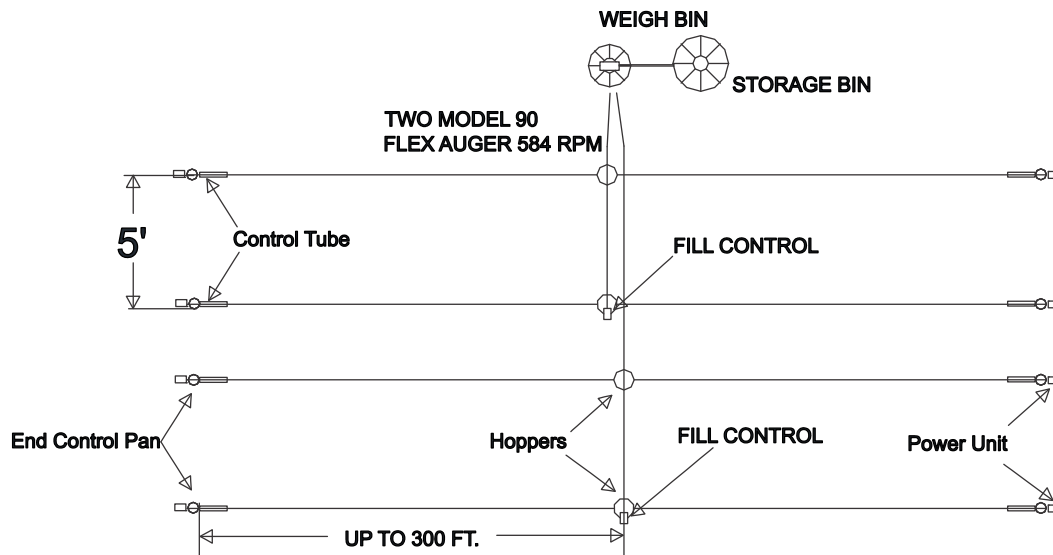


Figure 1. Planning the system

1. Select the house layout.

**Figure 1.** shows a house with four feeder lines. The max length from hopper to power unit is 300'. The feed line uses a 696 RPM power unit. With a Model C2 Plus Shallow control pan.

**Note:** The suspension drop lines are spaced 8' [2.4 m] apart all through the system. Systems using 10' [3 m] or 12' [3.6 m] tubes may be suspended on 10' [3 m] centers.

2. Determine feed bin location

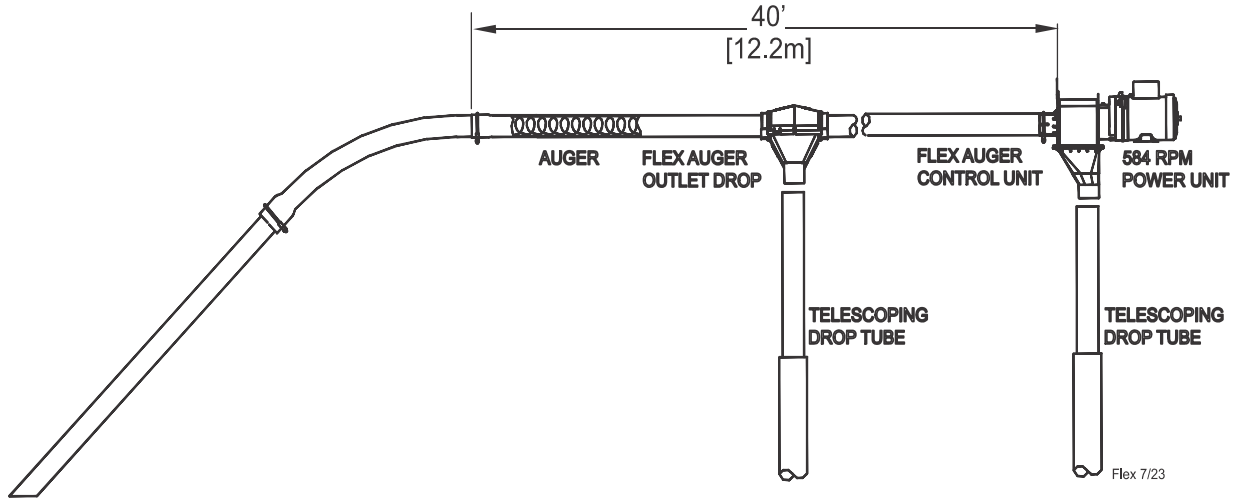
3. Determine the location of end controls and mid line controls.



### Planning your fill system:

The GENESIS® feeder will require one Model 90 @584 rpm for two boots. The fill system control will be operated by a drop tube switch. Feed will travel from the control unit to the hopper through telescoping drop tubes.

**Do Not short cut your fill system trying to use a smaller size fill system**



Sample FLEX-AUGER layout for reference only.

# General Installation Information

Please read the installation instructions in this manual prior to beginning the installation. This manual provides the necessary information on the installation, operation, and maintenance of the Chore-Time feeding equipment you have purchased.

## Capacities and specifications

The Genesis Straight-Line feeding system utilizes 696 RPM Power Unit Delivering approximately 35 pounds per minute, based on 40 # per cubic foot. A typical Genesis Straight-Line feeder is filled with a Model 90 fill system @ 60 hz 584 RPM. or a 580 RPM @ 50 hz. delivery rate @ 29 # which can satisfy two hoppers with twin boot.

The Genesis Straight-Line System is available with 10' 3 holes, 10' 4 holes, 12' 4 hole and 12' 3 hole tubes, for versatility of various building size, bird type and bird densities.

Single phase 60 Hz and single and three phase 50 Hz Power Units are available for the Genesis Straight-Line Feeders.

Systems up to 300' [91 m] require 3/4 HP 60 hz at 696 RPM or a 580 RPM 50 hz, Power Units.

## Laying out the Suspension System

1. Select the Suspension type.

A. For systems over 350' [107 m]

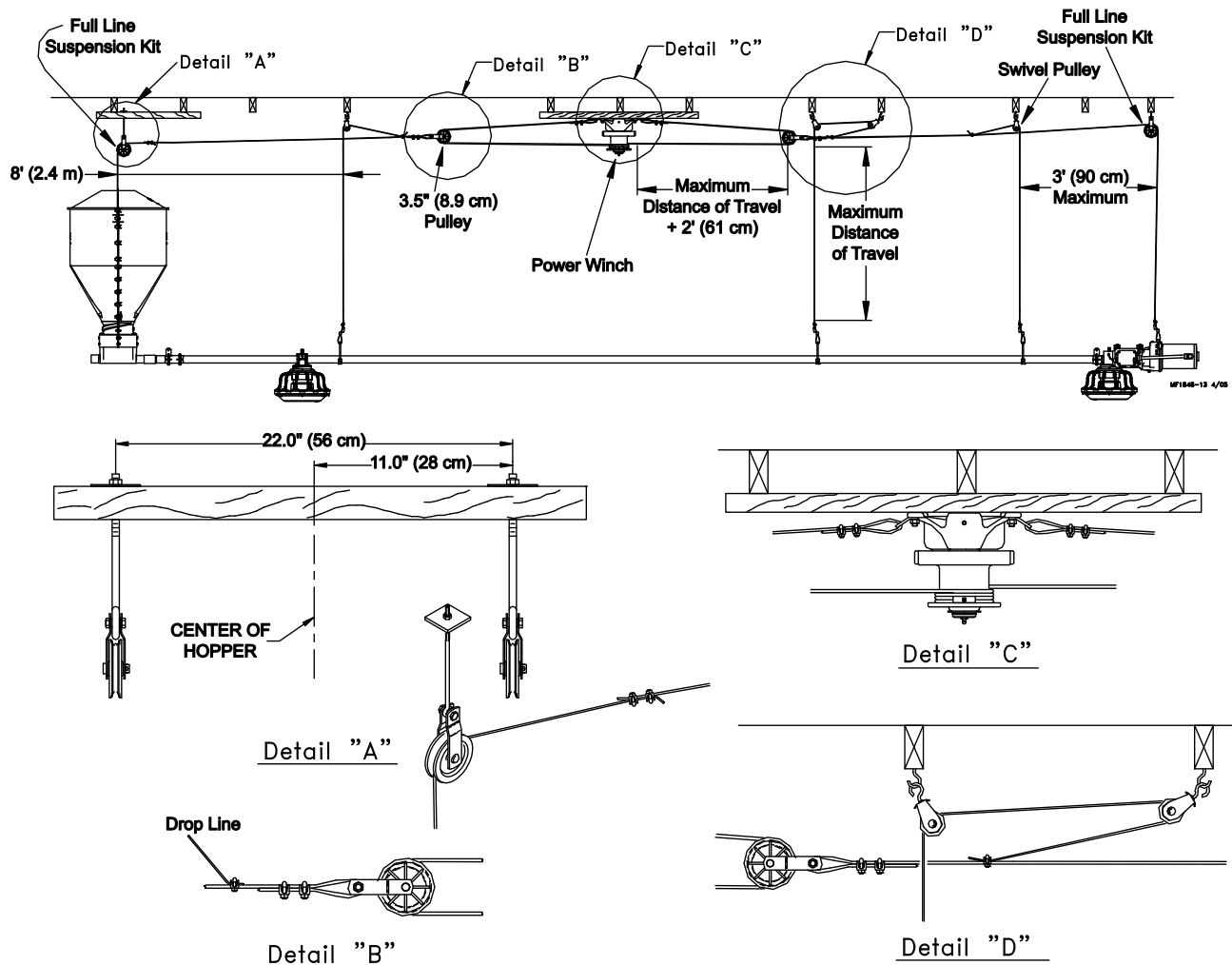
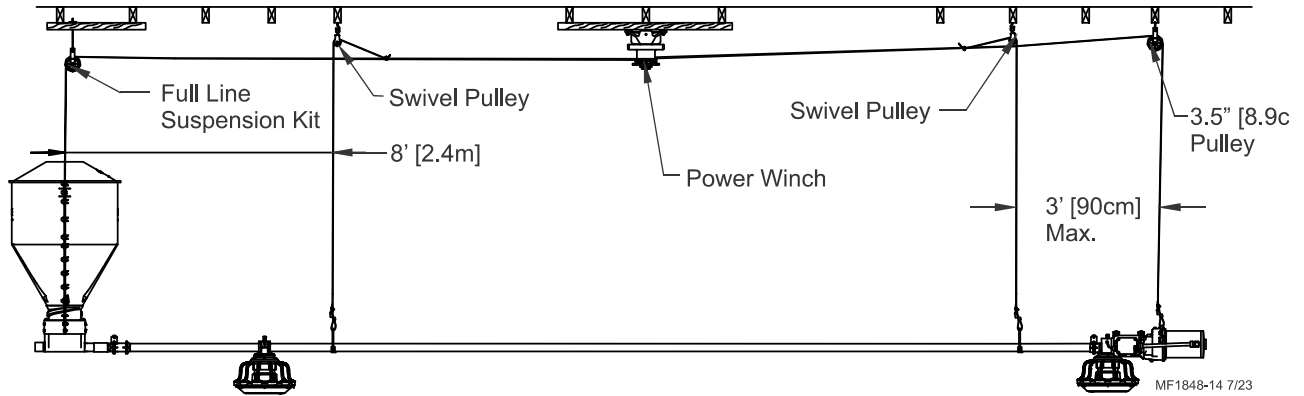


Figure 2. Suspension for systems over 350' [107 m]

B. For systems under 350' [107 m]



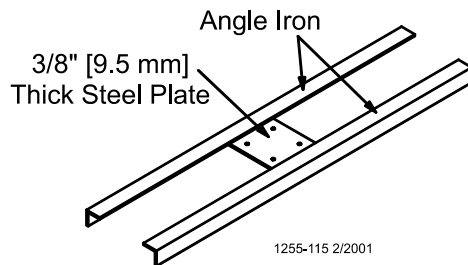
**Figure 3. Suspension for systems up to 350' [107 m]**

2. Locate the Power Lift Winch. The Power Lift Winch requires a support that will span, in a wood frame house at least 3 rafters, and in a steel frame house at least 2 rafters.
3. Locate the Power Unit and Feed Hopper. Special support is required at each Power Unit and Feed Hopper location.
4. Determine the Drop Location and length. Suspension systems are based on ceiling heights of 14' [4.3 m] with suspension drop points every 8' [2.4 m]. DO NOT EXCEED 10' [3 m] BETWEEN SUSPENSION DROPS.
5. Determine the location for Screw Hooks. Mark a straight line or use cable to locate Screw Hooks. Use the offset of Screw Hooks where necessary.

## Installing the Suspension System

### Power Lift Winch Installation

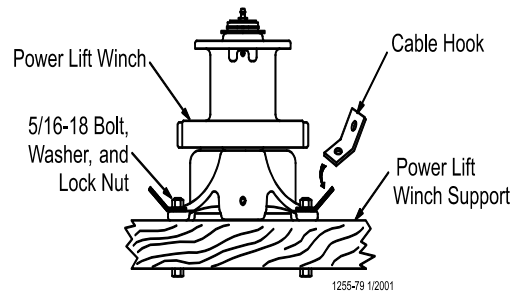
1. Bolt the Power Winch, fully assembled, to the Power Lift Winch Support, either a 2" x 8" [50x200 mm] board that will span at least 3 rafters or a 3/8" [9.5 mm] thick steel plate welded to two pieces angle iron that are each long enough to span at least 2 rafters, using 5/16-18 hardware supplied in the Hardware Package. The brake mechanism will extend toward one side.



**Figure 4. Optional Power Lift Winch support detail**

Install a Cable Hook, supplied in Hardware Package, between the mounting bolt and Power Winch frame, as shown in **Figure 5**.

2. Attach the Power Lift Winch Support (with the Power Winch secured) to the ceiling at the center of the feeder line. See **Figure 6**. The Power Lift Winch Support must be parallel to the feeder line and must span at least 3 rafters in a wood frame house and 2 rafters in a steel frame house.



**Figure 5. Assembling the Power Winch to the Rafters**

If the hopper is located at the center of the feeder line, locate the Power Winch a few feet offset from the center of the feeder line. However, the Winch Drum must be directly in line with where the main cable is to be installed.

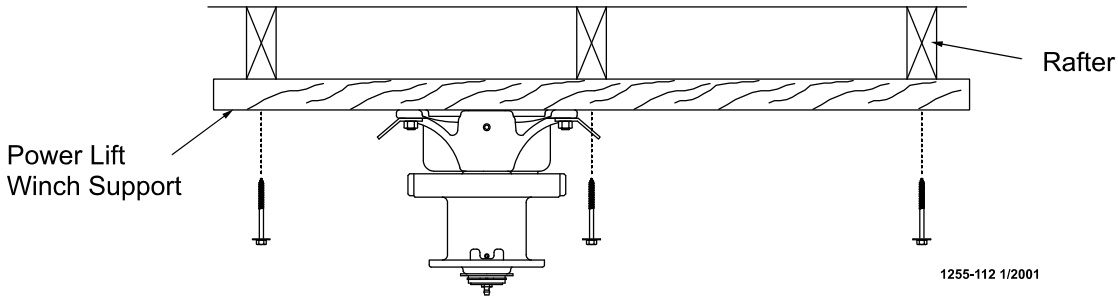


Figure 6. Mounting the Power Lift Winch and Support to the Rafters

## Installing the Main Winch Cable

The Suspension Systems are based on ceiling heights of 14' [4.3 m] with Suspension Drop points every 8' [2.4 m]. DO NOT EXCEED 10' [3 m] BETWEEN SUSPENSION DROPS. Refer to suspension section in this manual for installation details.

Adequate overhead structure must be provided to support the weight of the feeders, hoppers, power units, etc. The Suspension System is the same for the straight-line Genesis. The type of installation required depends on the feeder line length.

### IMPORTANT: Special support is required at each Hopper location.

- Power Unit Locations: **The Feeder Line must be supported within 3' [.9 m] of the Power Unit.** This is in addition to the required Power Unit suspension. If the Control Unit or Hopper does not come out directly under a truss, fasten a pulley to a 2" x 8" [50 x 200 mm] board or steel angle that will span 2 trusses and is capable of supporting 300 lbs [136 kg] for the Hopper and 75 lbs [34 kg] for the Control Unit.

- Feed Hopper Locations: **When steel hoppers with center suspension are used, see figure 7, the feeder line must be supported within 1' [30 cm] of the feed hopper.** **When plastic hoppers are installed only 2 point suspension can be used, see figure 8, this does not require additional supports.** This is in addition to the required Feeder Hopper suspension. After determining the type of suspension system required, decide where the Feeder Line is to be installed. Mark a straight line on the ceiling or rafters the full length of the Feeder Line. Use a string, chalk line, or the winch cable, temporarily attached with staples, to mark the line. Center the line directly over where the Feeder Line is to be installed.

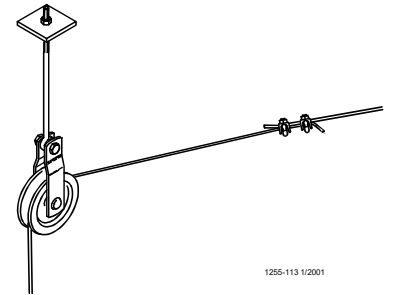


Figure 7. Steel Hopper Suspension

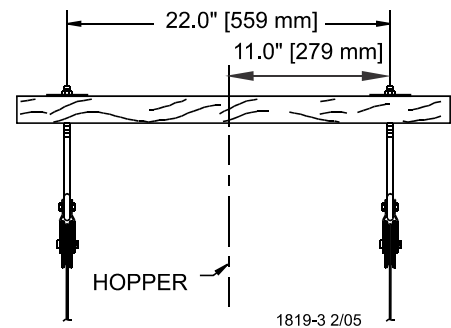


Figure 8. Plastic Hopper Suspension

3. Extend the 3/16" [5 mm] Main Winch Cable the full length of the feeder line. Attach the cable temporarily to the ceiling with nails, staples, or some type of fasteners. **Figure 9** shows a double back arrangement for feed lines over 350' [107m]

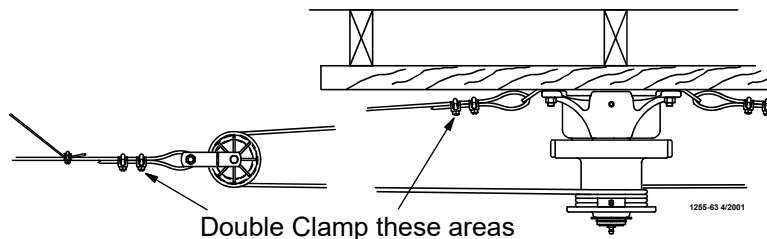


Figure 9. Double back arrangement for feed lines over 350' [107 m]

- Route the cable through the Winch Drum Relief located near the bottom of the drum. Tighten the set screw to anchor the cable to the drum. See Figure 10.

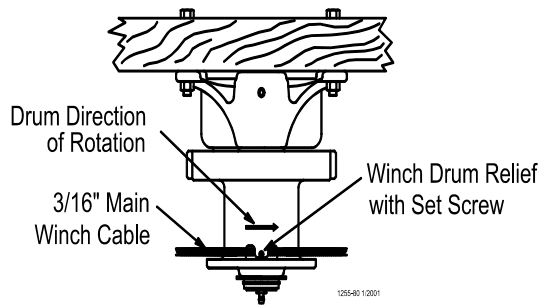


Figure 10. Attaching the Cable to the Power Winch

- Turn the winch drum one full revolution. Guide the cable against the flange at the bottom of the winch drum. The cable must not wrap over itself on the drum, but should be wrapped as close as possible to each previous wrap. See Figure 11.

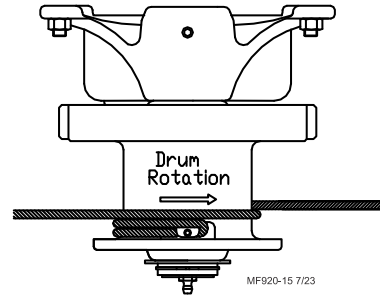


Figure 11. Power Winch Drum Rotation

### Screw Hook Installation

The recommended distance between the drops for the Genesis FEEDER is 8' [2.4 m] on center. Do not exceed 10' [3 m] spacing on drop lines.

If the distance raised is greater than the distance between the drop spacings, offset the hooks 3" [7.6 cm] to each side of the line to prevent the cable clamps from catching the pulleys, see Figure 12.

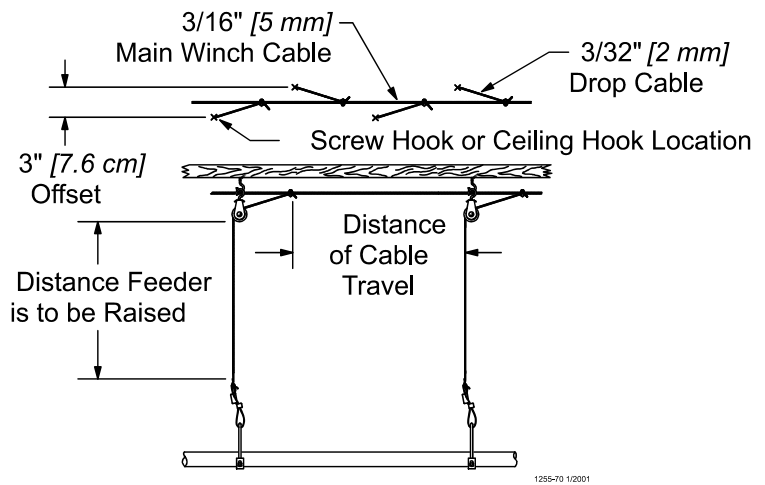


Figure 12. Drop Line Off Set Detail

Screw the hook into the truss the full length of the threads to prevent bending.

The openings of the screw hooks must be pointed away from the direction of travel when the Power Winch raises the feeder line. See Figure 13.

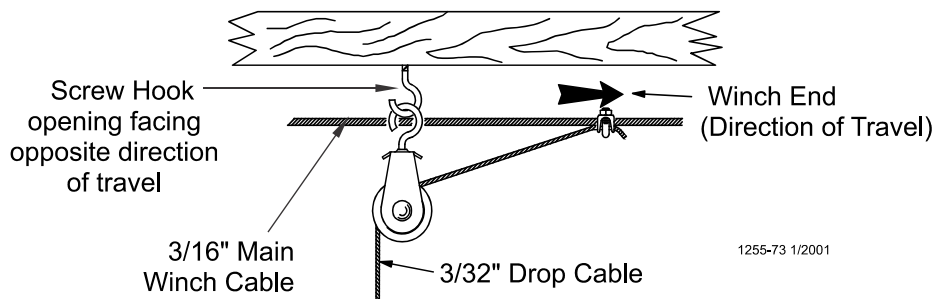
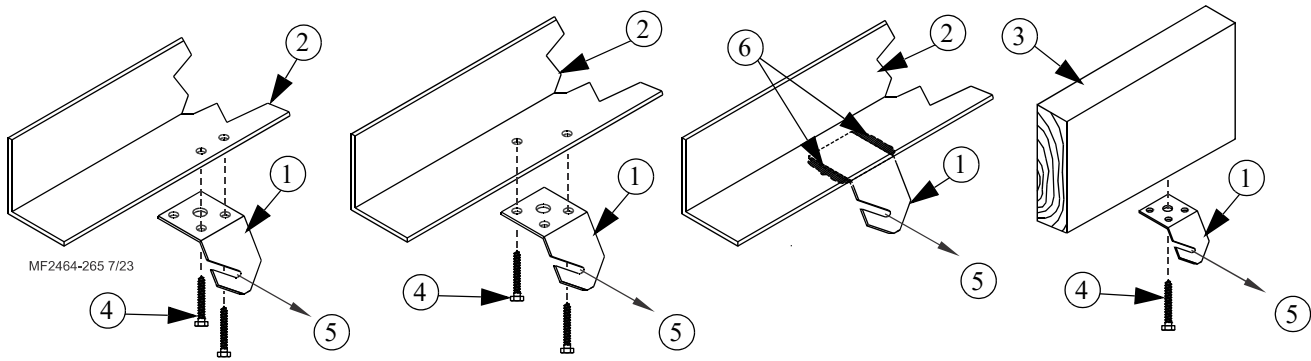


Figure 13. Screw Hook Installation

### Ceiling Hook Installation



Item	Description	Part No.
1	Ceiling Hook	28550
2	Steel Truss	--
3	Wood Truss	
4	1/4-20 Lag Screw	--
5	Cable Travel Direction	--
6	Weld	--

Figure 14. Ceiling Hook Installation

1. After securing the Ceiling Hook to the truss, slide the hook of a Swivel Pulley into the slot, as shown in Figure 15.

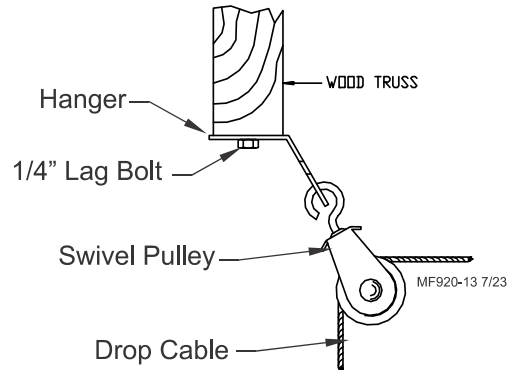


Figure 15. Pulley Installation

### Drop Installation

Refer to page 13 Figure 13.

1. Attach a 3004 Pulley to each hook.
2. Thread the end of the 3/32" or 1/8" cable through the pulley toward the winch. Clamp this end to the 3/16" winch cable about 6" [150 mm] from the last pulley, using a 3/16" cable clamp. See applicable figure; Figure 13 or 16.
3. Allow enough cable length for installation of the Adjustment Leveler. Sufficient cable is included to provide "throwbacks" on drops located beneath and near the winch. Figure 16 shows a "throwback" cable arrangement.

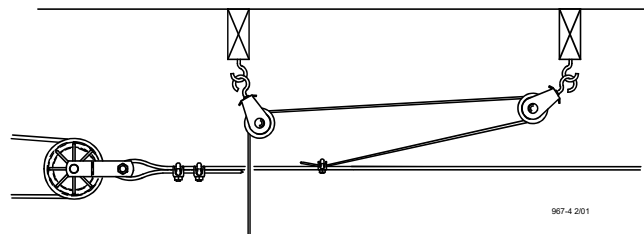


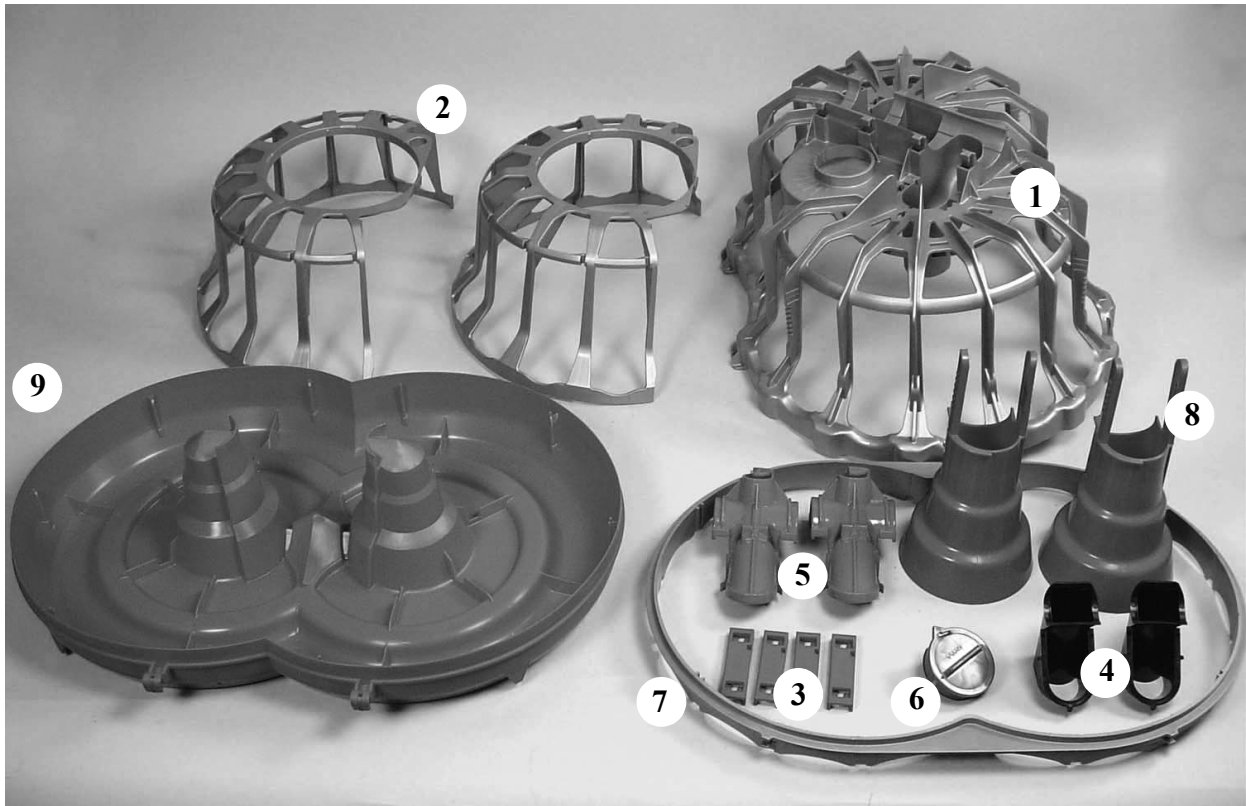
Figure 16. "Throwback" cable arrangement

4. Begin installing suspension drops at the winch and proceed to the ends of the feeder line.

Keep the main cable tight between drops. It may be necessary to hang a weight on the end of the cable to maintain tension on the line.

# Breeder Hen Feeder Pan Assembly

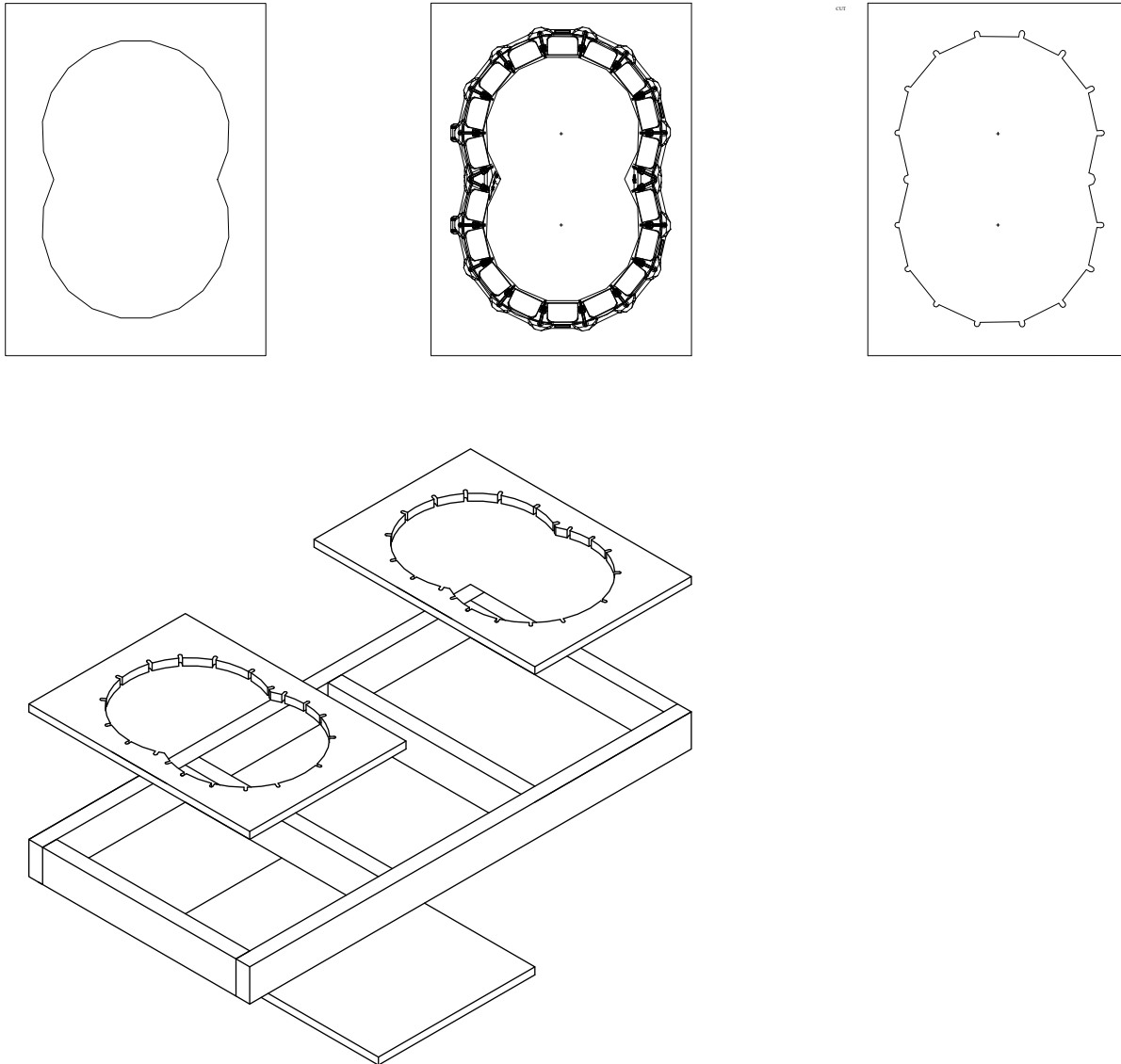
Locate the parts shown in the photo below.



ITEM	PART NO.	DESCRIPTION
1	50339	GENESIS GRILL
2	50337	ADJUSTABLE GRILL
3	51774	SLIDE LOCK
4	51862	FEED CHUTE
5	50340	SUPPORT CAP
6	50338	ADJUSTMENT KNOB
7	50341	HEIGHT RING
8	50457	FEED CONE
9	50342	GENESIS PAN

## Feed Pan Assembly Box Construction

Chore-Time recommends building an assembly box to aid in assembling the feeder pans



**Figure 17. Feed Pan Assembly Box Construction**

To build the assembly box use a 19.125" [543 mm] x 24" [609 mm] piece of plywood, two 14" [356 mm] and two 22" [584 mm] long pieces of 2" [51 mm] x 4" [113 mm] boards.

1. Cut a piece of 3/4" [19 mm] plywood 17" [432 mm] x 24" [609 mm].
2. Center the grill on the 17" [432 mm] x 24" [609 mm] piece of plywood. Use a pencil and draw around the inside edge of the grill as shown in **Figure 17**. Mark a "V" at each strut location.
3. Remove the grill.
4. Use a spade bit to drill a hole at each strut location as shown in **Figure 17**.
5. Use a sabre saw to cut along the line.
6. Use four 21" [534 mm] and two 48" [1219 mm] 2" [51 mm] x 6" [236 mm] to construct the box sides. Nail the 3/4" [19 mm] plywood fixture to the box.

It is important to use 6" [152 mm] side legs for the box. Smaller board will not allow sufficient depth for the grill to be placed in the box face down.



## Breeder Pan Assembly Procedure

The following procedure includes all possible components for this feeder. If your installation does not include one of the components skip over it and go to the next step.

1. Place a grill in the pan assembly box fixture.
2. Install two adjustable grills. Make sure to line up the arrows on the teeth for proper installation see **Figure 19**.



Figure 18. Place Grill into Assembly Fixture

**Tip:** Prior to installing the adjustable grills align the teeth as shown in Figure 19. Hold the grills together at the teeth and press them through the snaps as shown in Figure 19.

Align teeth on adjustable grills as shown below.

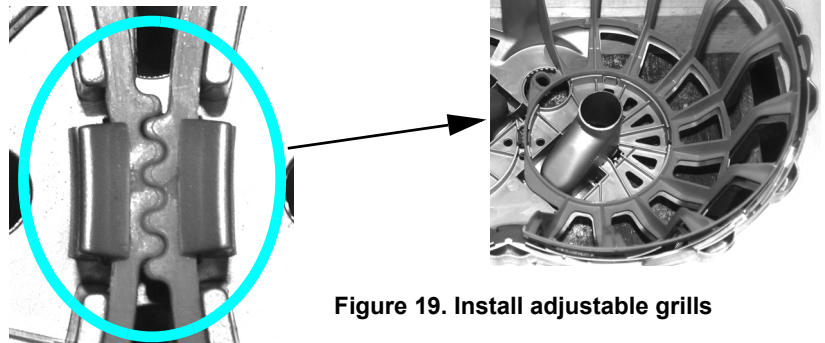


Figure 19. Install adjustable grills

3. Install two feed cones see **Figure 20**..

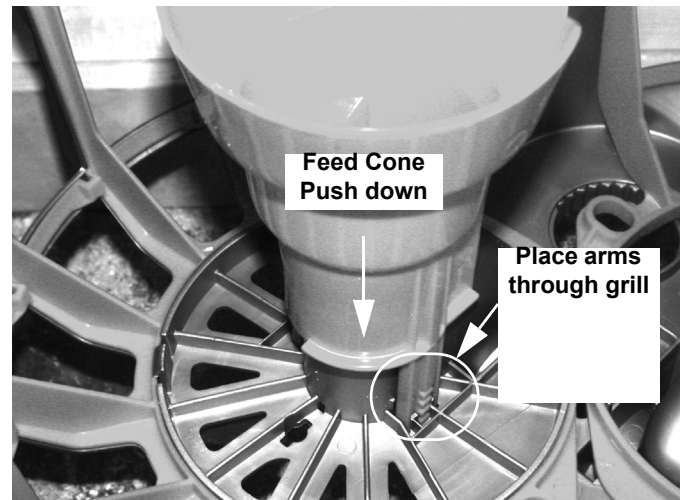
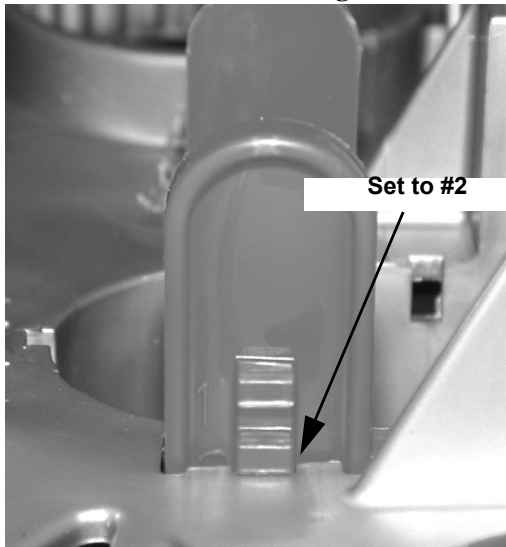
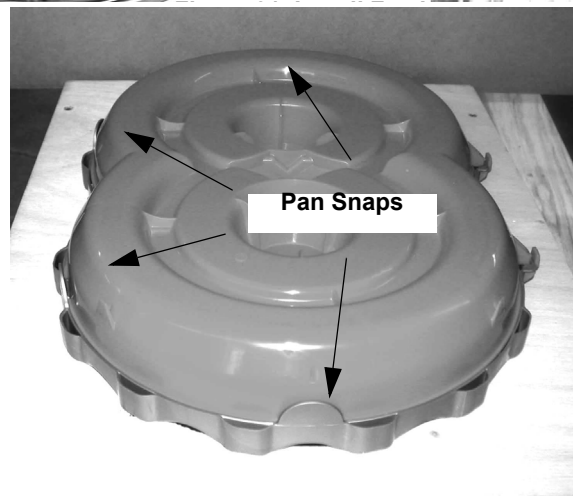
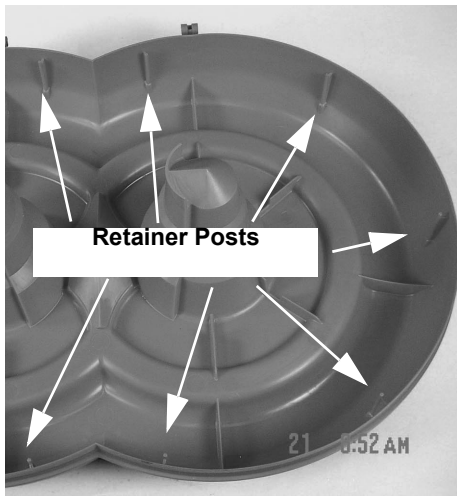
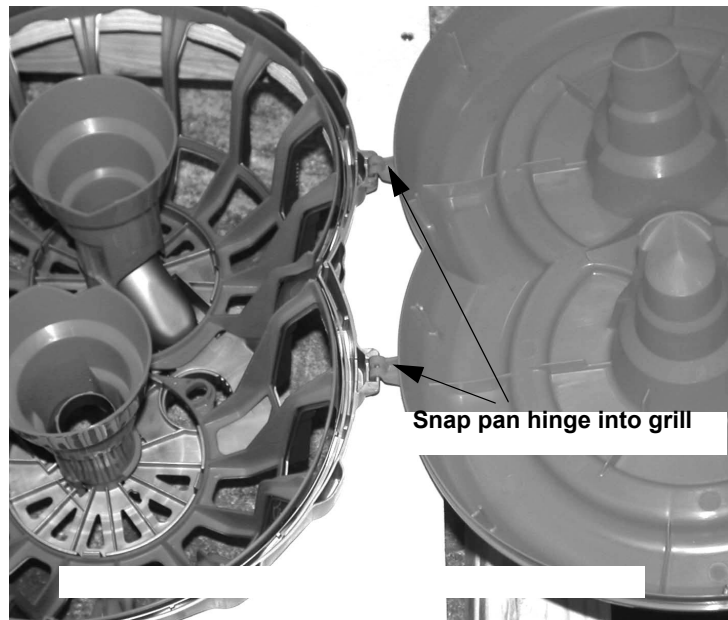


Figure 20. Install feed cones

4. Install the feeder pan.
5. Remove pan assembly from the assembly fixture.
6. **BE SURE ALL** retainer posts in the pan are inside the lower ring on the adjustable grills.



### Feeder Pan and Tube Assembly Fixture Construction

Chore-Time recommends building an assembly box to aid in assembling the feeder pans.

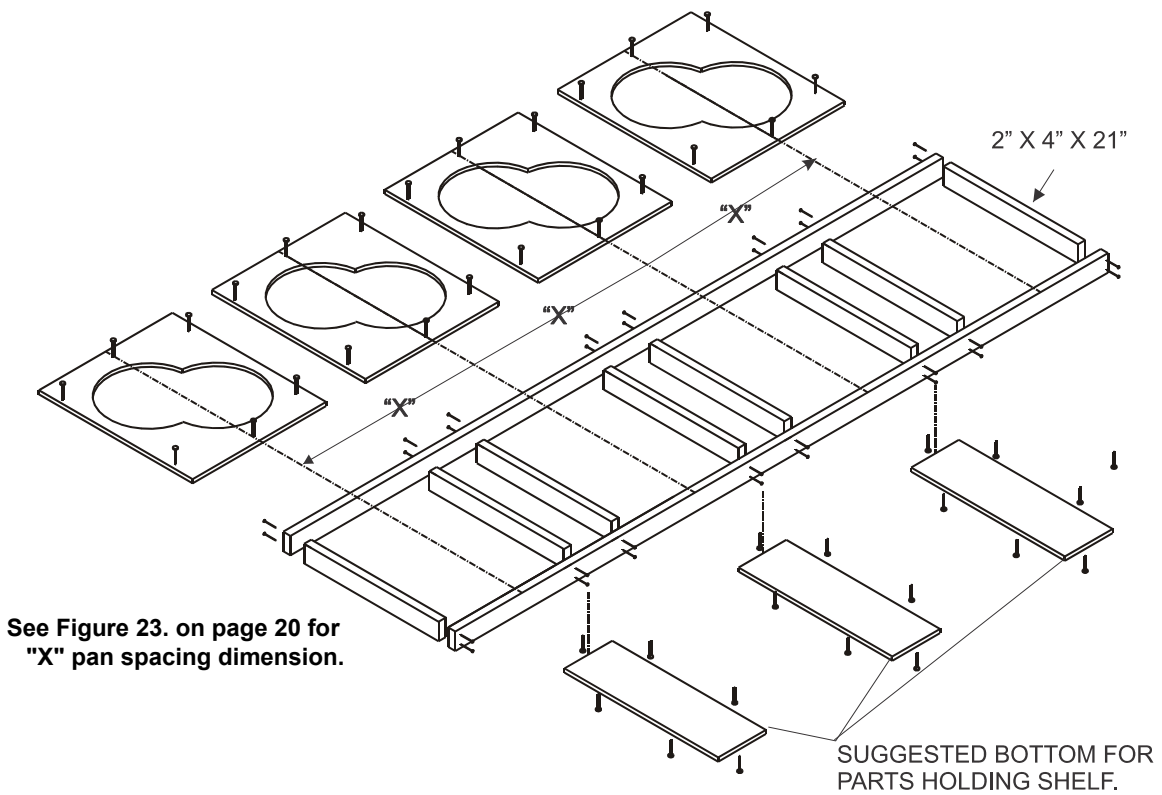
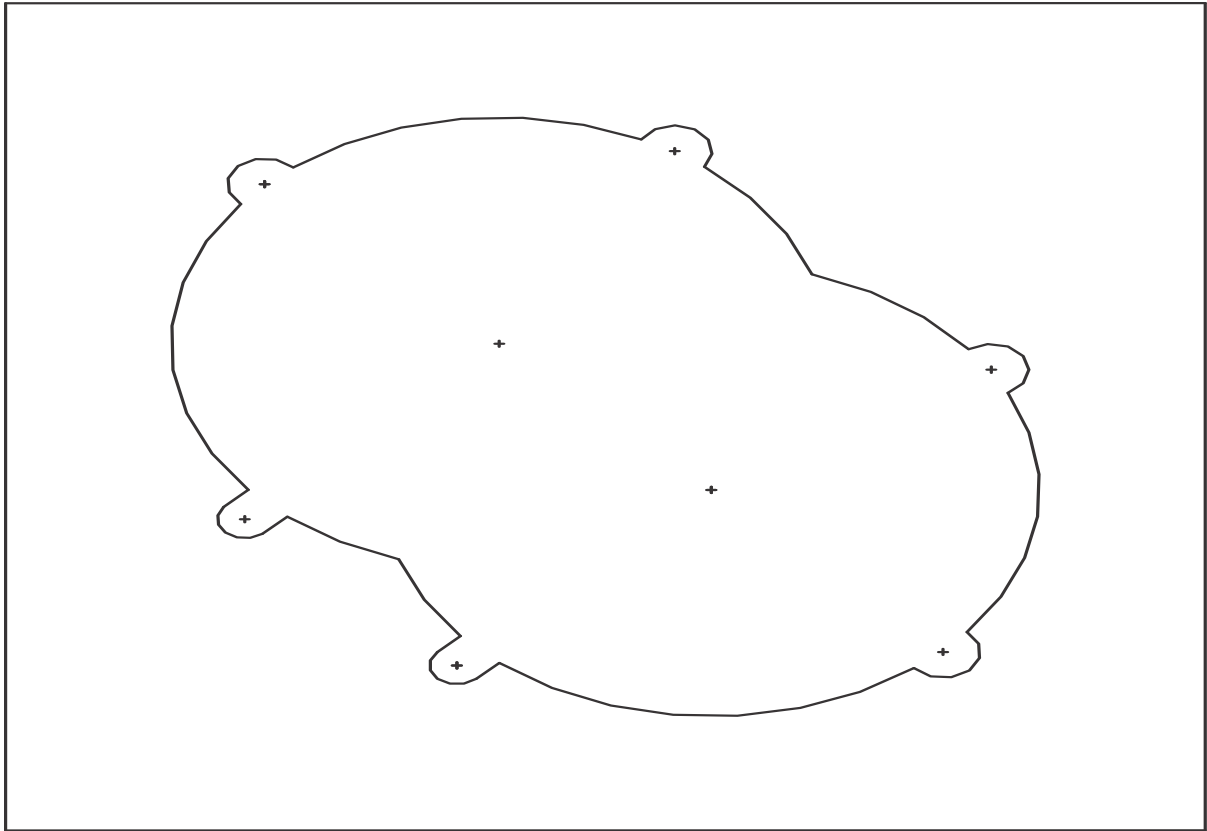
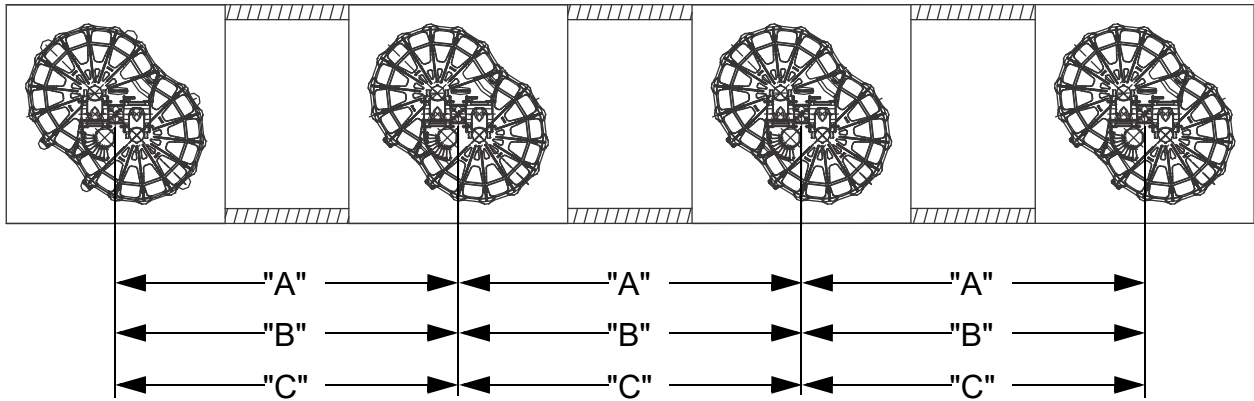


Figure 22. Feeder Pan and Tube Assembly Fixture Construction

## Feeder Pan and Tube Installation Procedure

The following procedure includes all possible components for this feeder. If your installation does not include one of the components skip over it and go to the next step.

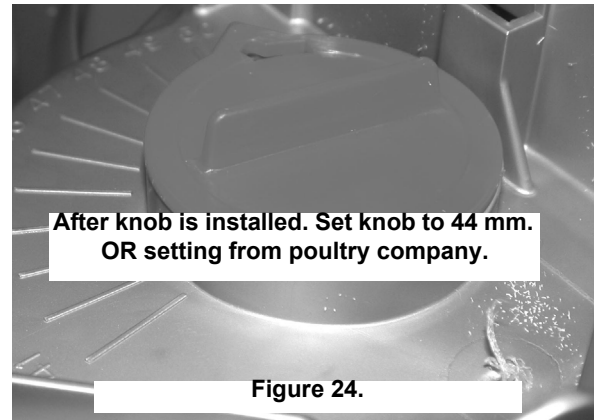
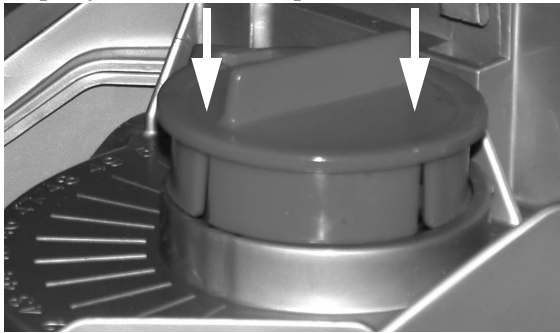
1. Place the assembled feeder pans into the assembly fixture with same orientation.



Genesis Feeder Tube Spacing:  
 12 Ft. 4 Hole- 36 Inch ("A")  
 10 Ft. 4 Hole- 30 Inch ("B")  
 10 Ft. 3 Hole- 40 Inch ("C")  
 12 Ft. 3 Hole- 48 Inch ("C")

Figure 23. Pan Spacing

2. Install one adjustment knob per pan assembly. The adjustable grills should be set full open (50mm). Then snap adjustment knob in place.



3. Install two feed chutes per pan assembly.

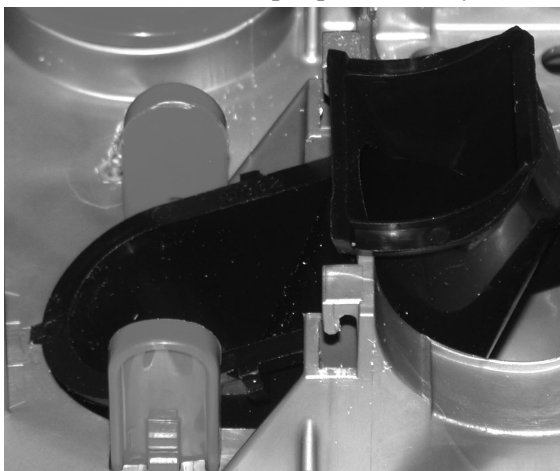
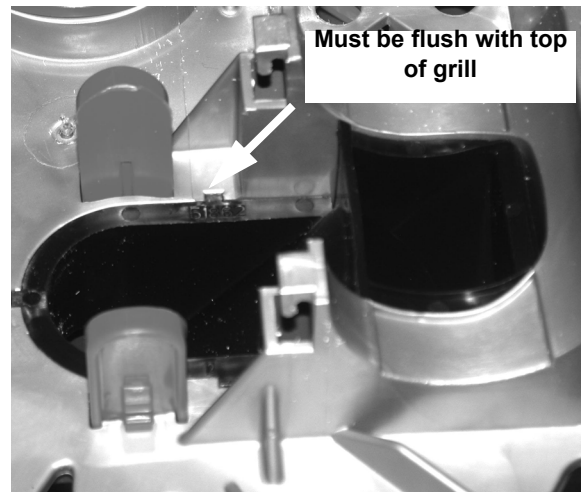


Figure 25.



4. install height adjustment ring. The height setting will determined by the poultry company.

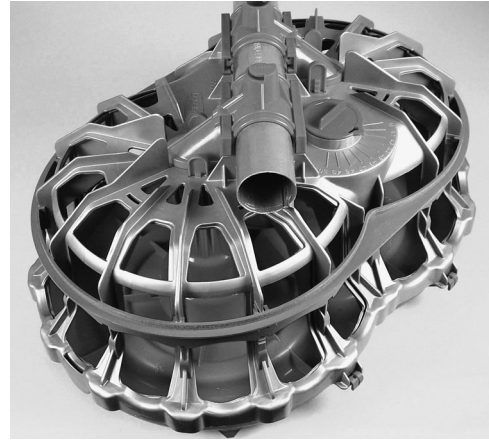
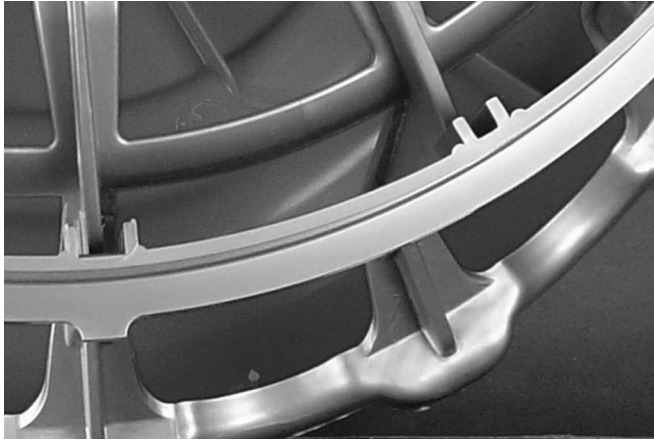
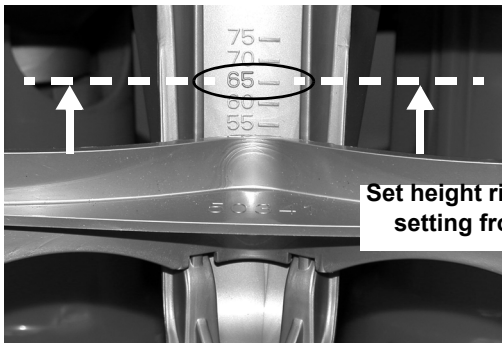


Figure 27.



Set height ring to 65mm OR height setting from poultry company

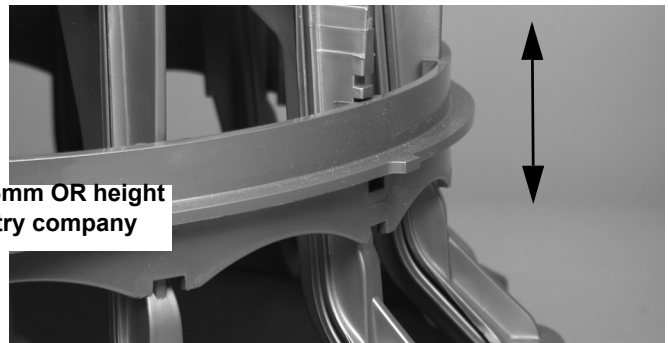
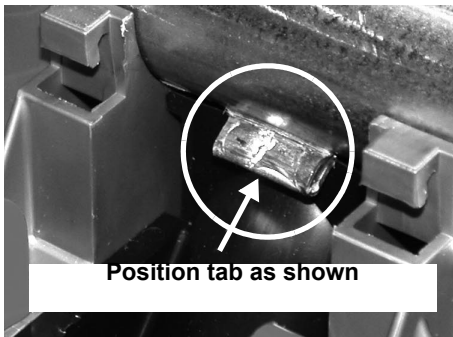
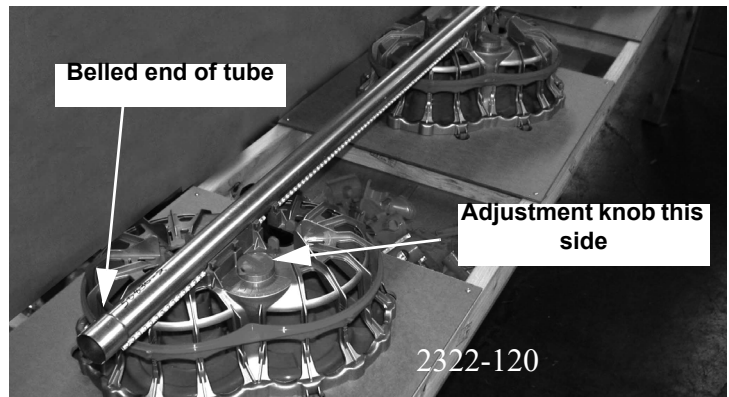


Figure 28. Height Ring Installation

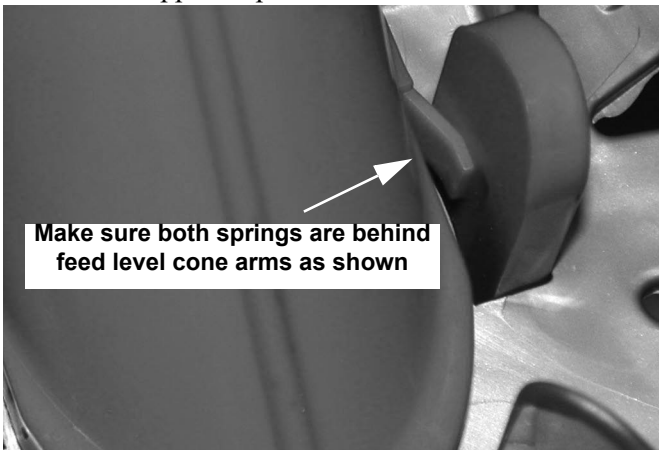
5. Install the feeder tube to the feeder pan assemblies.



Position tab as shown



6. Install two support caps over the feeder tube.

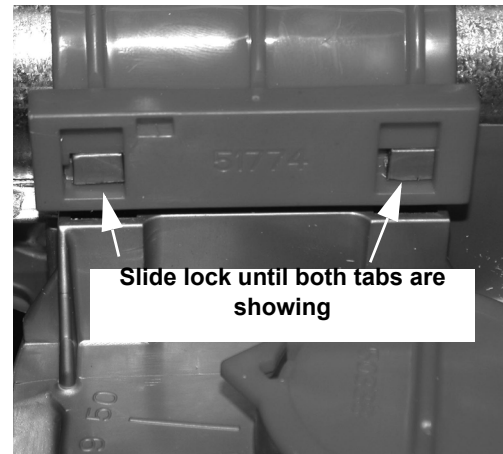
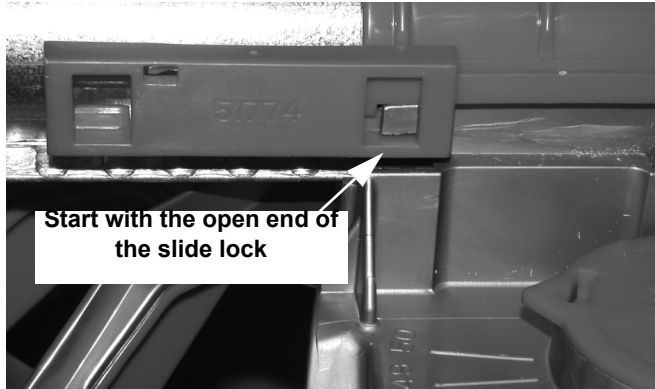


Make sure both springs are behind feed level cone arms as shown

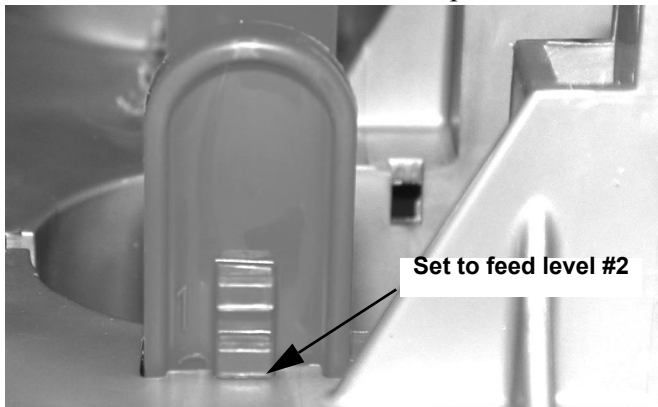


Figure 29. Support Cap Installation

7. Install four slide locks per pan. Start the open end of the lock to slide over the support cap and grill top.



8. Be sure that all feed tube are set to #2 position



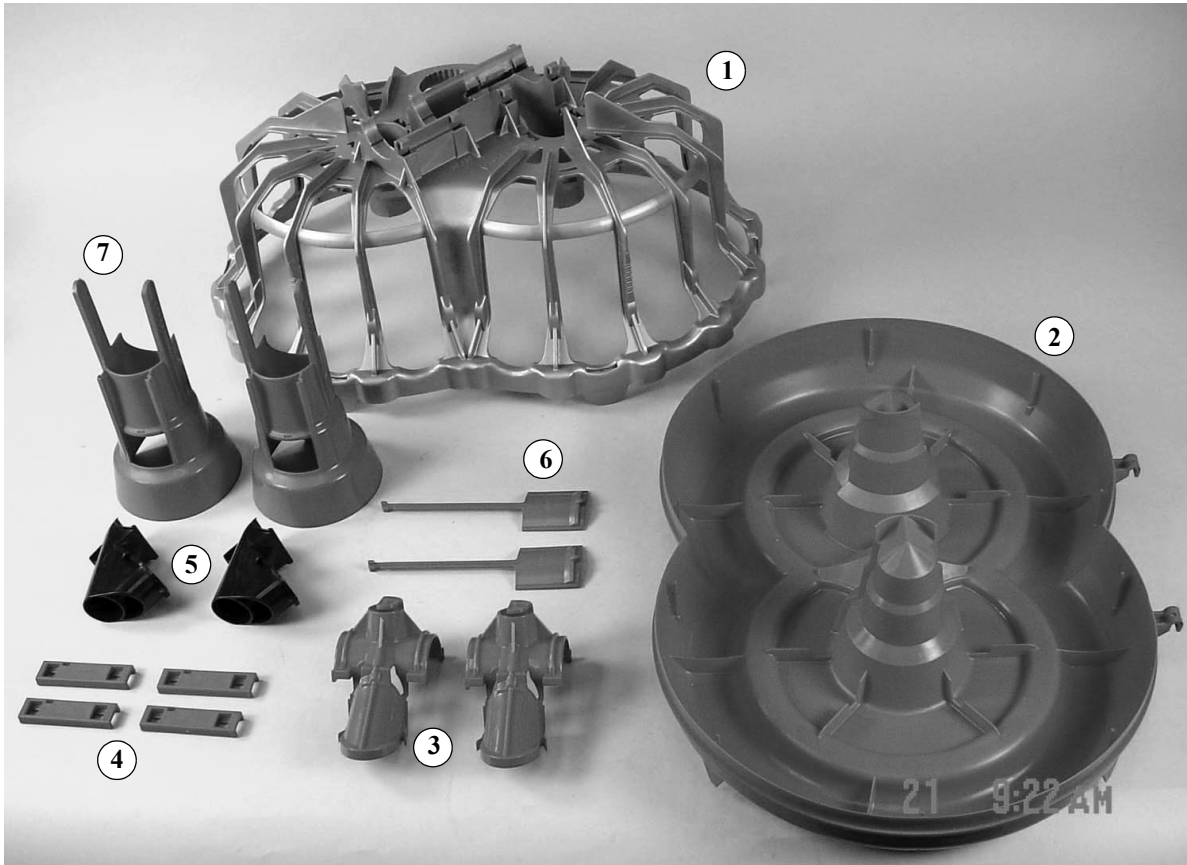
9. Remove the tube assembly from the fixture and continue assembling the remaining feeder pans and tubes.

### Assembly Check List

1. All pans have two feed cones, see page 17.
2. Feed level cone setting on #2, see page 22.
3. All pans have two adjustable grills, see page 17.
4. The adjustable grill bottom ring is setting inside the retainer posts on pan, see page 18.
5. Adjustment knob installed and set, see page 20.
6. Height ring set to 65mm OR recommendation from poultry company, see page 21.
7. Adjustable grill width set to 44mm OR recommendation from poultry company, page 20.
8. All four pan snaps are snapped in properly, see page 18
9. All pans are installed in the correct direction, see page 21.
10. All pans have two feed shuts installed, see page 20.
11. All pans have two support caps installed, see page 21.
12. springs are behind feed level cones arms, see page 21.
13. Slide lock is installed with two tabs showing, see page 22.

# Breeder Pullet Feeder Pan Assembly

Locate the parts shown in the photo below.



ITEM	PART NO.	DESCRIPTION
1	50339	GENESIS GRILL
2	50342	GENESIS PAN
3	50340	SUPPORT CAP
4	51774	SLIDE LOCK
5	51862	FEED CHUTE
6	50345	FEED GATE
7	50344	FEED CONE W/WINDOW

## Feed Pan Assembly Box Construction

Chore-Time recommends building an assembly box to aid in assembling the feeder pans

1. Cut the 2 x 4 lumber and plywood panels fasten together as shown.
2. Center the grills on the plywood and use a pencil to draw around the inside edge of the grill. Mark a "V" at each strut location.
3. Remove the grill.
4. Use a spade bit to drill a hole at each strut location as shown.
5. Use a sabre saw to cut along the line.
  - It is important to use 6" [152 mm] side legs for the box. Smaller board will not allow sufficient depth for the grill to be placed in the box face down.

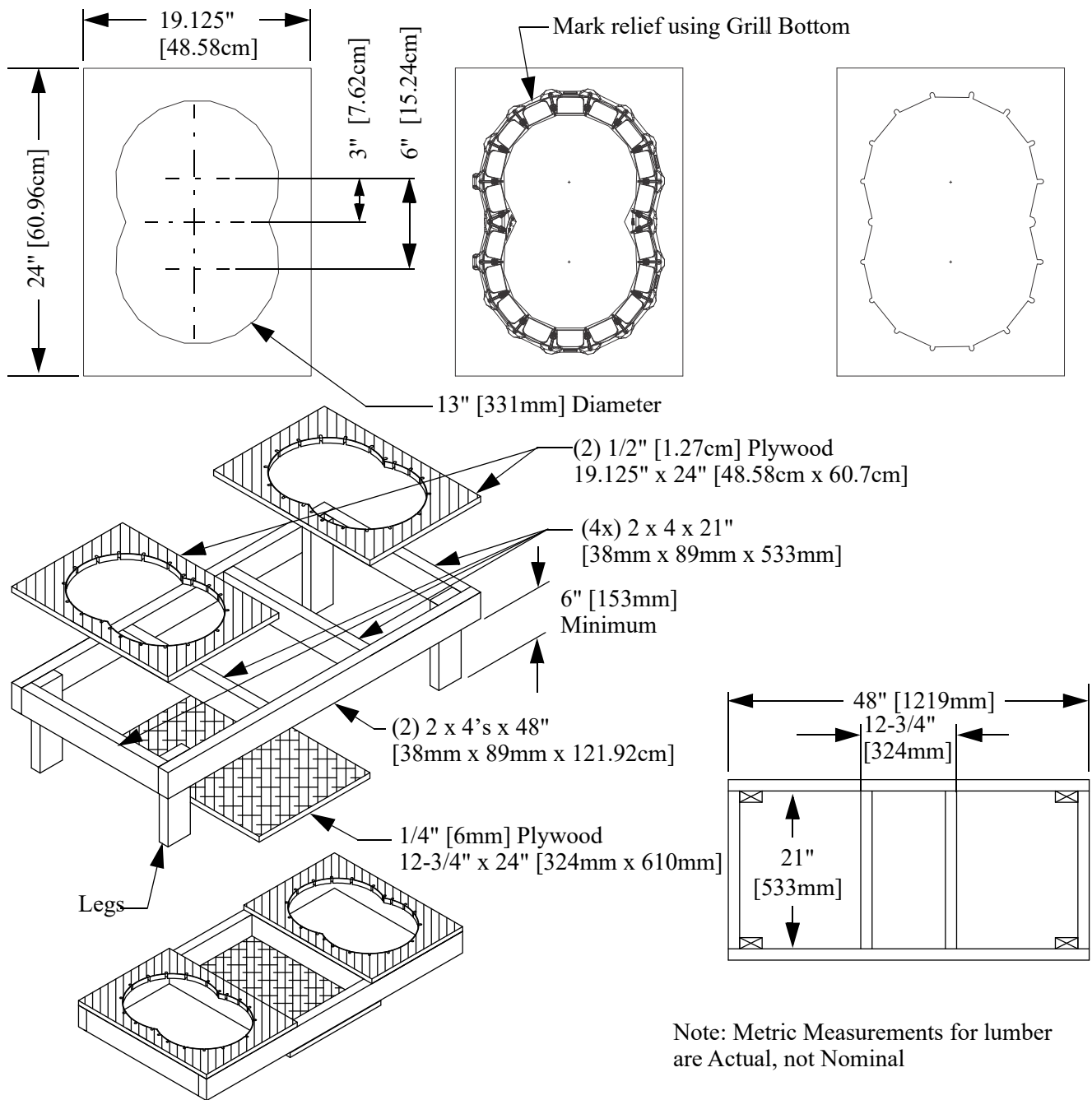


Figure 30. Feed Pan Assembly Box Construction



### Pullet Pan Assembly Procedure

The following procedure includes all possible components for a pullet feeder pan.

1. Place a grill in the pan assembly box fixture.

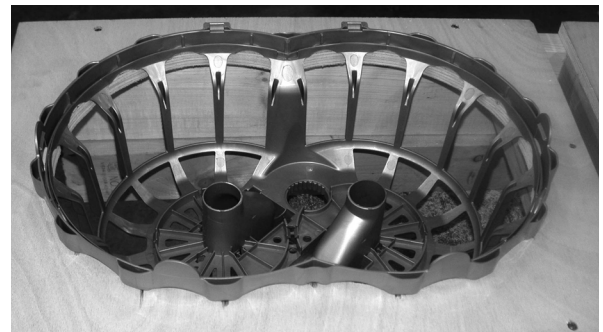
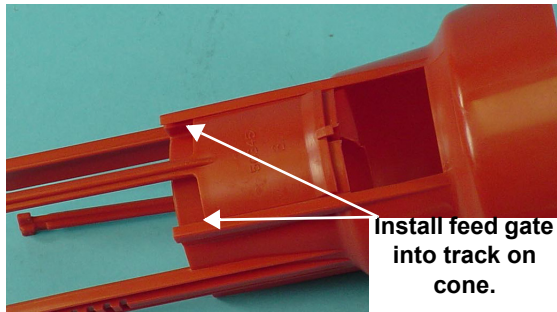


Figure 31. Place Grill into Assembly Fixture

2. Install two feed cones see Figure 32..

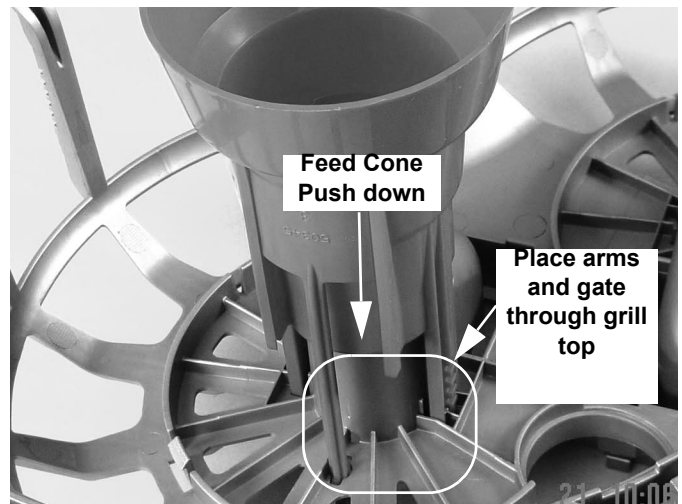
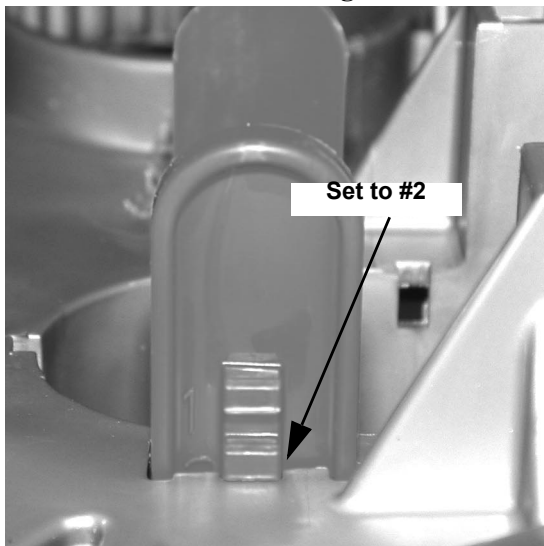
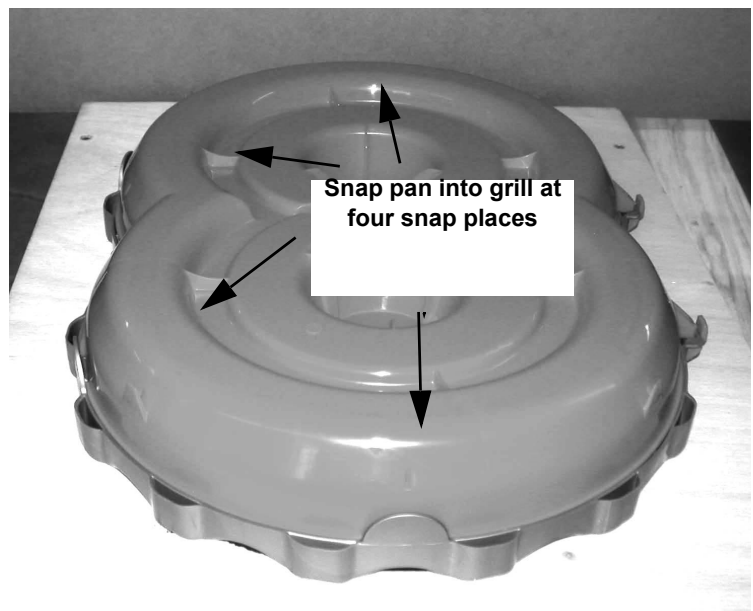
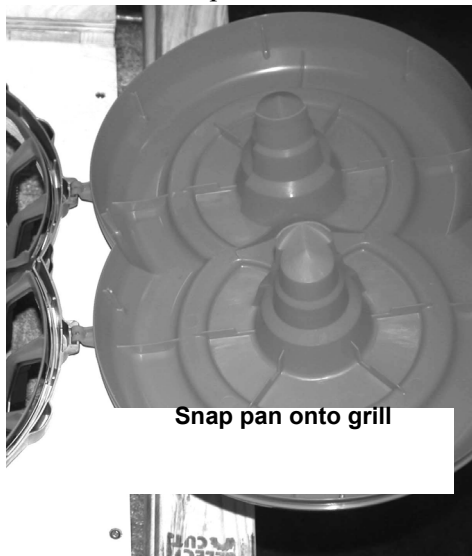


Figure 32. Install feed cones

3. Install the feeder pan.



4. Remove pan assembly from the assembly fixture.

### Feeder Pan and Tube Assembly Fixture Construction

Chore-Time recommends building an assembly fixture to aid installation of the feed pans to the feeder tube.

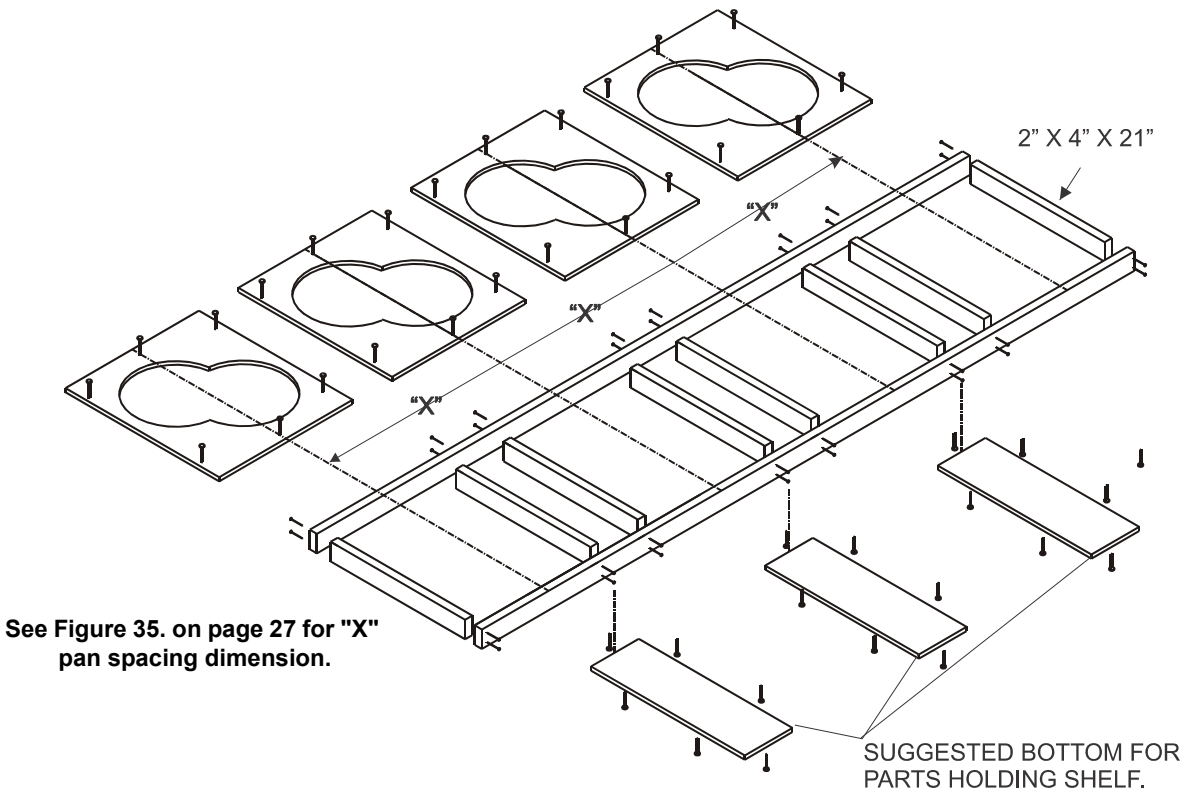
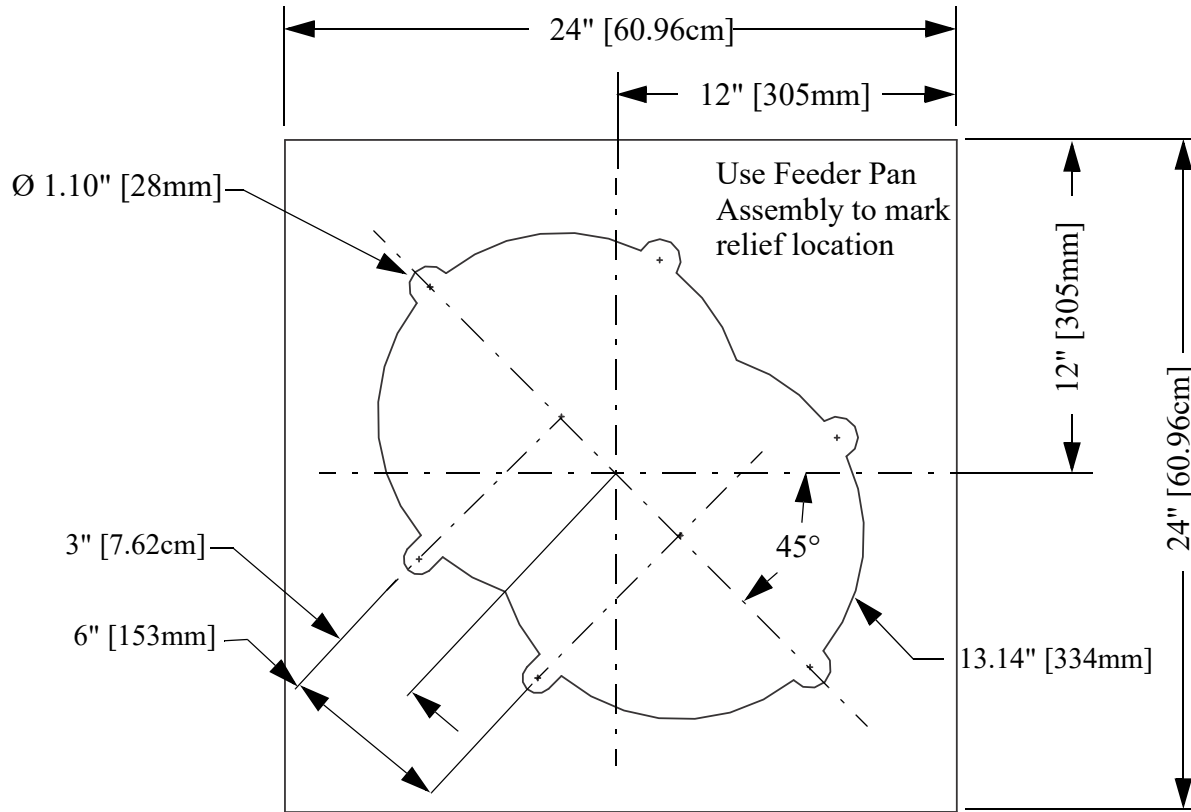
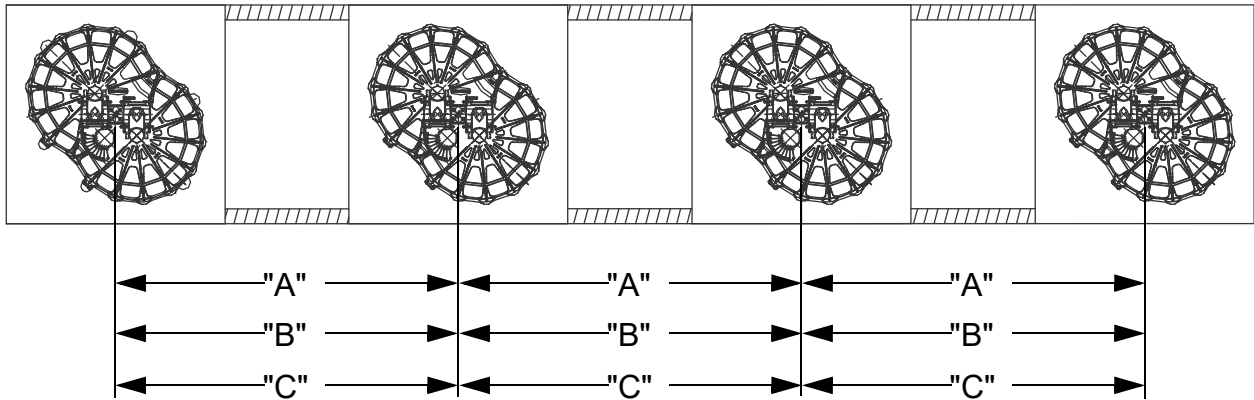


Figure 34. Feeder Pan and Tube Assembly Fixture Construction

## Pullet Pan and Tube Installation Procedure

The following procedure includes all possible components for this feeder. If your installation does not include one of the components skip over it and go to the next step.

1. Place the assembled feeder pans into the assembly fixture with same orientation.



Genesis Feeder Tube Spacing:  
 12 Ft. 4 Hole- 36 Inch ("A")  
 10 Ft. 4 Hole- 30 Inch ("B")  
 10 Ft. 3 Hole- 40 Inch ("C")  
 12 Ft. 3 Hole- 48 Inch ("C")

Figure 35. Pan Spacing

2. Install two feed chutes per pan assembly.

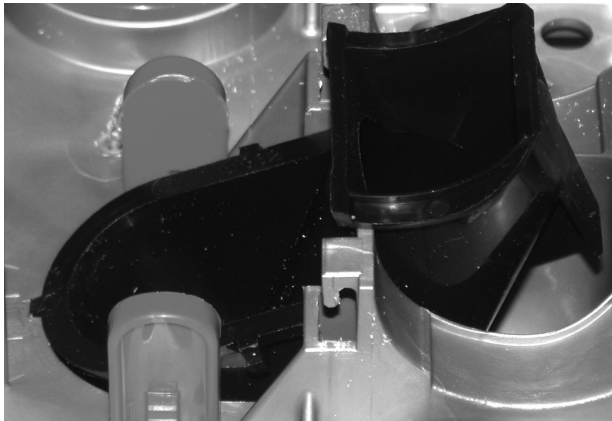


Figure 36.

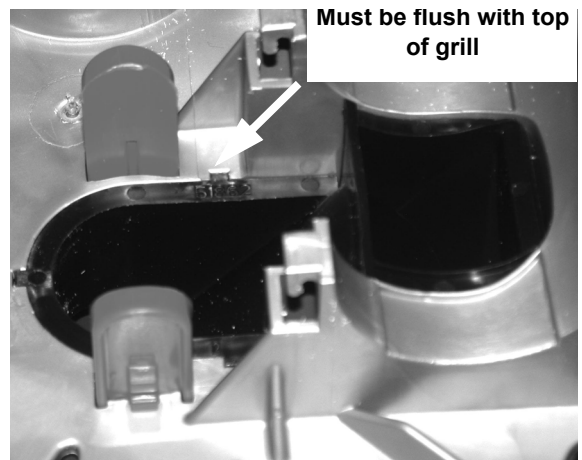
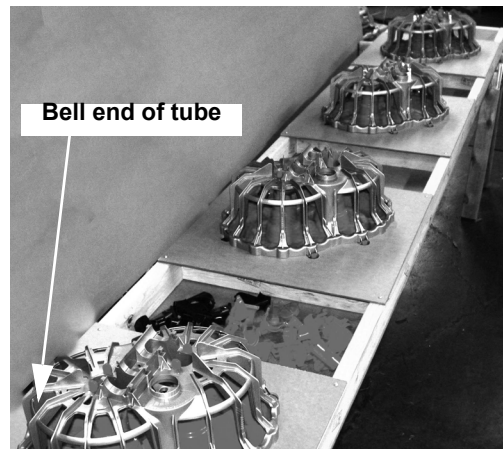
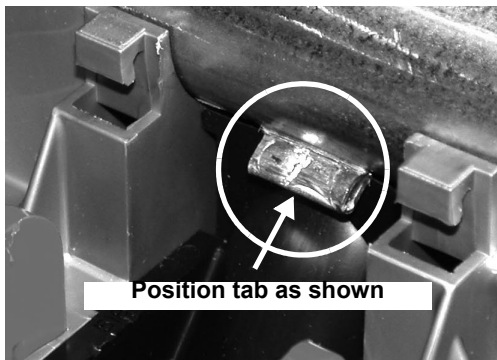


Figure 37.

3. Install the feeder tube to the feeder pan assemblies.



4. Install two support caps over the feeder tube.

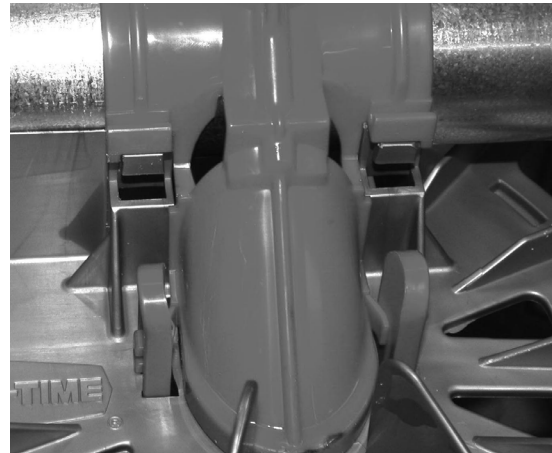
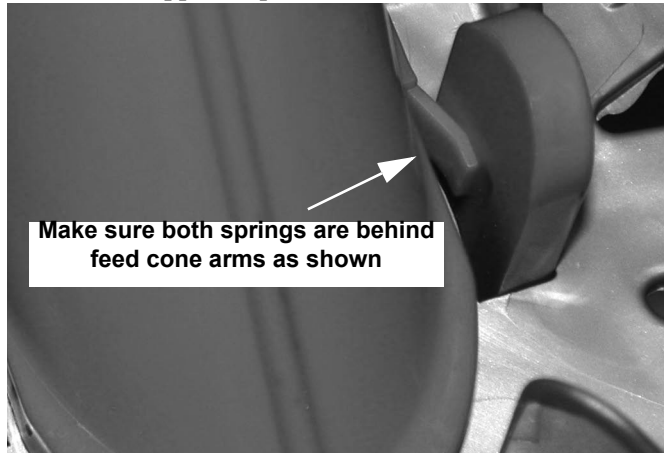
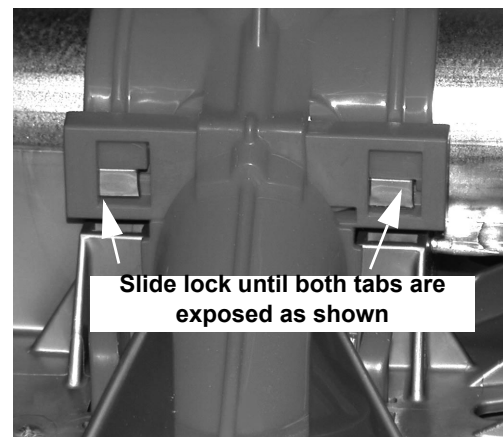
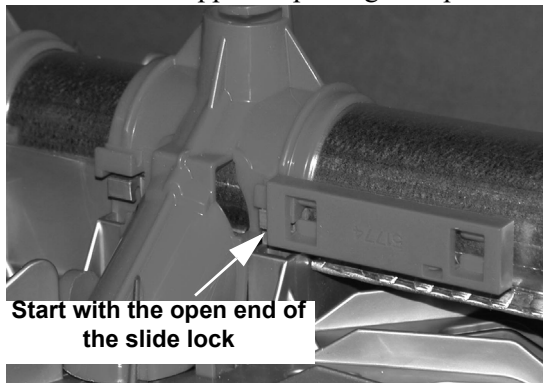
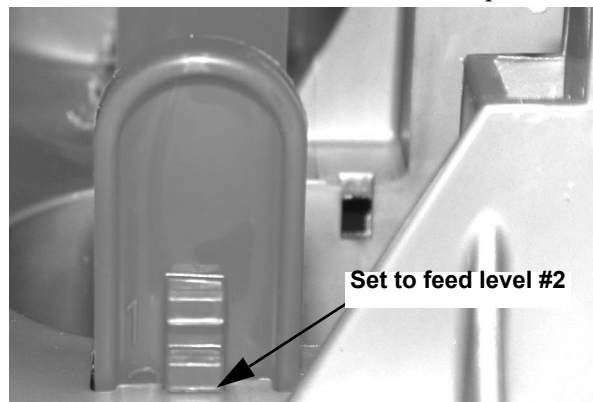


Figure 38. Support Cap Installation

5. Install four slide locks per pan. Start the open end of the lock to slide over the support cap and grill top.



6. Be sure all feed level cones are set to #2 position



7. Remove the tube assembly from the fixture and continue assembling the remaining feeder pans and tubes.

#### ASSEMBLY CHECK LIST:

1. All pans have two feed cones and feed gates, see page 25.
2. All feed cones set on #2 setting, see page 28.
3. All four pan snaps are snapped in properly, see page 25.
4. All pans are installed in the correct direction, see page 27.
5. All pans have two feed shuts installed, see page 27.
6. All pans have two support caps installed, see page 28.
7. Springs are behind feed level cones arms, see page 28.
8. Slide lock is installed with two tabs showing, see page 28.

# Assemble and Suspend the Feeder Line

1. The auger tubes and feeders may be laid out end to end in approximately the final location of the line. **The belled end of each tube should be toward the hopper end of the line,**
2. Connect the individual feeder tubes together by inserting the straight end of one tube as far as possible into the belled end of the next tube. **The last feeder tube before the end control or mid-line control pan needs to be a control tube.**

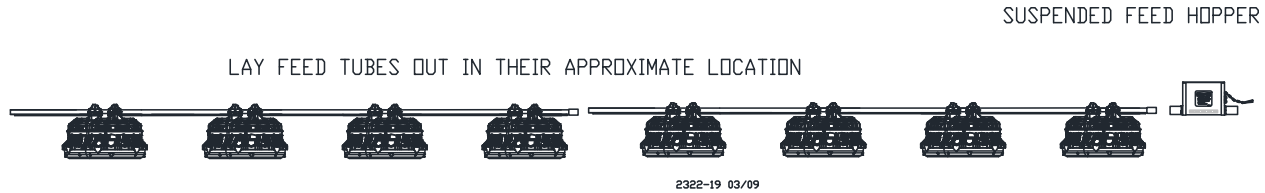


Figure 39. Assembling Feeders on the Tubes

3. To achieve total feed drop out all along the system, the Chore-Time logo should be centered at the crown of the tubes and all the hangers should be installed as shown in **Figure 40.**
4. Beginning at the boot place a tube clamp assembly or clamp/anti-roost bracket at each joint. **Figure 41** shows the standard clamp and clamp/anti-roost bracket.

Systems using 10' tubes require a clamp/anti-roost bracket every fifth joint. All other joints in the system use a standard tube clamp assembly.

Systems using 12' tubes require a clamp/anti-roost bracket every fourth joint. All other joints in the system use a standard tube clamp assembly.

5. Continue down the entire length of the feeder line so that every joint is secured with a standard clamp or a clamp/anti-roost bracket. **Figure 42** shows the proper clamp location on the tube joint. **Do not tighten the clamps at this time.**

6. Install the hangers on the feed line tube at 8' [2.4 m] spacings determined by the suspension drop lines. **Figure 40** shows the proper installation of the hanger assembly. Make sure the outlet drop hole is downward when the hangers are installed, otherwise feed will not be allowed to drop into the feeder pan.

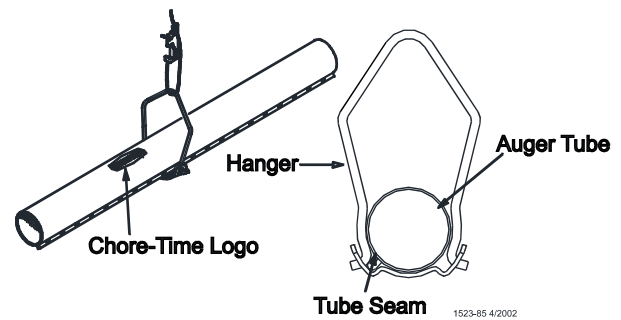


Figure 40. Hanger Installation

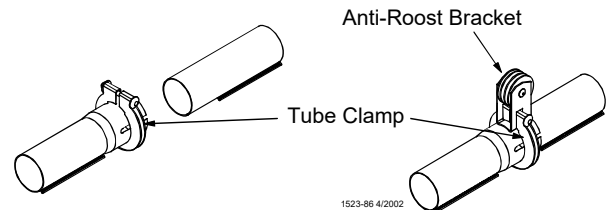


Figure 41. Tube Clamp & Clamp/Anti-Roost Bracket

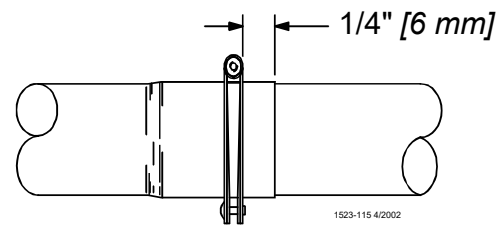
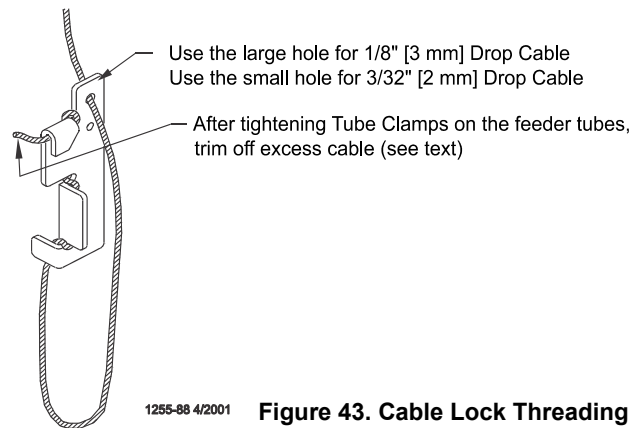


Figure 42. Clamp Installation

7. Install adjustment leveler within 6" [152 mm] of feeder line. **Figure 43** shows the proper cable routing around the adjustment Leveler.
8. Following the installation of all drops, check drop cables before raising feeder line. Cable must be tracking properly on all pulleys before raising the feeder line.
9. Rise the feeder line to a convenient working height.
10. With the feeder line suspended, measure from the floor or ceiling to the auger tubes to level the system.
11. Before tightening each clamp:

- Make sure each tube is level (not sagging, sloping, etc.).
- Make sure straight end of each tube is fully inserted in belled end of next tube.
- Tubes should be rotated so that the Chore-Time logo is on crown of tube.
- Make sure the clamps are located, as shown in **Figure 42**.

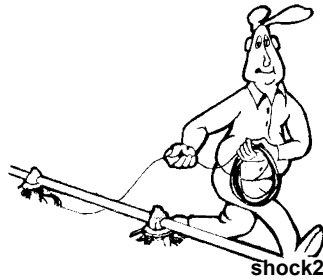
Tighten the tube clamps on the feeder tubes. Clamp the joints securely, but do not crush the tubes. Re-adjust all adjustment levelers as needed and trim off excess cable as shown in **Figure 43**.



**Figure 43. Cable Lock Threading**

# Anti-Roost Installation

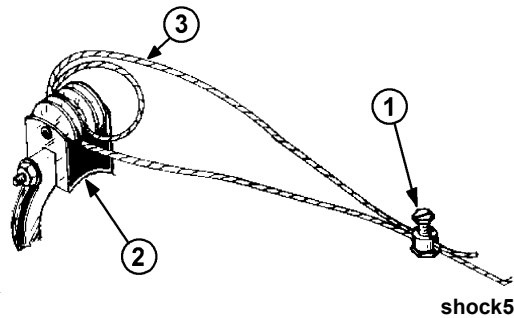
1. Unroll the bulk anti-roost cable. Note: If the cable is unrolled as shown in **Figure 44** taking 5 loops of the coil with one hand, then changing hands to remove 5 loops as it is unrolled, it will lie flat during installation.



**Figure 44. Unrolling the Cable**

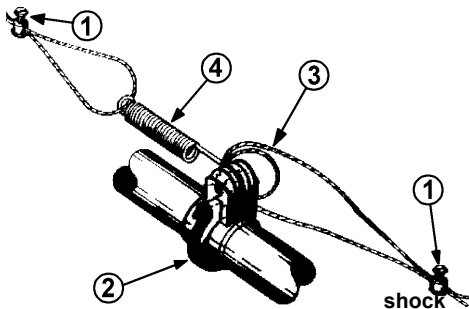
2. Start at the hopper end of the line and form a loop around the anti-roost bracket. For best results, make a double loop around the anti-roost insulator in the center groove of the insulator and fasten with a 1/16" cable clamp as shown in **Figure 45**.

Key	Description
1	Cable Clamp
2	Clamp with Insulator Bracket and Insulator
3	Anti-Roost Cable



**Figure 45. Anti-Roost Cable at the Hopper**

3. Insert the cable in the insulator on the top of each Grill Support between the hopper and the next anti-roost bracket.
4. Attach a spring in the center groove at the second anti-roost bracket and cut the cable at this point. Thread the ends of the cable through the end of the spring. Pull the cable tight so that there is 3/4" to 1" (20 to 25 mm) of stretch in the spring. Clamp the cable to form a loop and cut off any excess.
5. Attach the cable to the insulator. For best results, make a double loop around the anti-roost insulator in the center groove of the insulator and fasten with a 1/16" cable clamp as shown in **Figure 46**.



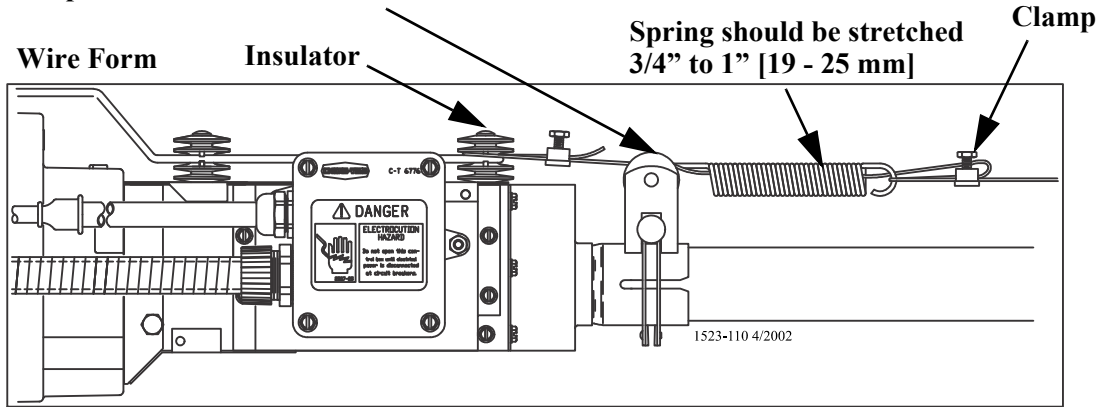
Key	Description
1	Cable Clamp
2	Clamp with Insulator Bracket and Insulator
3	Anti-Roost Cable
4	Spring should be stretched to 3/4" to 1" (19 to 25 mm).

**Figure 46. Anti-Roost Cable Mid-Line Connection**

6. Run the cable to the next insulator, attach a spring in the center groove at the anti-roost bracket and cut the cable at this point. The cable should be positioned in the insulator built into the top of each grill support along the feeder line.
7. Repeat this installation until the anti-roost cable is installed along the entire feeder line.

8. Install the wire form on the control unit insulators. Be sure the guard snaps into the retainers molded into the insulators. At the control unit, after clamping the cable to the spring, cut the cable about 8" to 10" [200 to 250mm] longer than necessary. Feed the end of the cable through the center of the spring, around the first insulator on the control unit, and clamp the cable using the cable clamp supplied with the control unit. Anti-

**Clamp with Anti-Roost Bracket and Insulator**



**Figure 47. Cable hook up at Power Unit.**

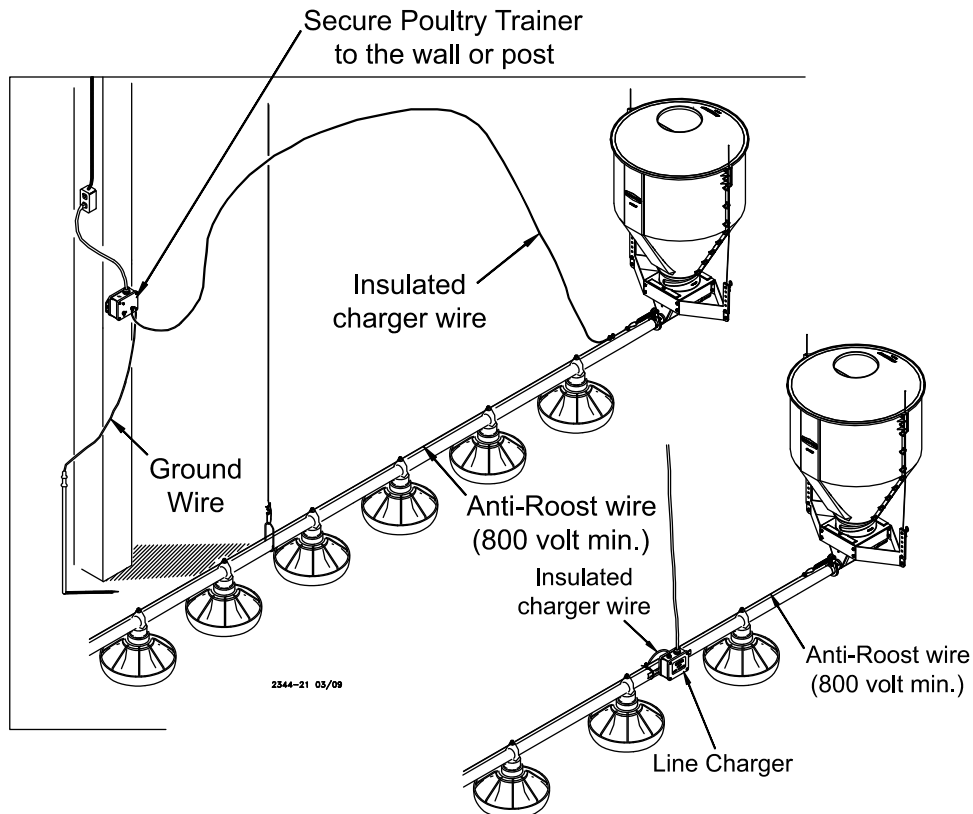
**Roost Installation at the Control Unit**

9. Install the Poultry Trainer or Line Charger, as shown in **Figure 48**.

The Poultry Trainer is used to power all Anti-Roost lines in a house. The Line Charger is used to power individual Anti-Roost lines in a house. Route the charger wire (800 volt minimum) from the Poultry Trainer or Line Charger to the Anti-Roost system. Secure the Charger Wire to the Anti-Roost cable, using a cable clamp.

10. The anti-roost system must be on a separate electrical circuit, allowing the system to be disconnected by a switch near the door.

Remember, the Anti-Roost System should be grounded through the poultry trainer.



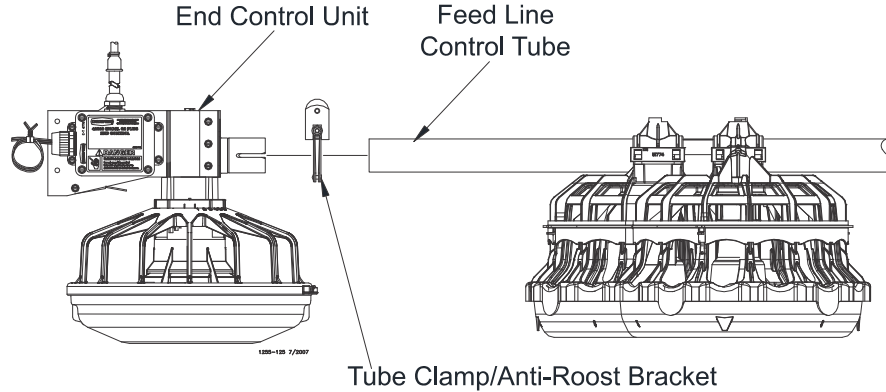
**Figure 48. Poultry Trainer Installation**



# End Control Installation

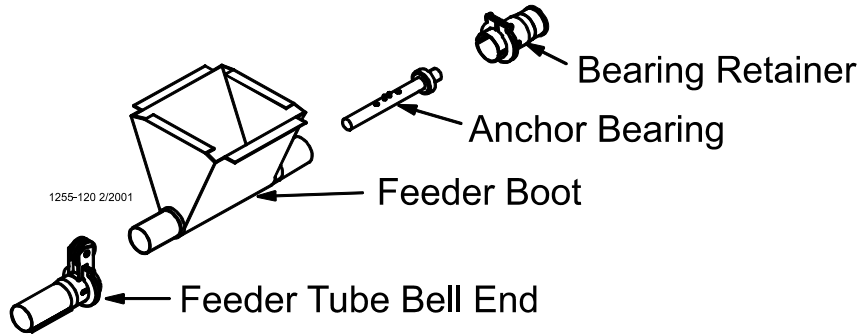
The End Control Unit must be at least 10 feet [3 m] from the end of the building to allow birds access around the end of the feeder line.

1. Assemble the End Control Unit to the Feeder Line Control Tube using a clamp/anti-roost bracket. See **Figure 49. DO NOT INSTALL THE POWER UNIT AT THIS TIME.**



**Figure 49. Connecting End Control Unit to the Feed Line Tube**

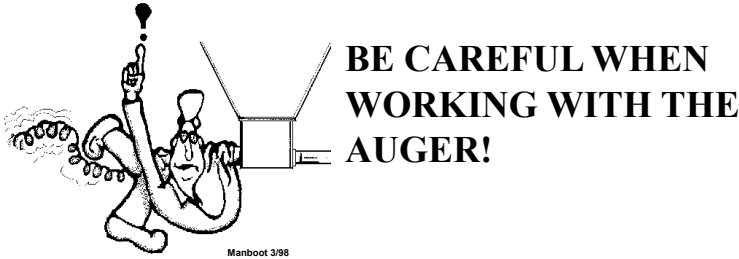
2. Install the Feeder boot by sliding the straight end of the Feeder Boot into the belled end of the Feeder Tube. Install a clamp/anti-roost bracket on the bell and tighten. The Feeder Boot must be level with the open top of the Feeder Boot flat. See **Figure 50. DO NOT INSTALL THE ANCHOR BEARING AND BEARING RETAINER AT THIS TIME.**



**Figure 50. Installing the Feeder Boot**

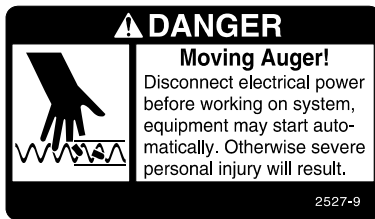
## Auger Installation

**Note:** Use extreme caution when working with the auger. The auger is under tension and may spring causing personal injury. Wear protective clothing, gloves, and safety glasses when working with the auger.

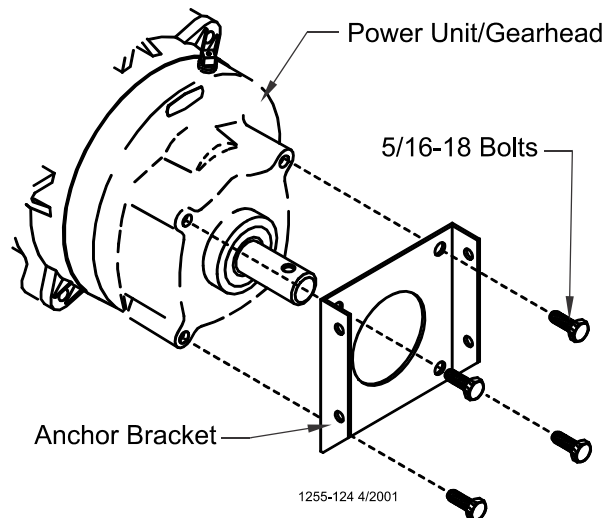


To avoid kinking the auger, be careful not to drop the rolled auger when handling. Inspect the auger carefully as it is installed. Small kinks may be straightened. Large kinks must be removed and the auger brazed back together.

Cut the leading 18" [450 mm] and last 18" [450 mm] off each roll of auger. Also, cut out any other distorted auger sections and reconnect the auger as specified in the Auger Brazing section of this manual.

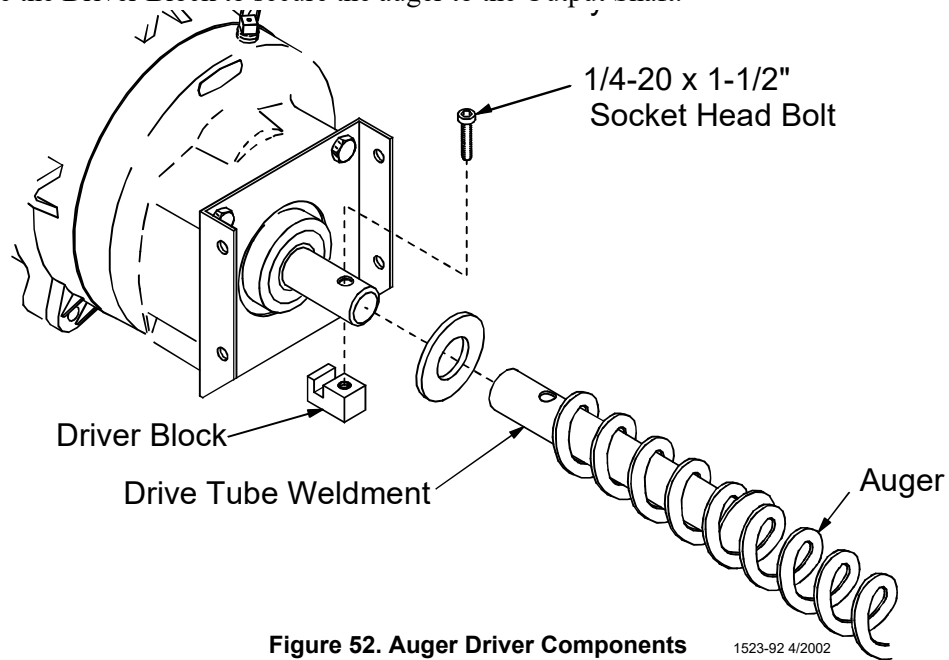


1. Use extreme caution when pushing the auger into the auger tubes. Keep your hand away from the end of the auger tube to avoid injury.  
With the auger coiled about 6 feet [1.8 m] from the end of the boot, uncoil the auger from the outside and feed the auger through the boot into the tubes.  
Push the auger into the tube in short strokes.  
Uncoil and handle the auger carefully to avoid damaging or kinking the auger.
2. If more than one coil is required for each feeder line, the auger ends will have to be brazed together. Refer to the Brazing the Auger section in this manual.
3. Install the Anchor Bracket to the Power Unit/Gearhead, as shown in **Figure 51.**, with the included 5/16-18 Bolts.



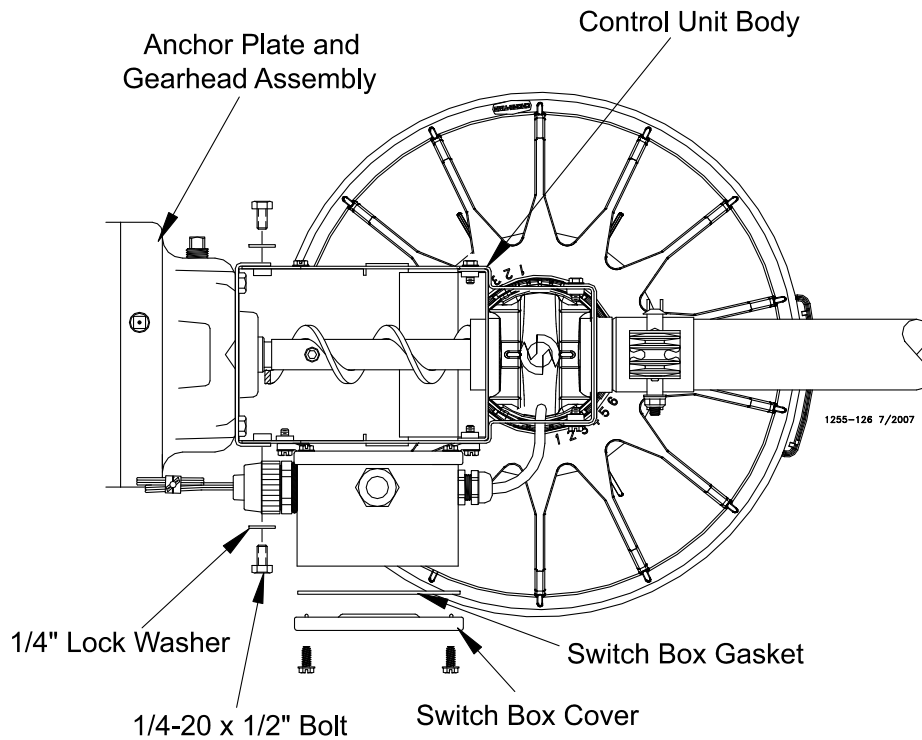
**Figure 51. Assemble the Anchor Bracket to the Power Unit/Gearhead**

4. Slide the Drive Tube and flat washer over the output shaft on the Power Unit, as shown in **Figure 52**.
5. Continue installing auger until the auger reaches the Control Unit end of the feeder line.
6. Turn the Drive Tube Weldment into the auger, then attach to the output shaft of the Power Unit, as shown in **Figure 52**. Use the Driver Block to secure the auger to the Output Shaft.



**Figure 52. Auger Driver Components** 1523-92 4/2002

7. Attach the Anchor Plate and Gearhead Assembly to the Control Unit Body using the included 1/4" Lock Washers and 1/4-20 x 1/2" Bolts. See **Figure 53**.



**Figure 53. Attaching the Anchor Plate and Gearhead Assembly to the Control Unit Body**

8. Install the Metal Water Tight Connector (**Item 1**) in the Feed Line Motor (**Item 2**). Cut the Flex Conduit (**Item 3**) to length. Slide the wires from the end control through the Flex Conduit (**Item 3**). Install the Flex Conduit (**Item 3**) in the connectors. Connect the wires to the Feed Line Motor (**Item 2**).

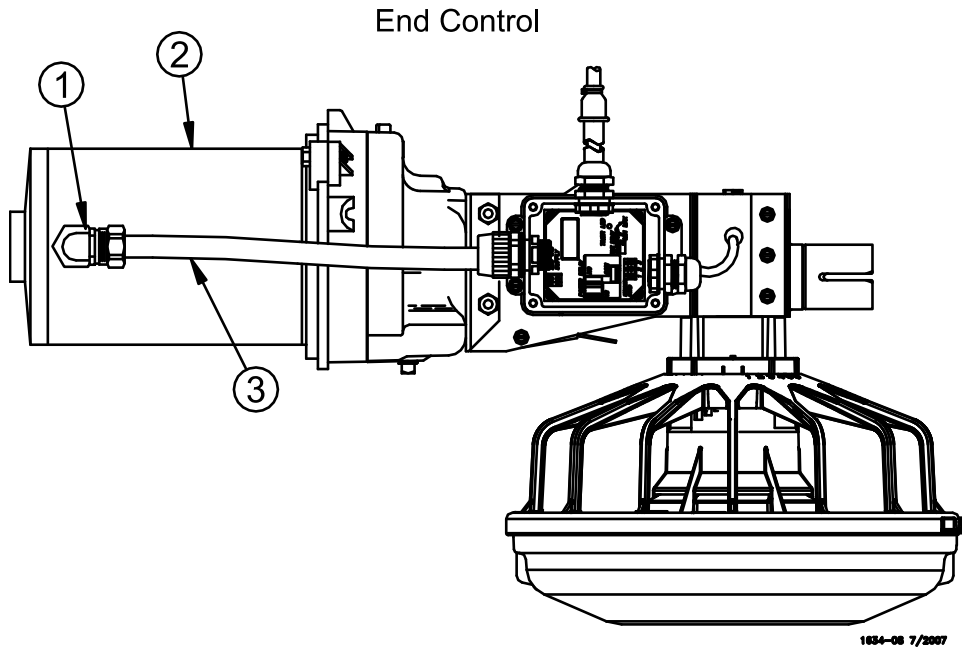


Figure 54. Wiring the Motor

9. Attach all covers and wire according to the wiring section of this manual.

10. Pull the auger at the boot end until it begins stretching. Then let it relax. In the *relaxed* position, mark the auger at the end of the boot. See **Figure 55**.

11. Auger stretch:

The auger needs to be stretched 7" [180 mm] per 100' [30 m]. Example: A 300' [90 m] feeder line requires 21" [500 mm] of stretch.

Beginning at the *relaxed* position, measure the required amount of stretch. Mark the auger at that point.

Grip the auger 8" [200 mm] ahead of this mark with locking pliers. Allow the auger to pull back into the boot so that the pliers rest against the end of the boot. See **Figure 56**.

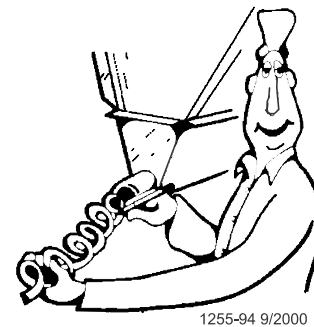


Figure 55. Measure the Auger from relaxed position

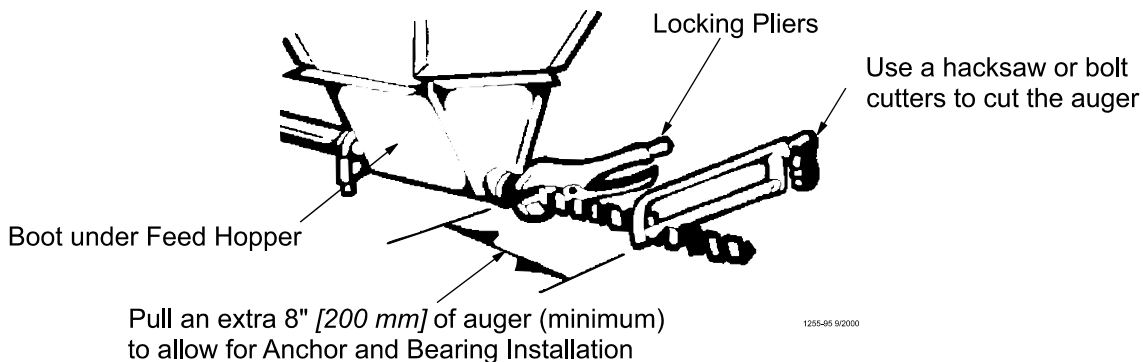
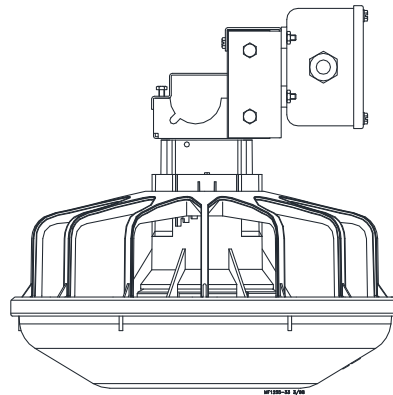


Figure 56. Cut Auger

# Mid-Line Control Installation

The Genesis® Straight-Line feeding system uses a Model C2® Plus mid-line control unit. The Mid-Line Control is shown in **Figure 57**.



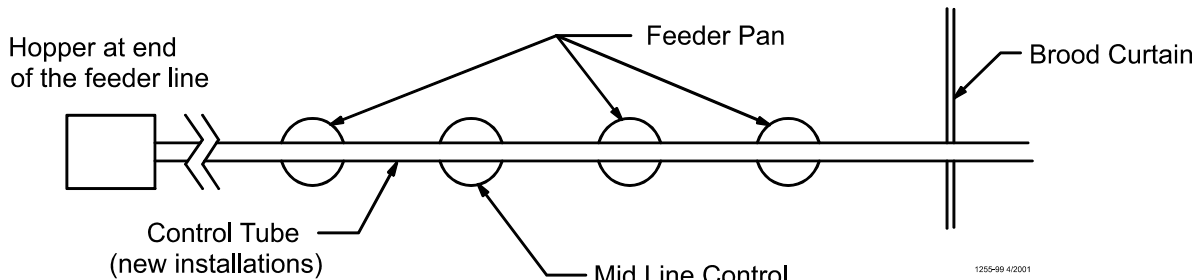
**Model C2 Plus Mid-Line Control with Mechanical Switch and Windows**

**Figure 57. Mid-Line Controls**

The Mid-Line Control makes it possible to operate the feeding system when birds are confined away from the End Control Unit. Chore-Time recommends placing the Mid-Line Control Feeder at least 2 pans away from the curtain or partition. See **Figure 58**.

1. **New Feeder Lines:** Leave one feeder pan assembly off the feeder control tube at the point where the Mid-Line Control needs to be placed. The feeder line can be assembled and suspended before attaching the Mid-Line Control; or the Mid-Line Control may be attached to the feeder tube when the other pans are installed.

**Existing Feeder Lines:** Cut the Grill Support and remove the feeder pan at the location where the Mid-Line Control will be installed.

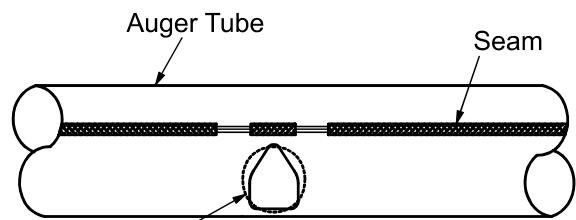


**Figure 58. Mid-Line Control Location Diagram**

2. **New Feeder Lines:** Go to step 3.

**Existing Feeder Lines:** Enlarge the outlet hole to approximately 1" [2.5 cm] diameter for the Mid-Line Control, plus enlarge (2) outlet holes in front (to the hopper end) of the Mid-Line Control.

Use unibit to enlarge hole size. Be sure there are no burrs inside the tube to catch the auger.



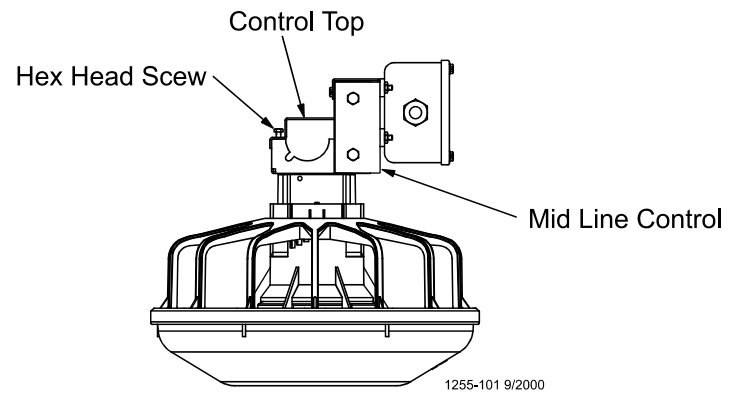
Use a Unibit to enlarge outlet holes on existing feeder lines

**Figure 59. Enlarging Outlet Holes**

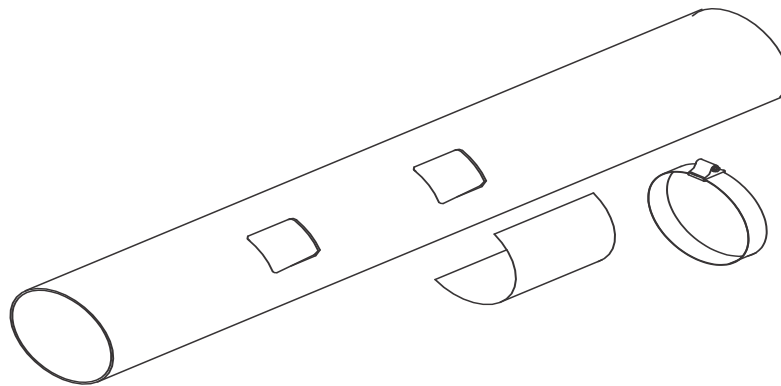
### 3. Install the Mid-Line Control:

#### **Mechanical Switch:**

- a. Remove the two hex head screws on the control top.
  - b. Lift off the control top.
  - c. Cradle the feeder tube in the control housing. The feeder tube may have to be turned slightly to allow the pan to hang straight.
  - d. Clamp the control in place by inserting tabs on the control top into the slots on the control body. Install and tighten the two hex head screws previously removed.
4. Add a tube closure kit when installing to close the extra hole.



**Figure 60. Mid-Line Control Installation**



**Figure 61. Tube closure installation**

## Feeder Management

This section Provides you with valuable information concerning feeder operation and management. It is important that you read this information and understand how the feeding system was designed to operate. Once you become familiar with the system, you may *custom operate* it to fit your individual needs.

### Initial Start-up of the GENESIS® Straight-Line Feeding System

The Feeding system should be operated prior to birds being housed to make sure the installation is correct, the switches function properly, and to fill the feeder lines with feed.

It is common practice to use partial house brooding during the early days of breeder pullet production. The GENESIS® Straight-Line pullet buildings typically have four feeder lines. Only the feeders in the brood area will be operated during brood time. The Genesis® Straight-Line Breeder building will have four feed lines.

The feeder tubes and auger are supplied from the factory with a protective oil coating that will cause the system to deliver feed at a reduced rate. The oil coating will also create a larger load on the power unit (motor) until the system has been cleaned of the oil.

### Feeding controls

The following controls may be used to supply start and run times. With time set on the timer controls, you may operate the feeder lines manually.

The GENESIS® Straight-line Feeding System may be controlled by any of the following controls. The 34380 Breeder Control Panel or the 50360 Breeder Control with the 50388, 8 Channel Timer. Refer to the instructions supplied with each control for information. The GENESIS® system may also be controlled by the CHORE-TRONICS® 2 with the breeder chip.

See the individual instruction manuals for operation information.

### Start up operation

1. Lower feeder lines so the feed pans are resting on the floor. Although the major weight of the feeder lines will be on the floor, do not remove all the weight from the suspension system and allow the suspension cables to become slack.
2. With time set on timer control, allow to operate empty for 2-3 minutes.
3. With the shut-off slide on the feed bin boot closed, energize the Flex-Auger® fill system. After operation of approximately 1-2 minutes, open the boot slide 1/2 way to allow feed to be conveyed to the feeders.
4. Once feed begins to be dispensed into the feeder boot(s), manually shut-off the fill system.
5. Apply power again to the feeder lines. Operate the fill system manually to dispense approximately 50 lb. [23 kg] increments of feed into the feeder boot(s). Allow the feeder boot to become empty for 30 seconds between each increment to reduce load on the feeder motor. Continue this procedure until feed has been dispensed to all the feeder pans. When the feed reaches the control pan, the feeder line will be shut-off.
6. Once the feeder lines have been initially filled with feed, manually dispensing feed in 50 lb. [23 kg] increments will no longer be necessary. The shut-off slide on the Flex-Auger® fill system may be completely opened. Refer to the Flex-Auger fill system Operator's Manual for information when multiple feed bins are used.

### General Operation of the GENESIS® Straight-Line Feeding system

**These recommendations are the guideline to aid producers with the use of the feeding system.** With experience a feeding program will be developed to enhance the feeding systems performance. Several factors such as feed content, type of birds, climate, lighting programs, and etc. may dictate change from these recommendations.

Chore-Time recommends running the fill system 3 to 5 minutes before running the feeder lines. The feeder lines should be run 7 to 10 minutes prior to the lights coming on in the house, to assure all feeder pans are equally charged prior to birds feeding.

## The GENESIS® Straight-Line Pullet Feeder

The pullet feeder has feed gates which allows the feeder pan, when gate is open, to be filled with feed for the brooding of young birds. Start young birds with the feeder line lowered so the feed pans are resting on the floor and the feed gates are completely open. Although the major weight of the feeder lines will be on the floor, do not remove all the weight from the suspension system and allow the cables to become slack.

It is advisable to provide supplemental feed during the first few days for the young birds. This is especially true when partial house brooding is used. Supplemental feeders such as the CHORE-TIME® E-Z START® Chick feeder, provide extra feeding space and access to feed.

With the feeders lowered to the floor and the feed gates open, the operation of the feeder will allow a high level of feed to be placed into the feed pans making it easy for the birds to find feed, adapt to the feeder, and begin to eat.

## The GENESIS® Straight-Line Breeder Feeder

The height and width opening on the feeder should be checked periodically. These settings will be determined by the bird company. (Example 44mm for width and 70mm for the height)

The scale feed amount will be determined by the bird service person.

## Feeder height and feed level

As the birds grow and become acclimated to the feeder pans, the feeder will need to be raised to the grow-out position. Before raising the feeder, it is recommended to allow the birds to eat the feed level down below the feed flood windows. This will ease the process of the feed flood windows closing properly.

The feeder height should be adjusted for breeder hens to the proper height for the bird age. See **Figure 64** for the most ideal setting.

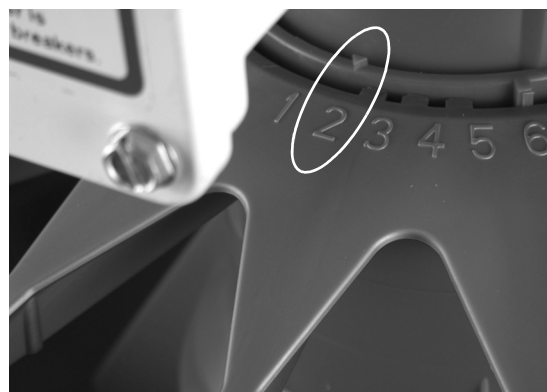
**The feeders should be set on the #2 feed position for pullet and hen applications. See Figure 62.**

**End controls and midline controls should be set on #2 feed position for pullet and hen applications, see**

Setting #2 will allow the feeding system to maintain a full charge in the tubes at all times with most feeds. Feed texture and consistency, type of bird, or other variables may make it necessary to change to another feed setting position. The combination of proper pan height, feeder setting, and feeder operation will result in optimum feeder performance (refer to **Figure 64** for pan height information). The operator will learn what performs best for his/her situation with experience.



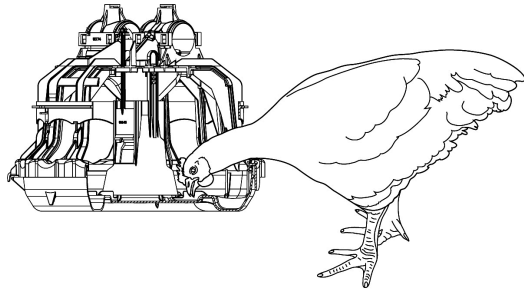
**Figure 62. Feed setting adjustment**



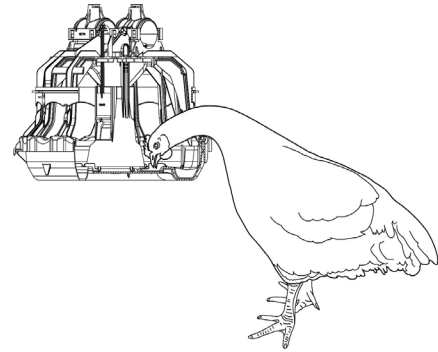
**Figure 63. Feed setting End/Midline control**



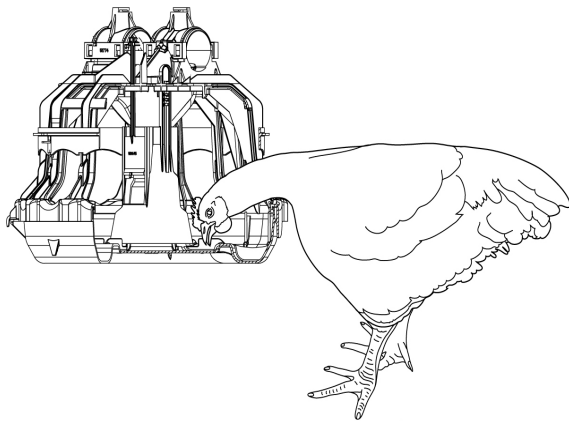
## Feeder Height Adjustment.



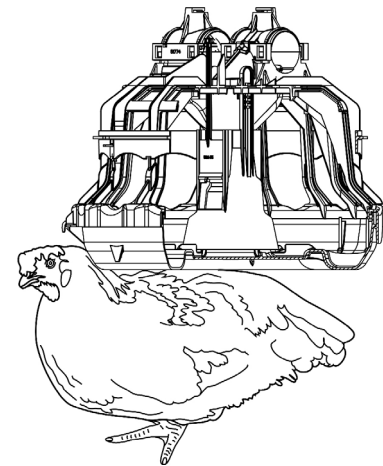
Feeder too LOW



Feeder too HIGH



Correct eating hight



Feeder too HIGH

**Figure 64. Feeder Pan  
Assembly height adjustment**

## Electro-guard Operation

The electro-guard chargers should be operated on a separate electrical circuit so the anti-roost system can be shut off using a switch next to the entrance door when someone enters the building. Birds are less likely to become wild and flighty if the anti-roost is off when people are in the building.

## Maintenance

The GENESIS Feeding System Feeders require minimum maintenance. However, a routine periodic inspection of the equipment will prevent unnecessary problems.

Maintenance should be done by a qualified technician.



**ALWAYS DISCONNECT POWER TO THE SYSTEM WHEN SERVICING OR MAINTAINING THE EQUIPMENT. FAILURE TO DISCONNECT POWER MAY CAUSE INJURY OR DEATH.**

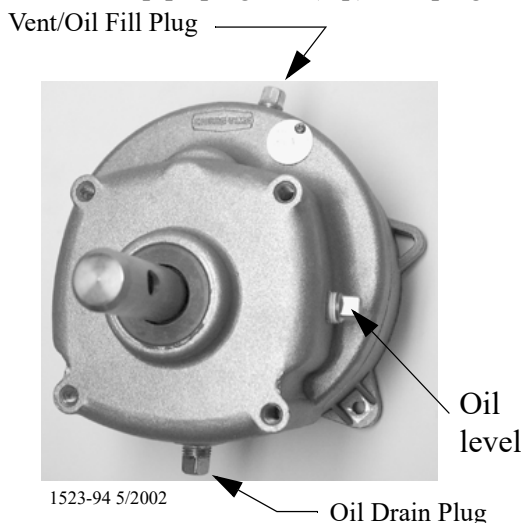
### Gear Head Maintenance

Refer to **Figure 65**.

Check the oil level in the gear heads at installation and every 6 months. The pipe plug, on the side of the gear head, indicates proper oil level. Add SAE 40W oil when necessary.

The oil in the gearheads should be replaced every 12 months with new SAE 40W oil

- A. Remove the bottom pipe plug to drain the oil. Discard used oil in accordance with local and national codes.
- B. Wipe any debris off the magnet on the bottom pipe plug and reinstall. Remove the side pipe plug and (top) vent plug.
- C. Set the power unit in the horizontal position.
- D. 2-Stage gearheads: Add approximately 9 oz. [266ml] of SAE 40W oil through top hole. This should be just enough oil to reach the side pipe plug.  
3-Stage gearheads (3261-9, 3261-12, 3261-14): Add approximately 13 oz. [384ml] of SAE 40W oil through top hole. This should be just enough oil to reach the side pipe plug.
- E. Install the side pipe plug and (top) vent plug.



- Check the oil level in the gear head at installation.
- Check the oil level every 6 months.
- Check the oil level at the side plug. If oil is needed, use SAE 40W oil.
- Oil capacity for the two stage gear head is 9 oz. [266 ml].
- Oil capacity for the three stage gear head is 13 oz. [384 ml].
- The oil should be changed every 12 months.

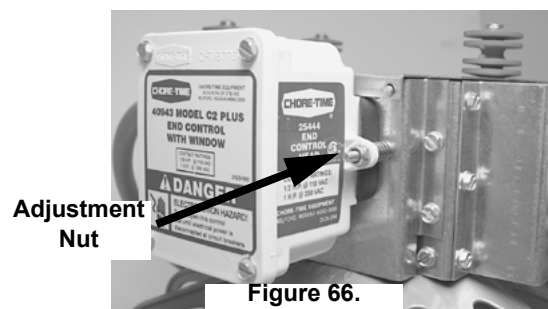
**Figure 65. Gearhead Maintenance**

Check equipment for loose hardware after the first flock and then every 6 months--including the Anchor Block. Tighten if necessary.

### Mechanical Switch Adjustment Procedure

Refer to **Figure 66**.

- A. Turn the adjustment nut counter-clockwise until the switch clicks.
- B. Turn the adjustment nut clockwise until the switch clicks.
- C. Turn the adjustment nut counter-clockwise 3/4 turn.



**Figure 66.**

## Feeder Line

Keep anti-roost cables tightly stretched. This increases the effectiveness of the electro-guard anti-roost system and keep the pans from being tilted when birds push against them.

Remove all feed from the feeder when there are no birds in the house and when the building is washed and disinfected.

Turn the feeders off prior to removing the birds from the house. This will allow them to clean the feed out of the pans.

If the system is not to be used for an extended period of time, remove all the feed from the feeder lines and feeder pans.

Disconnect power to the system to prevent accidentally starting the system.

If the system must be disassembled, extreme caution must be used to prevent injury from springing auger.

1. Disconnect power to the entire system.
2. Loosen the Tube Clamp on the bearing at the hopper end of the system. Remove the Tube Clamp and Bearing Retainer.
3. Pull the Anchor and Bearing Assembly and approximately 18" [45 cm] of auger out of the boot.

**CAUTION: Stand clear...the auger may spring back into the tube.**

4. Place a clamp or locking pliers securely on the auger to prevent it from springing back into the auger boot.
5. Loosen the setscrews in the bearing assembly shaft and remove the Anchor and Bearing Assembly from the auger.

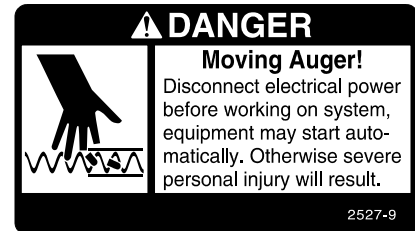
### To reinstall the Anchor and Bearing Assembly:

1. Insert the Anchor Assembly into the auger until it touches the washer at the back of the anchor. Tighten the setscrews in the center of the anchor until they touch the auger, then tighten a maximum of 1/2 turn. See **Figure 63**.
2. **Carefully** remove the locking pliers while holding onto the Anchor and Bearing Assembly and auger securely.

**Slowly** ease the auger back into the tube. Use caution.

If the auger is allowed to spring back, the bearing race may crack.

Install the Bearing Retainer and fasten with a tube clamp. Keep the Bearing Retainer flush with the end of the anchor for safety.

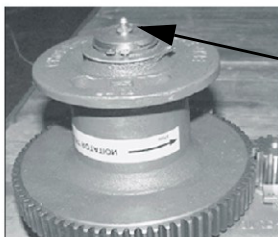


## Power Lift Winch Maintenance

Refer to **Figure 67**.

Grease the winch every 6 months with 1 to 2 shots of common industrial or automotive grease.

**DO NOT OVER GREASE THE WINCH.**



Grease the Power Lift Winch every 6 months with 1 to 2 shots of common industrial or automotive grease  
**DO NOT OVER GREASE THE POWER LIFT WINCH**

1000-249/2001

# Wiring

All electrical wiring must be done by a qualified electrician in accordance with local and national codes.

## Wiring Notes

Disconnect electrical power before inspecting or servicing the equipment, unless the maintenance instructions specifically state otherwise.

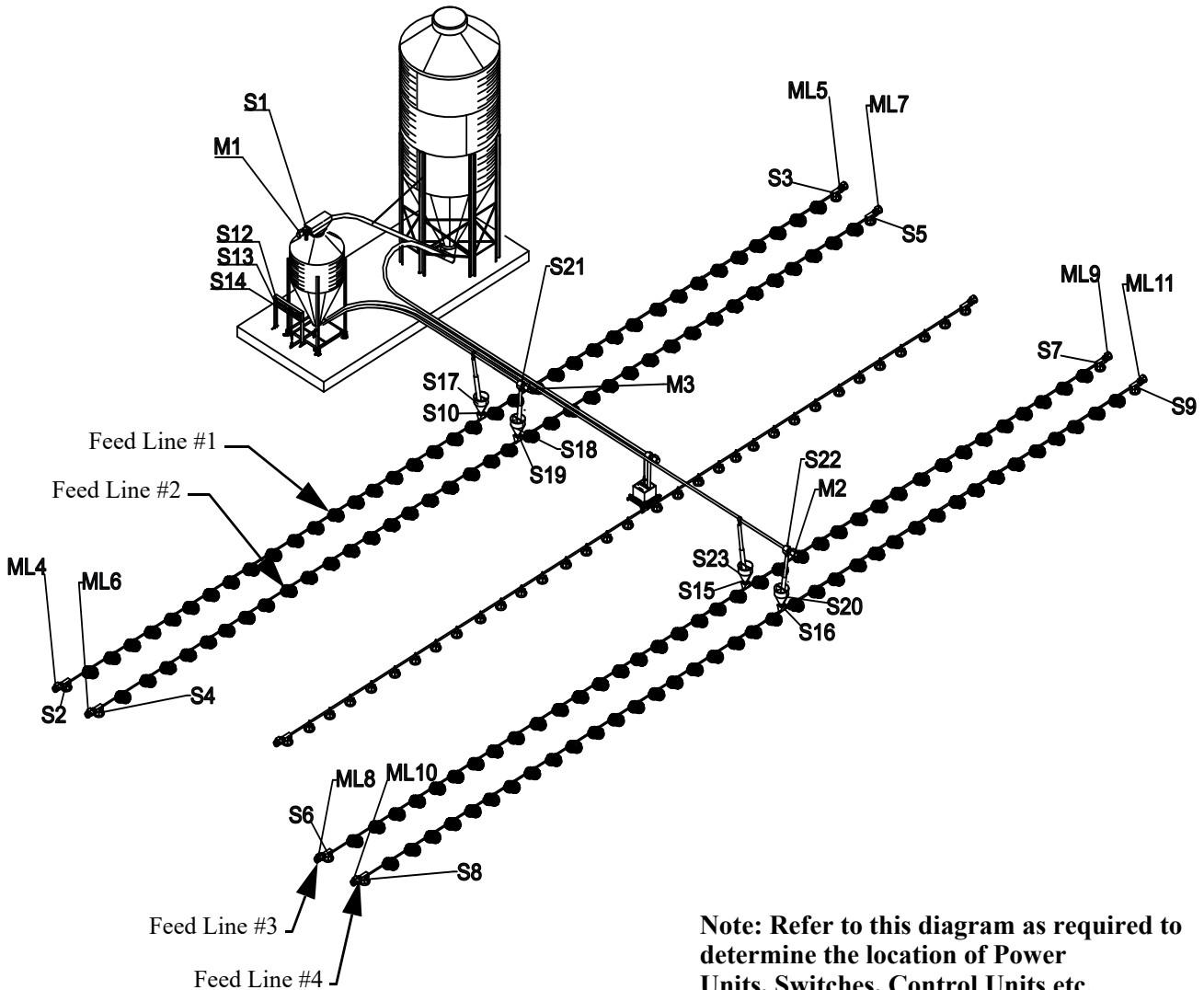
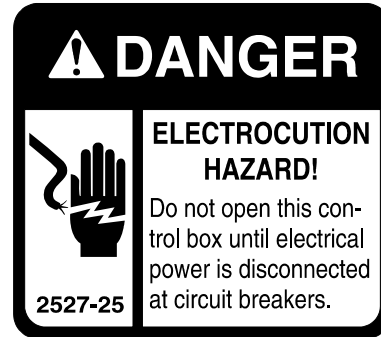
Wire the electrical equipment according to the wiring diagrams in this manual.

All field wiring must be done by a qualified electrician, according to local and national codes.

Do not operate the equipment without the covers and guards properly positioned.

Failure to do so may cause personal injury or damage to the equipment.

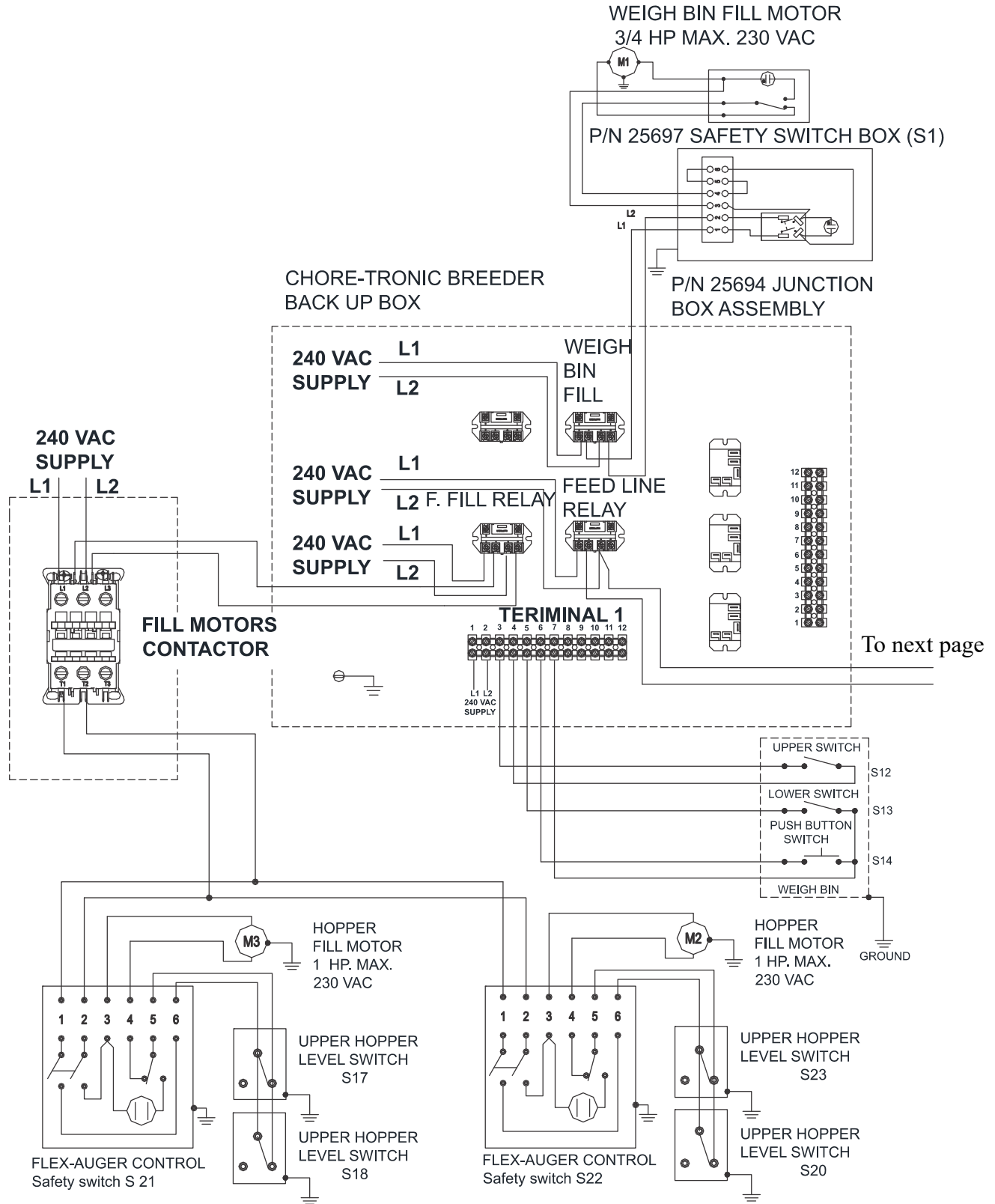
Ground all electrical equipment



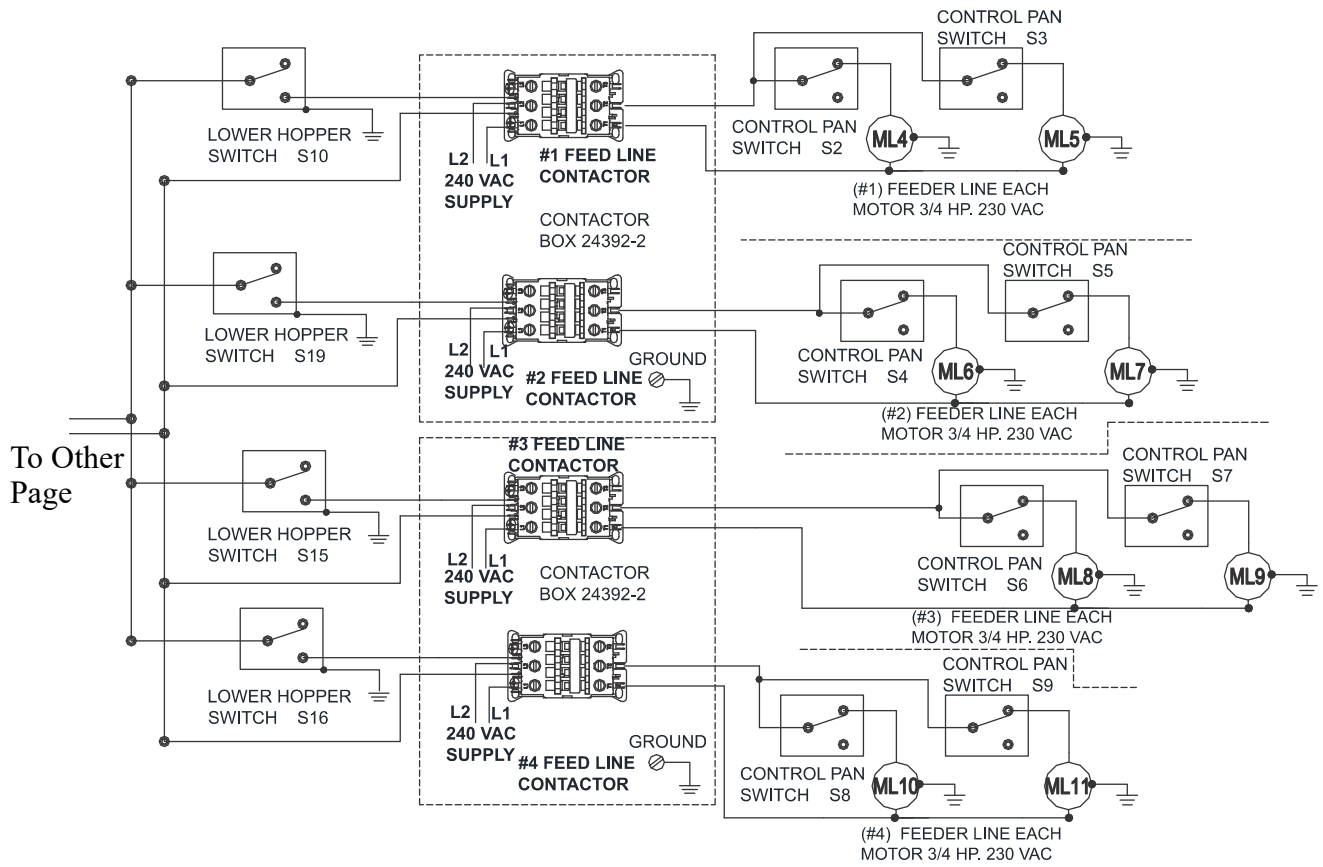
Note: Refer to this diagram as required to determine the location of Power Units, Switches, Control Units etc. Each component is coded with M1, S2, ML1 (Motor #1, Switch #2, Drive Unit #1).



# GENESIS® Feeder with CHORE-TRONICS® Control

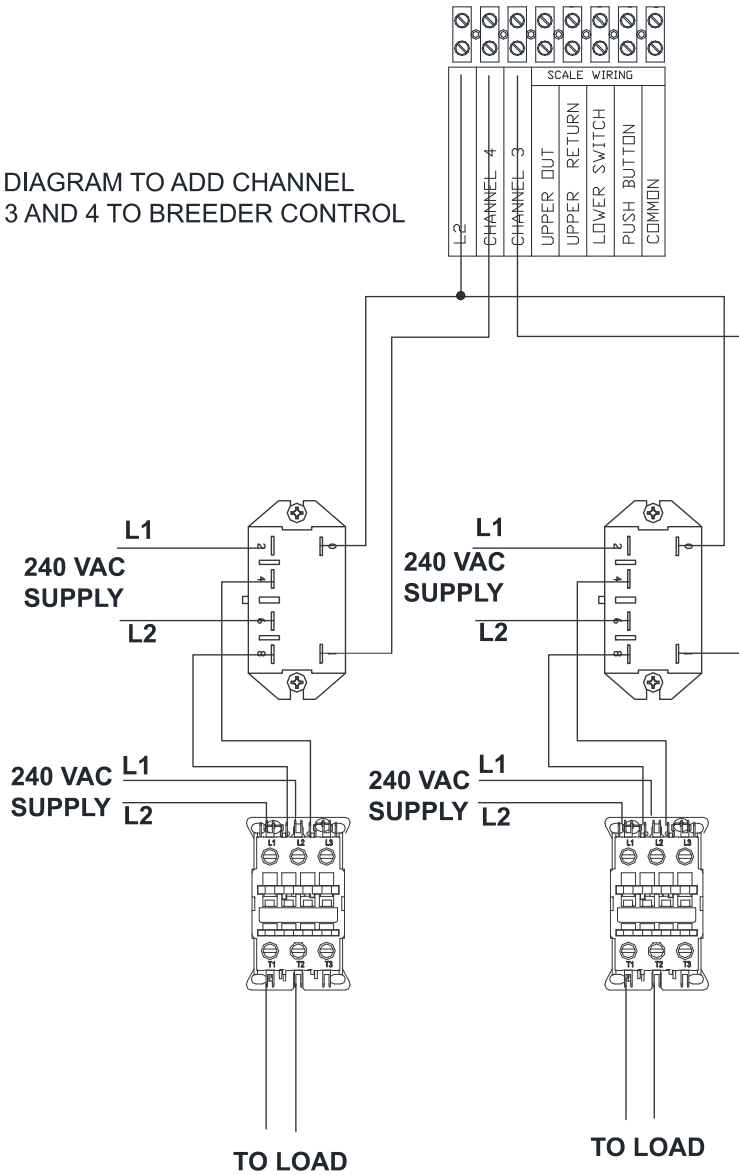


# GENESIS® Feeder with CHORE-TRONICS® Control



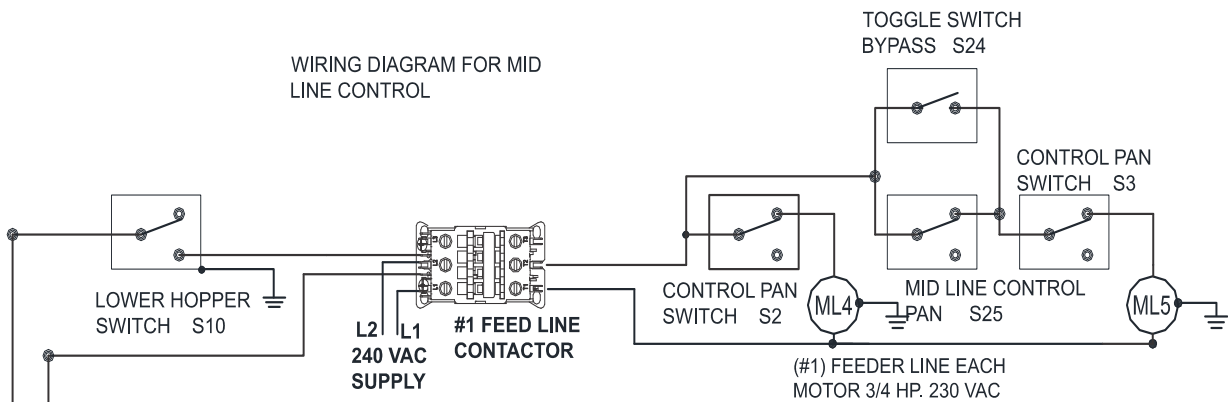
### Adding Channel 3 and 4 to 34380 Breeder Box

DIAGRAM TO ADD CHANNEL 3 AND 4 TO BREEDER CONTROL



### Adding MID LINE Control to Pullet Feeder

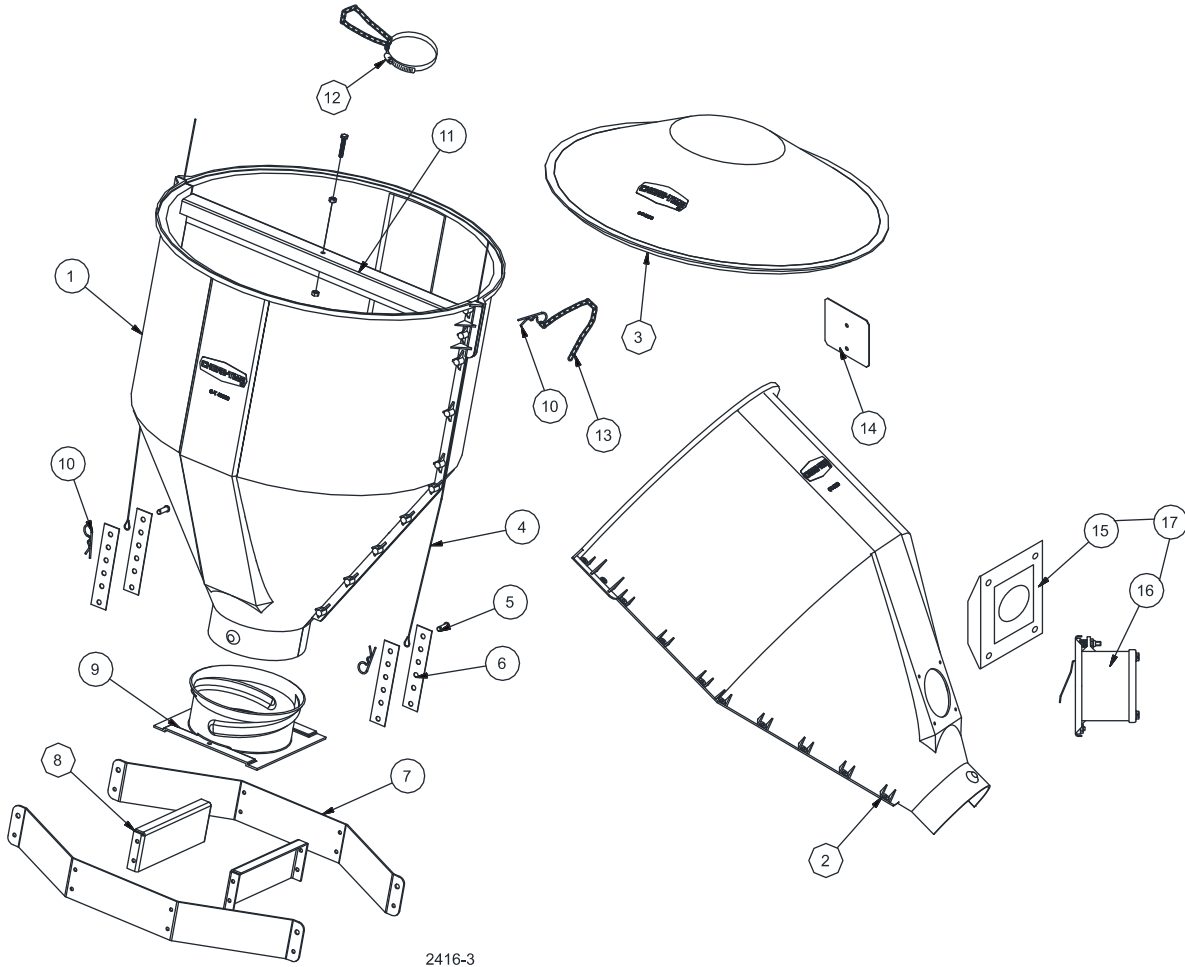
WIRING DIAGRAM FOR MID LINE CONTROL





# Parts List

## 150# Plastic Hopper



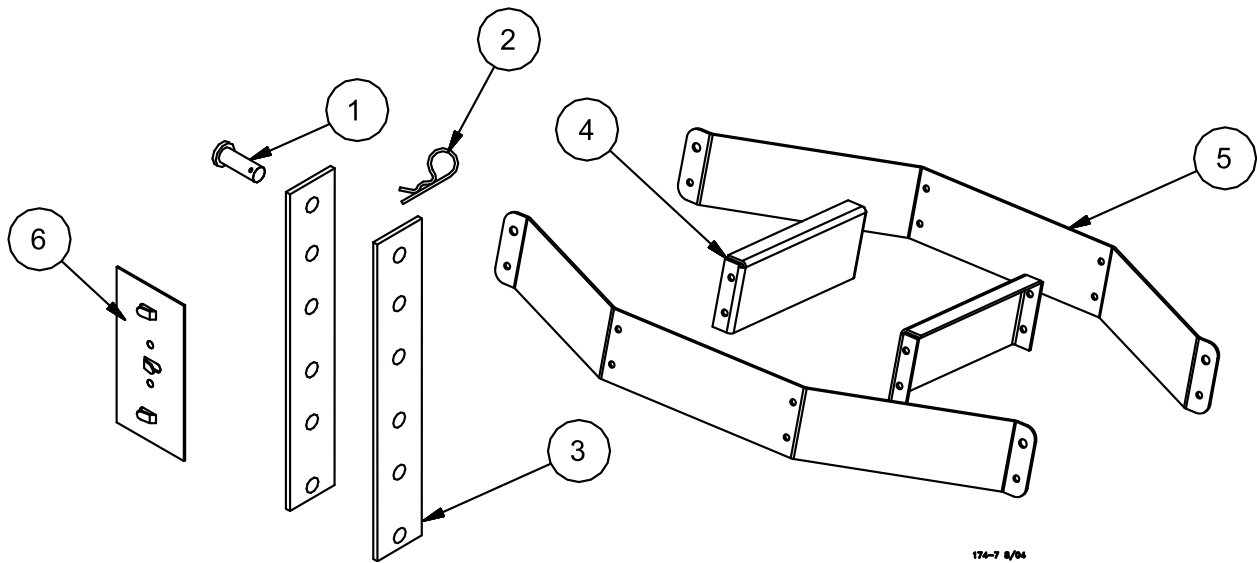
2416-3

### Hopper kit w/cover and switch 49268

Item	Description	Part No.
1	Hopper kits	48926
2	Plastic hopper half	49028
3	Hopper cover	48675
4	Support cable assembly	2809-3
5	Clevis pin	2797-1
6	Boot adjuster bracket	2706
7	Suspension angles	48679
8	Suspension brace	48680
9	Twist lock collar	49041
10	Hair pin	2664
11	Cross brace	49029
12	Drop tube support	14367
13	Chain 6 inch	2128
14	Switch mount reinforcer	50966
15	Diaphragm for 8798	7900
16	Switch Assembly	7840
17	Lower Hopper Switch	8798

### Hopper Boot Suspension Bracket (optional)

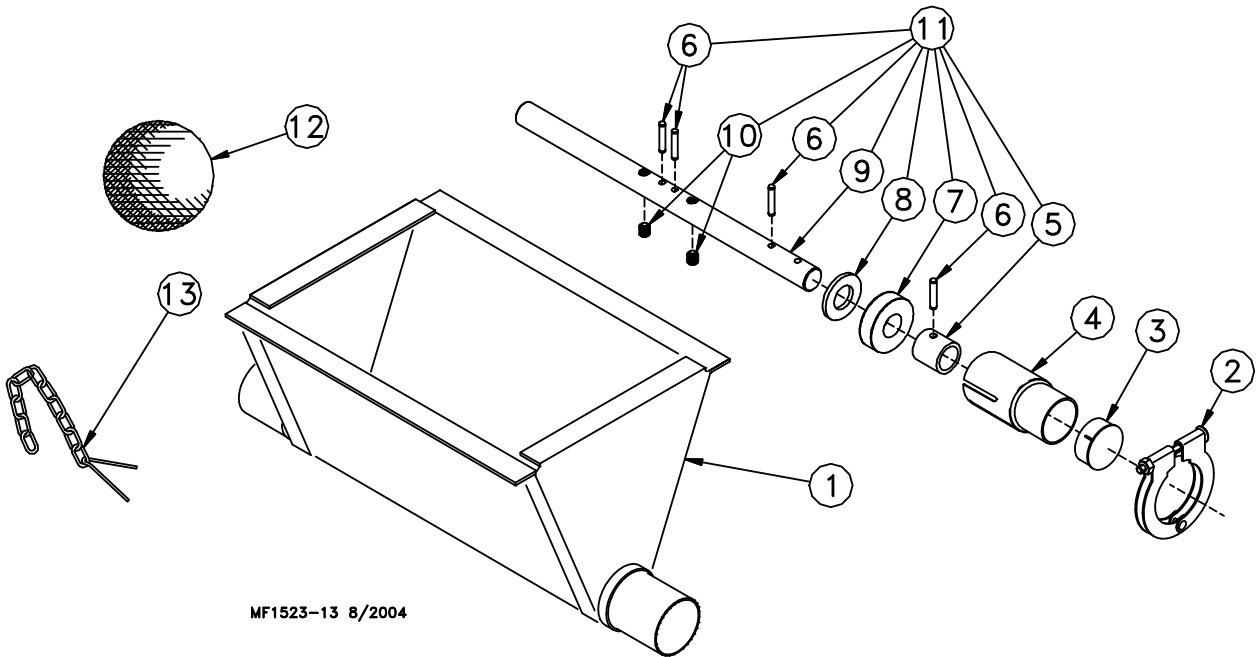
### Single and Twin Boot Hopper Support Kit: Part No. 49358



This kit is used to suspend steel hoppers.

Item	Description	Part No. Single Boot Kit	Part No. Twin Boot Kit
1	Clevis Pin, 5/16" x 1"	2797-1	2797-1
2	Adjustment Bracket	2706	2706
3	Hair Pin	2664	2664
4	Suspension brace	48680	48680
5	Suspension angles	48679	48679
6	Cable guides	34573	34573

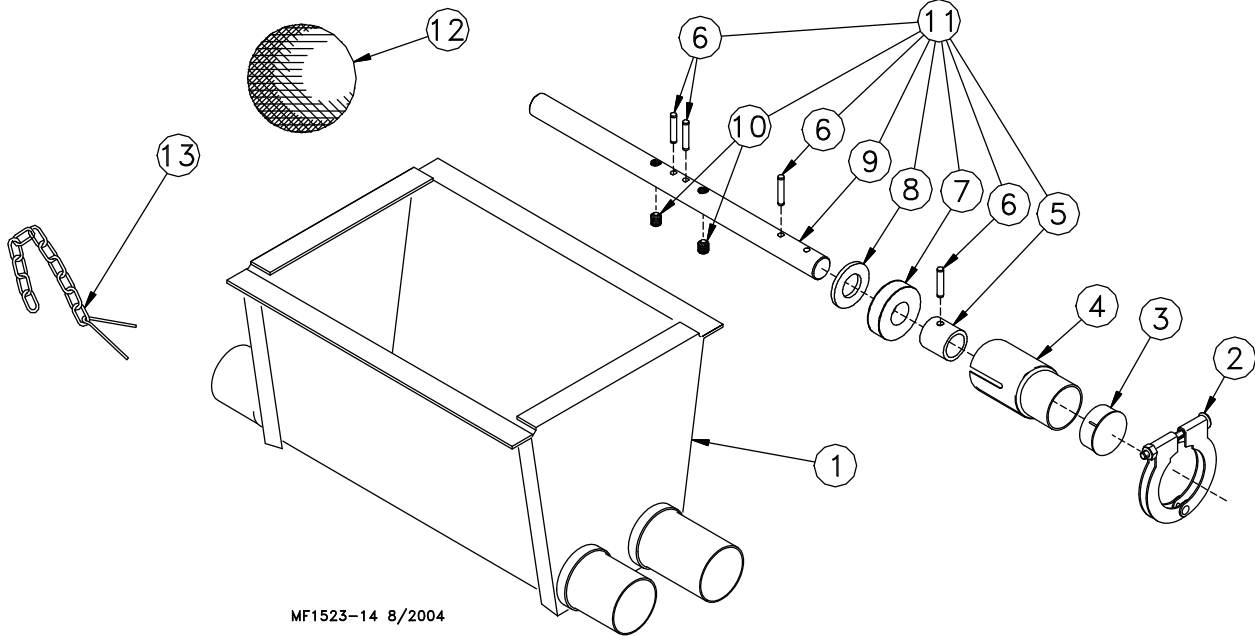
# Single Boot Components Part No. 6822



Item	Description	Part No.
1	Boot Weldment	3760
2	Tube Clamp	24063
3	Cap	29373
4	Outlet Tube	4556
5	Sleeve	5648
6	3/16 x 1" Pin	2960-1
7	Bearing	2689
8	Washer	2955-14
--	Danger Decal	2527-9

Item	Description	Part No.
9	Anchor	38540
10	5/16-18x7/8" Sock Hd Screw	47867
11	Anchor and Bearing Ass'y	39372
12	Cannonball	3531
13	Chain	2128-1
14	Cotter Pin	1639
15	Latch Pin Ass'y	2683
16	Washer	2955-58

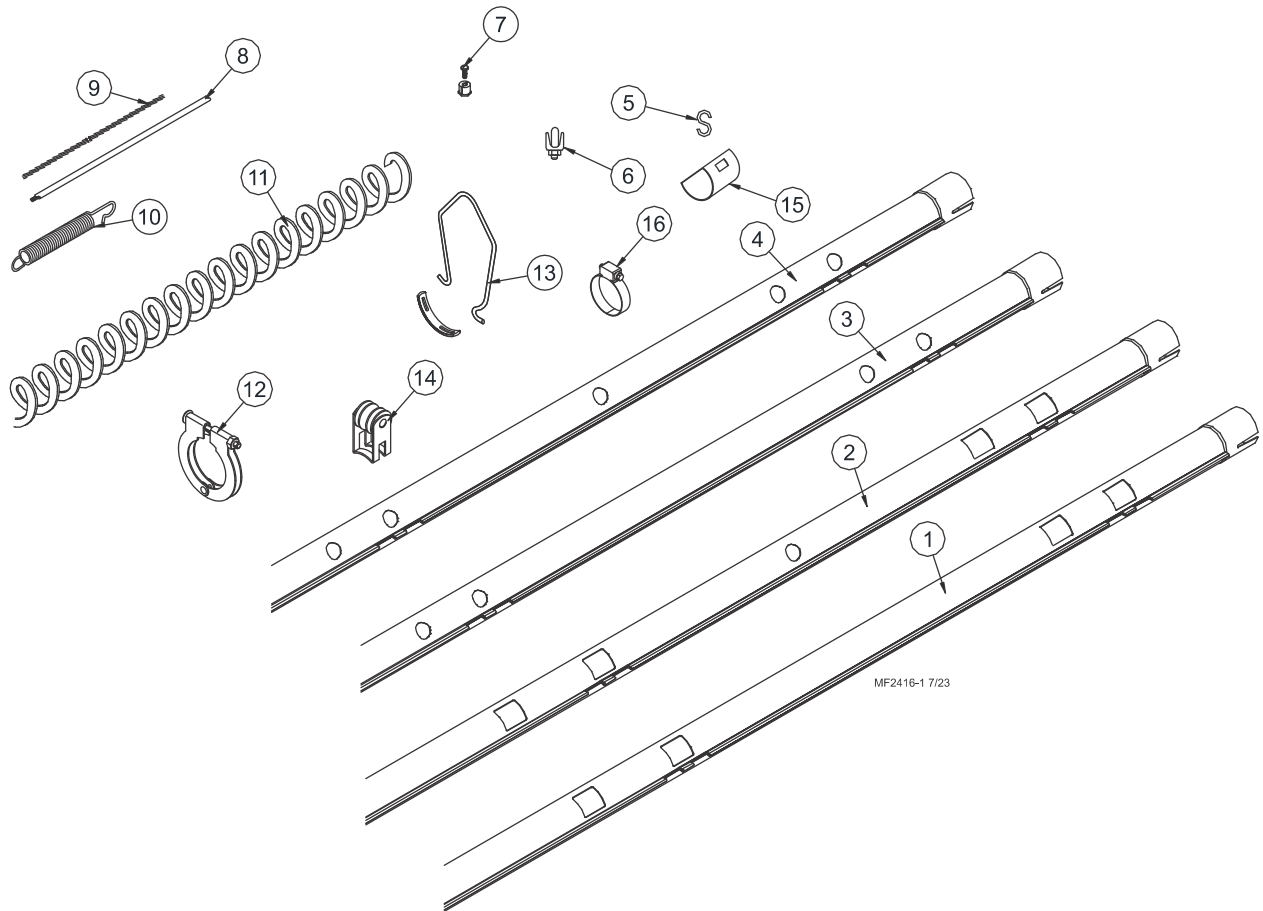
### Twin Boot Components Part No. 6824



Item	Description	Part No.
1	Boot Weldment	3760
2	Tube Clamp	24063
3	Cap	29373
4	Outlet Tube	4556
5	Sleeve	5648
6	3/16 x 1" Pin	2960-1
7	Bearing	2689
8	Washer	2955-14
--	Danger Decal	2527-9

Item	Description	Part No.
9	Anchor	38540
10	5/16-18x7/8" Sock Hd Screw	47867
11	Anchor and Bearing Ass'y	39372
12	Cannonball	3531
13	Chain	2128-1
14	Cotter Pin	1639
15	Latch Pin Ass'y	2683
16	Washer	2955-58

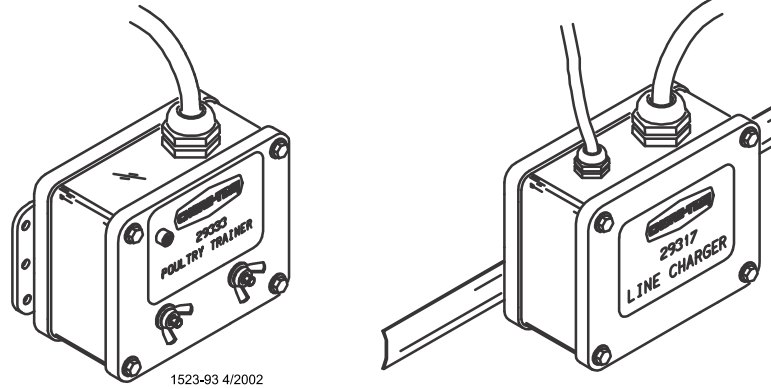
# Feeder Line Components



MF2416-1 7/23

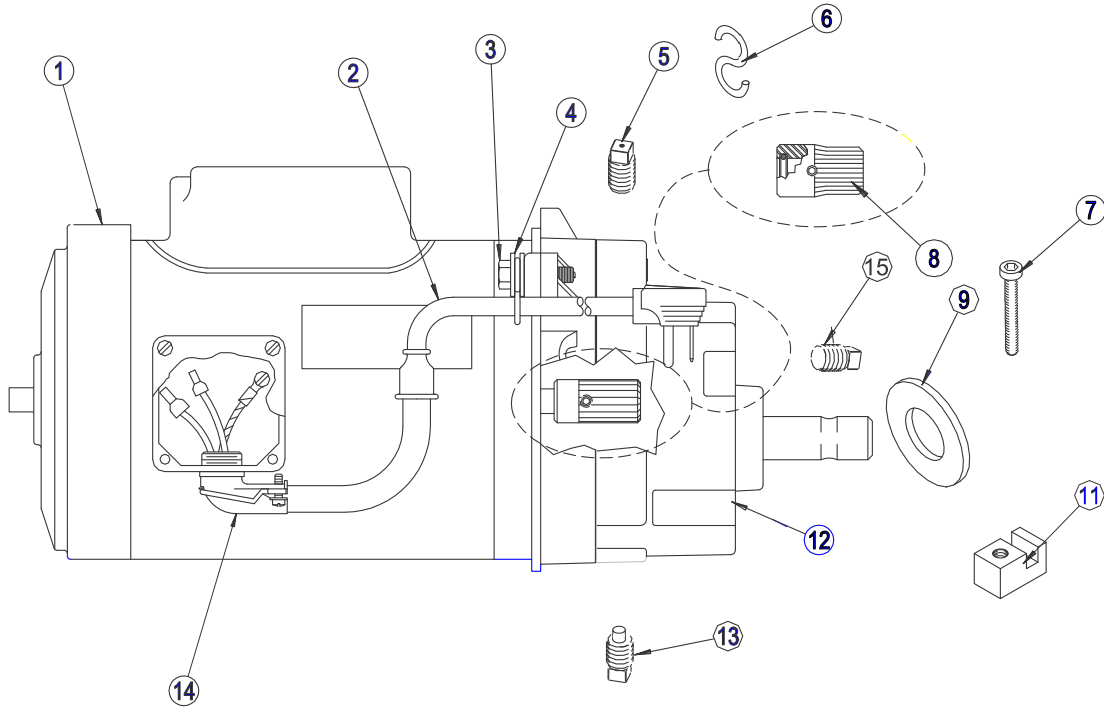
Item	Part No	Description	Item	Part No	Description
1	53865-1	10 Ft. 4 HI Control tube	2	53865-4	10 Ft 4 HI w/EZ hl Cntl tube
	53865-2	12 Ft. 4 HI. Control tube		53865-5	12 Ft 4HI w/EZ hl Cntl tube
	53865-3	10 Ft. 3 HI Control tube		53865-7	10 FT 3 HL W/EZ Cntl Tube
	53865-6	12 Ft 3 HI Control tube		53865-8	12 FT 3 HL W/EZ Cntl Tube
3	50830-1	10 Ft. 4 HI. Genesis tube	4	50830-4	10 Ft. 4 HI. Gen tube w/EZ
	50830-2	12 Ft. 4 HI. Genesis tube		50830-5	12 Ft. 4 HI. Gen tube w/EZ
	50830-3	10 Ft. 3 HI. Genesis tube		50830-7	10 FT 3 HL GEN tube w/EZ
	50830-6	12 Ft. 3 HI. Genesis tube		50830-8	12 FT 3 HL GEN tube w/EZ
5			6	14898	Cable Clamp
7	1826	Small Clamp	8	28994-330	Hi Voltage Wire
9	1922	1/16" Cable	10	7551	Anti Roost Spring
11	6820 WM	Auger	12	24063	1.75 Tube Clamp
13	51763	Tube Hanger	14	24060	Insulator Bracket
15	9126	Tube Closure	16	3527	Hose clamp
	14585	Hole closure kit			

## Poultry Trainer and Line Charger



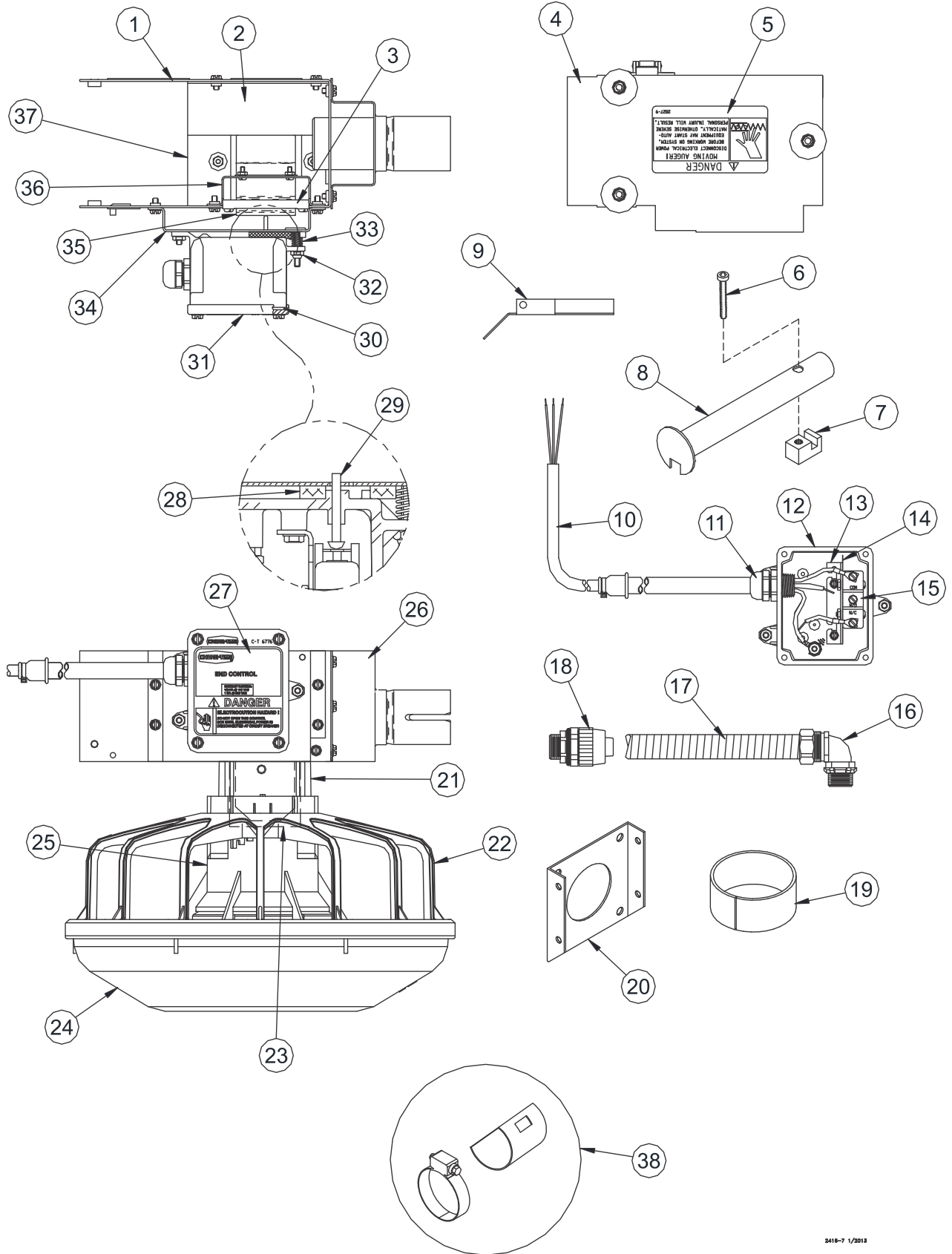
Description	Part No.
Poultry Trainer (110 V, 60 Hz.)	29333
Poultry Trainer (220 V, 50/60 Hz.)	29325
Line Charger (110 V, 60 Hz.)	29317
Line Charger (220 V, 50/60 Hz.)	29341

# Power Unit Assembly



Item	Description	3259-144 Part No.
1	3/4 Hp. Motor	5051
2	Power cord	28029
3	5/16-18x1.25 screw	38163
4	Flat Washer	2230
5	Vent Plug	3516
6	Large S Hook	2805
7	1/4-20x1.5 Socket Hd Screw	4412-1
8	Pinion Assembly	5052
9	Flat Washer	1484
10	Motor	5051
11	Drive Block	4642
12	Gear Head 696 RPM	3261-17
13	Pipe Plug (magnetic)	30160
14	Connector (90 Degree)	4228
15	Pipe Plug (oil level)	2755

# End Control Part No. 54336



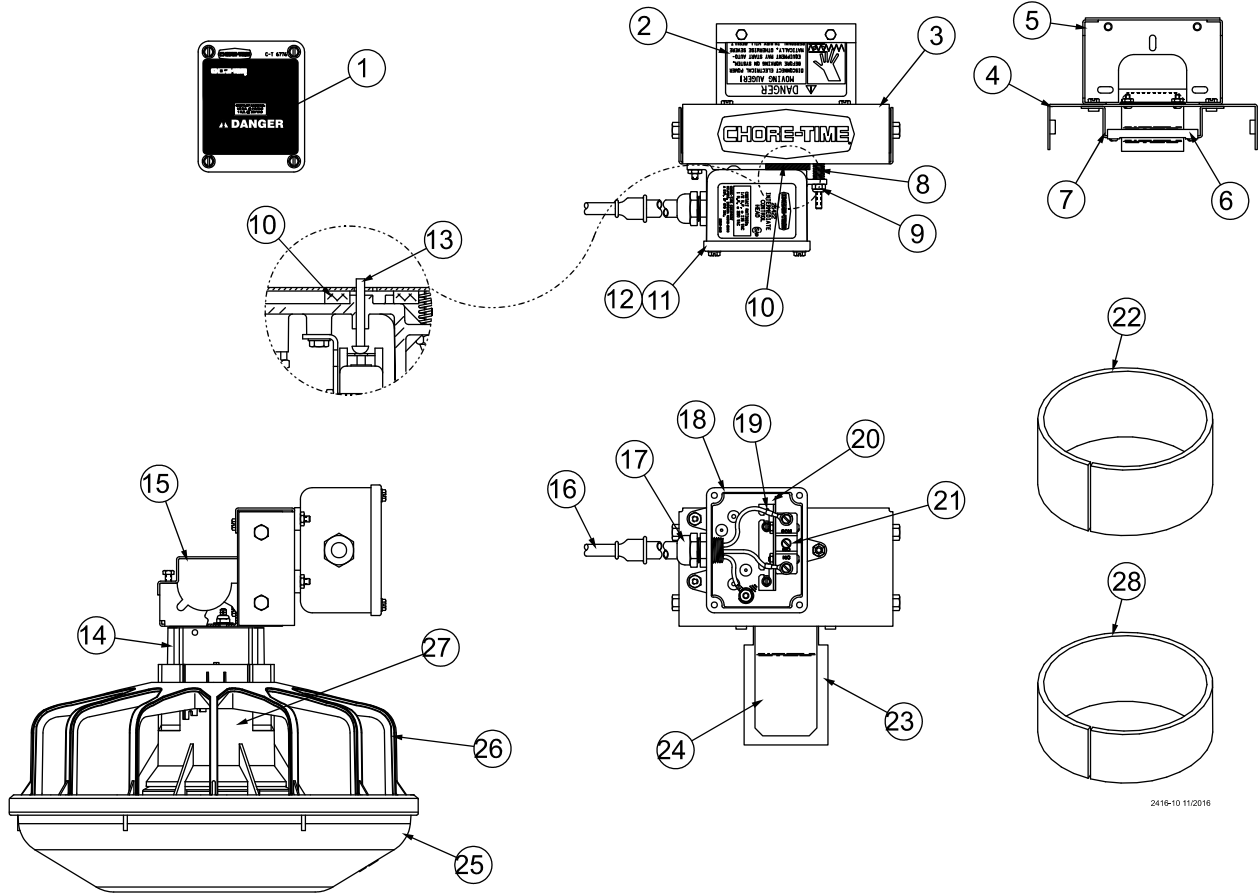
5418-7 1/2013



Item	Description	End Control Part No. 54336
1	Control Body	14434
2	Deflector Panel	41363
3	Paddle Retainer	25045
4	Control Cover Assembly	24682
5	Danger Decal	2527-9
6*	1/4-20x1-1/2 Socket Hd Screw	5083-8
7*	Driver Block	4642
8	Drive Tube Weldment	44794
9	Bottom Cover	14432
10	Control Cord Assembly	25495
11	1/2" Liquid Tight Connector	24685
12	Switch Box	24702
13	Switch Bracket	46122
14	Switch Insulation	1907-5
15	Actuator Switch	46091
16*	1/2" Liquid Tight Connector	23810
17	14" Flexible Conduit	26982-1
18*	Straight Liquid Tight Connector	26980
19	Cut Sleeve	55872
20	Anchor Plate	4188
21	Center Support Assembly	37371
22	Feeder Grill	39567
23	Mylar Assembly	25318
24	Feeder Pan	41500
25	Adjustment Cone	41504
26	Support Bracket	24683
27	Danger/Product Identification Decal	2529-1106
28	Gasket	6968-1
29	Actuator Pin	8757
30	Switch Box Gasket	6777
31	Switch Box Cover	6776
32	#10-32 Lock Nut	6963
33	Spring	6972
34	Switch Box Mount	25084
35	Paddle	46123
36	Stop Panel	25433
37	Switch Bracket	40749
38	Tube Closure Kit	14585
--	Anti-Roost Guard	2798
--*	Parts Package	40809

\*These items are included in the Parts Package.

# MODEL C2® PLUS Shallow Mid-line Control (42013)



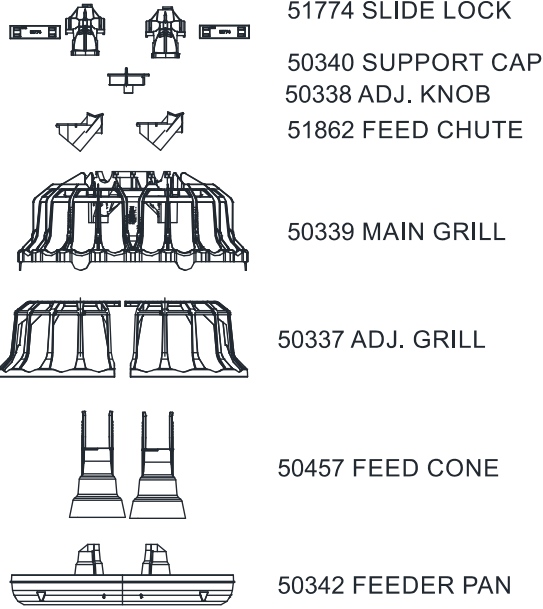
2416-10 11/2016

Item	Description	42013 MODEL C2 Plus Shallow Part No.
1	Danger/Product Identification Decal	2529-248
2	Danger Decal	2527-9
3	Back Cover	25047
4	Front Panel	25046
5	Tube Support	41364
6	Paddle Retainer	25045
7	Paddle support	25048
8	Tension spring	6972
9	#10 Lock nut	6963
10	Pivot Bracket	6968-1
11	Spring	6776
12	#10-32 Lock Nut	6777
13	Actuator Pin	8757
14	Support Cone Assembly	37371
15	Tube Retainer	14756
16	Cord Assembly	4999-49
17	1/2" Liquid Tight Connector	24685
18	Machined Switch Box	34842
19	Switch Bracket	46122
20	Switch Insulation	1907-5
21*	Actuator Switch	46091
22	Cut Sleeve	43110
23	Mylar Assembly	25318
24	Switch Paddle	46123
25	Feeder Pan	41500
26	Feeder Grill	39567
27	Adjustment Cone	41504
28	Cut Sleeve (for straight-line Genesis)	55872

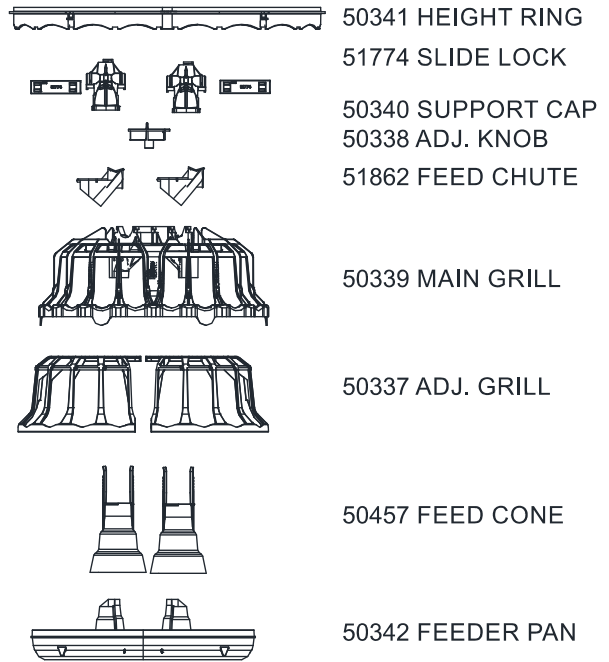
# GENESIS® Feeder Pan Assemblies

## GENESIS BREEDER PANS

GENESIS® BREEDER PAN  
WITHOUT HEIGHT RING  
PART NO. 51367

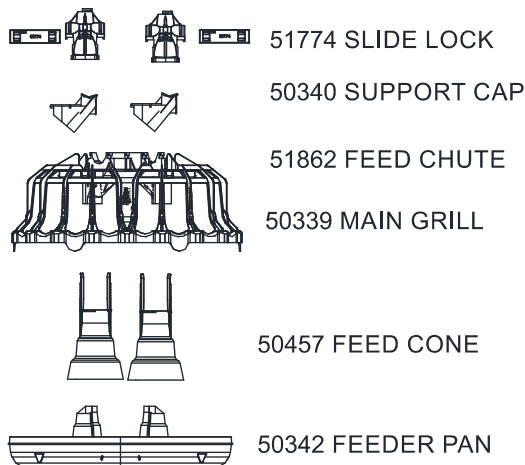


GENESIS® BREEDER PAN  
WITH HEIGHT RING  
PART NO. 51366

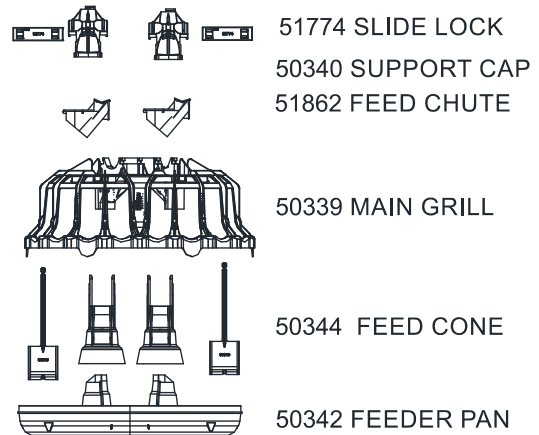


## GENESIS PULLET PANS

GENESIS® PULLET PAN  
NON-WINDOW  
PART NO. 51369

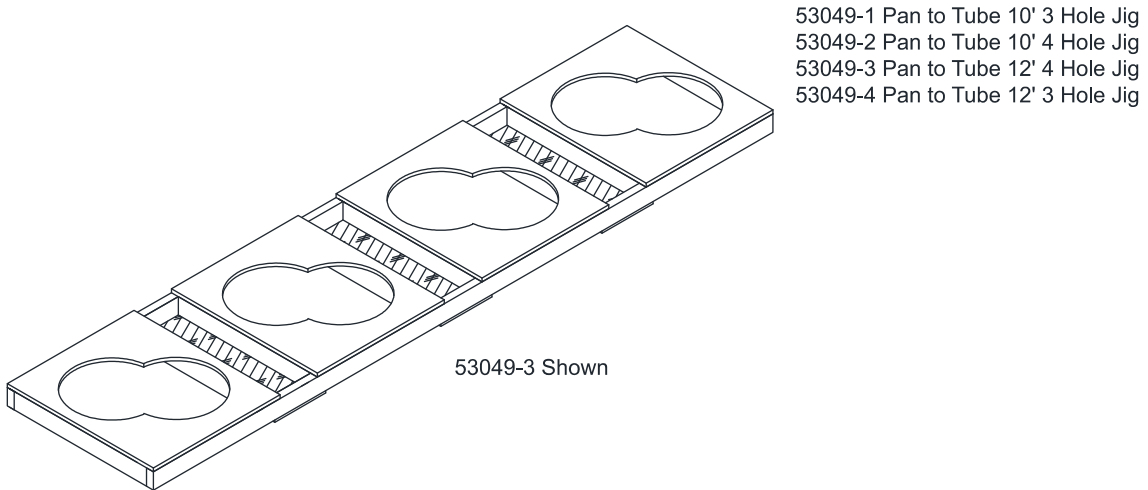
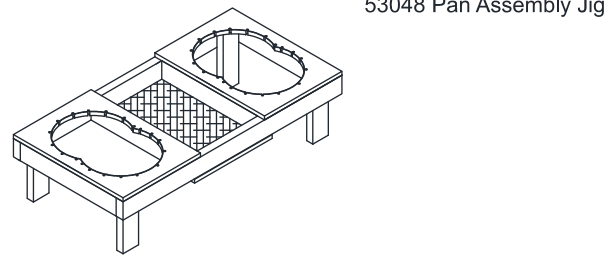
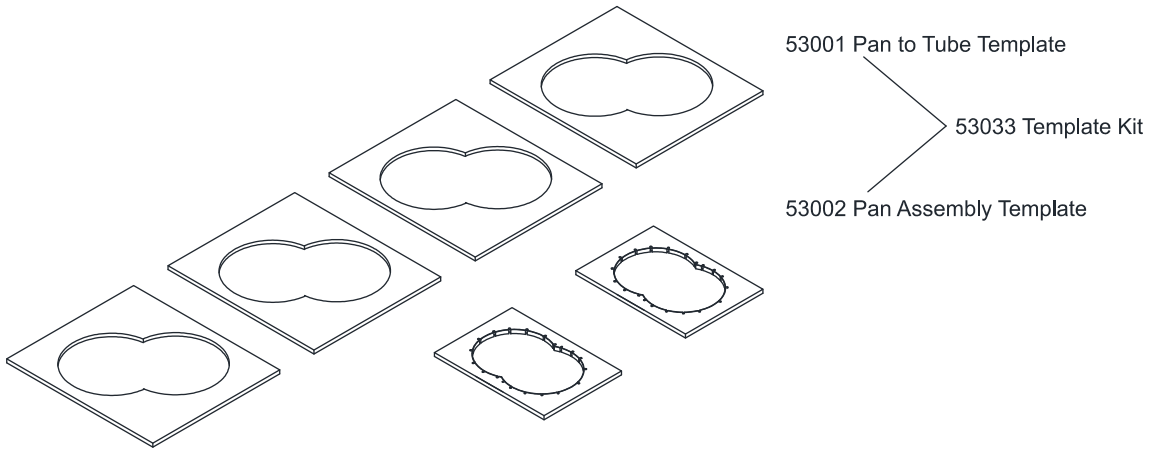


GENESIS® PULLET PAN  
WITH WINDOWS  
PART NO. 51368

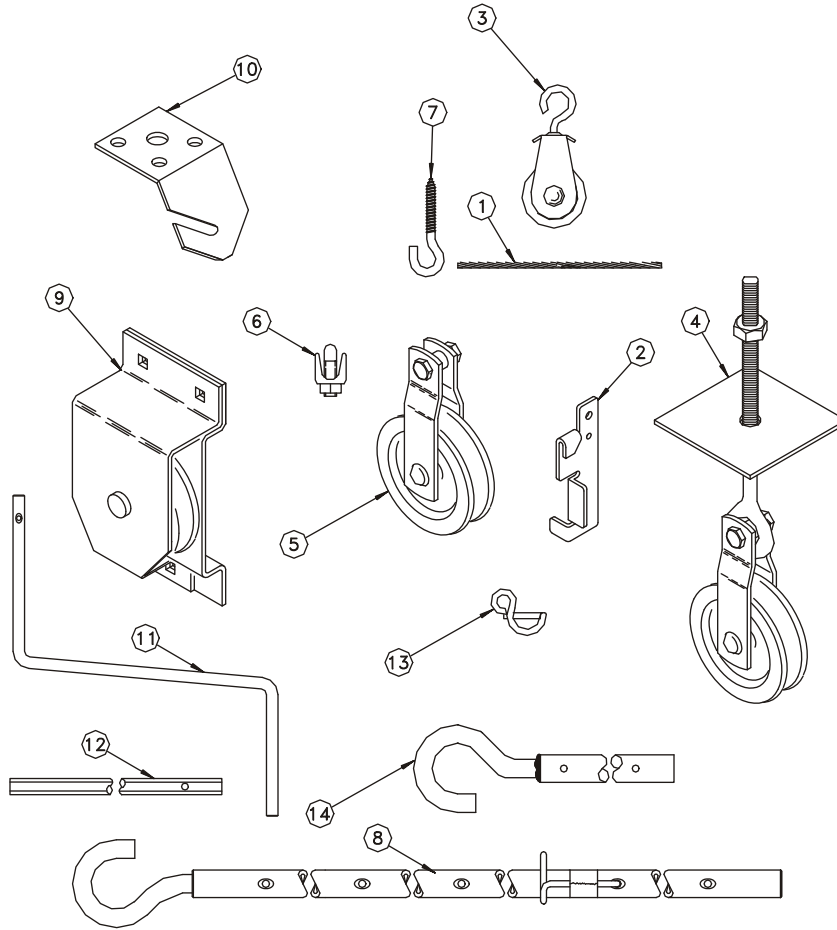


53520 GATE TOOL  
\*NOT INCLUDED

# Feeder Assembly Tools



# Feeder Line Suspension

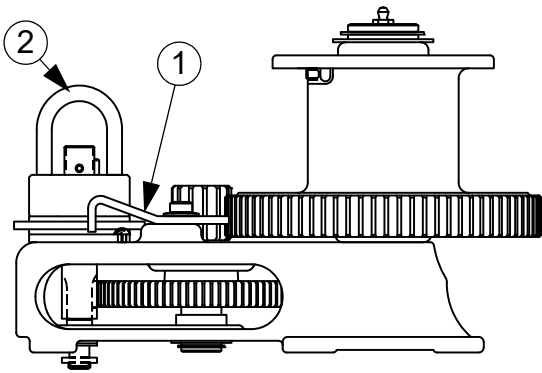


MF232-58 9/96

ITEM	PART NO.	DESCRIPTION
1	1213 27975	3/16" CABLE 7x7 1/8" CABLE
2	14337	ADJ. LEVELER
3	3004	SMALL PULLEY
4	2014	HEAVY DUTY PULLEY
5	2500	PULLEY
6	14898	3/16" CABLE CLAMP
7	1214	SCREW HOOK

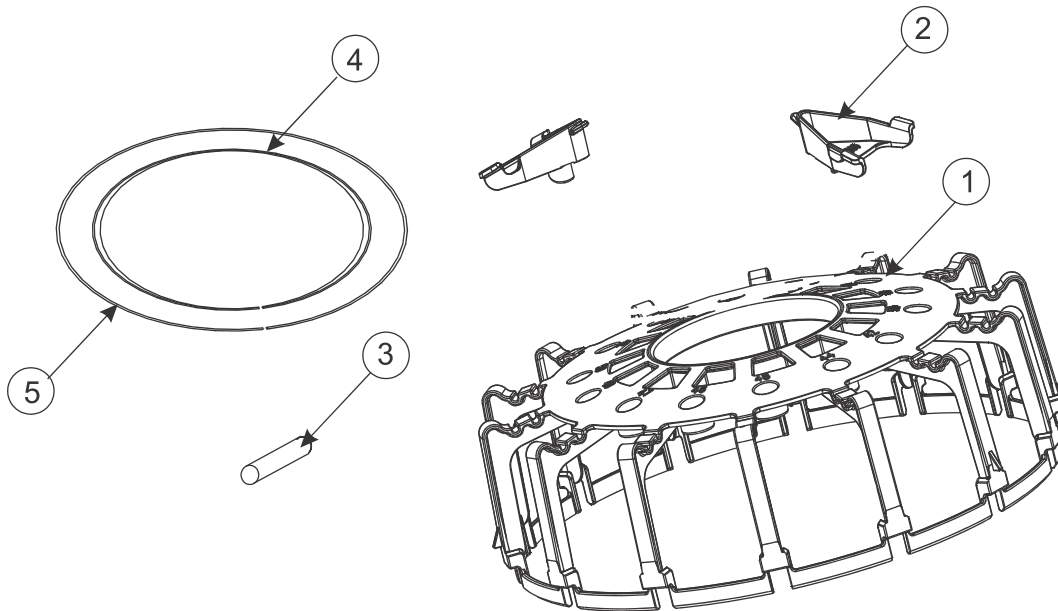
ITEM	PART NO.	DESCRIPTION
8	47637	EXTENDABLE DRIVE TUBE
9	28429	PULLEY ASSEMBLY
10	28550	CEILING HOOK
11	3148	HANDLE SHANK
12	2886	DRILL ADAPTER SHAFT
13	3761	WINCH HANDLE PIN
14	2884-1	DRIVE TUBE 4'

### Power Winch (Part No. 47687)



Item	Qty.	Description	Part No.
1	1	Pawl	47687-5
2	1	Input Shaft Assembly	47687-1

### MODEL C2® PLUS Adjustable Grill

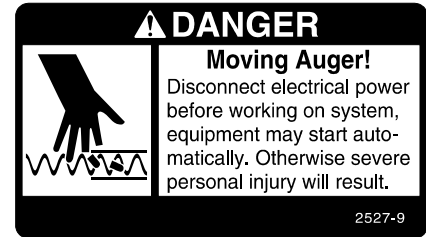
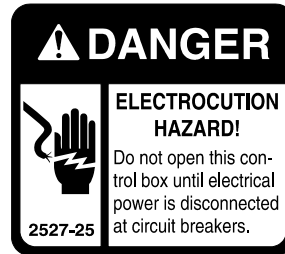


Item	Part No	Description
1	42499	Adjustable Grill
2	42500	Grill Lock
3	46440	Plastic Coupling
4	46439	2.75" Height Wire
5	46438	2.5" Height Wire
--	46435	Grill and Locks
--	46436	Grill, Lock and wire 2 3/4"
--	46437	Grill, Lock and wire 2 1/2"

# Trouble Shooting the Floor Feeding System

**ALWAYS DISCONNECT POWER TO THE SYSTEM WHEN SERVICING OR MAINTAINING THE EQUIPMENT. FAILURE TO DISCONNECT POWER MAY CAUSE INJURY OR DEATH.**

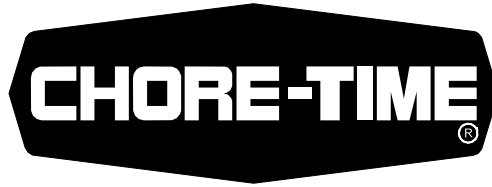
Service and maintenance work should be done by a qualified technician only.



Problem	Possible Cause	Corrective Action
None of the feeder lines will operate	No power supplied to equipment	Replace burned fuses or reset circuit breaker Make sure voltage required is supplied
	Time Clock or relay defective	Replace Time Clock or relay
	Time Clock improperly programmed	Refer to Programming the Time Clock section and reprogram the Time Clock
Feeder line will not operate	Power unit cord not plugged in sufficiently to make contact	Check motor cord plug at control unit and control unit plug at outlet for connection
	Motor cord wires are broken at plug or where cord enters motor	Check cord for continuity Replace if defective
	Power Units thermal overload tripped	Push motor overload reset button to reset
	Control unit switch defective or out of adjustment	Adjust switch according to the Switch Adjustment Procedure in the maintenance section
Motor overloads frequently	Oil on new auger loads motor excessively when feed is carried for first time	Polish auger by running 50 lb (20 kg) increments of feed out to pans
	Inadequate power reaching motors	Check line voltage at the motors Check starting current draw at motors Wiring of adequate size is essential to feeder operation
	Object caught in the auger; motor runs, stalls, then auger spins in reverse	Check hopper boot, control unit and pan outlet holes for foreign objects Remove obstruction
Auger runs erratically	Frozen or cracked bearing at boot anchor	Replace bearing Slowly ease auger back into tube Be careful not to damage the bearing when reinserting the auger
	Insufficient stretch in auger	Shorten the auger
	Obstruction in the auger	Remove obstruction
Auger tube or boot wears out rapidly (Noisy feeder operation)	Auger is bent or kinked	Repair or replace damaged auger
	End of auger is riding up on anchor weldment	Auger must not be positioned over weld on anchor Check for bent or damaged auger
Oil leaking out of seals on power unit	Gearhead vent plug not installed	Replace plastic shipping plug with vent plug
	Defective gear head seal	Replace seal
Not enough feed supplied to the feeder pans	Insufficient time programmed on the time clock	Add more operating time to feeding period
	Feeder line control unit switch out of adjustment	Adjust switch according to the Switch Adjustment Procedure in the maintenance section



**This page left blank intentionally.....**



**MADE TO WORK.  
BUILT TO LAST.®**

**Revisions to this Manual**

<b>Page No.</b>	<b>Description of Change</b>	<b>ECO</b>
63	Was 2883 Winch	35577
Various	Updated Graphics (Darker)	

**For additional parts and information, contact your nearest Chore-Time distributor or representative.  
Find your nearest distributor at: [www.choretime.com/contacts](http://www.choretime.com/contacts)**

CTB, Inc.  
PO Box 2000  
Milford, Indiana 46542-2000 USA  
Phone (574) 658-4101  
Email: [choretime@choretime.com](mailto:choretime@choretime.com)  
Internet: [www.choretime.com](http://www.choretime.com)