

Installation and Operators Manual

Installation and Operators Manual

# FLOOR FLOOD REVOLUTION<sup>®</sup> (FFR) 8 & 12 Feeder and Feeding System



# Contents

Topic	Page
<b>Limited Warranty</b> .....	<b>4</b>
<b>About This Manual</b> .....	<b>5</b>
<b>Safety Information</b> .....	<b>5</b>
<b>Safety Instructions</b> .....	<b>6</b>
Follow Safety Instructions.....	6
Decal Descriptions.....	6
<b>General</b> .....	<b>6</b>
Information.....	6
<b>Planning the Suspension System</b> .....	<b>7</b>
<b>General Installation Information</b> .....	<b>8</b>
<b>Laying out the Suspension System</b> .....	<b>8</b>
<b>Installing the Suspension System</b> .....	<b>9</b>
Power Lift Winch Installation.....	9
Installing the Main Winch Cable.....	10
Screw Hook Installation.....	11
Ceiling Hook Installation.....	12
Drop Installation.....	12
<b>Hopper Assembly and Suspension</b> .....	<b>13</b>
Assembly.....	13
Suspending the Hopper.....	13
<b>Feeder Pan Assembly</b> .....	<b>14</b>
Pan Assembly Procedure for FF Rev. 12 and 8 Feeders (Option 1).....	15
Cone Assembly.....	15
Feeder Pan Assembly (Using Box Fixture).....	16
Pan Assembly Procedure for (Not using Box).....	16
<b>Feeder Line Assembly and Suspension</b> .....	<b>17</b>
Feeder Pan and Tube Assembly Process.....	17
Assemble and Suspend the Feeder Line.....	17
<b>End Control and Boot Assembly Installation</b> .....	<b>18</b>
<b>Auger Installation</b> .....	<b>19</b>
Auger Brazing.....	22
<b>Mid-Line Control</b> .....	<b>23</b>
New Feeder Lines.....	23
Existing Feeder Lines.....	24
<b>Anti-Roost Installation</b> .....	<b>25</b>
Electro-guard Operation.....	27
<b>Feeder Management and Operation</b> .....	<b>28</b>
Initial Start-up of the Feeding System.....	28
General Operation of the Floor Flood Revolution® (FFR) 8 and 12 Feeders.....	29
Feeder Setting.....	30
REVOLUTION® Feeding System Operation Guide.....	31
One - two days prior to housing chicks.....	31
Day one - Day 4.....	31
Day five - Day 7.....	31

# Contents - continued

Topic	Page
Day 10 – 12	31
Day 16	31
Day 18 - 20	31
Day 20 – end of flock	31
End Control and Mid Line Control Pans	31
Controlling the Feeders (optional equipment)	31
<b>Maintenance</b>	<b>32</b>
Floor Feeding System Maintenance	32
Gear Head Maintenance	32
Feeder Line	33
Power Lift Winch Maintenance	34
<b>Trouble Shooting the Floor Feeding System</b>	<b>35</b>
<b>Wiring Diagrams</b>	<b>36</b>
End Control Internal Wiring	36
End Control With Electronic Sensor Wiring	37
Mid Line Control With Electronic Sensor Wiring	37
Electronic Sensor Three Phase(Ø) Wiring	38
<b>Parts Listing</b>	<b>39</b>
150# Hopper Kit and Switch (49268)	39
Hopper Mount Bracket (Optional)	40
Single Boot Components Part No. 6822	40
Twin Boot Components Part No. 6824	41
Feeder Line Components	42
Power Unit Assemblies	43
Power Unit Assembly Part Numbers:	43
Floor Flood Revolution® (FFR) End Controls	44
12 Spoke Mid-Line Control P/N 53965 and 8 Spoke Mid-Line Control P/N 53966	44
Floor Flood Revolution® (FFR) Mechanical Mid-Line Control	46
12 Spoke Mid-Line Control P/N 53967 and 8 Spoke Mid-Line Control P/N 53968	46
Floor Flood Revolution® (FFR) Mid-Line Control with Electronic Sensor	47
12 Spoke Control P/N 55491 and 8 Spoke Control P/N 55490	47
Floor Flood Revolution® (FFR) End Control with Electronic Sensor	48
12 Spoke Mid-Line Control P/N 55489 and 8 Spoke Mid-Line Control P/N 55488	48
Power Winch (Part No. 47687)	50
Miscellaneous Suspension Components	51
Feeder Components	52

# Limited Warranty

CTB, Inc. (“Chore-Time”) warrants the new CHORE-TIME products manufactured by Chore-Time to be free from defects in material or workmanship under normal usage and conditions, for One (1) year from the date of installation by the original purchaser (“Warranty”). Chore-Time provides for an extension of the aforementioned Warranty period (“Extended Warranty Period”) with respect to certain Product parts (“Component Part”) as set forth in the table below. If such a defect is determined by Chore-Time to exist within the applicable period, Chore-Time will, at its option, (a) repair the Product or Component Part free of charge, F.O.B. the factory of manufacture or (b) replace the Product or Component Part free of charge, F.O.B. the factory of manufacture. This Warranty is not transferable, and applies only to the original purchaser of the Product.

Component Part	Extended Warranty Period
RXL Fan (except motors and bearings)	Three (3) Years
TURBO® Fan (except motors and bearings)	Three (3) Years
TURBO® Fan fiberglass housing, polyethylene cone, and cast aluminum blade.	Lifetime of Product
TURBO® fan motor and bearings.	Two (2) Years
Chore-Time® Poultry Feeder Pan	Three (3) Years
Chore-Time® Rotating Centerless Augers (except where used in applications involving high moisture feed stuffs exceeding 17%)	Ten (10) Years
Chore-Time Steel Auger Tubes	Ten (10) Years
ULTRAFLO® Breeder Feeding System auger and feed trough.	Five (5) Years
ULTRAPAN® Feeding System augers .	Five (5) Years

### CONDITIONS AND LIMITATIONS

THIS WARRANTY CONSTITUTES CHORE-TIME’S ENTIRE AND SOLE WARRANTY AND CHORE-TIME EXPRESSLY DISCLAIMS ANY AND ALL OTHER WARRANTIES, INCLUDING, BUT NOT LIMITED TO, EXPRESS AND IMPLIED WARRANTIES, INCLUDING, WITHOUT LIMITATION, WARRANTIES AS TO MERCHANTABILITY OR FITNESS FOR PARTICULAR PURPOSES. CHORE-TIME shall not be liable for any direct, indirect, incidental, consequential or special damages which any purchaser may suffer or claim to suffer as a result of any defect in the Product. Consequential or Special Damages as used herein include, but are not limited to, lost or damaged products or goods, costs of transportation, lost sales, lost orders, lost income, increased overhead, labor and incidental costs, and operational inefficiencies. *Some jurisdictions prohibit limitations on implied warranties and/or the exclusion or limitation of such damages, so these limitations and exclusions may not apply to you. This warranty gives the original purchaser specific legal rights. You may also have other rights based upon your specific jurisdiction.*

Compliance with federal, state and local rules which apply to the location, installation and use of the Product are the responsibility of the original purchaser, and CHORE-TIME shall not be liable for any damages which may result from non-compliance with such rules.

The following circumstances shall render this Warranty void:

- Modifications made to the Product not specifically delineated in the Product manual.
- Product not installed and/or operated in accordance with the instructions published by the CHORE-TIME.
- All components of the Product are not original equipment supplied by CHORE-TIME.
- Product was not purchased from and/or installed by a CHORE-TIME authorized distributor or certified representative.
- Product experienced malfunction or failure resulting from misuse, abuse, mismanagement, negligence, alteration, accident, or lack of proper maintenance, or from lightning strikes, electrical power surges or interruption of electricity.
- Product experienced corrosion, material deterioration and/or equipment malfunction caused by or consistent with the application of chemicals, minerals, sediments or other foreign elements.
- Product was used for any purpose other than for the care of poultry and livestock.

The Warranty and Extended Warranty may only be modified in writing by an officer of CHORE-TIME. CHORE-TIME shall have no obligation or responsibility for any representations or warranties made by or on behalf of any distributor, dealer, agent or certified representative.

Effective: **April, 2014**

## About This Manual

The intent of this manual is to help you in two ways. One is to follow step-by-step in the order of assembly of your product. The other way is for easy reference if you have questions in a particular area.

**Important:** Read **ALL** instructions carefully before starting construction.

**Important:** Pay particular attention to all **SAFETY** information.

- *Metric measurements are shown in millimeters and in brackets, unless otherwise specified. “ ” equals inches and “ ’ ” equals feet in English measurements.*

*Examples:*

*1" [25.4]*

*4' [1 219]*

- Optional equipment contains necessary instructions for assembly or operation.
- Very small numbers near an illustration (*i.e.*, 1257-48) are identification of the graphic, not a part number.

Note: The original, authoritative version of this manual is the English version produced by CTB, Inc. or any of its subsidiaries or divisions, (hereafter collectively referred to as “CTB”). Subsequent changes to any manual made by any third party have not been reviewed nor authenticated by CTB. Such changes may include, but are not limited to, translation into languages other than English, and additions to or deletions from the original content. CTB disclaims responsibility for any and all damages, injuries, warranty claims and/or any other claims associated with such changes, inasmuch as such changes result in content that is different from the authoritative CTB-published English version of the manual. For current product installation and operation information, please contact the customer service and/or technical service departments of the appropriate CTB subsidiary or division. Should you observe any questionable content in any manual, please notify CTB immediately in writing to: CTB Legal Department, P.O. Box 2000, Milford, IN 46542-2000 USA.

## Safety Information

**Caution, Warning and Danger Decals** have been placed on the equipment to warn of potentially dangerous situations. Care should be taken to keep this information intact and easy to read at all times. Replace missing or damaged safety decals immediately.

Using the equipment for purposes other than specified in this manual may cause personal injury and/or damage to the equipment.

### Safety–Alert Symbol



**This is a safety–alert symbol.** When you see this symbol on your equipment, be alert to the potential for personal injury. This equipment is designed to be installed and operated as safely as possible...however, hazards do exist.

### Understanding Signal Words

**Signal words** are used in conjunction with the safety–alert symbol to identify the severity of the warning.



**DANGER** indicates an imminently hazardous situation which, if not avoided, **WILL** result in death or serious injury.



**WARNING** indicates a potentially hazardous situation which, if not avoided, **COULD** result in death or serious injury.



**CAUTION** indicates a hazardous situation which, if not avoided, **MAY** result in minor or moderate injury.

## Safety Instructions

### Follow Safety Instructions

Carefully read all safety messages in this manual and on your equipment safety signs. Follow recommended precautions and safe operating practices.

Keep safety signs in good condition. Replace missing or damaged safety signs.

### Decal Descriptions

#### DANGER: Moving Auger

This decal is placed on the Panel Weldment.

Severe personal injury will result, if the electrical power is not disconnected, prior to servicing the equipment.

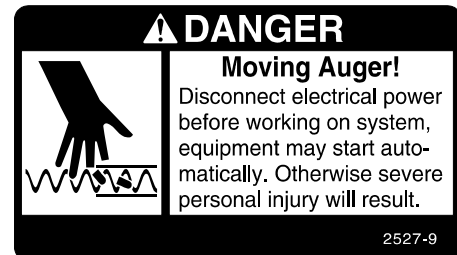

#### DANGER: Electrical Hazard

Disconnect electrical power before inspecting or servicing equipment unless maintenance instructions specifically state otherwise.

Ground all electrical equipment for safety.

All electrical wiring must be done by a qualified electrician in accordance with local and national electric codes.

Ground all non-current carrying metal parts to guard against electrical shock.

With the exception of motor overload protection, electrical disconnects and over current protection are not supplied with the equipment.

#### CAUTION:

Use caution when working with the Auger—springing Auger may cause personal injury.

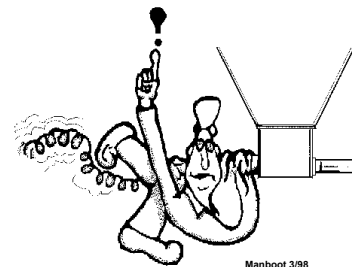
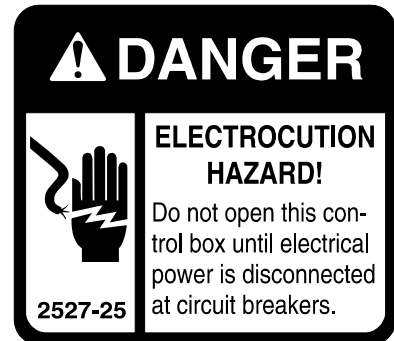

## General

### Information

The Chore-Time Floor Flood REVOLUTION® (FFR) 8 and 12 Feeders and Feeding System has been designed to feed poultry. Using this equipment for any other purpose or in a way not within the operating recommendations specified in this manual will void the warranty and may cause personal injury.

This manual is designed to provide comprehensive planning and installation information. The Table of Contents provides a convenient overview of the information in this manual.

# Planning the Suspension System

1. Select the House Layout.

A. Optional Mid Line Controls may be used for partial house brooding. See Figure 1..

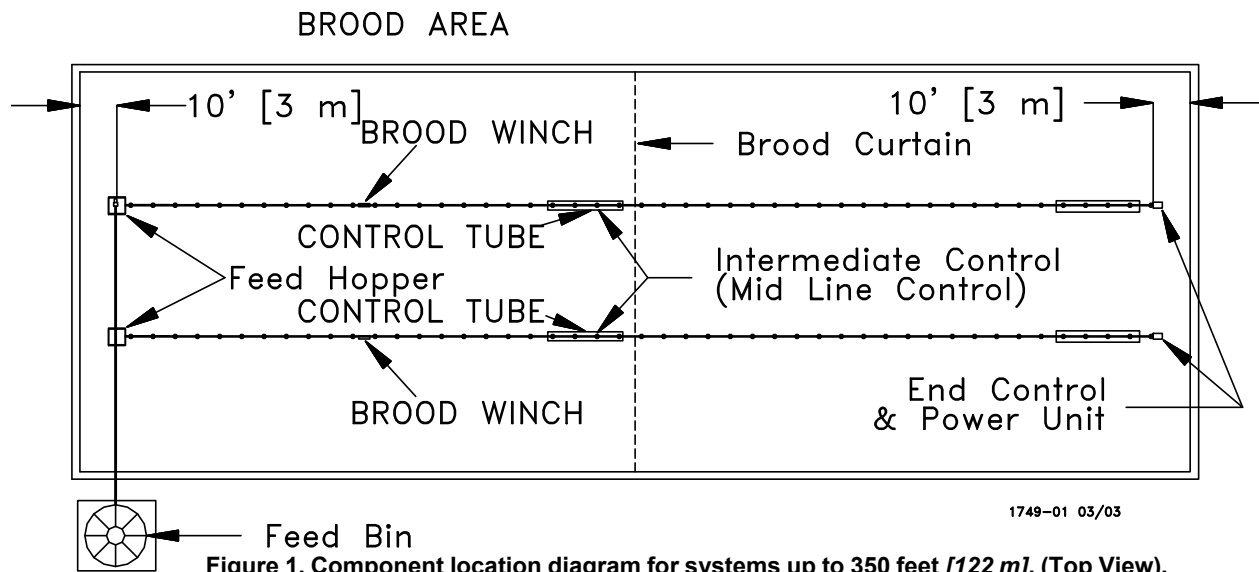

Figure 1. Component location diagram for systems up to 350 feet [122 m]. (Top View).

B. Systems with line lengths over 350' [122 m] should be split in the center, as shown in Figure 2.. This will reduce auger running time and eliminate the need for Mid-Line Controls for partial house brooding.

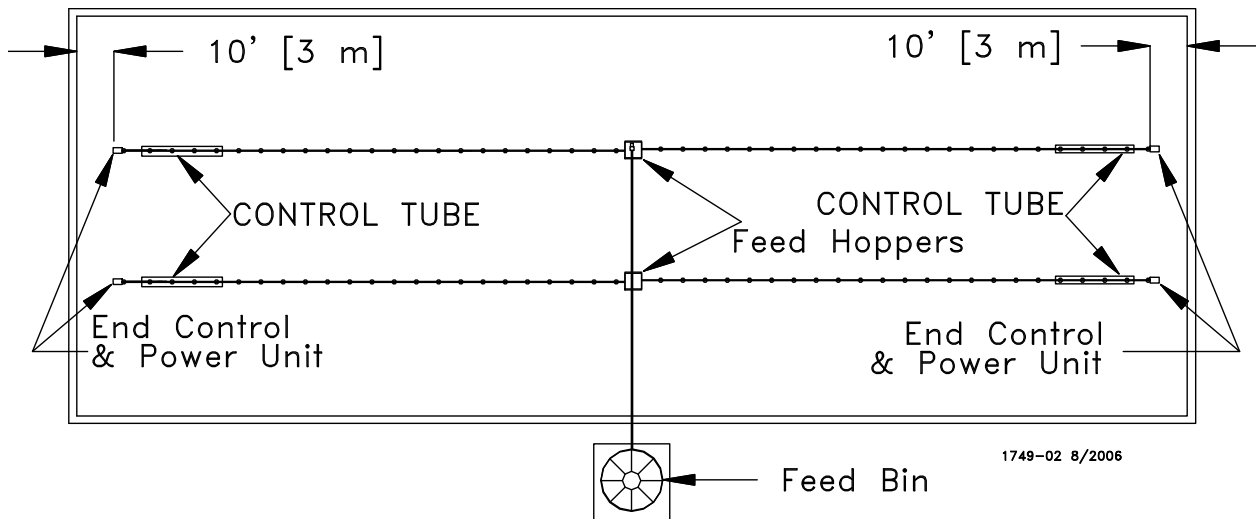

Figure 2. Component location diagram for systems over 350 feet [122 m]. (Top View).

2. Determine the Feed Bin location.
3. Determine the Brood Curtain location.
4. **Determine the number of actuators (96 pans per actuator Maximum).**
5. Determine the location for the End Control Pans, and if used the Mid Line Control Pans. **The Feeder Control Pans should be at least 10' [3 m] from the Wall or Brood Curtain.**
6. Determine the distance to the Feeder Line from the Side Wall.
7. Determine the distance from the Feed Hoppers to the End Wall for a Straight Line Feeding System.

# General Installation Information

Please read the installation instructions in this manual prior to beginning the installation. This manual provides the necessary information on the installation, operation, and maintenance of the Chore-Time feeding equipment you have purchased.

The suspension, hopper assembly, feeder line installation, and anti-roost installation is the same for each system, except where noted otherwise. Please pay particularly close attention to insure proper assembly and installation of the equipment.

The REVOLUTION® 8 and 12 FEEDER Control Units use a 348 RPM. Gearhead, delivering approximately 17 lbs [7.7 kg] per minute. This rating is based on feed with a density of 40 lbs per cubic foot [640 kg per cubic meter].

Single phase 60 Hz and single and three phase 50 Hz Power Units are available for the Rev. 12 and 8 Feeders.

Systems up to 300' [91 m] require 1/3 HP. Power Units. Systems over 300' [91 m] require 1/2 HP. Power Units.

# Laying out the Suspension System

1. Select the Suspension type.
  - A. For systems up to 350' [107 m]

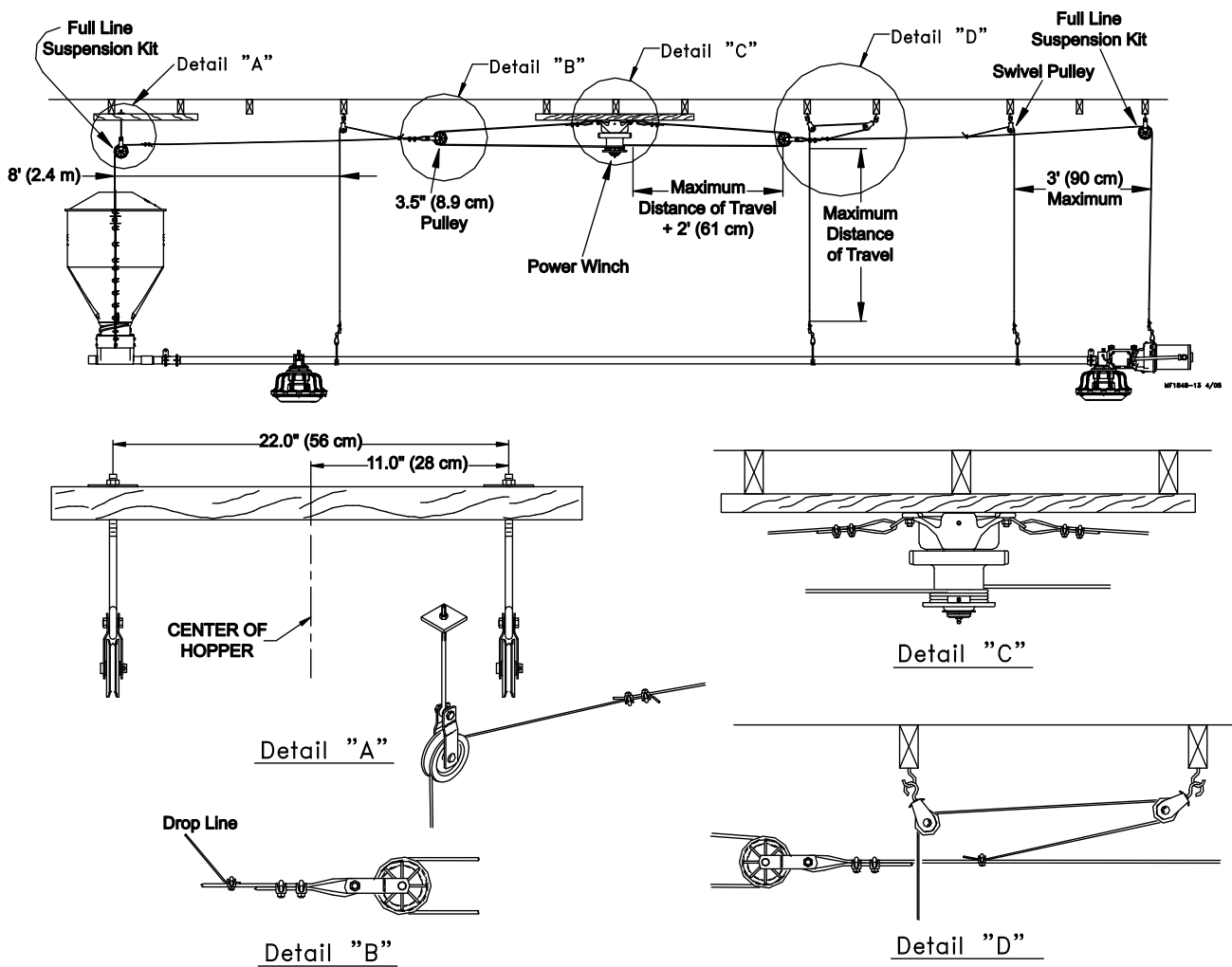

Figure 3. Suspension for systems up to 350' [107 m]



B. For systems over 350' [107 m]

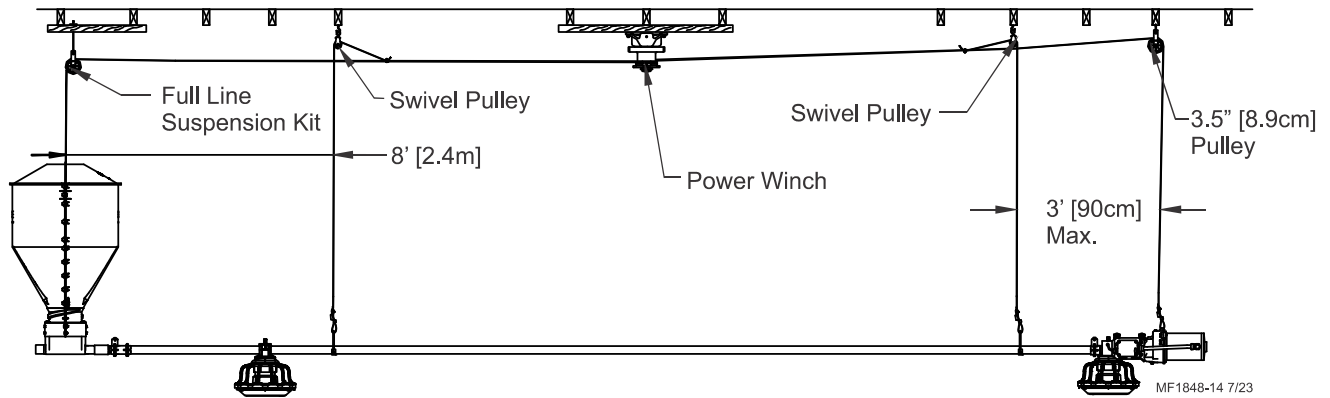

Figure 4. Suspension for systems over 350' [107 m]

2. Locate the Power Lift Winch. The Power Lift Winch requires a support that will span, in a wood frame house at least 3 rafters, and in a steel frame house at least 2 rafters.
3. Locate the Power Unit and Feed Hopper. Special support is required at each Power Unit and Feed Hopper location.
4. Determine the Drop Location and length. Suspension systems are based on ceiling heights of 14' [4.3 m] with suspension drop points every 8' [2.4 m]. DO NOT EXCEED 10' [3 m] BETWEEN SUSPENSION DROPS.
5. Determine the location for Screw Hooks. Mark a straight line or use cable to locate Screw Hooks. Use the offset of Screw Hooks where necessary.

## Installing the Suspension System

### Power Lift Winch Installation

1. Bolt the Power Winch, fully assembled, to the Power Lift Winch Support, either a 2" x 8" [50x200 mm] board that will span at least 3 rafters or a 3/8" [9.5 mm] thick steel plate welded to two pieces angle iron that are each long enough to span at least 2 rafters, using 5/16-18 hardware supplied in the Hardware Package. The brake mechanism will extend toward one side.

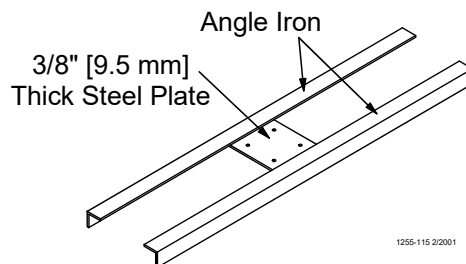

Figure 5. Optional Power Lift Winch support detail

Install a Cable Hook, supplied in Hardware Package, between the mounting bolt and Power Winch frame, as shown in **Figure 6**.

- Assembling the Power Winch to the Rafters
2. Attach the Power Lift Winch Support (with the Power Winch secured) to the ceiling at the center of the feeder line. See **Figure 7**. The Power Lift Winch Support must be parallel to the feeder line and must span at least 3 rafters in a wood frame house and 2 rafters in a steel frame house.

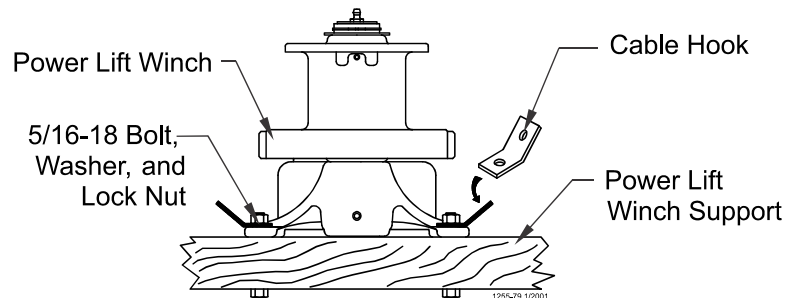

Figure 6. Assembling the Power Winch to the Rafters

If the hopper is located at the center of the feeder line, locate the Power Winch a few feet offset from the center of the feeder line. However, the Winch Drum must be directly in line with where the main cable is to be installed.

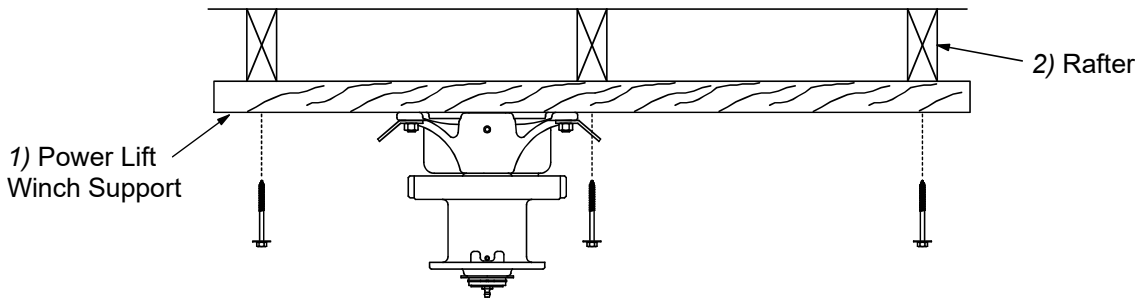

Figure 7. Mounting the Power Lift Winch and Support to the Rafters

### Installing the Main Winch Cable

The Suspension Systems are based on ceiling heights of 14' [4.3 m] with Suspension Drop points every 8' [2.4 m]. DO NOT EXCEED 10' [3 m] BETWEEN SUSPENSION DROPS. Refer to suspension section in this manual for installation details.

Adequate overhead structure must be provided to support the weight of the feeders, hoppers, power units, etc. The Suspension System is the same for the Rev. 12 and 8 Feeders. The type of installation required depends on the feeder line length.

#### IMPORTANT: Special support is required at each Hopper location.

•Power Unit Locations: **The Feeder Line must be supported within 3' [.9 m] of the Power Unit.** This is in addition to the required Power Unit suspension. If the Control Unit or Hopper does not come out directly under a truss, fasten a pulley to a 2" x 8" [50 x 200 mm] board or steel angle that will span 2 trusses and is capable of supporting 300 lbs [136 kg] for the Hopper and 75 lbs [34 kg] for the Control Unit.

•Feed Hopper Locations: **When steel hoppers with center suspension are used, see figure 8, the feeder line must be supported within 1' [30 cm] of the feed hopper.** When plastic hoppers are installed only 2 point suspension can be used, see figure 9, this does not require additional supports. See page 13 for plastic hopper suspension. This is in addition to the required Feeder Hopper suspension. After determining the type of suspension system required, decide where the Feeder Line is to be installed. Mark a straight line on the ceiling or rafters the full length of the Feeder Line. Use a string, chalk line, or the winch cable, temporarily attached with staples, to mark the line. Center the line directly over where the Feeder Line is to be installed.

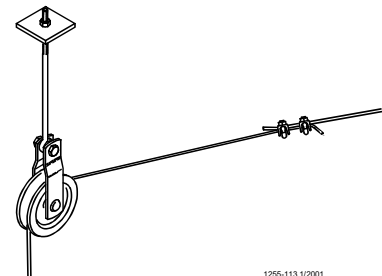

Figure 8. Steel Hopper Suspension

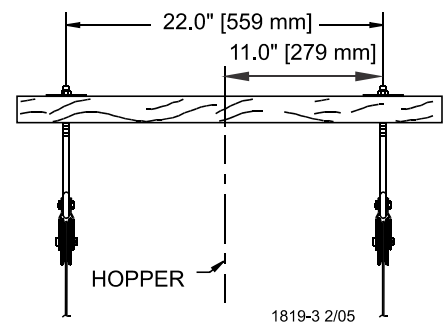

Figure 9. Plastic Hopper Suspension

3. Extend the 3/16" [5 mm] Main Winch Cable the full length of the feeder line. Attach the cable temporarily to the ceiling with nails, staples, or some type of fasteners. **Figure 10** shows a double back arrangement for feed lines over 350' [107 m].

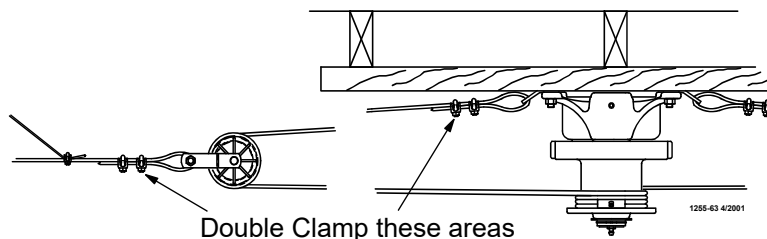

Figure 10. Double back arrangement for feed lines over 350' [107 m]

- Route the cable through the Winch Drum Relief located near the bottom of the drum. Tighten the set screw to anchor the cable to the drum. See Figure 11.

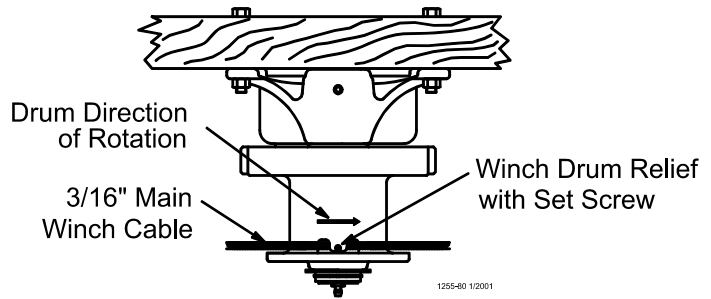

Figure 11. Attaching the Cable to the Power Winch

- Turn the winch drum one full revolution. Guide the cable against the flange at the bottom of the winch drum. The cable must not wrap over itself on the drum, but should be wrapped as close as possible to each previous wrap. See Figure 12.

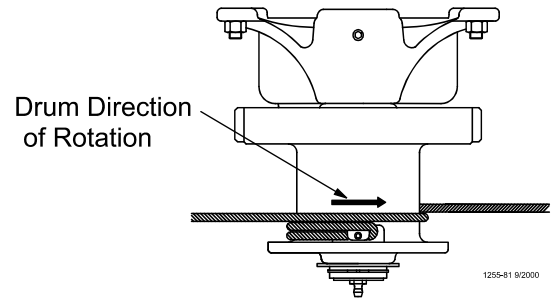

Figure 12. Power Winch Drum Rotation

### Screw Hook Installation

The recommended distance between the drops for the Rev. 12 & 8 FEEDER is 8' [2.4 m] on center. Do not exceed 10' [3 m] spacing on drop lines.

If the distance raised is greater than the distance between the drop spacings, offset the hooks 3" [7.6 cm] to each side of the line to prevent the cable clamps from catching the pulleys, see figure 13.

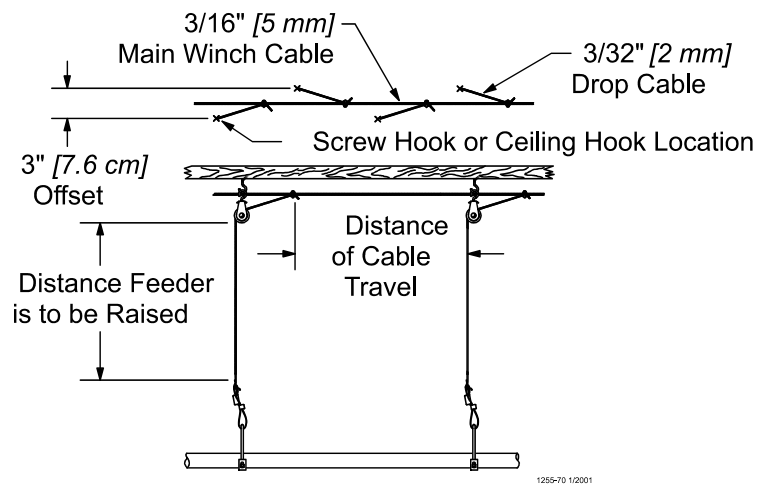

Figure 13. Drop Line Off Set Detail

Screw the hook into the truss the full length of the threads to prevent bending.

The openings of the screw hooks must be pointed away from the direction of travel when the Power Winch raises the feeder line. See Figure 14.

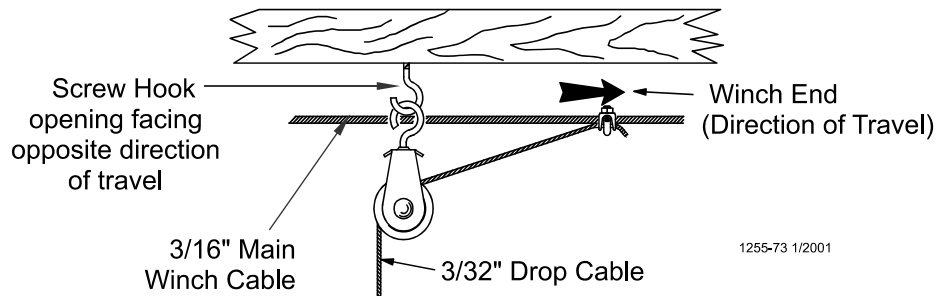
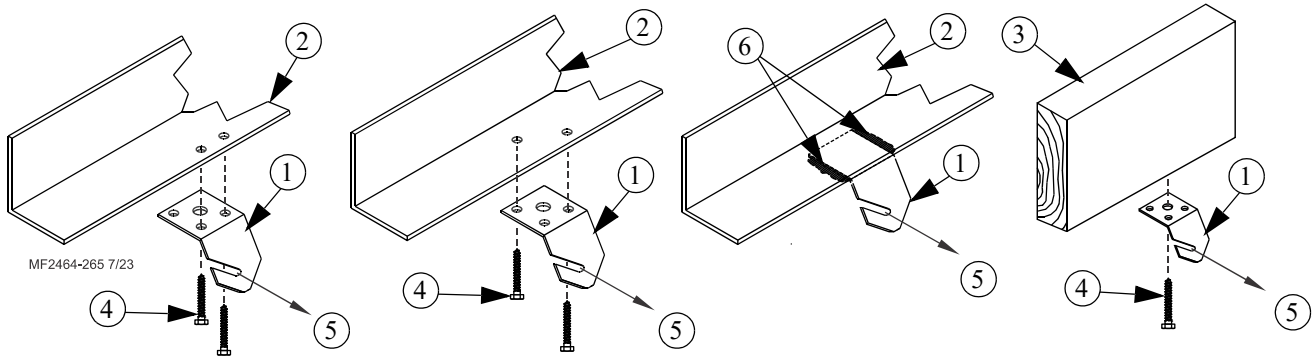

Figure 14. Screw Hook Installation

### Ceiling Hook Installation



Item	Description	Part No.
1	Ceiling Hook	28550
2	Steel Truss	--
3	Wood Truss	
4	1/4-20 Lag Screw	--
5	Cable Travel Direction	--
6	Weld	--

Figure 15. Ceiling Hook Installation

6. After securing the Ceiling Hook to the truss, slide the hook of a Swivel Pulley into the slot, as shown in Figure 16.

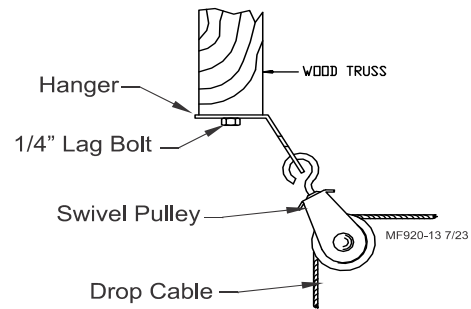

Figure 16. Pulley Installation

### Drop Installation

1. Refer to page 11 Figure 14. for installing Screw Hooks.
2. Attach a 3004 Pulley to each hook.
3. Thread the end of the 3/32" or 1/8" cable through the pulley toward the winch. Clamp this end to the 3/16" winch cable about 6" [150 mm] from the last pulley, using a 3/16" cable clamp. See applicable figure; Figure 14 or 17.
4. Allow enough cable length for installation of the Adjustment Leveler. Sufficient cable is included to provide "throwbacks" on drops located beneath and near the winch. Figure 17 shows a "throwback" cable arrangement.

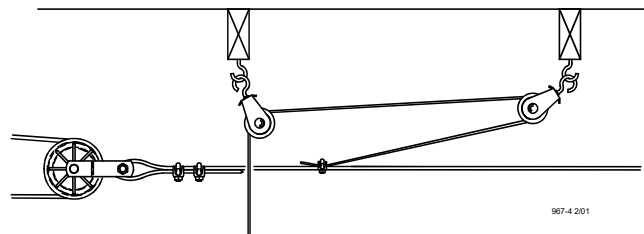

Figure 17. "Throwback" cable arrangement

5. Begin installing suspension drops at the winch and proceed to the ends of the feeder line.

Keep the main cable tight between drops. It may be necessary to hang a weight on the end of the cable to maintain tension on the line.

# Hopper Assembly and Suspension

The 150 lb. Hopper Assembly is **NOT designed for single-point suspension**. The upper cross brace is designed for supporting the drop tube **ONLY**. This Hopper Assembly is to have **Two-point** suspension as stated.

## Assembly

1. Assemble the 1/4-20 x 1-1/2" bolt to the brace with two 1/4-20 nuts. One nut should be assembled under the brace with the other on top. This bolt is to provide a place for the tube support assembly chain to be hooked, see **figure 18**.
2. Assemble the 150 lb. hopper halves and brace as shown in **Figure 18**, using #14 x 5/8" screws (supplied in hardware package).
3. Assemble the #8 x 1/2" screws and chain as shown in **Figure 18**.
4. Assemble suspension angles and suspension braces around feeder line boot (single or twin), using 1/4-20 x 1/2" Hex bolts and nuts (supplied in hardware package), see **figure 19**.

**Note: The larger holes on the ends of the suspension angles need to be on the upper side of the assembly.**

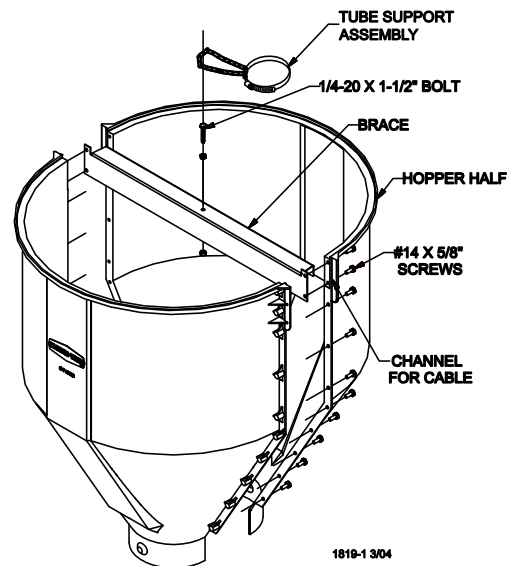

Figure 18.

5. Assemble the twist lock collar to the top of the feeder line boot (single or twin) using 1/4-20 x 1/2" bolts and lock nuts (supplied in hardware package), see **figure 19**.
6. Assemble the adjustment brackets to the suspension angles with 5/16-18 x 3/4" bolts and nuts (supplied in hardware package).
7. Two cable assemblies (cable with a sleeve clamp and a 5/32 thimble) are supplied with the suspension kit to support the hopper. Attach the cable assemblies to the adjustment brackets using the top holes of the adjustment brackets, see **figure 19**.

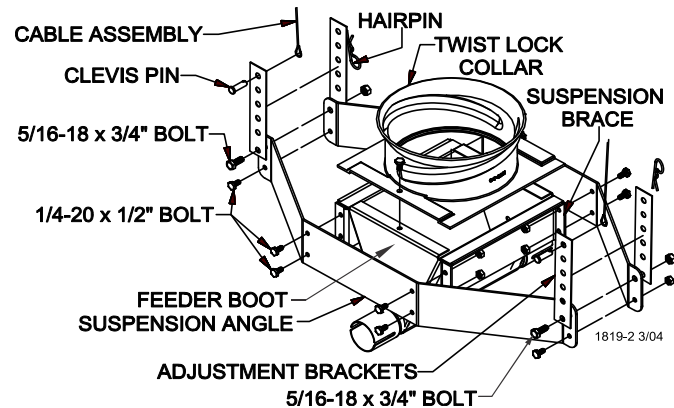

Figure 19.

8. Install two pulleys to either a 2" x 8" [50x200 mm] board that will span at least 3 rafters or a 3/8" [9.5 mm] thick steel plate welded to two pieces of angle iron that are long enough to span at least 2 rafters. Install the pulleys directly above the feeder line where the hopper is to be located. The pulleys should be spaced 22" [559mm] apart (11" [279 mm] from the center of the hopper in both directions), see **figure 20**.

## Suspending the Hopper

1. Attach the boot to the feeder line.
2. Route the two cable assemblies up and around the pulleys.
3. Level the boot with the feed line and clamp the cables to the main cable using 1 cable clamp per cable assembly.
4. Place the hopper on top of the twist lock collar and rotate the hopper 90 degrees into position.

**Make sure the cables lay in the channels on the sides of the hopper for support then use the hairpin to contain the cable.**

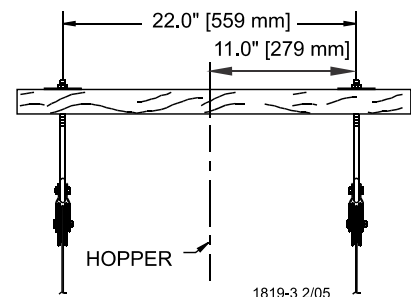

Figure 20.

## Feeder Pan Assembly

All feeders assemble in the same manor. Refer to **Figure and 25**. The inner cone must turn freely. Align the threads on the outside of the adjustment cone and the grill cap. Turn the cone assembly into the grill cap. Continue turning grill until the pointer lines up with the #4 position. See **Figure** . Turn the grill and cone assembly over place the feeder pan on the grill, turn the pan clockwise until the lock engages. Assemble the remaining Feeders. Assembly Box Construction for Rev. 12 and 8 Feeders.

Figure 21A

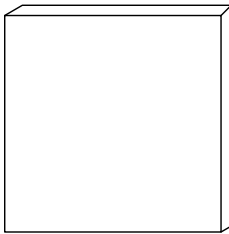

Figure 21B

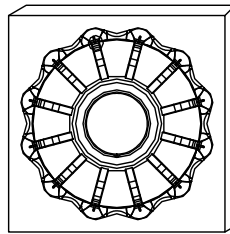

Figure 21C

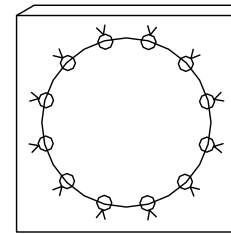

Figure 21D

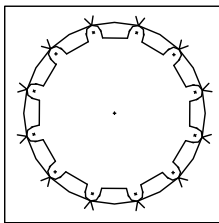
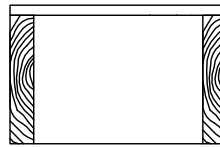
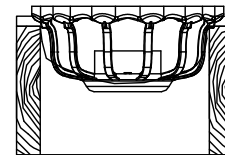

Figure 21E



MF1749-42 7/23

Figure 21F



**Figure 21.Assembly Box Construction**

This information and assembly only applies to FF Rev. 12 and 8 feeder installations.

Chore-Time recommends building an assembly box to aid in assembling the FF Rev. 12 and 8 feeders for pan assembly procedure option 1(see next page).

To build the assembly box for the Rev. 12 feeder, use a 16" [406 mm] x 17" [432 mm] piece of plywood and two 14-1/2" and two 17" [432 mm] long pieces of 2" [51 mm] x 12" [305 mm].

1. Cut a piece of 3/4" [19 mm] plywood 16" [406 mm] X 17" [432 mm]. See **Figure 21A**.
2. Center the grill on the 16" [406 mm] X 17" [406mm] piece of plywood. Use a pencil and draw around the inside edge of the grill as shown in **Figure 21B**.  
Mark a "V" at each strut location.
3. Remove the grill.  
Use a 7/8" [22 mm] spade bit to drill a hole at each strut location, as shown in **Figure 21C**.
4. Use a sabre saw to cut along the *inside* circle, between the 7/8" [22 mm] holes. See **Figure 21D**.
5. Use (2) 14-1/2" [368 mm] and (2) 17" [432 mm] 2 [51 mm] x 12" [305 mm] to construct the box sides. Nail the 3/4" [19 mm] plywood fixture to the box. See **Figure 21E**.  
It is important to use at least 12" [305 mm] sides for the box. Smaller lumber will not allow sufficient depth for the grill to be placed in the box face down.

**Figure 21F** shows how the grill should fit down in assembly box. NOTE: Board is cut away for clarity only.

## Pan Assembly Procedure for FF Rev. 12 and 8 Feeders (Option 1)

### Cone Assembly

1. Line up the Tab in the Inner Cone with the Track on the Outer Cone and slide the Inner into the Outer.

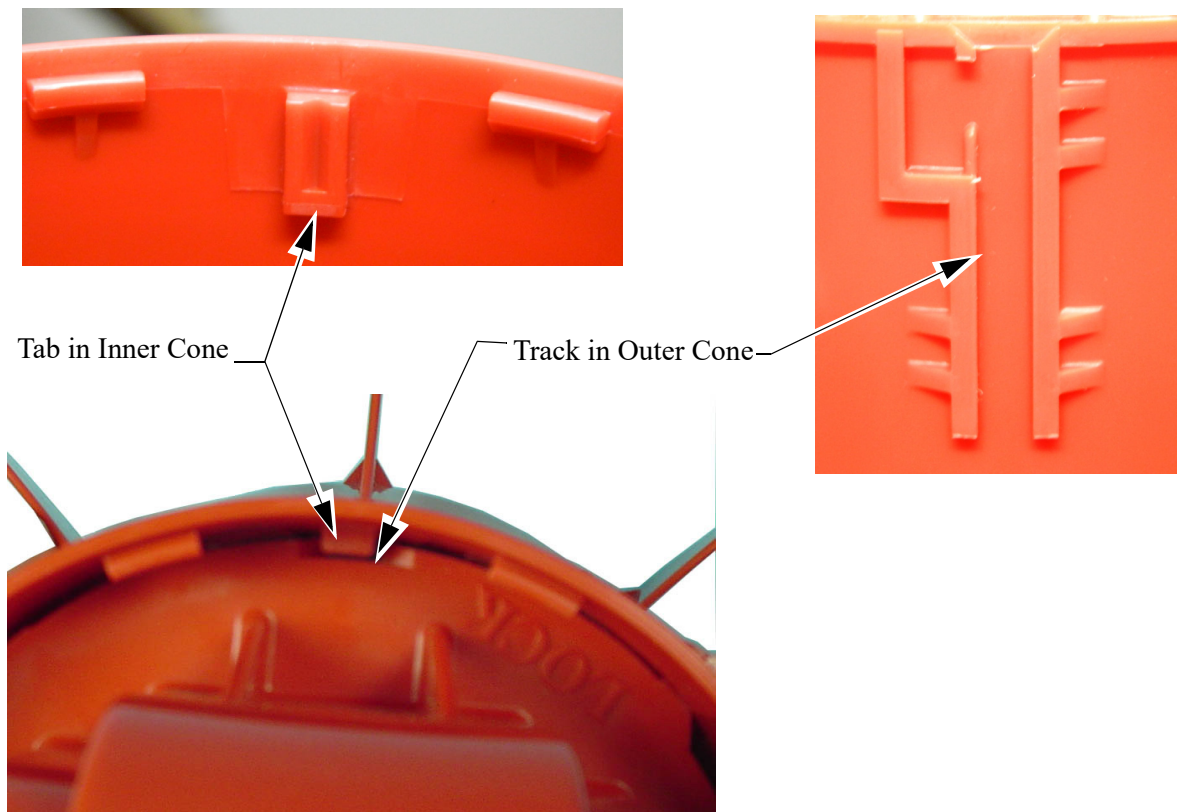

**Figure 22. Tab and Track alignment**

2. When the Inner Cone reaches the top of the Outer Cone, Squeeze the Sides of the Outer Cone to allow for the Cones to lock into place.



**Figure 23. Squeeze Outer Cone**

### Feeder Pan Assembly (Using Box Fixture)

1. After the Cones are assembled, place a Grill in the Pan assembly box fixture.
2. Install Cone Assembly in the Grill, **Check fit, correct, grill and Cone should be snug, incorrect if Grill and Cone have free motion.**
3. Place the Feed Pan in the Grill Ring, The Pan must be fully seated in the Grill then rotate the Pan until it locks into the Grill. Rotate to position #4.

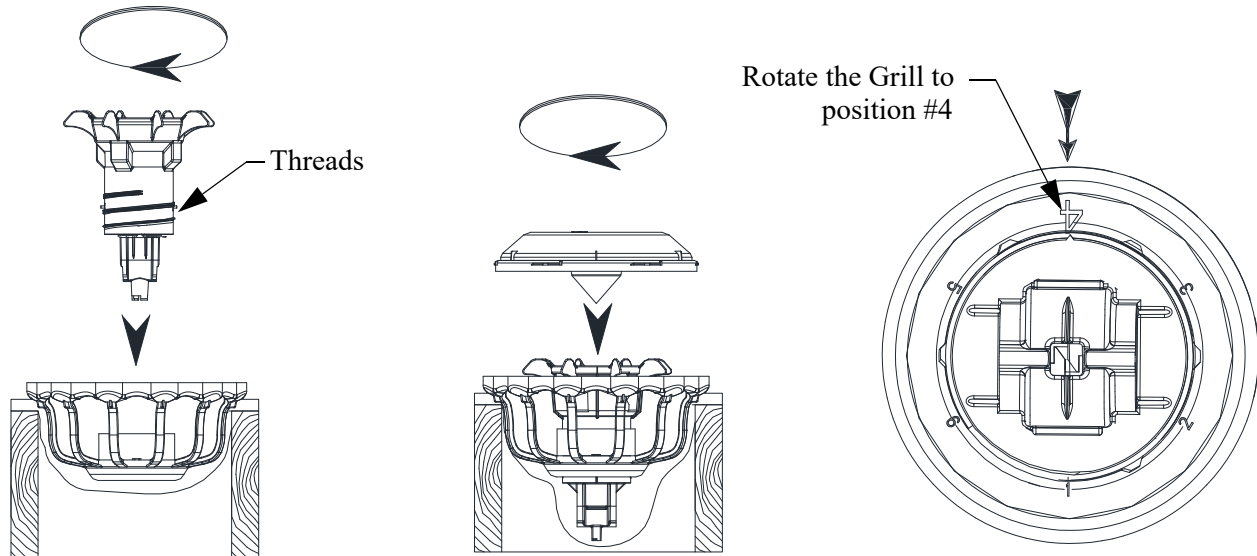

Figure 24. Pan Assembly Option 1

### Pan Assembly Procedure for (Not using Box)

1. Place cone assembly on a flat surface.
2. Set Grill over the Cone.
3. Rotate the Grill until the threads are started. Do not cross thread
4. Continue rotating the Grill until you reach **position 4**.
5. Turn the assembly over and install the Pan by rotating the Pan until it latches.

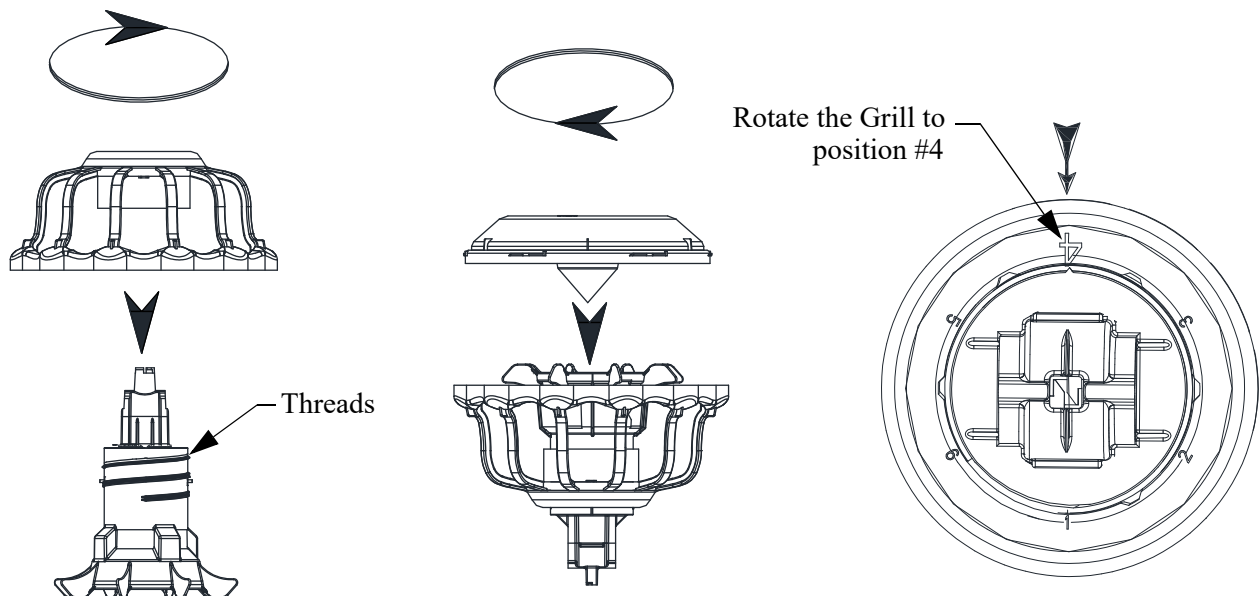

Figure 25. Pan assembly option 2



## Feeder Line Assembly and Suspension

### Feeder Pan and Tube Assembly Process

- Slide one Feeder Pan Assembly per hole onto the auger tubes.  
**IMPORTANT:** Install all the feeders on the tubes in the same orientation.  
 When sliding the feeders on the tubes, make sure are on the same side of the tube.
- Rotate the auger tubes so that the seam is down, this holds the Pan Assemblies in place on the tubes.

### Assemble and Suspend the Feeder Line

- The actuator, auger tubes and feeders may be laid out end to end in approximately the final location of the line. **The belled end of each tube should be toward the (3) Hopper end of the line. See Figure 26.** Be sure to have the correct number of tubes and the actuator is in the center of the section to be controlled by an actuator.
- Connect the individual feeder tubes together by inserting the straight end of one tube as far as possible into the (2) belled end of the next tube. **The last Feeder Tube before the (1) End Control Pan or Mid Line Control pan must be a Control Tube.**

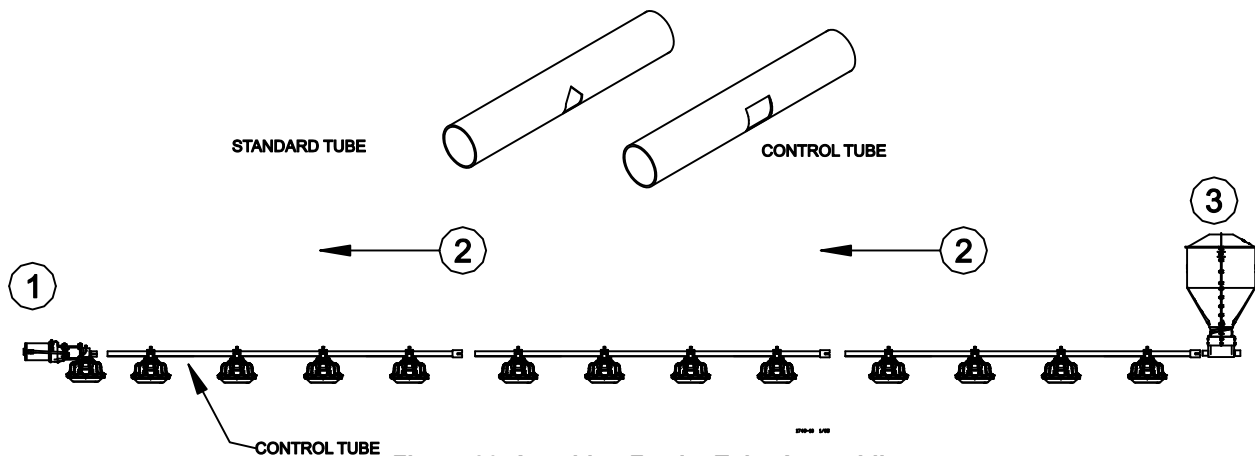

Figure 26. Attaching Feeder Tube Assemblies

- To achieve total feed drop out all along the system, the Chore-Time Logo should be centered at the crown of the tubes and all the Hangers should be installed as shown in Figure 27.

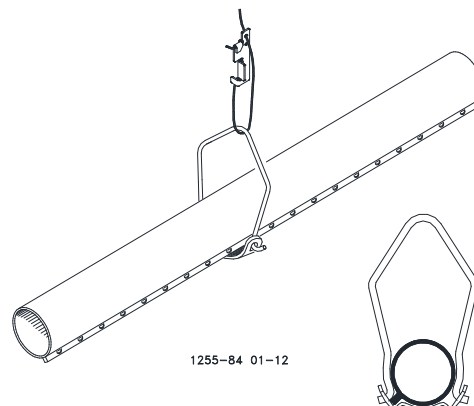
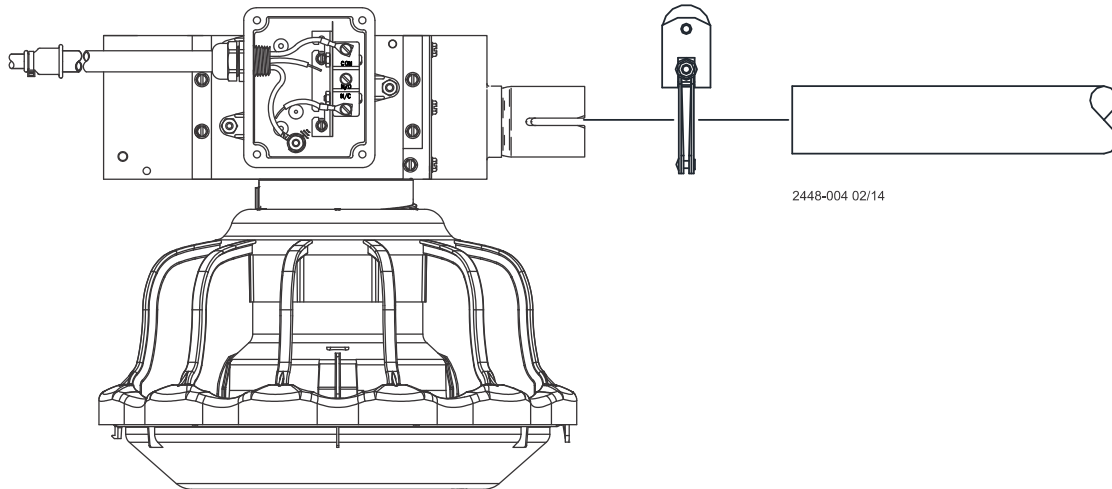

Figure 27. Hanger Installation

## End Control and Boot Assembly Installation

Install a control tube just before the end control. The End Control Unit must be at least 10 feet [3 m] from the end of the building to allow birds access around the end of the feeder line.

1. Assemble the End Control Unit to the Feeder Line Control Tube using a clamp/anti-roost bracket. See **Figure 28**. **DO NOT INSTALL THE POWER UNIT AT THIS TIME.**



**Figure 28. Connecting End Control Unit to the Feed Line Tube**

2. Install the Feeder Boot by sliding the straight end of the Feeder Boot into the belled end of the Feeder Tube. Install a clamp/anti-roost bracket on the bell and tighten. The Feeder Boot must be level with the feeder line and the open top of the Feeder Boot must be horizontal. See **Figure 29**. **DO NOT INSTALL THE ANCHOR BEARING AND BEARING RETAINER AT THIS TIME.**

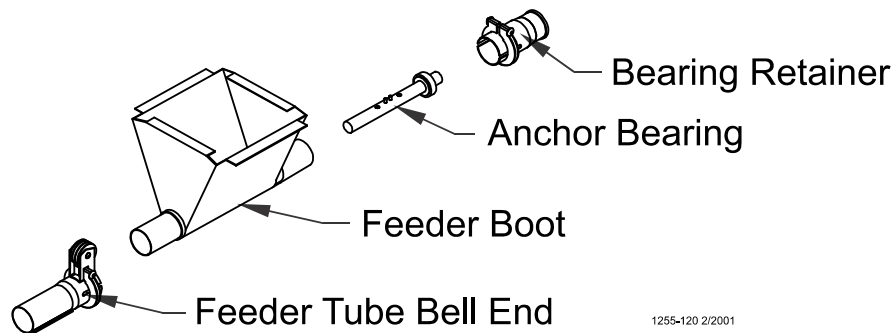

**Figure 29. Installing the Feeder Boot**

# Auger Installation

**Note:** Use extreme caution when working with the auger. The auger is under tension and may spring causing personal injury. Wear protective clothing, gloves, and safety glasses when working with the auger.

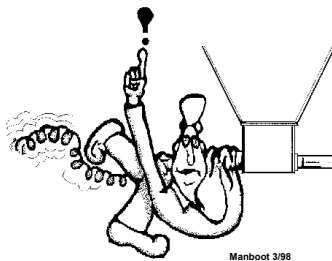

**BE CAREFUL WHEN WORKING WITH THE AUGER!**

To avoid kinking the auger, be careful not to drop the rolled auger when handling. Inspect the auger carefully as it is installed. Small kinks may be straightened. Large kinks must be removed and the auger brazed back together.

Cut the leading 18" [450 mm] and last 18" [450 mm] off each roll of auger. Also, cut out any other distorted auger sections and reconnect the auger as specified in the Auger Brazing section of this manual.

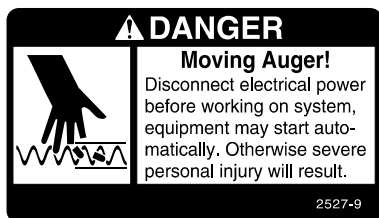

1. Use extreme caution when pushing the auger into the auger tubes. Keep your hand away from the end of the auger tube to avoid injury.  
 With the auger coiled about 6 feet [1.8 m] from the end of the boot, uncoil the auger from the outside and feed the auger through the boot into the tubes.  
 Push the auger into the tube in short strokes.  
 Uncoil and handle the auger carefully to avoid damaging or kinking the auger.
2. If more than one coil is required for each feeder line, the auger ends will have to be brazed together. Refer to the Brazing the Auger section in this manual.
3. Install the Anchor Bracket to the Power Unit/Gearhead, as shown in **Figure 30.**, with the included 5/16-18 Bolts.

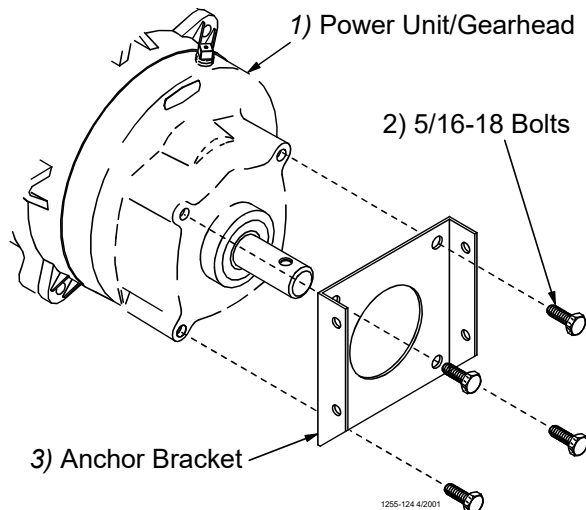

**Figure 30. Assemble the Anchor Bracket to the Power Unit/Gearhead**

4. Slide the Drive Tube and flat washer over the output shaft on the Power Unit, as shown in **Figure 31**.
5. Continue installing auger until the auger reaches the Control Unit end of the feeder line.
6. Turn the Drive Tube Weldment into the auger, then attach to the output shaft of the Power Unit, as shown in **Figure 31**. Use the Driver Block to secure the auger to the Output Shaft.

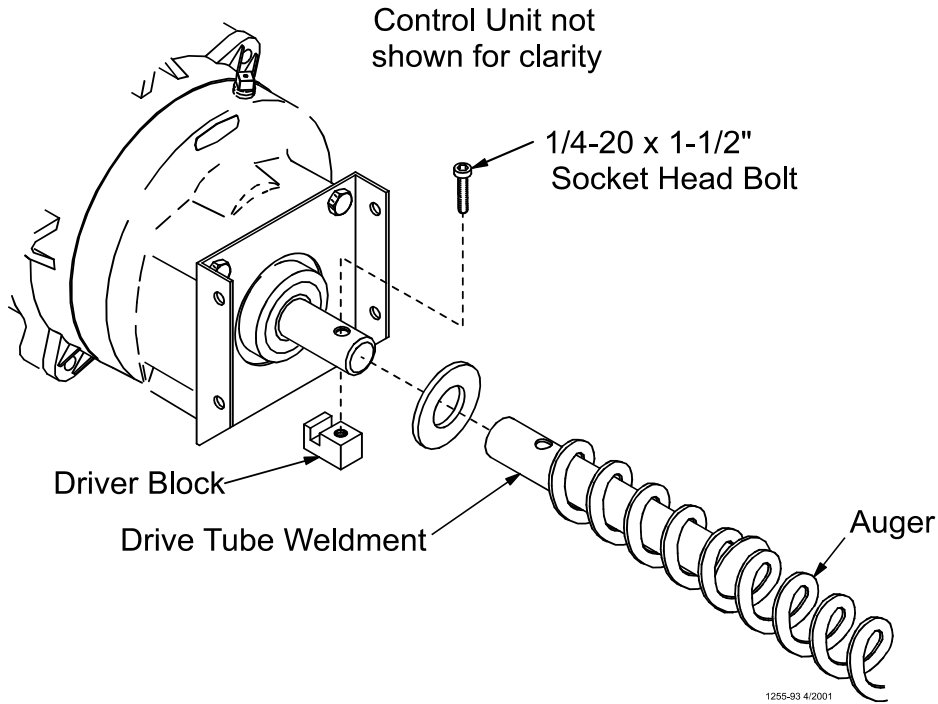

**Figure 31. Auger Driver Components**

7. Attach the Anchor Plate and Gearhead Assembly to the Control Unit Body using the included 1/4" Lock Washers and 1/4-20 x 1/2" Bolts. See **Figure 32**.

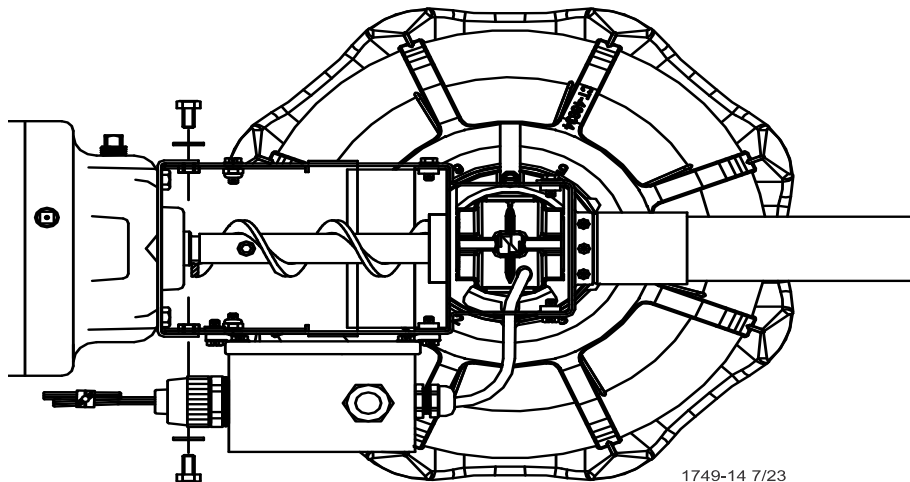

**Figure 32. Attaching the Anchor Plate and Gearhead Assembly to the Control Unit Body**

8. Install the Metal Water Tight Connector (**Item 1**) in the Feed Line Motor (**Item 2**). Cut the Flex Conduit (**Item 3**) to length. Slide the wires from the end control through the Flex Conduit (**Item 3**). Install the Flex Conduit. Connect the wires to the Feed Line Motor (See **Figure 33**).

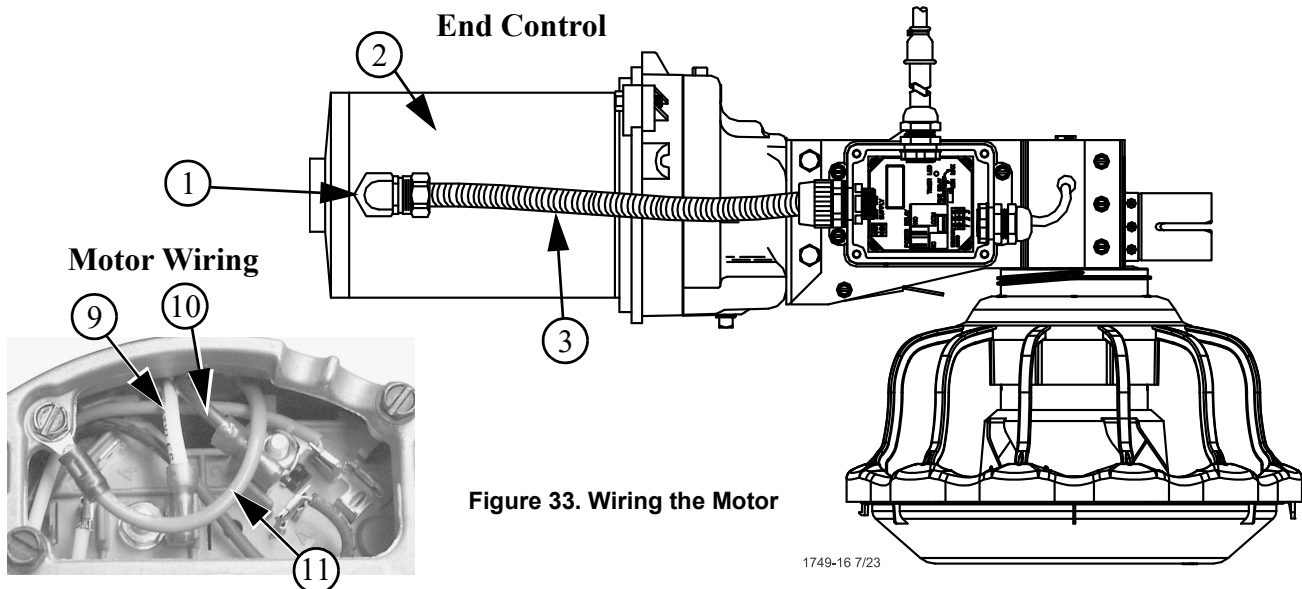

Figure 33. Wiring the Motor

1749-16 7/23

9. Attach all covers and wire according to the wiring section of this manual.
10. Pull the auger at the boot end until it begins stretching. Then let it relax. In the *relaxed* position, mark the auger at the end of the boot. See **Figure 34**.
11. Auger stretch:  
The auger needs to be stretched 7" [180 mm] per 100' [30 m]. Example: A 300' [90 m] feeder line requires 21" [500 mm] of stretch.  
Beginning at the *relaxed* position, measure the required amount of stretch. Mark the auger at that point.  
Grip the auger 8" [200 mm] ahead of this mark with locking pliers. Allow the auger to pull back into the boot so that the pliers rest against the end of the boot. See **Figure 35**.

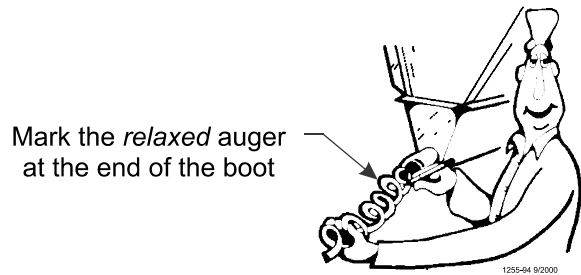
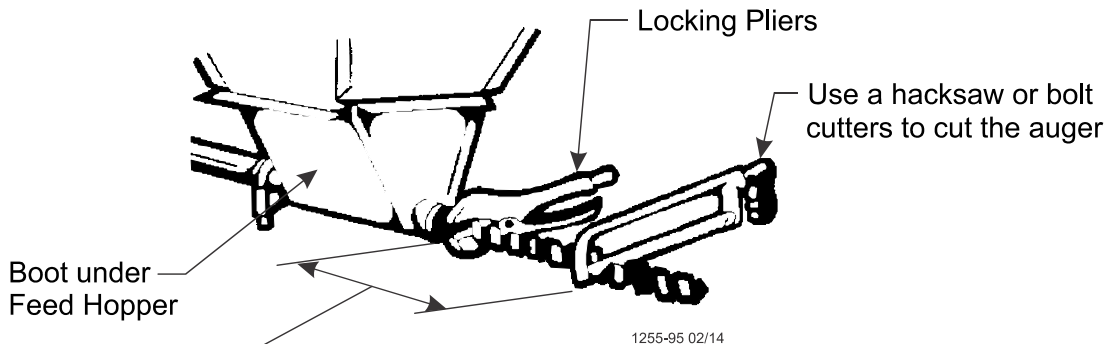

Figure 34. Measure Auger from Relaxed Position

1255-04 9/2000

Use a hacksaw or bolt cutters to cut the auger at the stretched auger mark.



1255-95 02/14

Pull an extra 8" [200 mm] of auger (minimum) to allow for Anchor and Bearing Installation

Figure 35. Cut the Auger with required stretch Position

12. Insert the Anchor Assembly into the auger until it touches the washer at the back of the anchor. Tighten the Set Screws in the center of the anchor until they touch the auger, then tighten a maximum of 1/2 turn. See **Figure 36**.

**Important! Do Not overtighten Set Screws.**

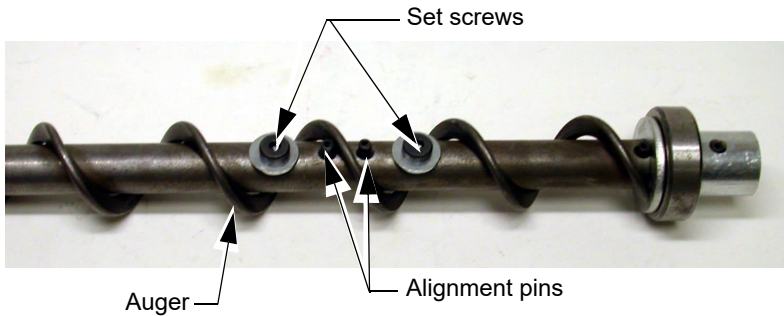

**Figure 36. Auger and Anchor Bearing Connection**

13. **Carefully** remove the locking pliers while holding onto the Anchor and Bearing Assembly and auger securely. **Slowly** ease the auger back into the tube. Use caution. If the auger is allowed to spring back, the bearing race may crack. Install the Bearing Retainer and fasten with a tube clamp. Keep the Bearing Retainer flush with the end of the anchor for safety.
14. Place the cannon ball in the boot.

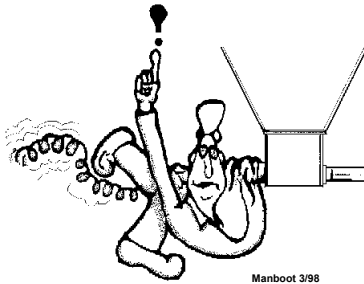

**BE CAREFUL WHEN WORKING WITH THE AUGER!**

**Auger Brazing**

The auger should be brazed if it is necessary to splice or lengthen it. A bronze, flux coated rod is recommended. The ends of the auger should butt against each other, **DO NOT THREAD INSIDE EACH OTHER.** (See **Figure 37**). The joint should be well filled with no sharp edges or rough corners to wear against the tube. To align the auger for brazing, lay it in angle or channel iron and clamp it firmly in place. Use low heat. Allow the joint to air cool; rapid cooling will cause the auger to become brittle.

Lap the auger ends approximately 1" [25 mm]

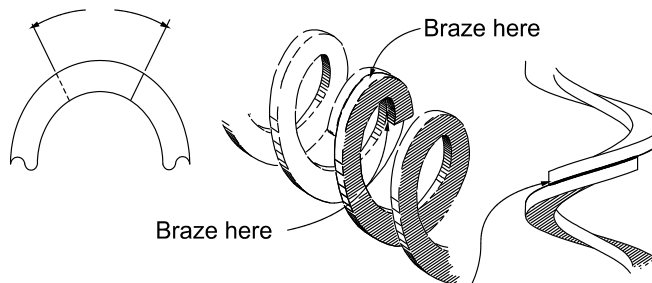

Butt the auger ends together  
DO NOT thread the auger together

**Figure 37. Auger Brazing**

## Mid-Line Control

Mid-Line Control Units are available for the FF Revolution 8 & 12 Feeders. The Mid-Line Controls are shown in **Figure 38**.

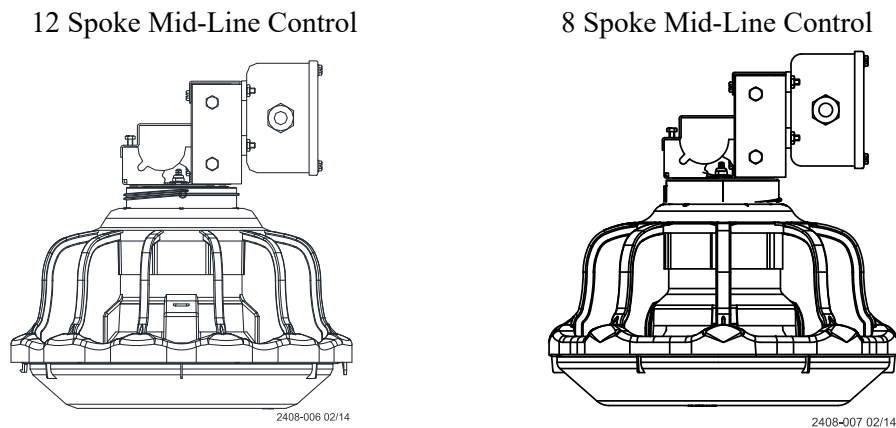

**Figure 38. Mid-Line Controls**

The Mid-Line Control makes it possible to operate the feeding system when birds are confined away from the End Control Unit. Chore-Time recommends placing the Mid-Line Control Feeder at least 2 pans away from the curtain or partition, **Figure 39**.

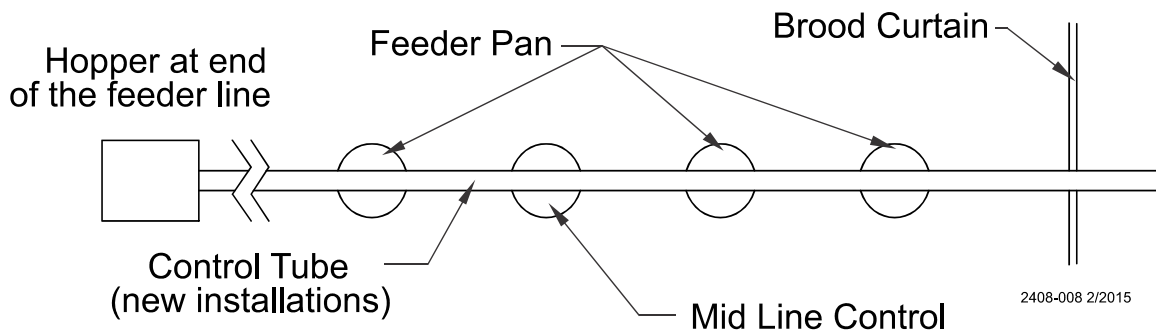

**Figure 39. Mid-Line Control Location Diagram**

### New Feeder Lines

1. Install a control tube for the Mid Line control. The feeder line can be assembled and suspended before attaching the Mid-Line Control; or the Mid-Line Control may be attached to the Feeder Tube when the other pans are installed. The Mid Line control should be installed on the last hole in the Control Tube.
2. Install a toggle switch, out of reach of the birds, to disconnect power to the Mid-Line Control. This allows the Mid-Line Control to serve as standard feeder when not used as a Control Feeder.
3. Wire the Mid-Line Control as shown in the wiring diagram section of this manual.

## Existing Feeder Lines

1. Cut the Grill Support and remove the feeder pan at the location where the Mid-Line Control will be installed
2. Enlarge the outlet hole to approximately 1" [2.5 cm] diameter for the Mid-Line Control, plus enlarge (2) outlet holes in front (to the hopper end) of the Mid-Line Control.
3. Use unibit to enlarge hole size. Be sure there are no burrs inside the tube to catch the auger.
4. **Mechanical Switch:**
  - a. Assemble the Mid-Line Control over the outlet hole in Tube as shown in **Figure 40**.
  - b. Attach the Mid Line Control to the tube using the clamp on lid, and secure with the 10-24 screw supplied.
5. Install a toggle switch, out of reach of the birds, to disconnect power to the Mid-Line Control. This allows the Mid-Line Control to serve as standard feeder when not used as a control feeder.
6. Wire the Mid-Line Control as shown in the wiring diagram section of this manual.

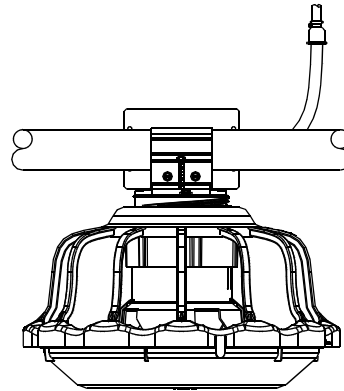
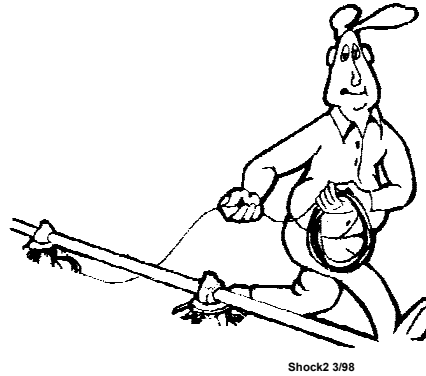

Figure 40. Installing the Mechanical Mid Line Control



## Anti-Roost Installation

1. Unroll the bulk anti-roost cable. Note: If the cable is unrolled as shown in **Figure 41**, taking 5 loops of the coil with one hand, then changing hands to remove 5 loops as it is unrolled, it will lie flat during installation.



Shock2 3/98  
Figure 41. Unrolling the Cable

2. Start at the hopper end of the line and form a loop around the anti-roost bracket. For best results, make a double loop around the anti-roost insulator in the center groove of the insulator and fasten with a 1/16" cable clamp as shown in **Figure 42**.
3. Insert the cable in the insulator on the top of each Grill Support between the hopper and the next anti-roost bracket.
4. Attach a spring in the center groove at the second anti-roost bracket and cut the cable at this point. See **Figure 43**.

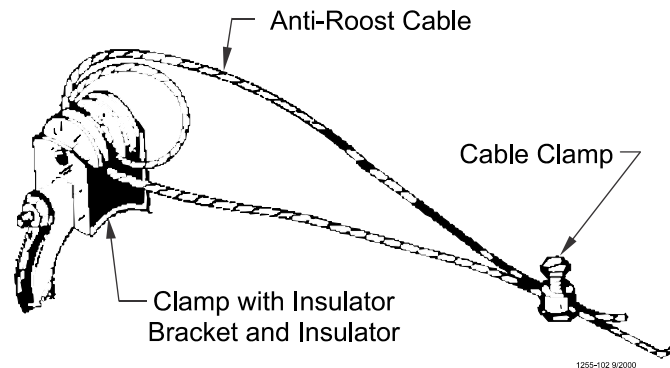

1255-102 9/2000  
Figure 42. Anti-Roost Cable at the Hopper

5. Thread the ends of the cable through the end of the spring. Pull the cable tight so that there is 3/4" to 1" [20 to 25 mm] of stretch in the spring. Clamp the cable to form a loop and cut off any excess. See **Figure 43**.
6. Attach the cable to the insulator. For best results, make a double loop around the anti-roost insulator in the center groove of the insulator and fasten with a 1/16" cable clamp as shown in **Figure 43**.

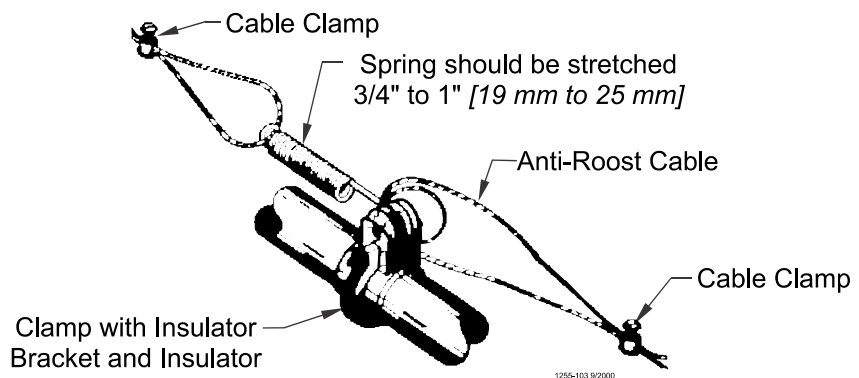

1255-103 9/2000  
Figure 43. Anti-Roost Cable Mid-Line Connection

7. Run the cable to the next insulator, attach a spring in the center groove at the anti-roost bracket and cut the cable at this point. The cable should be positioned in the insulator built into the top of each grill support along the feeder line.
8. Repeat this installation until the anti-roost cable is installed along the entire feeder line.

9. At the control unit, after clamping the cable to the spring, cut the cable about 8" to 10" [200 to 250 mm] longer than necessary. Feed the end of the cable through the center of the spring, around the first insulator on the control unit, and clamp the cable using the cable clamp supplied with the control unit. See **Figure 44**.
10. Install the wire form on the control unit insulators. Be sure the guard snaps into the retainers molded into the insulators. See **Figure 44**.

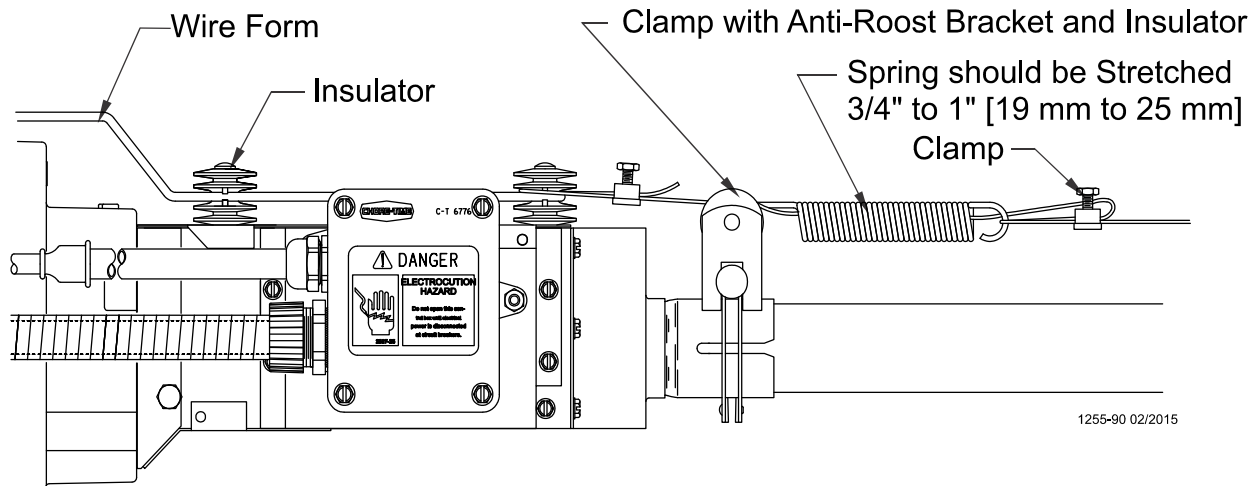

**Figure 44. Anti-Roost Installation at the Control Unit**

11. Install the Poultry Trainer or Line Charger, as shown in **Figure 45**. The Poultry Trainer is used to power all Anti-Roost lines in a house. The Line Charger is used to power individual Anti-Roost lines in a house. See **Figure 45**. Route the charger wire from the Poultry Trainer or Line Charger to the Anti-Roost system. Secure the Charger Wire to the Anti-Roost cable, using a cable clamp.

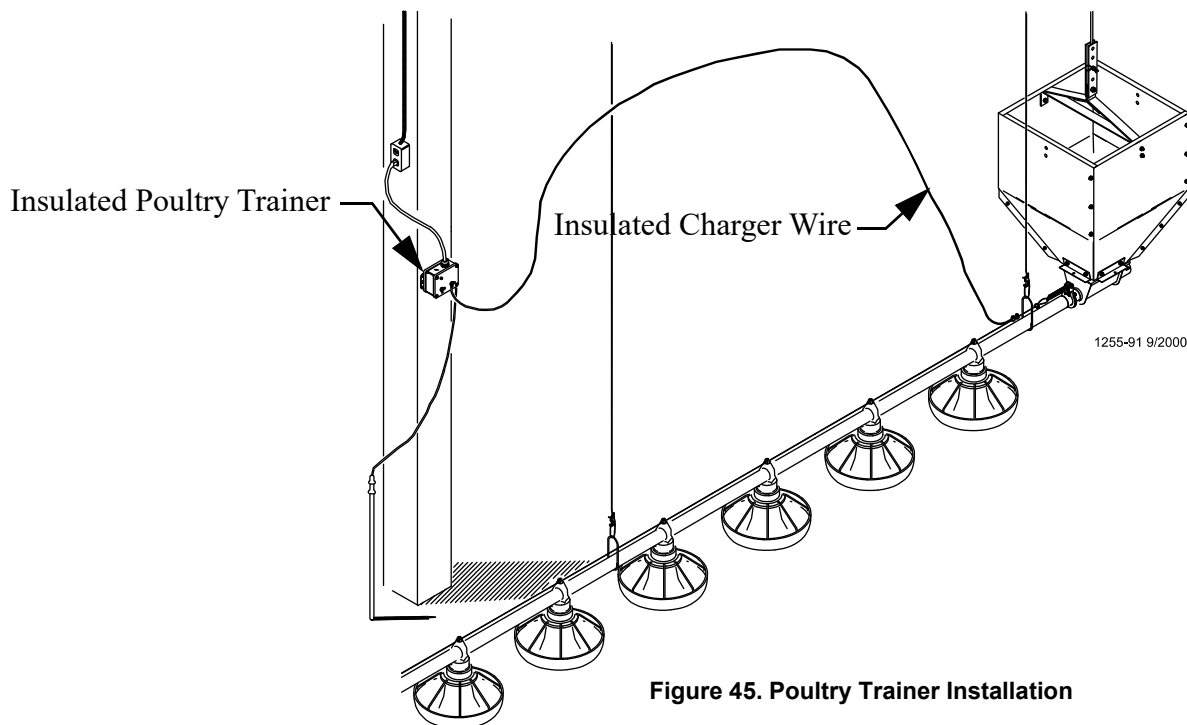

**Figure 45. Poultry Trainer Installation**

12. The **anti-roost system** *must* be on a **separate electrical circuit**, allowing the system to be disconnected by a **switch near the door**. Remember, the anti-roost system should be **grounded through the poultry trainer**.

## Electro-guard Operation

The electro-guard chargers should be operated on a separate electrical circuit so the anti-roost system can be shut off using a switch next to the entrance door when someone enters the building. Birds are less likely to become wild and flighty if the anti-roost is off when people are in the building.

# Feeder Management and Operation

This section provides you with valuable information concerning Feeder operation and management. It is important that you read this information and understand how the feeding system was designed to operate. Once you become familiar with the system, you may *custom operate* it to fit your individual needs.

## Initial Start-up of the Feeding System

The Feeding System should be operated prior to birds being housed to make sure the installation is correct, the switches function properly, and to fill the Feeder lines with feed.

There are two typical layouts for the feeding system that was determined prior to the installation. Normally if the building is 400' [122 m] or over, a center house hopper set-up is used, see **figure 46**. For buildings under 400' [122 m], the hopper is placed at one end and the control pan/power unit at the other end, see **figure 47**.

It is common practice to use partial house brooding during the early days of broiler production. For buildings that have the Feeder split in the center (center hopper set-up), normally only the Feeders that are in the brood area are used during brood time. For buildings that have the hopper at one end, brooding can be done on the motor end or an optional mid line control pan(s) can be placed on the Feeder line.

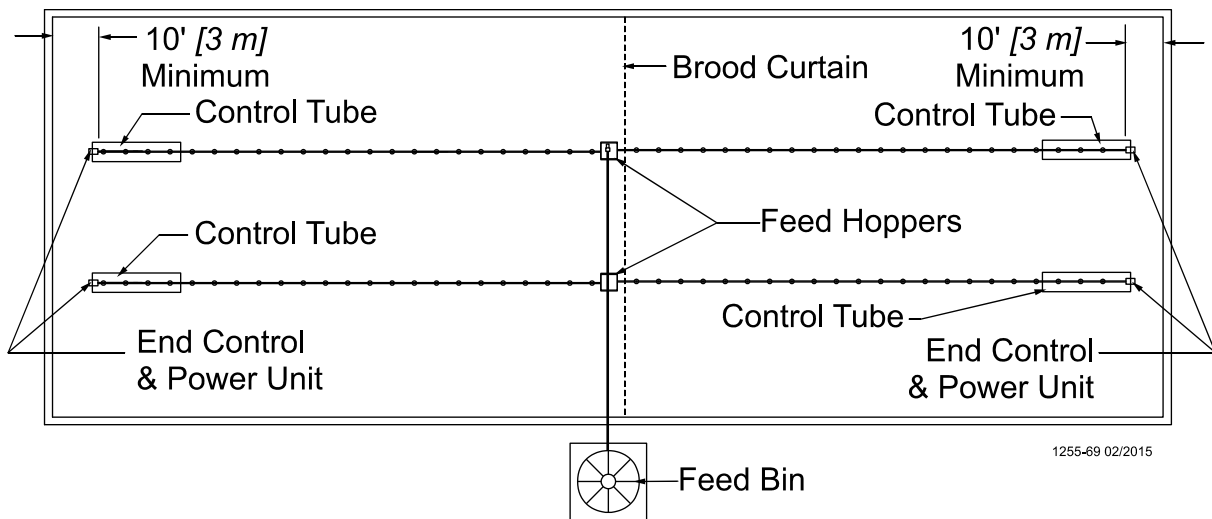

Figure 46. Component location diagram for systems over 400 feet [122 m]. (Top View).

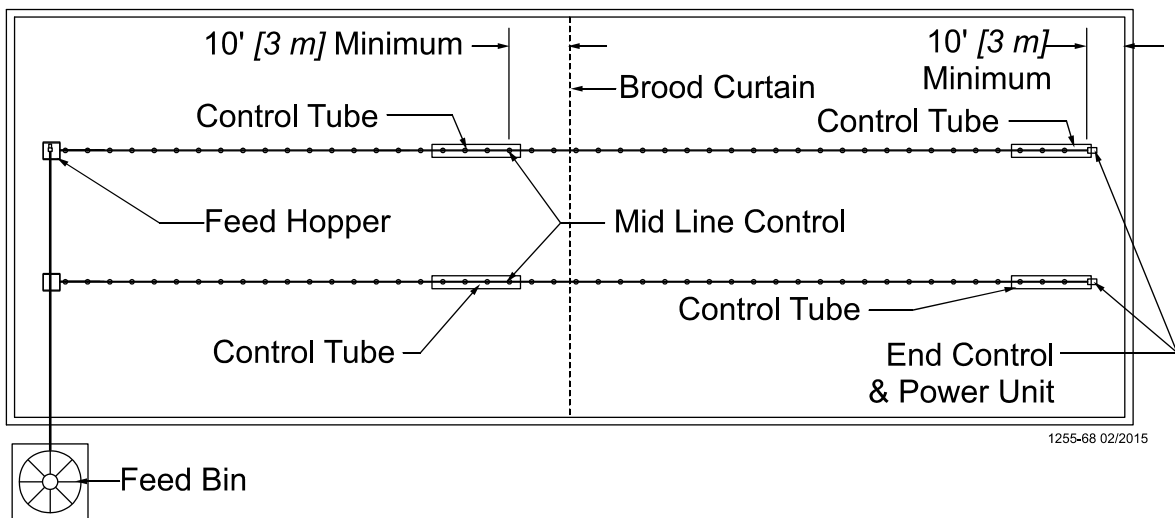

Figure 47. Component location diagram for systems up to 400 feet [122 m]. (Top View).

The Feeder Tubes and auger are supplied from the factory with a protective oil coating that will cause the system to deliver feed at a reduced rate. The oil coating will also create a larger load on the power unit (motor) until the system has been initially purged with feed, and becomes broken in.

To operate

1. Lower Feeder lines so the feed pans are resting on the floor and the feed flood windows are completely open. Although the major weight of the Feeder lines will be on the floor, do not remove all the weight from the suspension system and allow the cables to become slack.
2. Apply power to the Feeder lines to check the operation. Allow to operate empty for 1-2 minutes.

**NOTE: For Feeder lines that have mid line controls, the recommended bypass switch(s) are wired into the system for selection of partial or full house control. Select the switch so the mid line control is functional. As the Feeder operates, the feed will stop at the mid line control pan.**

3. With the shut-off slide on the feed bin boot closed, energize the Flex-Auger® fill system. After operation of approximately 1-2 minutes, open the boot slide 1-2" [2.5-5 cm] to allow feed to be conveyed to the Feeders.
4. Once feed begins to be dispensed into the feed hopper(s), manually shut-off the fill system.
5. Apply power again to the Feeder lines. Operate the fill system manually to dispense approximately 50 lb. [23 kg] increments of feed into the feed hopper(s). Allow the feed hopper to become empty for 30 seconds between each increment to reduce load on the Feeder Motor. Continue this procedure until feed has been dispensed to all the Feeder Pans. When the feed reaches the control pan, the Feeder line will be shut-off.
6. Once the Feeder lines have been initially filled with feed, manually dispensing feed in 50 lb. [23 kg] increments will no longer be necessary. **The shut-off slide on the Flex-Auger® fill system must be completely opened.** Refer to the Flex-Auger fill system Operator's Manual for information when multiple feed bins are used.

## General Operation of the Floor Flood Revolution® (FFR) 8 and 12 Feeders

These recommendations are the guideline to aid producers with the use of the feeding system. With experience a feeding program will be developed to enhance the feeding systems performance. Several factors such as feed content, type of birds, climate, lighting programs, and etc. may dictate change from these recommendations.

The FFR Feeders have a floor flood brood feed opening which allows the Feeder Pan to be flooded with feed which is desired for starting young birds. Start young birds with the Feeder locked in the fully. To lock the Feeder in the fully open position slide the Feeder up on the Cone and twist clockwise until it is locked into the position

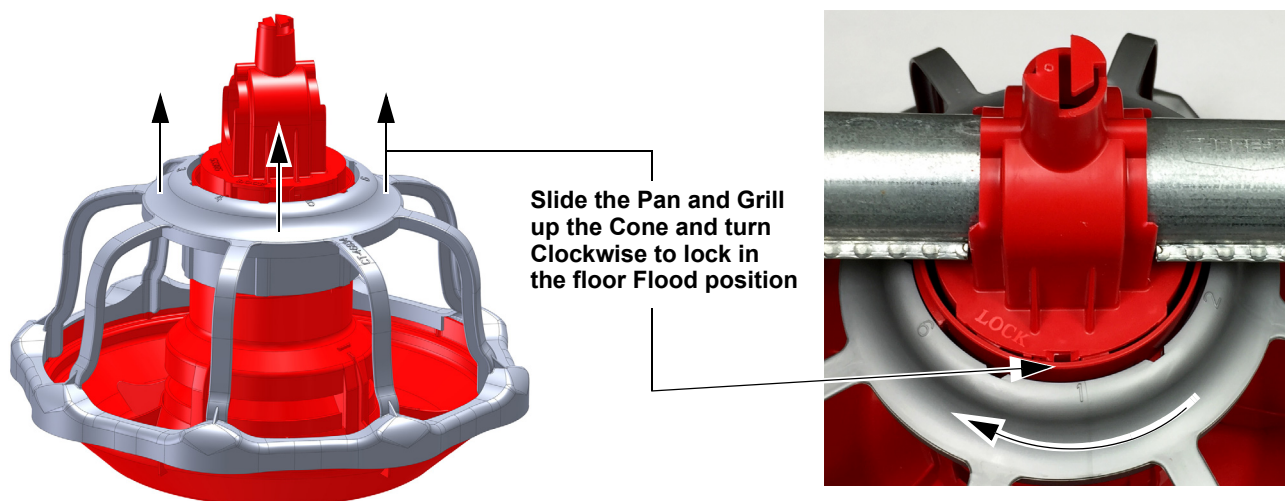

Figure 1. Component location diagram for systems up to 400 feet [122 m]. (Top View).

Although the major weight of the feeder lines will be on the floor, do not remove all the weight from the suspension system and allow the cables to become slack.

It is advisable to provide supplemental feed during the first few days for the young birds. This is especially true when partial house brooding is used See **“REVOLUTION® Feeding System Operation Guide ” on page 31.** Supplemental feeders such as the CHORE-TIME® E-Z START™ Chick Feeder, provide extra feeding space and access to the feed.

With the feeders lowered to the floor and the brood openings, the operation of the feeder will allow a high level of feed to be placed into the feed pans making it easy for the birds to find feed, adapt to the feeder, and begin to eat.

The floor flood should not be operated on a time clock while the windows are open. Chore-Time recommends the brood opening be fully open for the first 2 days. The setting should be reduced on the 3rd, 5th, 11th then closed on the 14 to 17 day. Again on the 5 day time clock should be utilized to limit the number of times and length of time the feeder can operate. Failure to do one of the above will create the possibility of an excessive high feed level in the feed pans and the birds to waste feed.

As the birds grow and become acclimated to the feeder pans, the feeder will need to be raised to the grow-out position. Before moving the brood opening, it is recommended to allow the birds to eat the feed level down below the feed fin. This will ease the process of the feed flood windows closing properly.

Use the suspension system to raise the feeder(s) line. Raising the feeder will close the brood opening. Continue raising the feeder lines until the feed pans just begin to clear the floor or litter.

## Feeder Setting

**The feeder should be set on the #4 position for most applications.** The adjustment settings are easy to understand and change. Setting numbers are embossed on the top of the grill so they may be easily seen, see **figure 48.** Spin the Grill to line up the desired numbered position with the arrow on the Cone.

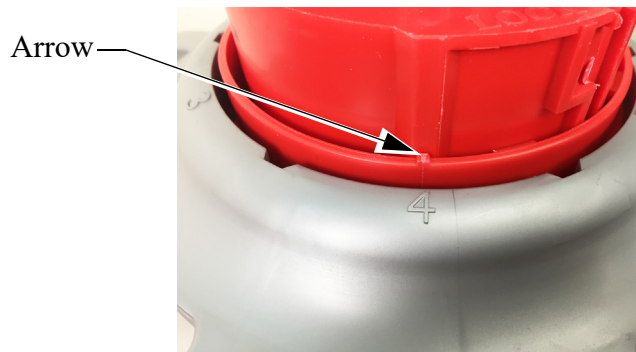

Figure 48. Setting Feeder Position

Feed texture and consistency, type of bird, or other variables may make it necessary to change to another feed setting position. The combination of proper pan height, feeder setting, and feeder operation will result in optimum feeder performance. The operator will learn what performs best for his/her situation with experience.

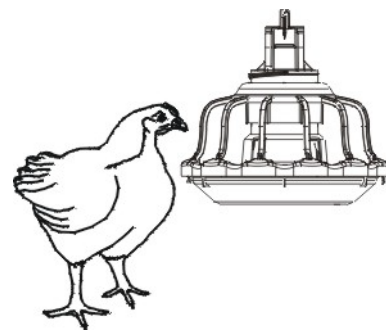

Figure 49. Feeder Pan Assembly height adjustment

## REVOLUTION® Feeding System Operation Guide

### One - two days prior to housing chicks

1. Lower feeding system so pans are resting on the litter.
2. Completely open all feed windows.
3. Operate feeding system on brood end of building to fill feed pans and chick trays.

### Day one - Day 4

1. Observe feed level in feeder pans approximately 6 hours after birds were housed. Activate the feeder control pan manually to allow feeder to refill feed pans (if needed).
2. At day 2, observe feed level in feed pans, if the birds have not activated the control pan(s), do so manually.
3. At day 3-4, begin to close feed windows from setting.

### Day five - Day 7

1. Depending on feed level and bird activity, close windows.

### Day 10 – 12

1. If litter under feeders becomes concave and the birds are reaching over to get feed, raise feeder lines to where the pans just clear the litter.
2. Prior to opening the grow-out end of building to move the birds, operate the feeders (windows open).
3. Once the birds have been released to the grow end of the building, close feed windows on grow-end feeders to equal the setting of the Brood-end (setting #5).

### Day 16

1. Raise feeders so pan/grill edge lip is approximately 4 inches [10.1 cm] off the litter.
2. Close feed windows.

### Day 18 - 20

1. Close all feed windows

### Day 20 – end of flock

1. Raise feeders as needed.

This is a general operation guideline for the FF REVOLUTION® Feeding System. Bird activity and feed flowability will have a direct effect on the feed level with-in the feeder pans. Operator judgement of actual on site conditions may require modification to the operation guideline.

## End Control and Mid Line Control Pans

At installation time, the end control pan of the Feeder was placed to be 10 feet [3 m] from the end of the building to allow the birds access around the end of the feeder line. It is important the feed setting of the End Control Pan be the same as the rest of the feeder pans so the birds activate the Feeder. The Mid Line control is placed on the Feeder line when partial house brooding is desired. It is important the mid line control be installed at least 2 Feeder pans away from the curtain or partition so the birds will activate the Feeder line. The feed setting for the Mid-Line Control should be the same as the rest of the Feeder Pans on the Feeder line (**information**). A toggle switch or disconnect is used to bypass the power to the mid line control. This allows the mid line control to serve as a standard Feeder after brooding. The Feeder can be changed from full house operation to partial house brooding with the activation of the switch.

## Controlling the Feeders (optional equipment)

A time clock control is used with the feeding system to reduce excessive Feeder operation time and limit feed wastage. The basic use of a time clock control is to allow periods of time during the day for the birds to reduce the feed level in the Feeder Pans and to limit the possibility of the birds creating a high feed level and wasting feed. This is not to be confused with lighting programs that have become very common place. If lighting or intermittent lighting programs are to be used, the use of the time clock control will be limited to just the light period. **Caution should be used to not restrict the feed from the birds during the light period.** Experience with the feeding system will determine how the time clock control is used.

The FF Revolution 8 and 12 Feeding Systems may be controlled by the #34385 Control Panel or the #34574 Time Clock Control. Refer to the instructions supplied with each control for information.

## Maintenance

### Floor Feeding System Maintenance

The FF REVOLUTION® Feeder require's minimum maintenance. However, a routine periodic inspection of the equipment will prevent unnecessary problems.

Maintenance should be done by a qualified technician.

**ALWAYS DISCONNECT POWER TO THE SYSTEM WHEN SERVICING OR MAINTAINING THE EQUIPMENT. FAILURE TO DISCONNECT POWER MAY CAUSE INJURY OR DEATH.**

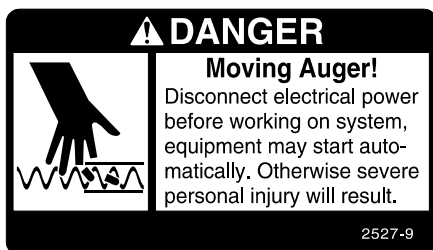

### Gear Head Maintenance

Refer to **Figure 50**.

Check the oil level in the gear heads at installation and every 6 months. The Pipe Plug, on the side of the gear head, indicates proper oil level. Add SAE 40W oil when necessary.

The oil in the gearheads should be replaced every 12 months with new SAE 40W oil

- A. Remove the bottom Pipe Plug to drain the oil. Discard used oil in accordance with local and national codes.
- B. Wipe any debris off the magnet on the bottom Pipe Plug and reinstall. Remove the side Pipe Plug and (top) Vent Plug.
- C. Set the power unit in the horizontal position.
- D. 2-Stage Gearheads: Add approximately 9 oz. (266 ml) of SAE 40W oil through top hole. This should be just enough oil to reach the side Pipe Plug.  
3-Stage Gearheads (3261-9, 3261-12, 3261-14): Add approximately 13 oz. (384 ml) of SAE 40W oil through top hole. This should be just enough oil to reach the side Pipe Plug.
- E. Install the side Pipe Plug and (top) Vent Plug.

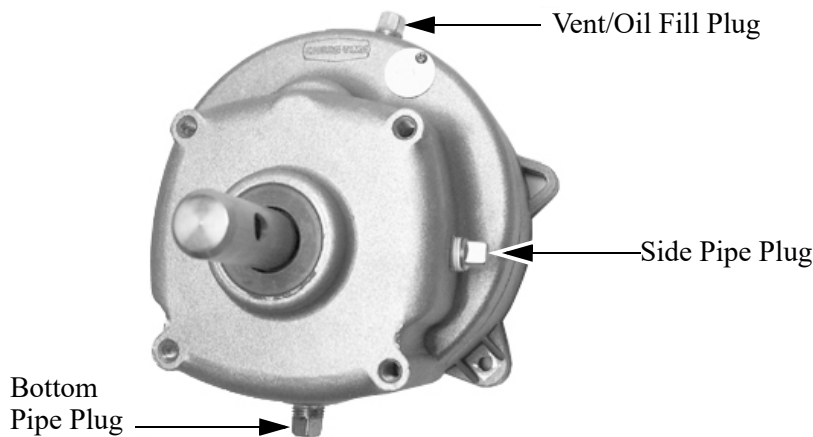

**Figure 50. Gearhead Maintenance**

### Hardware Check

Check equipment for loose hardware after the first flock and then every 6 months--including the Anchor Block.



## Feeder Line

Keep anti-roost cables tightly stretched. This increases the effectiveness of the electro-guard anti-roost system and keep the pans from being tilted when birds push against them.

Remove all feed from the feeder when there are no birds in the house and when the building is washed and disinfected.

Turn the feeders off prior to removing the birds from the house. This will allow them to clean the feed out of the pans.

If the system is not to be used for an extended period of time, remove all the feed from the feeder lines and feeder pans.

Disconnect power to the system to prevent accidentally starting the system.

If the system must be disassembled, extreme caution must be used to prevent injury from springing auger.

1. Disconnect power to the entire system.
2. Loosen the Tube Clamp on the bearing at the hopper end of the system. Remove the Tube Clamp and Bearing Retainer.
3. Pull the Anchor and Bearing Assembly and approximately 18" [45 cm] of auger out of the boot.

**CAUTION: Stand clear...the auger may spring back into the tube.**

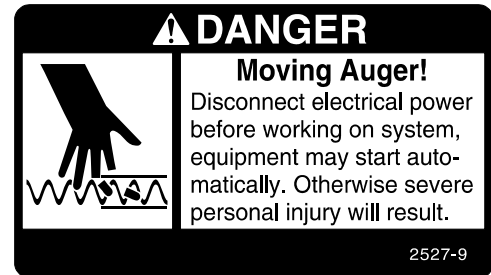

4. Place a clamp or locking pliers securely on the auger to prevent it from springing back into the auger boot.
5. Loosen the setscrew in the bearing assembly shaft and remove the Anchor and Bearing Assembly from the auger.

### To reinstall the Anchor and Bearing Assembly:

1. Insert the Anchor Assembly into the auger until it touches the washer at the back of the anchor. Tighten the setscrews in the center of the anchor until they touch the auger, then tighten a maximum of 1/2 turn. See **Figure 51**.
2. **DO NOT OVERTIGHTEN THE SET SCREWS.**
3. **Carefully** remove the locking pliers while holding onto the Anchor and Bearing Assembly and auger securely.  
**Slowly** ease the auger back into the tube. Use caution. If the auger is allowed to spring back, the bearing race may crack.

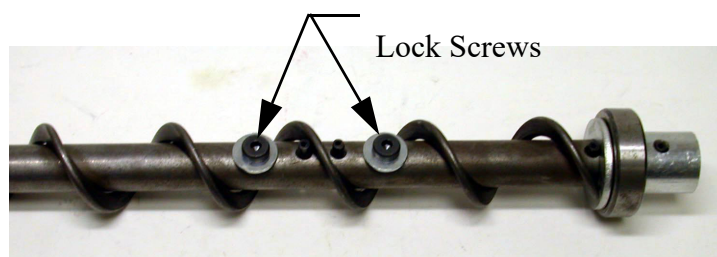

**Figure 51. Auger and anchor Bearing Connection**

Install the Bearing Retainer and fasten with a tube clamp. Keep the Bearing Retainer flush with the end of the anchor for safety.

## Power Lift Winch Maintenance

Refer to **Figure 52**.

Grease the winch every 6 months with 1 to 2 shots of common industrial or automotive grease.

**DO NOT OVER GREASE THE WINCH.**



Grease the Power Lift Winch every 6 months with one or two shots of common industrial or automotive grease. **DO NOT** over grease!

**Figure 52. Maintenance to the Power Lift Winch**

Remove any feed build-up in the Safety Switch Boxes in the Control Units.

It may be necessary to periodically re-tighten the shocker cable. Be sure to disconnect power to the shocker before servicing the equipment.

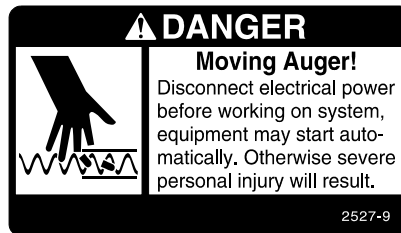
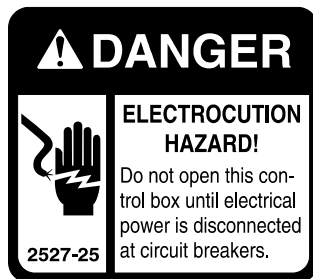

## Trouble Shooting the Floor Feeding System

ALWAYS DISCONNECT POWER TO THE SYSTEM WHEN SERVICING OR MAINTAINING THE EQUIPMENT. FAILURE TO DISCONNECT POWER MAY CAUSE INJURY OR DEATH.

Service and maintenance work should be done by a qualified technician only.

Problem	Possible Cause	Corrective Action
None of the feeder lines will operate	No power supplied to equipment	Replace burned fuses or reset circuit breaker Make sure voltage required is supplied
	Time Clock or relay defective	Replace Time Clock or relay
	Time Clock improperly programmed	Refer to Programming the Time Clock section and reprogram the Time Clock
Feeder line will not operate	Power unit cord not plugged in sufficiently to make contact	Check motor cord plug at control unit and control unit plug at outlet for connection
	Motor cord wires are broken at plug or where cord enters motor	Check cord for continuity Replace if defective
	Power Units thermal overload tripped	Push motor overload reset button to reset
	Control unit switch defective or out of adjustment	Adjust switch according to the Switch Adjustment Procedure in the maintenance section
Motor overloads frequently	Oil on new auger loads motor excessively when feed is carried for first time	Polish auger by running 50 lb (20 kg) increments of feed out to pans
	Inadequate power reaching motors	Check line voltage at the motors Check starting current draw at motors Wiring of adequate size is essential to feeder operation
	Object caught in the auger; motor runs, stalls, then auger spins in reverse	Check hopper boot, control unit and pan outlet holes for foreign objects Remove obstruction
Auger runs erratically	Frozen or cracked bearing at boot anchor	Replace bearing Slowly ease auger back into tube Be careful not to damage the bearing when reinserting the auger
	Insufficient stretch in auger	Shorten the auger
	Obstruction in the auger	Remove obstruction
Auger tube or boot wears out rapidly (Noisy feeder operation)	Auger is bent or kinked	Repair or replace damaged auger
	End of auger is riding up on anchor weldment	Auger must not be positioned over weld on anchor Check for bent or damaged auger
Oil leaking out of seals on power unit	Gearhead vent plug not installed	Replace plastic shipping plug with vent plug
	Defective gear head seal	Replace seal
Not enough feed supplied to the feeder pans	Insufficient time programmed on the time clock	Add more operating time to feeding period
	Feeder line control unit switch out of adjustment	Adjust switch according to the Switch Adjustment Procedure in the maintenance section
Brood openings will not stay in sync	Loose pivot bracket	Tighten the pivot bracket
Actuator will not move cones	Loose setscrew in pivot pin	Tighten setscrew
One pan will not operate	Loose or missing Pivot bracket	Tighten loose parts
Control pan does not function	Check operation of switch, check time delay check time delay selector	clean off any buildup make sure time delay is working select position 0 for control

# Wiring Diagrams

## End Control Internal Wiring

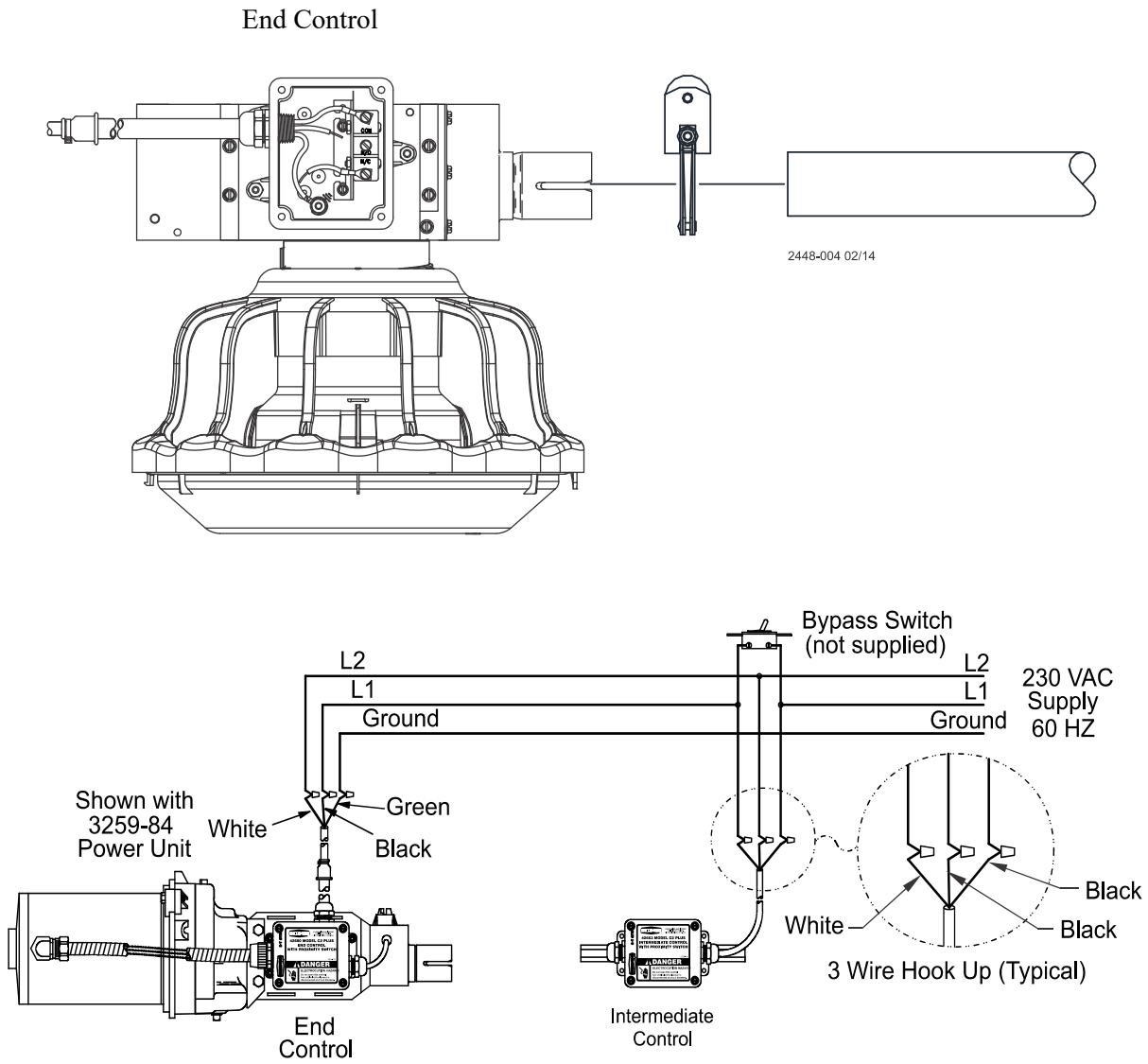
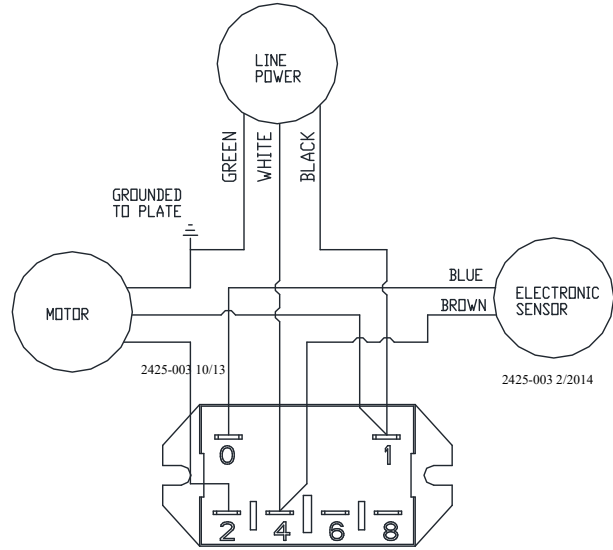
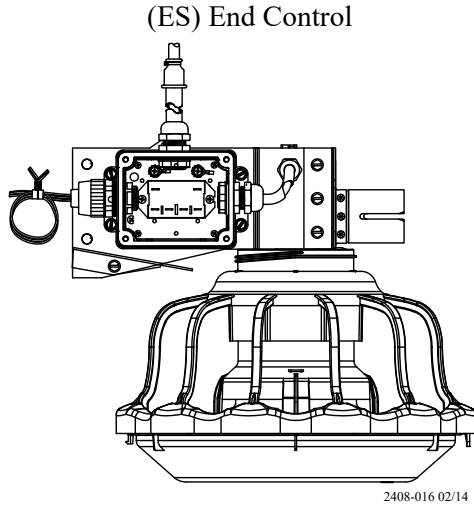
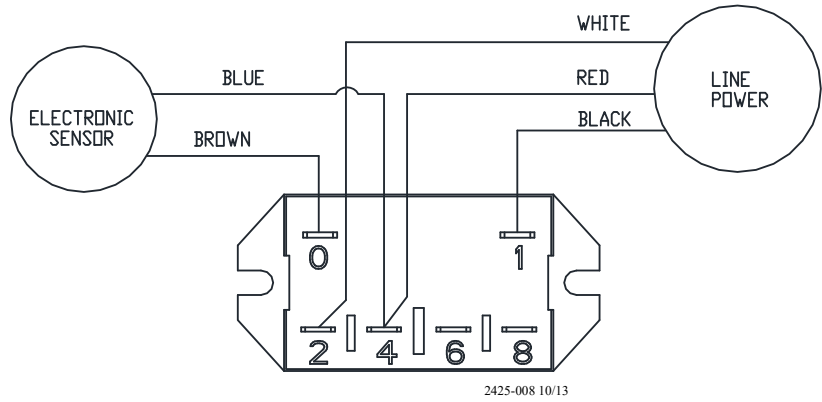
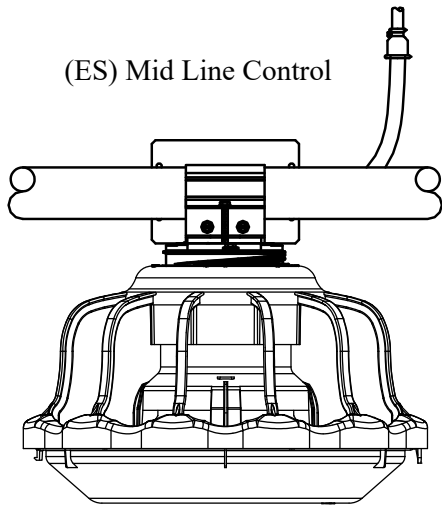

Figure 53. End Control Internal Wiring

### End Control With Electronic Sensor Wiring



### Mid Line Control With Electronic Sensor Wiring



# Electronic Sensor Three Phase(Ø) Wiring

FROM DISCONNECT OR  
CONTROL DISCONNECT  
220/380 VOLTS 50 HZ.  
THREE PHASE

PHASE  
PHASE  
PHASE  
NEUTRAL

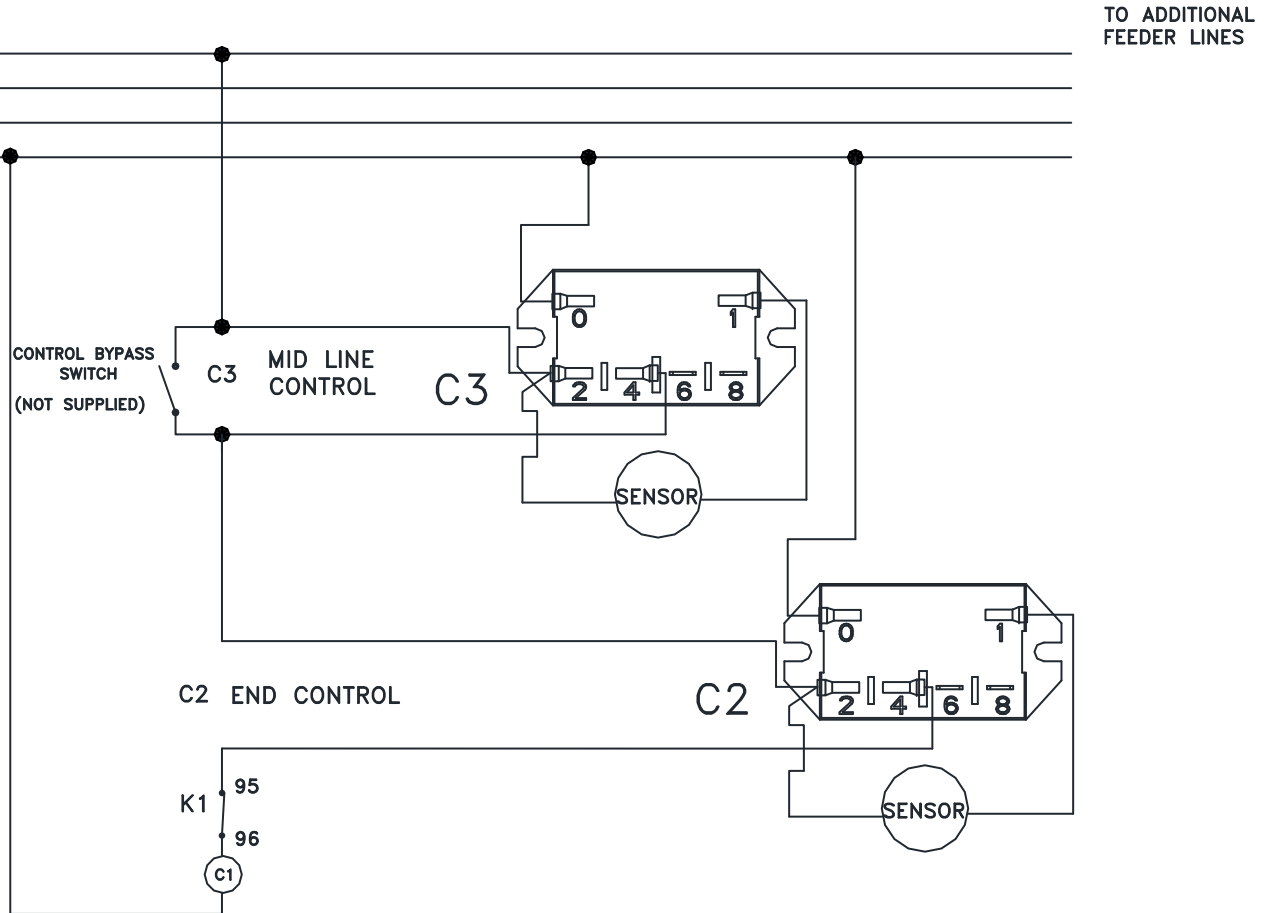
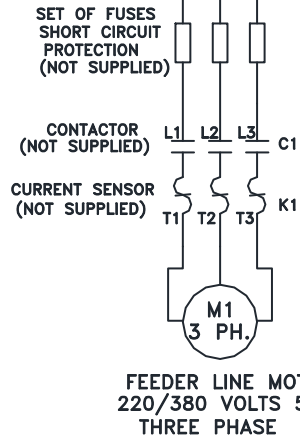

2425-002 10/13

# Parts Listing

## 150# Hopper Kit and Switch (49268)

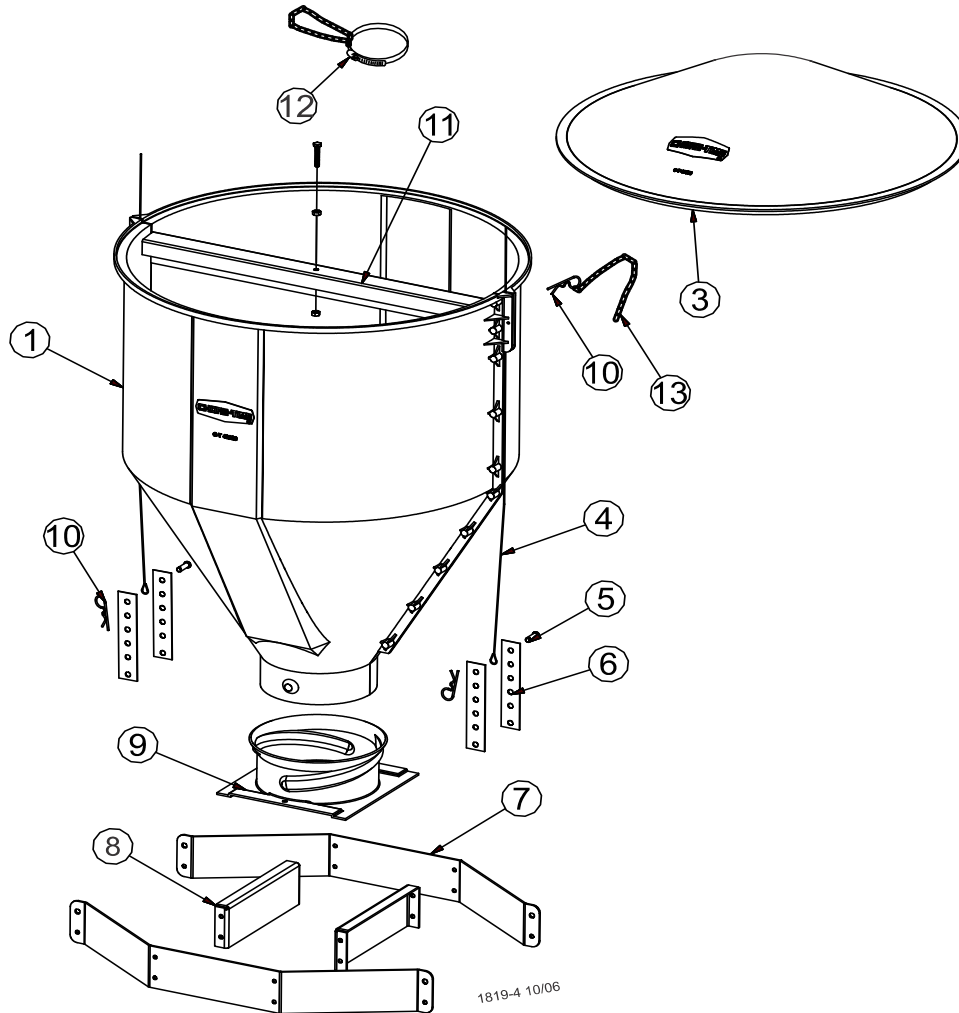

		Without Cover	With Cover
<b>Item</b>	<b>Description</b>	<b>48926</b>	<b>49267</b>
1	Hopper Half	49028	49028
2	--	--	--
3	Cover	--	48675
4	Cable Assembly	2809-3	2809-3
5	Clevis Pin	2797-1	2797-1
6	Adjustment Bracket	2706	2706
7	Suspension Angle	48679	48679
8	Suspension Brace	48680	48680
9	Twist Lock Collar	49041	49041
10	Hairpin	2664	2664
11	Brace	49029	49029
12	Tube Support Assembly	14367	14367
*13	Chain	2128	2128
<b>*Item must be ordered in either 100 ft or 250 ft quantities, 2128-100 is 100 ft and 2128-250 is 250 ft.</b>			

## Hopper Mount Bracket (Optional)

### Part Number 49358-Hopper Suspension Kit

Note: This Kit is used with steel hopper suspensions.

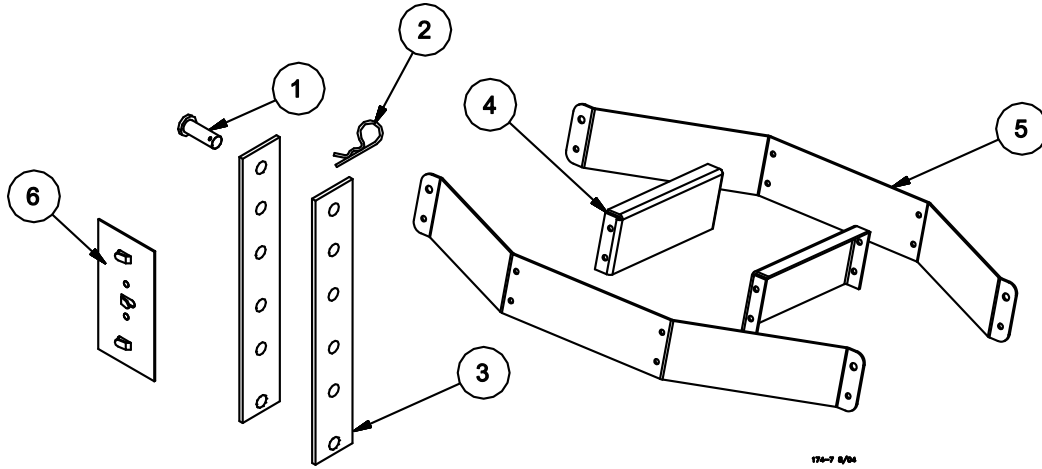

Item	Description	Part No. Single Boot Kit	Part No. Twin Boot Kit
1	Clevis Pin, 5/16" x 1"	2797-1	2797-1
2	Adjustment Bracket	2706	2706
3	Hair Pin	2664	2664
4	Suspension Brace	48680	48680
5	Suspension Angle	48679	48679
6	Cable Guide	34573	34573

## Single Boot Components Part No. 6822

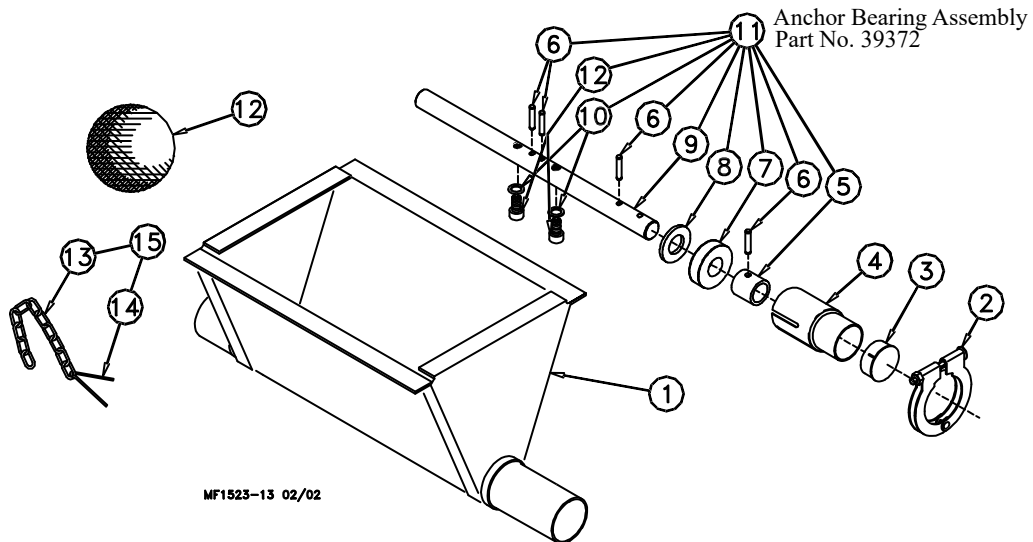

Item	Description	Part No.
1	Boot Weldment	3760
2	Tube Clamp	24063
3	Cap	29373
4	Outlet Tube	4556
5	Sleeve	5648
6	3/16 x 1" Pin	2960-1
7	Bearing	2689
8	Washer	2955-14

Item	Description	Part No.
9	Anchor	38540
10	Setscrew	47867
11	Anchor and Bearing Ass'y	39372
12	Cannonball	3531
13	Latch Pin Ass'y	2683
--	Danger Decal	2527-9



### Twin Boot Components Part No. 6824

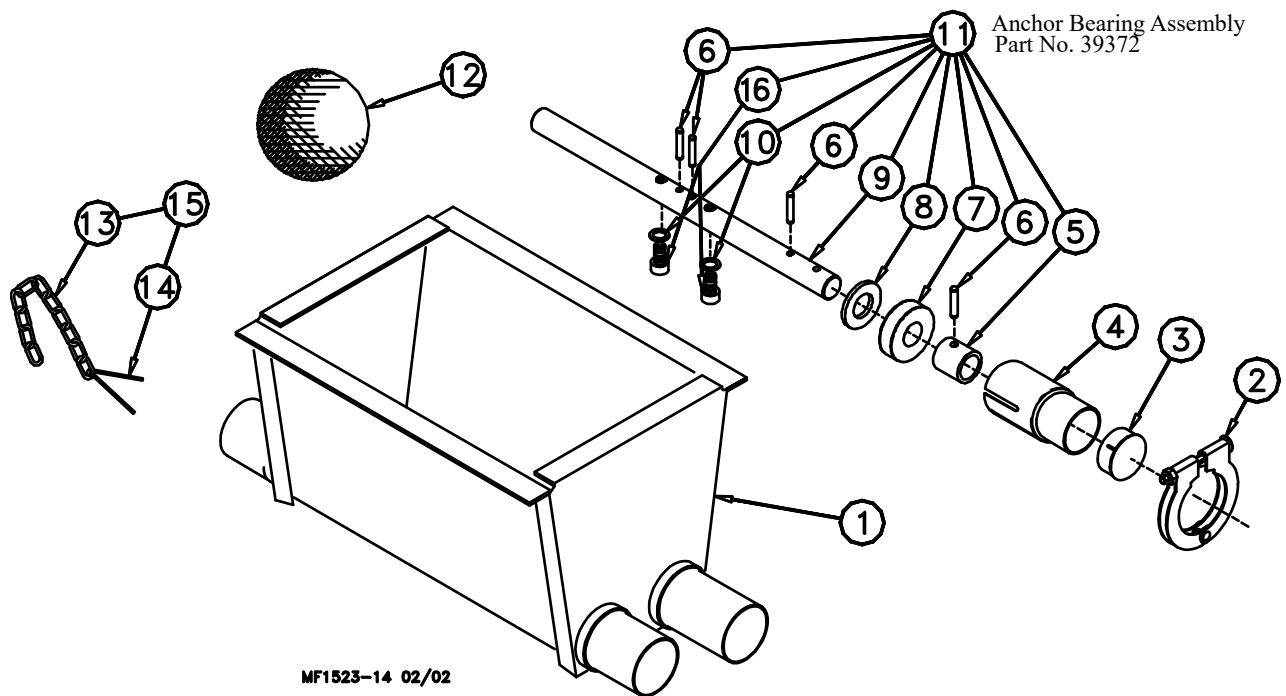

Item	Description	Part No.
1	Boot Weldment	3932
2	Tube Clamp	24063
3	Cap	29373
4	Outlet Tube	4556
5	Sleeve	5648
6	3/16 x 1" Pin	2960-1
7	Bearing	2689
8	Washer	2955-14
9	Anchor	38540

Item	Description	Part No.
10	Setscrew	47867
11	Anchor and Bearing Ass'y	39372
12	Cannonball	3531
13	Latch Pin Ass'y	2683
--*	Jumper Wire Kit	5360
--	Danger Decal	2527-9

\*The Jumper Wire Kit includes an insulated piece of High-Voltage Wire (part no. 28994) and (2) cable clamps.

### Feeder Line Components

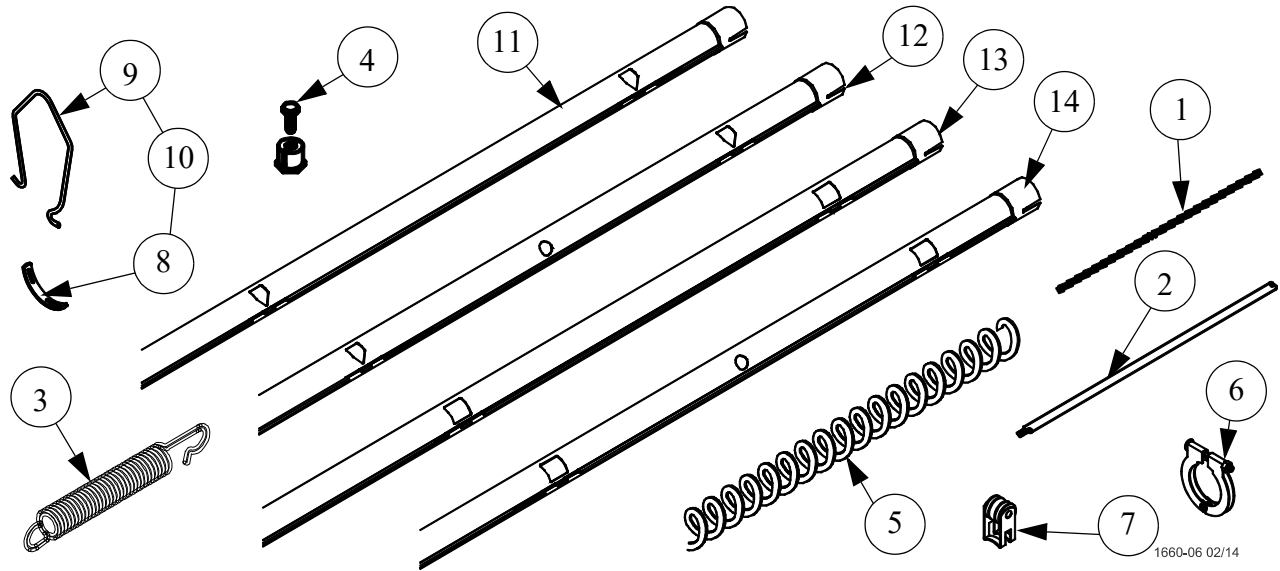

1860-06 02/14

Item	Description	Part No.
1	1/16" Cable	1922
2	Charger Wire (165') Charger Wire (330')	28994-165 28994-330
3	Spring	7551
4	1/16" Cable Clamp	1826
5*	Auger	6820-0
6	Tube Clamp	24063
7	Anti-Roost Bracket	24060
8	Hanger Bracket	50607
9	Hanger Strap	50606
10	Hanger Kit	51763
11	Standard Feeder Tube-1 3/4" Roll Form - 9', 4 Hole Tube - 10', 3 Hole Tube - 10', 4 Hole Tube - 12', 3 Hole Tube - 12', 4 Hole Tube - 12', 5 Hole Tube	6854-1 6854-5 6854-4 6854-8 6854-7 6854-6
12	Standard Feeder Tube-1 3/4" with Chick Holes (EZ. Holes) - 9', 4 Hole, 4 EZ. Holes - 10', 4 Hole, 4 EZ. Holes - 12', 4 Hole, 4 EZ. Holes - 12', 5 Hole, 5 EZ. Holes - 10', 3 Hole, 3 EZ. Holes - 9', 4 Hole, 2 EZ. Holes - 10', 4 Hole, 2 EZ. Holes - 12', 4 Hole, 2 EZ. Holes	6854-15 6854-16 6854-17 6854-18 6854-19 6854-20 6854-21 6854-22
13	Control Feeder Tube-1 3/4" Roll Form - 9', 4 Hole Tube - 10', 4 Hole Tube - 10', 3 Hole Tube - 12', 3 Hole Tube - 12', 4 Hole Tube - 12', 5 Hole Tube	43006-1 43006-4 43006-5 43006-8 43006-7 43006-6
14	Control Feeder Tube-1 3/4" with Chick Holes (EZ. Holes) - 9', 4 Hole, 4 EZ. Holes - 10', 4 Hole, 4 EZ. Holes - 12', 4 Hole, 4 EZ. Holes - 12', 5 Hole, 5 EZ. Holes	43006-15 43006-16 43006-17 43006-18
*Round up to the nearest 10'. Auger lengths from 50' to 500'. Example: 6820-200 = 200' roll of 6820 Auger.		

### Power Unit Assemblies

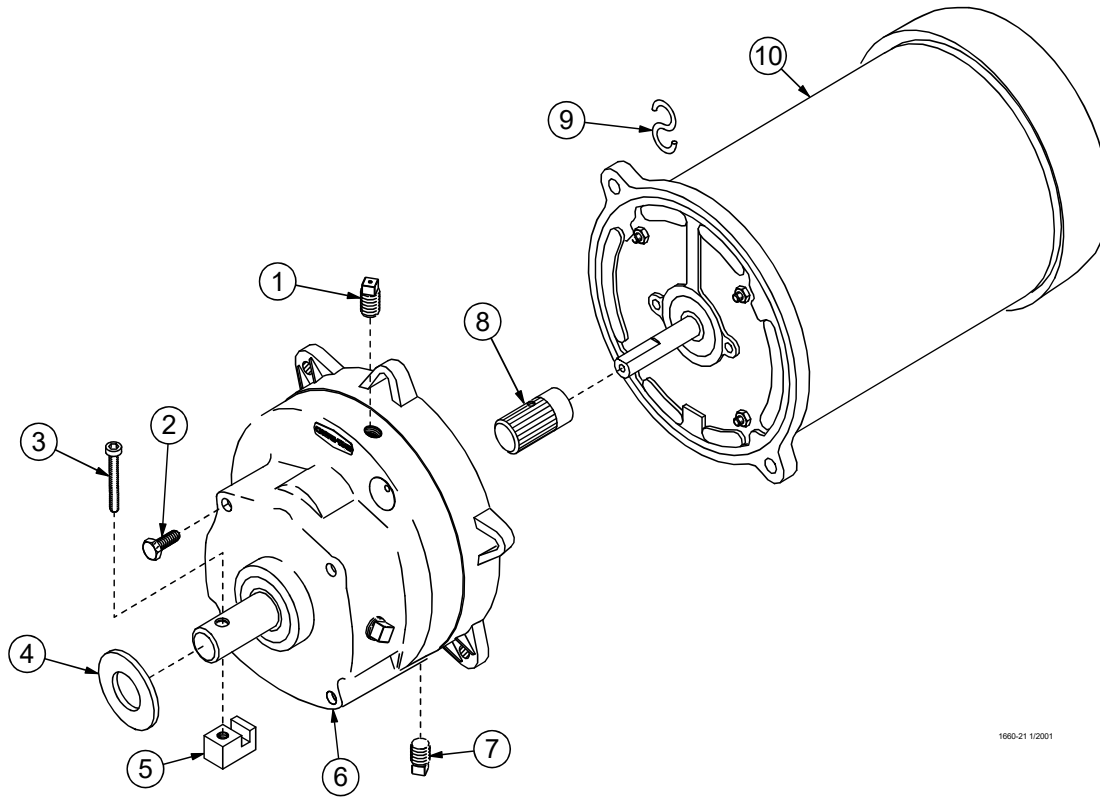

1660-21 1/2001

Item	Description	3259-84 Part No.	3259-85 Part No.	3259-98 Part No.	3259-100 Part No.	3259-128 Part No.
1	Vent Plug	3523	3523	3523	3523	3523
2	5/16-18x5/8 Hex Hd Screw	4412-1	4412-1	4412-1	4412-1	4412-1
3	1/4-20x1-1/2 Socket Hd Screw	5083-8	5083-8	5083-8	5083-8	5083-8
4	Flat Washer	1484	1484	1484	1484	1418
5	Driver Block	4642	4642	4642	4642	4642
6	Gearhead	3261-5	3261-5	3261-11	3261-11	3261-5
7	Pipe Plug (magnetic)	30160	30160	30160	30160	30160
8	Pinion Assembly	5046	5046	5046	5046	5046
9	"S" Hook	2805	2805	2805	2805	2805
10	Motor	4229	5703	5977	28031	24624
--	Cord Assembly	----	----	28028	----	----
--	Connector (90 Degree)	----	----	4228	----	----

### Power Unit Assembly Part Numbers:

Part No.	HP	RPM	Phase	Hz	Voltage
3259-84	1/3 HP	348 RPM	Single Phase	60 Hz	230
3259-85	1/2 HP	348 RPM	Single Phase	60 Hz	230
3259-98	1/2 HP	348 RPM	Single Phase	50 Hz	230
3259-100	1/2 HP	348 RPM	Three Phase	50 Hz	220/380
3259-128	1/2 HP	348 RPM	Three Phase	60 Hz	230

# Floor Flood Revolution® (FFR) End Controls

12 Spoke Mid-Line Control P/N 53965 and 8 Spoke Mid-Line Control P/N 53966

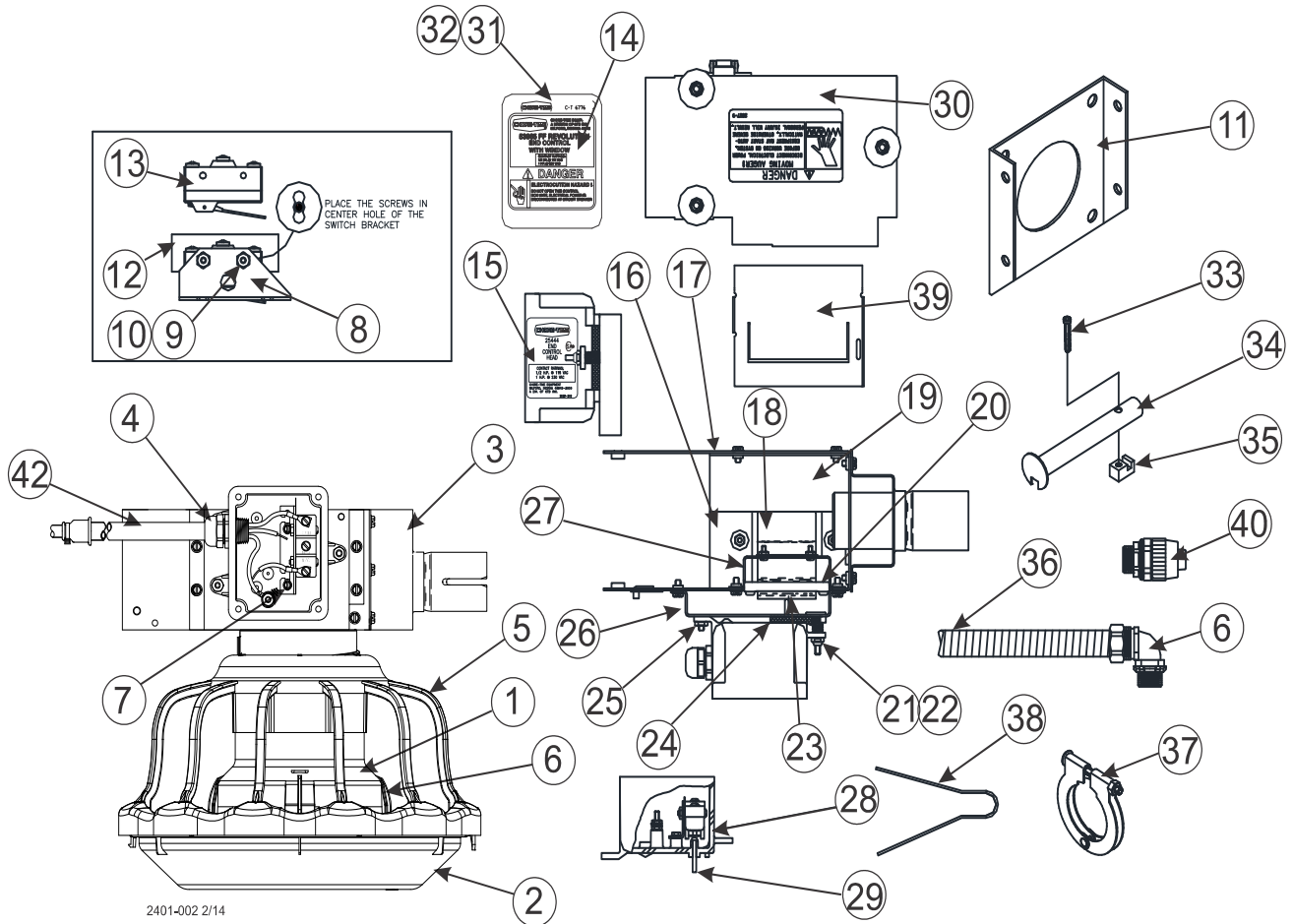

2401-002 2/14

Item	Description	53965	53965
		FF Revolution 12 Feeder End Control	FF Revolution 8 Feeder End Control
1	Cone (Packed)	53969	53969
2	Feeder Pan	46840	46840
3	Support Brkt.	24683	24683
4	1/2" Water Tight	24685	24685
5	12 Spoke Revolution Grill	--	46834
	8 Spoke Revolution Grill	43837	--
6	90 Deg. Metal Conduit Conn.	23810	23810
7	#6X 3/8" Hx Whd Screw	46011	46011
8	Switch Bracket	46122	46122
9	#6-32 X 7/8" Phd Screw	1921	1920
10	#6-32 Hx Nut	771	771
11	Anchor	4188	4188
12	Insulator Switch	1907-5	1907-5
13	Actuator Switch	46091	46091
14	Control Decal	2529-1092	2529-1093
15	Control Head Decal	2529-249	2529-249
16	Switch Bracket	40749	40749
17	Control Body	14434	14434
18	Mylar Assembly	25318	25318
19	Deflector Panel	41363	41363
20	Padded Retainer	25045	25045
21	#10-32 Lock Nut	6963	6963
22	Spring	6972	6972
23	Paddle	46123	46123
24	Gasket	6968-1	6968-1
25	#10 Lock Nut	34019	34019
26	Switchbox Mount	25084	25084
27	Stop Panel	25433	25433
28	Switch Box	24702	24702
29	1/8" x 1.00 Rivet	8757	8757
30	Top Cover	24682	24683
31	Switchbox Cover	6776	6776
32	Twin Helix Screw	28075	28075
33	#255-20 x 1.5 Screw	5083-8	5083-8
34	Drive Tube Weldment	44794	44794
35	Drive Block	4642	4642
36	1/2" Flex Conduit	26982-1	26982-1
37	1.75 Dia. Clamp	24063	24063
38	Anti-Roost	2798	2798
39	Bottom Cover	14432	14432
40	Straight Conduit Connector	26980	26980

# Floor Flood Revolution® (FFR) Mechanical Mid-Line Control

## 12 Spoke Mid-Line Control P/N 53967 and 8 Spoke Mid-Line Control P/N 53968

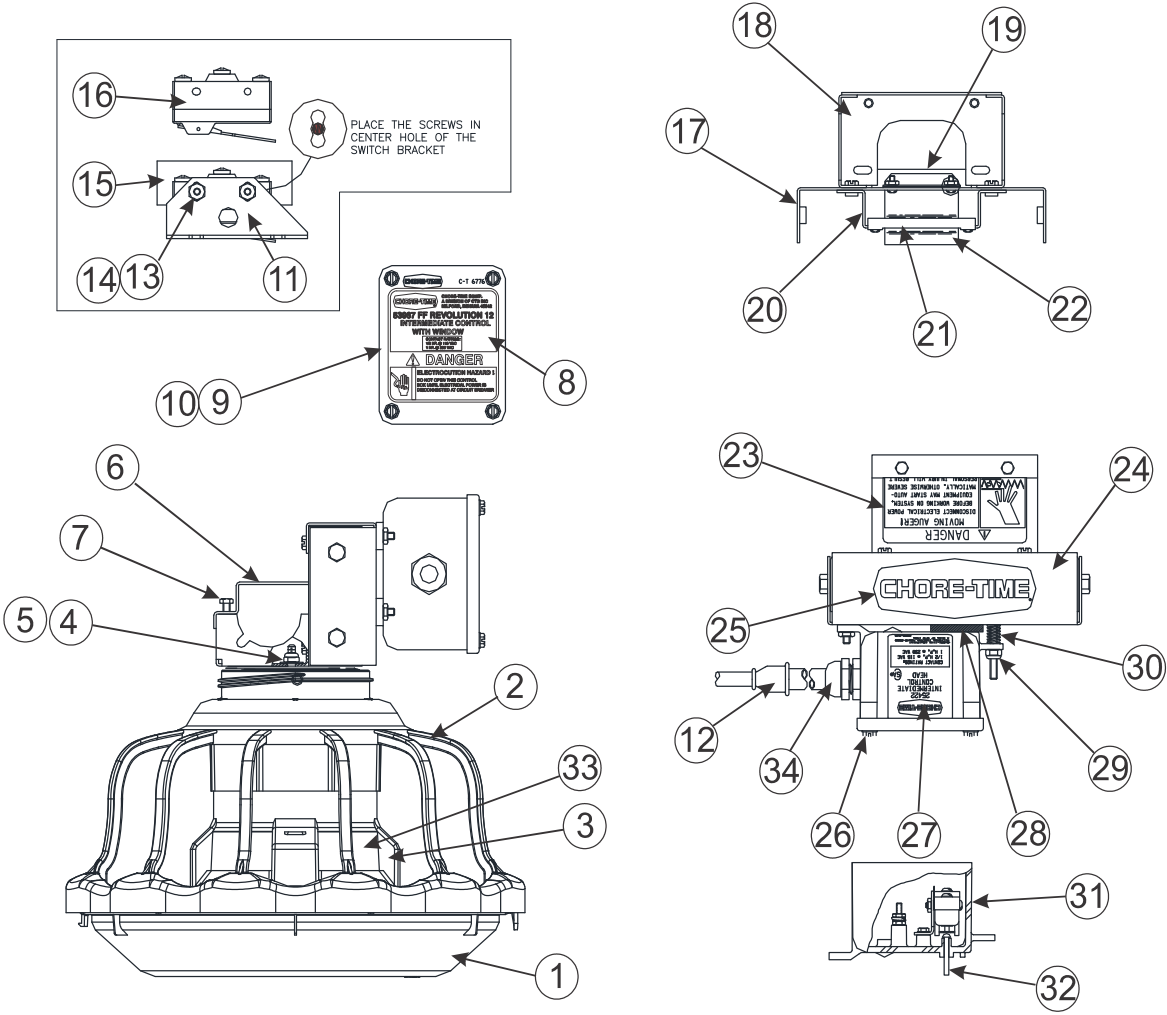

Item	Part No.	Description
1	46840	Feeder Pan
2	46837 46834	Revolution Grill 12 Spoke Revolution Grill 8 Spoke
3	53969	Cone (Packed)
4	1667	Lock Washer
5	34019	10-24 Lock Nut
6	14756	Tube Retainer
7	4416-4	#10-24 X 1.75 HXHD Screw
8	2529-1094 2529-1095	Control Decal (12 Spoke) Control Decal (8 Spoke)
9	6776	Switch Box Cover
10	6777	Gasket
11	46122	Switch Bracket
12	4999-49	Cord Assembly
13	1921	#6-32 X 7/8" Screw
14	771	#6-32 Nut
15	1907-5	Insulation
16	46091	Actuator Switch
17	25046	Front Panel

Item	Part No.	Description
18	41364	Tube Support
19	25318	Mylar Assembly
20	25048	Pivot Bracket
21	25045	Paddle Retainer
22	46123	Paddle
23	2527-9	Danger Decal
24	25047	Back Cover
25	2525-2	Chore-Time Decal
26	28075	Twin Helix Screw
27	2529-248	Control Head Decal
28	6968-1	Gasket
29	6963	10-32 Lock Nut
30	6972	Spring
31	34842	Machined Switch Box
32	8757	1/8" Rivet
33	53963	Inner Cone
34	24685	1/2" Watertight Conn.

# Floor Flood Revolution® (FFR) Mid-Line Control with Electronic Sensor

## 12 Spoke Control P/N 55491 and 8 Spoke Control P/N 55490

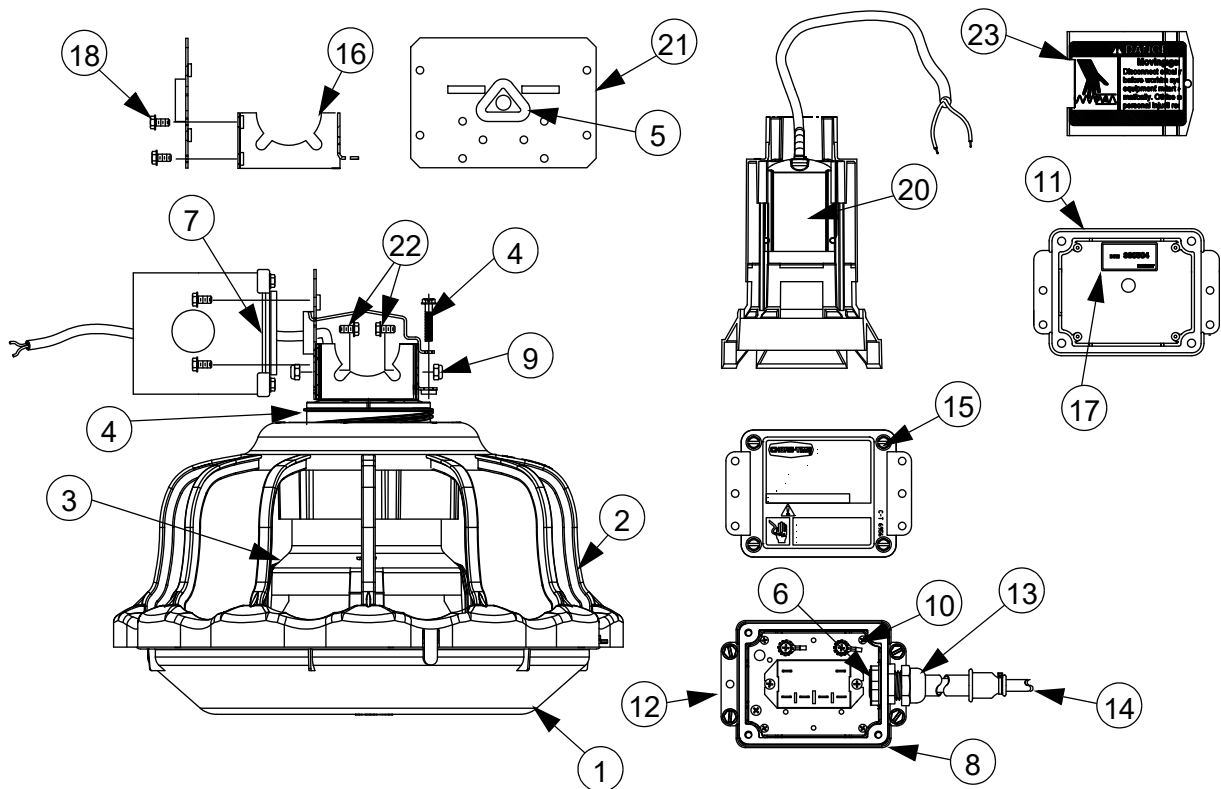

Item	Description	55491 FF Revolution 12 Feeder End Control w/Electronic Sensor	54490 FF Revolution 8 Feeder End Control w/Electronic Sensor
1	Feeder Pan	46840	46840
2	Revolution Grill 12 Spoke	46837	--
	Revolution Grill 8 Spoke	--	46834
3	Cone (Packed)	53969	53969
4	#10 -24 x 1.25 Screw	4416-9	4416-9
5	Gasket	6968-1	6968-1
6	.50 Nylon Lock Nut	43662	43662
7	Switch Box Gasket	6777	6777
8	(Mach) General Purp. Box	42627-1	42627-1
9	10-24 Lock Nut	34019	34019
10	4-24 x .375 Ph. Pan Hd. Screw	35493	35493
11	Machined Mounting Cover	48503	48503
12	Mounting Terminal Box Cover	6956	6956
13	1/2" Liquid Tight Connector	24685	24685
14	Cord Assembly	4999-103	4999-103
15	#10 x .5 Hx. WH Screw	28075	28075
16	Mid-Line Control Body	48087	48087
17	D.O.M. Decal	2526-377	2526-377
18	#10-24 Patch Lock Screw	4416-7	4416-7
19	Control Lock Arm	48525	48525
20	Electronic Sensor	54670	54670
21	Mid-Line Control Rear Panel	48088	48088
22	#10-24 x 1.25 Screw	25124	25124
23	Mid-Line Control Cover	48089	48089
24	Mid-Line Control Decal	2529-1146	2529-1145

# Floor Flood Revolution® (FFR) End Control with Electronic Sensor

12 Spoke Mid-Line Control P/N 55489 and 8 Spoke Mid-Line Control P/N 55488

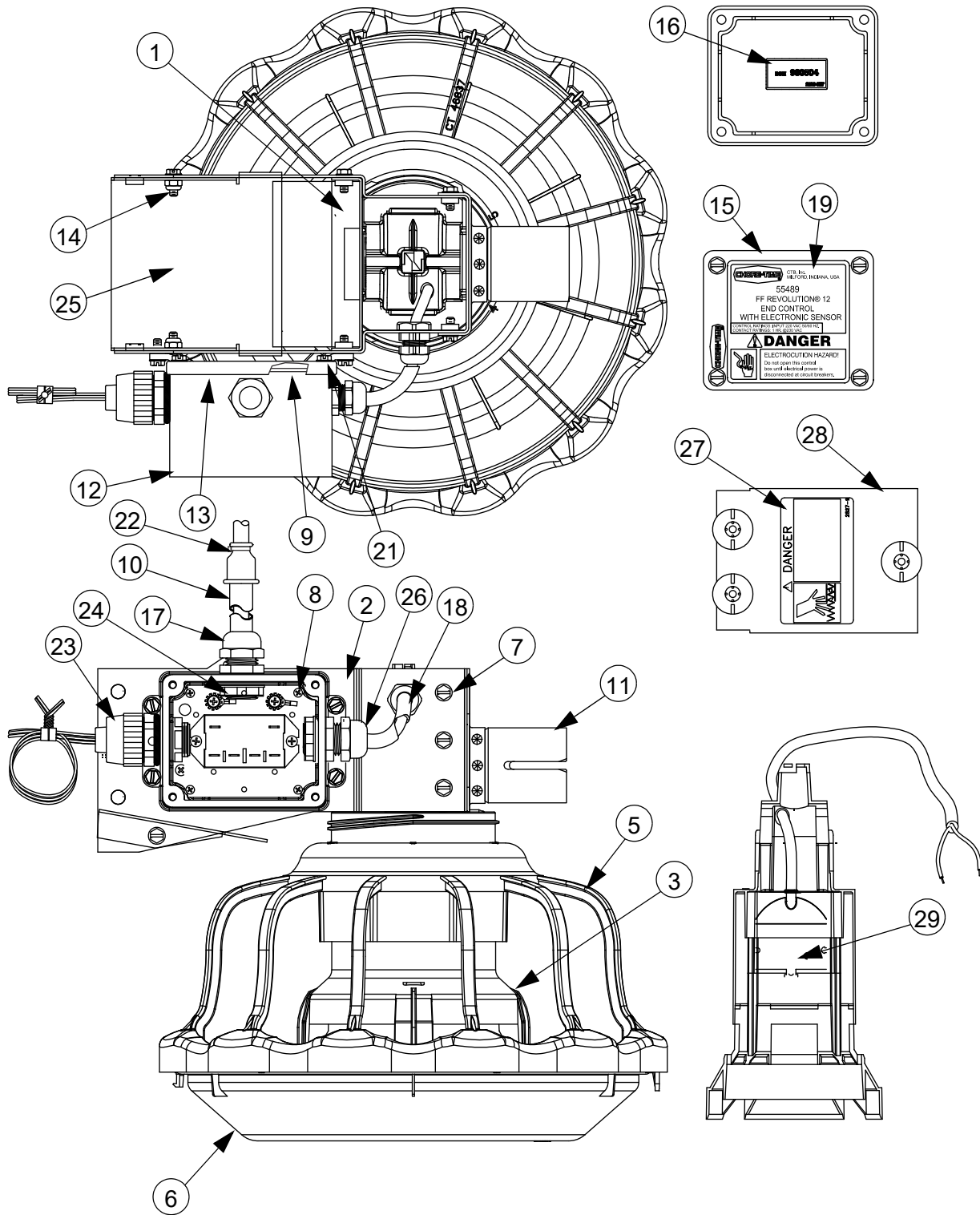



Item	Description	55489 FF Revolution 12 Feeder End Control w/Electronic Sensor	55488 FF Revolution 8 Feeder End Control w/Electronic Sensor
1	Support Bracket	48081	48081
2	Feeder Control Body	48080	48080
3	Packed Cone	53969	53969
4	Liquid Tight Connector	13477	13477
5	12 Spoke Revolution Grill	46837	--
	8 Spoke Revolution Grill	--	46834
6	Feeder Pan	46840	46840
7	#10-24 Screw	4416-7	4416-7
8	4-24 x .375 SS Phil PH Screw	35493	35493
9	Switch Box Gasket	6777	6777
10	Cord Assembly	4999-100	4999-100
11	Tube Weldment	48082	48082
12	General Purpose (mach.) Terminal Box	42627-12	42627-12
13	Mounting Terminal Box Cover	6956	6956
14	10-24 Hx Nylon Nut	34019	34019
15	White Box Cover	6776	6776
16	D.O.M. Decal	2526-377	2526-377
17	1/2" Liquid Tight Connector	24685	24685
18	4" Black Tube	14454-4	14454-4
19	End Control Decal	2529-1144	2529-1143
20	Control Lock Arm	57525	57525
21	#10 x .5 Hx WH Screw	28075	28075
22	Cable Tie	6635	6635
23	1/2-14 Str. Liquid Tight Fitting	26980	26980
24	1/2" Conduit Lock Nut	43662	43662
25	End Control Bottom Cover	48086	48086
26	1/2" Liquid Tight Connector	23779	23779
27	Rotating Auger Danger Decal	2527-9	2527-9
28	Top Cover with Insulators	48491	48491
29	Pan Assembly Sensor	52966	52966

### Power Winch (Part No. 47687)

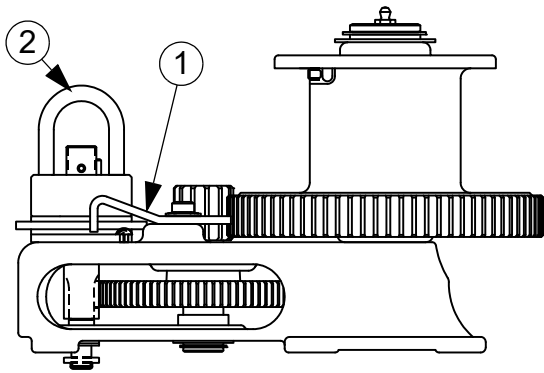

Item	Qty.	Description	Part No.
1	1	Pawl	47687-5
2	1	Input Shaft Assembly	47687-1

### Miscellaneous Suspension Components

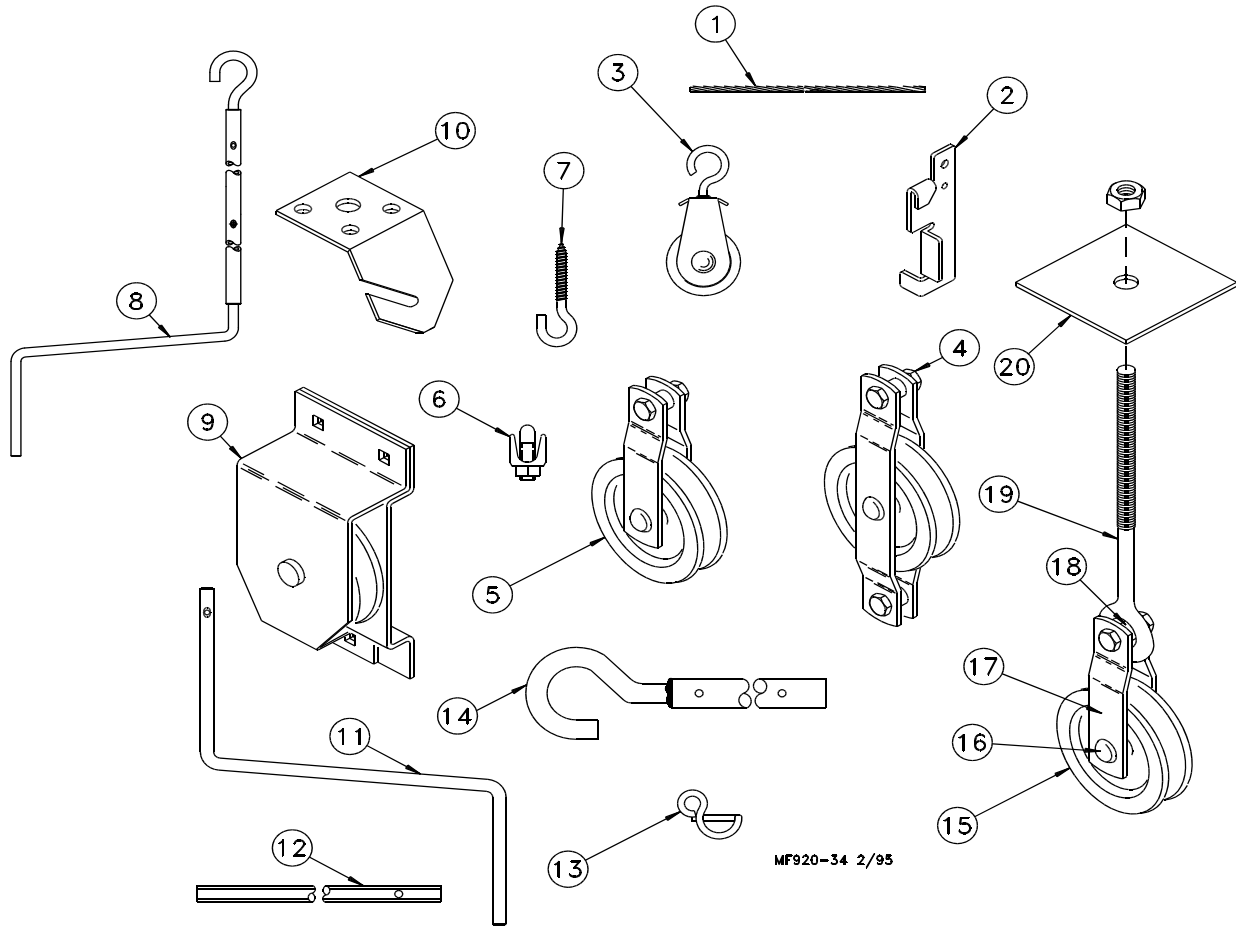

Item	Description	Part No.
1	3/32" Cable 3/16" Cable 1/8" Cable	4973 1213 27975
2	Cable Lock	14337
3	Pulley with Swivel	3004
4	Double Eye Pulley	2501
5	Pulley	2500
6	3/16" Cable Clamp 1/8" Cable Clamp	732 14898
7	Standard Screw Hook Large Screw Hook	1214 2041

Item	Description	Part No.
8	Pulley Assembly	28429
9	Suspension Bracket Suspension Bracket with Screws	28550 28832
10	Handle Shank	3148
11	Drill Adapter Shaft	3151
12	Winch Handle Pin	3761
13	Winch Drive Tube (4') Winch Drive Tube (8') Winch Drive Tube (2')	2884-1 2884-2 2884-4
14	Telescoping drive handle 5 to 8 foot	47638

Item 10 and Item 12 may be ordered as a kit under part no. 2885.

Item 11 and Item 12 may be ordered as a kit under part no. 2886.

### Feeder Components

**53367**  
FF Revolution® Feeder  
12 Spoke w/Windows

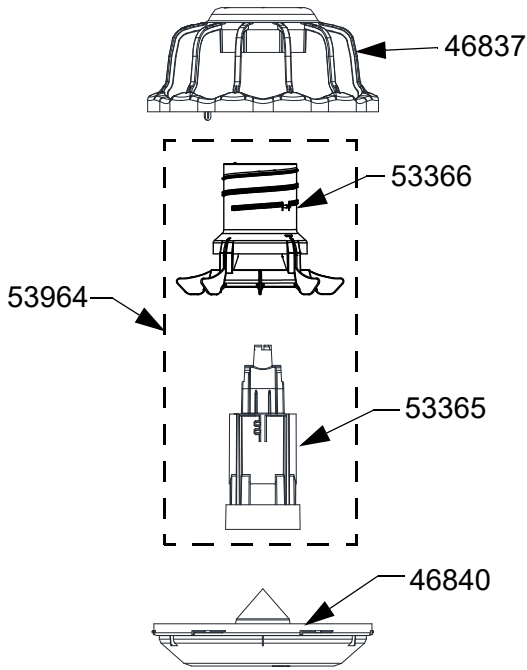

**47677**  
FF Revolution® Feeder  
12 Spoke Non-Window

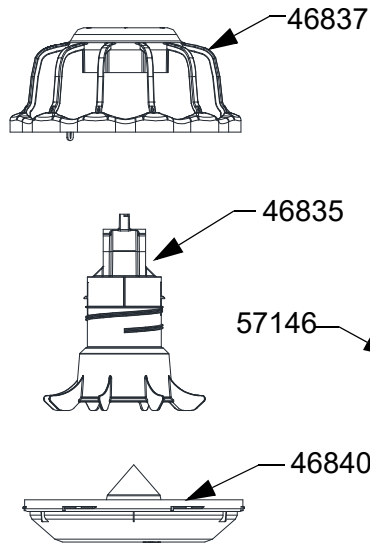

**57144**  
FF Revolution® Feeder  
12 Spoke w/Two Piece Top

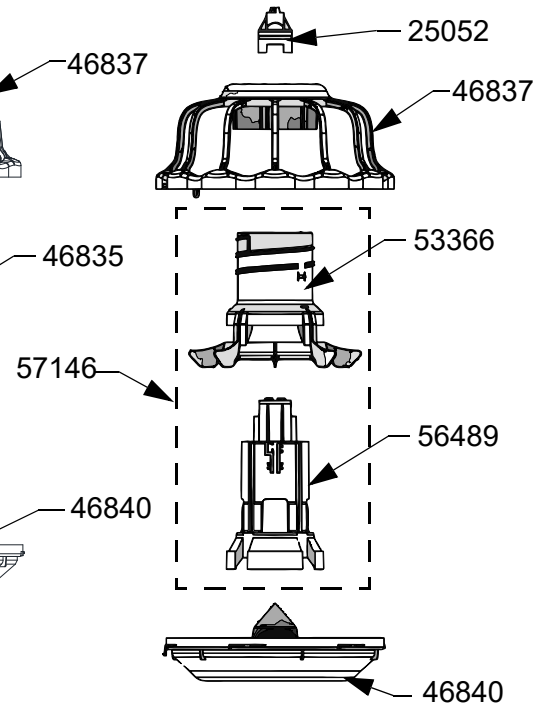

**53368**  
FF Revolution® Feeder  
8 Spoke w/Windows

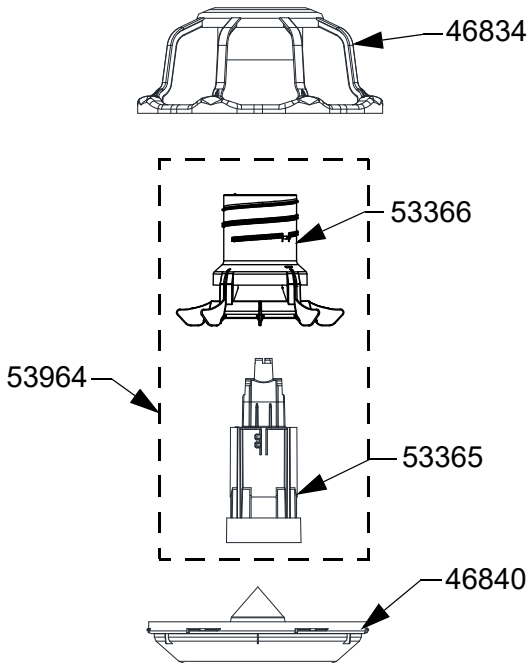

**47675**  
FF Revolution® Feeder  
8 Spoke Non-Window

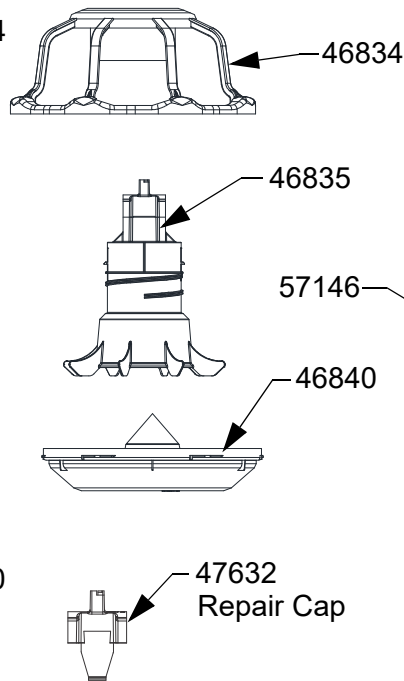

**57145**  
FF Revolution® Feeder  
8 Spoke w/Two Piece Top

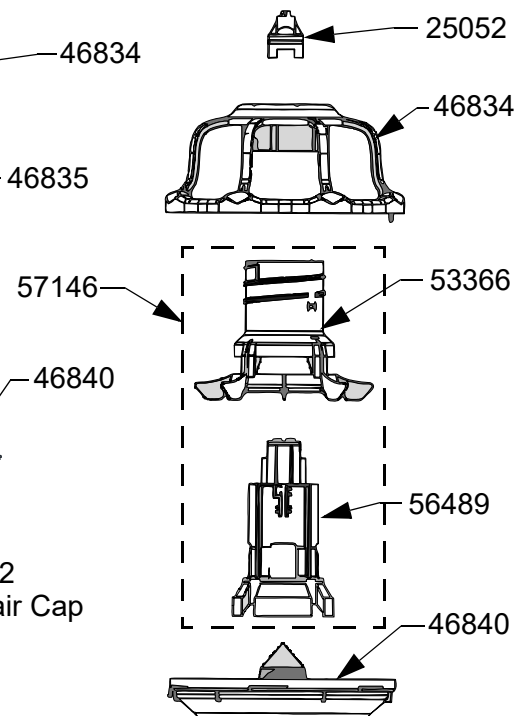

**This page left blank intentionally.....**

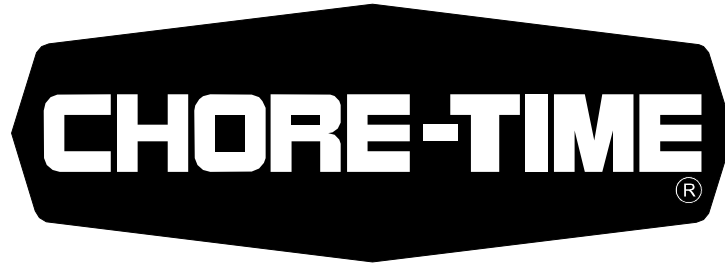

**MADE TO WORK.**

**BUILT TO LAST.®**

### **Revisions to this Manual**

<b>Page No.</b>	<b>Description of Change</b>	<b>ECO</b>
50	Was 2883 Winch	35577
Various	Updated Graphics (darker)	

**Contact your nearby Chore-Time distributor or representative for additional parts and information.**

CTB, Inc.  
PO Box 2000  
Milford, Indiana 46542-2000 USA  
Phone (574) 658-4101 Fax (877) 730-8825  
Email: [choretime@choretime.com](mailto:choretime@choretime.com)  
Internet: [www.choretime.com](http://www.choretime.com)