

CHORE-TIME[®]

REVOLUTION[®] 8 Rooster Feeder Variable Brood Feeding System

Installation and Operators Manual

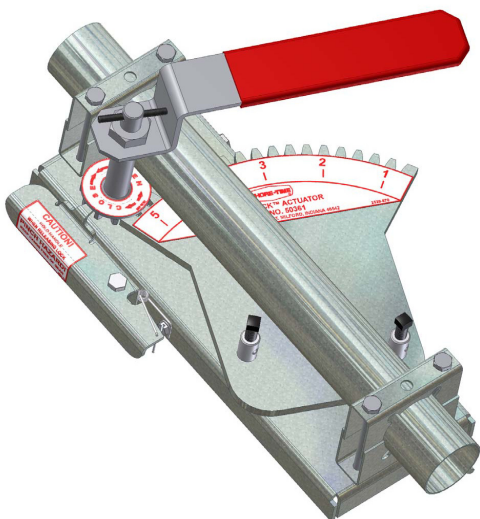

ACCU-CLICK[™] Manual Actuator



Installation and Operators Manual

Installation and Operators Manual

Chore-Time Warranty

CTB, Inc., (“Chore-Time”), warrants each new CHORE-TIME® product manufactured by it to be free from defects in material or workmanship for one-year from and after the date of initial installation by or for the original purchaser. If such a defect is found by Chore-Time to exist within the one-year period, Chore-Time will, at its option, (a) repair or replace such product free of charge, F.O.B. the factory of manufacture, or (b) refund to the original purchaser the original purchase price, in lieu of such repair or replacement. Labor costs associated with the replacement or repair of the product are not covered by the Manufacturer.

Additional extended warranties for the equipment and/or systems listed below are provided to the original purchaser as follows (for all other CHORE-TIME® products purchased, the one-year warranty period shall apply):

1. TURBO® and RLX™ fans, less motors - 3 years
2. TURBO® fan fiberglass housings, polyethylene cones, and cast aluminum blades - for the life of the product
3. TURBO® fan motors and bearings - 2 years
4. TURBO® fan components (including plastic shutters) - 3 years
5. Poultry feeder pans that become unusable within five years from the date of installation - Warranty prorated after three years usage
6. Rotating centerless augers, excluding applications involving high moisture feed stuffs (exceeding 18%), for ten years from the date of installation. Note: MULTIFLO® and applications involving high moisture feed stuffs are subject to a one-year warranty
7. Chore-Time manufactured roll-formed steel auger tubes for ten years from the date of installation
8. ULTRAFLO® Breeder Feeding System auger and feed trough are warranted for a period of five years from the date of original installation against repeated breakage of the auger or wear-through of the feed trough caused solely by the auger
9. ULTRAPAN® Feeding System augers are warranted for a period of five years from the date of installation

CONDITIONS AND LIMITATIONS

1. The product must be installed by and operated in accordance with the instructions published by the Manufacturer or Warranty will be void.
2. Warranty is void if all components of the system are not original equipment supplied by the Manufacturer.
3. This product must be purchased from and installed by an authorized distributor or certified representative thereof or the Warranty will be void.
4. Malfunctions or failure resulting from misuse, abuse, negligence, alteration, accident, or lack of proper maintenance shall not be considered defects under the Warranty.
5. This Warranty applies only to systems for the care of poultry and livestock. Other applications in industry or commerce are not covered by this Warranty.

Chore-Time shall not be liable for any consequential or special damage which any purchaser may suffer or claim to suffer as a result of any defect in the product. "Consequential" or special damages" as used herein include, but are not limited to, lost or damaged products or goods, costs of transportation, lost sales, lost orders, lost income, increased overhead, labor and incidental costs and operational inefficiencies.

THIS WARRANTY CONSTITUTES THE MANUFACTURER'S ENTIRE AND SOLE WARRANTY AND THIS MANUFACTURER DISCLAIMS ANY AND ALL OTHER WARRANTIES, INCLUDING, BUT NOT LIMITED TO, EXPRESS AND IMPLIED WARRANTIES AS TO MERCHANTABILITY, FITNESS FOR PARTICULAR PURPOSES SOLD AND DESCRIPTION OR QUALITY OF THE PRODUCT FURNISHED HEREUNDER.

Chore-Time Distributors are not authorized to modify or extend the terms and conditions of this Warranty in any manner or to offer or grant any other warranties for Chore-Time products in addition to those terms expressly stated above.

An officer of CTB, Inc. must authorize any exceptions to this Warranty in writing. Chore-Time reserves the right to change models and specifications at any time without notice or obligation to improve previous models.

Effective: **July 2004**

Thank You

The employees of Chore-Time would like to thank your for your recent Chore-Time purchase. If a problem should arise, your Chore-Time distributor can supply the necessary information to help you.

***Chore-Time Poultry Feeder Pan Pro Rata Schedule**

Year from date of installation during which pan becomes unusable	Charge to be paid by the purchaser for replacement.
0 - 1 years	NO CHARGE
1 - 2 years	NO CHARGE
2 - 3 years	NO CHARGE
3 - 4 years	4/10 of then current list price
4 - 5 years	5/10 of then current list price

Contents

Topic	Page
Chore-Time Warranty	2
CONDITIONS AND LIMITATIONS	3
About This Manual	6
Safety Information	6
Safety Instructions	7
Follow Safety Instructions	7
Decal Descriptions	7
General	7
Information	7
Manufacturer's Recommendations: Birds per Pan	8
Planning the Suspension System	9
General Installation Information	10
Laying out the Suspension System	10
Installing the Suspension System	11
Power Lift Winch Installation	11
Installing the Main Winch Cable	12
Screw Hook Installation	13
Ceiling Hook Installation	14
Ceiling Hook Installation	14
Drop Installation	15
Hopper Assembly Procedure	16
Assembly	16
Suspend the Hopper	16
Feeder Pan Assembly (Window Cone System)	18
Installing the Pivot Clip	20
Feeder line planning (Window Cone System)	21
ACCU-CLICK™ Actuator	21
Feeder Line Assembly and Suspension (Window Cone System)	23
ACCU-CLICK™ Actuator Installation	23
Feeder Pan and Tube Assembly Process	23
Assemble and Suspend the Feeder Line	24
Anti-Swing Installation	27
Actuator Installation (Window Cone Systems)	28
Installing spring brackets:	28
Spring bracket installation for 9 foot 4 hole and 12 foot 5 hole tubes	28
Installing actuator wire:	30
Setting ACCU-CLICK™ Actuator	32
Feeder Pan Assembly (Indexing System)	33
Feeder Line Assembly & Suspension (Indexing System)	36
Feeder Pan and Tube Assembly Process	36
Assemble and Suspend the Feeder Line	36
Indexing the Feeder	38
Indexing Chart for Male Feeders	40

Contents - continued

Topic	Page
For Systems using 9' (2.7 m) Auger Tube and 348 RPM Power Units	40
For Systems using 10' (3 m) or 12' (3.6m) Auger Tube and 696 RPM Power Units	41
Anti-Swing Installation	42
End Control and Boot Assembly Installation	43
Auger Installation	44
Auger Brazing	47
Anti-Roost Installation	48
Electro-guard Operation	50
Feeder Management and Operation	51
Initial Start-up of the Feeding System	51
General Operation of the REVOLUTION® 8 Feeders	53
REVOLUTION® Rooster Feeder Operation Guide	53
End Control Pans	53
Maintenance	54
Floor Feeding System Maintenance	54
Gear Head Maintenance	54
SENSOR PLUS™ Sensor Switch Adjustment for Control Units	55
Feeder Line	55
Power Lift Winch Maintenance	56
Trouble Shooting the Floor Feeding System	57
Wiring Diagrams	58
Internal Wiring End Control	58
SENSOR PLUS™ Control Wiring Diagram	59
SENSOR PLUS™ Three Phase(Ø) Wiring	60
Parts Listing	61
150# Hopper Components	61
Single Boot Components Part No. 6822	62
Twin Boot Components Part No. 6824	63
Feeder Line Components	64
Power Unit Assemblies	65
Power Unit Assembly Part Numbers:	65
Sensor Plus End Control	66
Part No. 48509 REVOLUTION® 8 END CONTROL	66
50361 ACCU-CLICK™ Rooster Feeder System	68
47687 Power Winch	69
Indexing Gauge	69
Miscellaneous Suspension Components	70
Feeder Components	71

About This Manual

The intent of this manual is to help you in two ways. One is to follow step-by-step in the order of assembly of your product. The other way is for easy reference if you have questions in a particular area.

Important: Read **ALL** instructions carefully before starting construction.

Important: Pay particular attention to all **SAFETY** information.

- *Metric measurements are shown in millimeters and in brackets, unless otherwise specified. “ ” equals inches and “ ’ ” equals feet in English measurements.*

Examples:

1" [25.4]

4' [1 219]

- Optional equipment contains necessary instructions for assembly or operation.
- Very small numbers near an illustration (*i.e.*, 1257-48) are identification of the graphic, not a part number.

Note: The original, authoritative version of this manual is the English version produced by CTB, Inc. or any of its subsidiaries or divisions, (hereafter collectively referred to as “CTB”). Subsequent changes to any manual made by any third party have not been reviewed nor authenticated by CTB. Such changes may include, but are not limited to, translation into languages other than English, and additions to or deletions from the original content. CTB disclaims responsibility for any and all damages, injuries, warranty claims and/or any other claims associated with such changes, inasmuch as such changes result in content that is different from the authoritative CTB-published English version of the manual. For current product installation and operation information, please contact the customer service and/or technical service departments of the appropriate CTB subsidiary or division. Should you observe any questionable content in any manual, please notify CTB immediately in writing to: CTB Legal Department, P.O. Box 2000, Milford, IN 46542-2000 USA.

Safety Information

Caution, Warning and Danger Decals have been placed on the equipment to warn of potentially dangerous situations. Care should be taken to keep this information intact and easy to read at all times. Replace missing or damaged safety decals immediately.

Using the equipment for purposes other than specified in this manual may cause personal injury and/or damage to the equipment.

Safety–Alert Symbol



This is a safety–alert symbol. When you see this symbol on your equipment, be alert to the potential for personal injury. This equipment is designed to be installed and operated as safely as possible...however, hazards do exist.

Understanding Signal Words

Signal words are used in conjunction with the safety–alert symbol to identify the severity of the warning.



DANGER indicates an imminently hazardous situation which, if not avoided, **WILL** result in death or serious injury.



WARNING indicates a potentially hazardous situation which, if not avoided, **COULD** result in death or serious injury.



CAUTION indicates a hazardous situation which, if not avoided, **MAY** result in minor or moderate injury.

Safety Instructions

Follow Safety Instructions

Carefully read all safety messages in this manual and on your equipment safety signs. Follow recommended precautions and safe operating practices.

Keep safety signs in good condition. Replace missing or damaged safety signs.

Decal Descriptions

DANGER: Moving Auger

This decal is placed on the Panel Weldment.

Severe personal injury will result, if the electrical power is not disconnected, prior to servicing the equipment.

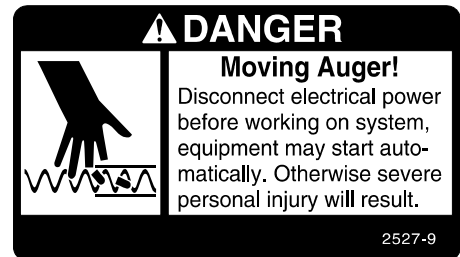

DANGER: Electrical Hazard

Disconnect electrical power before inspecting or servicing equipment unless maintenance instructions specifically state otherwise.

Ground all electrical equipment for safety.

All electrical wiring must be done by a qualified electrician in accordance with local and national electric codes.

Ground all non-current carrying metal parts to guard against electrical shock.

With the exception of motor overload protection, electrical disconnects and over current protection are not supplied with the equipment.

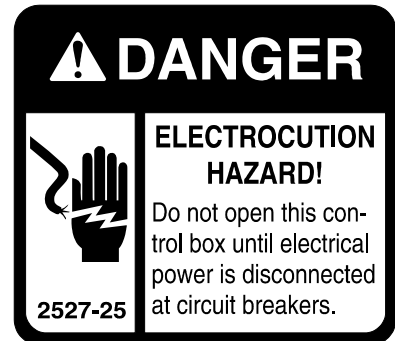

CAUTION:

Use caution when working with the Auger—springing Auger may cause personal injury.

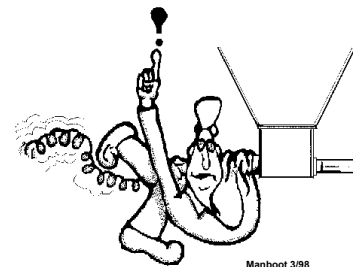

General

Information

The Chore-Time REVOLUTION® 8 Rooster Feeder Variable Brood Feeding System has been designed to feed poultry. Using this equipment for any other purpose or in a way not within the operating recommendations specified in this manual will void the warranty and may cause personal injury.

This manual is designed to provide comprehensive planning and installation information. The Table of Contents provides a convenient overview of the information in this manual.

Manufacturer's Recommendations: Birds per Pan

Type	Max weight and/or weeks of age	Feeders	Number of birds/pan
Broiler	4.5 lbs/2 kg.	Revolution 12, Models C2 Plus, C2 Plus S, C, H2, H2 Plus	60 - 90
Broiler	6 lbs/2.7 kg	Revolution 8 & 12, C2 Plus, C2 Plus S, G Plus, G Plus S, C, H2, H2 Plus	55 - 80
Broiler	7 lbs/3.1 kg	Revolution 8 & 12, C2 Plus, C2 Plus S, G Plus, G Plus S, C, H2, H2 Plus	55 - 75
Broiler	9 lbs/4.0 kg	Revolution 8, G Plus, G Plus S	45 - 65
Broiler Breeder Pullet – rearing	0 – 18 weeks	C2 Plus (Breeder), C2 Plus S (Breeder)	14 - 15
Broiler Breeder Pullet – rearing	0 – 18 weeks Hi-Yield	C2 Plus (Breeder), C2 Plus S (Breeder)	12-14
Broiler Breeder Male – rearing	0 -- 18 weeks	C2 Plus (Breeder), C2 Plus S (Breeder), G Plus (Breeder), G Plus S (Breeder)	11-13
Broiler Breeder Layer	17 + weeks	C2 Plus (Breeder), C2 Plus S (Breeder)	13 - 14
Broiler Breeder Layer	17 + weeks Hi-Yield	C2 Plus (Breeder), C2 Plus S (Breeder)	12 - 13
Broiler Breeder Male	17 + weeks	Revolution 8, G Plus (Breeder), G Plus S (Breeder)	8-10
Commercial Layer Pullet – rearing	0 – 20 weeks	Revolution 12, C2Plus, H2, H2 Plus	40-60
Commercial Layer	18 + weeks	Revolution 12, C2 Plus, C, H2, H2 Plus	30 - 40
Turkey Poult	0 – 5 weeks	Revolution 8, H2 Plus, H2, G Plus, G Plus S	60 - 65
Turkey Poult	0 – 10 weeks	Revolution 8, G Plus, H2 Plus, H2	40 - 50
Turkey Female	5 + weeks	ATF, ATF Plus	60
Turkey Male	5 + weeks	ATF Plus	40 - 50
Ducks	0 – 3 weeks	G Plus, G Plus S	60 - 70
Ducks	4 – 8 weeks	G Plus, G Plus S	50 - 60

***Notice:** Please be advised that the maximum number of birds that may be successfully produced per feed pan may vary based upon such factors as climate, housing type or style, bird breeds, genetic factors of the birds at issue, grower management practices, etc. All other environmental and management circumstances, such as proper bird density per house, access to adequate nutrients in feed, access to adequate water supply, proper ventilation, adequate health care for the birds, and other similar factors, must meet industry standards and recommendations, if any, of applicable bird breeder companies.

*** NOTICE:** The above Manufacturer's recommendations do not constitute a product warranty and are in no way to be considered as a guarantee of performance for poultry production. In addition, the above information in no way alters or revises the terms and conditions of any applicable Chore-Time manufacturer's warranty.

Planning the Suspension System

1. Select the House Layout.
 - A. See Figure 1..

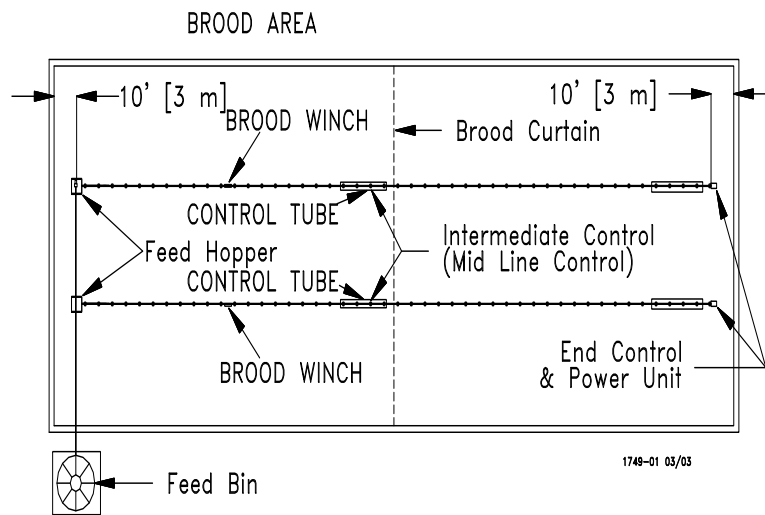

Figure 1. Component location diagram for systems up to 400 feet [122 m]. (Top View).

- B. Systems with line lengths over 400' [122 m] should be split in the center, as shown in Figure 2.. This will reduce auger running time.

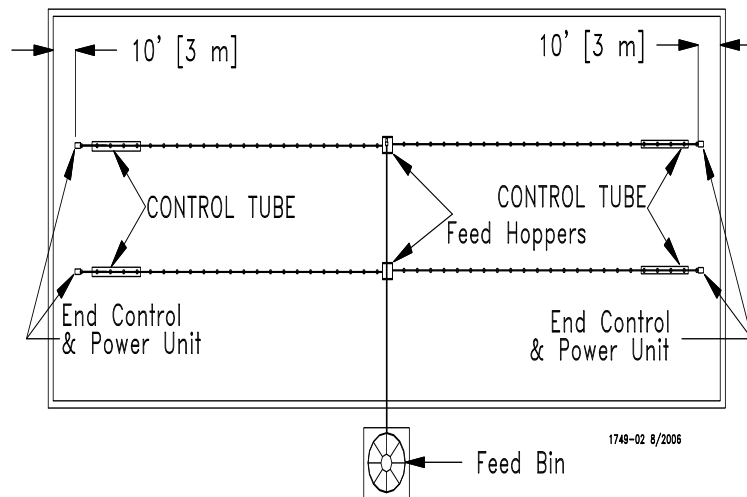

Figure 2. Component location diagram for systems over 400 feet [122 m]. (Top View).

2. Determine the Feed Bin location.
3. Determine the Brood Curtain location.
- 4. Determine the number of actuators (96 pans per actuator Maximum).**
5. Determine the location for the End Control Pans. **The Feeder Control Pans should be at least 10' [3 m] from the Wall or Brood Curtain.**
6. Determine the distance to the Feeder Line from the Side Wall.
7. Determine the distance from the Feed Hoppers to the End Wall for a Straight Line Feeding System.

General Installation Information

Please read the installation instructions in this manual prior to beginning the installation. This manual provides the necessary information on the installation, operation, and maintenance of the Chore-Time feeding equipment you have purchased.

The suspension, hopper assembly, feeder line installation, and anti-roost installation is the same for each system, except where noted otherwise. Please pay particularly close attention to insure proper assembly and installation of the equipment.

The REVOLUTION® 8 Rooster Feeder Control Units use a 348 RPM gearhead, delivering approximately 17 lbs [7.7 kg] per minute. Also available are control units using a 696 RPM gearhead, delivering approximately 35 lbs [15.9 kg] per minute. This rating is based on feed with a density of 40 lbs per cubic foot [640 kg per cubic meter].

Single phase 60 Hz and single and three phase 50 Hz Power Units are available for the REVOLUTION® 8 Rooster Feeders.

Systems up to 300' [91 m] require 1/3 HP. Power Units. Systems over 300' [91 m] require 1/2 HP. Power Units.

Laying out the Suspension System

1. Select the Suspension type.
 - A. For systems up to 350' [107 m]

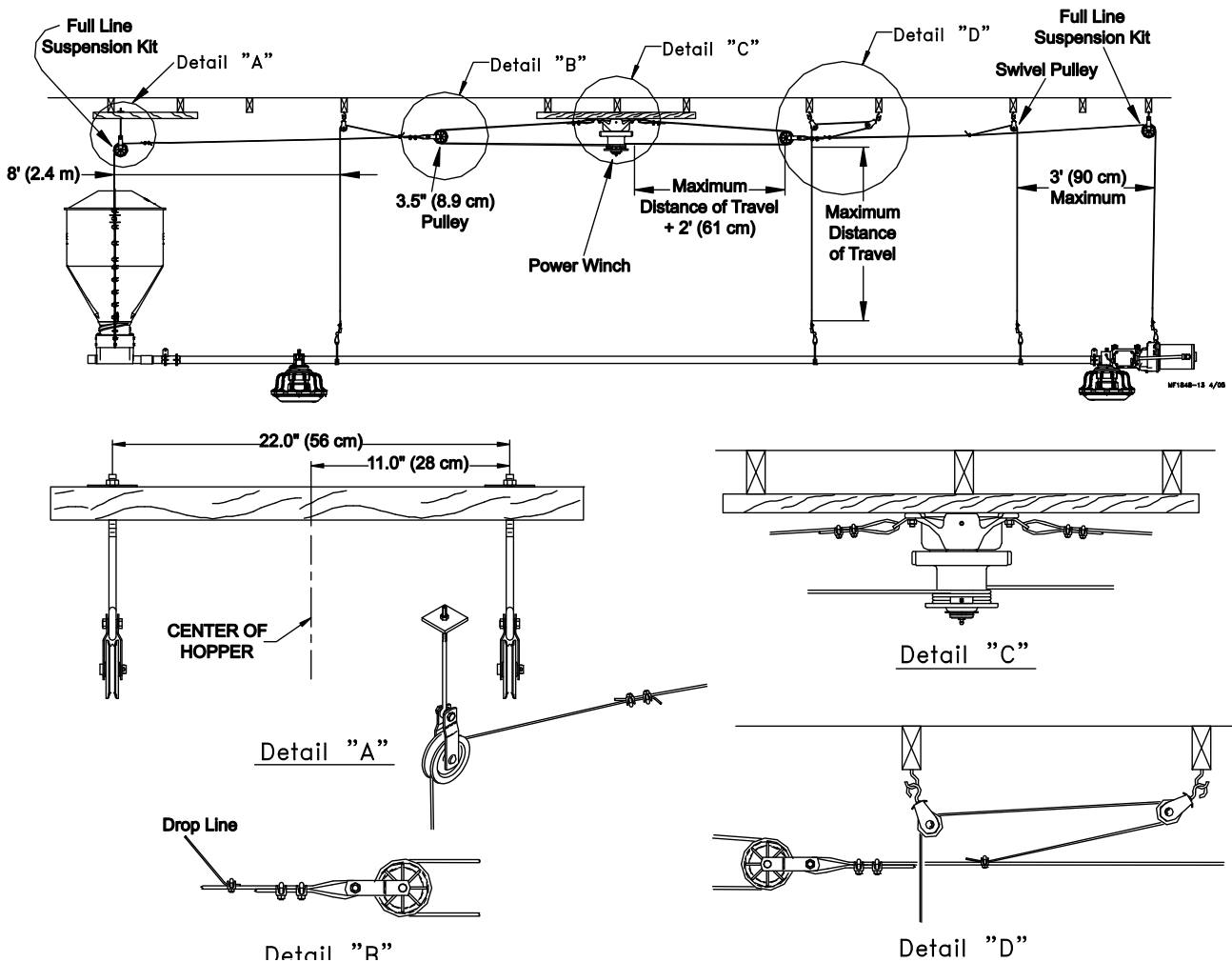

Figure 3. Suspension for systems up to 350' [107 m]

B. For systems over 350' [107 m]

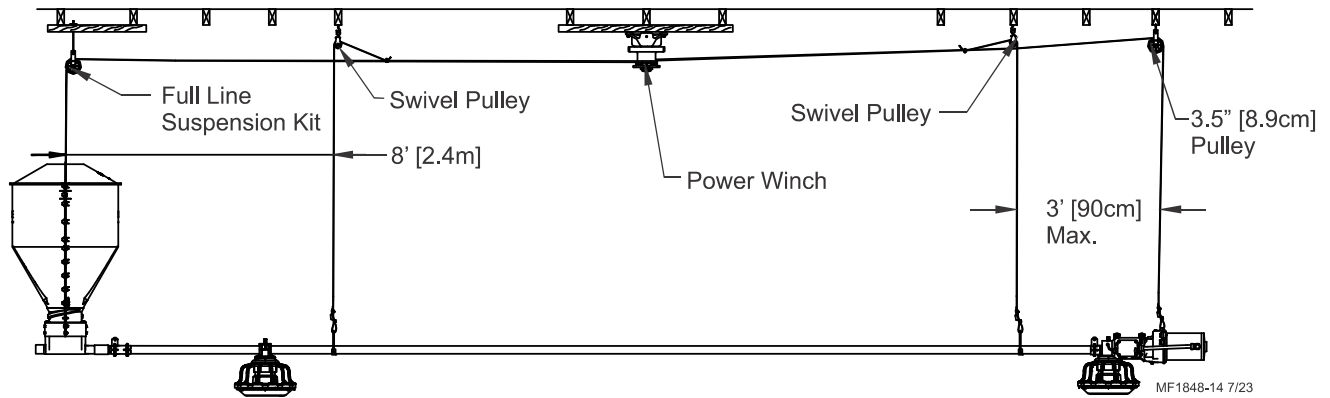

Figure 4. Suspension for systems over 350' [107 m]

2. Locate the power lift winch. The power lift winch requires a support that will span, in a wood frame house at least 3 rafters, and in a steel frame house at least 2 rafters.
3. Locate the power unit and feed hopper. Special support is required at each power unit and feed hopper location.
4. Determine the drop location and length. Suspension systems are based on ceiling heights of 14' [4.3 m] with suspension drop points every 8' [2.4 m]. **DO NOT EXCEED 10' [3 m] BETWEEN SUSPENSION DROPS.**
5. Determine the location for screw hooks. Mark a straight line or use cable to locate Screw Hooks. Use the offset of screw hooks where necessary.

Installing the Suspension System

Power Lift Winch Installation

1. Bolt the power winch, fully assembled, to the power lift winch support, either a 2" x 8" [50x200 mm] board that will span at least 3 rafters or a 3/8" [9.5 mm] thick steel plate welded to two pieces angle iron that are each long enough to span at least 2 rafters, using 5/16-18 hardware supplied in the hardware package. The brake mechanism will extend toward one side.

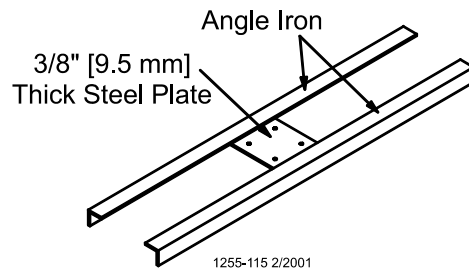

Figure 5. Optional Power Lift Winch support detail

Install a Cable Hook, supplied in hardware package, between the mounting bolt and power winch frame, as shown in **Figure 6**.

- Assembling the Power Winch to the Rafters
2. Attach the power lift winch support (with the power winch secured) to the ceiling at the center of the feeder line. See **Figure 7**. The power lift winch support must be parallel to the feeder line and must span at least 3 rafters in a wood frame house and 2 rafters in a steel frame house.

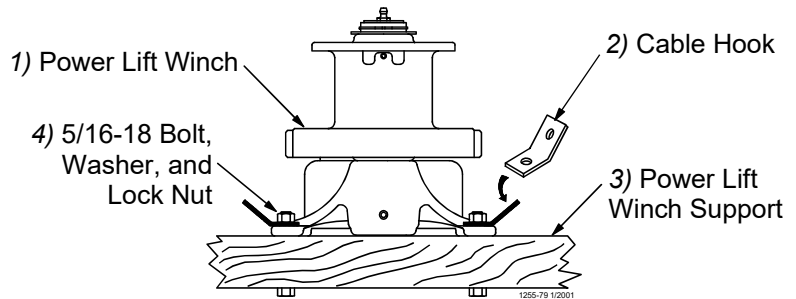

Figure 6. Assembling the Power Winch to the Rafters

If the hopper is located at the center of the feeder line, locate the power winch a few feet offset from the center of the feeder line. However, the winch drum must be directly in line with where the main cable is to be installed.

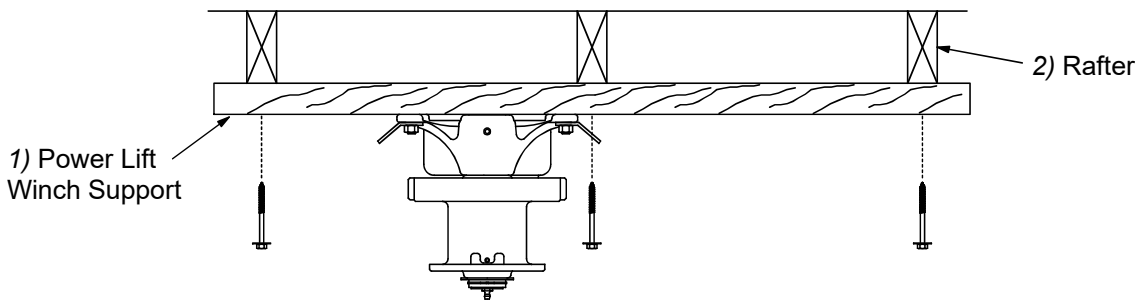

Figure 7. Mounting the Power Lift Winch and Support to the Rafters

Installing the Main Winch Cable

The suspension systems are based on ceiling heights of 14' [4.3 m] with suspension drop points every 8' [2.4 m]. DO NOT EXCEED 10' [3 m] BETWEEN SUSPENSION DROPS. Refer to suspension section in this manual for installation details.

Adequate overhead structure must be provided to support the weight of the feeders, hoppers, power units, etc. The suspension system is the same for the Rev. 12 and 8 Feeders. The type of installation required depends on the feeder line length.

IMPORTANT: Special support is required at each Hopper location.

•Power Unit Locations: **The Feeder Line must be supported within 3' [.9 m] of the Power Unit.** This is in addition to the required Power Unit suspension. If the Control Unit or Hopper does not come out directly under a truss, fasten a pulley to a 2" x 8" [50 x 200 mm] board or steel angle that will span 2 trusses and is capable of supporting 300 lbs [136 kg] for the Hopper and 75 lbs [34 kg] for the Control Unit.

•Feed Hopper Locations: **When steel hoppers with center suspension are used, see figure 8, the feeder line must be supported within 1' [30 cm] of the feed hopper.** When plastic hoppers are installed only 2 point suspension can be used, see figure 9, this does not require additional supports. See page 16 for plastic hopper suspension. This is in addition to the required feeder hopper suspension. After determining the type of suspension system required, decide where the feeder line is to be installed. Mark a straight line on the ceiling or rafters the full length of the feeder line. Use a string, chalk line, or the winch cable, temporarily attached with staples, to mark the line. Center the line directly over where the feeder line is to be installed.

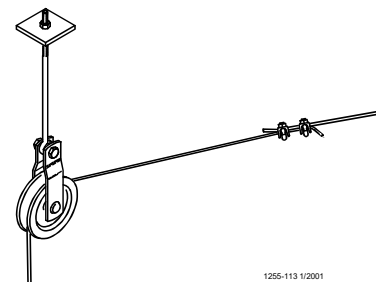

Figure 8. Steel Hopper Suspension

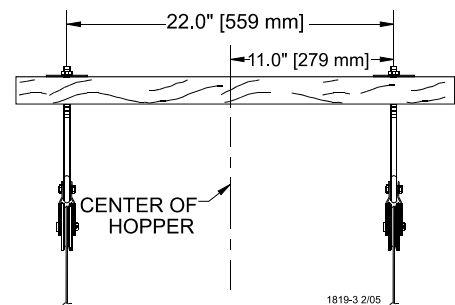

Figure 9. Plastic Hopper Suspension

3. Extend the 3/16" [5 mm] main winch cable the full length of the feeder line. Attach the cable temporarily to the ceiling with nails, staples, or some type of fasteners. **Figure 10** shows a double back arrangement for feed lines over 350' [107 m].

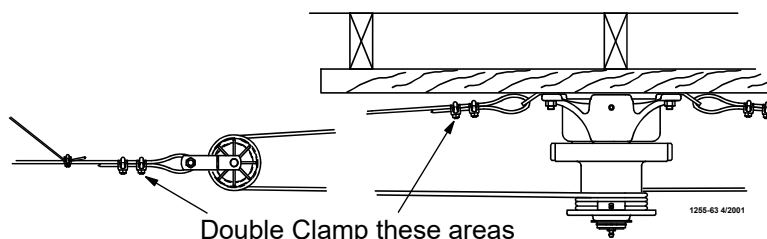

Figure 10. Double back arrangement for feed lines over 350' [107 m]

- Route the cable through the winch drum relief located near the bottom of the drum. Tighten the set screw to anchor the cable to the drum. See **Figure 11**.

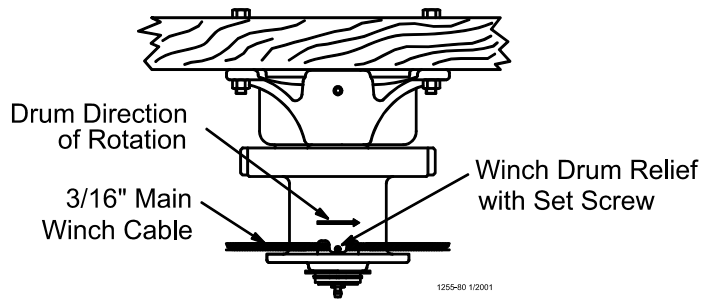

Figure 11. Attaching the Cable to the Power Winch

- Turn the winch drum one full revolution. Guide the cable against the flange at the bottom of the winch drum. The cable must not wrap over itself on the drum, but should be wrapped as close as possible to each previous wrap. See **Figure 12**.

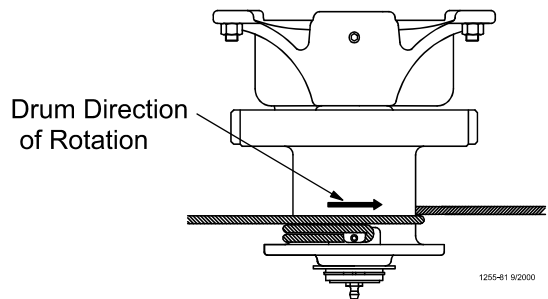

Figure 12. Power Winch Drum Rotation

Screw Hook Installation

The recommended distance between the drops is 8' [2.4 m] on center. Do not exceed 10' [3 m] spacing on drop lines.

If the distance raised is greater than the distance between the drop spacings, offset the hooks 3" [7.6 cm] to each side of the line to prevent the cable clamps from catching the pulleys, see **figure 13**.

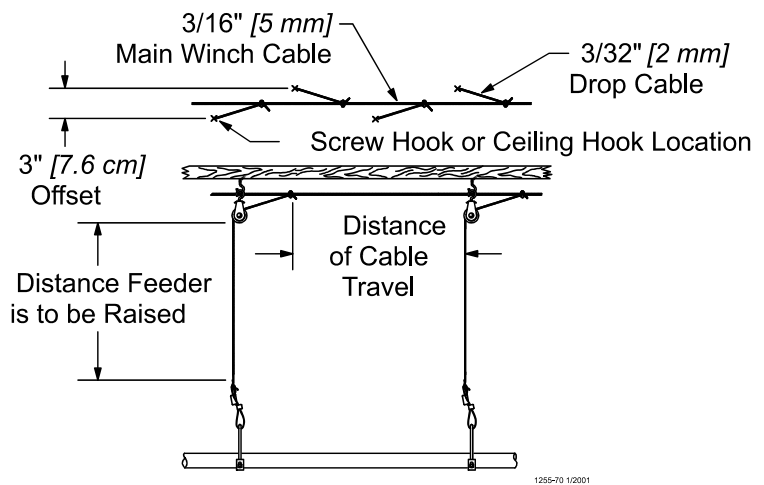

Figure 13. Drop Line Off Set Detail

Screw the hook into the truss the full length of the threads to prevent bending.

The openings of the screw hooks must be pointed away from the direction of travel when the power winch raises the feeder line. See **Figure 14**.

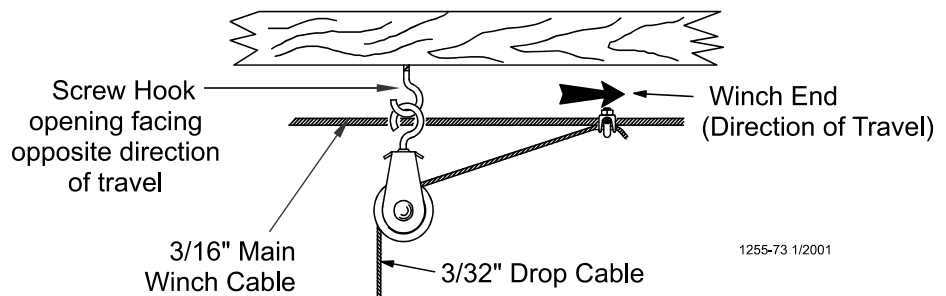
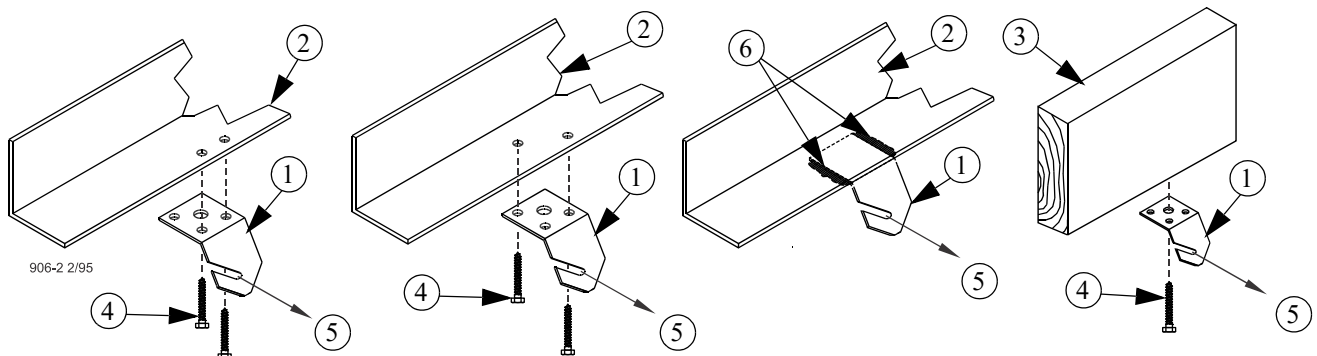

Figure 14. Screw Hook Installation

Ceiling Hook Installation

The ceiling hook may be used in a variety of installations. Depending on your ceiling or rafter type, install the ceiling hooks as shown in **Figures 15 - 16**.

Ceiling Hook Installation



Item	Description	Part No.
1	Ceiling Hook	28550
2	Steel Truss	--
3	Wood Truss	--
4	1/4-20 Lag Screw	--
5	Cable Travel Direction	--
6	Weld	--

Figure 15. Ceiling Hook Installation

6. After securing the ceiling hook to the truss, slide the hook of a swivel pulley into the slot, as shown in **Figure 16**.

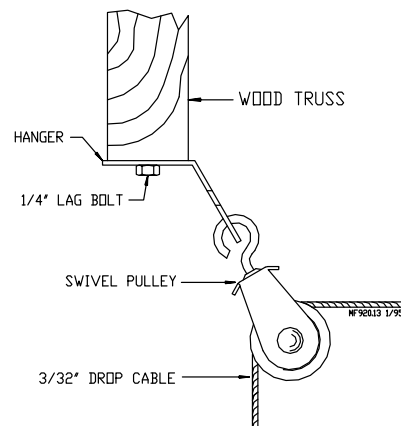

Figure 16. Pulley Installation

Drop Installation

Refer to **page 13 Figure 14**.

1. Attach a 3004 pulley to each hook.
2. Thread the end of the 3/32" or 1/8" cable through the pulley toward the winch. Clamp this end to the 3/16" winch cable about 6" [150 mm] from the last pulley, using a 3/16" cable clamp. See applicable figure; **Figure 14 or 17**.
3. Allow enough cable length for installation of the adjustment leveler. Sufficient cable is included to provide "throwbacks" on drops located beneath and near the winch. **Figure 17** shows a "throwback" cable arrangement.

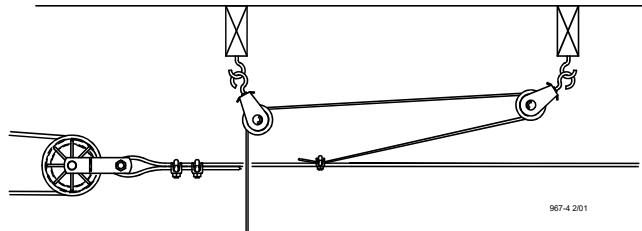

Figure 17. "Throwback" cable arrangement

4. **Begin installing suspension drops at the winch and proceed to the ends of the feeder line.** Keep the main cable tight between drops. It may be necessary to hang a weight on the end of the cable to maintain tension on the line.

Hopper Assembly Procedure

The 150 lb. Hopper Assembly is **NOT** designed for **single-point suspension**. The upper cross brace is designed for supporting the drop tube **ONLY**. This hopper assembly is to have **Two-point** suspension as stated.

Assembly

1. Assemble the 1/4-20 x 1-1/2" bolt to the brace with two 1/4-20 nuts. One nut should be assembled under the brace with the other on top. This bolt is to provide a place for the tube support assembly chain to be hooked, see **figure 18**.
2. Assemble the 150 lb. hopper halves and brace as shown in **Figure 18**, using #14 x 5/8" screws (supplied in hardware package).
3. Assemble the #8 x 1/2" screws and chain as shown in **Figure 18**.
4. Assemble suspension angles and suspension braces around feeder line boot (single or twin), using 1/4-20 x 1/2" Hex bolts and nuts (supplied in hardware package), see **figure 19**.

Note: The larger holes on the ends of the suspension angles need to be on the upper side of the assembly.

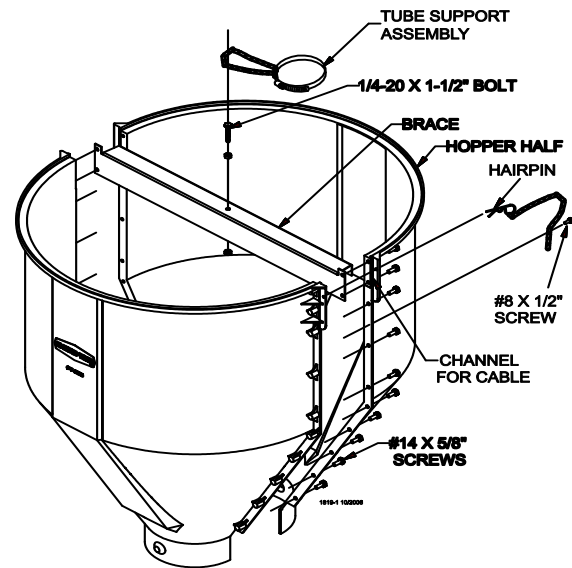

Figure 18.

5. Assemble the twist lock collar to the top of the feeder line boot (single or twin) using 1/4-20 x 1/2" bolts and lock nuts (supplied in hardware package), see **figure 19**.
6. Assemble the adjustment brackets to the suspension angles with 5/16-18 x 3/4" bolts and nuts (supplied in hardware package).
7. Two cable assemblies (cable with a sleeve clamp and a 5/32 thimble) are supplied with the suspension kit to support the hopper. Attach the cable assemblies to the adjustment brackets using the top holes of the adjustment brackets, see **figure 19**.

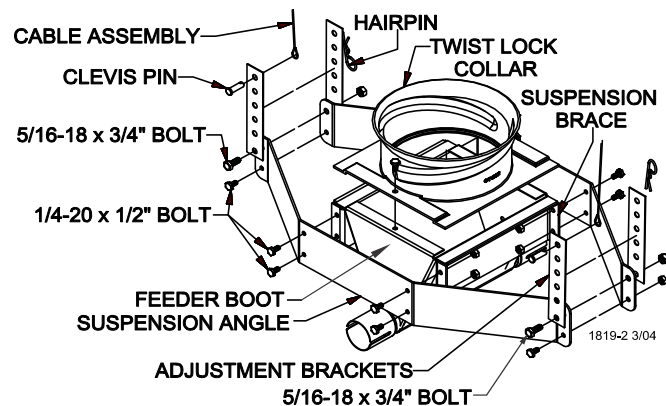

Figure 19.

8. Install two pulleys to either a 2" x 8" [50x200 mm] board that will span at least 3 rafters or a 3/8" [9.5 mm] thick steel plate welded to two pieces of angle iron that are long enough to span at least 2 rafters. Install the pulleys directly above the feeder line where the hopper is to be located. The pulleys should be spaced 22" [559mm] apart (11" [279 mm] from the center of the hopper in both directions), see **figure 20**.

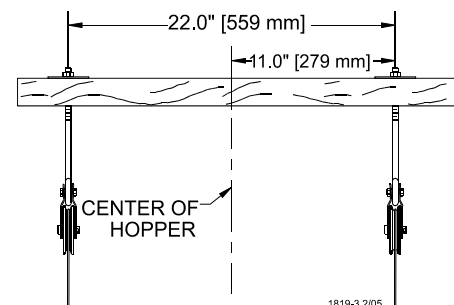
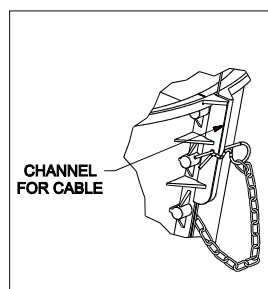

Figure 20.

Suspend the Hopper

1. Attach the boot to the feeder line.
2. Route the two cable assemblies up and around the pulleys.
3. Level the boot with the feed line and clamp the cables to the main cable using 1 cable clamp per cable assembly.
4. Place the hopper on top of the twist lock collar and rotate the hopper 90 degrees into position.

Make sure the cables lay in the channels on the sides of the hopper for support then use the hairpin to contain the cable.

Window Cone (Fill In Air) Systems see the following sections;

“Feeder Pan Assembly (Window Cone System)” on page 18

“Feeder line planning (Window Cone System)” on page 21

“Feeder Line Assembly and Suspension (Window Cone System)” on page 23

“Actuator Installation (Window Cone Systems)” on page 28

Indexing Systems see the following sections;

“Feeder Pan Assembly (Indexing System)” on page 33

“Feeder Line Assembly & Suspension (Indexing System)” on page 36

Feeder Pan Assembly (Window Cone System)

All feeders assemble in the same manor. Refer to **Figure 23 and 25**. The inner cone must turn freely. Align the threads on the outside of the adjustment cone and the grill cap. Turn the cone assembly into the grill cap. Continue turning grill until the pointer lines up with the #2 position. See **Figure 23**. Turn the grill and cone assembly over place the feeder pan on the grill, turn the pan clockwise until the lock engages. Assemble the remaining Feeders. Assembly Box Construction for REVOLUTION 8 Feeders.

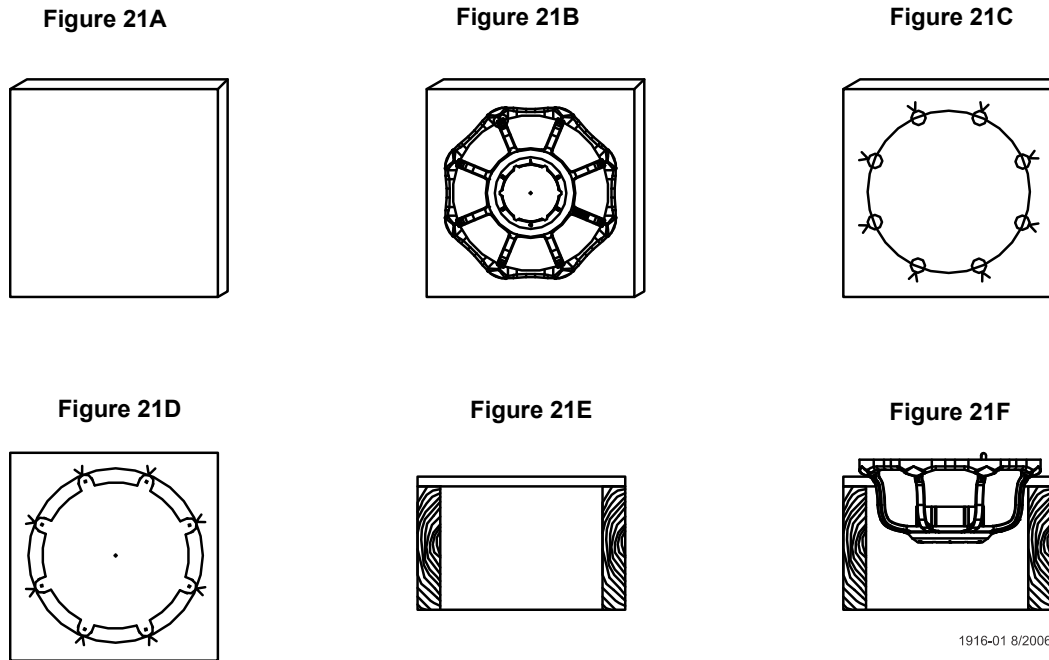

Figure 21. Assembly Box Construction

This information and assembly only applies to REVOLUTION 8 feeder installations.

Chore-Time recommends building an assembly box to aid in assembling the REVOLUTION 8 feeders for pan assembly procedure option 1 (see next page).

To build the assembly box use a 16" [406 mm] x 17" [432 mm] piece of plywood and two 14-1/2" and two 17" [432 mm] long pieces of 2" [51 mm] x 12" [305 mm].

1. Cut a piece of 3/4" [19 mm] plywood 16" [406 mm] X 17" [432 mm]. See **Figure 21A**.
2. Center the grill on the 16" [406 mm] X 17" [406mm] piece of plywood. Use a pencil and draw around the inside edge of the grill as shown in **Figure 21B**.
Mark a "V" at each strut location.
3. Remove the grill.
Use a 7/8" [22 mm] spade bit to drill a hole at each strut location, as shown in **Figure 21C**.
4. Use a sabre saw to cut along the *inside* circle, between the 7/8" [22 mm] holes. See **Figure 21D**.
5. Use (2) 14-1/2" [368 mm] and (2) 17" [432 mm] 2" [51 mm] x 12" [305 mm] to construct the box sides. Nail the 3/4" [19 mm] plywood fixture to the box. See **Figure 21E**.
It is important to use at least 12" [305 mm] sides for the box. Smaller lumber will not allow sufficient depth for the grill to be placed in the box face down.

Figure 21F shows how the grill should fit down in assembly box. NOTE: Board is cut away for clarity only.

Pan Assembly Procedure for REVOLUTION 8 Feeders (Option 1)

1. Place a Grill in the pan assembly box fixture.
2. Rotate brood adjustment until cover washer is flush with outer cone, see **figure 22**.

Rotate before installing grill

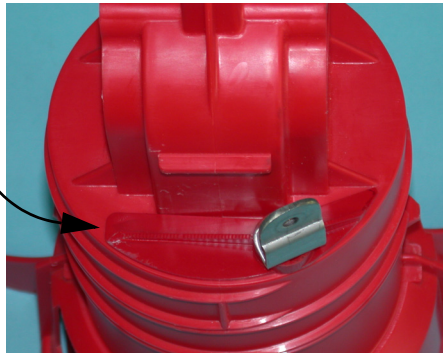
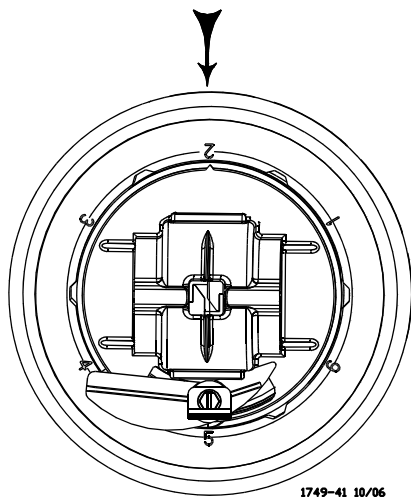

Figure 22. Rotate brood adjustment prior to grill installation.

3. Install cone assembly in the grill, **Check fit, correct, grill and cone should be snug, incorrect if grill and cone have free motion.**
4. Place the feed pan in the grill ring, The pan must be fully seated in the grill then rotate the pan until the pan locks in their grill

Align the threads on the support cone and the grill cap.



Adjustment of feed level to #2 position.

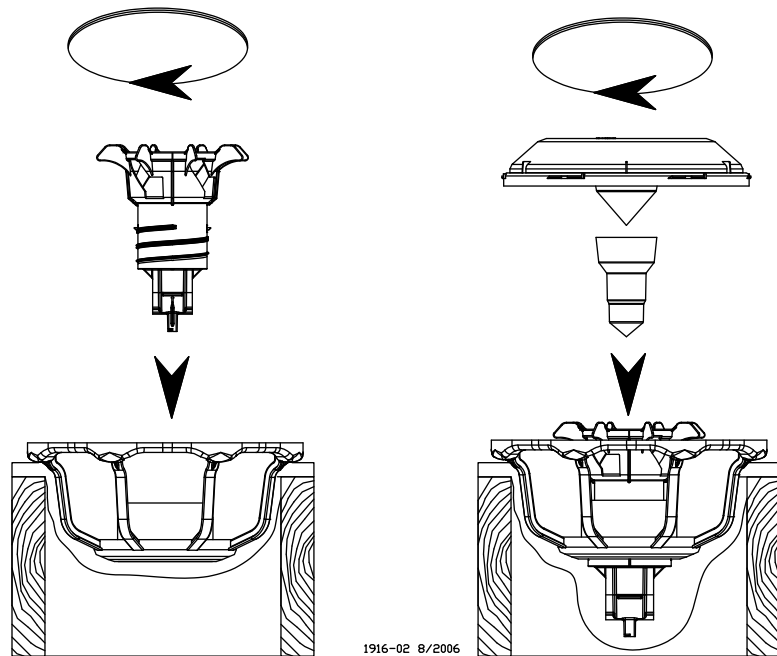

Figure 23. Pan Assembly Option 1

Pan Assembly Procedure for **REVOLUTION 8 Feeders** (Option 2)

1. Place cone assembly on a flat surface.
2. Rotate brood adjustment until cover washer is flush with outer cone, see figure 24.

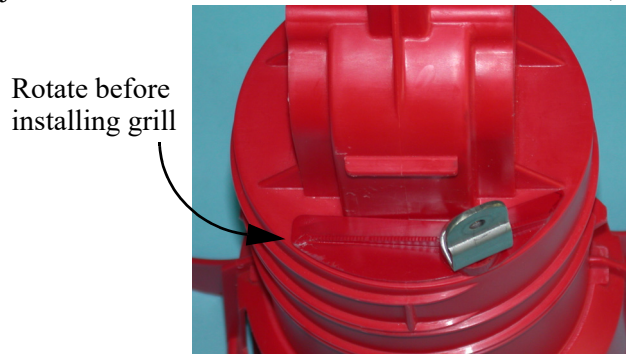

Figure 24. Rotate brood adjustment prior to grill installation.

3. Set grill over the cone.
4. Rotate the grill until the threads are started.
5. Continue rotating the grill until you reach position # 2.
6. Turn the assembly over then install the pan by rotating the pan until it latches.

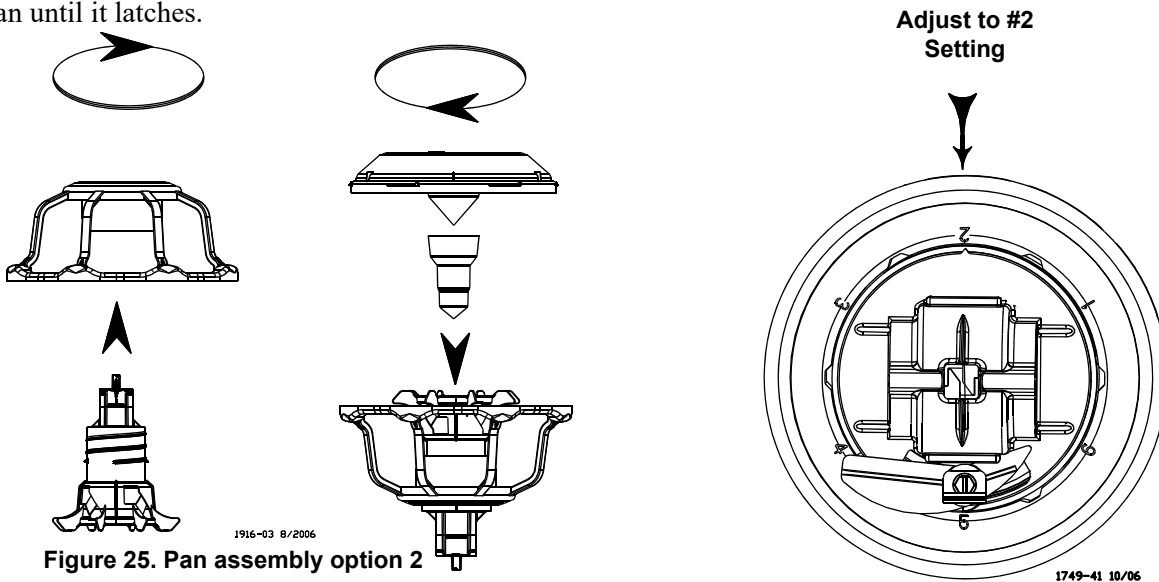

Figure 25. Pan assembly option 2

Installing the Pivot Clip.

Loosely assemble the pivot clip to the pivot bracket using the supplied 10-24 x 3/8" [9.5 mm] screw.

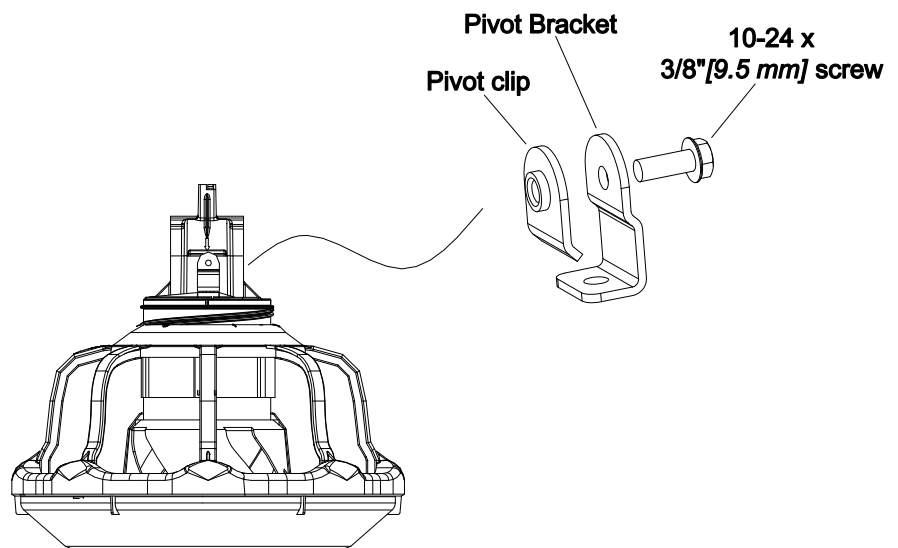

Figure 26. Installing the pivot clip

Feeder line planning (Window Cone System)

ACCU-CLICK™ Actuator

Layout figured on 96 pans.

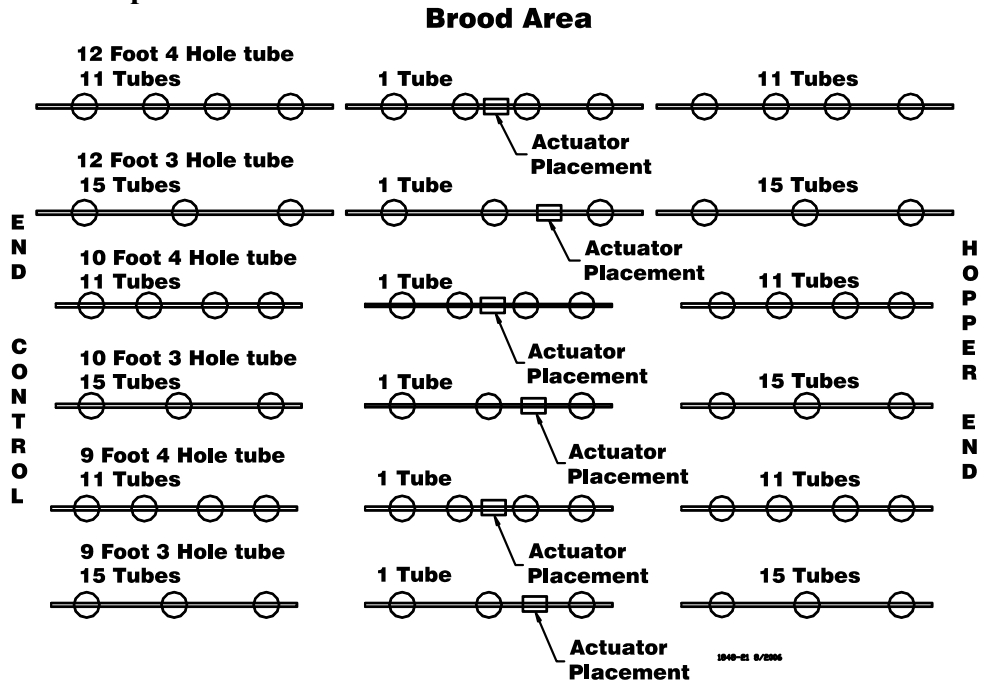

Figure 27. Typical building layout for Actuator placement.

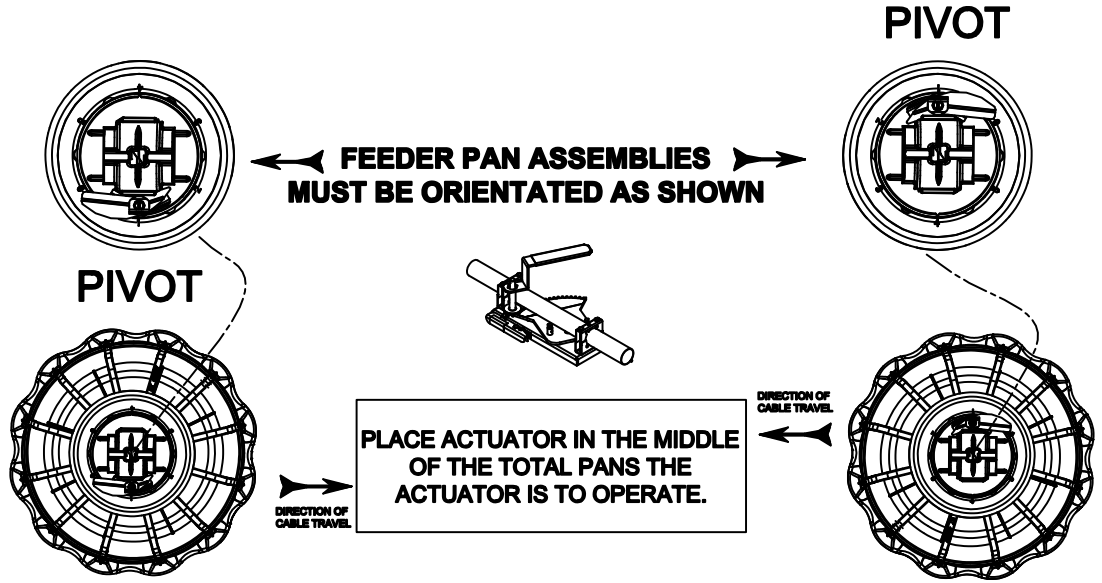

Figure 28. Pan orientation on feeder tube.

Determine the feeder layout you will be installing. Assemble the feed pans on the tubes according to the layout above.

Assemble the correct number of tubes with the pivot bracket on the correct side of the pan.

To ensure the pivot bracket is assembled on the correct side, stand over the actuator looking at the belled end of the tube. The pans in front of you will have the pivot bracket on the left, while the pans behind you will have the pivot bracket on the right.

Example: For a 9 foot tube you will assemble 6 tubes with the pivot bracket on the left side and 6 tubes with the pivot bracket on the right side.

Below is an overview of the feeder installed with the tension pulleys and actuator wire installed.

It is very important that the pans be installed with the pivot bracket on the correct side!!!

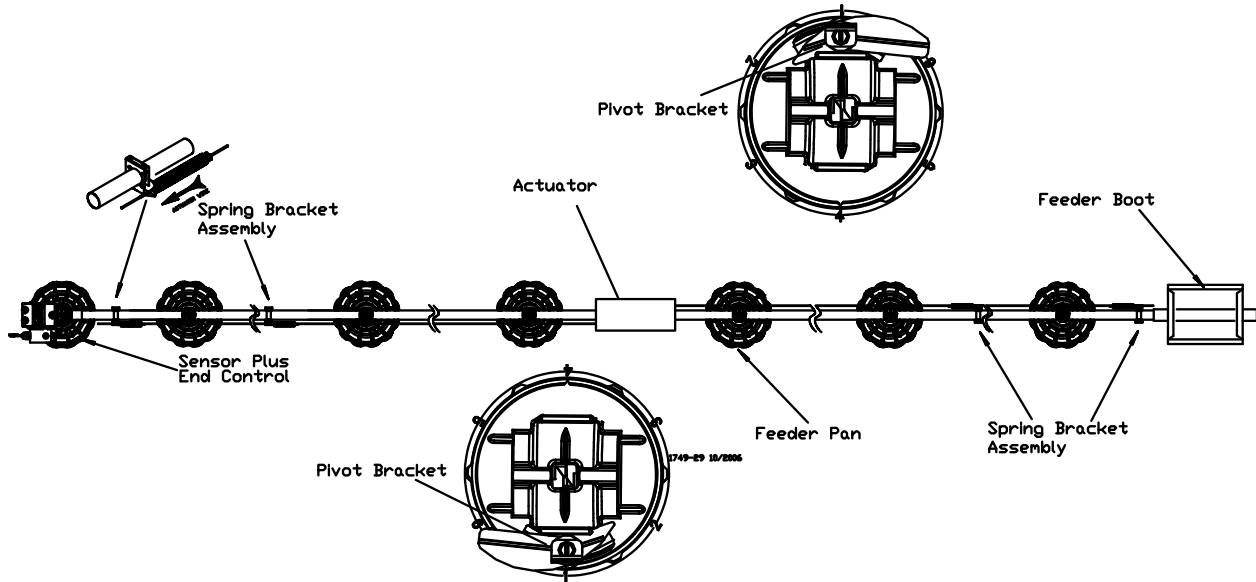

Figure 29. Feeder layout

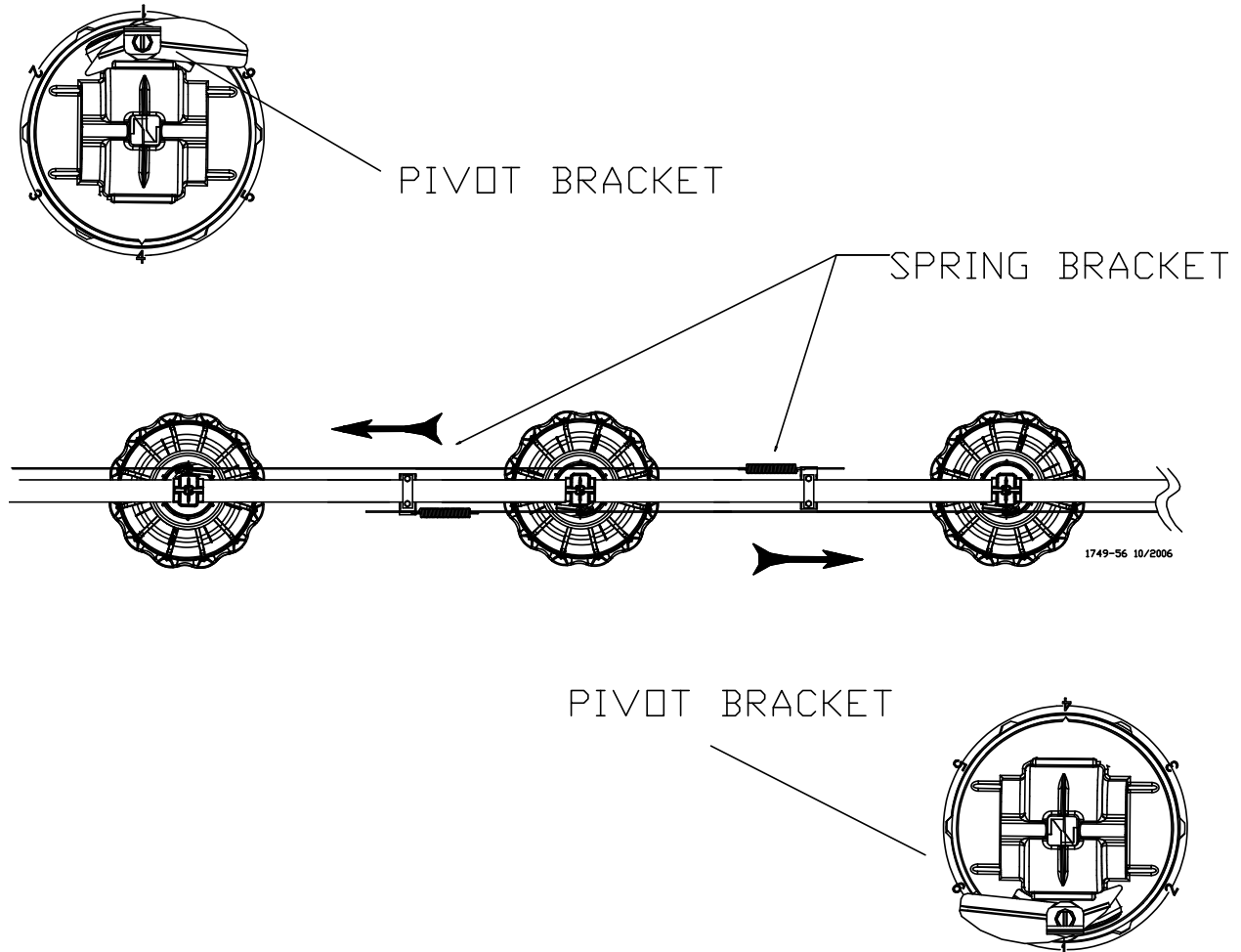

Figure 30. Terminal Spring Brackets

Feeder Line Assembly and Suspension (Window Cone System)

ACCU-CLICK™ Actuator Installation

The actuator assembly is to be installed in the middle of the total pans the actuator is to operate. Using two half clamps provided with the actuator attach the actuator assembly to the feeder tube between two pans. **The two halves of the clamps are not the same.** The wider half will attach to the base of the actuator. The other half will be installed over the tube, sliding into the wider half of the clamp.

When Installing the Actuator the Tube Seam must be on the side opposite the Actuator Handle, see figure 31. It may be necessary to use a tube closure kit if the actuator is to be placed near a feed outlet hole on the tube.

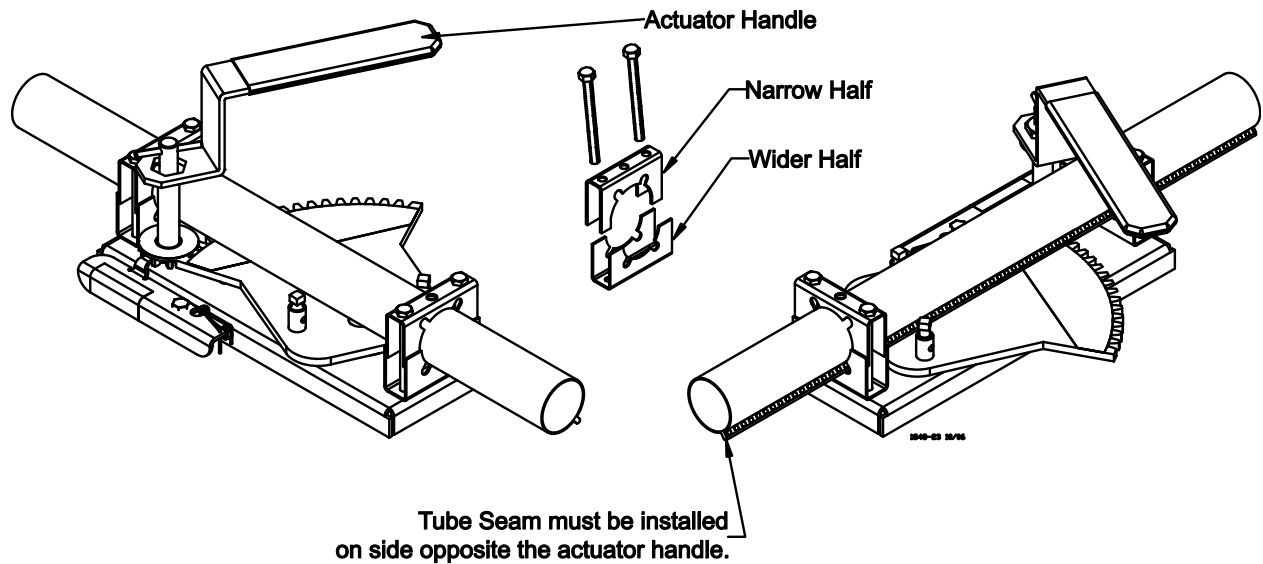

Figure 31. ACCU-CLICK™ Actuator installation

Feeder Pan and Tube Assembly Process

1. Slide one Feeder Pan Assembly per hole onto the auger tubes.
IMPORTANT: Install all the feeders on the tubes in the same orientation.
When sliding the feeders on the tubes, make sure the pivot brackets are on the same side of the tube.
2. **IMPORTANT: Tube Closure kits will need to be installed on the auger tubes at each hole a feeder pan assembly is not installed at.**
3. Rotate the auger tubes so that the seam is down, this holds the Pan Assemblies in place on the tubes. See Figure 32.

1) With the seam of the feeder tube up, slide the pan assembly on the feeder tube. Position one (1) feeder pan over each hole to be used on the feeder tube.

2) Install a tube closure kit at each hole in the feeder tube that does not have a pan assembly at.

3) Rotate the feeder tube after the feeder pan assemblies are in place. This will lock the feeder pan assemblies in place.

PIVOT BRACKETS MUST BE ON THE SAME SIDE OF THE TUBE.

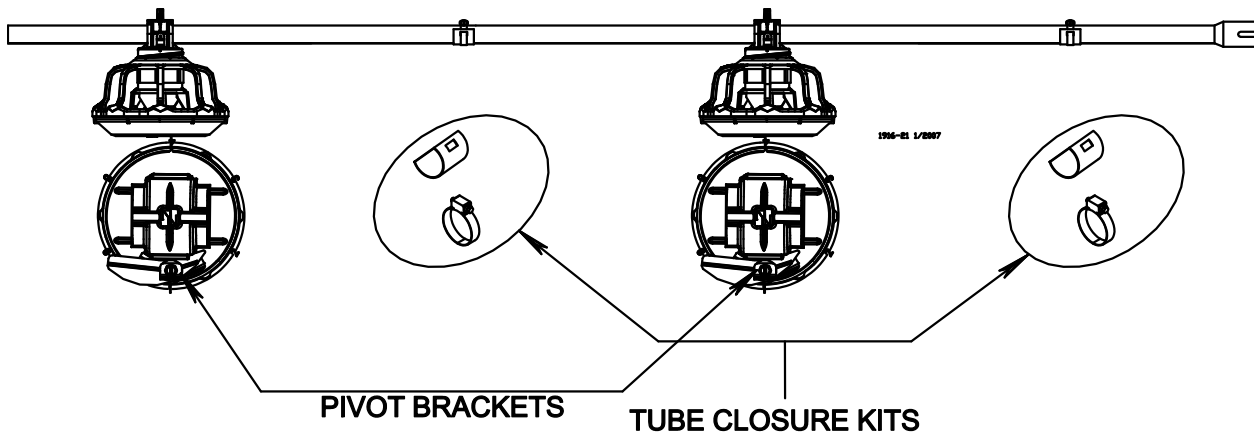

Figure 32. Assemble Feeders on tubes

Assemble half the tubes with the pivot bracket on the left side and half on the right side. The tubes with the actuator mounted will have different pivot bracket orientation on the same tube.

Example: A 9 foot tube will have two pans on the left side and two pans on the right side.

Assemble and Suspend the Feeder Line

1. The actuator, auger tubes and feeders may be laid out end to end in approximately the final location of the line. **The belled end of each tube should be toward the (3) Hopper end of the line. See Figure 33.** Be sure to have the correct number of tubes and the actuator is in the center of the section to be controlled by an actuator. **Place the actuator between the tubes near a suspension drop.** All actuators must be installed in the same direction. One actuator handles up to 96 feeder pans with the actuator placed dividing the (96) pans approximately in half.
2. Connect the individual feeder tubes together by inserting the straight end of one tube as far as possible into the (2) belled end of the next tube. **The last Feeder Tube before the (1) End Control Pan must be a Control Tube.**

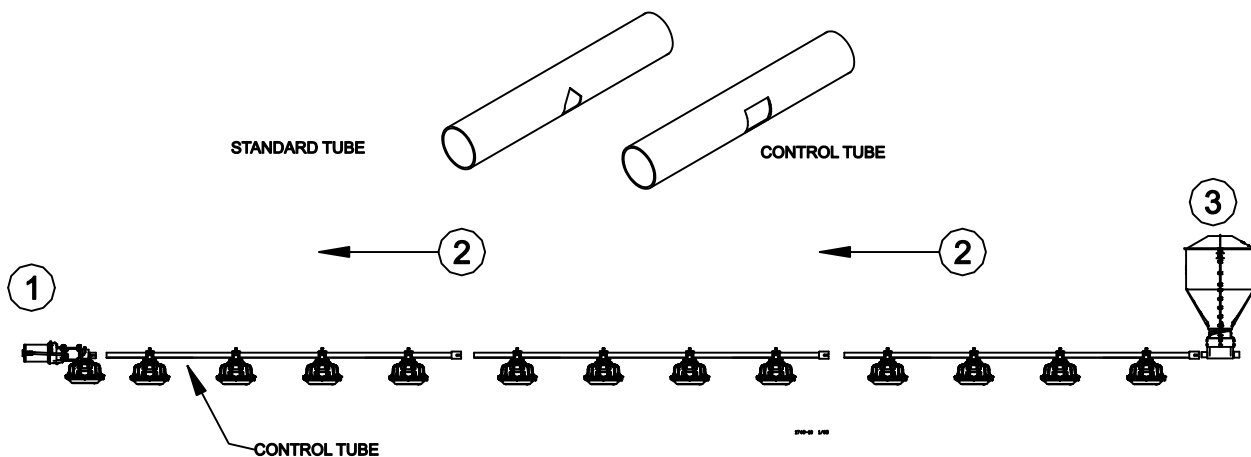
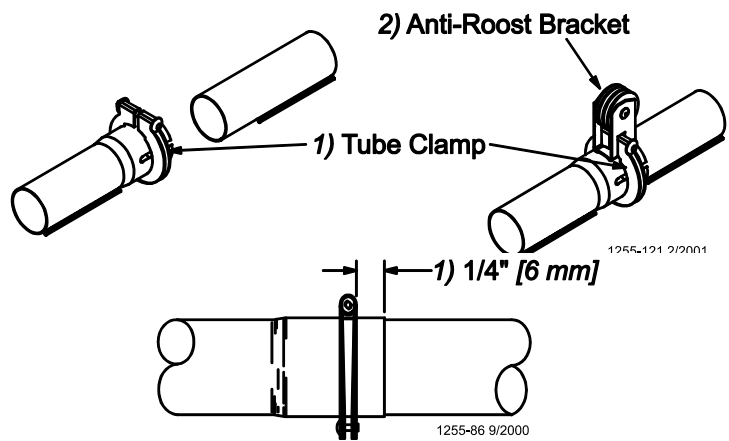

Figure 33. Attaching Feeder Tube Assemblies

3. Place a Tube Clamp Assembly or Clamp/
Anti-Roost Bracket at each joint. **Figure 34**
shows the standard Clamp and Clamp/
Anti-Roost Bracket.

Systems using 9' Auger Tubes require a Clamp/
Anti-Roost Bracket at every **fifth** joint.

Systems using 12' tubes require a Clamp/
Anti-Roost Bracket at every **fourth** joint. All
other joints in the system use the standard
Tube Clamp Assembly.



4. Continue down the feeder line until each tube
joint has a standard Tube Clamp or Clamp/
Anti-Roost Bracket. Do not tighten at this
time.

5. The Adjustable Hanger is used to hang the
feeder line. It is also used to index the feeder
line.

6. Make sure the Adjustable Hanger is facing the
proper direction, as specified in **Figure 35**.

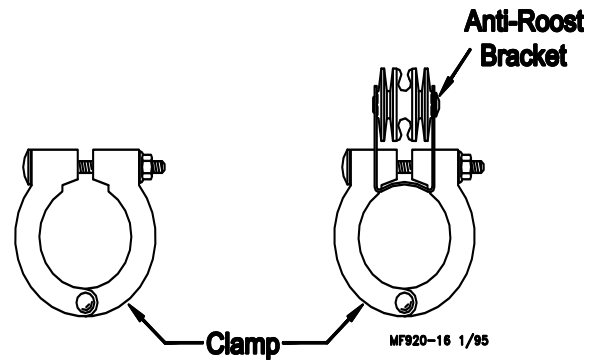

Figure 34. Tube Clamps

Setting Example: If the appropriate setting for the
Auger Tube is D5, the “S” Hook should be
installed in the #5 hole in the Hanger. The
Auger Tube Seam should be in the “D”
position, see **figure 36**.

**Program each Auger Tube in the feeder line to
“E5” for total feed drop out.**

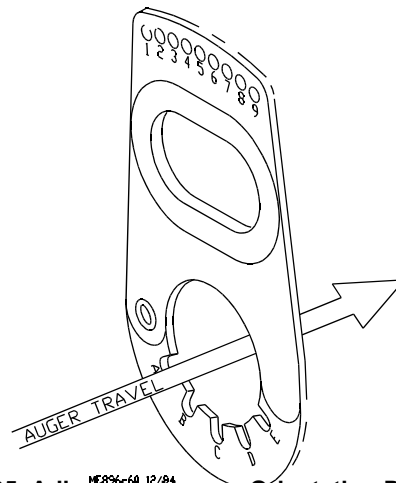

Figure 35. Adjustable Hanger Orientation Diagram

7. Install Adjustment Leveler within 6" [152 mm] of feeder line. **Figure 37** shows the proper cable routing around the Adjustment Leveler.

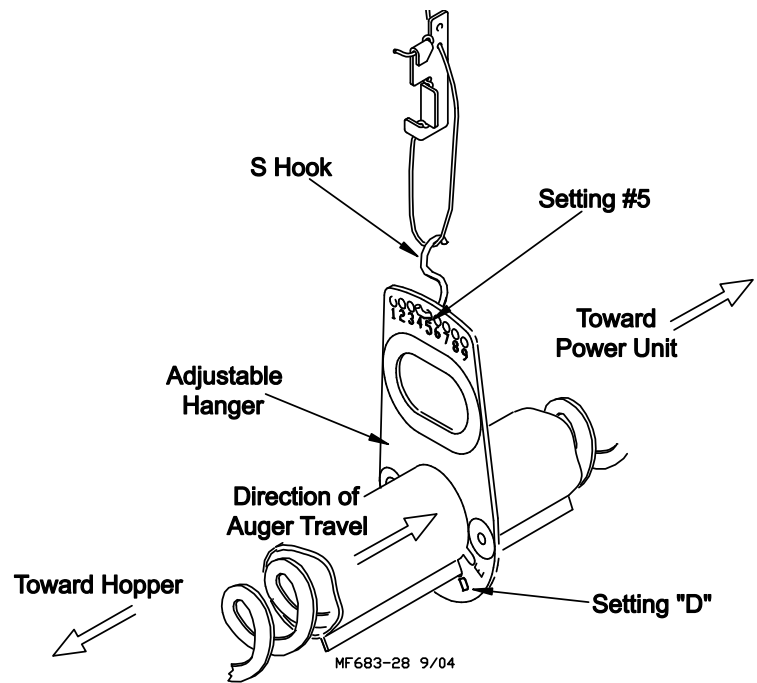

Figure 36. Indexing the Feeder Line

8. Following the installation of all drops, check drop cables before raising feeder line. Cable must be tracking properly on all pulleys before raising the feeder line.
9. Raise the feeder line to a convenient working height.
10. With the feeder line suspended, measure from the floor or ceiling to the auger tubes to level the system.
11. Before tightening each clamp:
 - make sure each tube is level (not sagging, sloping, etc.).
 - make sure straight end of each tube is fully inserted in belled end of next tube.
 - if providing total drop out, tubes should be rotated so that the Chore-Time Logo is on crown of tube.
 - make sure the clamps are located, as shown in **Figure 34**.
 - when tightening the actuator tube the top must be flat.

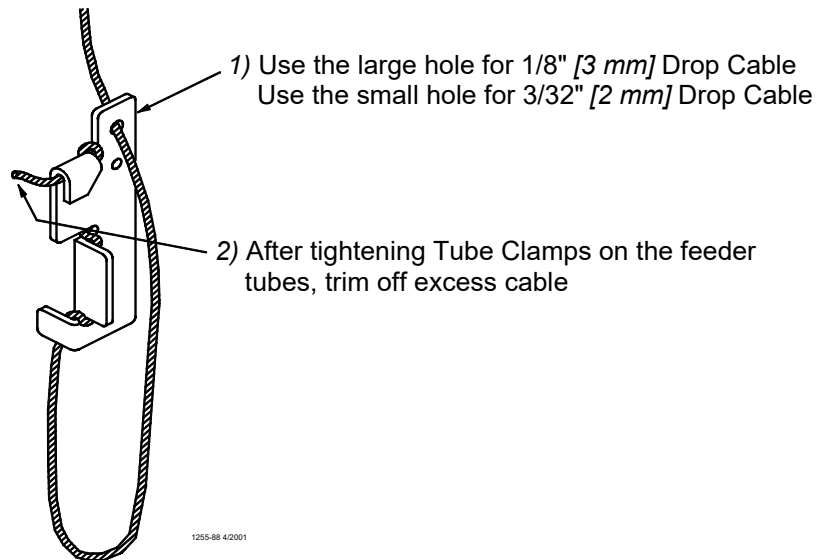

Figure 37. Cable Lock Threading

Finally, tighten the Tube Clamps on the feeder tubes. Clamp the joints securely, but do not crush the tubes. Re-adjust all Adjustment Levelers as needed and trim off excess cable as shown in **Figure 37**.

Anti-Swing Installation

The anti-swing clamps are designed for breeder and rooster operations to prevent the feeders from swinging on the auger tubes.

Note: The seam of auger tube and hardware for the Lock must be on opposite sides as shown. Otherwise an interference will occur.

Install the adjustable clamp around the feeder tube. Slide the locking device into position and secure it in position with the adjustable clamp.

Make sure the feeder is in the upright position before securing the locking device to the auger tube using the adjustable clamp.

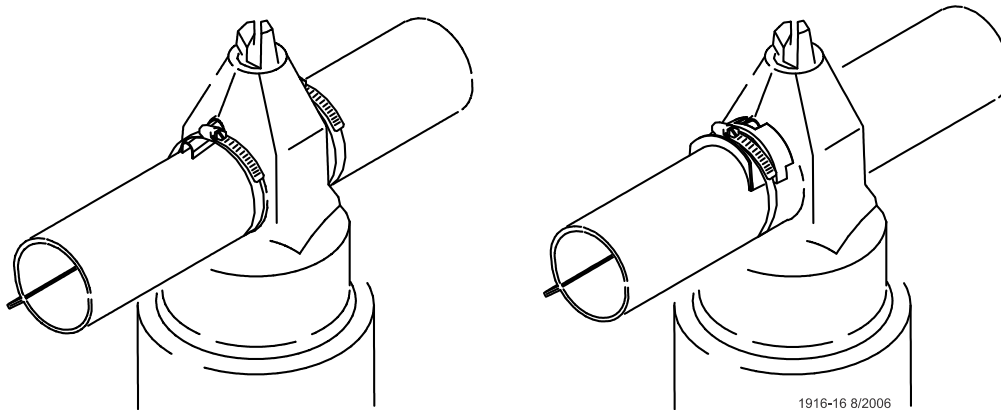

Figure 38. Feeder Anti-Swing Clamp Installation

Actuator Installation (Window Cone Systems)

Installing spring brackets:

1. Install the terminal spring and bracket (using (2) 1/4-20 x 3 inch hex bolts) at the control unit, **see figure 39 and 42**. If necessary the last pan may need to be setup to push the vari-brood opening, **see figure 41**.
2. Install the 2nd (intermediate) spring and bracket approximately 30 feet (3 Tubes) from the 1st terminal bracket.
3. Continue installing Brackets 30' apart using (2) 1/4-20 x 3 inch hex bolts.

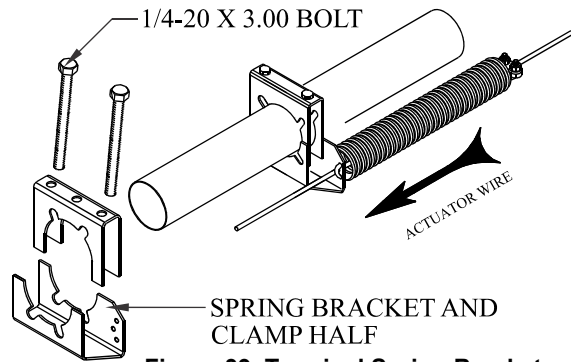

Figure 39. Terminal Spring Bracket

1749-46 10/06

4. Assemble the spring to the spring bracket by sliding the loop of the spring up through the third hole in the bracket, **see figure 40**.
5. Repeat the procedure for the opposite end and complete the installation of all spring brackets.
6. Max 48 pans each side of actuator.

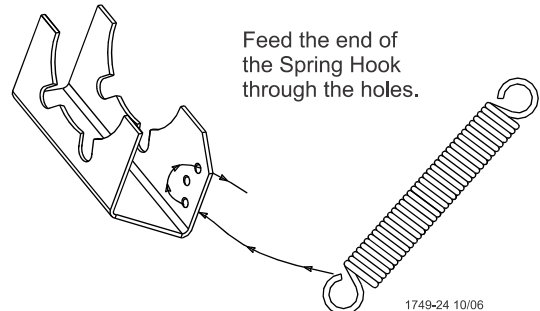

Figure 40. Spring Bracket Assembly

1749-24 10/06

Spring bracket installation for 9 foot 4 hole and 12 foot 5 hole tubes.

For these applications the last pan will be a pusher to actuate the vari-brood feed feature.

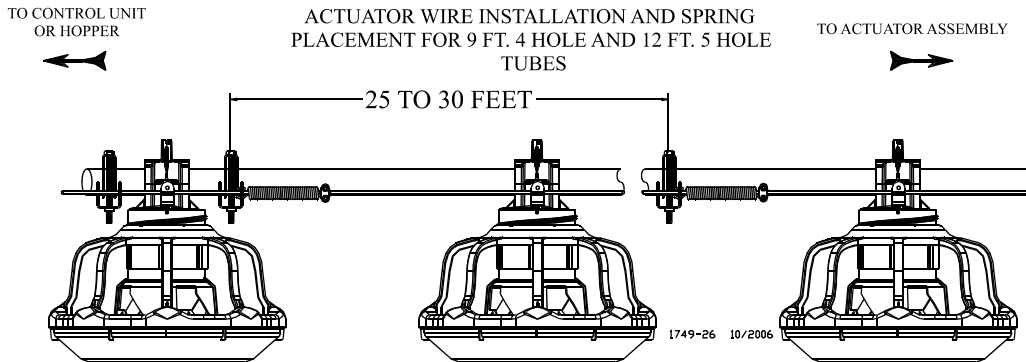

Figure 41. Wire layout for 9 ft. 4 hole and 12 ft. 5 hole

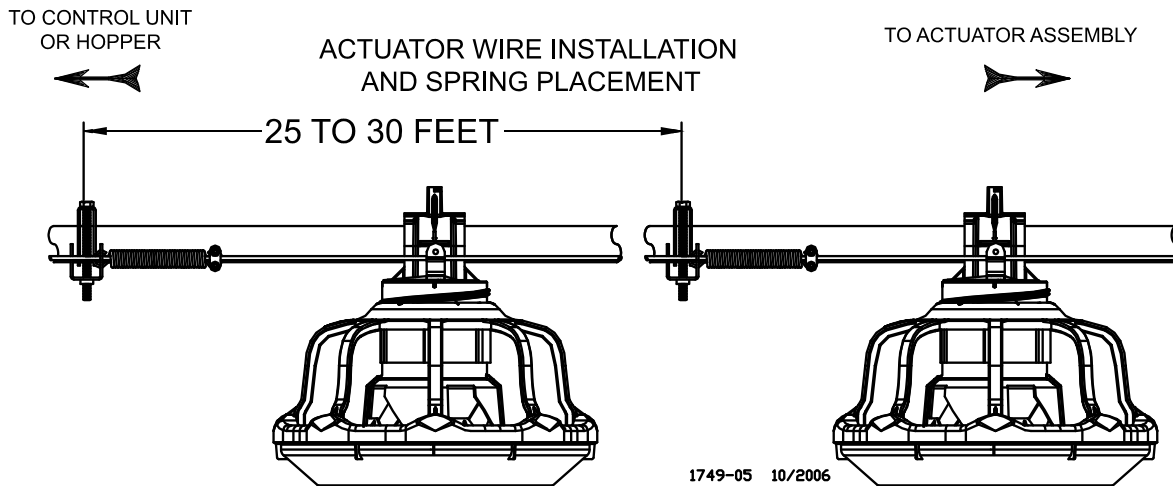

Figure 42. Wire layout for 10 ft. 4 hole and 12 ft. 4 hole

Unroll the actuator wire and lay the wire behind the pivot brackets on the feeders.

Do not allow the wire to feed from the side!! This will cause excess waves and kinks.

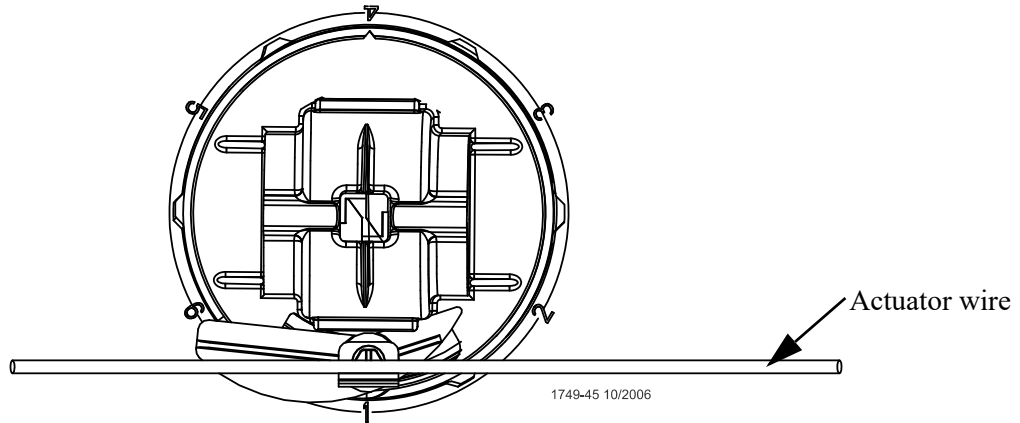
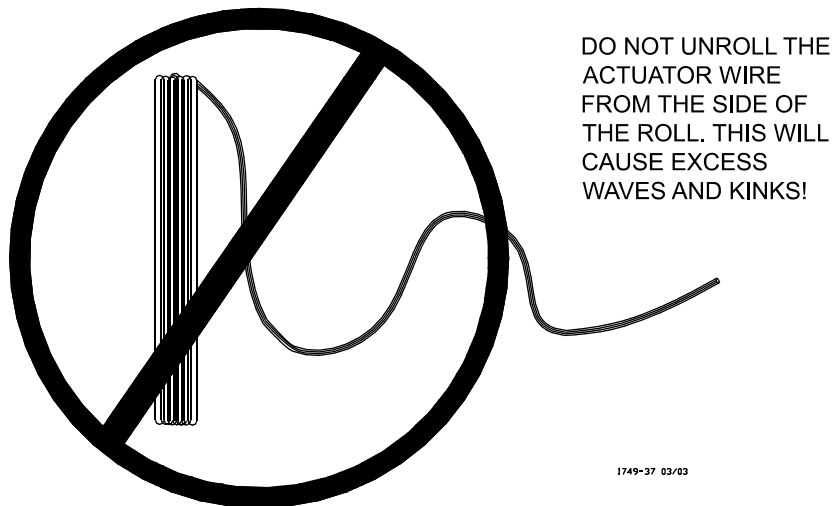
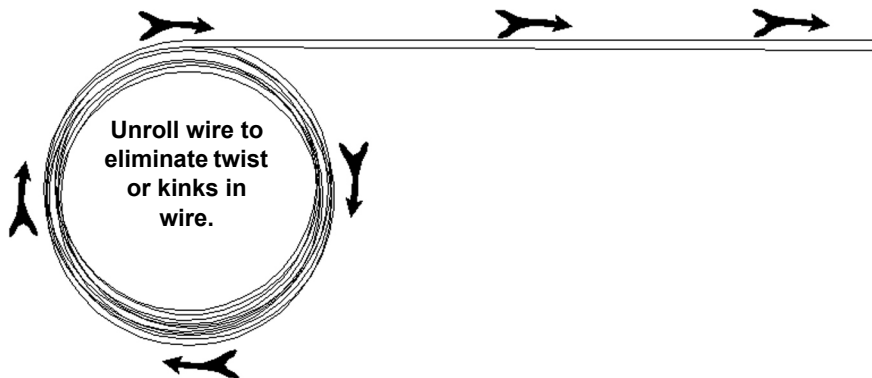

Figure 43. Lay actuator wire behind pivot bracket
Do NOT allow the wire to unroll from the side!!!



Do NOT allow the wire to unroll from the side!!!



This layout shows the correct way to unroll the actuator wire.

Installing actuator wire:

1. Beginning at the terminal spring bracket or if a pusher pan is used start at that spring bracket. Slide the end of the actuator wire through the two holes in the bracket and through the center of the end spring, **see figure 44**

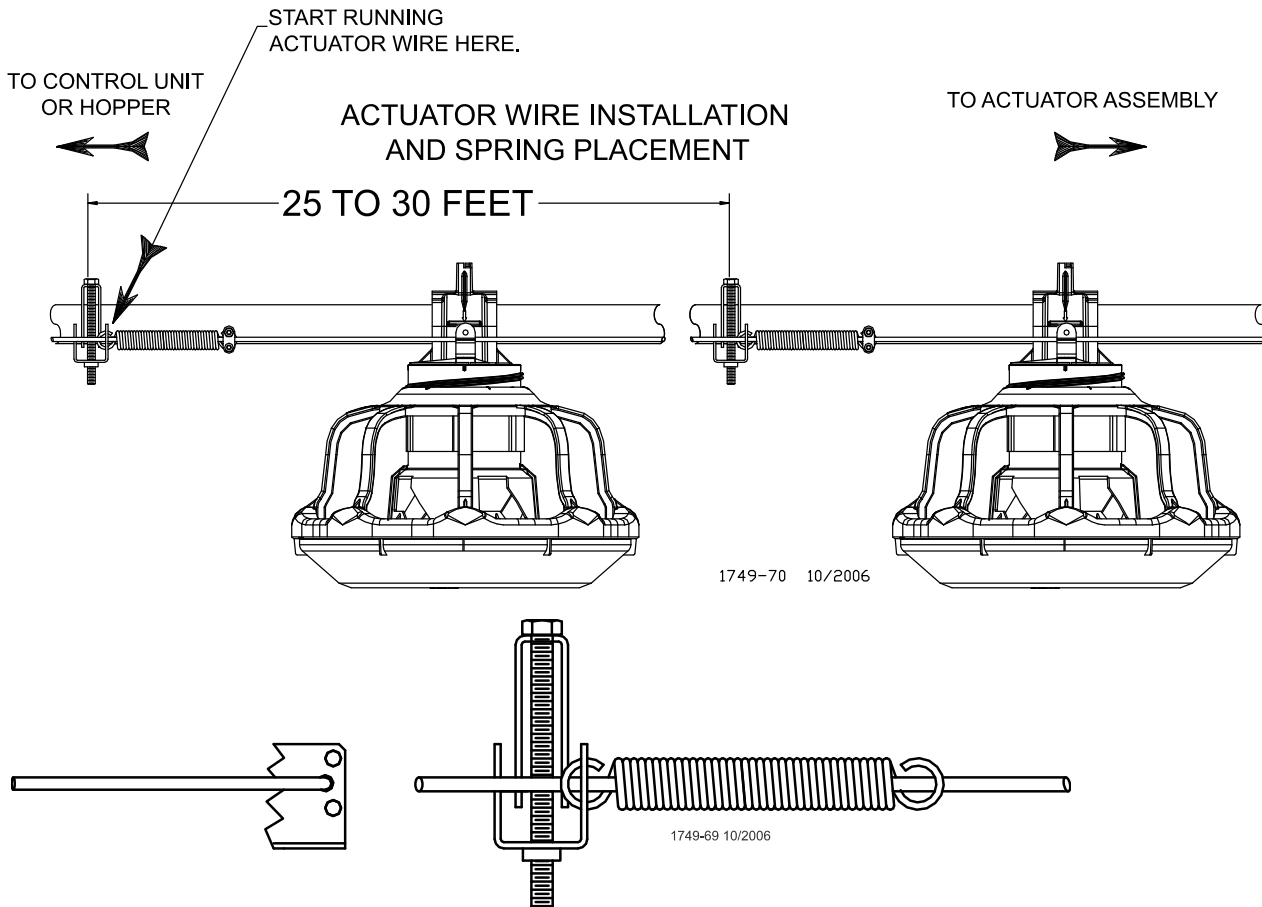

Figure 44. Installing actuator wire

2. Pull the wire through the spring and bracket until you reach the intermediate spring and bracket. Slide the end of the wire through the two holes in the bracket and through the center of the spring.
3. Continue pulling the actuator wire until you reach the actuator. (Lay the unrolled wire behind the pivot brackets, this will help to eliminate slack in the wire.)
4. At the actuator:
 - Position the actuator so the actuator is in the “Fully Open Brood Gate Position” (**see figure 45**) if it is not already in the “Fully Open Brood Gate position”.
 - Feed the actuator wire through the clevis pin on the actuator.
 - Allow a minimum of 2" [5.08 cm] of actuator wire to extend past the clevis pin then cut the actuator wire.
 - Tighten the set screws on the clevis pins so they clamp down on the actuator wire, **see figure 45**.

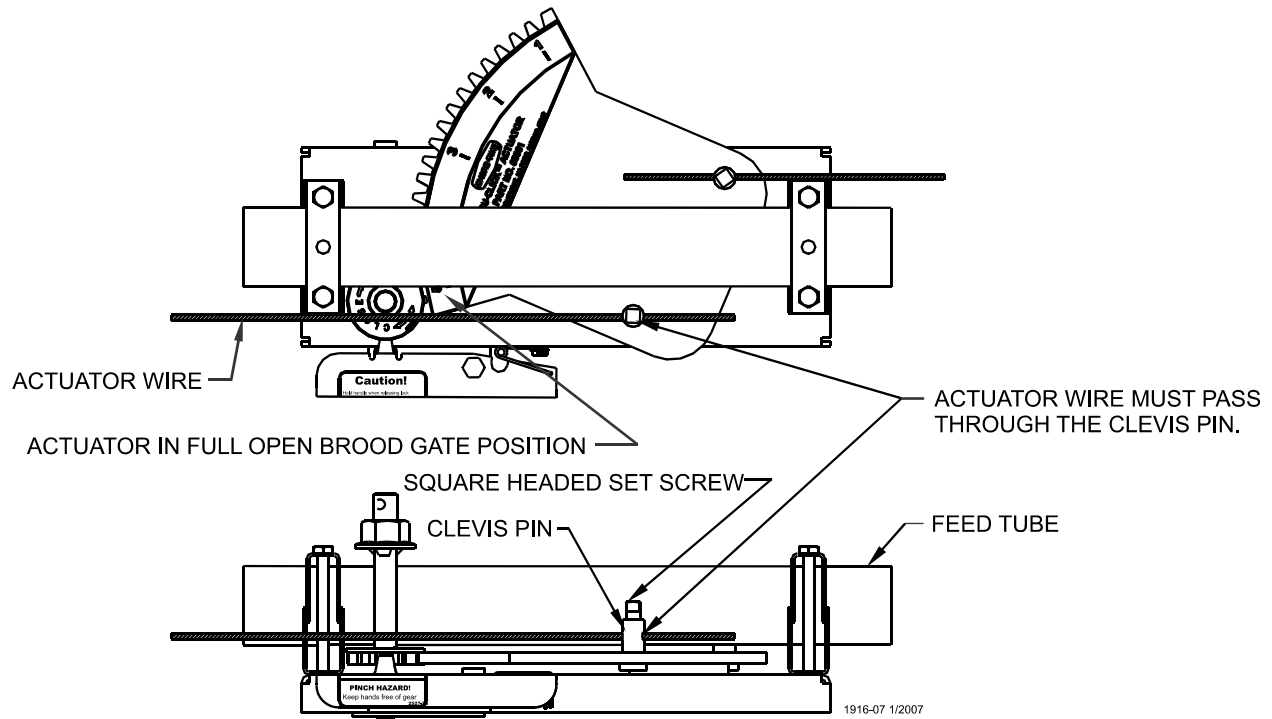

Figure 45. Actuator Wire at ACCU-CLICK™ Actuator.

5. At the terminal spring bracket end; pull any slack in the actuator wire out from the actuator end, which was clamped in the previous step.
6. Clamp with pliers once slack has been removed from the actuator wire, see **figure 46**.

Important! Hold both ends of the actuator wire when cutting.

7. Cut the actuator wire allowing approximately 12" of excess wire past the spring bracket.
8. Stretch both of the springs to 14" [35.6 cm].
9. Clamp the springs to the actuator wire using an 1/8 inch cable clamp, see **figure 46**. Repeat procedure for the remaining actuator wire installation,

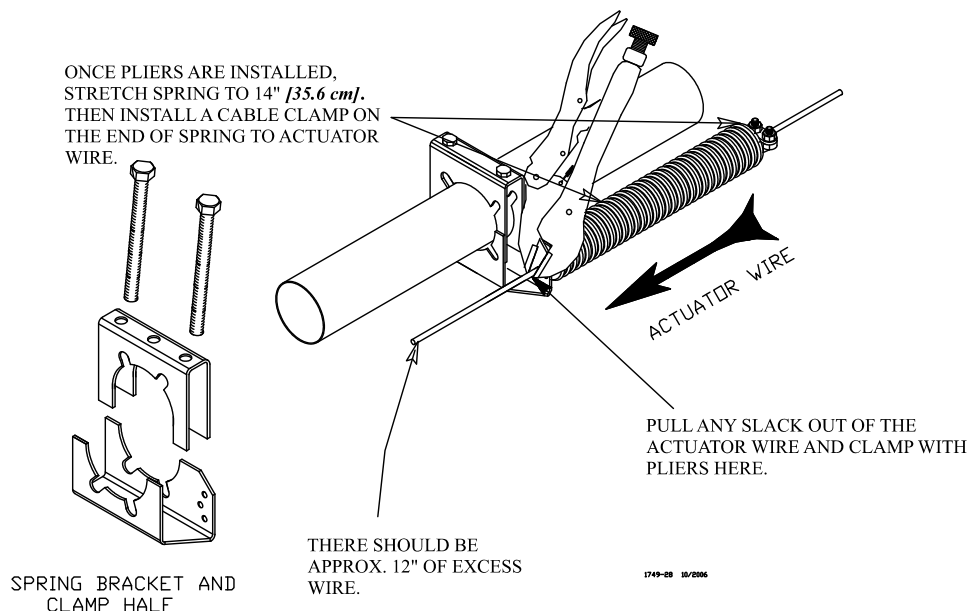

Figure 46. Terminal Bracket

Setting ACCU-CLICK™ Actuator

1. Once all actuators are installed operate actuators to the fully open brood position, see figure .
 - To set actuator in the fully open brood position turn the actuator handle counterclockwise until the actuator stops.

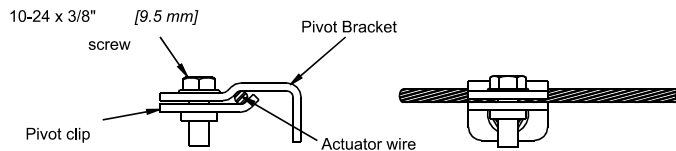

Figure 47. Clamping to actuator wire

2. Using the first pan away from the actuator, push the inner cone to the open position. Place the actuator wire between the pivot bracket and pivot clip then tighten the 10-24 screw, see figure 47.
3. After the 10-24 screw has been tightened operate the actuator open and closed to check operation.
- 4.
5. With the actuator in the open position and the brood gate open tighten the 10-24 screw for each pan.
6. With the brood in the open position. Go to the control unit or hopper end to trim the extra actuator wire. Leave 3 inches [7.6 cm] of excess wire past the spring bracket, see figure 48.
7. Repeat for all remaining actuators.

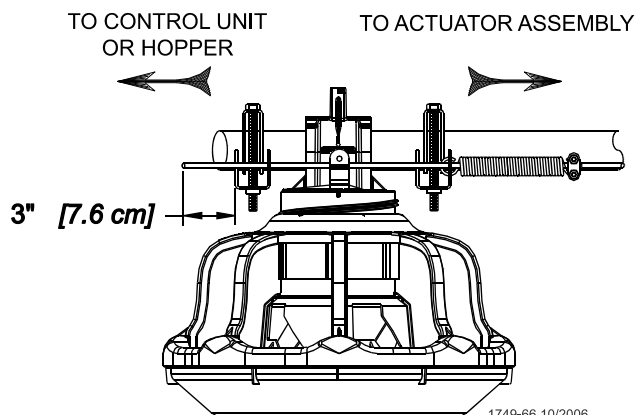

Figure 48. Trim excess actuator wire at control/hopper

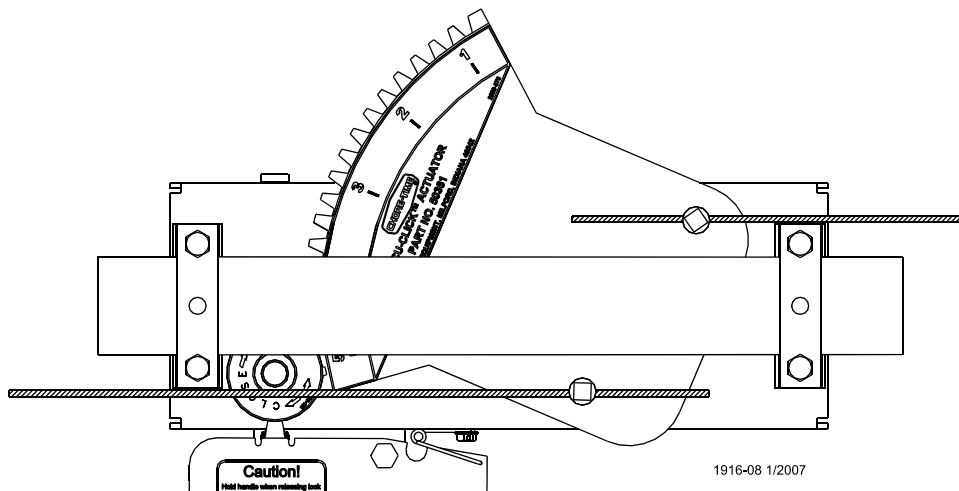

Figure 49. Actuator in Fully Open Brood Position

“End Control and Boot Assembly Installation” on page 43.

Feeder Pan Assembly (Indexing System)

All feeders assemble in the same manor. Refer to **Figure 51 and 52**. The inner cone must turn freely. Align the threads on the outside of the adjustment cone and the grill cap. Turn the cone assembly into the grill cap. Continue turning grill until the pointer lines up with the #2 position. See **Figure 51**. Turn the grill and cone assembly over place the feeder pan on the grill, turn the pan clockwise until the lock engages. Assemble the remaining Feeders. Assembly Box Construction for REVOLUTION 8 Feeders.

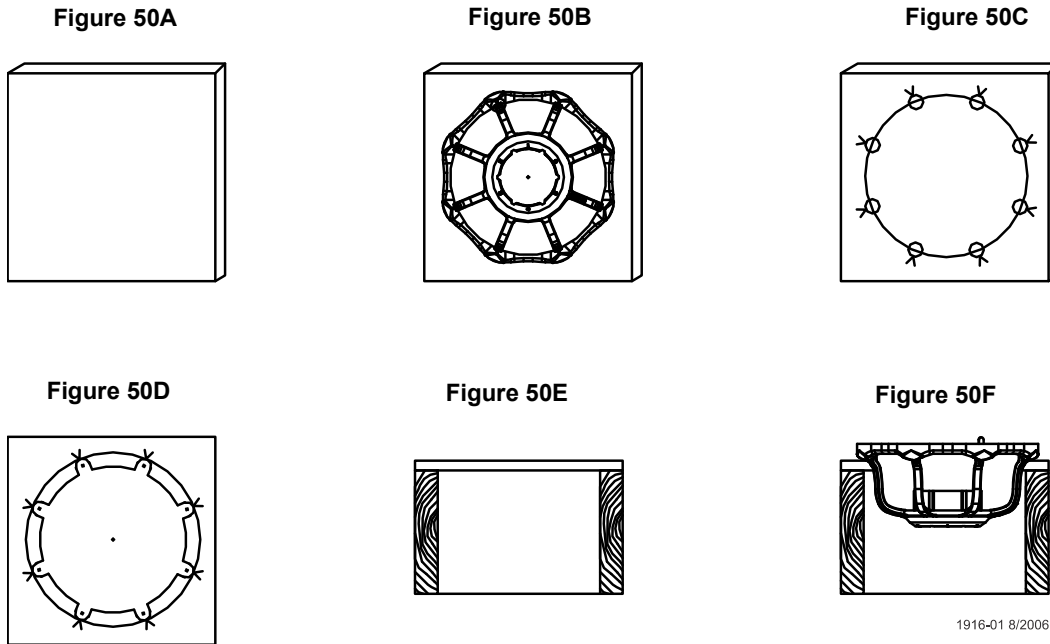

Figure 50. Assembly Box Construction

This information and assembly only applies to REVOLUTION 8 feeder installations.

Chore-Time recommends building an assembly box to aid in assembling the REVOLUTION 8 feeders for pan assembly procedure option 1(see next page).

To build the assembly box use a 16" [406 mm] x 17" [432 mm] piece of plywood and two 14-1/2" and two 17" [432 mm] long pieces of 2" [51 mm] x 12" [305 mm].

1. Cut a piece of 3/4" [19 mm] plywood 16" [406 mm] X 17" [432 mm]. See **Figure 50A**.
2. Center the grill on the 16" [406 mm] X 17" [406mm] piece of plywood. Use a pencil and draw around the inside edge of the grill as shown in **Figure 50B**.
Mark a "V" at each strut location.
3. Remove the grill.
Use a 7/8" [22 mm] spade bit to drill a hole at each strut location, as shown in **Figure 50C**.
4. Use a sabre saw to cut along the *inside* circle, between the 7/8" [22 mm] holes. See **Figure 50D**.
5. Use (2) 14-1/2" [368 mm] and (2) 17" [432 mm] 2 [51 mm] x 12's [305 mm] to construct the box sides. Nail the 3/4" [19 mm] plywood fixture to the box. See **Figure 50E**.
It is important to use at least 12" [305 mm] sides for the box. Smaller lumber will not allow sufficient depth for the grill to be placed in the box face down.

Figure 50F shows how the grill should fit down in assembly box. NOTE: Board is cut away for clarity only.

Pan Assembly Procedure for REVOLUTION 8 Feeders (Option 1)

1. Place a Grill in the pan assembly box fixture.
2. Install cone in the grill, **Check fit, correct, grill and cone should be snug, incorrect if grill and cone have free motion.**
3. Place the feed pan in the grill ring, The pan must be fully seated in the grill then rotate the pan until the pan locks in their grill

Align the threads on the support cone and the grill Cap

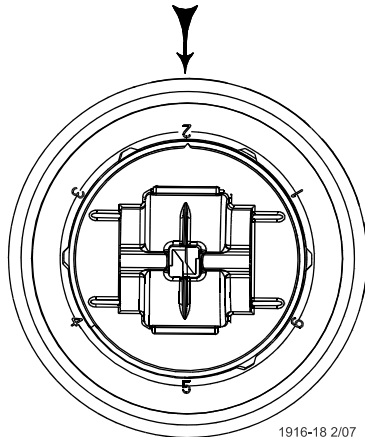

Adjustment of feed level to #2 position.

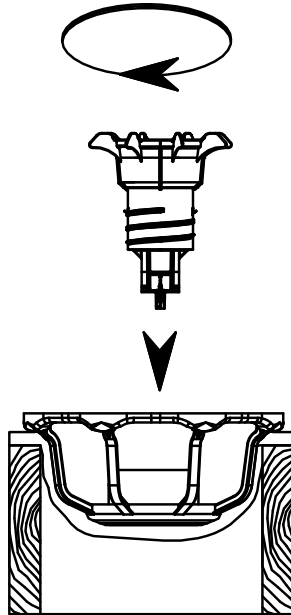

1916-17 2/2007

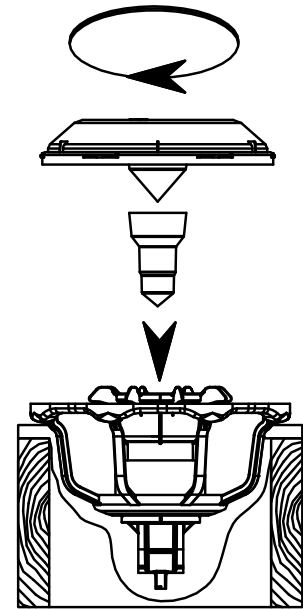

Figure 51. Pan Assembly Option 1

Pan Assembly Procedure for REVOLUTION 8 Feeders (Option 2)

1. Place cone assembly on a flat surface.
2. Set grill over the cone.
3. Rotate the grill until the threads are started.
4. Continue rotating the grill until you reach position # 2.
5. Turn the assembly over then install the pan by rotating the pan until it latches.

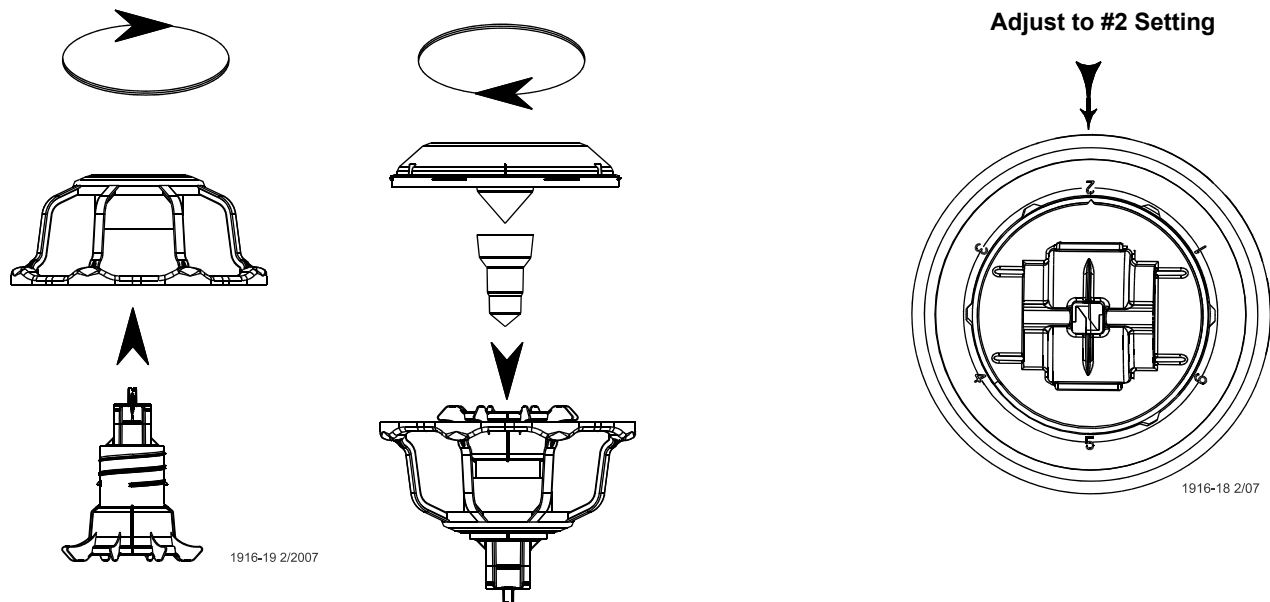

Figure 52. Pan assembly option 2

Feeder Line Assembly & Suspension (Indexing System)

Feeder Pan and Tube Assembly Process

1. Slide one Feeder Pan Assembly per hole onto the Auger Tubes.
IMPORTANT: Install all the feeders on the tubes in the same orientation.
When sliding the feeders on the tubes, make sure the grill openings or hinges are on the same side of the tube.
2. **IMPORTANT: Tube closure kits will need to be installed on the auger tubes at each hole a feeder pan assembly is not installed.**
3. Rotate the auger tubes so that the seam is down, this holds the Pan Assemblies in place, see figure 1.

Assemble and Suspend the Feeder Line

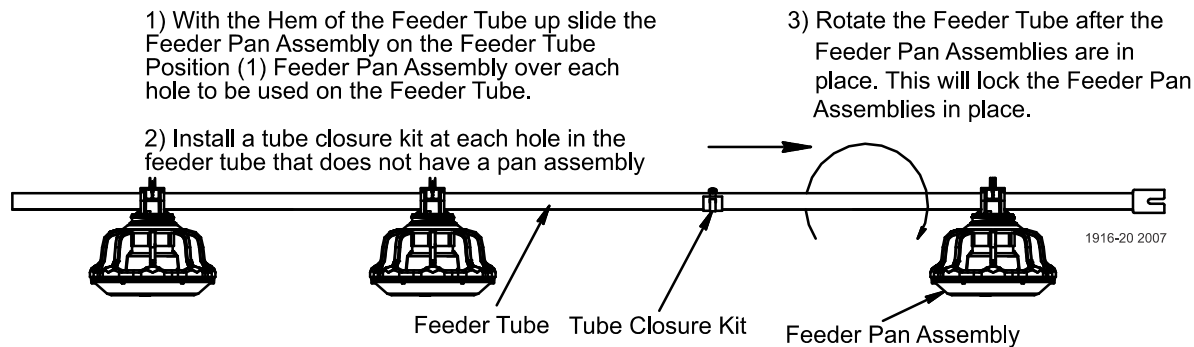

Figure 53. Assemble Feeders on Tubes

1. The auger tubes and feeders may be laid out end to end in approximately the final location of the line. **The expanded end of each tube should be toward the Hopper end of the line, see figure 3.**
2. Connect the individual feeder tubes together by inserting the straight end of one tube as far as possible into the belled end of the next tube. Use suspension drop lines and Hangers to support the tubes as they are being installed. Make sure the tubes are level.

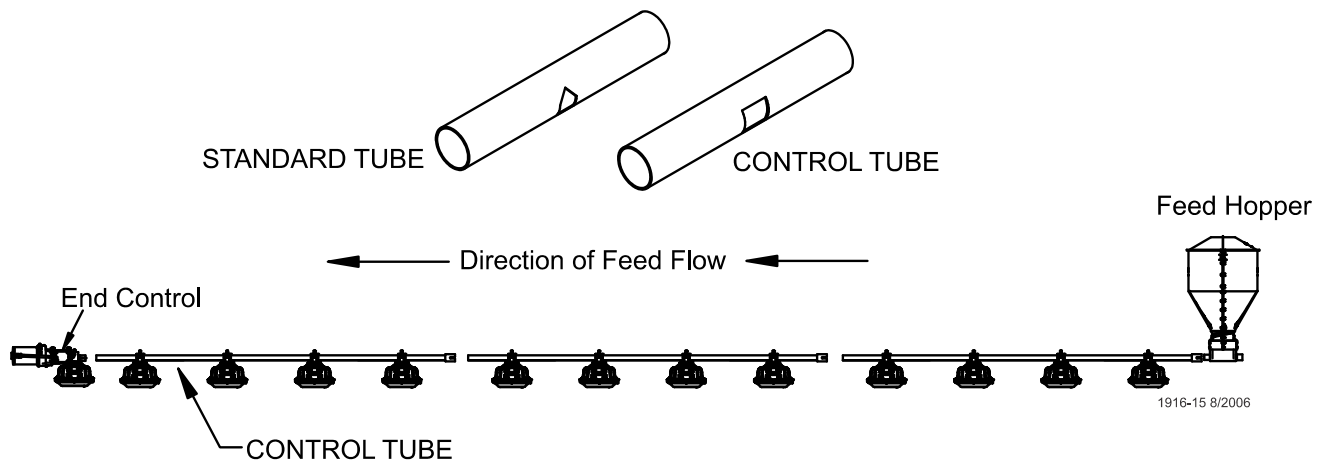

Figure 54. Assemble Feeders on Tubes

3. Use a marker to number the Auger Tubes, beginning at the Hopper. The first Auger Tube at the hopper end of the feeder line would be 1, the second Auger Tube would be 2, etc. Mark each Auger Tube between the hopper and the Control Unit.
4. Place a Tube Clamp Assembly or Clamp/Anti-Roost Bracket at each joint. **Figure 55** shows the standard Clamp and Clamp/Anti-Roost Bracket.
Systems using 9' Auger Tubes require a Clamp/Anti-Roost Bracket at every **fifth** joint.
Systems using 12' tubes require a Clamp/Anti-Roost Bracket at every **fourth** joint. All other joints in the system use the standard Tube Clamp Assembly.

Continue down the feeder line until each tube joint has a standard Tube Clamp or Clamp/ Anti-Roost Bracket. Do not tighten at this time.

5. The Adjustable Hanger is used to hang the feeder line. It is also used to index the feeder line.

Make sure the Adjustable Hanger is facing the proper direction, as specified in **Figure 56**. Refer to the appropriate Indexing Chart on page **page 40** or **page 41** of this manual (depending on whether your Auger Tubes are 9' or 12' long) to program the Auger Tubes. The hanger settings are different for 9' and 12' Auger Tube. However, the settings will work for both mash or crumbles feed.

Find the heading for the number of tubes in your feeder line in the horizontal line at the top of the Indexing Chart. The correct hanger adjustments for each feeder tube are shown in the column under the heading.

Setting Example: If the appropriate setting for the #7 Auger Tube is D5, the "S" Hook should be installed in the #5 hole in the Hanger. The Auger Tube Seam should be in the "D" position, see **figure 57**.

Program each Auger Tube in the feeder line according to the Indexing Chart. Some Auger Tubes may have (2) Hangers, since suspension drop lines are 8' (2.4 m) apart. Both Hangers should be indexed to the same setting.

6. Install Adjustment Leveler within 6" (152 mm) of feeder line. **Figure 58** shows the proper cable routing around the Adjustment Leveler.

7. Raise the feeder line to a convenient working height.

8. With all the Adjustable Hangers in their appropriate settings, the Auger Tubes are ready to be fine tuned.

Begin at the hopper end of the house. Standing down the feeder line looking toward the hopper, the Indexing Gauge should be positioned between the second and third hole in the first Auger Tube with the notch over the tube seam. The Indexing Gauge must be on the right-hand side of the feeder line, see **figure 59**.

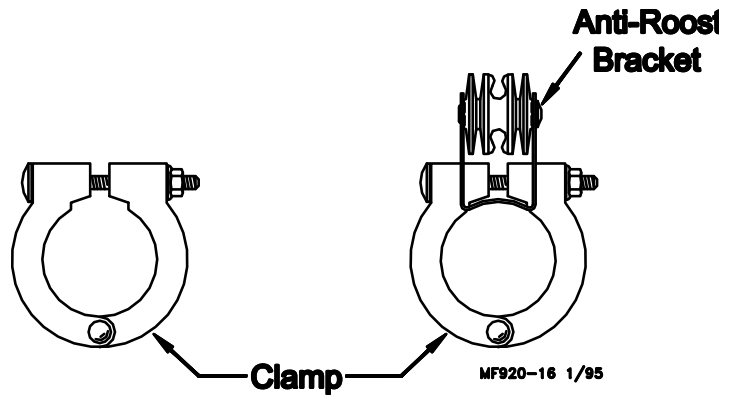

Figure 55. Tube Clamps

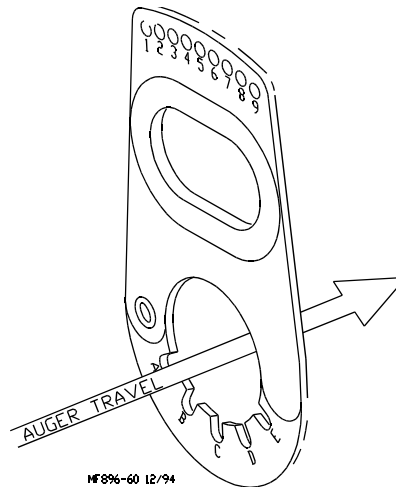

Figure 56. Adjustable Hanger Orientation Diagram

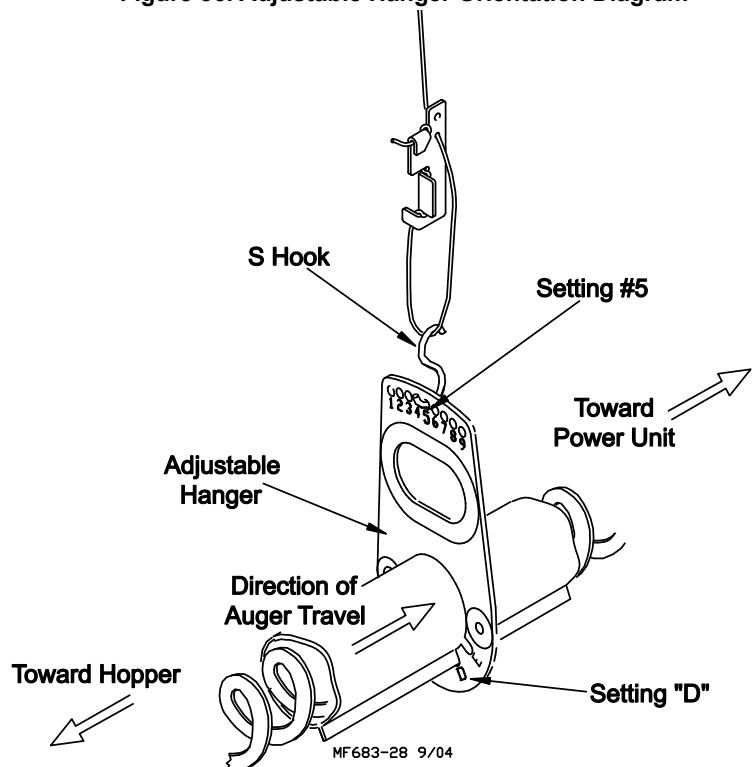

Figure 57. Indexing the Feeder Line

Set the clear pointer on the gauge to the proper setting according to the Indexing Chart.

Rotate the Auger Tube until the bubble in the leveler comes to the center. Tighten the clamp on the bell toward the hopper.

Note: If the tube must be rotated so much that the Adjustable Hangers are tilted too far to one side or the other, check the following;

- Make sure the Adjustable Hanger is set according to the Indexing Chart.
- Make sure the Indexing Gauge is set correctly according to the tube number and Indexing Chart.
- Make sure Indexing Gauge is placed on the tube correctly.
- Make sure that you are referring to the appropriate Indexing Chart for the length of Auger Tubes being indexed.

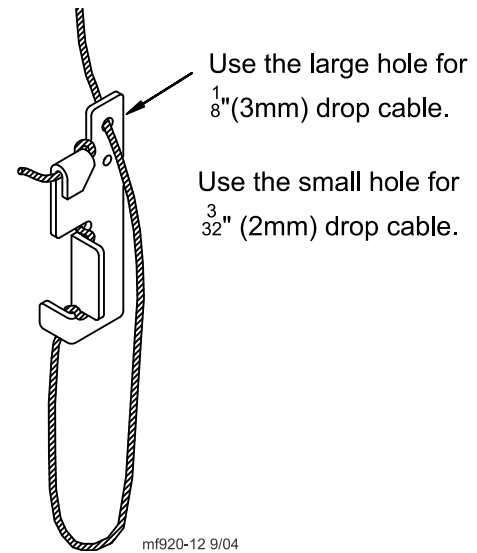

Figure 58. Adjustment Leveler Installation

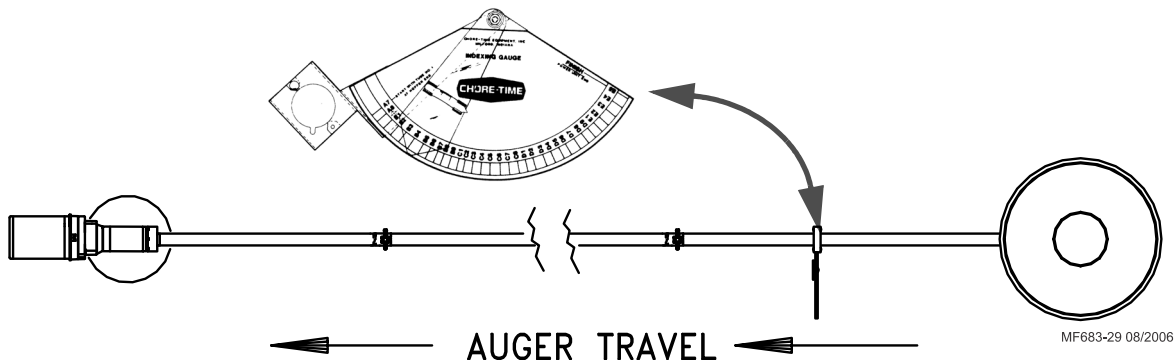

Figure 59. Indexing the Feeder Line

9. Continue to set each Auger Tube in the feeder line. After each tube is set, tighten the clamp on the bell end toward the hopper. The clamps should be positioned as shown in Figure 60. Do not crush the tubes by overtightening the clamps.

Be careful not to accidentally move the tube already set. This may require an extra person to hold the end of the tube just set, while you fine tune the next tube.

Be careful not to deform the tubes with wrenches or large adjustable pliers.

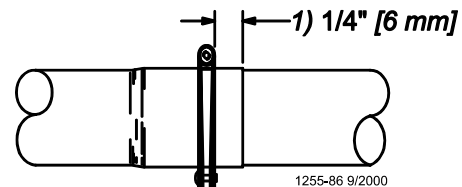

Figure 60. Tube Clamp Location

Indexing the Feeder

- Beginning at the hopper, use a marker to number the feeder tubes. Begin with tube #1 at the hopper, then #2, #3, and do on, continuing until each tube in the line is marked.
- Loosen the tube clamps, or if a new house, leave the tube clamps loose, until the line has been indexed.
- Use the Proper Indexing Chart for the tube that is being indexed. The indexing starts are based on the tube length. Find the heading for the number of tubes in your system in the horizontal line at the top of the indexing chart. The correct hanger adjustments for each feeder tube are shown in the column under the heading.
- After all Hanger Assemblies have been installed, use the Indexing Gauge to accurately set and adjust the feeder line.
- Start at the hopper end of the house. Standing down the feed line looking back at the hopper, the Indexing Gauge should be placed with the notch over the crimped portion of the tube with the gauge on the right side

of auger tube, The Index gauge should be placed between the second and third hole on tube #1, see figure 61.

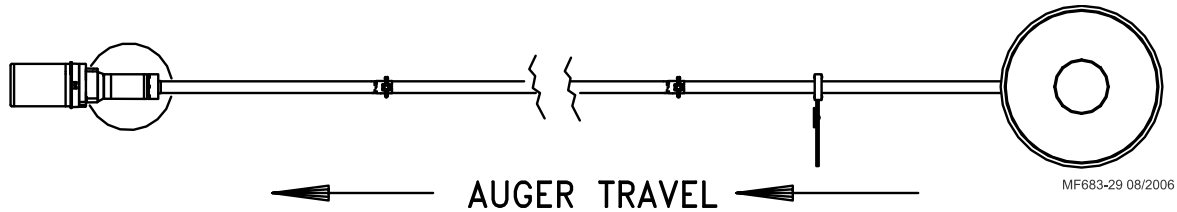

Figure 61. Indexing the feeder line

6. Set the clear pointer on the gauge to the proper setting according to the indexing chart. Rotate the tube until the bubble in the leveler comes to the center. Tighten the clamp on the bell toward the hopper.

Note: If the tube must be rotated so much that the Hanger Assembly is tilted too far to one side or the other, check the following:

- Make sure the Hanger Assembly is set according to the appropriate Indexing Chart.
- Make sure the Indexing Gauge is set correctly according to the Indexing Chart.
- Make sure the Indexing Gauge is placed on the tube correctly.
- Make sure that the settings for both the Indexing Gauge and the adjustable hangers are taken from the correct chart for length of auger tube being indexed.

7. Index each of the remaining tubes in the same manner. After each tube has been set, tighten the clamp on the bell end toward the hopper. Position the clamps on the tube joints, as shown in Figure 60.

Note: Use two large adjustable pliers or pipe wrenches to grip the tube; being careful not to deform the tubes.

Make sure the tubes already set do not move. (This will require a second person to hold the end of the tube that has just been set while you turn the next tube to be set.)

8. Close both ends of the “S” Hook between the cable and Hanger.

Indexing Chart for Male Feeders

For Systems using 9' (2.7 m) Auger Tube and 348 RPM Power Units

		Number of Tubes																	
		31	30	29	28	27	26	25	24	23	22	21	20	19	18	17	16		
Tube Number	1	B4	B4	B4	B4	B4	B5	B5	B5	B5	B6	B6	B6	B7	B7	B7	B7	1	1
	2	B5	B5	B5	B5	B5	B6	B6	B6	B6	B7	B7	B7	B8	B8	B8	B8	2	2
	3	B6	B6	B6	B6	B6	B7	B7	B7	B7	B8	B8	B8	B9	B9	B9	B9	3	3
	4	B7	B7	B7	B7	B7	B8	B8	B8	B8	B9	B9	B9	C1	C1	C1	C1	4	4
	5	B8	B8	B8	B8	B8	B9	B9	B9	B9	C1	C1	C1	C2	C2	C2	C2	5	5
	6	B8	B9	B9	B9	B9	C1	C1	C1	C1	C2	C2	C2	C3	C3	C3	C3	6	6
	7	B9	B9	C1	C1	C1	C2	C2	C2	C2	C3	C3	C3	C4	C4	C4	C5	7	7
	8	B9	C1	C1	C1	C2	C2	C3	C3	C3	C4	C4	C4	C4	C4	C5	C6	8	8
	9	C1	C1	C2	C2	C2	C3	C3	C3	C4	C4	C4	C4	C5	C6	C7	C8	9	9
	10	C1	C2	C2	C2	C3	C3	C4	C4	C4	C5	C5	C5	C6	C7	C8	D1	10	10
	11	C2	C2	C3	C3	C3	C4	C4	C4	C5	C5	C5	C6	C7	C8	D1	D2	11	11
	12	C2	C3	C3	C3	C4	C4	C5	C5	C5	C6	C6	C7	C8	D1	D2	D3	12	12
	13	C3	C3	C4	C4	C4	C5	C5	C5	C6	C6	C7	C8	D1	D2	D3	D5	13	13
	14	C3	C4	C4	C4	C5	C5	C6	C6	C6	C7	C8	D1	D2	D3	D5	D7	14	14
	15	C4	C4	C5	C5	C5	C6	C6	C6	C7	C8	D1	D2	D3	D5	D7	E2	15	15
	16	C4	C5	C5	C6	C6	C6	C7	C7	C7	D1	D2	D3	D5	D7	E2	E3	16	16
	17	C5	C5	C6	C6	C6	C7	C7	C8	C8	D2	D3	D5	D7	E2	E3		17	17
	18	C5	C6	C6	C7	C7	C7	C8	D1	D1	D3	D5	D7	E2	E3			18	18
	19	C6	C6	C7	C7	C7	C8	D1	D2	D2	D5	D7	E2	E3				19	19
	20	C6	C7	C7	C8	C8	D1	D2	D3	D5	D7	E2	E3					20	20
	21	C7	C7	C8	C8	D1	D2	D3	D5	D7	E2	E3						21	21
	22	C7	C8	C8	D1	D2	D3	D5	D7	E2	E3							22	22
	23	C8	C8	D1	D2	D3	D5	D7	E2	E3								23	23
	24	C8	D1	D2	D3	D5	D7	E2	E3									24	24
	25	D1	D2	D3	D5	D7	E2	E3										25	25
	26	D2	D3	D5	D7	E2	E3											26	26
	27	D3	D5	D7	E2	E3												27	27
	28	D5	D7	E2	E3													28	28
	29	D7	E2	E3														29	29
	30	E2	E3															30	30
	31	E3																31	31

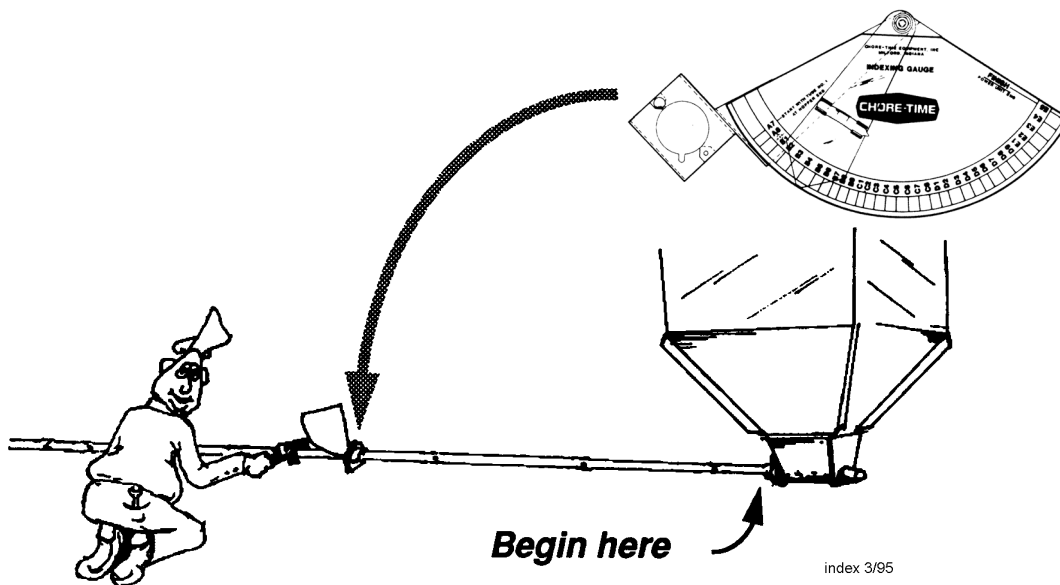

index 3/95

For Systems using 10' (3 m) or 12' (3.6m) Auger Tube and 696 RPM Power Units

		Number of Tubes																	
		31	30	29	28	27	26	25	24	23	22	21	20	19	18	17	16		
Tube Number	1	B5	B5	B5	B6	B6	B6	B7	B7	B7	B8	B8	B8	B8	B9	B9	B9	1	
	2	B6	B6	B6	B7	B7	B7	B8	B8	B8	B9	B9	B9	B9	C1	C1	C1	2	
	3	B7	B7	B7	B8	B8	B8	B9	B9	B9	C1	C1	C1	C1	C2	C2	C2	3	
	4	B7	B8	B8	B9	B9	B9	C1	C1	C1	C2	C2	C2	C2	C3	C3	C3	4	
	5	B8	B8	B9	B9	C1	C1	C1	C1	C2	C2	C2	C3	C3	C4	C4	C4	5	
	6	B8	B9	B9	C1	C1	C1	C2	C2	C2	C3	C3	C3	C4	C4	C5	C5	6	
	7	B9	B9	C1	C1	C2	C2	C2	C2	C3	C3	C3	C4	C4	C5	C5	C6	7	
	8	B9	C1	C1	C2	C2	C2	C3	C3	C3	C4	C4	C4	C5	C5	C6	C7	8	
	9	C1	C1	C2	C2	C3	C3	C3	C3	C4	C4	C4	C5	C5	C6	C7	C8	9	
	10	C1	C2	C2	C3	C3	C3	C4	C4	C4	C5	C5	C5	C6	C7	C8	D1	10	
	11	C2	C2	C3	C3	C4	C4	C4	C4	C5	C5	C5	C6	C7	C8	D1	D2	11	
	12	C2	C3	C3	C4	C4	C4	C5	C5	C5	C6	C6	C7	C8	D1	D2	D3	12	
	13	C3	C3	C4	C4	C5	C5	C5	C5	C6	C6	C7	C8	D1	D2	D3	D5	13	
	14	C3	C4	C4	C5	C5	C5	C6	C6	C6	C7	C8	D1	D2	D3	D5	D7	14	
	15	C4	C4	C5	C5	C6	C6	C6	C6	C7	C8	D1	D2	D3	D5	D7	E2	15	
	16	C4	C5	C5	C6	C6	C6	C7	C7	C7	D1	D2	D3	D5	D7	E2	E3	16	
	17	C5	C5	C6	C6	C7	C7	C7	C8	C8	D2	D3	D5	D7	E2	E3		17	
	18	C5	C6	C6	C7	C7	C7	C8	D1	D1	D3	D5	D7	E2	E3			18	
	19	C6	C6	C7	C7	C8	C8	D1	D2	D2	D5	D7	E2	E3				19	
	20	C6	C7	C7	C8	C8	D1	D2	D3	D5	D7	E2	E3					20	
	21	C7	C7	C8	C8	D1	D2	D3	D5	D7	E2	E3						21	
	22	C7	C8	C8	D1	D2	D3	D5	D7	E2	E3							22	
	23	C8	C8	D1	D2	D3	D5	D7	E2	E3								23	
	24	C8	D1	D2	D3	D5	D7	E2	E3									24	
	25	D1	D2	D3	D5	D7	E2	E3										25	
	26	D2	D3	D5	D7	E2	E3											26	
	27	D3	D5	D7	E2	E3												27	
	28	D5	D7	E2	E3													28	
	29	D7	E2	E3														29	
	30	E2	E3															30	
	31	E3																31	

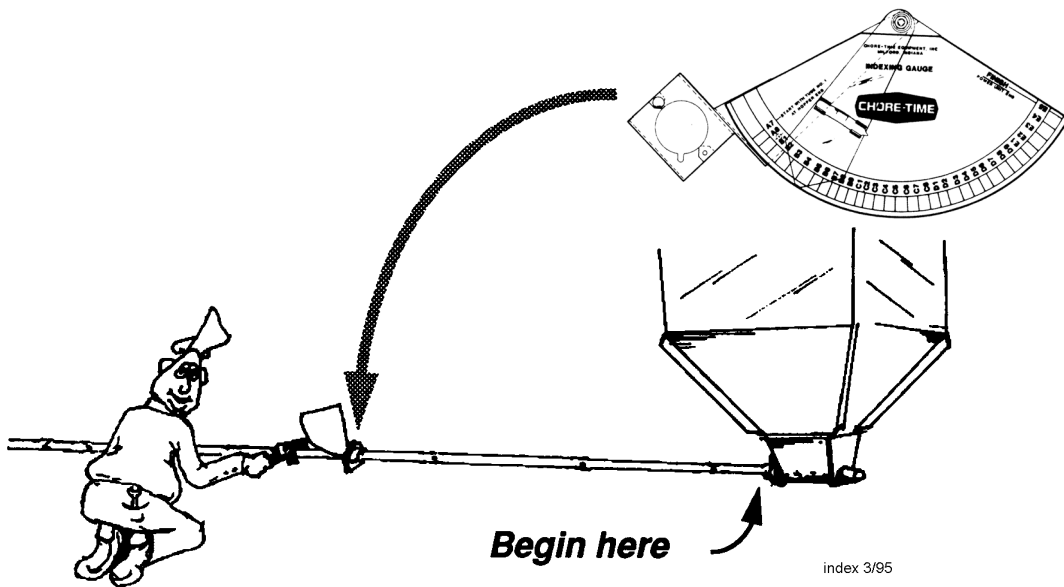

index 3/95

Anti-Swing Installation

The anti-swing clamps are designed for breeder and rooster operations to prevent the feeders from swinging on the auger tubes.

Note: The seam of auger tube and hardware for the Lock must be on opposite sides as shown. Otherwise an interference will occur.

Install the adjustable clamp around the feeder tube. Slide the locking device into position and secure it in position with the adjustable clamp.

Make sure the feeder is in the upright position before securing the locking device to the auger tube using the adjustable clamp.

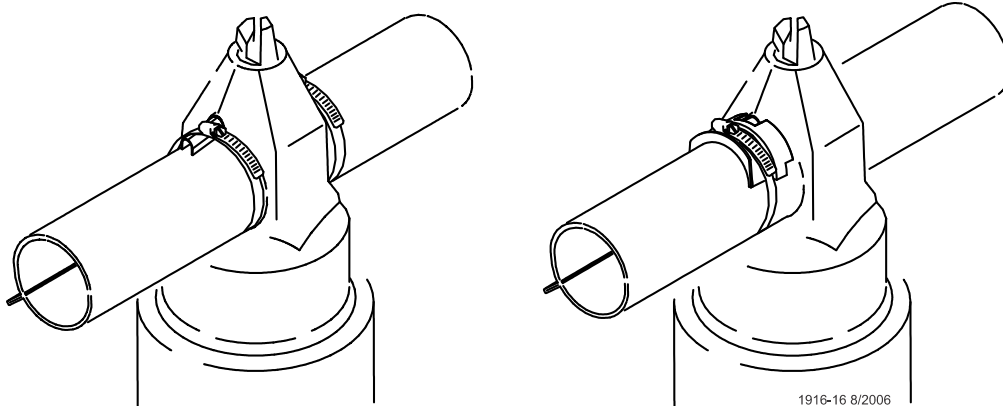

Figure 62. Feeder Anti-Swing Clamp Installation

End Control and Boot Assembly Installation

The End Control Unit must be at least 10 feet [3 m] from the end of the building to allow birds access around the end of the feeder line.

1. Assemble the End Control Unit to the Feeder Line Control Tube using a clamp/anti-roost bracket. See **Figure 63. DO NOT INSTALL THE POWER UNIT AT THIS TIME.**

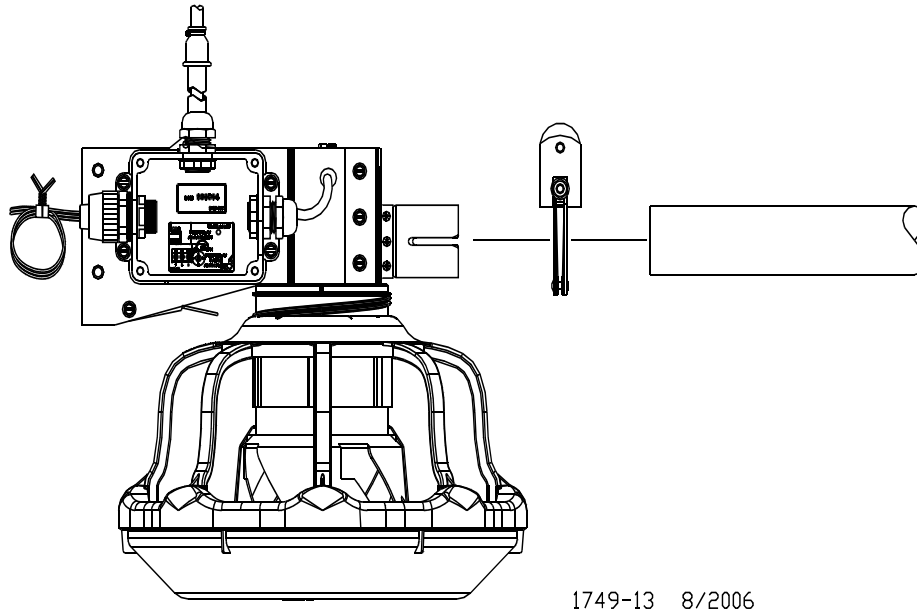

Figure 63. Connecting End Control Unit to the Feed Line Tube

2. Install the Feeder Boot by sliding the straight end of the Feeder Boot into the belled end of the Feeder Tube. Install a clamp/anti-roost bracket on the bell and tighten. The Feeder Boot must be level with the feeder line and the open top of the Feeder Boot must be horizontal. See **Figure 64. DO NOT INSTALL THE ANCHOR BEARING AND BEARING RETAINER AT THIS TIME.**

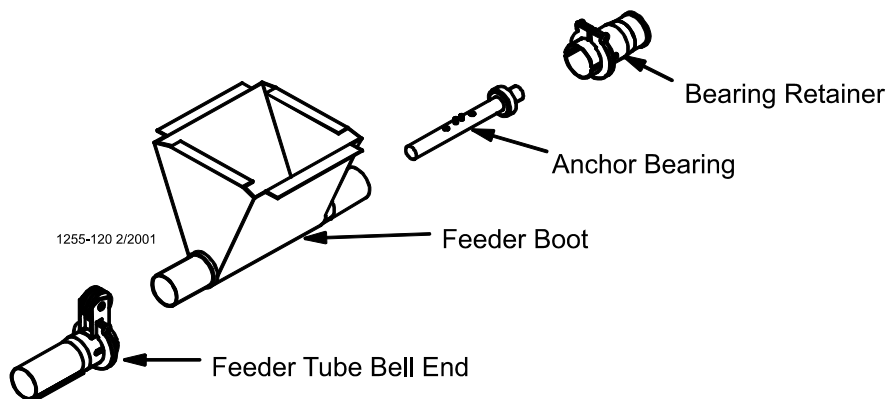
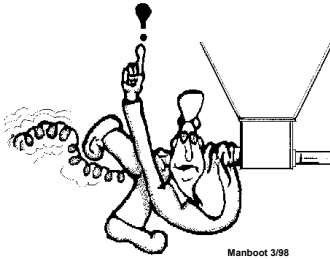

Figure 64. Installing the Feeder Boot

Auger Installation

Note: Use extreme caution when working with the auger. The auger is under tension and may spring causing personal injury. Wear protective clothing, gloves, and safety glasses when working with the auger.



**BE CAREFUL WHEN
WORKING WITH THE
AUGER!**

To avoid kinking the auger, be careful not to drop the rolled auger when handling. Inspect the auger carefully as it is installed. Small kinks may be straightened. Large kinks must be removed and the auger brazed back together.

Cut the leading 18" [450 mm] and last 18" [450 mm] off each roll of auger. Also, cut out any other distorted auger sections and reconnect the auger as specified in the Auger Brazing section of this manual.

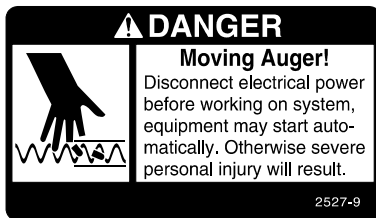

1. Use extreme caution when pushing the auger into the auger tubes. Keep your hand away from the end of the auger tube to avoid injury.
With the auger coiled about 6 feet [1.8 m] from the end of the boot, uncoil the auger from the outside and feed the auger through the boot into the tubes.
Push the auger into the tube in short strokes.
Uncoil and handle the auger carefully to avoid damaging or kinking the auger.
2. If more than one coil is required for each feeder line, the auger ends will have to be brazed together. Refer to the Brazing the Auger section in this manual.
3. Install the Anchor Bracket to the Power Unit/Gearhead, as shown in **Figure 65**, with the included 5/16-18 Bolts.

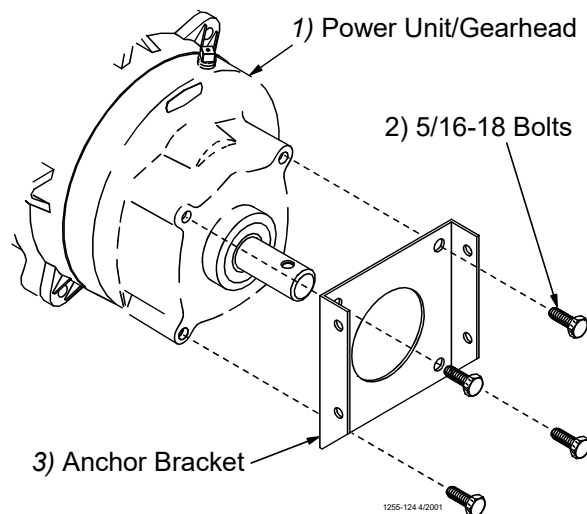

Figure 65. Assemble the Anchor Bracket to the Power Unit/Gearhead

4. Slide the Drive Tube and flat washer over the output shaft on the Power Unit, as shown in **Figure 66**.
5. Continue installing auger until the auger reaches the Control Unit end of the feeder line.

6. Turn the Drive Tube Weldment into the auger, then attach to the output shaft of the Power Unit, as shown in **Figure 66**. Use the Driver Block to secure the auger to the Output Shaft.

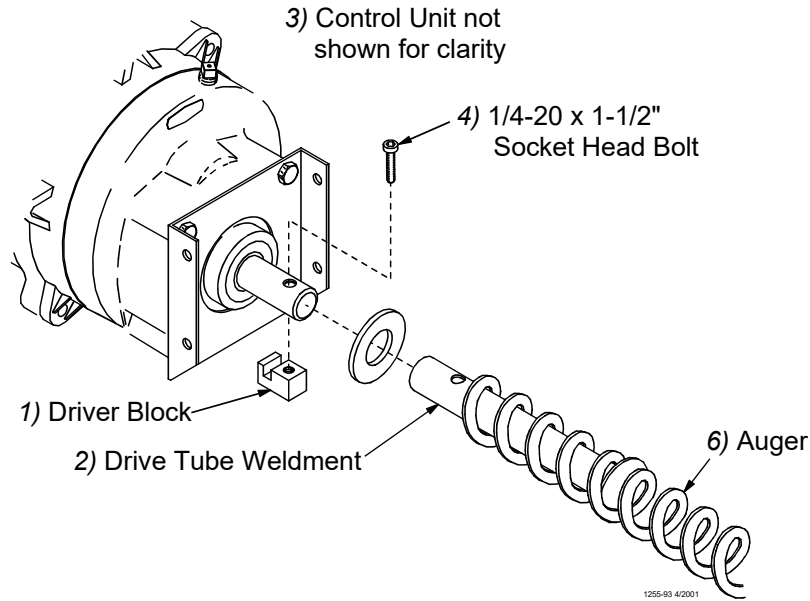

Figure 66. Auger Driver Components

7. Attach the Anchor Plate and Gearhead Assembly to the Control Unit Body using the included 1/4" Lock Washers and 1/4-20 x 1/2" Bolts. See **Figure 67**.

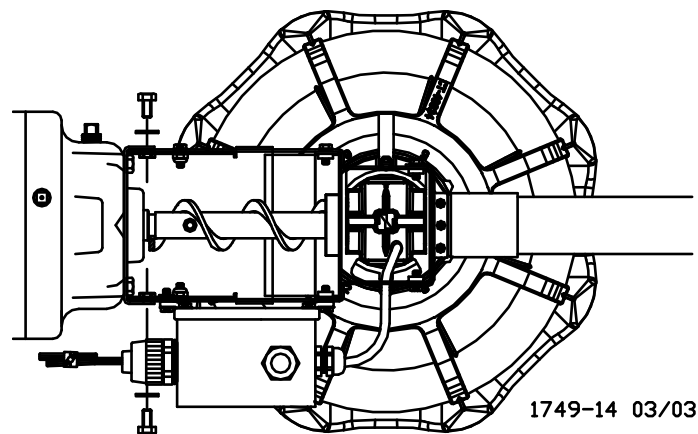

Figure 67. Attaching the Anchor Plate and Gearhead Assembly to the Control Unit Body

8. Install the Metal Water Tight Connector (item 1) in the Feed Line Motor (item 2). Cut the Flex Conduit (item 3) to length. Slide the wires from the end control through the Flex Conduit (item 3). Install the Flex Conduit (item 3) in the connectors. Connect the wires to the Feed Line Motor (item 2) (See Figure 68.)

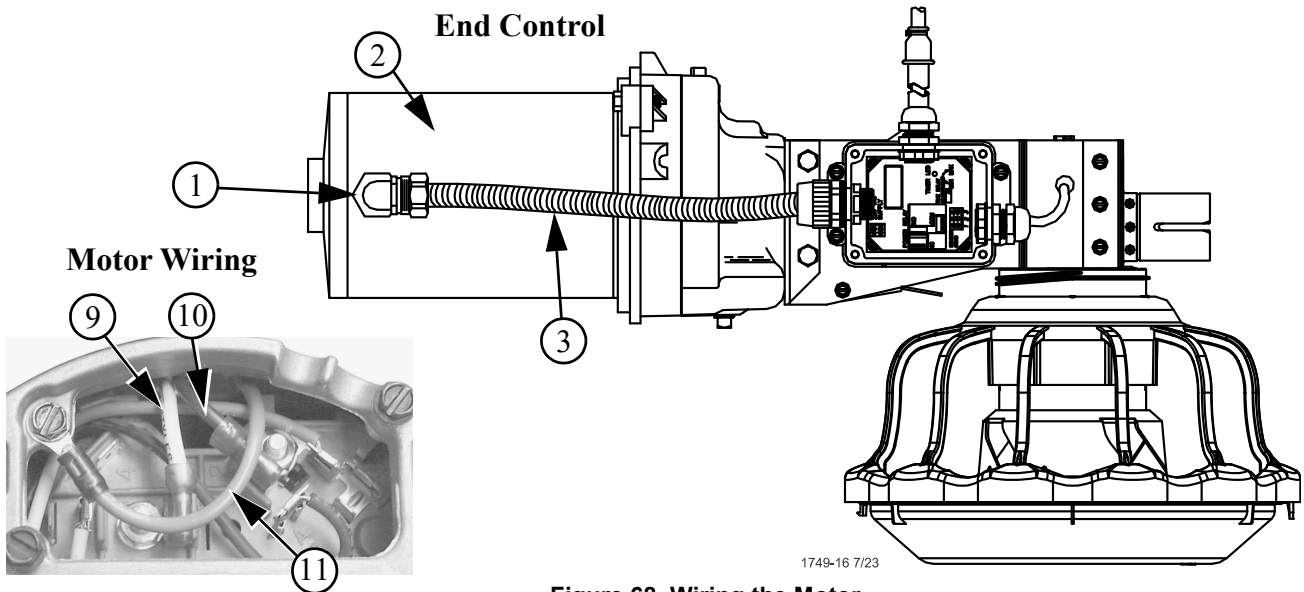

Figure 68. Wiring the Motor

9. Attach all covers and wire according to the wiring section of this manual.

10. Pull the auger at the boot end until it begins stretching. Then let it relax. In the *relaxed* position, mark the auger at the end of the boot. See Figure 11.

11. Auger stretch:

The auger needs to be stretched 7" [180 mm] per 100' [30 m]. Example: A 300' [90 m] feeder line requires 21" [500 mm] of stretch.

Beginning at the *relaxed* position, measure the required amount of stretch. Mark the auger at that point.

Grip the auger 8" [200 mm] ahead of this mark with locking pliers. Allow the auger to pull back into the boot so that the pliers rest against the end of the boot. (See Figure 70.)

Use a hacksaw or bolt cutters to cut the auger at the stretched auger mark.

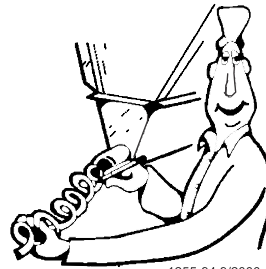

Figure 69. Measure the Auger from the relaxed position

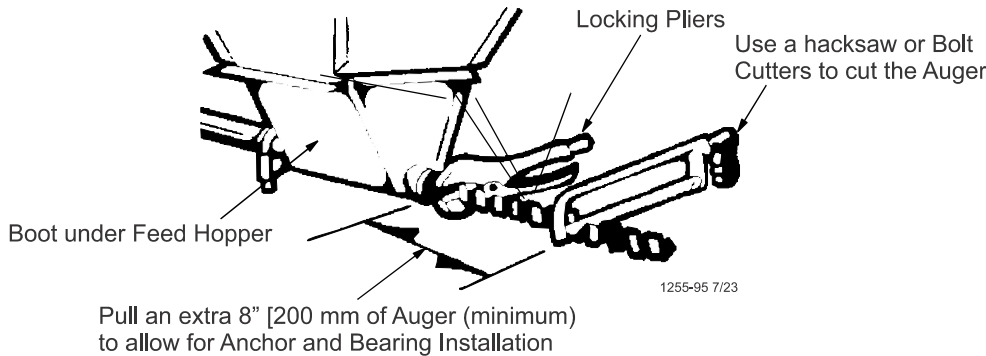

Figure 70. Cut the Auger with required stretch

12. Insert the Anchor Assembly into the auger until it touches the washer at the back of the anchor. Tighten the setscrews in the center of the anchor until they touch the auger, then tighten a maximum of 1/2 turn. See Figure 71.

Figure 71.
DO NOT OVERTIGHTEN THE SET SCREWS.

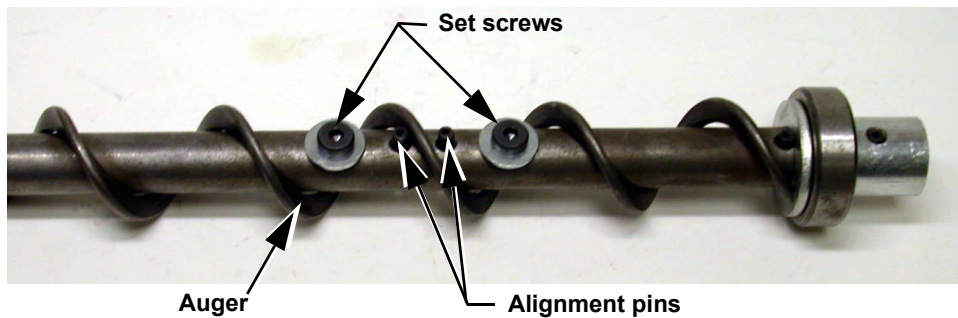
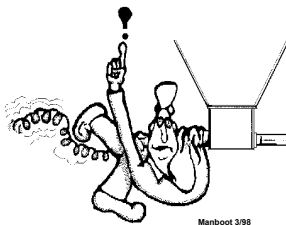

Figure 71. Auger and Anchor Bearing Connection

13. **Carefully** remove the locking pliers while holding onto the Anchor and Bearing Assembly and auger securely.
Slowly ease the auger back into the tube. Use caution. If the auger is allowed to spring back, the bearing race may crack.
 Install the Bearing Retainer and fasten with a tube clamp. Keep the Bearing Retainer flush with the end of the anchor for safety.
14. Place the cannonball in the boot.



BE CAREFUL WHEN WORKING WITH THE AUGER!

Auger Brazing

The auger should be brazed if it is necessary to splice or lengthen it. A bronze, flux coated rod is recommended. The ends of the auger should butt against each other, **DO NOT THREAD INSIDE EACH OTHER.** See Figure 72. The joint should be well filled with no sharp edges or rough corners to wear against the tube. To align the auger for brazing, lay it in angle or channel iron and clamp it firmly in place. Use low heat. Allow the joint to air cool; rapid cooling will cause the auger to become brittle.

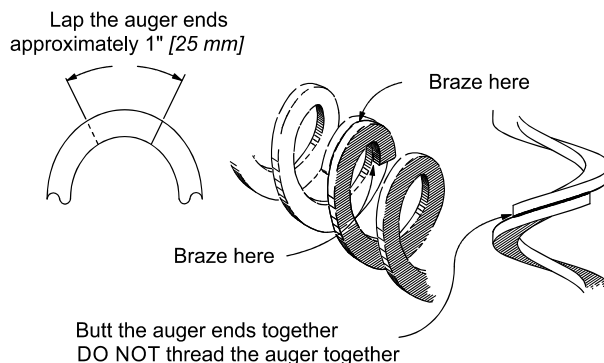

Figure 72. Auger Brazing

Anti-Roost Installation

1. Unroll the bulk anti-roost cable. Note: If the cable is unrolled as shown in **Figure 73**, taking 5 loops of the coil with one hand, then changing hands to remove 5 loops as it is unrolled, it will lie flat during installation.

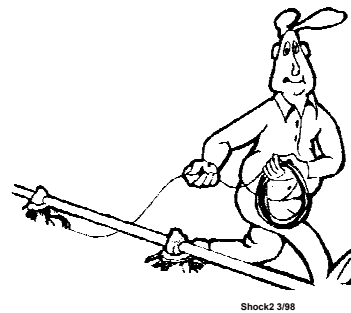

Figure 73. Unrolling the Cable

2. Start at the hopper end of the line and form a loop around the anti-roost bracket. For best results, make a double loop around the anti-roost insulator in the center groove of the insulator and fasten with a 1/16" cable clamp as shown in **Figure 74**.
3. Insert the cable in the insulator on the top of each Grill Support between the hopper and the next anti-roost bracket.
4. Attach a spring in the center groove at the second anti-roost bracket and cut the cable at this point. See **Figure 75**.

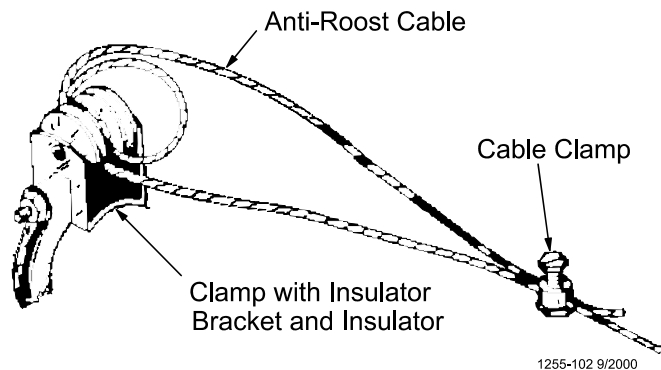

Figure 74. Anti-Roost Cable at the Hopper

5. Thread the ends of the cable through the end of the spring. Pull the cable tight so that there is 3/4" to 1" [20 to 25 mm] of stretch in the spring. Clamp the cable to form a loop and cut off any excess. See **Figure 75**.
6. Attach the cable to the insulator. For best results, make a double loop around the anti-roost insulator in the center groove of the insulator and fasten with a 1/16" cable clamp as shown in **Figure 75**.
7. Run the cable to the next insulator, attach a spring in the center groove at the anti-roost bracket and cut the cable at this point. The cable should be positioned in the insulator built into the top of each grill support along the feeder line.
8. Repeat this installation until the anti-roost cable is installed along the entire feeder line.

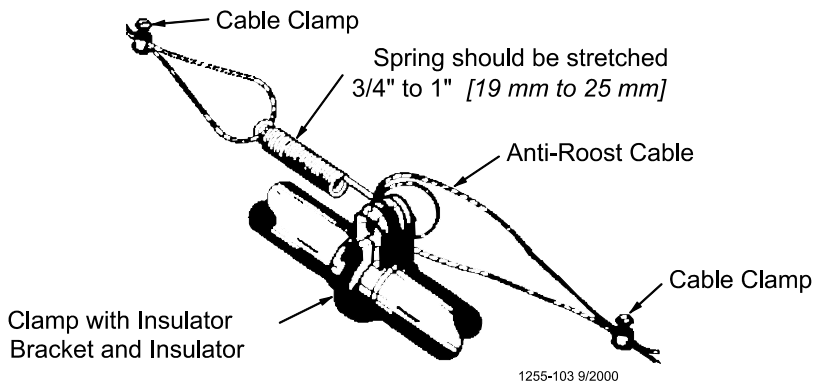

Figure 75. Anti-Roost Cable Mid-Line Connection

9. At the control unit, after clamping the cable to the spring, cut the cable about 8" to 10" [200 to 250 mm] longer than necessary. Feed the end of the cable through the center of the spring, around the first insulator on the control unit, and clamp the cable using the cable clamp supplied with the control unit. See **Figure 77**.
10. Install the wire form on the control unit insulators. Be sure the guard snaps into the retainers molded into the insulators. See **Figure 77**.

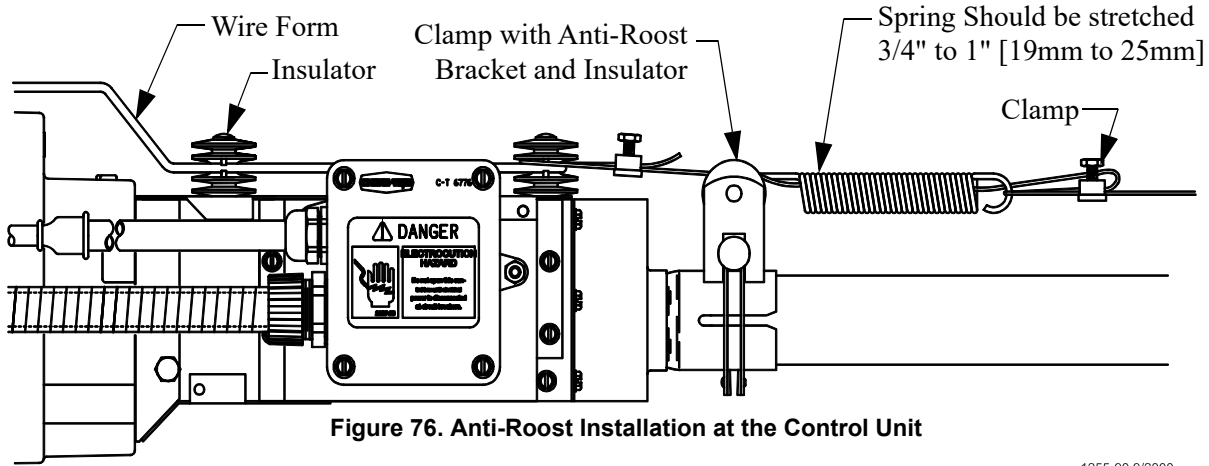

Figure 76. Anti-Roost Installation at the Control Unit

1255-90 9/2000

Figure 77.

11. Install the Poultry Trainer or Line Charger, as shown in **Figure 12**. The Poultry Trainer is used to power all Anti-Roost lines in a house. See **Figure 12**. The Line Charger is used to power individual Anti-Roost lines in a house. See **Figure 12**. Route the charger wire from the Poultry Trainer or Line Charger to the Anti-Roost system. Secure the Charger Wire to the Anti-Roost cable, using a cable clamp.

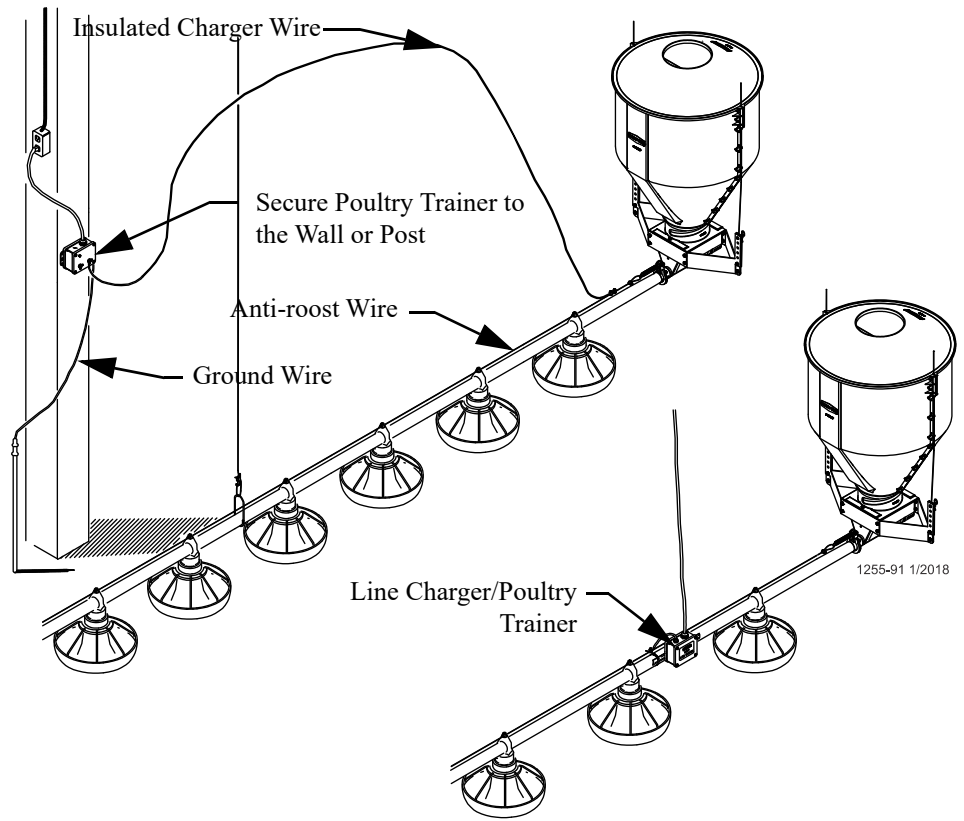

Figure 78. Poultry Trainer Installation

1255-91 1/2018

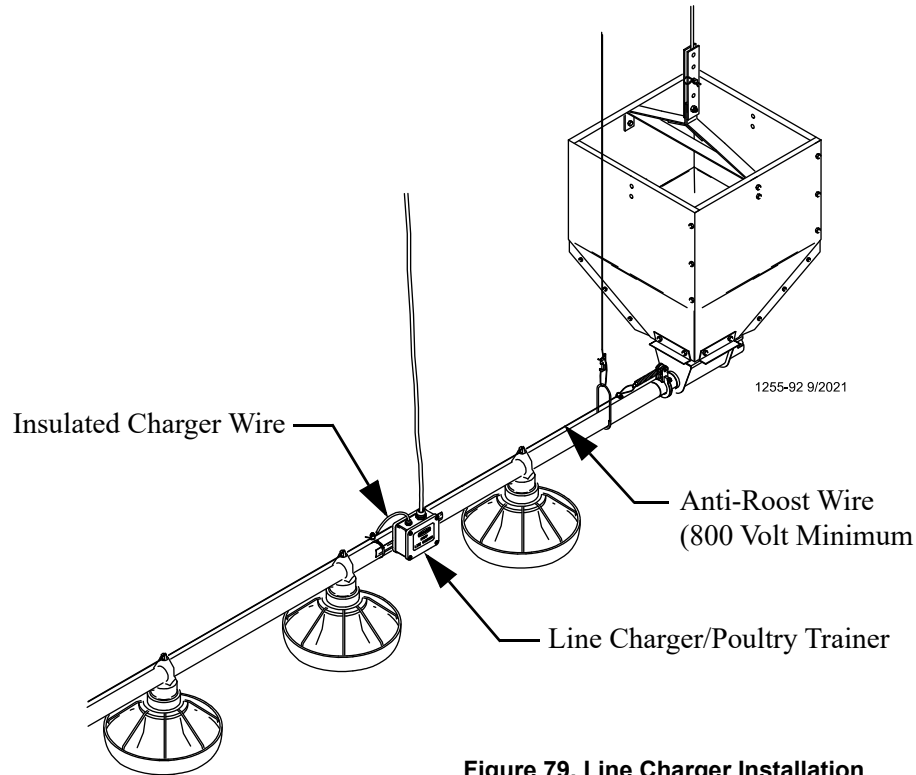

Figure 79. Line Charger Installation

12. The **anti-roost system** *must* be on a **separate electrical circuit**, allowing the system to be disconnected by a switch near the door.
Remember, the anti-roost system should be **grounded through the poultry trainer**.

Electro-guard Operation

The electro-guard chargers should be operated on a separate electrical circuit so the anti-roost system can be shut off using a switch next to the entrance door when someone enters the building. Birds are less likely to become wild and flighty if the anti-roost is off when people are in the building.

Feeder Management and Operation

This section provides you with valuable information concerning feeder operation and management. It is important that you read this information and understand how the feeding system was designed to operate. Once you become familiar with the system, you may *custom operate* it to fit your individual needs.

Initial Start-up of the Feeding System

The Feeding System should be operated prior to birds being housed to make sure the installation is correct, the switches function properly, and to fill the feeder lines with feed.

There are two typical layouts for the feeding system that was determined prior to the installation. Normally if the building is 400' [122 m] or over, a center house hopper set-up is used. See **Figure 80**. For buildings under 400' [122 m], the hopper is placed at one end and the control pan/power unit at the other end. See **Figure 81**.

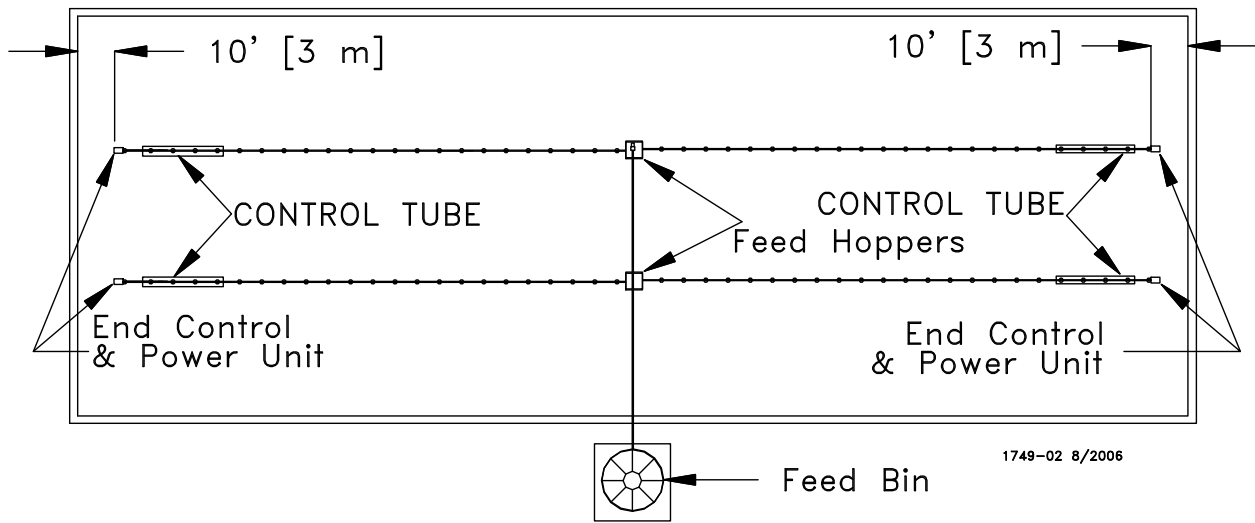

Figure 80. Component location diagram for systems over 400 feet [122 m]. (Top View).

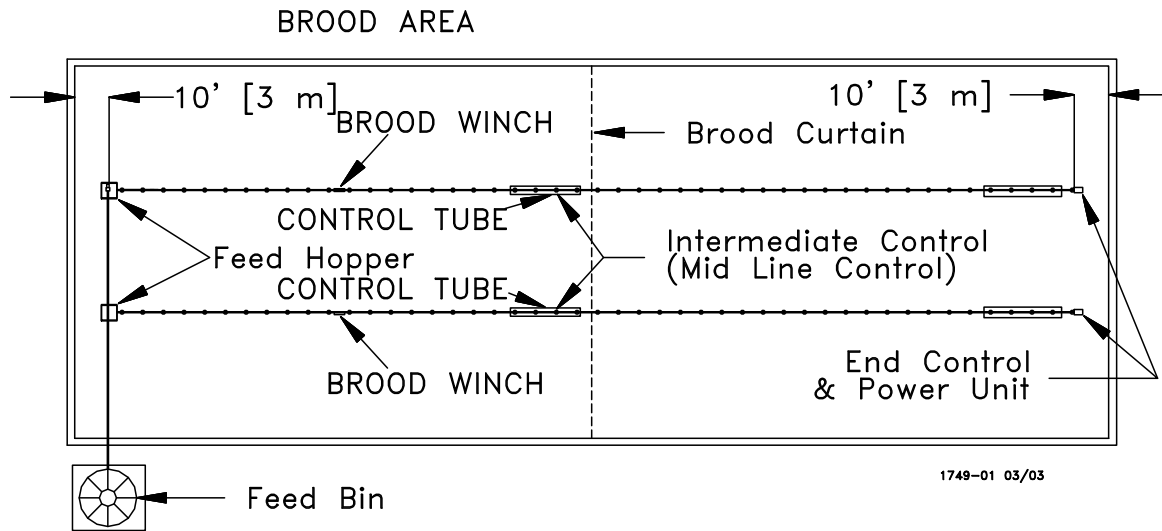

Figure 81. Component location diagram for systems up to 400 feet [122 m]. (Top View).

The feeder tubes and auger are supplied from the factory with a protective oil coating that will cause the system to deliver feed at a reduced rate. The oil coating will also create a larger load on the power unit (motor) until the system has been initially purged with feed, and becomes broken in.

To operate

1. Lower feeder lines so the feed pans are resting on the floor. Although the major weight of the feeder lines will be on the floor, do not remove all the weight from the suspension system and allow the cables to become slack.
2. Apply power to the feeder lines to check the operation. Allow to operate empty for 1-2 minutes.
3. With the shut-off slide on the feed bin boot closed, energize the Flex-Auger® fill system. After operation of approximately 1-2 minutes, open the boot slide 1/2 way to allow feed to be conveyed to the feeders.
4. Once feed begins to be dispensed into the feed hopper(s), manually shut-off the fill system.
5. Apply power again to the feeder lines. Operate the fill system manually to dispense approximately 50 lb. [23 kg] increments of feed into the feed hopper(s). Allow the feed hopper to become empty for 30 seconds between each increment to reduce load on the feeder motor. Continue this procedure until feed has been dispensed to all the feeder pans. When the feed reaches the control pan, the feeder line will be shut-off.
6. Once the feeder lines have been initially filled with feed, manually dispensing feed in 50 lb. [23 kg] increments will no longer be necessary. The shut-off slide on the Flex-Auger® fill system may be completely opened. Refer to the Flex-Auger fill system Operator's Manual for information when multiple feed bins are used.

General Operation of the REVOLUTION® 8 Feeders

The REVOLUTION® 8 has been designed to feed adult roosters.

The Non-Indexed feeder system should be run while the feeder is raised in the air. At feeding time the feeder will then be lowered to eating height for the roosters.

The Indexed feeder system does not need to be raised in the air to fill the feeder pans.

With Window Feeders, the amount of feed per pan can be adjusted by using the actuator and feed level settings. Follow the guide below to set up the feeding system.

With Non-Window Feeders, the amount of feed per pan can also be adjusted with the feed level settings.

REVOLUTION® Rooster Feeder Operation Guide

•Feed weight per cubic ft. Example 40 lbs per cubic ft.

1. Determine the amount of feed to be fed out to the birds. Example 320 lbs.
2. Determine the number of feed pans on the Rooster feed-line. Example 88
3. Divide the feed by the number of feed pans. Example $320 \text{ lbs} / 88 \text{ pans} = 3.63 \text{ lbs per pan}$
4. Use the chart below to determine the setting for the actuator and feed level adjustment.

Feed Level setting	Actuator Setting	40 lb. per cubic ft.	38.4 lb. per cubic ft.
		weight in lbs	weight in lbs
1	1	1.03	0.825
1	2	1.04	0.80
1	3	1.33	1.08
1	4	1.93	1.40
1	5	2.46	1.51
2	1	1.21	0.92
2	2	1.175	1.00
2	3	1.625	1.295
2	4	2.24	1.67
2	5	2.84	1.94
3	1	1.395	1.04
3	2	1.50	1.09
3	3	1.97	1.43
3	4	2.86	1.89
3	5	3.18	2.15
4	1	1.53	1.19
4	2	1.74	1.285
4	3	2.27	1.68
4	4	3.26	1.97
4	5	3.51	2.33
5	1	1.71	1.365
5	2	2.02	1.385
5	3	2.43	1.89
5	4	3.49	2.165
5	5	3.905	2.68

Using 3.63 lbs per pan and 40 lbs per cubic foot the setting for the actuator will be #5 with the a feed level setting of #4. This example is a guide only.

5. After the feeder has been set run feed in the system.
6. Check the weight in the feed pan.
7. Adjust the setting if necessary to reach the desired amount of feed.

End Control Pans

At installation time, the end control pan of the feeder was placed to be 10 feet [3 m] from the end of the building to allow the birds access around the end of the feeder line. It is important the feed setting of the end control pan be the same as the rest of the feeder pans so the birds activate the feeder.

Maintenance

Floor Feeding System Maintenance

The REVOLUTION 8 Feeder require's minimum maintenance. However, a routine periodic inspection of the equipment will prevent unnecessary problems.

Maintenance should be done by a qualified technician.

ALWAYS DISCONNECT POWER TO THE SYSTEM WHEN SERVICING OR MAINTAINING THE EQUIPMENT. FAILURE TO DISCONNECT POWER MAY CAUSE INJURY OR DEATH.

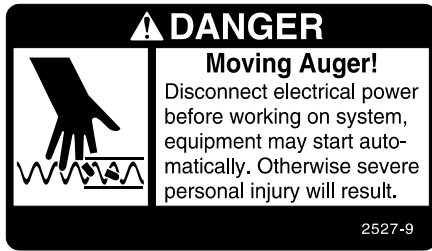

Gear Head Maintenance

Refer to

Check the oil level in the gear heads at installation and every 6 months. The Pipe Plug, on the side of the gear head, indicates proper oil level. Add SAE 40W oil when necessary.

The oil in the gearheads should be replaced every 12 months with new SAE 40W oil

- A. Remove the bottom Pipe Plug to drain the oil. Discard used oil in accordance with local and national codes.
- B. Wipe any debris off the magnet on the bottom Pipe Plug and reinstall. Remove the side Pipe Plug and (top) Vent Plug.
- C. Set the power unit in the horizontal position.
- D. 2-Stage Gearheads: Add approximately 9 oz. (266 ml) of SAE 40W oil through top hole. This should be just enough oil to reach the side Pipe Plug.
3-Stage Gearheads (3261-9, 3261-12, 3261-14): Add approximately 13 oz. (384 ml) of SAE 40W oil through top hole. This should be just enough oil to reach the side Pipe Plug.
- E. Install the side Pipe Plug and (top) Vent Plug.

Vent/Oil Fill Plug



1660-22 1/2001

Check the oil level in Gearhead at installation.

Check the oil level every 6 months.

Check the oil level at the side plug if oil is needed use SAE 40W.

Oil capacity for the 2 stage gearhead is 9 oz [266 ml]

Oil capacity for the 3 stage gearhead is 13 oz [384 ml].
The oil should be changed every 12 months.

Figure 82. Gearhead Maintenance

Check equipment for loose hardware after the first flock and then every 6 months--including the Anchor Block. Tighten if necessary.

SENSOR PLUS™ Sensor Switch Adjustment for Control Units

The SENSOR PLUS™ Pan Half Round Sensor Switch is adjusted at the factory to a sensitivity of .25" [6 mm] from the face of the sensor and a time delay of 15 seconds with the range selector in the "2" position. The time delay adjustment is 0 seconds to 600 seconds.

To adjust the Time Delay: Refer to **Figure 83**.

- For less time — turn Time Delay Adjustment Screw counter-clockwise (Light blinks fast)
- For more time — turn Time Delay Adjustment Screw clockwise (Light blinks slow)

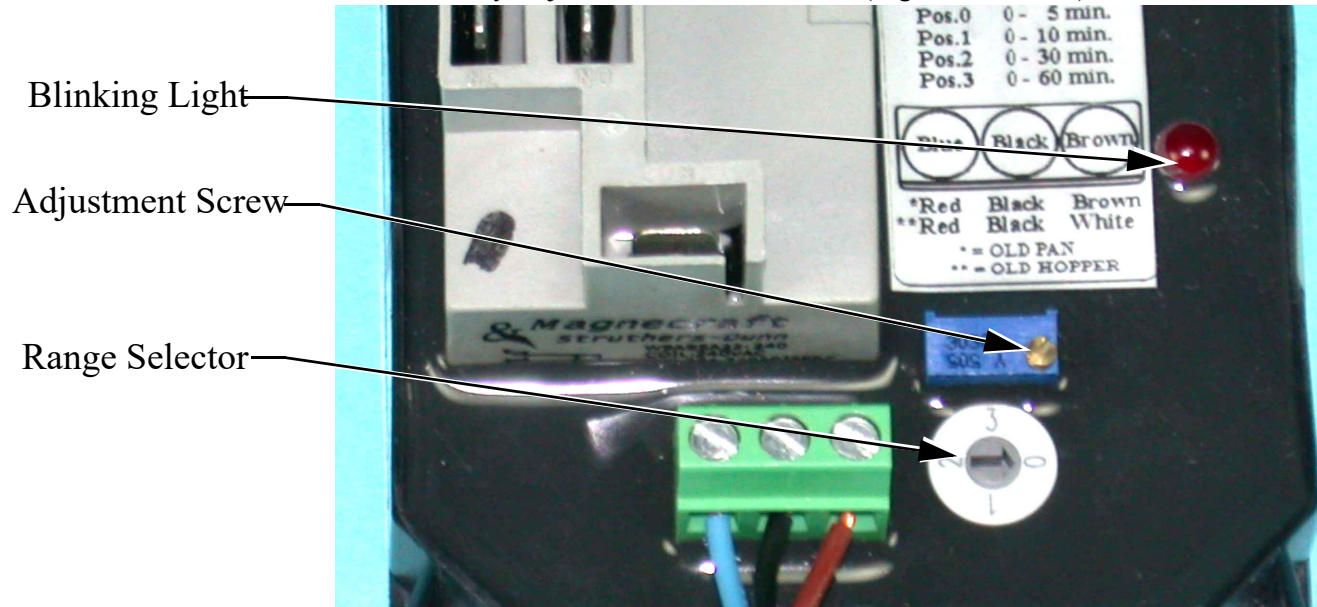

Figure 83. Adjusting the SENSOR PLUS Proximity Switch

Feeder Line

Keep anti-roost cables tightly stretched. This increases the effectiveness of the electro-guard anti-roost system and keep the pans from being tilted when birds push against them.

Remove all feed from the feeder when there are no birds in the house and when the building is washed and disinfected.

Turn the feeders off prior to removing the birds from the house. This will allow them to clean the feed out of the pans.

If the system is not to be used for an extended period of time, remove all the feed from the feeder lines and feeder pans.

Disconnect power to the system to prevent accidentally starting the system.

If the system must be disassembled, extreme caution must be used to prevent injury from springing auger.

1. Disconnect power to the entire system.
2. Loosen the Tube Clamp on the bearing at the hopper end of the system. Remove the Tube Clamp and Bearing Retainer.
3. Pull the Anchor and Bearing Assembly and approximately 18" [45 cm] of auger out of the boot.

CAUTION: Stand clear...the auger may spring back into the tube.

4. Place a clamp or locking pliers securely on the auger to prevent it from springing back into the auger boot.
5. Loosen the setscrew in the bearing assembly shaft and remove the Anchor and Bearing Assembly from the auger.

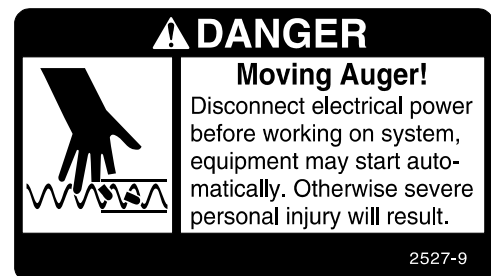

To reinstall the Anchor and Bearing Assembly:

1. Insert the Anchor Assembly into the auger until it touches the washer at the back of the anchor. Tighten the setscrews in the center of the anchor until they touch the auger, then tighten a maximum of 1/2 turn. See **Figure 84**.
2. **DO NOT OVERTIGHTEN THE SET SCREWS.**
3. **Carefully** remove the locking pliers while holding onto the Anchor and Bearing Assembly and auger securely.
Slowly ease the auger back into the tube. Use caution. If the auger is allowed to spring back, the bearing race may crack.

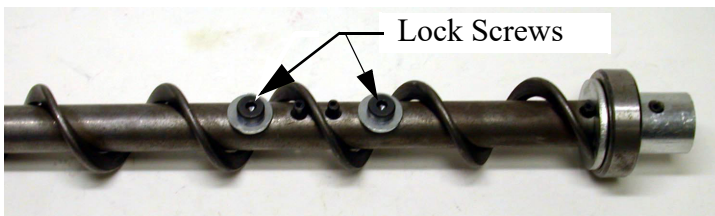

Figure 84. Auger and anchor Bearing Connection

Install the Bearing Retainer and fasten with a tube clamp. Keep the Bearing Retainer flush with the end of the anchor for safety.

Power Lift Winch Maintenance

Refer to **Figure 85**.

Grease the winch every 6 months with 1 to 2 shots of common industrial or automotive grease.

DO NOT OVER GREASE THE WINCH.

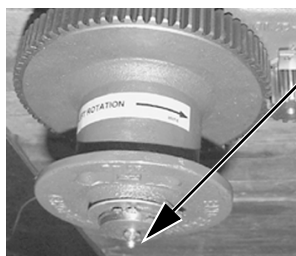

1660-24 6/2001

Grease the Power Lift Winch every 6 months with one or two pumps of common industrial or automotive grease. **DO NOT** over grease the Power Lift Winch!

Figure 85. Maintenance to the Power Lift Winch

Remove any feed build-up in the Safety Switch Boxes in the Control Units.

It may be necessary to periodically re-tighten the shocker cable. Be sure to disconnect power to the shocker before servicing the equipment.

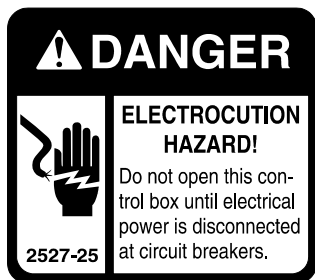

Trouble Shooting the Floor Feeding System

ALWAYS DISCONNECT POWER TO THE SYSTEM WHEN SERVICING OR MAINTAINING THE EQUIPMENT. FAILURE TO DISCONNECT POWER MAY CAUSE INJURY OR DEATH.

Service and maintenance work should be done by a qualified technician only.

Problem	Possible Cause	Corrective Action
None of the feeder lines will operate	No power supplied to equipment	Replace burned fuses or reset circuit breaker Make sure voltage required is supplied
	Time Clock or relay defective	Replace Time Clock or relay
	Time Clock improperly programmed	Refer to Programming the Time Clock section and reprogram the Time Clock
Feeder line will not operate	Power unit cord not plugged in sufficiently to make contact	Check motor cord plug at control unit and control unit plug at outlet for connection
	Motor cord wires are broken at plug or where cord enters motor	Check cord for continuity Replace if defective
	Power Units thermal overload tripped	Push motor overload reset button to reset
	Control unit switch defective or out of adjustment	Adjust switch according to the Switch Adjustment Procedure in the maintenance section
Motor overloads frequently	Oil on new auger loads motor excessively when feed is carried for first time	Polish auger by running 50 lb (20 kg) increments of feed out to pans
	Inadequate power reaching motors	Check line voltage at the motors Check starting current draw at motors Wiring of adequate size is essential to feeder operation
	Object caught in the auger; motor runs, stalls, then auger spins in reverse	Check hopper boot, control unit and pan outlet holes for foreign objects Remove obstruction
Auger runs erratically	Frozen or cracked bearing at boot anchor	Replace bearing Slowly ease auger back into tube Be careful not to damage the bearing when reinserting the auger
	Insufficient stretch in auger	Shorten the auger
	Obstruction in the auger	Remove obstruction
Auger tube or boot wears out rapidly (Noisy feeder operation)	Auger is bent or kinked	Repair or replace damaged auger
	End of auger is riding up on anchor weldment	Auger must not be positioned over weld on anchor Check for bent or damaged auger
Oil leaking out of seals on power unit	Gearhead vent plug not installed	Replace plastic shipping plug with vent plug
	Defective gear head seal	Replace seal
Not enough feed supplied to the feeder pans	Insufficient time programmed on the time clock	Add more operating time to feeding period
	Feeder line control unit switch out of adjustment	Adjust switch according to the Switch Adjustment Procedure in the maintenance section
Brood openings will not stay in sync	Loose plastic cable clamp	Tighten the plastic cable clamps
Actuator will not move cones	Cable loose	Tighten cable
One pan will not operate	Loose or missing Pivot bracket	Tighten loose parts
Control pan does not function	Check operation of switch, check time delay check time delay selector	clean off any buildup make sure time delay is working select position 0 for control
Pan will not stay in adjustment	To much pressure or movement in one direction	Reset Brood opening, refer to Setting the Actuator.
Pivots Break	To much pressure on cable	Reset Brood opening, refer to Setting the Actuator.

Wiring Diagrams

Internal Wiring End Control

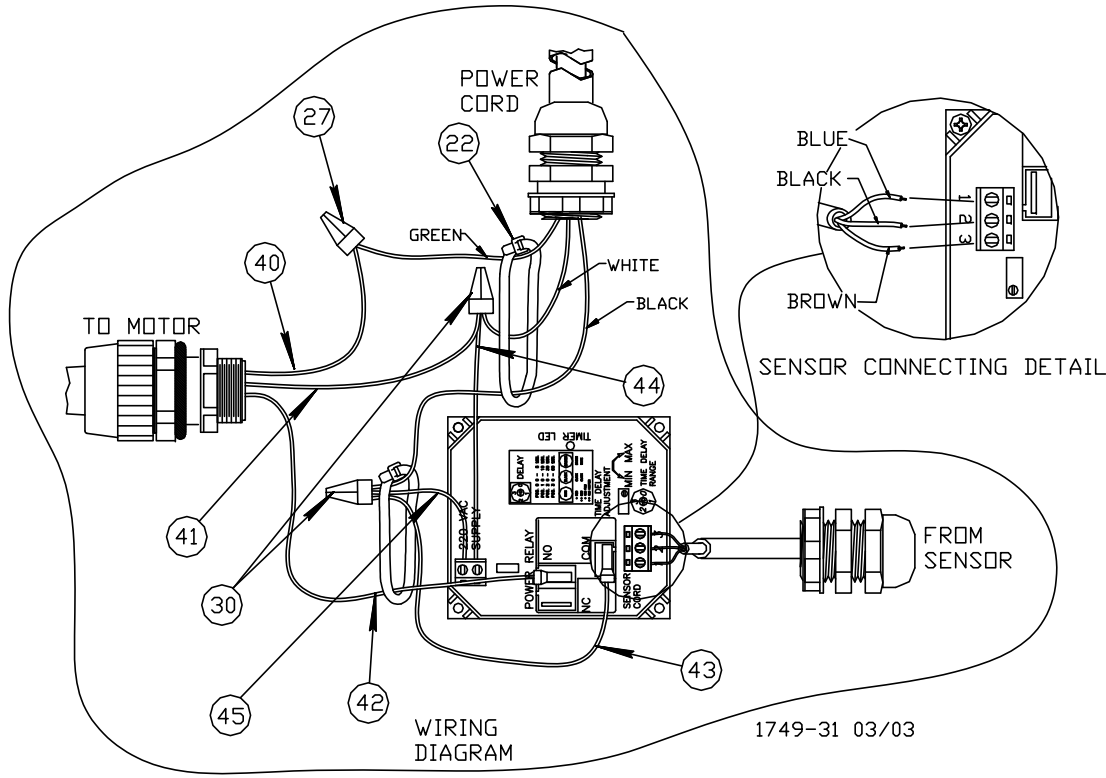

Sensor Plus End Control

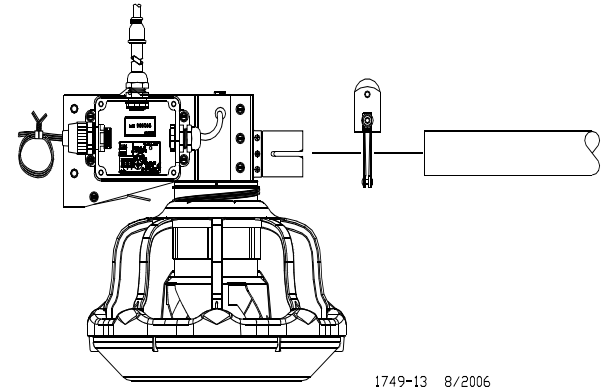

SENSOR PLUS™ Control Wiring Diagram

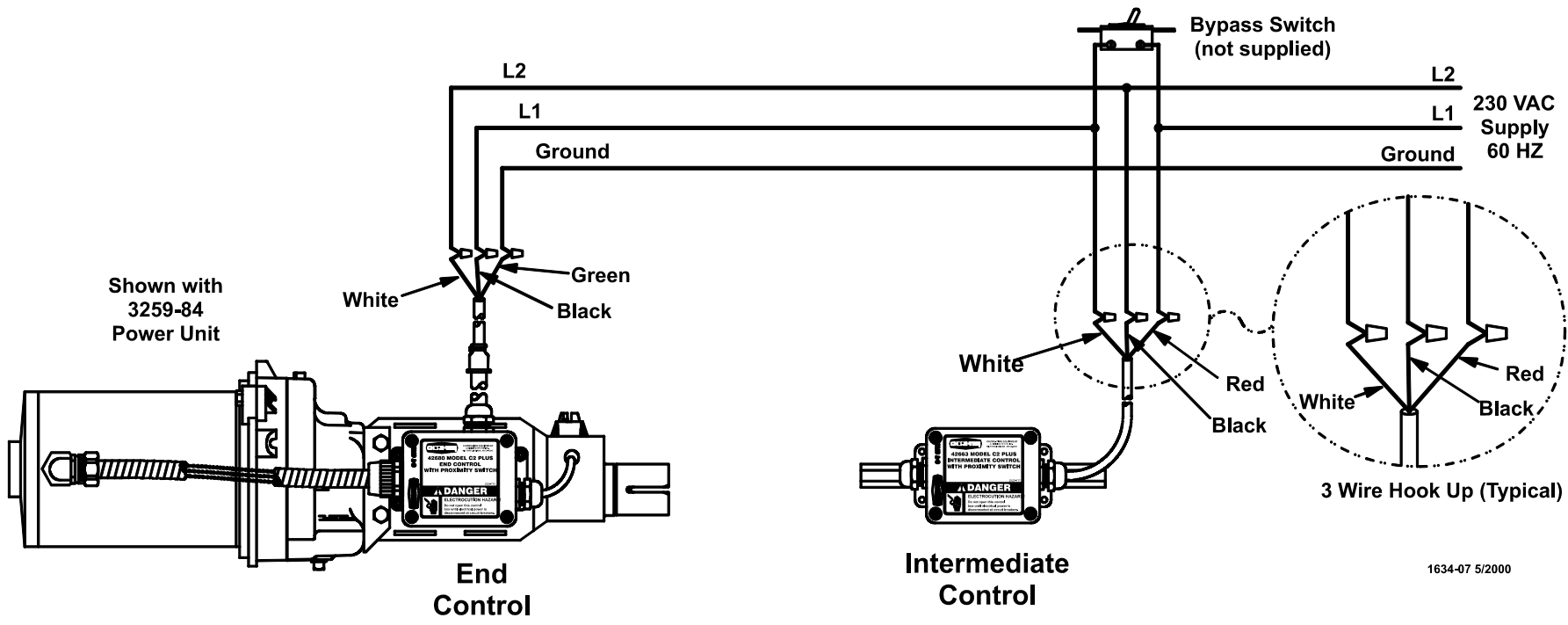

SENSOR PLUS™ Three Phase(Ø) Wiring

FROM DISCONNECT OR
CONTROL DISCONNECT
220/380 VOLTS 50 HZ.
THREE PHASE

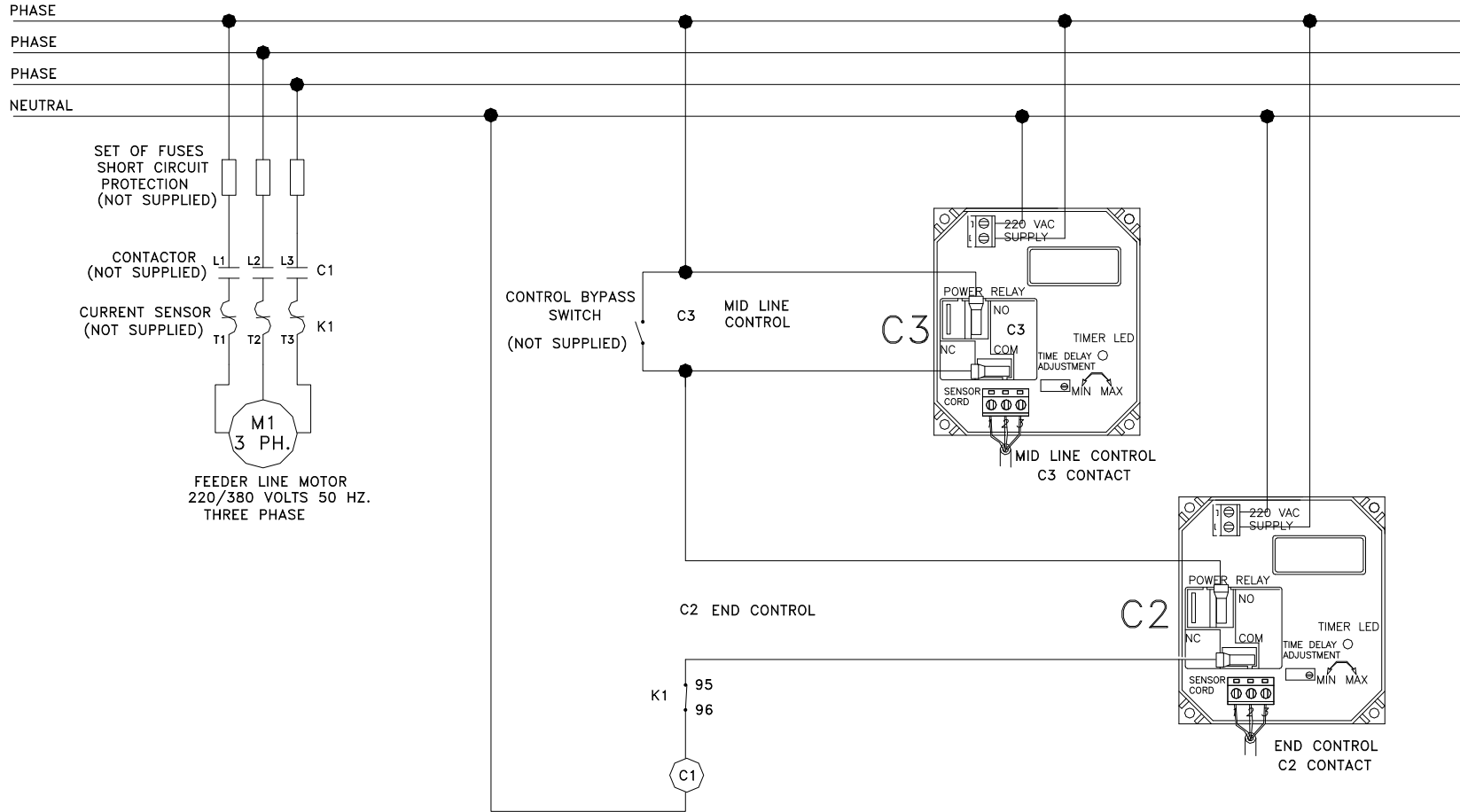

TO ADDITIONAL
FEEDER LINES

232-62 4/05

Parts Listing

150# Hopper Components

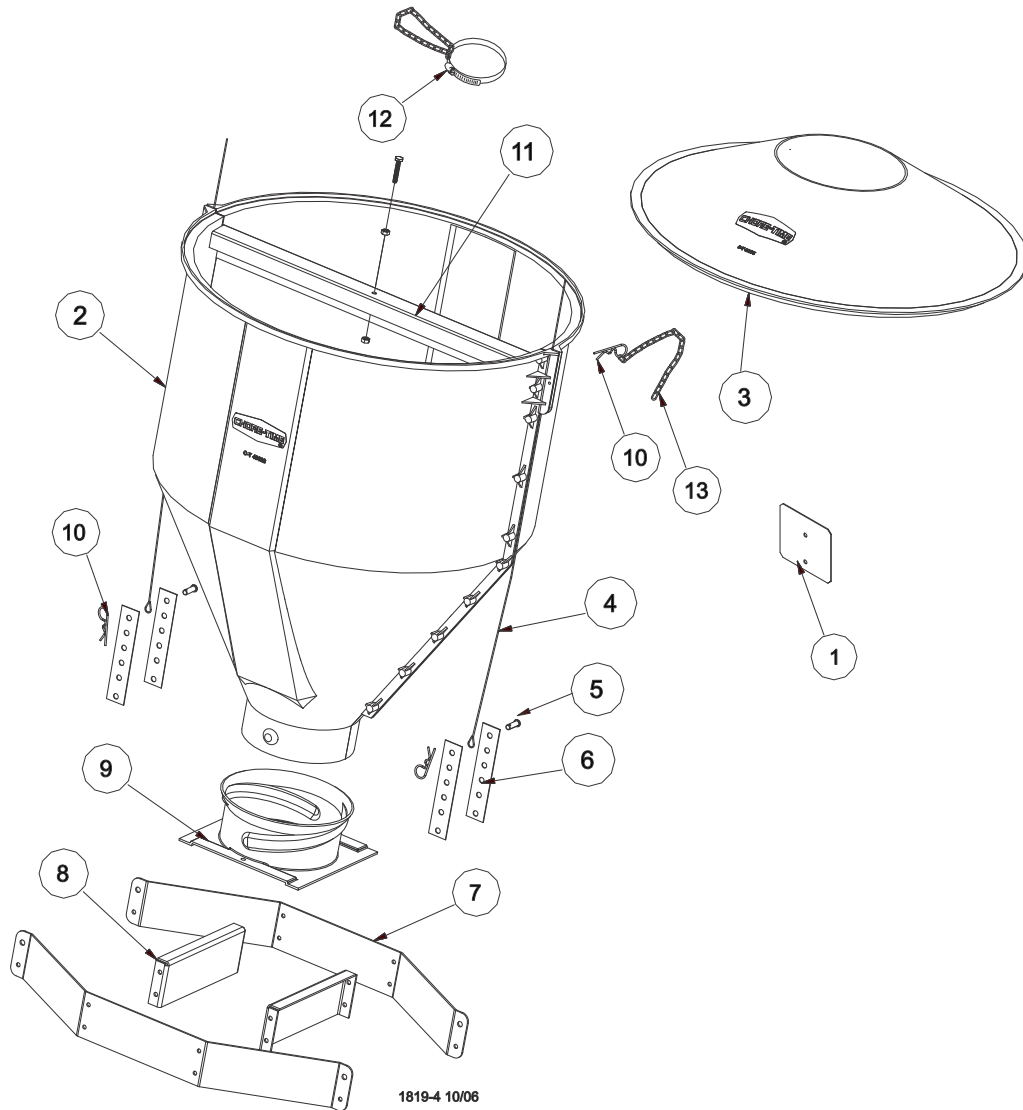

Item	Description	Without	With
		Cover	Cover
		48926	49267
1	Hopper Half	49028	49028
2	--	--	--
3	Cover	--	48675
4	Cable Assembly	2809-3	2809-3
5	Clevis Pin	2797-1	2797-1
6	Adjustment Bracket	2706	2706
7	Suspension Angle	48679	48679

*Item must be ordered in either 100 ft or 250 ft quantities, 2128-100 is 100 ft and 2128-250 is 250 ft.

Item	Description	Without	With
		Cover	Cover
		48926	49267
8	Suspension Brace	48680	48680
9	Twist Lock Collar	49041	49041
10	Hairpin	2664	2664
11	Brace	49029	49029
12	Tube Support Assembly	14367	14367
13*	Chain	2128	2128
14	Switch Backup Plate	50966	50966

Part Number 49358-Hopper Suspension Kit

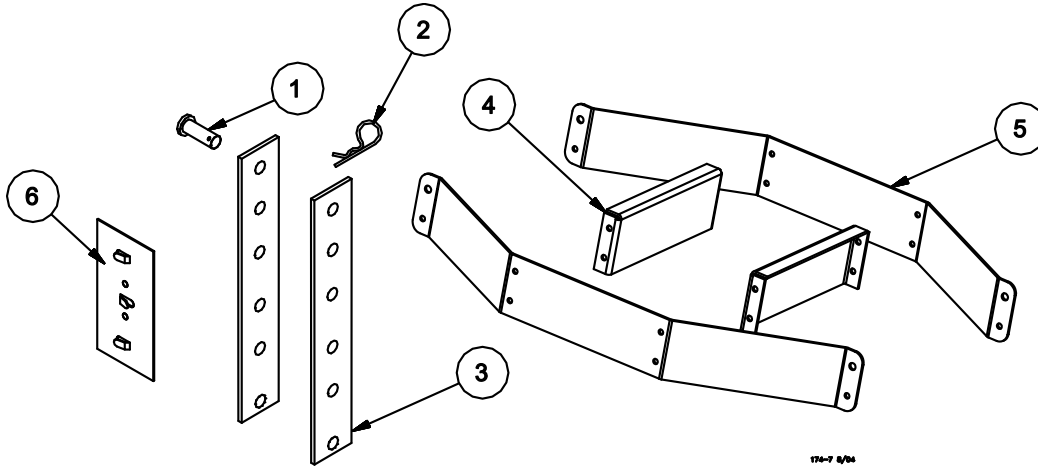

Item	Description	Part No. Single Boot Kit	Part No. Twin Boot Kit
1	Clevis Pin, 5/16" x 1"	2797-1	2797-1
2	Adjustment Bracket	2706	2706
3	Hair Pin	2664	2664
4	Suspension Brace	48680	48680
5	Suspension Angle	48679	48679
6	Cable Guide	34573	34573

Note: This kit is used for steel hopper suspension.

Single Boot Components Part No. 6822

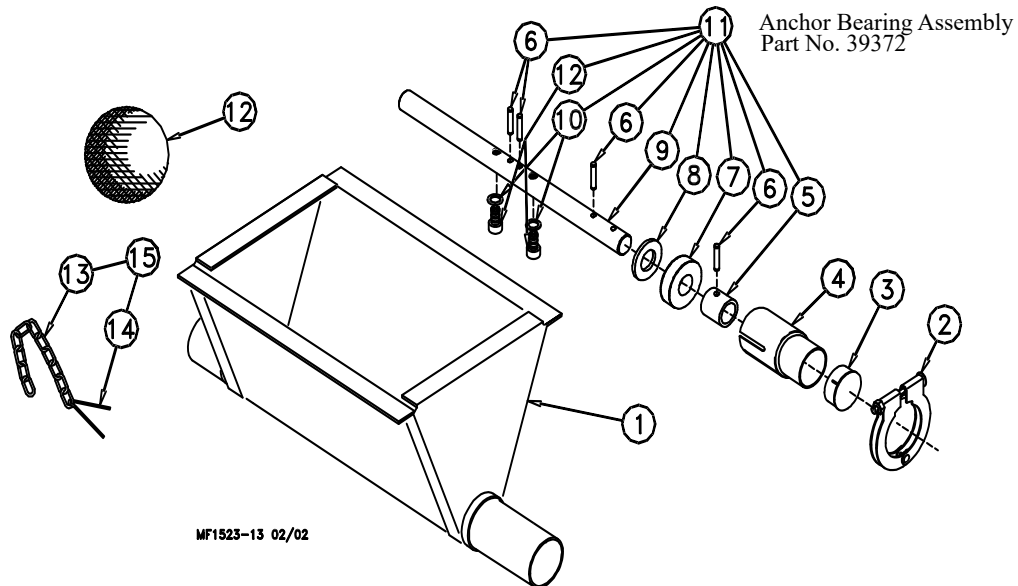

Item	Description	Part No.
1	Boot Weldment	3760
2	Tube Clamp	24063
3	Cap	29373
4	Outlet Tube	4556
5	Sleeve	5648
6	3/16 x 1" Pin	2960-1
7	Bearing	2689
8	Washer	2955-14

Item	Description	Part No.
9	Anchor	38540
10	Setscrew	47867
11	Anchor and Bearing Ass'y	39372
12	Cannonball	3531
13	Latch Pin Ass'y	2683
--	Danger Decal	2527-9

Twin Boot Components Part No. 6824

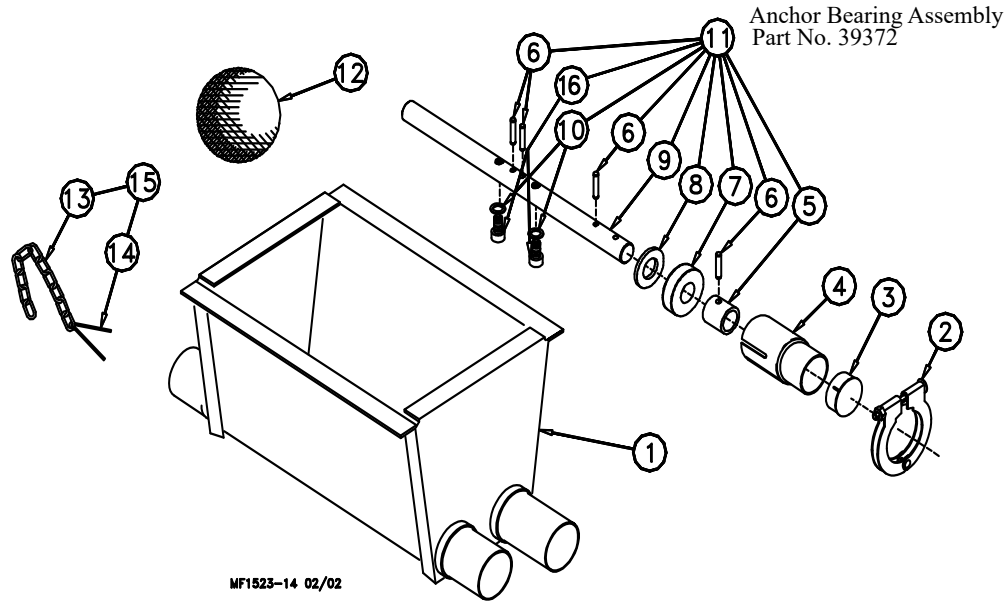

Item	Description	Part No.
1	Boot Weldment	3932
2	Tube Clamp	24063
3	Cap	29373
4	Outlet Tube	4556
5	Sleeve	5648
6	3/16 x 1" Pin	2960-1
7	Bearing	2689
8	Washer	2955-14
9	Anchor	38540

Item	Description	Part No.
10	Setscrew	47867
11	Anchor and Bearing Ass'y	39372
12	Cannonball	3531
13	Latch Pin Ass'y	2683
--*	Jumper Wire Kit	5360
--	Danger Decal	2527-9

*The Jumper Wire Kit includes an insulated piece of High-Voltage Wire (part no. 28994) and (2) cable clamps.

Feeder Line Components

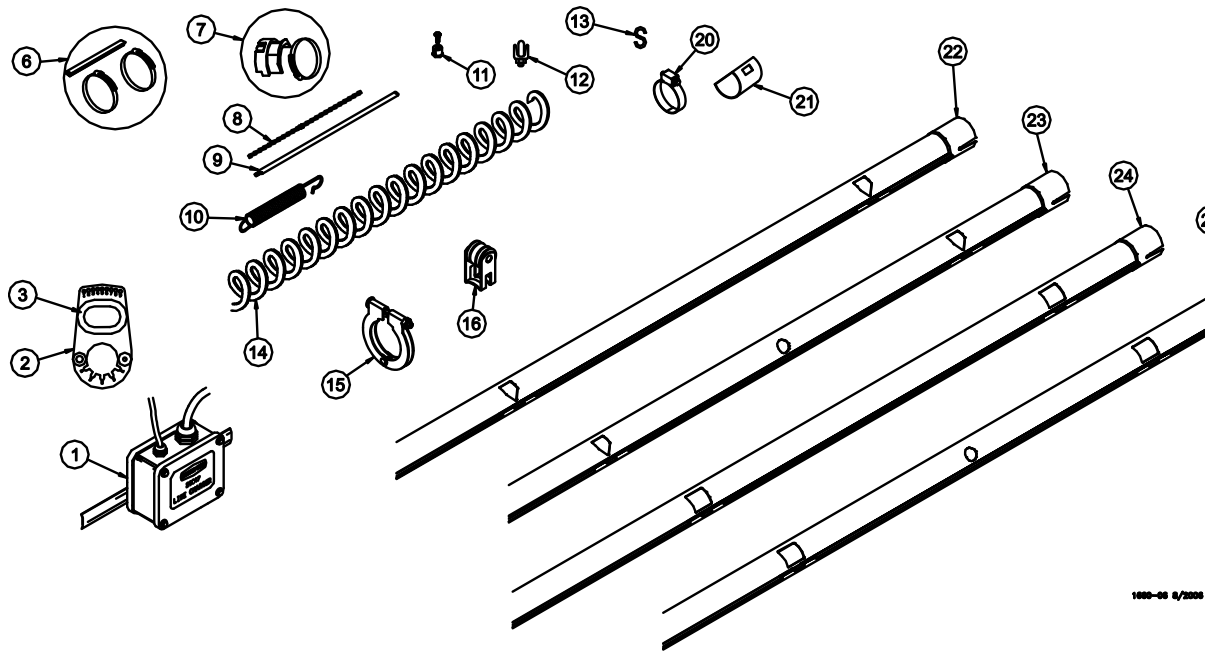

1000-00 8/2008

Item	Description	Part No.
1	Line Charger (110v)	29317
	Line Charger (220v)	29341
2	Hanger Assembly	7604
3	Grommet	14899
4	---	---
5	---	---
6	Anti-Swing Bracket Kit	14458
7	Anti-Swing Bracket Kit	50151
8	1/16" Cable	1922
9	Charger Wire (165')	28994-165
	Charger Wire (330')	28994-330
10	Spring	7551
11	1/16" Cable Clamp	1826
12	1/8" Cable Clamp	14898
13	"S" Hook	723
**14	Auger	6820-0WM
15	Tube Clamp	24062
16	Anti-Roost Bracket	24060
17	---	---
18	---	---
19	---	---
*20	Adjustment Clamp	3527
*21	Tube Closure	9126

Item	Description	Part No.
22	Standard Feeder Tube - 1 3/4" Roll Form	
	- 9', 4 Hole Tube	6854-1
	- 10', 3 Hole Tube	6854-5
	- 10', 4 Hole Tube	6854-4
	- 12', 3 Hole Tube	6854-8
	- 12', 4 Hole Tube	6854-7
	- 12', 5 Hole Tube	6854-6
23	Standard Feeder Tube-1 3/4" with Chick Holes (EZ. Holes)	
	- 9', 4 Hole, 4 EZ. Holes	6854-15
	- 10', 4 Hole, 4 EZ. Holes	6854-16
	- 12', 4 Hole, 4 EZ. Holes	6854-17
	- 12', 5 Hole, 5 EZ. Holes	6854-18
	- 10', 3 Hole, 3 EZ. Holes	6854-19
	- 9', 4 Hole, 2 EZ. Holes	6854-20
	- 10', 4 Hole, 2 EZ. Holes	6854-21
- 12', 4 Hole, 2 EZ. Holes	6854-22	
24	Control Feeder Tube-1 3/4" Roll Form	
	- 9', 4 Hole Tube	43006-1
	- 10', 4 Hole Tube	43006-4
	- 10', 3 Hole Tube	43006-5
	- 12', 3 Hole Tube	43006-8
	- 12', 4 Hole Tube	43006-7
	- 12', 5 Hole Tube	43006-6
25	Control Feeder Tube-1 3/4" with Chick Holes (EZ. Holes)	
	- 9', 4 Hole, 4 EZ. Holes	43006-15
	- 10', 4 Hole, 4 EZ. Holes	43006-16
	- 12', 4 Hole, 4 EZ. Holes	43006-17
	- 12', 5 Hole, 5 EZ. Holes	43006-18

*These parts may be ordered as a kit under part number: 14585.
 **Round up to the nearest 10'. Auger lengths from 50' to 500'. Example: 6820-200WM would be a 200' roll of 6820WM Auger.

Power Unit Assemblies

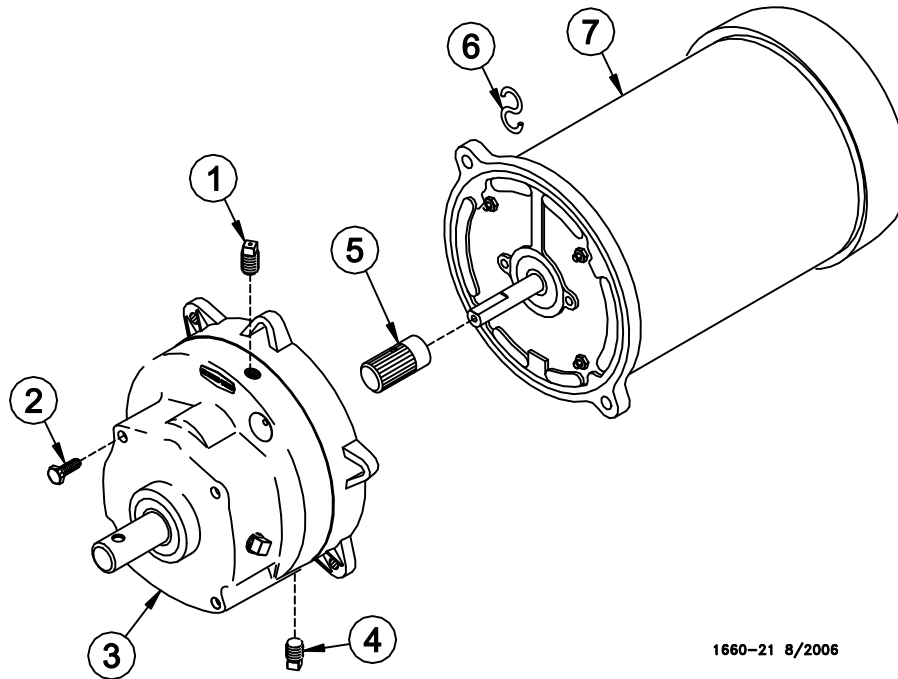

1660-21 8/2006

Item	Description	3259-81 Part No.	3259-84 Part No.	3259-85 Part No.	3259-98 Part No.	3259-100 Part No.	3259-101 Part No.	3259-144 Part No.	3259-153 Part No.
1	Vent Plug	3523	3523	3523	3523	3523	3523	3523	3523
2	5/16-18x5/8 Hex Hd Screw	4412-1	4412-1	4412-1	4412-1	4412-1	4412-1	4412-1	4412-1
3	Gearhead	3261-11	3261-5	3261-5	3261-11	3261-11	3261-11	3261-17	3261-17
4	Pipe Plug (magnetic)	30160	30160	30160	30160	30160	30160	30160	30160
5	Pinion Assembly	5046	5046	5046	5046	5046	5046	5046	5046
6	"S" Hook	2805	2805	2805	2805	2805	2805	2805	2805
7	Motor	7522	4229	5703	5977	28031EUR	28032EUR	5051	34102
--	Cord Assembly	28029	----	----	----	----	----	28029	----
--	Connector (90 Degree)	4228	----	----	----	----	----	4228	----

Power Unit Assembly Part Numbers:

Part No.	HP	RPM	Phase	Hz	Voltage
3259-81	3/4 HP	708 RPM	Single Phase	50 Hz	230
3259-84	1/3 HP	348 RPM	Single Phase	60 Hz	230
3259-85	1/2 HP	348 RPM	Single Phase	60 Hz	230
3259-98	1/2 HP	348 RPM	Single Phase	50 Hz	230
3259-100	1/2 HP	348 RPM	Three Phase	50 Hz	220/380
3259-101	3/4 HP	696 RPM	Three Phase	50 Hz	220/380
3259-144	3/4 HP	696 RPM	Single Phase	60 Hz	230
3259-153	1 HP	696 RPM	Three Phase	60 Hz	230

Sensor Plus End Control

Part No. 48509 REVOLUTION® 8 END CONTROL

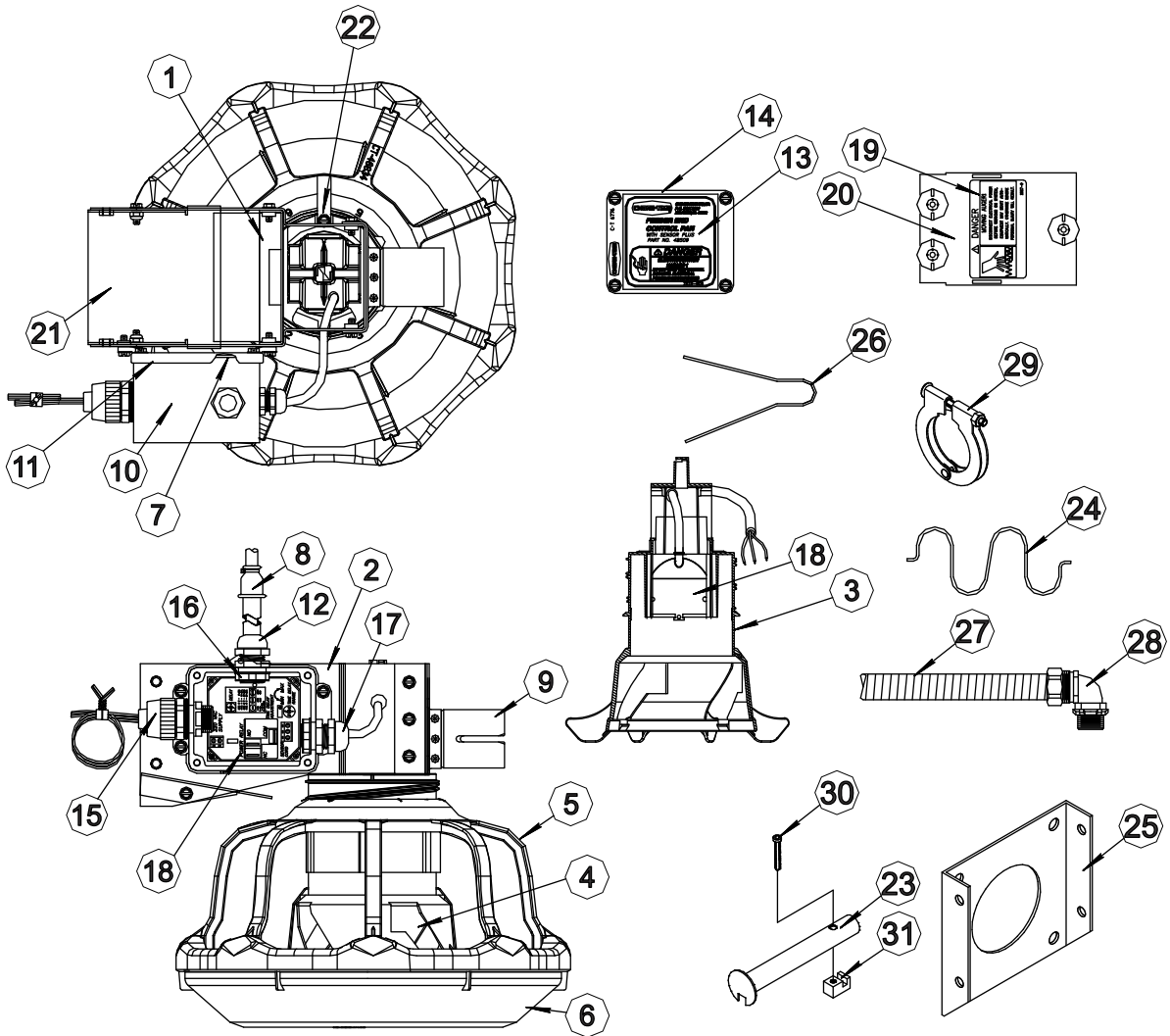

Item	Description	Rev. 8 Feeder end control part #48509
1	SUPPORT BRACKET	48081
2	FEEDER CONTROL BODY	48080
3	SUPPORT CONE MACHINED	48490
4	INNER CONE MACHINED	48533
5	FEEDER GRILL	46834
6	FEEDER PAN	46840
7	SWITCH BOX GASKET	6777
8	CORD ASSEMBLY	4999-100
9	TUBE WELDMENT	48082
10	GENERAL PURPOSE BOX	42627-12
11	TERMINAL BOX MOUNT COVER	6956
12	LIQUID TIGHT CONNECTOR	24685
13	END CONTROL DECAL	2529-808
14	SWITCH BOX COVER	6956
15	LIQUID TIGHT CONNECTOR	26980
16	CONDUIT NUT PLASTIC	43662
17	LIQUID TIGHT CONNECTOR	23779
18	PAN SENSOR	48200
19	DANGER DECAL ROTATION	2527-9
20	INSULATOR COVER	48491
21	END CONTROL BOTTOM COVER	48086
22	LOCK ARM CONTROL	48525
23	DRIVE TUBE WELDMENT	44794
24	SPRING LOCK	48511
25	ANCHOR PLATE	4188
26	ANTI ROOST GUARD	2798
27	1/2" FLEX CONDUIT PLASTIC	26982-1
28	1/2" LIQUID TIGHT CONNECTOR	23810
29	Tube Clamp	24063
30	1/4-20 x 1.75 SOCKET HEAD	5083-8
31	DRIVE BLOCK	4642

50361 ACCU-CLICK™ Rooster Feeder System

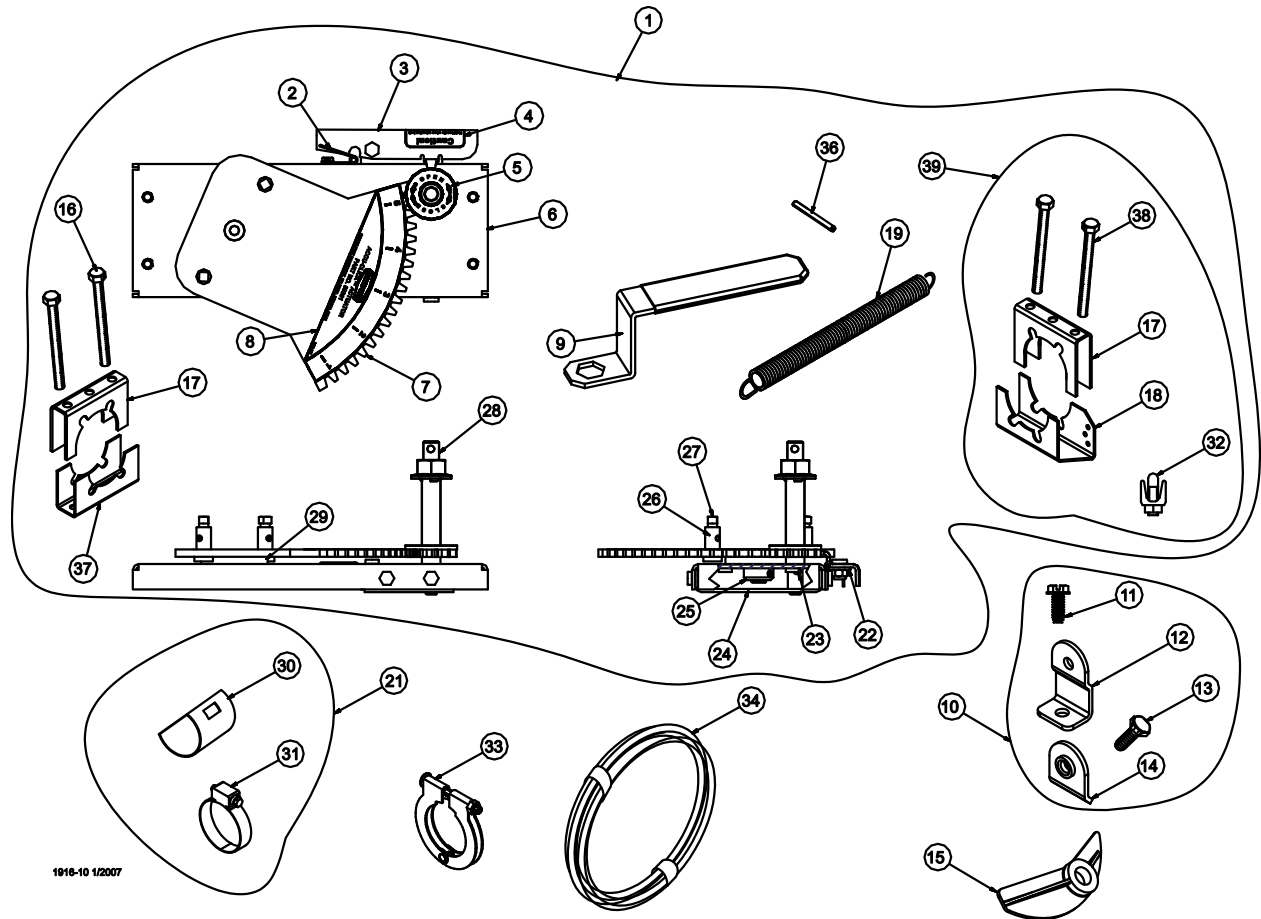

1916-10 1/2007

Item	Part No.	Description
*1	50361	ACCU-CLICK Actuator Assembly
2	4976	Torsion Spring
3	50188	Pawl
4	2525-75	Pawl Decal
5	2526-468	Input Shaft Decal
6	50185	Frame Base
7	50186	Intermediate Gear/Shaft WLDT
8	2529-870	ACCU-CLICK Decal
9	50264	Wrench
10	50705	Pivot Bracket Package
11	6980	#10 x 3/4" Twin Helix Screw
12	50545	Pivot Bracket
13	4416-7	10-24 x 3/8" Screw
14	50546	Pivot Clip
15	50541	Cover Washer
16	4404-26	1/4-20 x 3.25 Hex Bolt
17	48487	Half Clamp
18	49958	Spring Support Bracket
19	24302	Spring
20	----	----

Item	Part No.	Description
21	14585	Tube Closure Kit
22	50187	Pawl Mount
23	4129-1	Grooved Pin
24	50189	Pinion Support Plate
25	34558	Set Collar
26	50193	Pivot Pin
27	5095	5/16-18 SQ HD Set Screw
28	50373	Pinion Gear/Shaft WLDT
29	2955-60	Pivot Washer
30	9126	Tube Closure Kit
31	3527	Adjustment Clamp
32	14898	1/8" Cable Clamp
33	24063	Tube Clamp
34	48530	.125 Dia. Wire (500' roll)
35	----	----
36	2960-8	3/16 Roll Pin
37	50184	Actuator Clamp Base
38	4404-24	1/4-20 x 3.0 Hex Bolt
39	50722	Actuator Hardware Pkg
40	----	----

47687 Power Winch

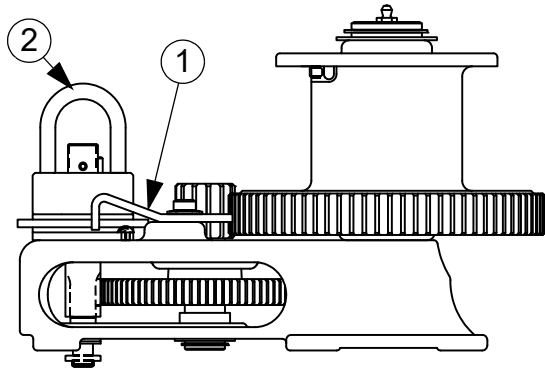

Item	Qty.	Description	Part No.
1	1	Pawl	47687-5
2	1	Input Shaft Assembly	47687-1

Indexing Gauge

Item	Description	Part No
1	Level Glass	4853
2	Gauge Clamp Weldment	14523
3	Pointer Assembly	4852
4	Indexing Level	2529-207

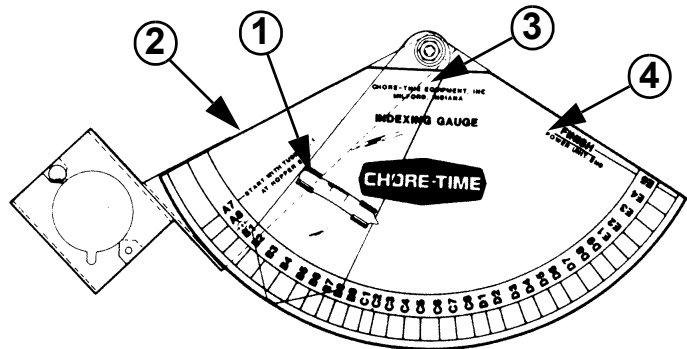

Miscellaneous Suspension Components

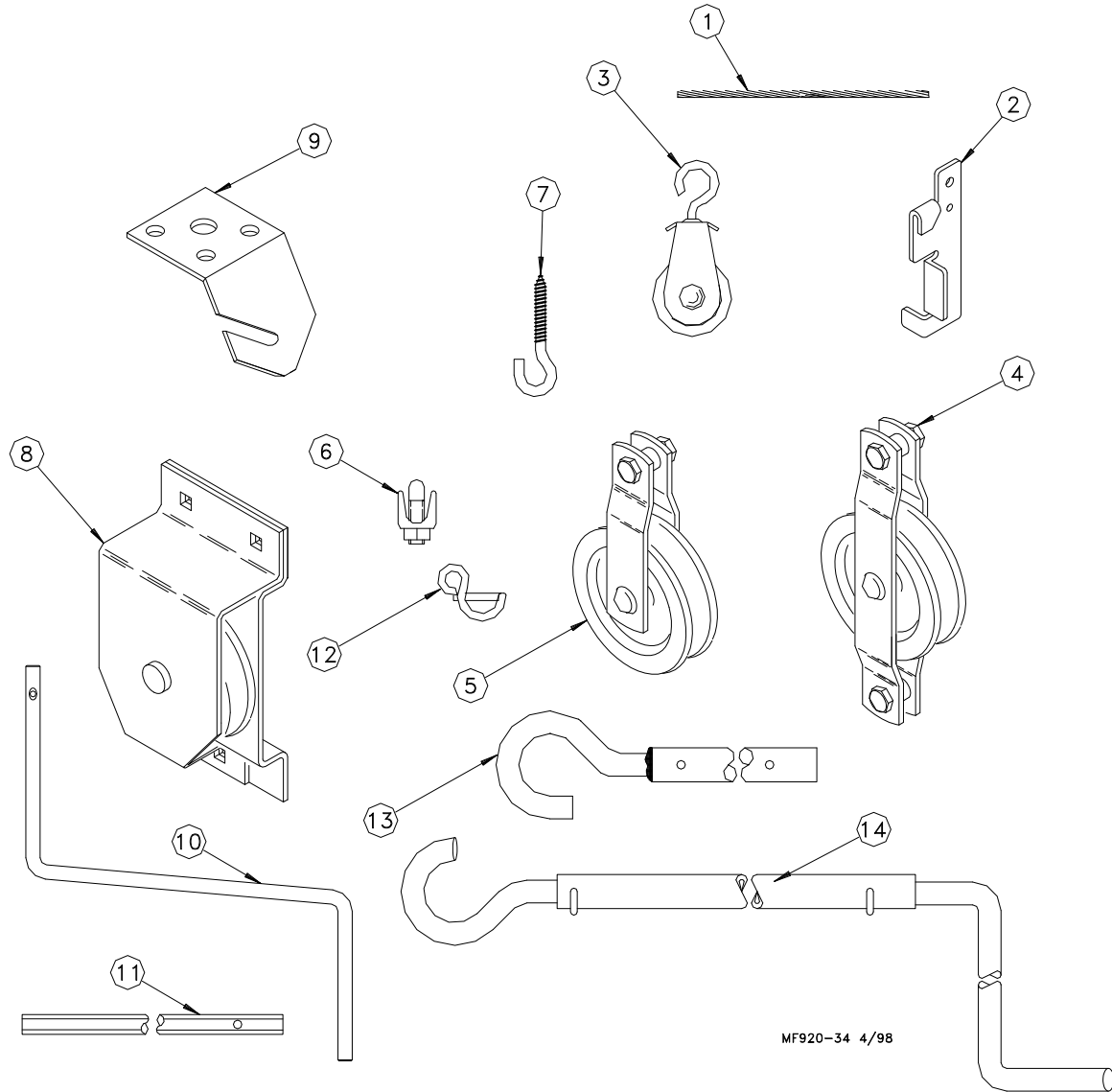

MF920-34 4/98

Item	Description	Part No.
1	3/32" Cable 3/16" Cable 1/8" Cable	4973 1213 27975
2	Cable Lock	14337
3	Pulley with Swivel	3004
4	Double Eye Pulley	2501
5	Pulley	2500
6	3/16" Cable Clamp 1/8" Cable Clamp	732 14898
7	Standard Screw Hook Large Screw Hook	1214 2041

Item	Description	Part No.
8	Pulley Assembly	28429
9	Suspension Bracket Suspension Bracket with Screws	28550 28832
10	Handle Shank	3148
11	Drill Adapter Shaft	3151
12	Winch Handle Pin	3761
13	Winch Drive Tube (4') Winch Drive Tube (8') Winch Drive Tube (2')	2884-1 2884-2 2884-4
14	Telescoping drive handle 5 to 8 foot	47638

Item 10 and Item 12 may be ordered as a kit under part no. 2885.
Item 11 and Item 12 may be ordered as a kit under part no. 2886.

Feeder Components

REVOLUTION 8 Spoke
Male Feeder 50476

REVOLUTION 8 Spoke Male Feeder
NON FLOOD 50477

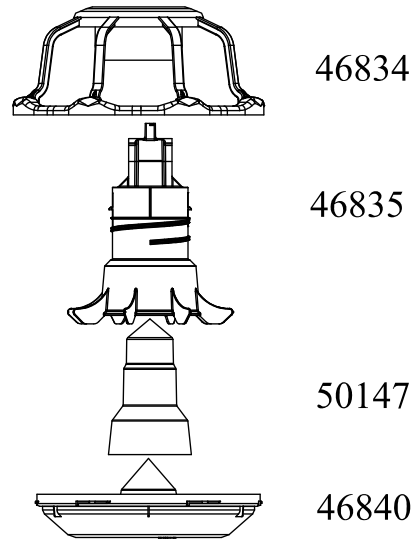
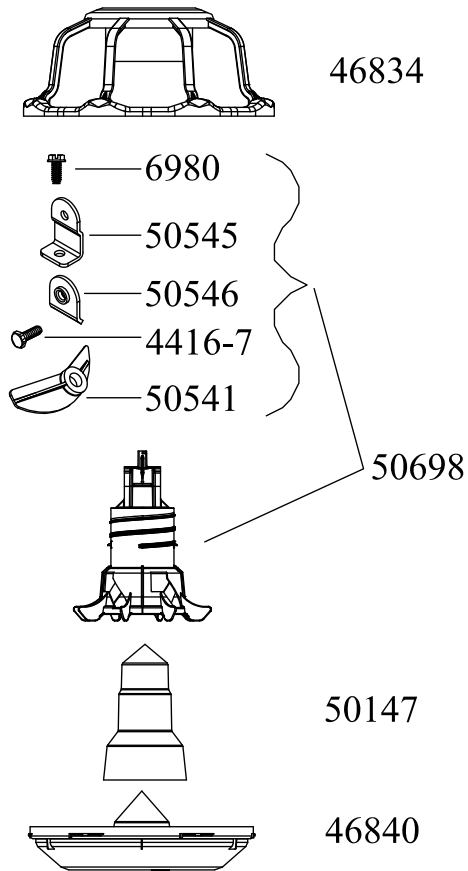

OPTIONAL: REPAIR CAP

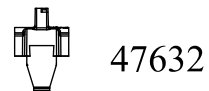

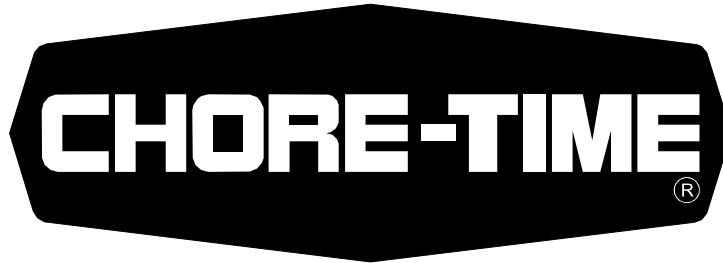

**MADE TO WORK.
BUILT TO LAST.®**

Revisions to this Manual

Page No.	Description of Change	ECO
69	Was 2883 Winch	35577
Various	Various updates to graphics for better printing.	

**For additional parts and information, contact your nearest Chore-Time distributor or representative.
Find your nearest distributor at: www.choretime.com/contacts**

CTB, Inc.
PO Box 2000
Milford, Indiana 46542-2000 USA
Phone (574) 658-4101
Email: choretime@choretime.com
Internet: www.choretime.com