



Poultry Production Systems

CPF Feeding System

Installation and Operators Manual

Installation and Operators Manual

Installation and Operators Manual

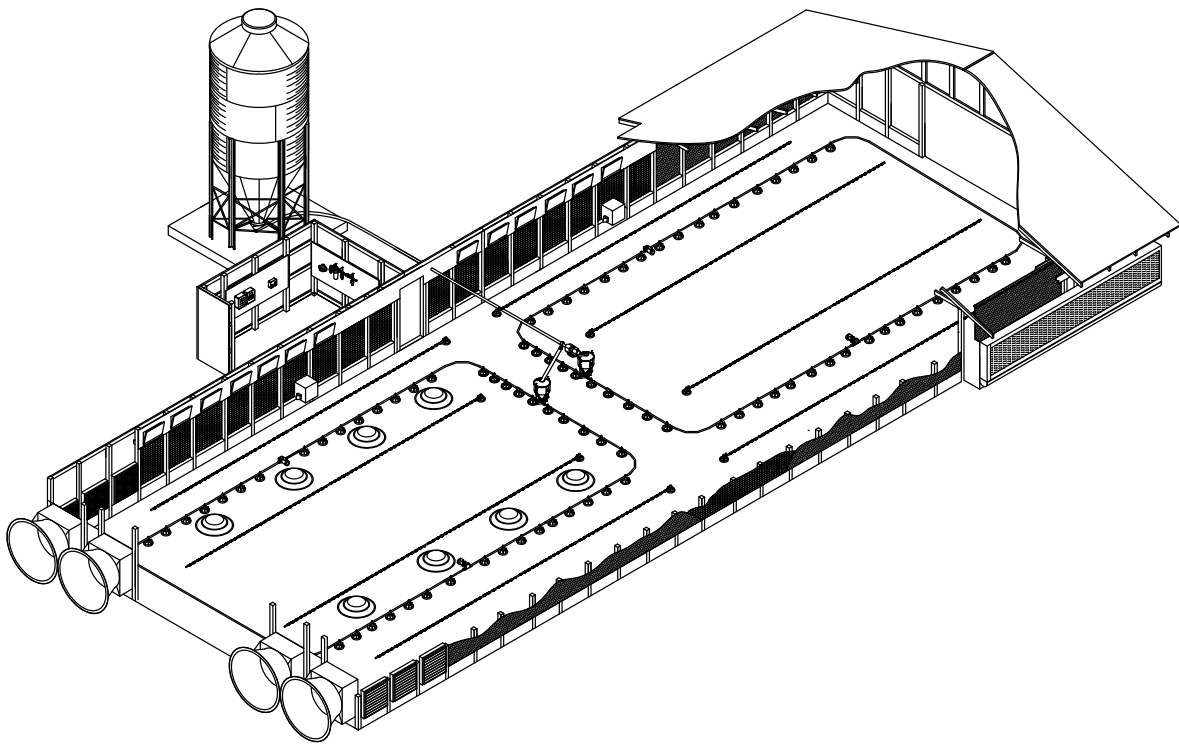

Chore-Time Warranty

CTB, Inc., (“Chore-Time”), warrants each new CHORE-TIME[®] product manufactured by it to be free from defects in material or workmanship for one-year from and after the date of initial installation by or for the original purchaser. If such a defect is found by Chore-Time to exist within the one-year period, Chore-Time will, at its option, (a) repair or replace such product free of charge, F.O.B. the factory of manufacture, or (b) refund to the original purchaser the original purchase price, in lieu of such repair or replacement. Labor costs associated with the replacement or repair of the product are not covered by the Manufacturer.

Additional extended warranties for the equipment and/or systems listed below are provided to the original purchaser as follows (for all other CHORE-TIME[®] products purchased, the one-year warranty period shall apply):

1. TURBO[®] and RLX[™] fans, less motors - 3 years
2. TURBO[®] fan fiberglass housings, polyethylene cones, and cast aluminum blades - for the life of the product
3. TURBO[®] fan motors and bearings - 2 years
4. TURBO[®] fan components (including plastic shutters) - 3 years
5. Poultry feeder pans that becomes unusable within five years from the date of installation - Warranty prorated after three years usage
6. Rotating centerless augers, excluding applications involving high moisture feed stuffs (exceeding 18%), for ten years from the date of installation. Note: MULTIFLO[®] and applications involving high moisture feed stuffs are subject to a one-year warranty
7. Chore-Time manufactured roll-formed steel auger tubes for ten years from the date of installation
8. ULTRAFLO[®] Breeder Feeding System auger and feed trough are warranted for a period of five years from the date of original installation against repeated breakage of the auger or wear-through of the feed trough caused solely by the auger
9. ULTRAPAN[®] Feeding System augers are warranted for a period of five years from the date of installation againstly by the auger

CONDITIONS AND LIMITATIONS

1. The product must be installed by and operated in accordance with the instructions published by the Manufacturer or Warranty will be void.
2. Warranty is void if all components of the system are not original equipment supplied by the Manufacturer.
3. This product must be purchased from and installed by an authorized distributor or certified representative thereof or the Warranty will be void.
4. Malfunctions or failure resulting from misuse, abuse, negligence, alteration, accident, or lack of proper maintenance shall not be considered defects under the Warranty.
5. This Warranty applies only to systems for the care of poultry and livestock. Other applications in industry or commerce are not covered by this Warranty.

Chore-Time shall not be liable for any consequential or special damage which any purchaser may suffer or claim to suffer as a result of any defect in the product. "Consequential" or special damages" as used herein include, but are not limited to, lost or damaged products or goods, costs of transportation, lost sales, lost orders, lost income, increased overhead, labor and incidental costs and operational inefficiencies.

THIS WARRANTY CONSTITUTES THE MANUFACTURER'S ENTIRE AND SOLE WARRANTY AND THIS MANUFACTURER EXPRESSLY DISCLAIMS ANY AND ALL OTHER WARRANTIES, INCLUDING, BUT NOT LIMITED TO, EXPRESS AND IMPLIED WARRANTIES AS TO MERCHANTABILITY, FITNESS FOR PARTICULAR PURPOSES SOLD AND DESCRIPTION OR QUALITY OF THE PRODUCT FURNISHED HEREUNDER.

Chore-Time Distributors are not authorized to modify or extend the terms and conditions of this Warranty in any manner or to offer or grant any other warranties for Chore-Time products in addition to those terms expressly stated above.

An officer of CTB, Inc. must authorize any exceptions to this Warranty in writing. Chore-Time reserves the right to change models and specifications at any time without notice or obligation to improve previous models.

Effective: **April 2005**

Thank You

The employees of Chore-Time would like to thank your for your recent Chore-Time purchase. If a problem should arise, your Chore-Time distributor can supply the necessary information to help you.

***Chore-Time Poultry Feeder Pan Pro Rata Schedule**

Year from date of installation during which pan becomes unusable	Charge to be paid by the purchaser for replacement.
0 - 1 years	NO CHARGE
1 - 2 years	NO CHARGE
2 - 3 years	NO CHARGE
3 - 4 years	4/10 of then current list price
4 - 5 years	5/10 of then current list price

Contents

Topic	Page
Chore-Time Warranty	2
About This Manual	6
Safety Information	6
Safety Instructions	7
Follow Safety Instructions	7
Decal Descriptions	7
DANGER: Moving Auger	7
DANGER: Electrical Hazard	7
CAUTION:	7
General	7
Support Information	7
Manufacturers Recommendations: Birds per Pan	8
Planning the System	9
General Installation Information	11
Laying out the Suspension System	11
Installing the Suspension System	12
Power Lift Winch Installation	12
Installing the Main Winch Cable	12
Screw Hook Installation	14
Ceiling Hook Installation	14
Steel Truss Installations	14
Steel Truss Welded Installations	14
Wood Truss Installations	15
Drop Installation	15
Hopper Assembly Procedure	16
Assembly	16
Suspend the Hopper	16
Feeder Pan Assembly	17
Feeder Line Assembly and Suspension	17
Feeder Pan and Tube Assembly Process	17
Assemble and Suspend the Feeder Line	18
Installing Boot Assembly	20
CPF Control Pan	21
Auger Installation	22
Auger Connector Installation	23
Alternative Auger Connection - Auger Brazing	24
Anti-Roost Installation	25

Contents - continued

Topic	Page
Mid-Line Control	28
Wiring	30
Wiring Notes	30
CPF Feeding System with 34574 Time Control	31
Sensor Plus™ Internal Wiring	32
Feeder Management and Operation	33
Initial Start-up of the Feeding System	33
General Operation of the CPF Feeding system	33
Mid-Line Control Pans	34
Controlling the Feeders (optional equipment)	34
Electro-guard Operation	35
Optional Slide Shut-Off	35
Optional MODEL G Plus Pan Extension	35
Maintenance	36
Floor Feeding System Maintenance	36
Gear Head Maintenance	36
Mechanical Switch Adjustment procedure for Control Pans	37
SENSOR PLUS™ Sensor Switch Adjustment for Control Pans	37
Feeder Line	37
Power Lift Winch Maintenance	38
Agri-Timer	38
Parts Listing	40
150# Hopper Components	40
Hopper Mount Bracket (Optional)	41
Boot Assembly Part No. 34824	41
Miscellaneous Components	42
Feeder Line Components	43
Model C2 Plus Feeder Pan Assemblies	44
Model C2 Plus Shallow Feeder Pan Assemblies	45
Model G Plus Feeder Pan Assemblies	46
Model G Plus Shallow Feeder Pan Assemblies	47
Mechanical Mid-Line Control	48
SENSOR PLUS MidLine Control	50
Power Unit and Driver Assemblies	51
Model G Plus Pan Extension (Optional)	52
47687 Power Winch	52
Miscellaneous Suspension Components	53

About This Manual

The intent of this manual is to help you in two ways. One is to follow step-by-step in the order of assembly of your product. The other way is for easy reference if you have questions in a particular area.

Important: Read **ALL** instructions carefully before starting construction.

Important: Pay particular attention to all **SAFETY** information.

- *Metric measurements are shown in millimeters and in brackets, unless otherwise specified. “ ” equals inches and “ ’ ” equals feet in English measurements.*

Examples:

1" [25.4]

4' [1 219]

- Optional equipment contains necessary instructions for assembly or operation.
- Very small numbers near an illustration (*i.e.*, 1257-48) are identification of the graphic, not a part number.

Safety Information

Caution, Warning and Danger Decals have been placed on the equipment to warn of potentially dangerous situations. Care should be taken to keep this information intact and easy to read at all times. Replace missing or damaged safety decals immediately.

Using the equipment for purposes other than specified in this manual may cause personal injury and/or damage to the equipment.

Safety–Alert Symbol



This is a safety–alert symbol. When you see this symbol on your equipment, be alert to the potential for personal injury. This equipment is designed to be installed and operated as safely as possible...however, hazards do exist.

Understanding Signal Words

Signal words are used in conjunction with the safety–alert symbol to identify the severity of the warning.



DANGER indicates an imminently hazardous situation which, if not avoided, **WILL** result in death or serious injury.



WARNING indicates a potentially hazardous situation which, if not avoided, **COULD** result in death or serious injury.



CAUTION indicates a hazardous situation which, if not avoided, **MAY** result in minor or moderate injury.

Safety Instructions

Follow Safety Instructions

Carefully read all safety messages in this manual and on your equipment safety signs. Follow recommended precautions and safe operating practices.

Keep safety signs in good condition. Replace missing or damaged safety signs.

Decal Descriptions

DANGER: Moving Auger

This decal is placed on the Panel Weldment.

Severe personal injury will result, if the electrical power is not disconnected, prior to servicing the equipment.

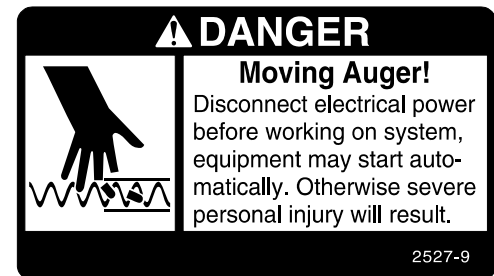

DANGER: Electrical Hazard

Disconnect electrical power before inspecting or servicing equipment unless maintenance instructions specifically state otherwise.

Ground all electrical equipment for safety.

All electrical wiring must be done by a qualified electrician in accordance with local and national electric codes.

Ground all non-current carrying metal parts to guard against electrical shock.

With the exception of motor overload protection, electrical disconnects and over current protection are not supplied with the equipment.

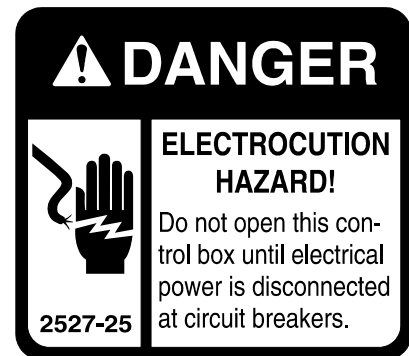

CAUTION:

Use caution when working with the Auger—springing Auger may cause personal injury.

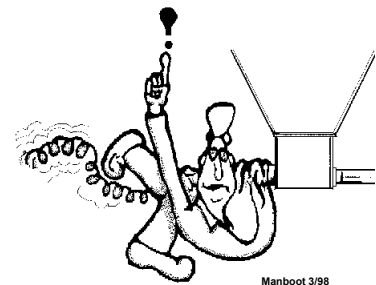

General

Support Information

The Chore-Time Circulating Pan Feeder (CPF) Feeding System is designed to feed poultry types. Using this equipment for any other purpose or in a way not within the operating recommendations specified in this manual will void the warranty and may cause personal injury.

This manual is designed to provide comprehensive planning and installation information. The Table of Contents provides a convenient overview of the information in this manual.

Manufacturers Recommendations: Birds per Pan

Type	Max weight and/or weeks of age	Feeders	Number of birds/pan
Broiler	4.5lbs/2kg.	Revolution 12, Models C2 Plus, C2Plus S, C, H2, H2 Plus	60 - 90
Broiler	7lbs/3.1kg	Revolution 8, C2 Plus, C2 Plus S, G Plus, G Plus S, C, H2, H2 Plus	55 - 75
Broiler	9lbs/4.0kg	Revolution 8, G Plus, G Plus S	45 - 65
Broiler Breeder Pullet – rearing	0 – 18 weeks	C2 Plus (Breeder), C2 Plus S (Breeder)	14 - 15
Broiler Breeder Pullet – rearing	0 – 18 weeks Hi-Yield	C2 Plus (Breeder), C2 Plus S (Breeder)	12-14
Broiler Breeder Male – rearing	0 -- 18 weeks	C2 Plus (Breeder), C2 Plus S (Breeder), G Plus (Breeder), G Plus s (Breeder)	11-13
Broiler Breeder Layer	17 + weeks	C2 Plus (Breeder), C2 Plus S (Breeder)	13 - 14
Broiler Breeder Layer	17 + weeks Hi-Yield	C2 Plus (Breeder), C2 Plus S (Breeder)	12 - 13
Broiler Breeder Male	17 + weeks	G Plus (Breeder), G Plus S (Breeder)	8-10
Commercial Layer Pullet – rearing	0 – 20 weeks	Revolution 12, C2Plus, H2, H2 Plus	40-60
Commercial Layer	18 + weeks	Revolution 12, C2 Plus, C, H2, H2 Plus	30 - 40
Turkey Poult	0 – 5 weeks	Revolution 8, H2 Plus, H2, G Plus, G Plus S	60 - 65
Turkey Poult	0 – 10 weeks	Revolution 8, G Plus, H2 Plus, H2	40 - 50
Turkey Female	5 + weeks	ATF, ATF Plus	60
Turkey Male	5 + weeks	ATF Plus	40 - 50
Ducks	0 – 3 weeks	G Plus, G Plus S	60 - 70
Ducks	4 – 8 weeks	G Plus, G Plus S	50 - 60

***Notice:** Please be advised that the maximum number of birds that may be successfully produced per feed pan may vary based upon such factors as climate, housing type or style, bird breeds, genetic factors of the birds at issue, grower management practices, etc. All other environmental and management circumstances, such as proper bird density per house, access to adequate nutrients in feed, access to adequate water supply, proper ventilation, adequate health care for the birds, and other similar factors, must meet industry standards and recommendations, if any, of applicable bird breeder companies.

*** NOTICE:** The above Manufacturer's recommendations do not constitute a product warranty and are in no way to be considered as a guarantee of performance for poultry production. In addition, the above information in no way alters or revises the terms and conditions of any applicable Chore-Time manufacturer's warranty.

Planning the System

Carefully planning the system prior to beginning the installation will save time and effort. Refer to the FLEX-AUGER[®] Fill System Manual for fill system installation information and specifications.

- Determine the number of birds in the house.
- Determine the number of feeder pans required based on the figures shown in “**Manufacturers Recommendations: Birds per Pan**” on page 8.
- Determine the number of feeder loops required based on house width.
 - 42’ and under = 1 loop
 - 42’ to 60’ = 2 loops
- Divide the total number of pans required in the house by the number of feeder loops. The base system does not include feeder pans between the elbows.
- Determine the length of the feeder loop.
 - House length - 20 = feeder loop straight line length.

Note: For half house brooding applications, it is recommended to use 2 feeder loops as shown in Figure 1. This allows one feeder loop to be used during brooding and both for grow-out.

Find the desired length and order quantity of 2.
 $(\text{House length} - 30)/2 = \text{each feeder loop straight line length.}$

- Select the feeder tube/hole model which comes close to the number of pans per line and length of feeder.

9’ x 4 hole	12’ x 3 hole
10’ x 3 hole	12’ x 4 hole
10’ x 4 hole	12’ x 5 hole
- **Optional:** Feeder pans can be added between feeder loop elbows for additional feeder space if desired. The 4-12’/no hole tubes should be deducted and add 4-9’, 10’ or 12’ tubes with holes. The length of the added tubes will be determined by the feeder loop width and the number of additional feeder pans required. (One of the tubes on each end of the loop may need to be shortened to obtain the desired loop width.)

The diagram in **Figure 1**, shows a house with two CPF feeder loops. The line lengths specified for determining power unit placement refer to the distance between the elbows. However, the total system length = line length X 2, plus the elbows (including the tubes between the elbows).

The *loop* shows the recommended placement of the Power Units, Hoppers, Control Unit, and Weigh Bin.

For line lengths up to 300’ (91.4 m), two (2) power units are recommended. The power units should be evenly spaced opposite each other.

For line lengths from 301’ to 400’ (91.7 to 121.9 m), three (3) power units are recommended. To determine the proper placement of the power units, add the total length of the system, including 3’ [1m] for each 90 degree end section, and divide by 3. This will give an approximate distance between power units, round up or down to the nearest suspension drop line. These power units should be staggered (two on one side, one on the other side).

For line lengths from 401’ to 500’ (122.2 to 152.4 m), four (4) power units are recommended. To determine the proper placement of the power units, add the total length of the system, including 3’ [1m] for each 90 degree end section, and divide by 4. This will give an approximate distance between power units, round up or down to the nearest suspension drop line.

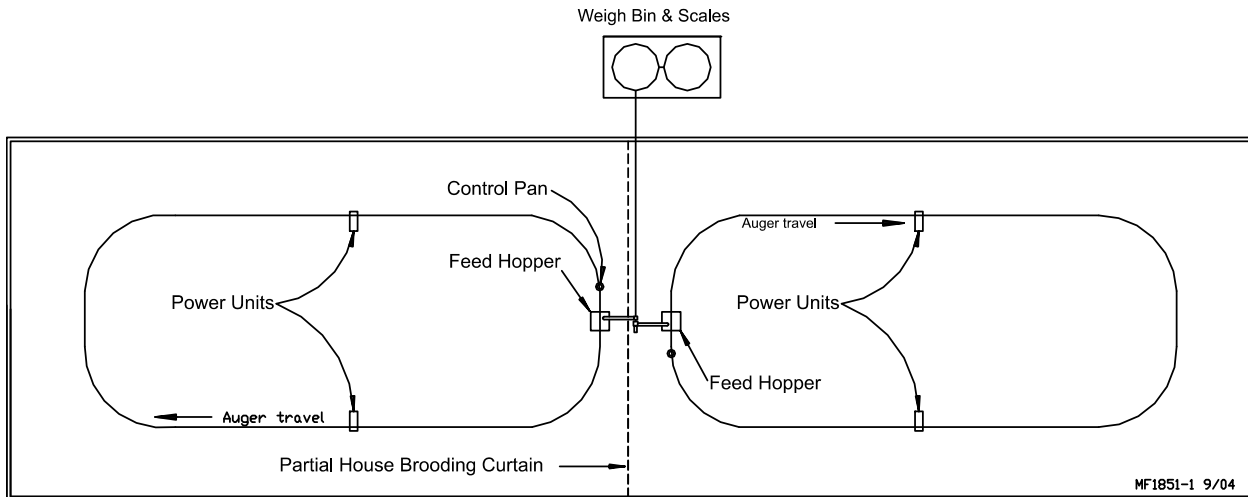

Figure 1. Planning the System

The Control Pan should be located on the side of the feeder loop to be used for partial house brooding. The Control will be installed next to the hopper on the return side of the feeder. The two holes prior to the control must be enlarged.

NOTE: the suspension drop lines are spaced 8' (2.4 m) apart all through the system. Systems using 10' (3 m) or 12' (3.6 m) tubes may be suspended on 10' (3 m) centers. Be sure to support the elbows as shown in this manual.

General Installation Information

Please read the installation instructions in this manual prior to beginning the installation. This manual provides the necessary information on the installation, operation, and maintenance of the Chore-Time feeding equipment you have purchased.

The suspension, hopper assembly, feeder line installation, and anti-roost installation is the same for each system, except where noted otherwise. Please pay particularly close attention to insure proper assembly and installation of the equipment.

The CPF system has been designed to feed broiler and commercial layers on a non-restricted feed schedule. The CPF system is a closed loop system utilizing a drag auger system to deliver feed to the feeder pans. The CPF system uses the Model C2[®] PLUS and Model G[™] PLUS feeder pans installed on 9 through 12 foot feeder tubes. The CPF system utilizes a 61 rpm power unit which operates on 230 volt ac.

The feeder is operated by a Chore-Tronics[®] control. The CPF system utilizes one Mid-Line Control per loop and up to 4 drive units which is determined by the length of the line.

Laying out the Suspension System

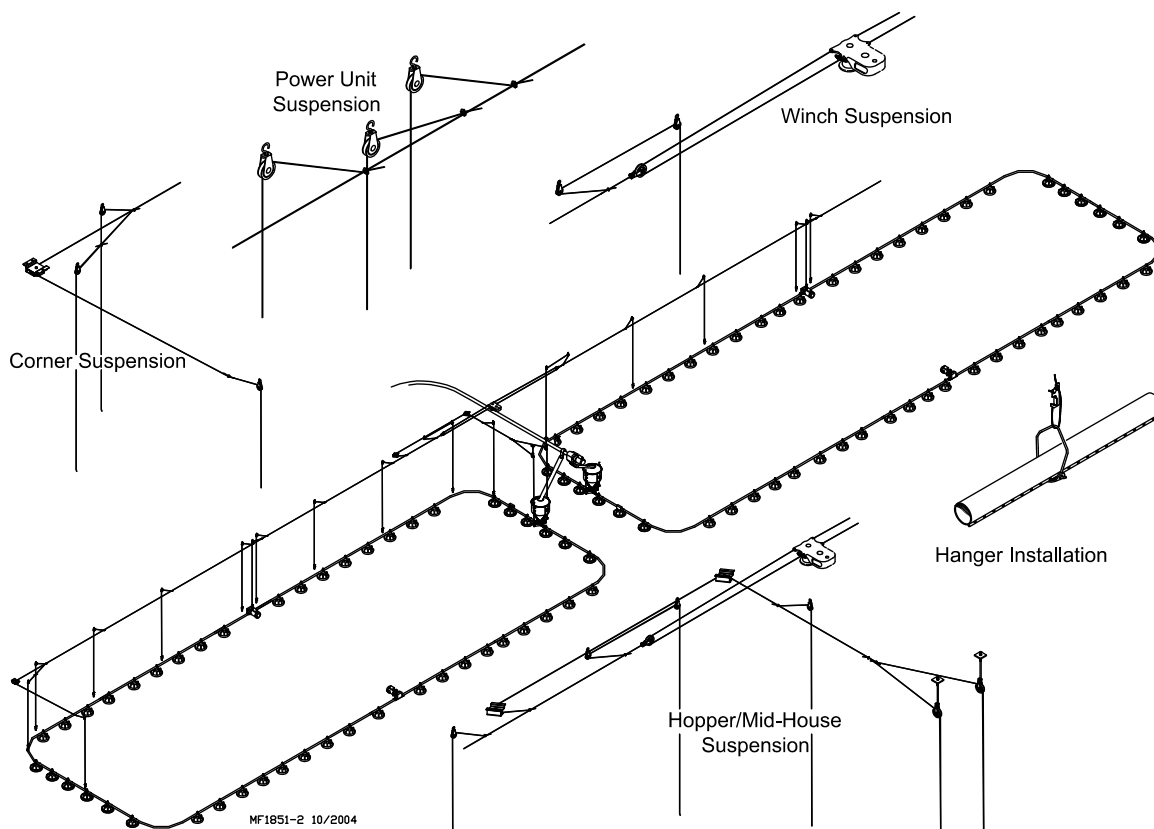

Figure 2. Feeder Suspension.

1. Locate the Power Lift Winch. The Power Lift Winch requires a support that will span, in a wood frame house at least 3 rafters, and in a steel frame house at least 2 rafters.
2. Locate the Power Unit and Feed Hopper. Special support is required at each Power Unit and Feed Hopper location.

Important: Notice the feeder line **MUST BE SUPPORTED DIRECTLY ABOVE THE MOTOR ON THE DRIVE UNIT**. When Steel Hoppers with center suspension are installed the feeder line **MUST BE SUPPORTED WITHIN 1 FOOT (300MM) OF THE HOPPER**. See **page 16** for special plastic hopper suspension. If a Motor or Hopper does not come out directly under a truss, fasten a pulley to a 2x8 (50x200 mm) board or other type of support that will span (2) truss.

- Determine the Drop Location and length. Suspension systems are based on ceiling heights of 14' [4.3 m] with suspension drop points every 8' [2.4 m]. **DO NOT EXCEED 10' [3 m] BETWEEN SUSPENSION DROPS.**
- Determine the location for Screw Hooks. Mark a straight line or use cable to locate Screw Hooks. Use the offset of Screw Hooks where necessary.

Installing the Suspension System

Power Lift Winch Installation

- Bolt the Power Winch, fully assembled, to the Power Lift Winch Support, either a 2" x 8" [50x200 mm] board that will span at least 3 rafters or a 3/8" [9.5 mm] thick steel plate welded to two pieces angle iron that are each long enough to span at least 2 rafters, using 5/16-18 hardware supplied in the Hardware Package. The brake mechanism will extend toward one side.

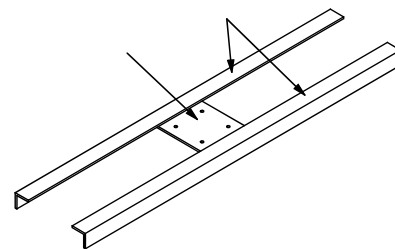

Figure 3. Optional Power Lift Winch support detail

Install a Cable Hook, supplied in Hardware Package, between the mounting bolt and Power Winch frame, as shown in **Figure 4**.

- Attach the Power Lift Winch Support (with the Power Winch secured) to the ceiling at the center of the feeder line. See **Figure 5**. The Power Lift Winch Support must be parallel to the feeder line and must span at least 3 rafters in a wood frame house and 2 rafters in a steel frame house.

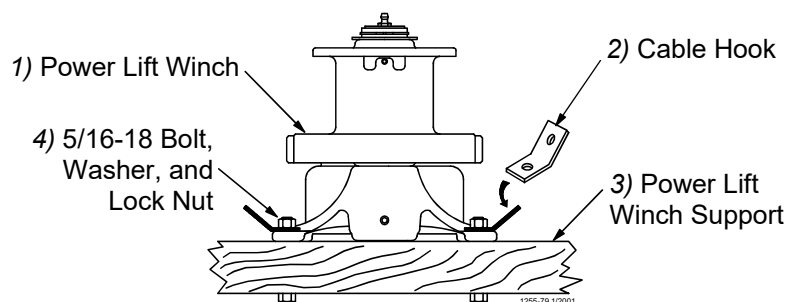

Figure 4. Assembling the Power Winch to the Rafters

If the hopper is located at the center of the feeder line, locate the Power Winch a few feet offset from the center of the feeder line. However, the Winch Drum must be directly in line with where the main cable is to be installed.

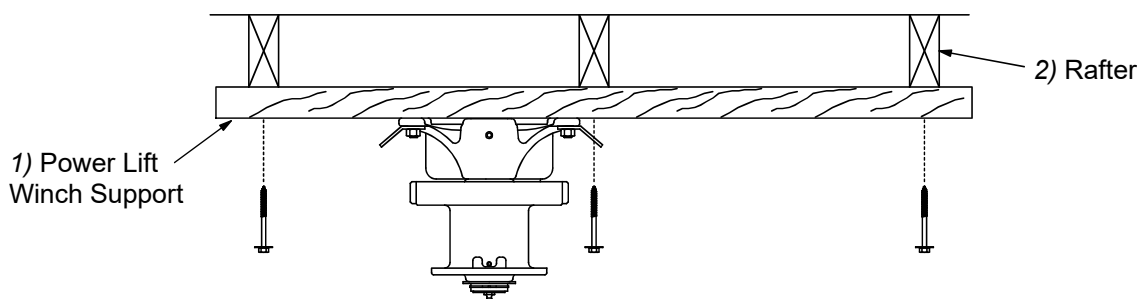

Figure 5. Mounting the Power Lift Winch and Support to the Rafters

Installing the Main Winch Cable

The Suspension Systems are based on ceiling heights of 14' [4.3 m] with Suspension Drop points every 8' [2.4 m]. **DO NOT EXCEED 10' [3 m] BETWEEN SUSPENSION DROPS.** Refer to suspension section in this manual for installation details.

Adequate overhead structure must be provided to support the weight of the feeders, hoppers, power units, etc.

IMPORTANT: Special support is required at each Hopper location.

•Power Unit Locations: **The Feeder Line must be supported within 3' [.9 m] of the Power Unit.** This is in addition to the required Power Unit suspension. If the Control Pan or Steel Hopper does not come out directly under a truss, fasten a pulley to a 2" x 8" [50 x 200 mm] board or steel angle that will span 2 trusses and is capable of supporting 300 lbs [136 kg] for the Hopper and 75 lbs [34 kg] for the Control Pan.

•Feed Hopper Locations: When Steel Hoppers with center suspension are used **the Feeder Line must be supported within 1' [30 cm] of the Feed Hopper.** See page 16 for special **Plastic Hopper Suspension.** This is in addition to the required Feeder Hopper suspension. After determining the type of suspension system required, decide where the Feeder Line is to be installed. Mark a straight line on the ceiling or rafters the full length of the Feeder Line. Use a string, chalk line, or the winch cable, temporarily attached with staples, to mark the line. Center the line directly over where the Feeder Line is to be installed.

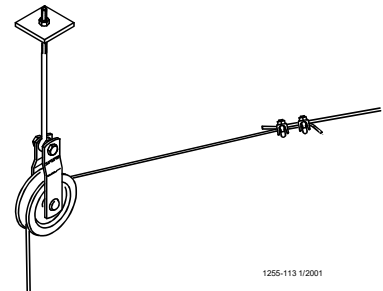

Figure 6. Full Line Suspension Kit

- Extend the 3/16" [5 mm] Main Winch Cable the full length of the feeder line. Attach the cable temporarily to the ceiling with nails, staples, or some type of fasteners. **Figure 7.** shows a double back arrangement.

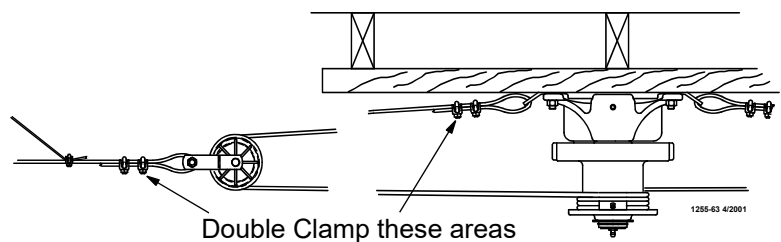

Figure 7. Double back arrangement for feed lines over 350' [107 m]

- Route the cable through the Winch Drum Relief located near the bottom of the drum. Tighten the set screw to anchor the cable to the drum. See **Figure 8.**

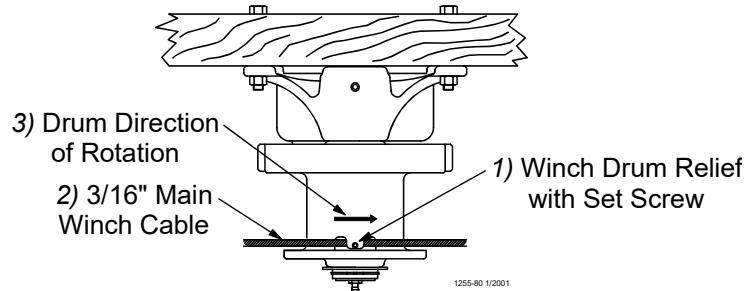

Figure 8. Attaching the Cable to the Power Winch

- Turn the winch drum one full revolution. Guide the cable against the flange at the bottom of the winch drum. The cable must not wrap over itself on the drum, but should be wrapped as close as possible to each previous wrap. See **Figure 9.**

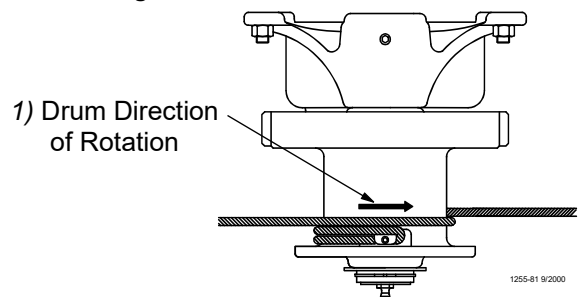

Figure 9. Power Winch Drum Rotation

Screw Hook Installation

The recommended distance between the drops is 8' [2.4 m] on center. Do not exceed 10' [3 m] spacing on drop lines.

If the distance raised is greater than the distance between the drop spacings, offset the hooks 3" [7.6 cm] to each side of the line to prevent the cable clamps from catching the pulleys. See **Figure 10**.

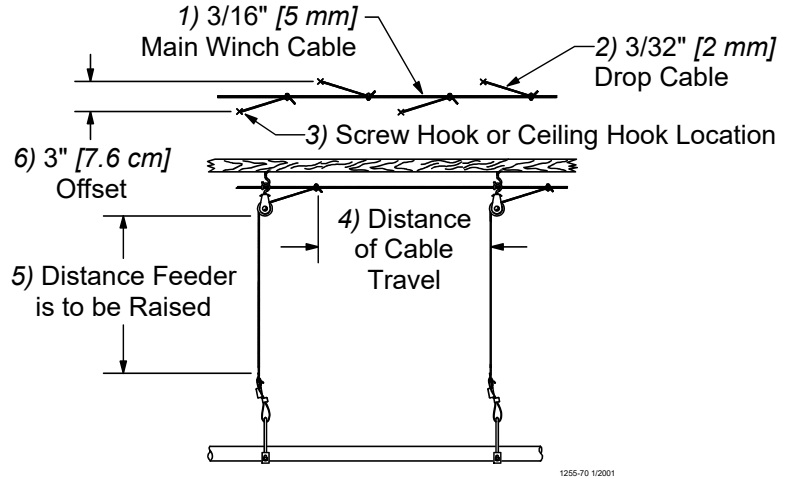

Figure 10. Drop Line Off Set Detail

Screw the hook into the truss the full length of the threads to prevent bending.

The openings of the screw hooks must be pointed away from the direction of travel when the Power Winch raises the feeder line. See **Figure 11**.

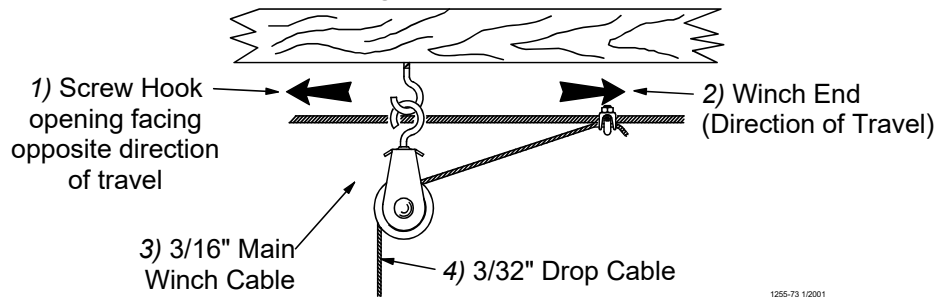
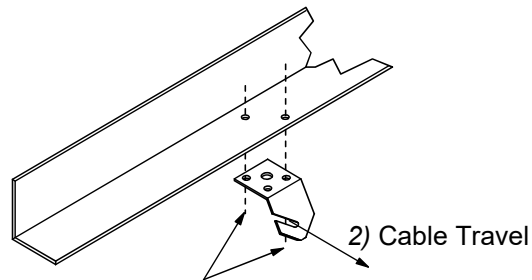

Figure 11. Screw Hook Installation

Ceiling Hook Installation

The ceiling hook may be used in a variety of installations. Depending on your ceiling or rafter type, install the Ceiling Hooks as shown.

Steel Truss Installations



1) Secure Ceiling Hook to truss using self-drilling screws through opposite holes

Figure 12. Steel Truss Ceiling Bracket Installation

Steel Truss Welded Installations

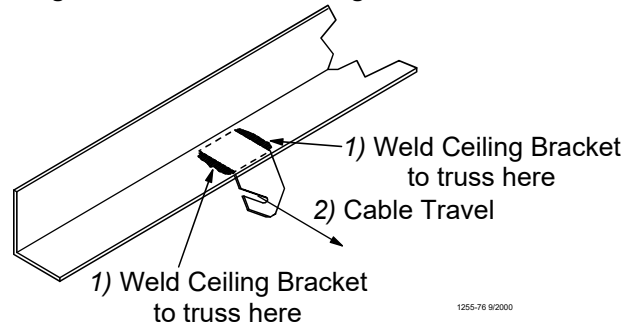

Figure 13. Welded Steel Truss Ceiling Bracket Installation

Wood Truss Installations

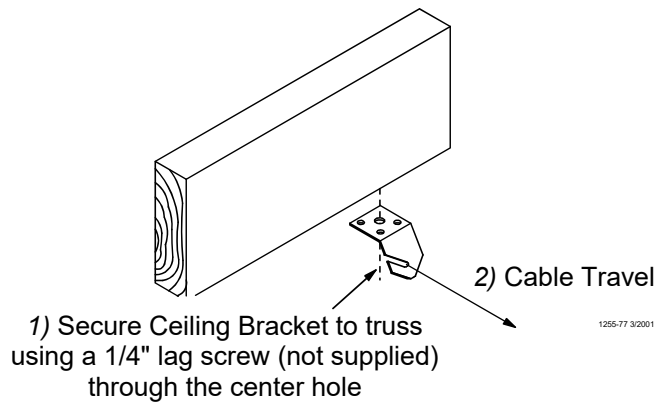

Figure 14. Wood Truss Ceiling Bracket Installation

6. After securing the Ceiling Hook to the truss, slide the hook of a Swivel Pulley into the slot, as shown in **Figure 15**.

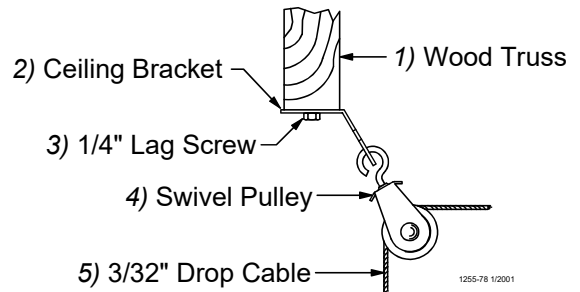

Figure 15. Pulley Installation

Drop Installation

Refer to **Figure 10**. on page 14.

1. Attach a 3004 Pulley to each hook.
2. Thread the end of the 3/32" or 1/8" cable through the pulley toward the winch. Clamp this end to the 3/16" winch cable about 6" [150 mm] from the last pulley, using a 3/16" cable clamp. See applicable figure; **Figure 11** or **Figure 15**.
3. Allow enough cable length for installation of the Adjustment Leveler.

Sufficient cable is included to provide "throwbacks" on drops located beneath and near the winch. **Figure 16** shows a "throwback" cable arrangement.

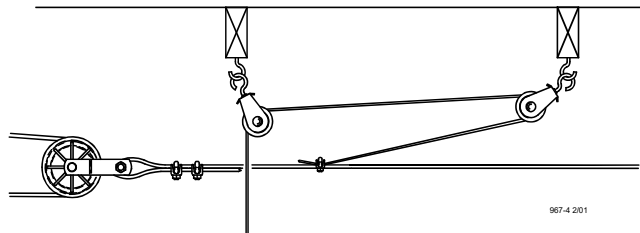

Figure 16. "Throwback" cable arrangement

4. **Begin installing suspension drops at the winch and proceed to the ends of the feeder line.**
Keep the main cable tight between drops. It may be necessary to hang a weight on the end of the cable to maintain tension on the line.

Hopper Assembly Procedure

The 150 lb. Hopper Assembly is **NOT** designed for **single-point suspension**. The upper cross brace is designed for supporting the drop tube **ONLY**. This Hopper Assembly is to have **Two-point** suspension as stated.

Assembly

1. Assemble the 1/4-20 x 1-1/2" bolt to the brace with two 1/4-20 nuts. One nut should be assembled under the brace with the other on top. This bolt is to provide a place for the tube support assembly chain to be hooked. **See Figure 17.**
2. Assemble the 150 lb. hopper halves and brace as shown in **Figure 17**, using #14 x 5/8" screws (supplied in hardware package).
3. Assemble suspension angles and suspension braces around feeder line boot (single or twin), using 1/4-20 x 1/2" Hex bolts and nuts (supplied in hardware package). **See Figure 18.**

Note: The larger holes on the ends of the suspension angles need to be on the upper side of the assembly.

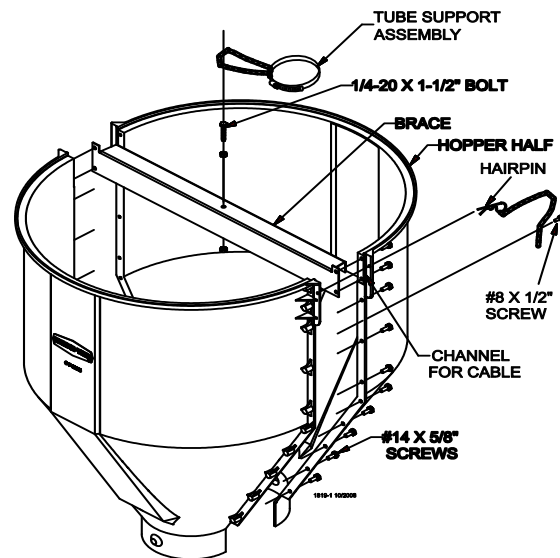

Figure 17.

4. Assemble the twist lock collar to the top of the feeder line boot (single or twin) using 1/4-20 x 1/2" bolts and lock nuts (supplied in hardware package). **See Figure 18**
5. Assemble the adjustment brackets to the suspension angles with 5/16-18 x 3/4" bolts and nuts (supplied in hardware package).
6. Two cable assemblies (cable with a sleeve clamp and a 5/32 thimble) are supplied with the suspension kit to support the hopper. Attach the cable assemblies to the adjustment brackets using the top holes of the adjustment brackets. **See Figure 18.**

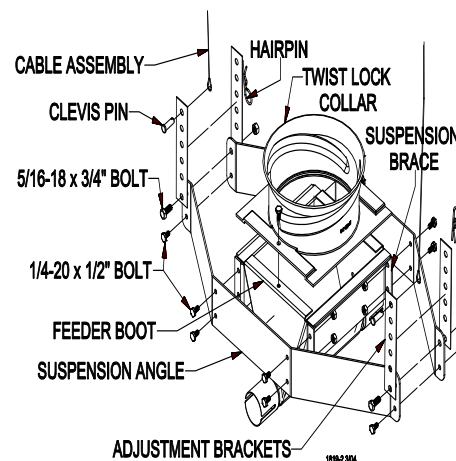

Figure 18.

7. Install two pulleys to either a 2" x 8" [50x200 mm] board that will span at least 3 rafters or a 3/8" [9.5 mm] thick steel plate welded to two pieces of angle iron that are long enough to span at least 2 rafters. Install the pulleys directly above the feeder line where the hopper is to be located. The pulleys should be spaced 22" apart (11" from the center of the hopper in both directions). **See Figure 19.**

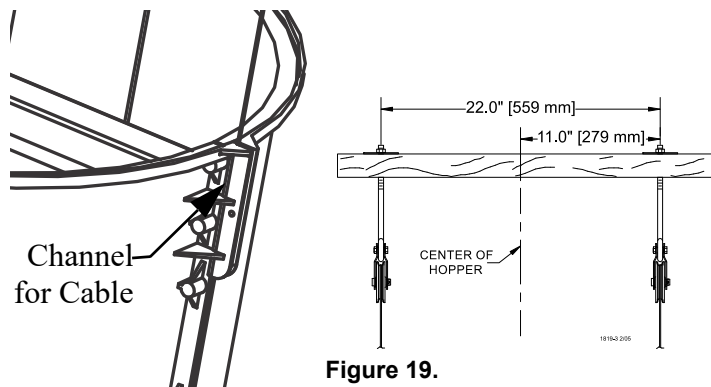

Figure 19.

Suspend the Hopper

1. Attach the boot to the feeder line.
2. Route the two cable assemblies up and around the pulleys.
3. Level the boot with the feed line and clamp the cables to the main cable using 1 cable clamp per cable assembly.
4. Place the hopper on top of the twist lock collar and rotate the hopper 90 degrees into position.

Make sure the cables lay in the channels on the sides of the hopper for support.

Feeder Pan Assembly

All feeders assemble in the same manor. Refer to **Figure 20** below. Slide the Support Cone, the Adjustment Cone, and the Grill together as shown in **Figure 20**. Hook the loop of the Grill to the tab of the Feeder Pan. Rotate the Feeder Pan over on the top of the Grill and Cones. Seat the Feeder Pan in the ring of the Grill. With the Feeder Pan fully seated rotate the pan clockwise to lock in place. Assemble the remaining Feeders.

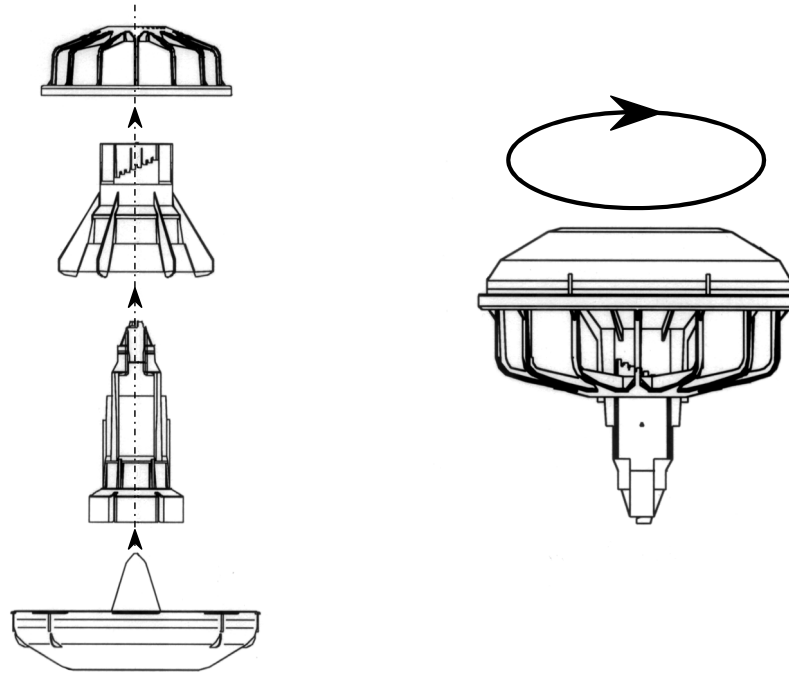

Figure 20. Assembling the Feeder Pan

Feeder Line Assembly and Suspension

Feeder Pan and Tube Assembly Process

- Slide one Feeder Pan Assembly per hole onto the auger tubes.
IMPORTANT: Install all the feeders on the tubes in the same orientation.
 When sliding the feeders on the tubes, make sure the grill openings are on the same side of the tube.
- Rotate the auger tubes so that the seam is down, this holds the Pan Assemblies in place on the tubes. See **Figure 21**.

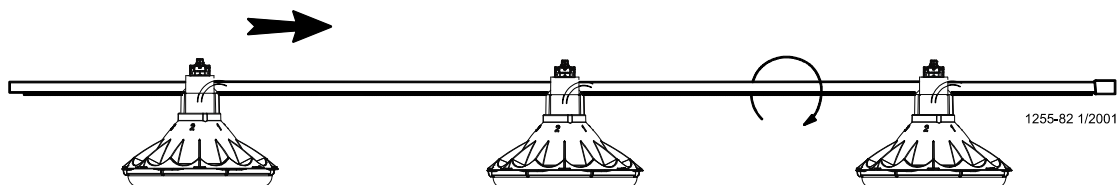

Figure 21. Assemble Feeders on tubes

Assemble and Suspend the Feeder Line

1. The auger tubes and feeders may be laid out end to end in approximately the final location of the line. The **belled end of each tube should be toward the Hopper end of the line**. See **Figure 22**.
2. Connect the individual feeder tubes together by inserting the straight end of one tube as far as possible into the belled end of the next tube. **The last Feeder Tube before the Mid Line Control pan needs to be a Control Tube.**

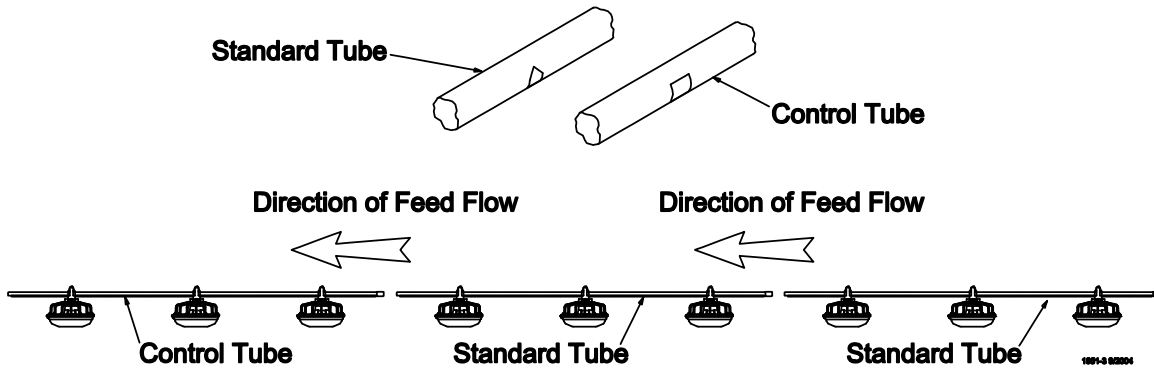

Figure 22. Attaching Feeder Tube Assemblies

3. To achieve total feed drop out all along the system, the Chore-Time Logo should be centered at the crown of the tubes and all the Hangers should be installed as shown in **Figure 23**.

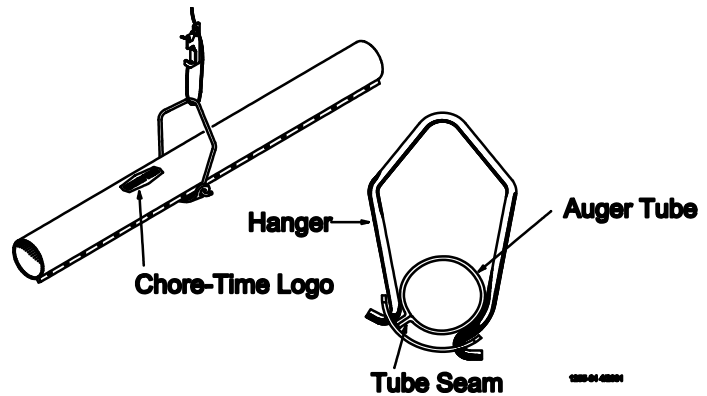

Figure 23. Hanger Installation

4. Place a Tube Clamp Assembly or Clamp/Anti-Roost Bracket at each joint. **Figure 24** shows the standard Clamp and Clamp/Anti-Roost Bracket.

Systems using 9' or 10' tubes require a Clamp/Anti-Roost Bracket at every **fifth** joint.

Systems using 12' tubes require a Clamp/Anti-Roost Bracket at every **fourth** joint. All other joints in the system use the standard Tube Clamp Assembly.

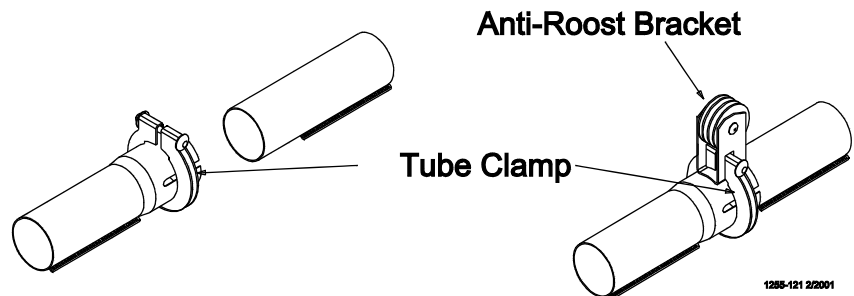

Figure 24. Tube Clamp and Tube Clamp with Anti-Roost Bracket

Continue down the entire length of the feeder line so that every joint is secured with a standard Clamp or Clamp/Anti-Roost Bracket.

Figure 25 shows the proper clamp location on the tube joint. *Do not tighten the clamp at this time.*

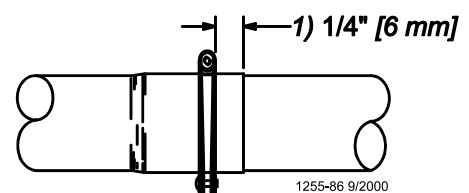

Figure 25. Clamp Installation

5. Install the Hangers on the feed line tube at the 8' [2.4 m] spacings determined by the suspension drop lines. **Figures 23 and 26** show the proper installation of the Hanger Assembly. Make sure the outlet drop hole is downward when the Hangers are installed, otherwise feed will not be allowed to drop into the feeder pan.

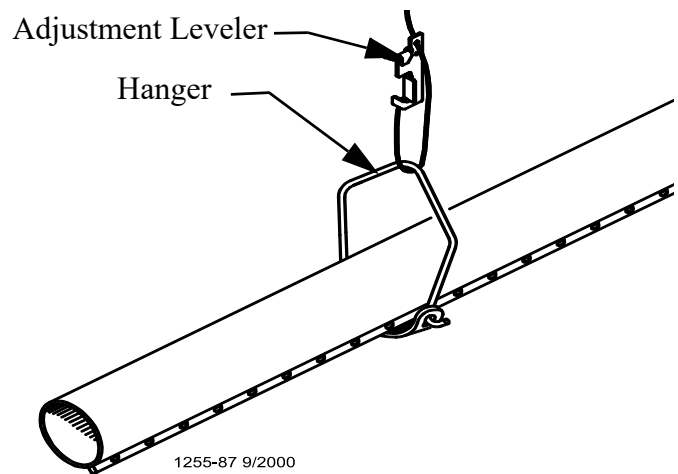

Figure 26. Hanger Installation

6. Install Adjustment Leveler within 6" [152 mm] of feeder line. **Figure 27** shows the proper cable routing around the Adjustment Leveler.
7. Following the installation of all drops, check drop cables before raising feeder line. Cable must be tracking properly on all pulleys before raising the feeder line.
8. Raise the feeder line to a convenient working height.
9. With the feeder line suspended, measure from the floor or ceiling to the auger tubes to level the system.
10. Before tightening each clamp:
 - make sure each tube is level (not sagging, sloping, etc.).
 - make sure straight end of each tube is fully inserted in belled end of next tube.
 - if providing total drop out, tubes should be rotated so that the Chore-Time Logo is on crown of tube.
 - make sure the clamps are located, as shown in **Figure 25**.

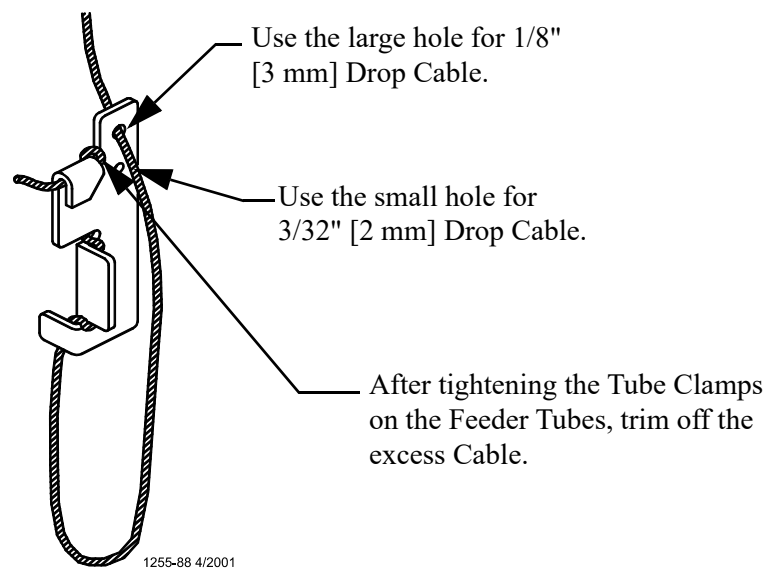

Figure 27. Cable Lock Threading

Finally, tighten the Tube Clamps on the feeder tubes. Clamp the joints securely, but do not crush the tubes. Re-adjust all Adjustment Levelers as needed and trim off excess cable as shown in **Figure 27**.

Installing Boot Assembly

- Beginning at the Boot, assembly the Tube Connector, and Auger Tubes as shown in the appropriate diagram.
Note: The feed tubes should be installed clockwise around the system, starting at the outlet end of one hopper, continuing through the elbows to the incoming end of the other hopper.

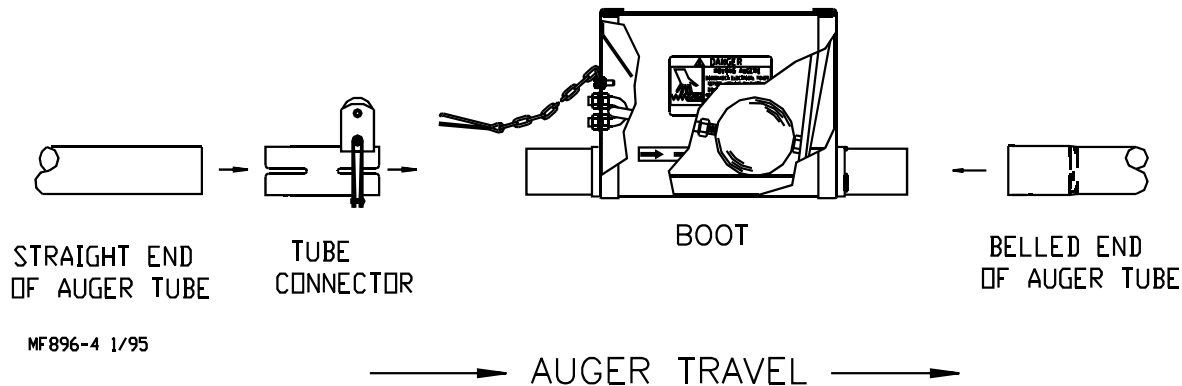

Figure 28. Boot components for Recommended Hopper Location (View Standing inside Loop)

- Continue assembling the feeder line until a power unit location is reached. See “Planning the System” on page 9. to determine Power Unit locations.

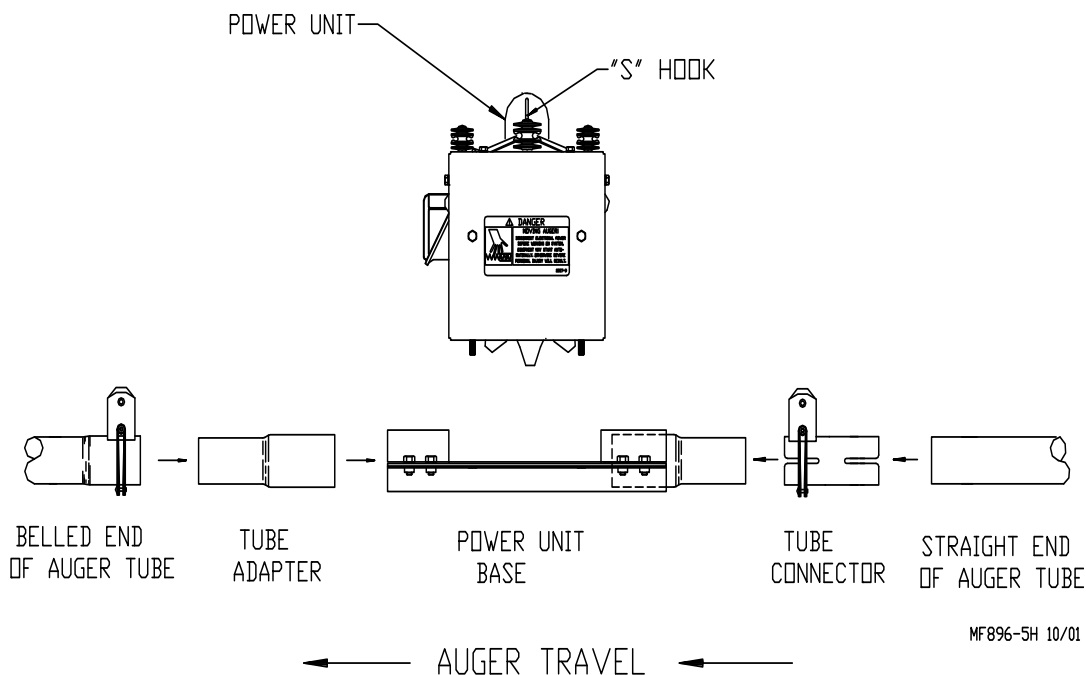
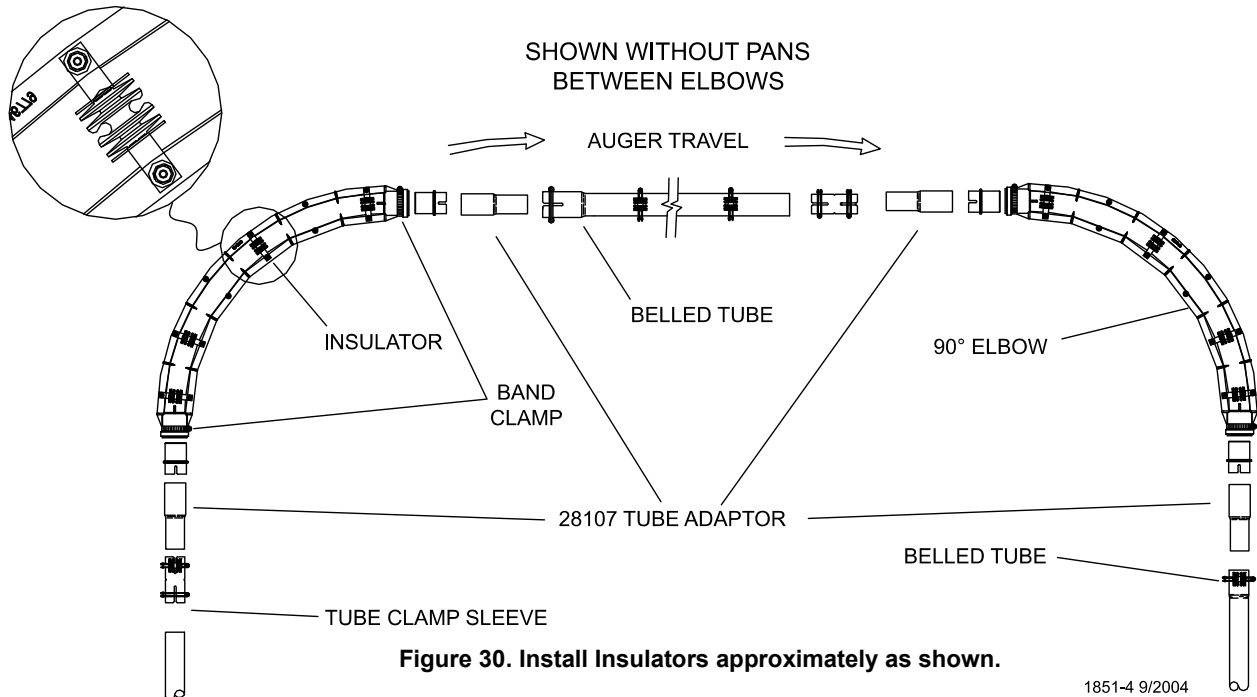

Figure 29. Power Unit Installation (View Standing outside the loop)

- Remove the Power Unit from the Base Connector Weldment and install the Base Connector Weldment, as shown in **Figure 29**.
- Loosen the four bolts on the incoming side of the Power Unit Base.
- Slide the belled end of the Tube Adapter into the incoming side of the Power Unit Base.
- Tighten the Four Bolts to secure the Tube Adapter to the Power Unit Base, see **figure 29**.
- Use a Tube Connector to connect the incoming straight section of auger tube to the Tube Adapter. Secure using a standard Clamp and an Anti-Roost Clamp.
- Loosen the four bolts on the outgoing side of the base Connector Weldment.
- Slide the belled end of the Tube Adapter into the outgoing side of the Power Unit Base.
- Tighten the four bolts to secure the Tube Adapter to the Power Unit Base.
- Insert the belled end of the next tube section over the Tube Adapter, as shown in **Figure 29**. Secure using a Clamp/Anti-Roost Bracket.
- Continue installing auger tubes until the elbows are reached.
- Assemble the elbows and related components as shown in **14**. Temporarily support the elbows until the suspension system is installed.

Note: One of the tubes on each end of the loop may need to be shortened to obtain the desired loop width.



14. Install the remaining auger tubes, Power Unit bases, hopper and elbows the same as the first.
15. Figure 31 shows the preferred location of the service section.
16. Cut the belled end of the auger tube leaving 15" (380 mm) between tubes to install the Service Section. Approximately 4" (100mm) of the Auger to tube seam will need to be cut off to allow the Service Section to be installed.
17. Secure the Service Section Clamps on top using the 1/4-20 hardware supplied. Do not install the Service Section Cover at this time.

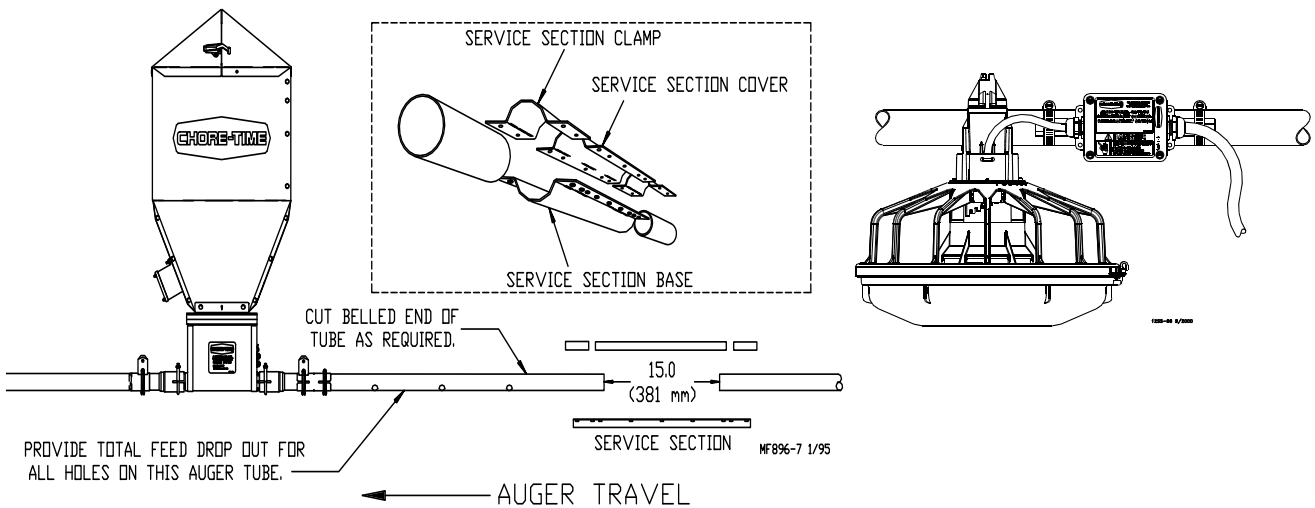

Figure 31. Service Section Installation

CPF Control Pan

The Sensor Plus™ Control uses a Proximity Switch to sense feed and cause the system to start and stop. The Proximity Switch has delay adjustment screws.

The Sensor Plus Control is to be located just prior to the Feed Hopper on the return side of the feeder.

Do not hinder the bird movement around the Intermediate Control pan. Provide adequate lighting so that the birds will not shy away from the Intermediate Control area.

Auger Installation

Note: Use extreme caution when working with the Auger. The Auger is under tension and may spring causing personal injury. Wear protective clothing, gloves, and safety glasses when working with the auger.

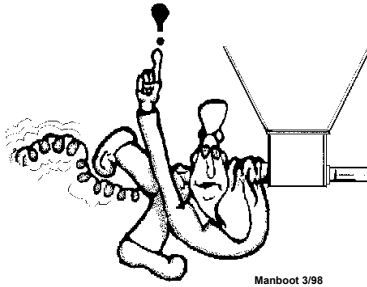

BE CAREFUL WHEN WORKING WITH THE AUGER!

To avoid kinking the auger, be careful not to drop the rolled auger when handling. Inspect the auger carefully as it is installed. Small kinks may be straightened. Large kinks must be removed and the auger brazed back together.

Cut the leading 18" (450 mm) and last 18" (450 mm) off each roll of auger. Also, cut out any other destroyed auger sections and reconnect the auger as specified in the Auger Connector or Auger Brazing section of this manual.

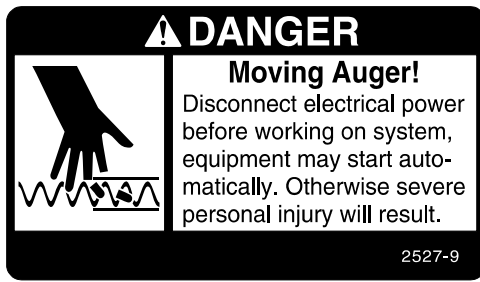

In preparation for the auger installation, complete the following:

- The Power Unit and Driver Assemblies must be removed from the Base Connector Weldment. An Auger Driver must be installed on each Base Connector Weldment. See **Figure 32**.
- The Service Section Cover must be removed to install the Auger.

1. Begin feeding one end of the auger into the auger tubes through the Service Section.

Chore-Time recommends always feeding the auger into the tubes from the outside of the coil (this has a plastic cap on the end of the Auger). This will insure the auger flightings will match.

Push the auger, by hand, to the first Auger Driver. The Auger Driver may then be used to pull the Auger through the tubes. An Auger Driver should be installed at each motor location to aid in pulling the auger around the system. See **Figure 32**.

2. If more than one Auger is to be installed, the tail end of the first Auger and the leading end of the second Auger must be connected with an Auger Connector.

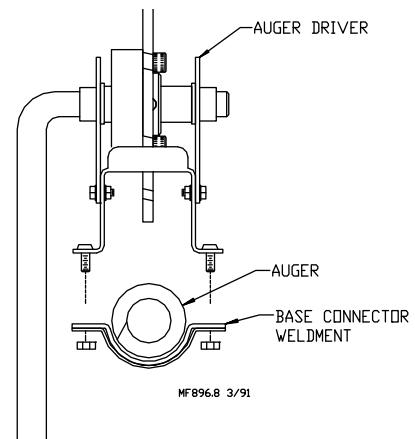
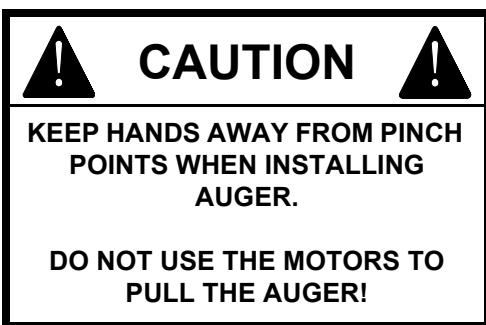

Figure 32. Auger Driver

3. Continue installing the Auger until it reaches the Service Section.
4. Cut excess Auger off the coil, leave enough Auger to work with when stretching and connecting the Auger.
5. Pull on one end of the Auger until the other end moves. Release the Auger and allow it to relax to its free length.
6. Use locking pliers to hold one end of the Auger in place while stretching the Auger. See **Figure 33**.

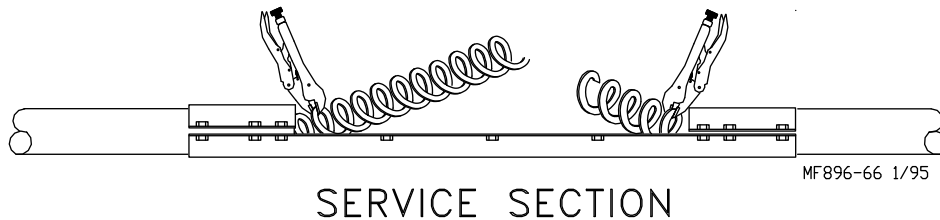

Figure 33. Auger Service Section

7. Determine the amount of stretch required.
The amount of stretch required is 6" per 100' (150 mm per 30 m) of total system length.
For example: If the system has an overall system length of 300' (91.4 m), the required Auger stretch is 18" (460mm).
8. From the relaxed position, stretch the Auger (as determined by step 7, above) by pulling on the loose end.
9. Mark the Auger where it is to be cut.
10. Pull another 18" (450 mm) of Auger and install another set of locking pliers to keep the Auger from springing back into the Auger tube. See **Figure 33**.
11. Cut the Auger at the mark. File the end of the Auger smooth so there are no sharp edges.
Make sure the Auger is not deformed or twisted from cutting. Deformed Auger will not match well with the other end of the Auger and may cause problems passing through Drive Units.

Auger Connector Installation

The Auger Connector is designed to fasten the ends of the CPF Auger together without welding.

Note: This is not to be used with rotating Auger systems.

1. Screw the Auger Connector into one end of the Auger.
2. Untwist the remaining end of the Auger 1-1/2 turns so when it is threaded into the first end of the Auger it will return to its relaxed position. Auger ends must be overlapped **NOT** butted when threaded into the track of the Auger Connector. See **Figure 34**.

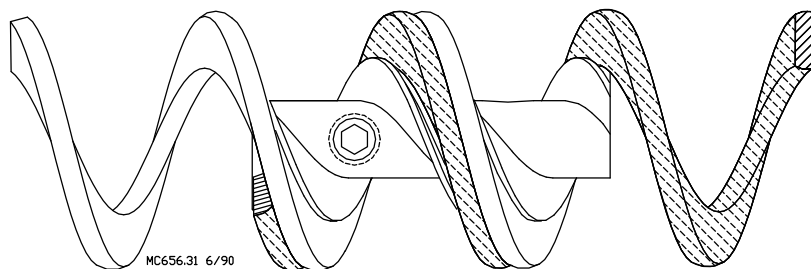

Figure 34. Auger Connector

3. Stretch the Auger and twist the Auger ends together. Both ends of the Auger should be even with the end of the Auger Connector.
4. Tighten each set screw until it touches the Auger, then tighten and additional 3/4 turn **MAXIMUM**.
Be careful not to over tighten the setscrews and deform the Auger. Over tightening the setscrews may cause the Auger to jam up in the power units.
5. File both ends of the Auger so they are the same diameter as the rest of the Auger.

Alternative Auger Connection - Auger Brazing

The feeder Auger may be brazed according to these instructions to obtain a strong joint.

Screw the Auger together about 120 degrees (1/3 turn) and secure in the welding fixture. See **Figure 35**.

Slowly heat the Auger and apply a braze to the **INSIDE** of the Auger. Allow it to cool slightly, then rotate the welding fixture and braze the **OUTSIDE** of the Auger.

The Braze should extend from 1/8" to 1/4" (3 to 6 mm) from the end of each Auger. **DO NOT BRAZE ALL THE WAY TO THE END.** This allows the Auger to flex in either direction as it travels around the elbows without becoming weakened. See **Figure 36**.

Things to Remember:

- To insure a good braze, clean dirt, oil, etc. off both ends of the Auger.
- A bronze, flux coated filler rod is recommended.
- The joint should be smooth and well filled.
- Do not over heat the Auger, apply just enough heat to melt the filler rod.
- Allow the Auger to air cool.
- File all edges smooth
- The outside diameter of the Auger at the braze should not be larger than the rest of the Auger.

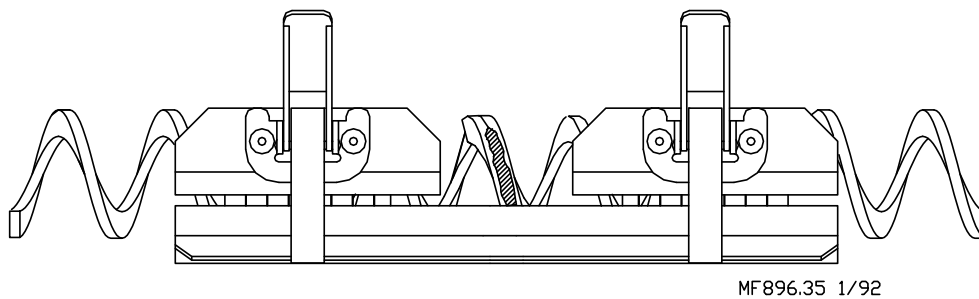

Figure 35. Welding Fixture

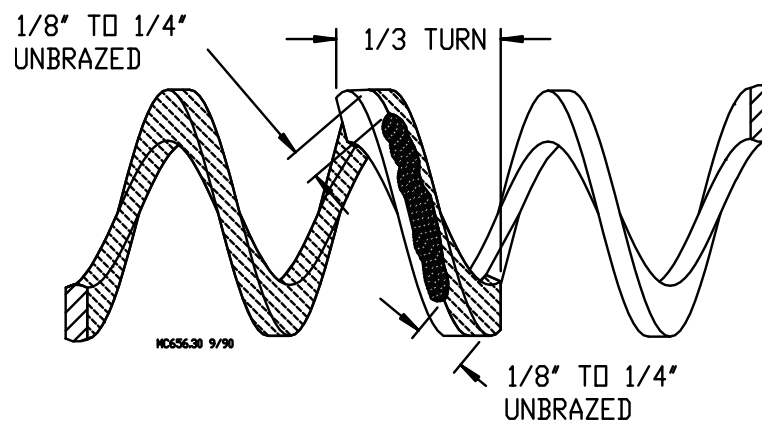
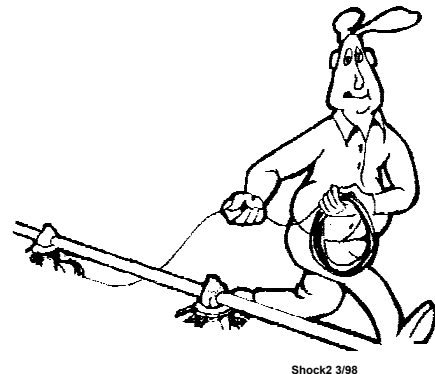

Figure 36. Brazing Area

Anti-Roost Installation

1. Unroll the bulk anti-roost cable. Note: If the cable is unrolled as shown in **Figure 37**, taking 5 loops of the coil with one hand, then changing hands to remove 5 loops as it is unrolled, it will lie flat during installation.



Shock2 3/98
Figure 37. Unrolling the Cable

2. Start at the hopper end of the line and form a loop around the anti-roost bracket. For best results, make a double loop around the anti-roost insulator in the center groove of the insulator and fasten with a 1/16" cable clamp as shown in **Figure 38**.
3. Insert the cable in the insulator on the top of each Grill Support between the hopper and the next anti-roost bracket.

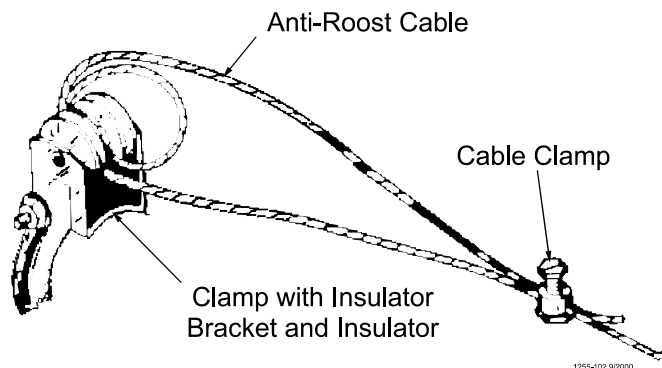

Figure 38. Anti-Roost Cable at the Hopper

4. Attach a spring in the center groove at the second anti-roost bracket and cut the cable at this point. See **Figure 39**.
5. Thread the ends of the cable through the end of the spring. Pull the cable tight so that there is 3/4" to 1" [20 to 25 mm] of stretch in the spring. Clamp the cable to form a loop and cut off any excess. See **Figure 39**.
6. Attach the cable to the insulator. For best results, make a double loop around the anti-roost insulator in the center groove of the insulator and fasten with a 1/16" cable clamp as shown in **Figure 39**.

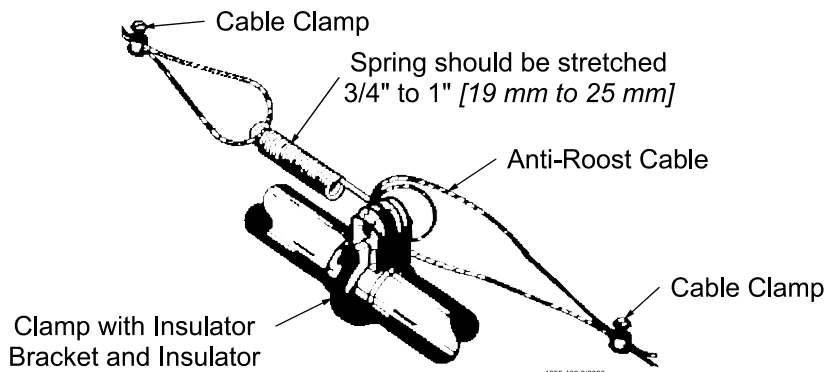

Figure 39. Anti-Roost Cable Intermediate Connection

7. Run the cable to the next Anti-Roost clamp. Attach a spring in the center groove at the Anti-Roost Bracket and cut the cable at this point. The cable should be positioned in the insulator built into the top of each Grill Support along the feeder line.
8. Repeat this installation until the anti-roost cable is installed along the entire feeder line.
9. At the control unit, after clamping the cable to the spring, cut the cable about 8" to 10" [200 to 250 mm] longer than necessary. Feed the end of the cable through the center of the spring, around the first insulator on the control unit, and clamp the cable using the cable clamp supplied with the control unit. See **Figure 40**.
10. Install the wire form on the control unit insulators. Be sure the guard snaps into the retainers molded into the insulators. See **Figure 40**.
11. Anti-Roost clamps must be installed around the elbows, as shown in **Figure 41**.

The Anti-Roost Wire is provided to be used around the elbows. Snap it down in the center groove of the insulators on the elbows. See **Figure 41**.

Install a jumper wire from the shocker cable to the Anti-Roost wire, using a cable clamp, supplied.

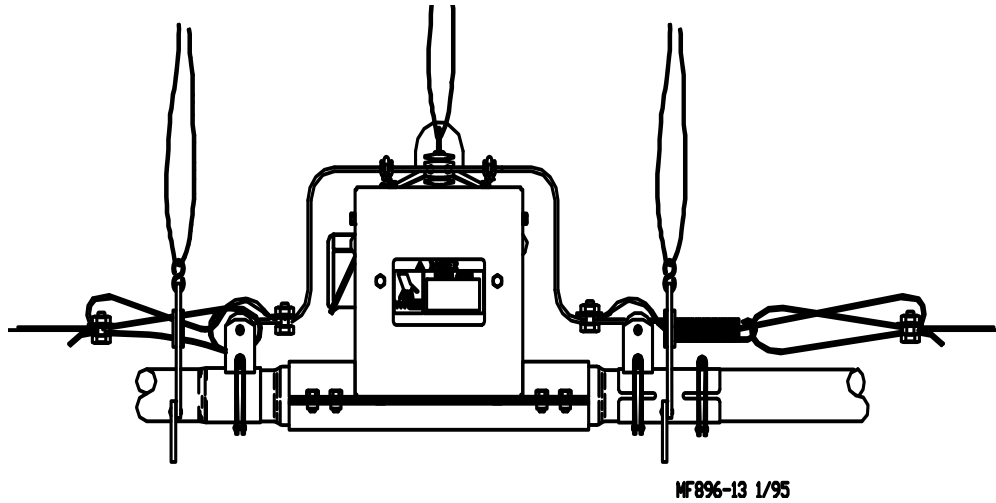

Figure 40. Anti-Roost Installation at the Control Unit

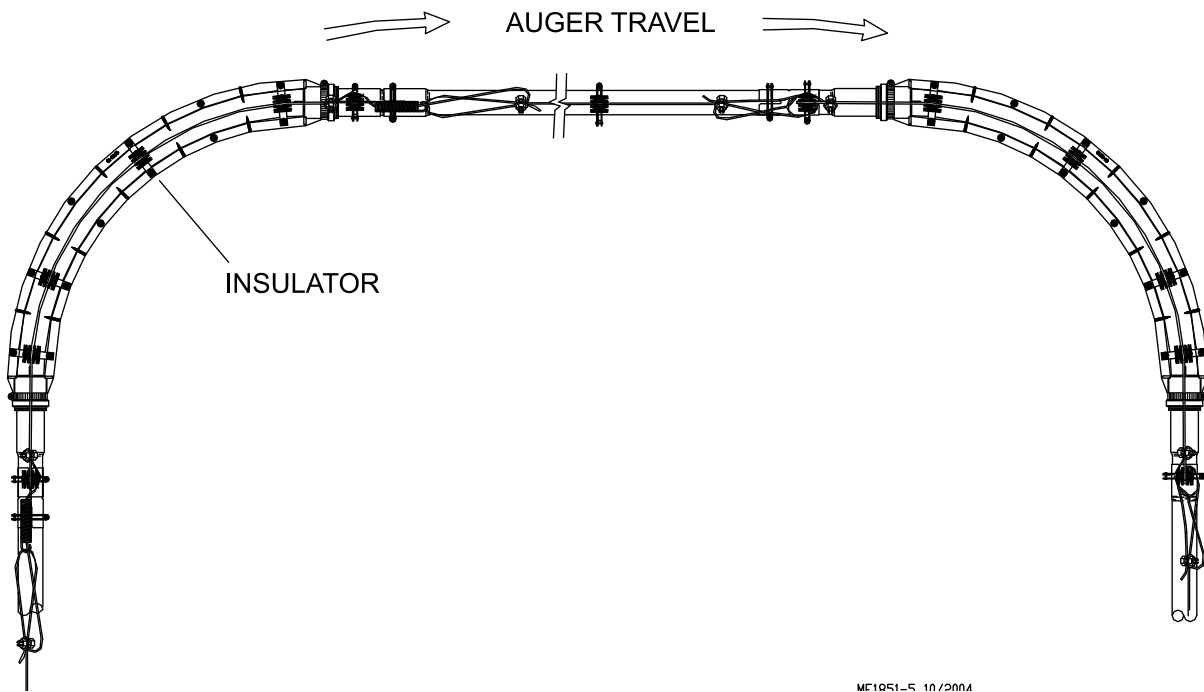

Figure 41. Anti-Roost Installation at the Elbows

12. Continue installing the Anti-Roost cable, spring, etc. similarly around the system.
13. Install the High-Voltage wire from the insulator on one side of the boot to the insulator on the other side of the boot. See Figure 42.

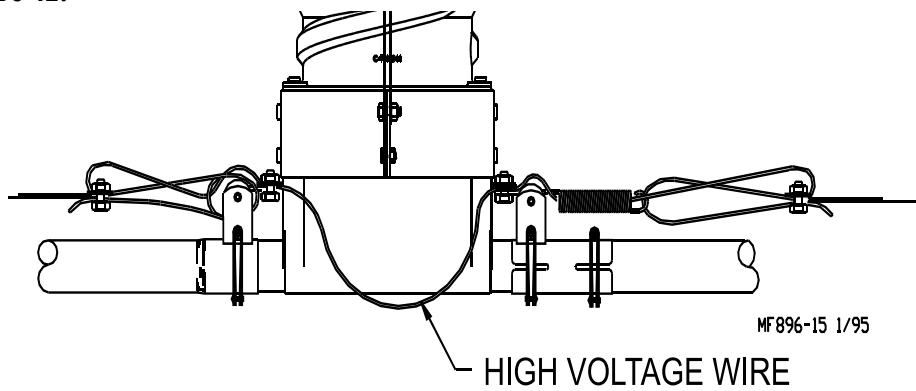

Figure 42. High Voltage Wire installation

14. Install the Line Charger to the side of the feeder tube with two tube clamps, included in the parts package. Connect the charge cable to the Anti-Roost line using the cable clamp supplied. See **Figure 43**. Use only the voltage listed on the Line Charger to operate it.

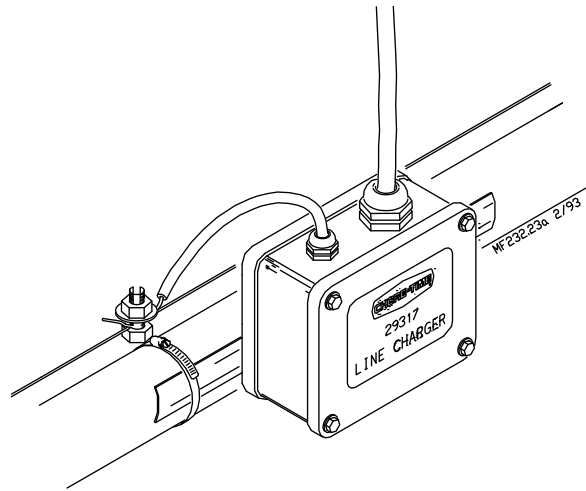
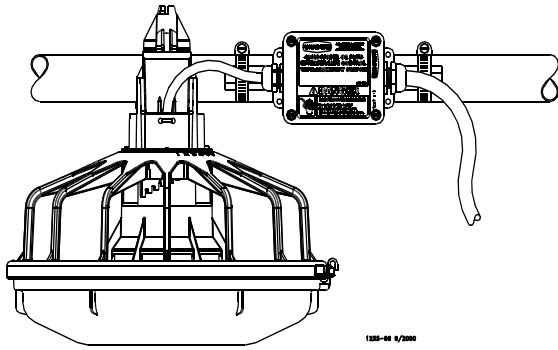

Figure 43. Line Charger Installation

15. The **anti-roost system** *must* be on a **separate electrical circuit**, allowing the system to be disconnected by a **switch near the door**.

Mid-Line Control

Mid-Line Control Pans are available for the CPF Feeder. The Mid-Line Controls are shown below.



Model C2 Plus Mid-Line Control with Sensor Plus Proximity Switch

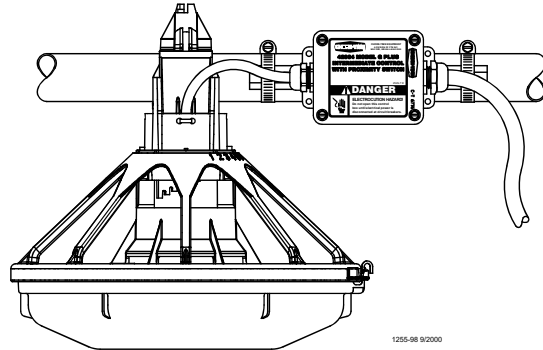

Model G Plus Mid-Line Control with Sensor Plus Proximity Switch

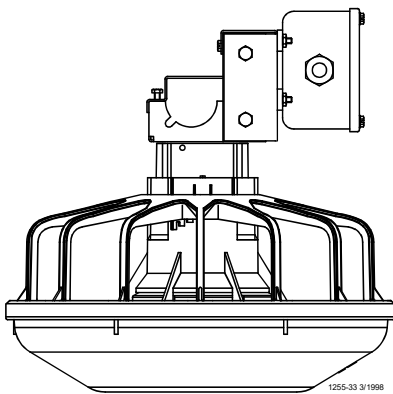

Model C2 Plus Mid-Line Control with Mechanical Switch and Windows

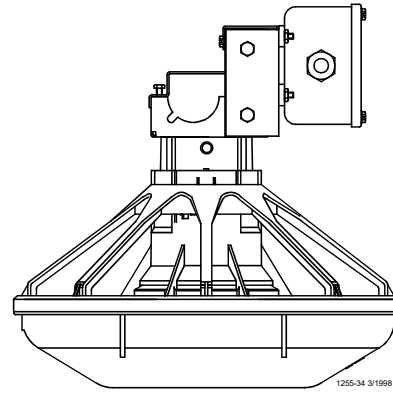

Model G Plus Mid-Line Control with Mechanical Switch and Windows

Figure 44. Mid-Line Controls

The Mid-Line Control makes it possible to operate the feeding system. Chore-Time recommends placing the Mid-Line Control Feeder at least 2 pans away from the Hopper on the return side.

- New Feeder Lines:** Leave one feeder pan assembly off the feeder control tube at the point where the Mid-Line Control needs to be placed. The feeder line can be assembled and suspended before attaching the Mid-Line Control; or the Mid-Line Control may be attached to the feeder tube when the other pans are installed.

Existing Feeder Lines: Cut the Grill Support and remove the feeder pan at the location where the Mid-Line Control will be installed.

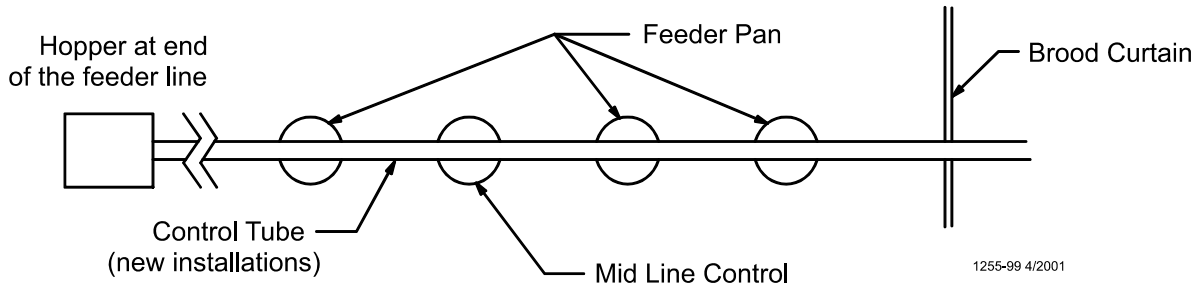

Figure 45. Mid-Line Control Location Diagram

- 2. **New Feeder Lines:** Go to step 3.
Existing Feeder Lines: Enlarge the outlet hole to approximately 1" [2.5 cm] diameter for the Mid-Line Control, plus enlarge (2) outlet holes in front (to the hopper end) of the Mid-Line Control.
 Use unibit to enlarge hole size. Be sure there are no burrs inside the tube to catch the auger.

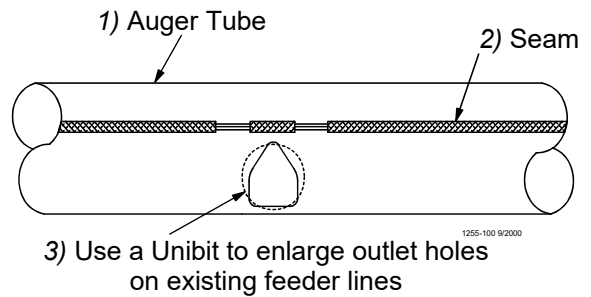

Figure 46. Enlarging Outlet Holes

- 3. Install the Mid-Line Control:
 - Mechanical Switch:**
 - a. Remove the two hex head screws on the control top.
 - b. Lift off the control top.
 - c. Cradle the feeder tube in the control housing. The feeder tube may have to be turned slightly to allow the pan to hang straight.
 - d. Clamp the control in place by inserting tabs on the control top into the slots on the control body. Install and tighten the two hex head screws previously removed.

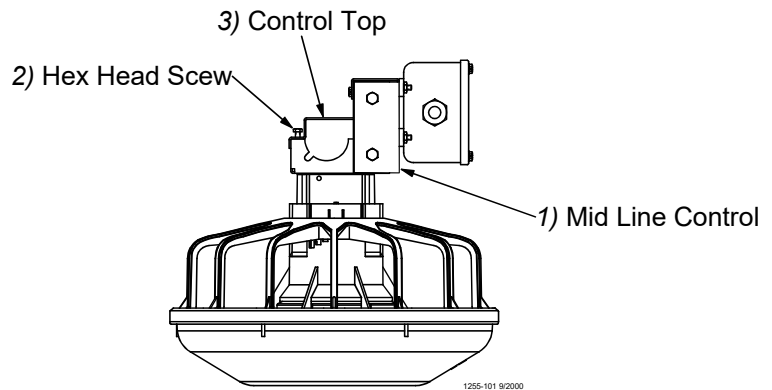

Figure 47. Mid-Line Control Installation

Sensor Plus Switch:

- a. Assemble the Mid-Line Control to the Feeder Tube as shown in **Figure 47**.
- b. Attach the Switch Box Assembly to the Feeder Tube with Hose Clamps as shown in **Figure 47**.

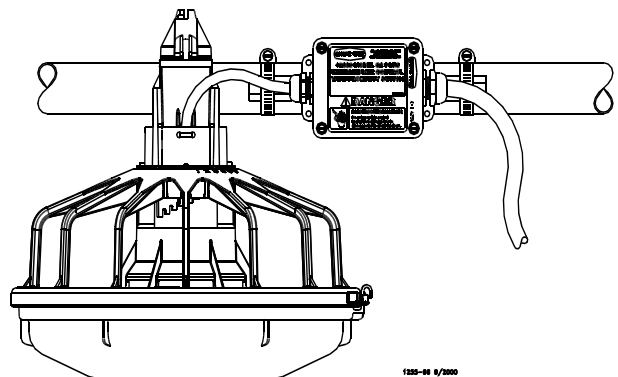

Figure 48. Installing the Sensor Plus Mid-Line Control

- 4. Wire the Mid-Line Control as shown in the wiring diagram section of this manual.

Wiring

Wiring Notes

Disconnect electrical power before inspecting or servicing the equipment, unless the maintenance instructions specifically state otherwise.

Wire the electrical equipment according to the wiring diagrams in this manual.

All field wiring must be done by a qualified electrician, according to local and national codes.

Do not operate the equipment without the covers and guards properly positioned.

Failure to do so may cause personal injury or damage to the equipment. Ground all electrical equipment.

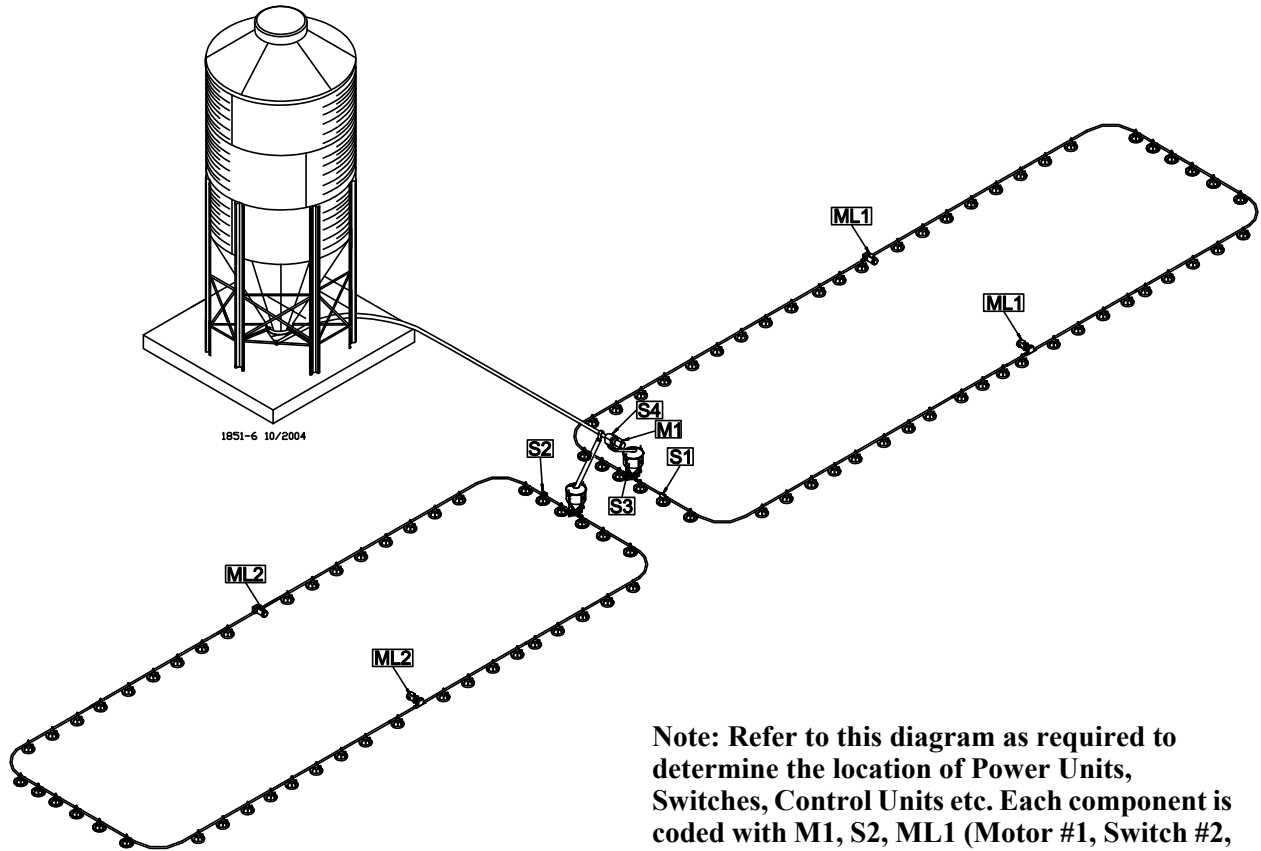

Note: Refer to this diagram as required to determine the location of Power Units, Switches, Control Units etc. Each component is coded with M1, S2, ML1 (Motor #1, Switch #2, Drive Unit #1).

CPF Feeding System with 34574 Time Control

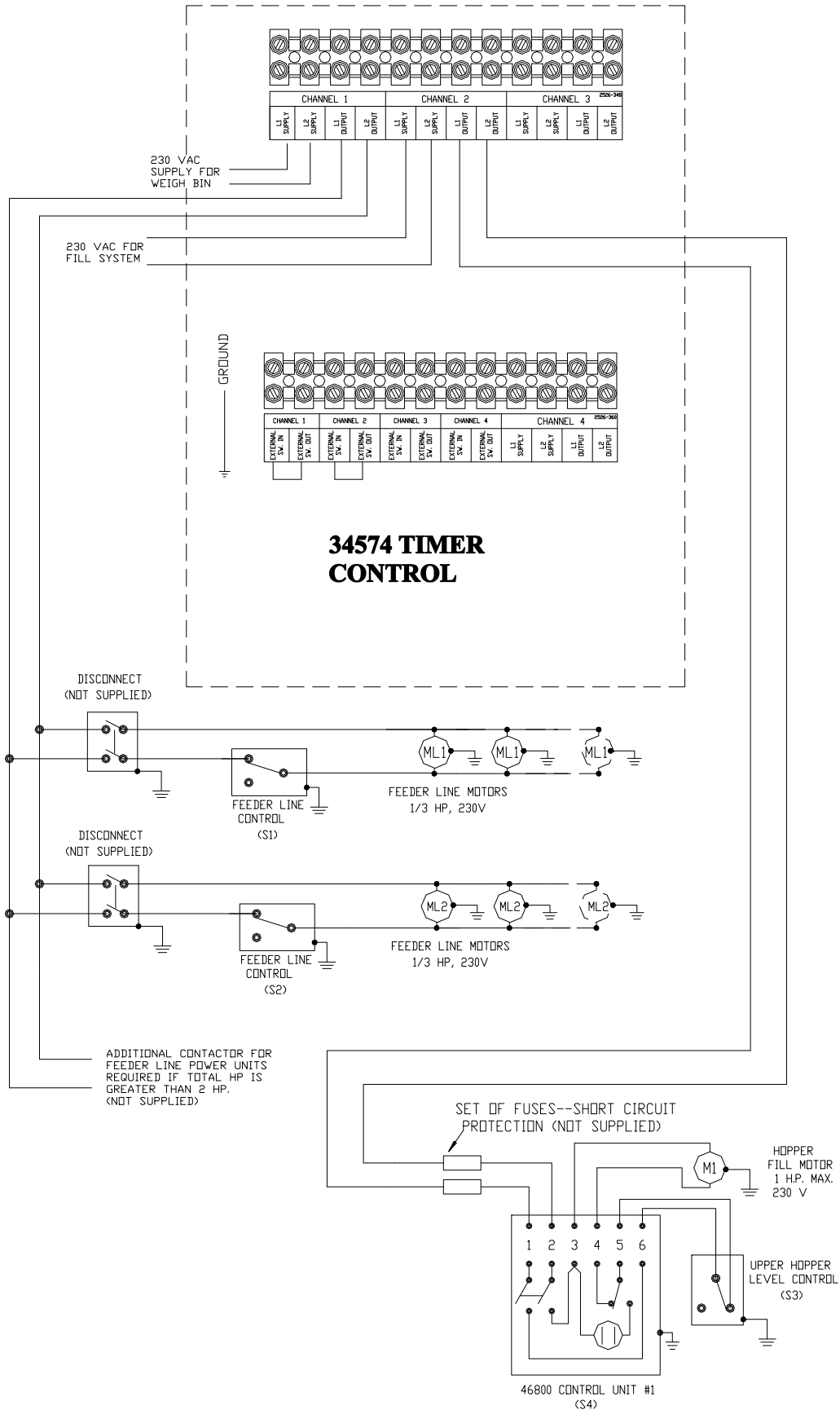

MF896.77 09/04

Sensor Plus™ Internal Wiring

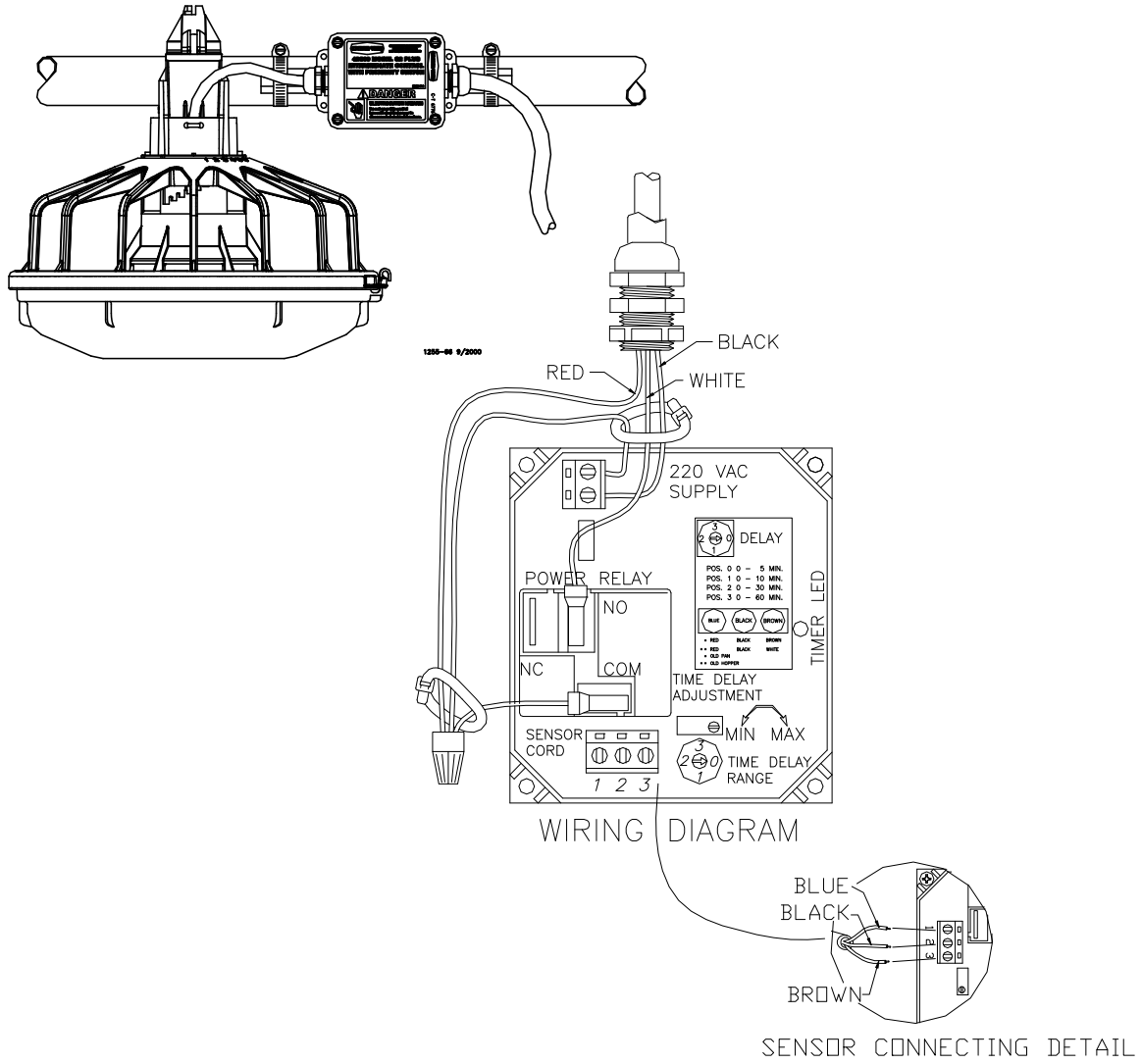

Feeder Management and Operation

This section Provides you with valuable information concerning feeder operation and management. It is important that you read this information and understand how the feeding system was designed to operate. Once you become familiar with the system, you may *custom operate* it to fit your individual needs.

Initial Start-up of the Feeding System

The Feeding system should be operated prior to birds being housed to make sure the installation is correct, the switches function properly, and to fill the feeder lines with feed.

It is common practice to use partial house brooding during the early days of broiler production. The CPF buildings have the feeder split in the center (center hopper set-up), normally only the feeders which are in the brood area are used during brood time.

The feeder tubes and Auger are supplied from the factory with a protective oil coating that will cause the system to deliver feed at a reduced rate. The oil coating will also create a larger load on the power unit (motor) until the system has been initially purged with feed, and becomes broken in.

To operate

1. Lower feeder lines so the feed pans are resting on the floor and the feed flood windows are completely open. Although the major weight of the feeder lines will be on the floor, do not remove all the weight from the suspension system and allow the cables to become slack.
2. Apply power to the feeder lines to check the operation. Allow to operate empty for 1-2 minutes.

NOTE: For feeder lines that have mid-line controls, the recommended bypass switch(s) are wired into the system for selection of partial or full house control. Select the switch so the mid line control is functional. As the feeder operates, the feed will stop at the mid line control pan.

3. With the shut-off slide on the feed bin boot closed, energize the Flex-Auger® fill system. After operation of approximately 1-2 minutes, open the boot slide 1/2 way to allow feed to be conveyed to the feeders.
4. Once feed begins to be dispensed into the feed hopper(s), manually shut-off the fill system.
5. Apply power again to the feeder lines. Operate the fill system manually to dispense approximately 50 lb. [23 kg] increments of feed into the feed hopper(s). Allow the feed hopper to become empty for 30 seconds between each increment to reduce load on the feeder motor. Continue this procedure until feed has been dispensed to all the feeder pans. When the feed reaches the control pan, the feeder line will be shut-off.
6. Once the feeder lines have been initially filled with feed, manually dispensing feed in 50 lb. [23 kg] increments will no longer be necessary. The shut-off slide on the Flex-Auger® fill system may be completely opened. Refer to the Flex-Auger fill system Operator's Manual for information when multiple feed bins are used.

General Operation of the CPF Feeding system

These recommendations are the guideline to aid producers with the use of the feeding system. With experience a feeding program will be developed to enhance the feeding systems performance. Several factors such as feed content, type of birds, climate, lighting programs, and etc. may dictate change from these recommendations.

The CPF has feed flood windows which allows the feeder pan, when lowered to the floor, to be filled with feed for the brooding of young birds. Start young birds with the feeder line lowered so the feed pans are resting on the floor and the feed flood windows are completely open. Although the major weight of the feeder lines will be on the floor, do not remove all the weight from the suspension system and allow the cables to become slack.

It is advisable to provide supplemental feed during the first few days for the young birds. This is especially true when partial house brooding is used. Supplemental feeders such as the CHORE-TIME® E-Z START™ Chick Feeder, provide extra feeding space and access to the feed.

With the feeders lowered to the floor and the feed flood windows open, the operation of the feeder will allow a high level of feed to be placed into the feed pans making it easy for the birds to find feed, adapt to the feeder, and begin to eat.

Do not operate the feeding system on automatic (full demand feed) when the feed windows are open. Chore-Time

recommends opening the feed windows for the first 8 to 14 days. The feeders will need to be operated at least 2 times a day for the first 5 days, and thereafter, 3 times a day or more as needed, while the windows are open. If it is not possible to operate the feeder manually 1-3 times a day during the brood time (windows open), then a time clock should be utilized to limit the number of times and length of time the feeder can operate. Failure to do one of the above will create the possibility of an excessive high feed level in the feed pans and the birds to waste feed.

DO NOT OPERATE THE FEEDING SYSTEM ON AUTOMATIC (FULL FEED) WHEN THE FEED WINDOWS ARE OPEN.

As the birds grow and become acclimated to the feeder pans, the feeder will need to be raised to the grow-out position. Before raising the feeder, it is recommended to allow the birds to eat the feed level down below the feed flood windows. This will ease the process of the feed flood windows closing properly.

Use the suspension system to raise the feeder(s) line. As the feeder is raised the feed flood windows will close. Continue raising the feeder lines until the feed pans just begin to clear the floor or litter.

IMPORTANT: When raising the feeder to the grow-out position, make sure the feed pans are to the point of just clearing the floor.

This will insure the feed will properly flow out into the feeder pan. When the feeder is raised to just clear the litter, there may a few places where the litter is lower and the pans seem too high. Do not be concerned as the birds will level the litter and at this young bird age, there will be sufficient feeder space.

The feeder should be set on the #4 position for most applications. The adjustment settings are easy to understand and change. Setting numbers are embossed on both sides of the grill so they may be easily seen from either side of the feeder line. See **Figure 49**.

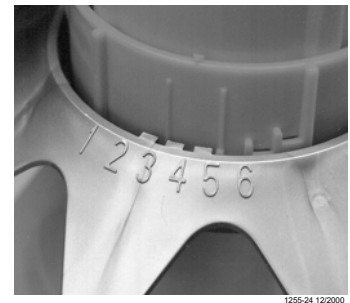

Figure 49. Feeder Pan Assembly adjustment

Feed texture and consistency, type of bird, or other variables may make it necessary to change to another feed setting position. The combination of proper pan height, feeder setting, and feeder operation will result in optimum feeder performance (refer to **Figure 50** for pan height information). The operator will learn what performs best for his/her situation with experience.

Mid-Line Control Pans

It is important the mid-line control be installed at least 2 feeder pans away from the Hopper on the return side so the birds will activate the feeder line. The feed setting for the mid-line control should be the same as the rest of the feeder pans on the feeder line (see **page 37** for adjustment information).

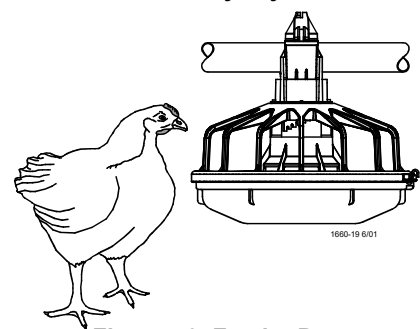

Figure 50. Feeder Pan Assembly height adjustment

Controlling the Feeders (optional equipment)

A time clock control is used with the feeding system to reduce excessive feeder operation time and limit feed wastage. The basic use of a time clock control is to allow periods of time during the day for the birds to reduce the feed level in the feeder pans and to limit the possibility of the birds creating a high feed level and wasting feed. This is not to be confused with lighting programs that have become very common place. If lighting or intermittent lighting programs are to be used, the use of the time clock control will be limited to just the light period. **Caution should be used to not restrict the feed from the birds during the light period.** Experience with the feeding system will determine how the time clock control is used.

The CPF Feeding System may be controlled by the #34385 Control Panel or the #34574 Time Clock Control. Refer to the instructions supplied with each control for information.

Electro-guard Operation

The electro-guard chargers should be operated on a separate electrical circuit so the anti-roost system can be shut off using a switch next to the entrance door when someone enters the building. Birds are less likely to become wild and flighty if the anti-roost is off when people are in the building.

Optional Slide Shut-Off

An Optional Slide Shut-Off is available for Windowed and Non-Windowed Feeder Assemblies. The Slide Shut-Off may be used on either style of feeders.

To assemble the Slide Shut-Off to the Non-Window Feed Cone, remove the thinned area from the Non-Windowed Feed Cone, then insert the Slide Shut-Off into the slots, as shown in **Figure 51**.

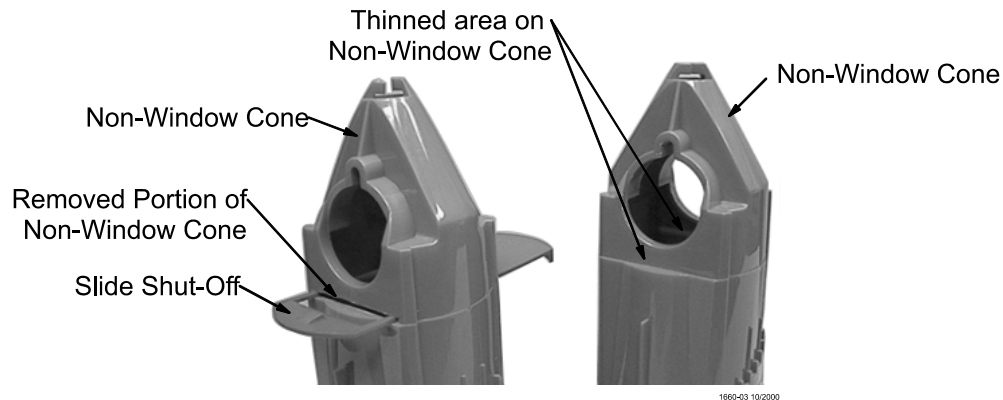

Figure 51. Optional Slide Shut-Off Assembly

Optional MODEL G Plus Pan Extension

An Optional Pan Extension is available for MODEL G Plus Pan Assemblies. The Pan Extension is used for Turkey Hens.

To assemble the Pan Extension on the MODEL G Plus Pan Assembly, place the Pan Extension around the MODEL G Plus Grill, as shown in **Figure 52**, and lock in place with the included carriage bolt and hex flange head nut

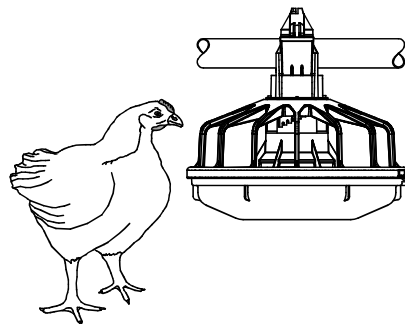

Figure 52. MODEL G Plus Pan Assembly with optional Pan Extension installed

Maintenance

Floor Feeding System Maintenance

The CPF Feeding system requires minimum maintenance. However, a routine periodic inspection of the equipment will prevent unnecessary problems.

Maintenance should be done by a qualified technician.

ALWAYS DISCONNECT POWER TO THE SYSTEM WHEN SERVICING OR MAINTAINING THE EQUIPMENT. FAILURE TO DISCONNECT POWER MAY CAUSE INJURY OR DEATH.

Gear Head Maintenance

Refer to **Figure 53**.

Check the oil level in the gear heads at installation and every 6 months. The Pipe Plug, on the side of the gear head, indicates proper oil level. Add SAE 40W oil when necessary.

The oil in the gearheads should be replaced every 12 months with new SAE 40W oil

- A. Remove the bottom Pipe Plug to drain the oil. Discard used oil in accordance with local and national codes.
- B. Wipe any debris off the magnet on the bottom Pipe Plug and reinstall. Remove the side Pipe Plug and (top) Vent Plug.
- C. Set the power unit in the horizontal position.
- D. 2-Stage Gearheads: Add approximately 9 oz. (266 ml) of SAE 40W oil through top hole. This should be just enough oil to reach the side Pipe Plug.
3-Stage Gearheads (3261-9, 3261-12, 3261-14): Add approximately 13 oz. (384 ml) of SAE 40W oil through top hole. This should be just enough oil to reach the side Pipe Plug.
- E. Install the side Pipe Plug and (top) Vent Plug.

Vent/Oil Fill Plug



1660-22 1/2001

Check the oil level in Gearhead at installation.

Check the oil level every 6 months.

Check the oil level at the side plug if oil is needed use SAE 40W.

Oil capacity for the 2 stage gearhead is 9 oz [266 ml]

Oil capacity for the 3 stage gearhead is 13 oz [384 ml].
The oil should be changed every 12 months.

Figure 53. Gearhead Maintenance

Check equipment for loose hardware after the first flock and then every 6 months. Tighten if necessary.

Mechanical Switch Adjustment procedure for Control Pans

- Turn the adjustment nut counter-clockwise until the switch clicks.
- Turn the adjustment nut clockwise until the switch clicks.
- Turn the adjustment nut counter-clockwise 3/4 turn.

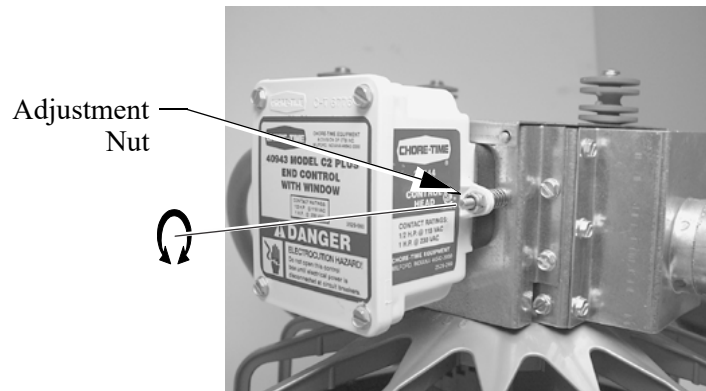

1660-23 1/2001

SENSOR PLUS™ Sensor Switch Adjustment for Control Pans

Refer to **Figure 55**.

The SENSOR PLUS™ Pan Half Round Sensor Switch is adjusted at the factory to a sensitivity of .25" away from face of sensor and a time delay of 15 seconds with the range selector in the "0" position. The time delay adjustment is 0 seconds to 5 minutes.

To adjust the time delay:

- For less time-turn Time Delay Adjustment Screw counter-clockwise (Light blinks fast)
- For more time-turn Time Delay Adjustment Screw clockwise (Light blinks slow)

Feeder Line

Keep anti-roost cables tightly stretched. This increases the effectiveness of the electro-guard anti-roost system and keep the pans from being tilted when birds push against them.

Remove all feed from the feeder when there are no birds in the house and when the building is washed and disinfected.

Turn the feeders off prior to removing the birds from the house. This will allow them to clean the feed out of the pans.

If the system is not to be used for an extended period of time, remove all the feed from the feeder lines and feeder pans.

Disconnect power to the system to prevent accidentally starting the system.

If the system must be disassembled, extreme caution must be used to prevent injury from springing auger. Refer to **Figure 56**.

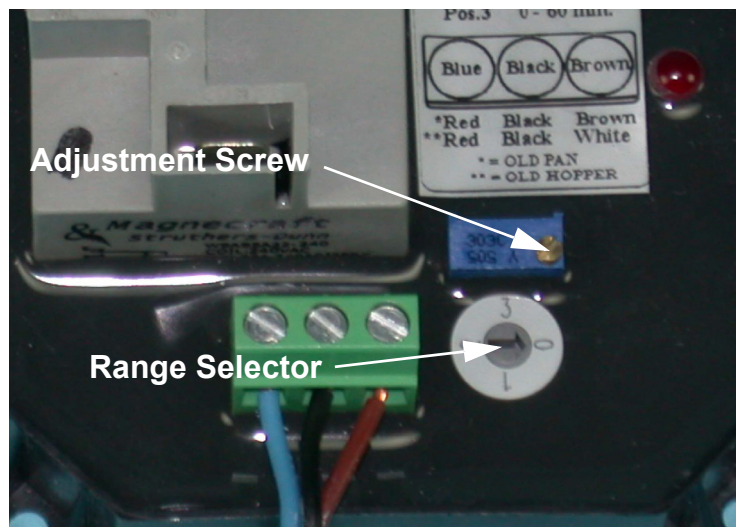
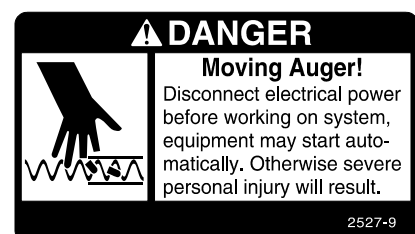

Figure 55. Adjusting the Sensor Plus Proximity Switch



2527-9

Power Lift Winch Maintenance

Refer to **Figure 56**.

Grease the winch every 6 months with 1 to 2 shots of common industrial or automotive grease.
DO NOT OVER GREASE THE WINCH.

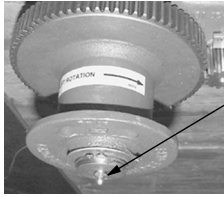

1) Grease the Power Lift Winch every 6 months with 1 to 2 shots of common industrial or automotive grease
DO NOT OVER GREASE THE POWER LIFT WINCH

1690-24 6/2001

Figure 56. Maintenance to the Power Lift Winch

Agri-Timer

Replacing the batteries in the Agri-Timer

- A. Disconnect electrical service at the breaker.
- B. Remove the (6) screws and the face of the control.
- C. Cut the wire ties to allow for battery removal.
- D. Replace the existing batteries with new "AAA" batteries.
- E. Replace wire ties to secure the new batteries in place.
- F. Reinstall the face of the timer and secure using (2) screws previously removed.
- G. Reconnect electrical service to the Agri-Time Control.

Remove any feed build-up in the Safety Switch Boxes in the Control Units.

It may be necessary to periodically retighten the shocker cable. Be sure to disconnect power to the shocker before servicing the equipment.

This page left blank for notes.

Parts Listing

150# Hopper Components

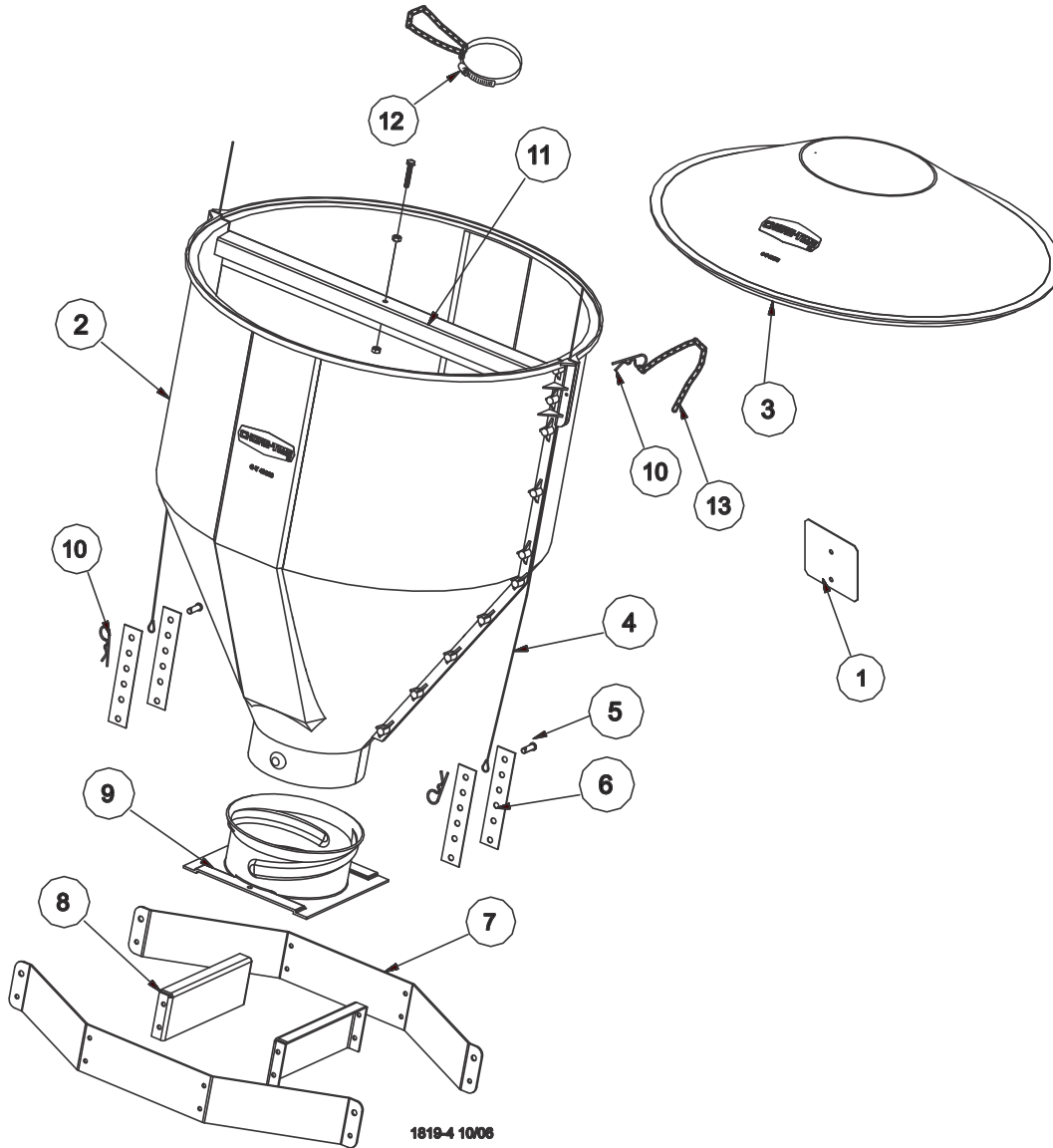

Key	Description	Without	With
		Cover	Cover
		48926	49267
1	Hopper Half	49028	49028
2	Hopper Half (Machined)	--	--
3	Cover	--	48675
4	Cable Assembly	2809-3	2809-3
5	Clevis Pin	2797-1	2797-1
6	Adjustment Bracket	2706	2706
7	Suspension Angle	48679	48679
8	Suspension Brace	48680	48680
9	Twist Lock Collar	49041	49041
10	Hairpin	2664	2664
11	Brace	49029	49029
12	Tube Support Assembly	14367	14367

Hopper Mount Bracket (Optional)

Part Number 49358 - Hopper Suspension Kit

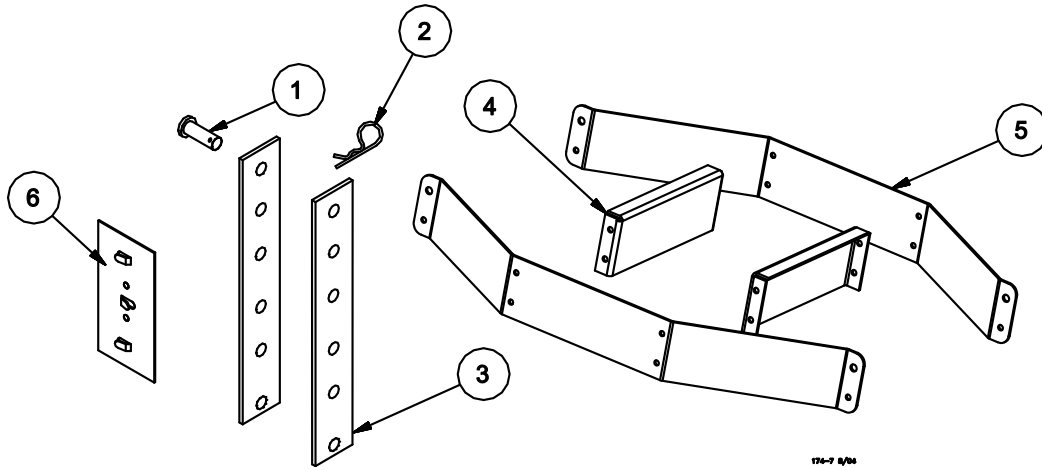

Item	Description	Part No. Single Boot Kit	Part No. Twin Boot Kit
1	Clevis Pin, 5/16" x 1"	2797-1	2797-1
2	Adjustment Bracket	2706	2706
3	Hair Pin	2664	2664
4	Suspension Brace	48680	48680
5	Suspension Angle	48679	48679
6	Cable Guide	34573	34573
7	Cable Assembly	2809-3	2809-3

Boot Assembly Part No. 34824

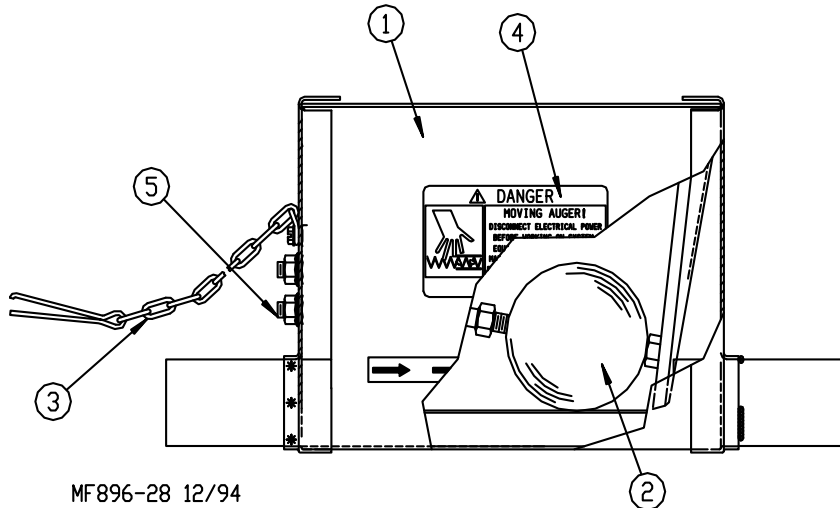

MF896-28 12/94

Item	Description	Part No.
1	Boot Weldment	34811
2	Agitator Assembly	34804
	Agitator Ball	34803
3	Latch pin Assembly	2683
4	Danger Decal	2527-9
5	5/16" U-Bolt	34823

Miscellaneous Components

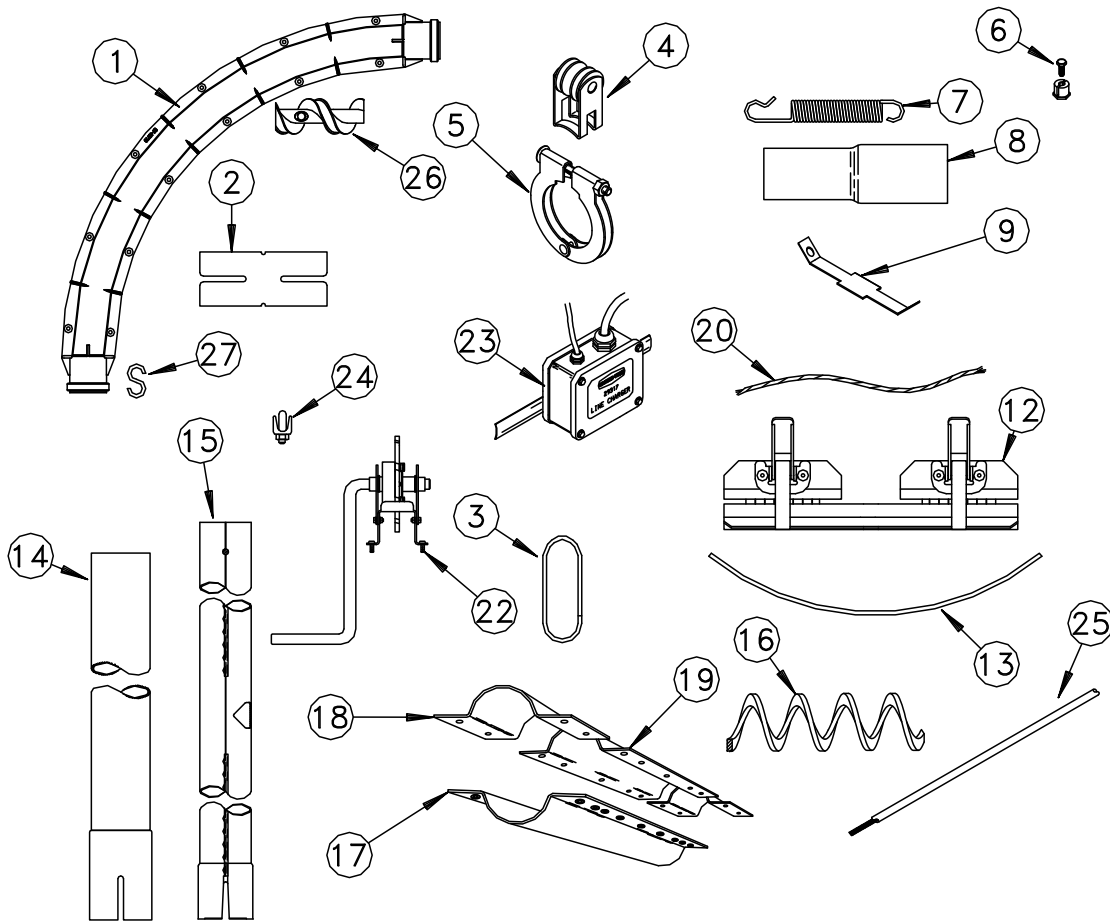

MF896-20 7/96

Item	Description	Part No.	Item	Description	Part No.
1	90 Degree Molded Elbow Half	46779	15	Roll-Formed Feeder Tube	
2	Tube Coupling (1-3/4" Diameter)	2123		--9 3/4"-Hole	6854-1
	Tube Coupling (2" Diameter)	29691		--10 3/4"-Hole	6854-4
3	Hanger	4207		--12 3/4"-Hole	6854-7
4	Insulator Bracket	24060		--12"/No Hole	6854-14
5	Tube Clamp	24063	16**	Auger	28103-0
	2" Tube Clamp	29520	17*	Service Section Base	28153
6	3/32" Cable Clamp	1826	18*	Service Section Clamp	28151
7	Spring	7551	19*	Service Section Cover	28152
8	Tube Adapter	28107	20	1/16" Cable	1922
9	Elbow Strap	48357	21		
10			22	Auger Driver	28126
11			23	Line Charger	29317
12	Welding Fixture	25494	24	1/8" Cable Clamp	14898
13	Anti-Roost Wire	28109	25	Hi-Voltage Cable (330')	28994-330
14	4' Extension Tube	28128		Hi-Voltage Cable (500')	28994-500
				Hi-Voltage Cable (165')	28994-165
			26	Auger Connector	29055-2
			27	"S" Hook	723
			28	Anti-Swing Lock-Pulleys	34570

+These Components may be ordered as an assembly under Chore-Time P/N 7604.

*These Components may be ordered as an assembly under Chore-Time P/N 28127.





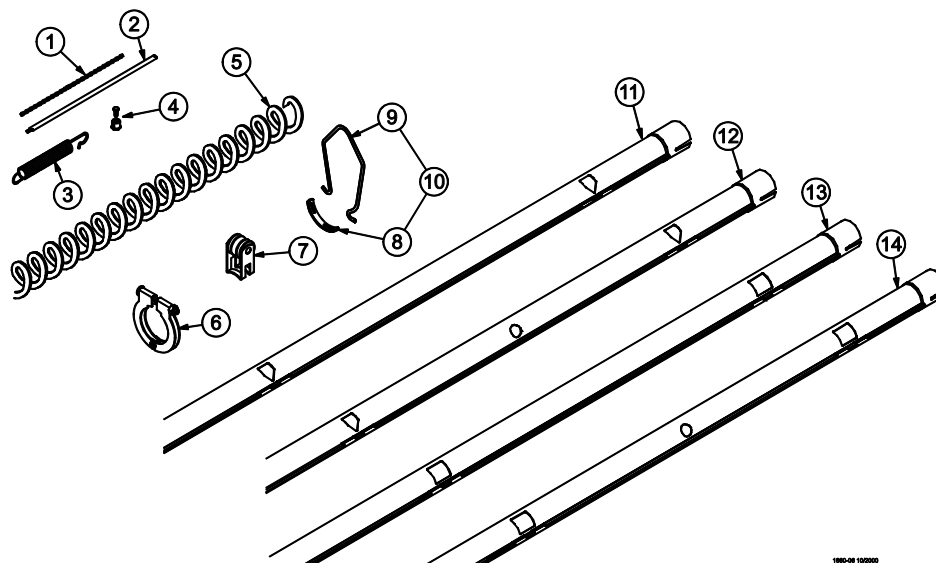



**The Auger may be ordered in lengths from 100' to 330'. Include the specific length as a suffix to the Part Number (example: 28103-220 is a 220' roll of Auger).

Feeder Line Components

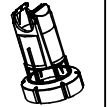
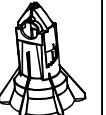

Item	Description	Part No.
1	1/16" Cable	1922
2	Charger Wire (165') Charger Wire (330')	28994-165 28994-330
3	Spring	7551
4	1/16" Cable Clamp	1826
5*	Auger	6820-0
6	Tube Clamp	24063
7	Anti-Roost Bracket	24060
8	Hanger Bracket	7297
9	Hanger Strap	7298
10	Hanger Kit	7299
11	Standard Feeder Tube-1 3/4" Roll Form - 9', 4 Hole Tube - 10', 3 Hole Tube - 10', 4 Hole Tube - 12', 3 Hole Tube - 12', 4 Hole Tube - 12', 5 Hole Tube	6854-1 6854-5 6854-4 6854-8 6854-7 6854-6
12	Standard Feeder Tube-1 3/4" with Chick Holes (EZ. Holes) - 9', 4 Hole, 4 EZ. Holes - 10', 4 Hole, 4 EZ. Holes - 12', 4 Hole, 4 EZ. Holes - 12', 5 Hole, 5 EZ. Holes - 10', 3 Hole, 3 EZ. Holes - 9', 4 Hole, 2 EZ. Holes - 10', 4 Hole, 2 EZ. Holes - 12', 4 Hole, 2 EZ. Holes	6854-15 6854-16 6854-17 6854-18 6854-19 6854-20 6854-21 6854-22
13	Control Feeder Tube-1 3/4" Roll Form - 9', 4 Hole Tube - 10', 4 Hole Tube - 10', 3 Hole Tube - 12', 3 Hole Tube - 12', 4 Hole Tube - 12', 5 Hole Tube	43006-1 43006-4 43006-5 43006-8 43006-7 43006-6
14	Control Feeder Tube-1 3/4" with Chick Holes (EZ. Holes) - 9', 4 Hole, 4 EZ. Holes - 10', 4 Hole, 4 EZ. Holes - 12', 4 Hole, 4 EZ. Holes - 12', 5 Hole, 5 EZ. Holes	43006-15 43006-16 43006-17 43006-18
*Round up to the nearest 10'. Auger lengths from 50' to 500'. Example: 6820-200 would be a 200' roll of 6820 Auger.		

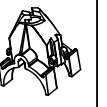
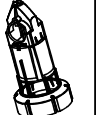
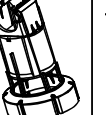
Model C2 Plus Feeder Pan Assemblies

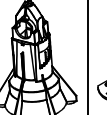

	Standard Cones							Shut-Off Cones					
	 38600	 39567	 38604	 38601	 38602	 39566	 39565	 38603	 42701	 42703	 42705	 42706	
40687 Model C2 Plus Feeder Assembly	X	X	X	X									
40689 Model C2 Plus Feeder Assembly with Removeable Top	X	X	X		X			X					
40688 Model C2 Plus Feeder Assembly Non-Window	X	X				X							
40690 Model C2 Plus Feeder Assembly Non-Window and Removable Top	X	X					X	X					
42697 Model C2 Plus Feeder Assembly with Shut-Off	X	X	X						X				X
42700 Model C2 Plus Feeder Assembly with Removable Top and Shut-Off	X	X	X					X		X			X
42695 Model C2 Plus Feeder Assembly Non-Window and Shut-Off	X	X										X	X
42698 Model C2 Plus Feeder Assembly Non-Window and Removable Top and Shut-Off	X	X						X			X		X

1660-07 10/2000





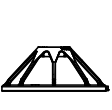
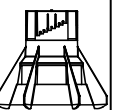
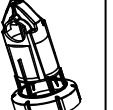
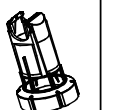
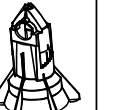

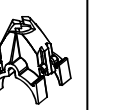
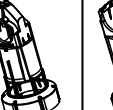
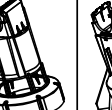
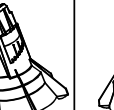
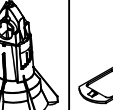

Model C2 Plus Shallow Feeder Pan Assemblies

	Standard Cones												39564
	41500	39567	41504	41502	41503	41505	41892	38603	42237	42238	42678	42677	
42006 Model C2 Plus Shallow Feeder	X	X	X	X									
42007 Model C2 Plus Shallow Feeder with Removeable Top	X	X	X		X			X					
42008 Model C2 Plus Shallow Feeder Non-Window	X	X				X							
42009 Model C2 Plus Shallow Feeder Non-Window and Removable Top	X	X					X	X					
43470 Model C2 Plus Shallow Feeder with Shut-Off	X	X	X						X				X
43472 Model C2 Plus Shallow Feeder with Removable Top and Shut-Off	X	X	X					X		X			X
42696 Model C2 Plus Shallow Feeder Non-Window and Shut-Off	X	X										X	X
42699 Model C2 Plus Shallow Feeder Non-Window and Removable Top and Shut-Off	X	X						X			X		X

Model G Plus Feeder Pan Assemblies

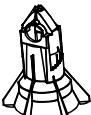
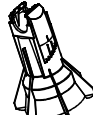
	Standard Cones												Shut-Off Cones
													
	41501	38599	38604	38601	38602	39566	39565	38603	42701	42703	42705	42706	39564
40683 Model G Plus Feeder Assembly	X	X	X	X									
40685 Model G Plus Feeder Assembly with Removeable Top	X	X	X		X			X					
40684 Model G Plus Feeder Assembly Non-Window	X	X				X							
40686 Model G Plus Feeder Assembly Non-Window and Removable Top	X	X					X	X					
42694 Model G Plus Feeder Assembly with Shut-Off	X	X	X						X				X
42691 Model G Plus Feeder Assembly with Removable Top and Shut-Off	X	X	X					X		X			X
42692 Model G Plus Feeder Assembly Non-Window and Shut-Off	X	X										X	X
42689 Model G Plus Feeder Assembly Non-Window and Removable Top and Shut-Off	X	X						X			X		X

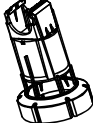
Model G Plus Shallow Feeder Pan Assemblies

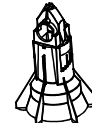
	Standard Cones							Shut-Off Cones					
													
	41501	38599	38604	38601	38602	39566	39565	38603	42701	42703	42705	42706	39564
40683 Model G Plus Feeder Assembly	X	X	X	X									
40685 Model G Plus Feeder Assembly with Removeable Top	X	X	X		X			X					
40684 Model G Plus Feeder Assembly Non-Window	X	X				X							
40686 Model G Plus Feeder Assembly Non-Window and Removable Top	X	X					X	X					
42694 Model G Plus Feeder Assembly with Shut-Off	X	X	X						X				X
42691 Model G Plus Feeder Assembly with Removeable Top and Shut-Off	X	X	X					X		X			X
42692 Model G Plus Feeder Assembly Non-Window and Shut-Off	X	X										X	X
42689 Model G Plus Feeder Assembly Non-Window and Removable Top and Shut-Off	X	X						X			X		X

1680-09 10/2000

Mechanical Mid-Line Control

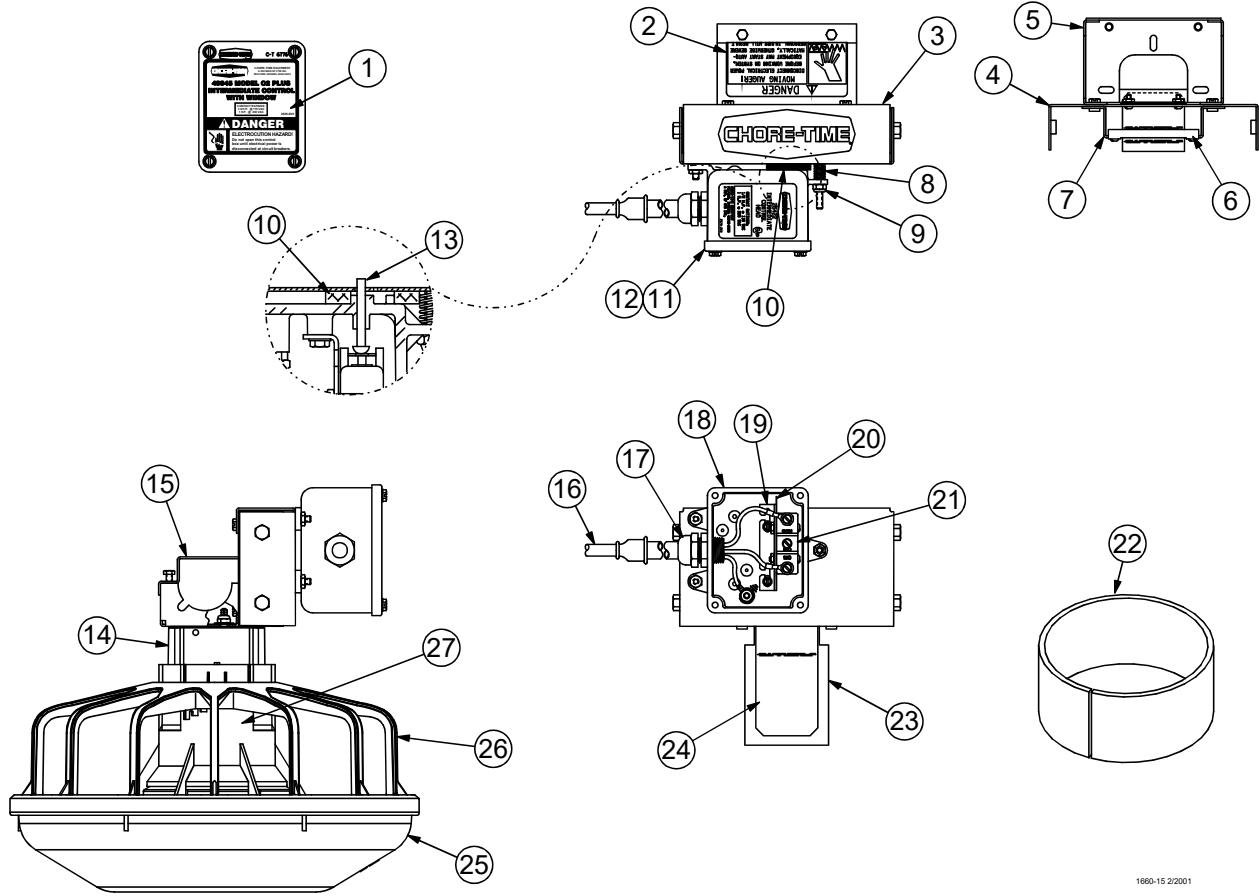

1660-15 2/2001

Item	Description	MODEL C2 Plus Standard Part No. 40945	MODEL C2 Plus Shallow Part No. 42013	MODEL G Plus Standard Part No. 40946	MODEL G Plus Shallow Part No. 42029
1	Danger/Product Identification Decal	2529-658	2529-248	2529-657	2529-694
2	Danger Decal	2527-9	2527-9	2527-9	2527-9
3	Back Cover	25047	25047	25047	25047
4	Front Panel	25046	25046	25046	25046
5	Tube Support	41364	41364	41364	41364
6	Paddle Retainer	25045	25045	25045	25045
7	Pivot Bracket	25048	25048	25048	25048
8	Spring	6972	6972	6972	6972
9	#10-32 Lock Nut	6963	6963	6963	6963
10	Gasket	6968-1	6968-1	6968-1	6968-1
11	Switch Box Cover	6776	6776	6776	6776
12	Gasket	6777	6777	6777	6777
13	Actuator Pin	8757	8757	8757	8757
14	Support Cone Assembly	40947	37371	40947	37371
15	Tube Retainer	14756	14756	14756	14756
16	Cord Assembly	4999-49	4999-49	4999-49	4999-49
17	1/2" Liquid Tight Connector	24685	24685	24685	24685
18	Machined Switch Box	34842	34842	34842	34842
19	Switch Bracket	46122	46122	46122	46122
20	Switch Insulation	1907-5	1907-5	1907-5	1907-5
21*	Actuator Switch	46091	46091	46091	46091
22	Cut Sleeve	43110	43110	43110	43110
23	Mylar Assembly	25318	25318	25318	25318
24	Switch Paddle	46123	46123	46123	46123
25	Feeder Pan	41501	41500	41501	41500
26	Feeder Grill	39567	39567	38599	38599
27	Adjustment Cone	38604	41504	38604	41504

*Actuator Switch, Chore-Time part number 7114, is no longer available. When replacing, use 7114 Switch Replacement Kit Part Number 46678.

SENSOR PLUS MidLine Control

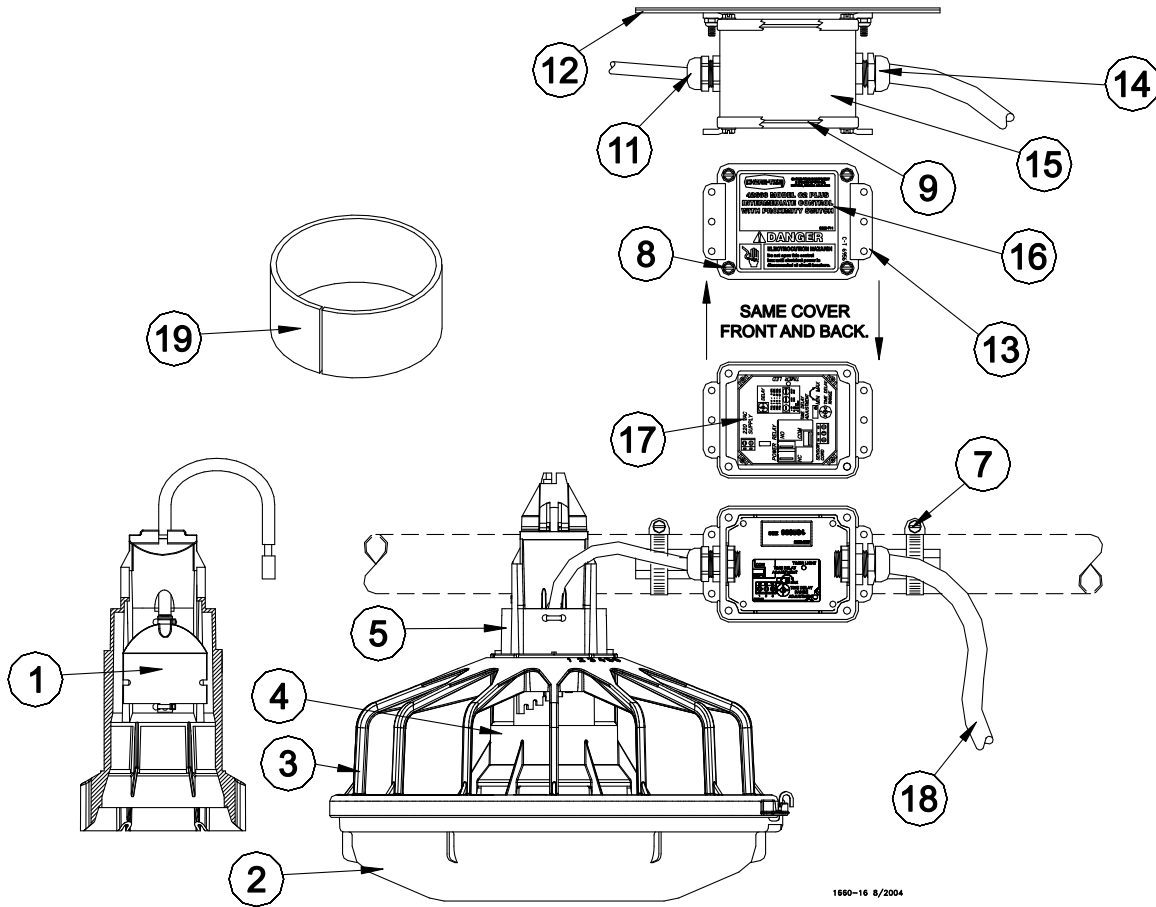

1660-16 8/2004

Item	Description	MODEL C2 Plus Standard Part No. 42663	MODEL C2 Plus Shallow Part No. 44881	MODEL G Plus Standard Part No. 42664	MODEL G Plus Shallow Part No. 44883
1	Pan Half Round Sensor	48200	48200	48200	48200
2	Feeder Pan	41501	41500	41501	41500
3	Feeder Grill	39567	39567	38599	38599
4	Adjustment Cone	38604	41504	38604	41504
5	Support Cone	377077	44884	37077	44884
6	Slide Top Cap	38603	38603	38603	38603
7	Hose Clamp	3527	3527	3527	3527
8	#10 x 1/2 Hex Washer Head Screw	28075	28075	28075	28075
9	Switch Box Gasket	6777	6777	6777	6777
10	----	----	----	----	----
11	Liquid Tight Connector	23779	23779	23779	23779
12	Tube Mount	42681	42681	42681	42681
13	Terminal Box Mounting Cover	6956	6956	6956	6956
14	Liquid Tight Connector	24685	24685	24685	24685
15	General Purpose Terminal Box	42627-2	42627-2	42627-2	42627-2
16	Danger/Product Identification Decal	2529-711	2529-728	2529-712	2529-730
17	Pan Half Round Sensor	48200	48200	48200	48200
18	Cord Assembly	4999-103	4999-103	4999-103	4999-103
19	Cut Sleeve	43110	43110	43110	43110

Power Unit and Driver Assemblies

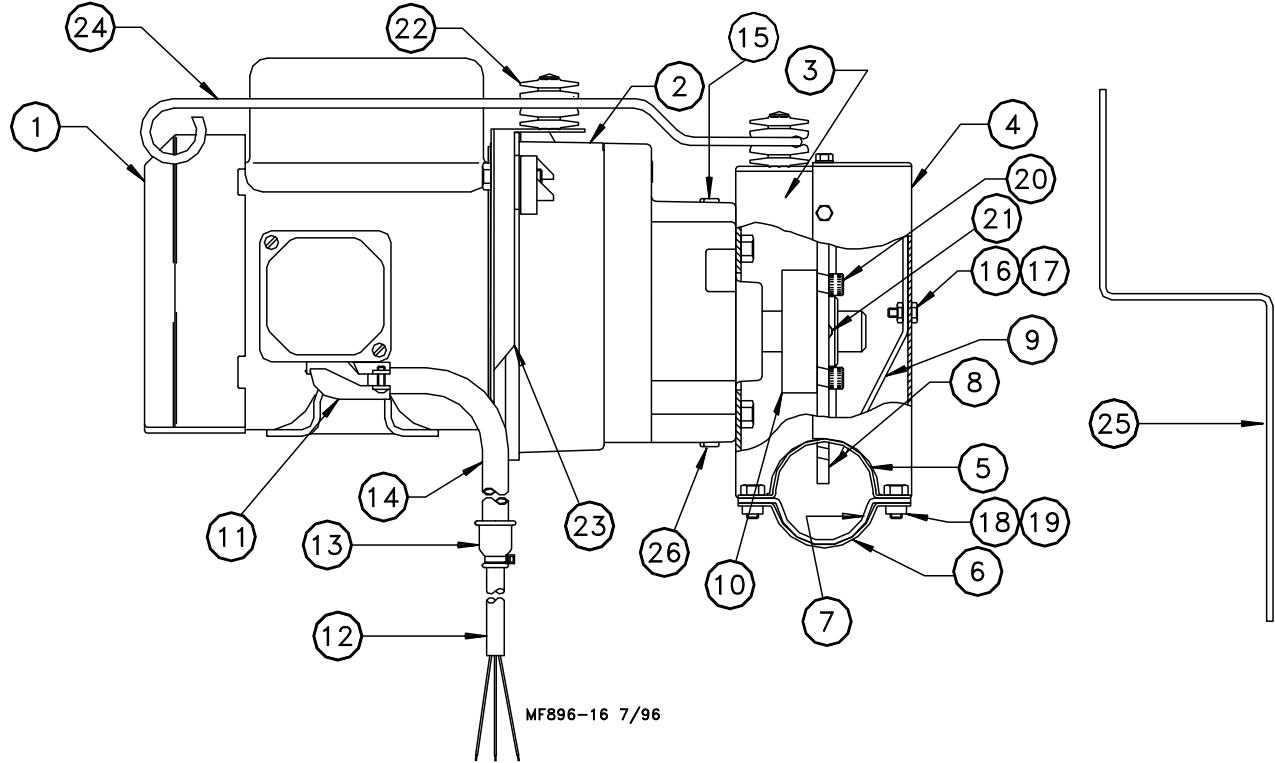

MF896-16 7/96

Item	Description	230V	220V	220/380 V
		60 Hz 1 Ø 62 R.P.M. P/N 49271	50 Hz 1 Ø 62 R.P.M P/N 49272	50 Hz 3 Ø 62 R.P.M P/N 49273
1	Motor	14733	14750	28031EUR
2	Gearhead Assembly	49274	49275	40257
3	Drive Unit Base	28149	28149	28149
4	Drive Unit Cover	8208	8208	8208
5	End Connector	9634	9634	9634
6	Base Connector Weldment	9636	9636	9636
7	Wear Shoe	8210	8210	8210
8	Drive Sprocket	8463	8463	8463
9	Auger Brace	24674	24674	24674
10	Drive Gear Hub	8213	8213	8213
11	90 degree Connector	4228	4228	----
12	Cord Assembly	27719	27719	----
13	Reducing Seal	7815	7815	----
14	Vinyl Tubing	7814	7814	----
15	Pipe Plug	3516	3516	3516
16	10-24 x 1/2" Hex Head Screw	4416-3	4416-3	4416-3
17	10-24 Lock Nut	34019	34019	34019
18	1/4-20 x 1/2" Hex Head Screw	1487	1487	1487
19	1/4-20 Lock Nut	1269	1269	1269
20	5/16-18 SHCS	6850-1	6850-1	6850-1
21	Dowel Pin	8699	8699	8699
22	Insulator	2976	2976	2976
23	Anti-Roost Bracket	28104	28104	28104
24	Anti-Roost Wire	28150	28150	28150
25	Drive Unit Wire	29695	29695	29695
26	Magnetic Pipe Plug	30160	30160	30160
--	1/8" Cable Clamp	14898	14898	14898

Model G Plus Pan Extension (Optional)

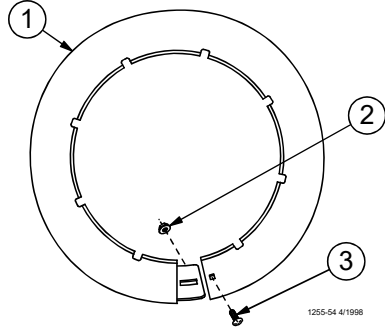

Item	Description	Part No.
1	Pan Extension	29510
2	Lock Nut	24208
3	1/4" Carriage Bolt	22692

47687 Power Winch

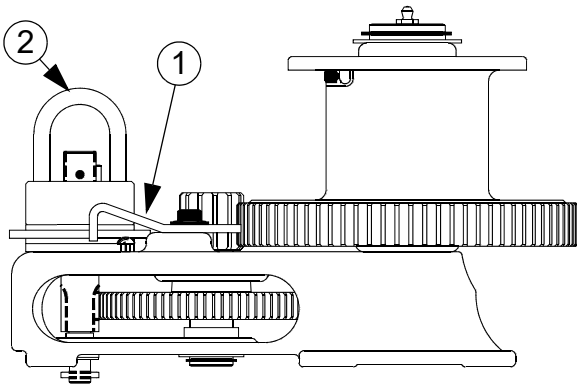

Item	Qty.	Description	Part No.
1	1	Pawl	47687-5
2	1	Input Shaft Assembly	47687-1

Miscellaneous Suspension Components

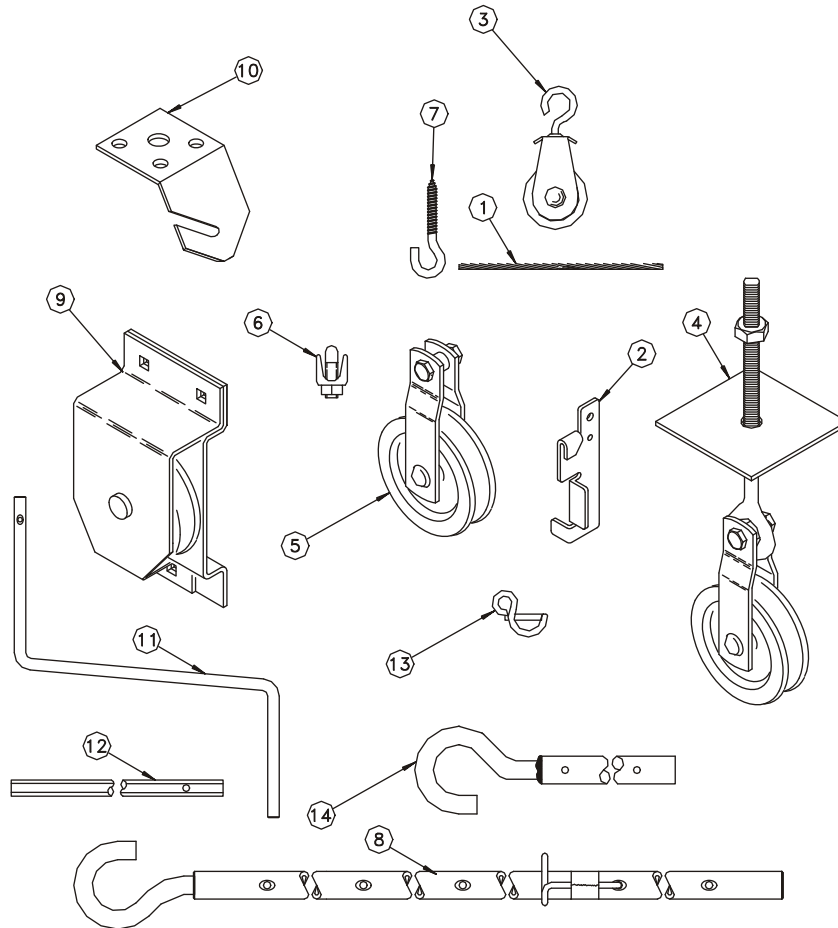

Item	Description	Part No.
1	3/16" Cable	1213
	1/8" Cable	27975
2	Cable Lock	14337
3	Pulley with Swivel	3004
4	Heavy Duty Pulley Assembly	2014
5	Pulley	2500
6	3/16" Cable Clamp	732
7	Screw Hook	2014
8	Extendable Drive Tube	47637
9	Pulley Assembly	28429
10	Ceiling Hook	28550
11	Handle Shank	3148
12	Drill Adapter Shaft	2886
13	Winch Handle Pin	3761
14	Winch Drive Tube (4')	2884-1
	Winch Drive Tube (8')	2884-2
	Winch Drive Tube (2')	2884-4
--	Full Line Suspension Kit	7948

Item 11 and Item 13 may be ordered as a kit under Part No. 2885.

Item 12 and Item 13 may be ordered as a kit under Part No. 2886

Item 11, 13 and 8 may be ordered as a kit under Part No. 47638.

Item 10 and Item 12 may be ordered as a kit under part no. 2885. Item 11 and Item 12 may be ordered as a kit under part no. 2886.

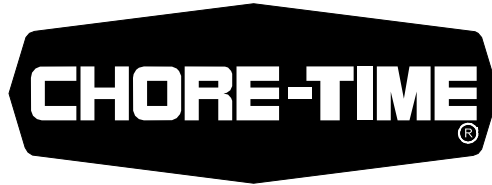

**MADE TO WORK.
BUILT TO LAST.®**

Revisions to this Manual

Page No.	Description of Change	ECO
52	Was 2883 Winch	35577
Various	Updated Graphics (Darker)	

**For additional parts and information, contact your nearest Chore-Time distributor or representative.
Find your nearest distributor at: www.choretime.com/contacts**

CTB, Inc.
PO Box 2000
Milford, Indiana 46542-2000 USA
Phone (574) 658-4101
Email: choretime@choretime.com
Internet: www.choretime.com