



Poultry Production Systems

MODEL ATF™ PLUS

Feeding System

Installation and Operators Manual

Installation and Operators Manual

Installation and Operators Manual

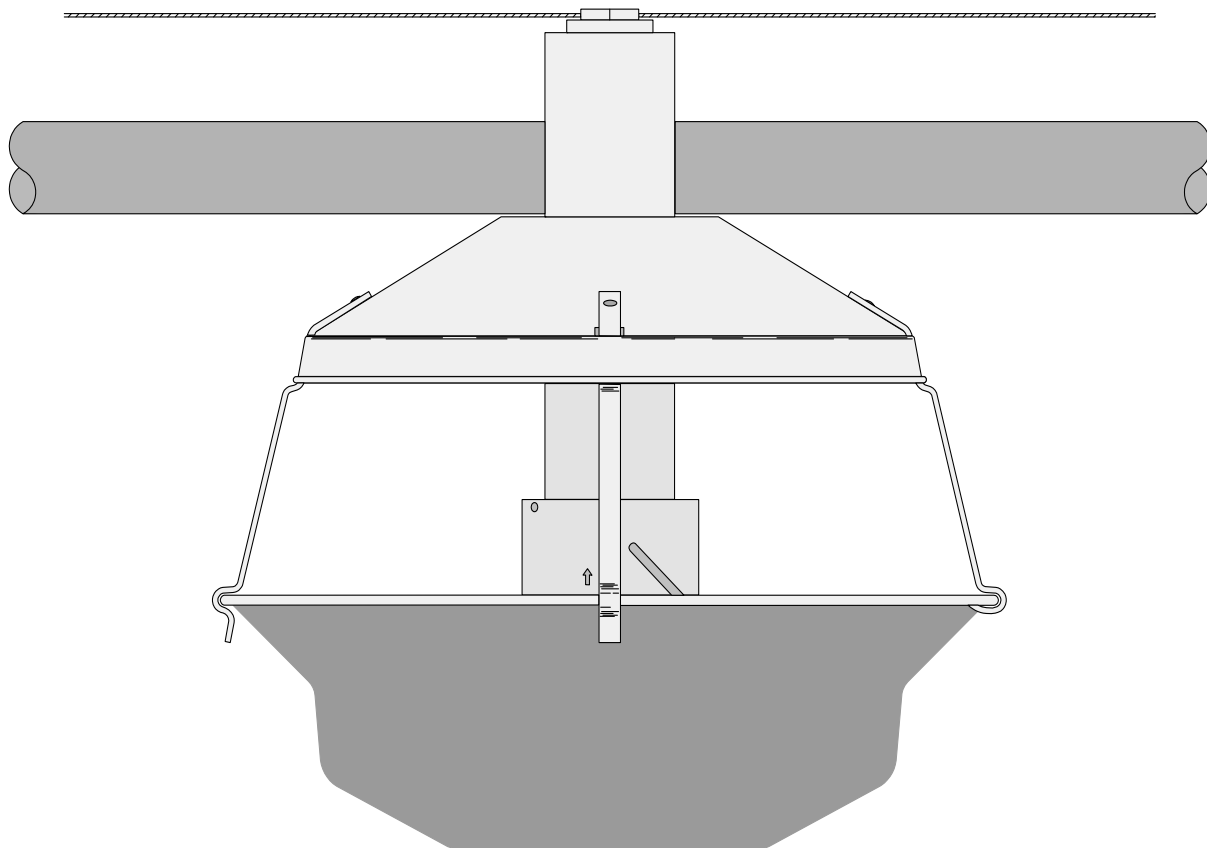

Chore-Time Warranty

LIMITED WARRANTY

CTB, Inc. (“Chore-Time”) warrants each new CHORE-TIME Product manufactured by Chore-Time to be free from defects in material or workmanship under normal usage and conditions, for One (1) year from the date of installation by the original purchaser (“Warranty”). Chore-Time provides for an extension of the aforementioned Warranty period (“Extended Warranty Period”) with respect to certain Product parts. If such a defect is determined by Chore-Time to exist within the applicable period, Chore-Time will, at its option, (a) repair the Product or Component Part free of charge, F.O.B. the factory of manufacture or (b) replace the Product or Component Part free of charge, F.O.B. the factory of manufacture. This Warranty is not transferable, and applies only to the original purchaser of the Product.

CONDITIONS AND LIMITATIONS

THIS WARRANTY CONSTITUTES CHORE-TIME’S ENTIRE AND SOLE WARRANTY AND CHORE-TIME EXPRESSLY DISCLAIMS ANY AND ALL OTHER WARRANTIES, INCLUDING, BUT NOT LIMITED TO, EXPRESS AND IMPLIED WARRANTIES, INCLUDING, WITHOUT LIMITATION, WARRANTIES AS TO MERCHANTABILITY OR FITNESS FOR PARTICULAR PURPOSES. CHORE-TIME shall not be liable for any direct, indirect, incidental, consequential or special damages which any purchaser may suffer or claim to suffer as a result of any defect in the Product. Consequential or Special Damages as used herein include, but are not limited to, lost or damaged products or goods, costs of transportation, lost sales, lost orders, lost income, increased overhead, labor and incidental costs, and operational inefficiencies. *Some jurisdictions prohibit limitations on implied warranties and/or the exclusion or limitation of such damages, so these limitations and exclusions may not apply to you. This warranty gives the original purchaser specific legal rights. You may also have other rights based upon your specific jurisdiction.*

Compliance with federal, state and local rules which apply to the location, installation and use of the Product are the responsibility of the original purchaser, and CHORE-TIME shall not be liable for any damages which may result from non-compliance with such rules.

The following circumstances shall render this Warranty void:

- Modifications made to the Product not specifically delineated in the Product manual.
- Product not installed and/or operated in accordance with the instructions published by the CHORE-TIME.
- All components of the Product are not original equipment supplied by CHORE-TIME.
- Product was not purchased from and/or installed by a CHORE-TIME authorized distributor or certified representative.
- Product experienced malfunction or failure resulting from misuse, abuse, mismanagement, negligence, alteration, accident, or lack of proper maintenance, or from lightning strikes, electrical power surges or interruption of electricity.
- Product experienced corrosion, material deterioration and/or equipment malfunction caused by or consistent with the application of chemicals, minerals, sediments or other foreign elements.
- Product was used for any purpose other than for the care of poultry and livestock.
-

The Warranty and Extended Warranty may only be modified in writing by an officer of CHORE-TIME. CHORE-TIME shall have no obligation or responsibility for any representations or warranties made by or on behalf of any distributor, dealer, agent or certified representative.

Effective: **June 2023**

Thank You

The employees of CTB, Inc. would like to thank you for your recent Chore-Time purchase. If a problem should arise, your Chore-Time distributor can supply the necessary information to help you.

Contents

Topic	Page
Chore-Time Warranty	2
About This Manual	5
Safety Information	5
Safety Instructions	6
Follow Safety Instructions	6
Decal Descriptions	6
DANGER: Moving Auger	6
DANGER: Electrical Hazard	6
CAUTION:	6
General	7
Support Information	7
MODEL ATF™ PLUS Recommendations & Guidelines	7
Glossary of Terms	8
Planning the Floor Feeding System	9
Suspension System	10
Suspension System Offset	13
Screw Hook Installation	13
Ceiling Hook Installation	14
Swivel Pulley Installation	14
.....	14
Power Winch Installation	15
Drop Installation	15
Hopper Assembly Procedure	16
Feeder Assembly	17
MODEL ATF™ PLUS Feeding System	17
Feeder Tube Assembly	19
Feeder Line Assembly & Suspension	19
Feeder Line Installation	19
Control Unit Installation	21
Auger Installation	23
Auger stretch:	25
Auger Brazing	26
Winch Adjustable Feed Level Tubes (optional equipment)	27
Operation	27
Installation of the Winch Adjustable Feed Level Tube System	27
Anti-Roost Installation	30
Wiring Diagrams	33
Sensor Plus	33
End & Intermediate Control Wiring Diagrams: Single Phase	33
Single Phase Wiring Diagram	33

Contents - continued

Topic	Page
Single Phase Wiring Diagram	33
End & Intermediate Control Wiring Diagrams: Three Phase.	34
Three Phase Wiring Diagram: 220/230V.	34
Three Phase Wiring Diagram: 380/415 V.	34
Parts Listings.	35
200# Hopper Components	35
Feeder Line Components	35
MODEL ATF™PLUS Pan Components	36
Optional Parts	37
Power Unit Components.	38
MODEL ATF™ PLUS Control Unit Components (Sensor Plus) Part # 49148.	39
Drop Tube Assembly: Part No. 49147	41
Single Boot Components: Part No. 6821	42
Twin Boot Components: Part No. 8460	42
Winch (Part No. 47687)	42
Feed Level Tube Winch Kit: Part No. 46218.	43
Miscellaneous Suspension Components.	44
Maintaining the MODEL ATF™ PLUS Feeding System.	45
SENSOR PLUS Sensor Switch Adjustment for Control Units	46
Trouble Shooting the MODEL ATF™ PLUS Feeding System	47

About This Manual

The intent of this manual is to help you in two ways. One is to follow step-by-step in the order of assembly of your product. The other way is for easy reference if you have questions in a particular area.

Important: Read **ALL** instructions carefully before starting construction.

Important: Pay particular attention to all **SAFETY** information.

- *Metric measurements are shown in millimeters and in brackets, unless otherwise specified. “ ” equals inches and “ ’ ” equals feet in English measurements.*

Examples:

1" [25.4]

4' [1 219]

- Optional equipment contains necessary instructions for assembly or operation.
- Very small numbers near an illustration (*i.e.*, 1257-48) are identification of the graphic, not a part number.

Safety Information

Caution, Warning and Danger Decals have been placed on the equipment to warn of potentially dangerous situations. Care should be taken to keep this information intact and easy to read at all times. Replace missing or damaged safety decals immediately.

Using the equipment for purposes other than specified in this manual may cause personal injury and/or damage to the equipment.

Safety–Alert Symbol



This is a safety–alert symbol. When you see this symbol on your equipment, be alert to the potential for personal injury. This equipment is designed to be installed and operated as safely as possible...however, hazards do exist.

Understanding Signal Words

Signal words are used in conjunction with the safety–alert symbol to identify the severity of the warning.



DANGER indicates an imminently hazardous situation which, if not avoided, **WILL** result in death or serious injury.



WARNING indicates a potentially hazardous situation which, if not avoided, **COULD** result in death or serious injury.



CAUTION indicates a hazardous situation which, if not avoided, **MAY** result in minor or moderate injury.

Safety Instructions

Follow Safety Instructions

Carefully read all safety messages in this manual and on your equipment safety signs. Follow recommended precautions and safe operating practices.

Keep safety signs in good condition. Replace missing or damaged safety signs.

Decal Descriptions

DANGER: Moving Auger

This decal is placed on the Panel Weldment.

Severe personal injury will result, if the electrical power is not disconnected, prior to servicing the equipment.

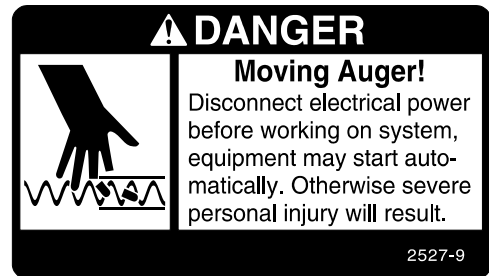

DANGER: Electrical Hazard

Disconnect electrical power before inspecting or servicing equipment unless maintenance instructions specifically state otherwise.

Ground all electrical equipment for safety.

All electrical wiring must be done by a qualified electrician in accordance with local and national electric codes.

Ground all non-current carrying metal parts to guard against electrical shock.

With the exception of motor overload protection, electrical disconnects and over current protection are not supplied with the equipment.

CAUTION:

Use caution when working with the Auger—springing Auger may cause personal injury.

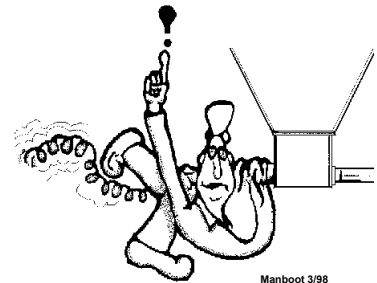
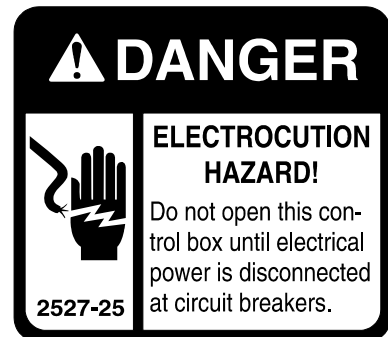

General

Support Information

The Chore-Time MODEL ATF™ PLUS Feeding System has been designed to feed poultry. Using this equipment for any other purpose or in a way not within the operating recommendations specified in this manual will void the warranty and may cause personal injury.

This manual is designed to provide comprehensive planning and installation information. The Table of Contents provides a convenient overview of the information in this manual.

MODEL ATF™ PLUS Recommendations & Guidelines

The Chore-Time Adult Turkey Feeder is recommended for birds 5 to 6 weeks old and over. See the chart for feeder space recommendations.

Adult Tom Turkeys: 45 to 50 birds per pan.

Hen Turkeys: 70 to 80 birds per pan.

Operate the equipment, if possible, before birds are housed to check installation, switch operation, and fill the feeder lines with feed.

The oil coating on new auger will cause the auger to deliver feed at a slower rate. To reduce the load on the motor while the equipment is being broken in, auger 50 pound (20 kg) increments of feed out to the pans. Allow the system to run for approximately 30 seconds, then add another 50 pounds (20 kg) of feed. Repeat this procedure until feed has been supplied to all the pans. Do not feed grit with the Adult Turkey Feeder.

Birds avoid dark or cold areas. Do not locate a Control Unit in such an area. Also, do not locate the Control Unit close to the end of the building. Allow a minimum of 10 feet (3 m) between the Control Unit and the building wall. If these problems are anticipated, they can be corrected during installation. Otherwise, artificial lighting can partially correct the problem.

During the break-in period, check the feed level in the pans. Normally, 1" to 1-1/2" (25 to 38 mm) of feed in the pan controls feed waste. When birds are housed, monitor the feed level in the pans and adjust as needed. Note: When birds are debeaked, a deeper feed level is required. Adjust the feed level by raising or lowering the Feed Level Tube in the Feed Level Ring.

The height of the feeder line can be adjusted easily and it should be raised periodically as birds grow. Keep the lip of the pan approximately at the point where the bird's neck joins the breast so that the birds must reach slightly. For the average 20 pound (9.1 kg) turkey, this will put the lip of the pan about 16 to 18 inches (405 to 455 mm) above the floor. Keeping the pans high results in less feed waste, less litter in pans, and easier bird movement.

Glossary of Terms

Sensor Plus control:

Electronic Switch

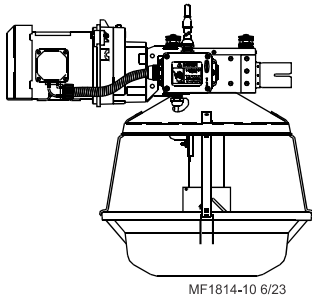

MF1814-10 6/23

A feeder, equipped with a switch, (located at the power unit), used to control the feeding system.

End control:

Mechanical Switch

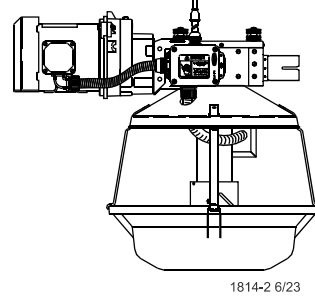

1814-2 6/23

A feeder, equipped with a switch, (located at the power unit), used to control the feeding system.

Clamp:

A two-piece, riveted strap used to secure auger tubes together.

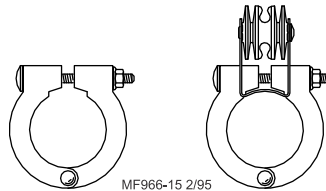

MF966-15 2/95

Anti-Roost Bracket:

An insulator and bracket assembly mounted on every fourth or fifth clamp to support shocker wire.

Adjustment Leveler:

A cable locking device used to conveniently adjust the feeder to a level position.

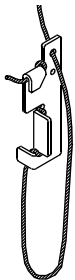

MF232-59 6/23

Drop Line:

A section of cable fastened to the main cable, routed through a pulley, down to the feeder line.

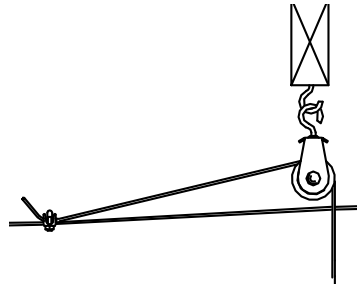

Throw-back:

A cable/pulley arrangement that allows cable to be routed to a desired location.

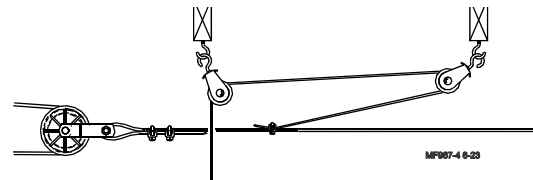

MF087-4 6-23

Double-back:

A cable/pulley arrangement that reduces the load on the Power Winch.

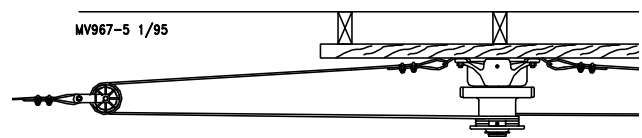

MV967-5 1/95

Power Lift:

Red, cast iron winch used to raise and lower the feeder line(s). Operated by a hand crank or electric drill. Referred to as Power Winch.

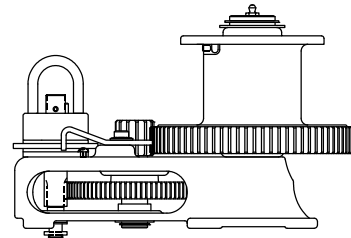

Electro-Guard:

A high voltage, low current shocking device used to keep birds from setting on the feeder line.

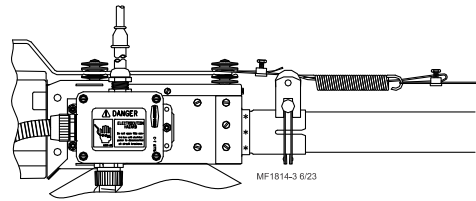

Planning the Floor Feeding System

1. Select the House Layout.

A. Optional Mid Line Controls may be used for partial house brooding, see **figure 1**.

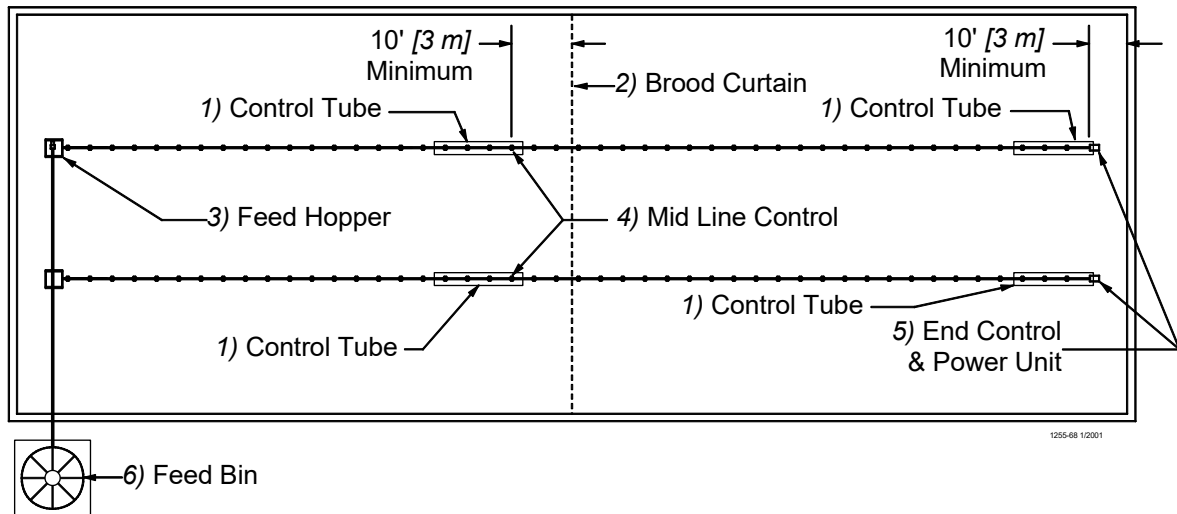

Figure 1.Component location diagram for systems up to 400 feet [122 m]. (Top View).

B. Systems with line lengths over 400' [122 m] should be split in the center, as shown in **Figure 2**. This will reduce auger running time and eliminate the need for Mid-Line Controls for partial house brooding.

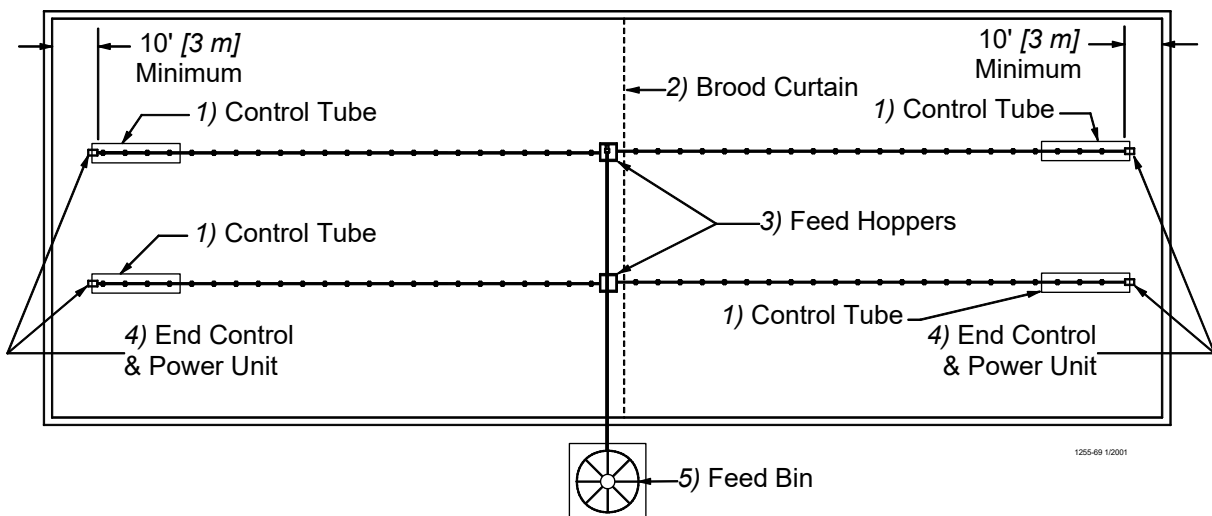

Figure 2. Component location diagram for systems over 400 feet [122 m]. (Top View).

2. Determine the Feed Bin location.
3. Determine the Brood Curtain location.

4. Determine the location for the End Control Pans, and if used the Mid Line Control Pans. **The Feeder Control Pans** should be at least 10' [3 m] from the Wall or Brood Curtain.
 5. Determine the distance to the Feeder Line from the Side Wall.
- Determine the distance from the Feed Hoppers to the End Wall for a Straight Line Feeding System.

Suspension System

The feeder line suspension system is a vital part of your feeding system. Proper planning and installation is necessary to insure proper operation of the system. Use the chart below as a reference guide for determining support load requirements for your system.

Component	Weigh in pounds (kg)
Tube, Auger, Feeders, & Feed	9 lbs./ft (13.4 kg./m)
Power Unit & Control Unit Assembly	50 lbs. (22.6 kg)
200 lb. Feed Hopper & Feed	250 lbs. (113.4 kg)
Power Winch	40 lbs. (18.1 kg)

The type of installation required depends on feeder line length. **Figure 4** shows the suspension system for feeder line lengths to 350' (107 m). **Figure 3** shows the suspension system for feeder lines over 350' (107 m).

IMPORTANT: Notice that the feeder line MUST BE SUPPORTED WITHIN 1 FOOT (300 MM) OF THE HOPPER AND 3 FEET (1 M) OF THE MOTOR ON THE CONTROL UNIT. If the Control Unit does not come out directly under a truss, fasten a pulley to a 2x8 (50x200 mm) board or other fixture that will span 2 trusses supporting the Control Unit.

After determining the type of suspension system required, decide where the feeder line is to be installed. Mark a straight line on the ceiling or rafters the full length of the feeder line. Use a string, chalk line, or the winch cable, temporarily attached with staples, to mark the line. Center the line directly over where the feeder is to be installed.

The recommended distance between the drops is 8' (2.4 m) on center. Do not exceed 10' (3 m) spacing on drop lines.

If the distance raised is greater than the distance between the drop spacings, offset the hooks 3" (75 mm) to each side of the line to prevent the cable clamps from catching the pulleys, **see figure 5**.

For installations using wood trusses, standard screw hook or the optional Ceiling Hook may be used to hold the pulley assemblies.

For installations using steel trusses, the Ceiling Hooks are available to hold the pulley assemblies.

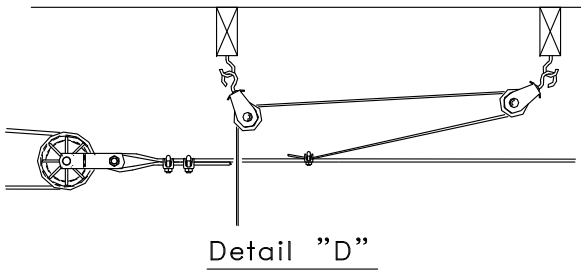
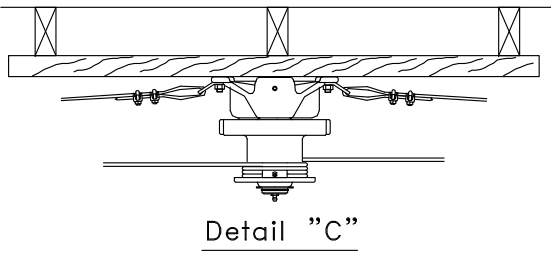
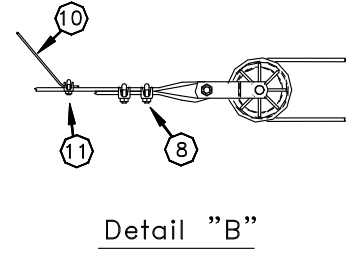
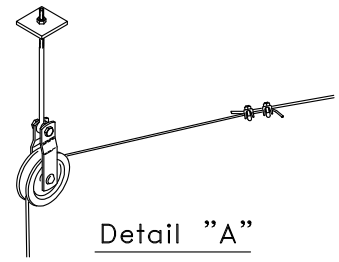
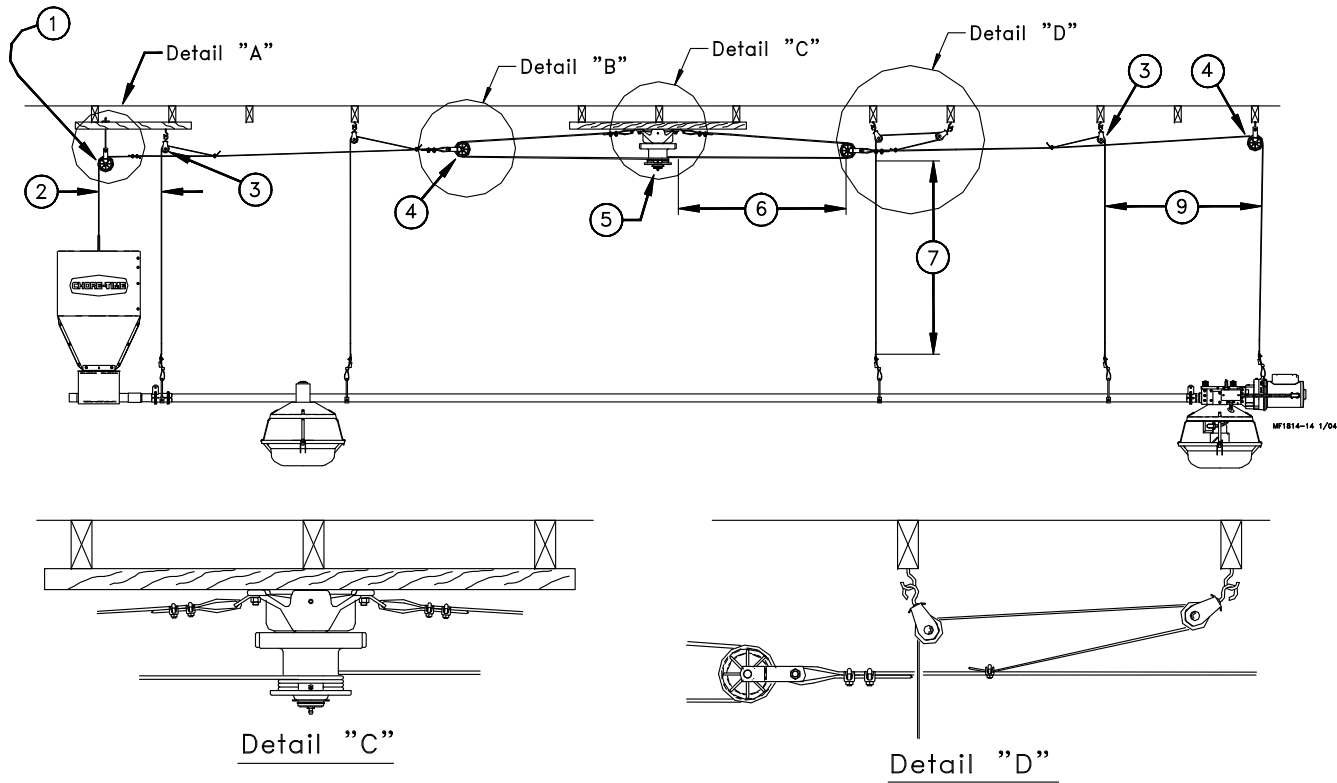

Figure 3. For Systems over 350' (107 m)

Key	Description
1	Full Line Suspension Kit
2	1' (30 cm) maximum
3	Swivel Pulley
4	3.5" (8.9 cm) Pulley
5	Power Winch
6	Key #7 + 2' (61 cm)
7	Maximum Distance of Travel
8	Double Clamp Here
9	3' (90 cm) Maximum
10	Drop Line
11	Single Clamp Here

Suspension System Offset

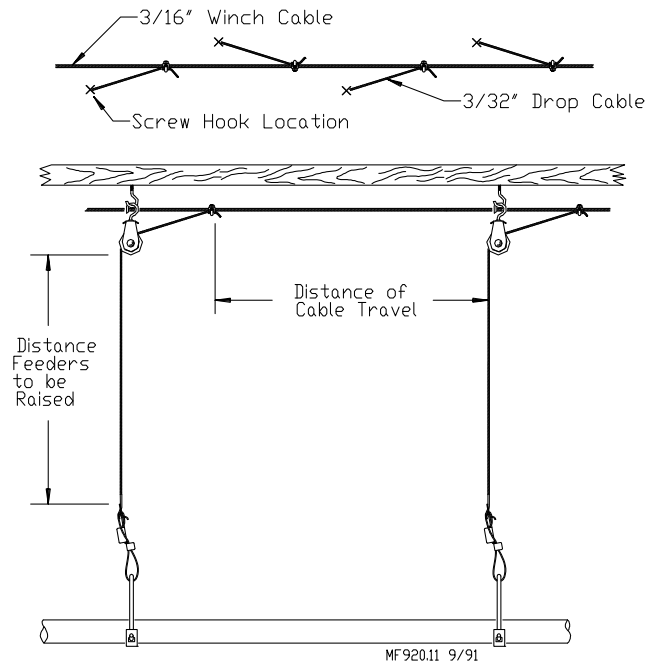

Figure 5. Suspension System with Off-Sets

Screw Hook Installation

Screw the hook into the truss the full length of the threads to prevent bending. The openings of the screw hooks must be pointed away from the direction of travel when the Power Winch raises the feeder line, see figure 6.

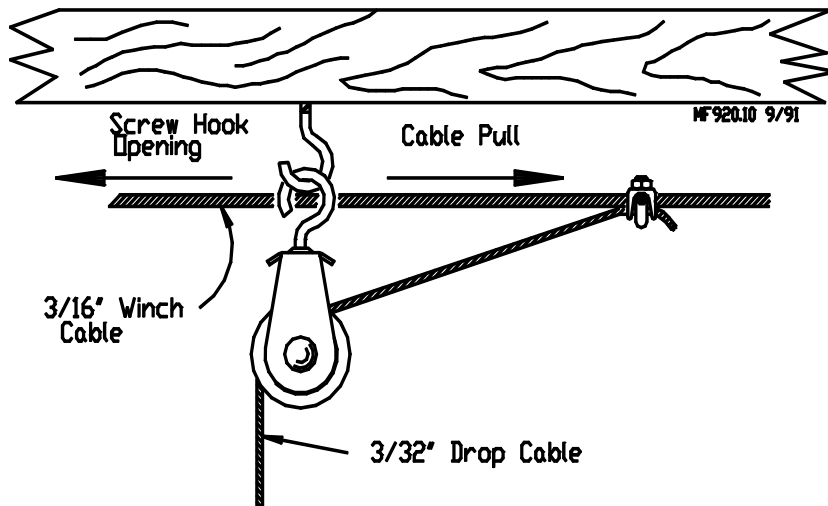
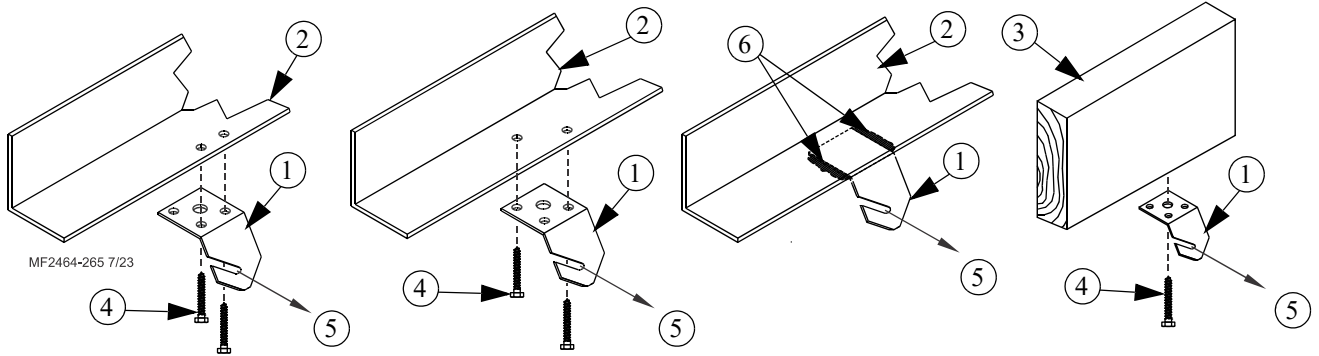

Figure 6. Screw Hook Installation

Ceiling Hook Installation



MF2464-265 7/23

Item	Description	Part No.
1	Ceiling Hook	28550
2	Steel Truss	--
3	Wood Truss	
4	1/4-20 Lag Screw	--
5	Cable Travel Direction	--
6	Weld	--

Figure 1.Ceiling Hook Installation

Swivel Pulley Installation

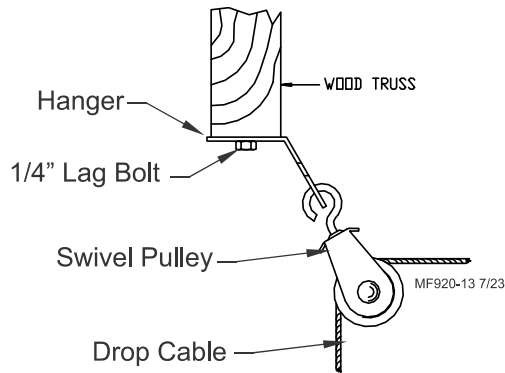

MF920-13 7/23

Figure 7.Swivel Pulley Install

Power Winch Installation

1. Bolt the Power Winch, fully assembled, to a 2x8 (50x200 mm) board or other fixture that will span at least 3 rafters. The brake mechanism will protrude on one side.

For feeder lines over 350 feet (106 m), install a 2985 Cable Hook between the mounting bolt and Power Winch frame, as shown in Figure 22.

2. Attach the 2x8 (20x200 mm) board, with the Power Winch secured, to the ceiling at the center of the feeder line. The 2x8 (50x200 mm) or other fixture must be parallel to the line and must span at least 3 rafters or other fixture.

If the hopper is located at the center of the feeder line, locate the Power Winch a few feet offset from the center of the feeder line.

3. Extend the 3/16" (5 mm) cable the full length of the feeder line. Attach the cable temporarily to the ceiling with nails, staples, or some type of fastener.
4. Wrap the cable through the winch drum relief located near the bottom of the drum. Tighten the set screw to anchor the cable to the drum, **see figure 9**.
5. Turn the winch drum one full revolution. Guide the cable against the flange at the bottom of the winch drum. The cable must not wrap over itself on the drum, but should be wrapped as close as possible to each previous wrap, **see figure 9**.

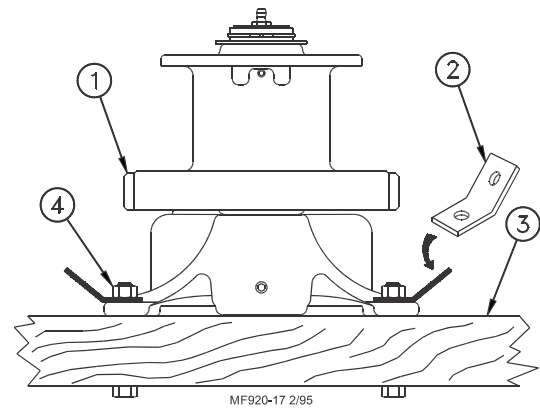

Figure 8. Power Winch Installation

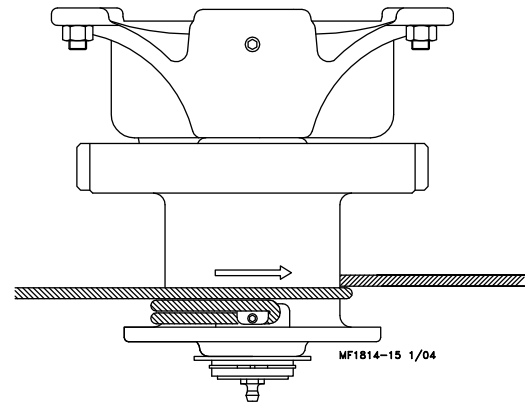
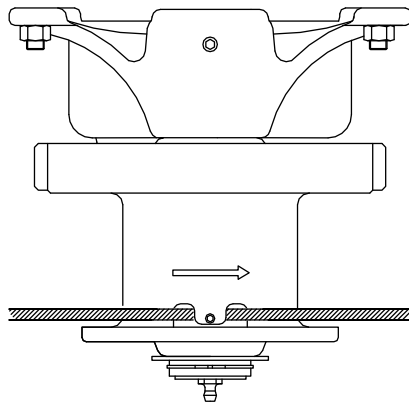

Figure 9. Cable Installation & Wrap

Drop Installation

1. Attach a 3004 Pulley to each hook.
2. Thread the end of the 3/32" cable through the pulley toward the winch. Clamp this end to the 3/16" winch cable about 6" (150 mm) from the pulley, using a 3/16" cable clamp, **see figure 6**.
3. Cut the cable long enough to allow for installation to the feeder line and to the Adjustment Leveler.

Sufficient cable is included to provide "throwbacks" on drops located beneath and near the winch. **See figure 3 (on page 11)**, Detail D shows a "throwback" cable arrangement.
4. **Begin installing suspension drops at the winch and proceed to the ends of the feeder line.**

Keep the main cable tight between drops. It may be necessary to hang a weight on the end of the main cable to maintain tension.

Hopper Assembly Procedure

The 200# Hopper is used with the MODEL ATF™ PLUS feeding system.

1. Loosely, assemble the 200# Hopper Side Panels, as shown in **Figure 10**, using 1/4-20 bolts and 1/4-20 hex nuts (supplied in Hardware Package). The Hopper should be assembled so that the "CHORE-TIME" decals are on opposite sides of the hopper.
2. Secure the Boot Hangers to the bottom of the hopper, using 1/4-20 hardware, **see figure 10**.

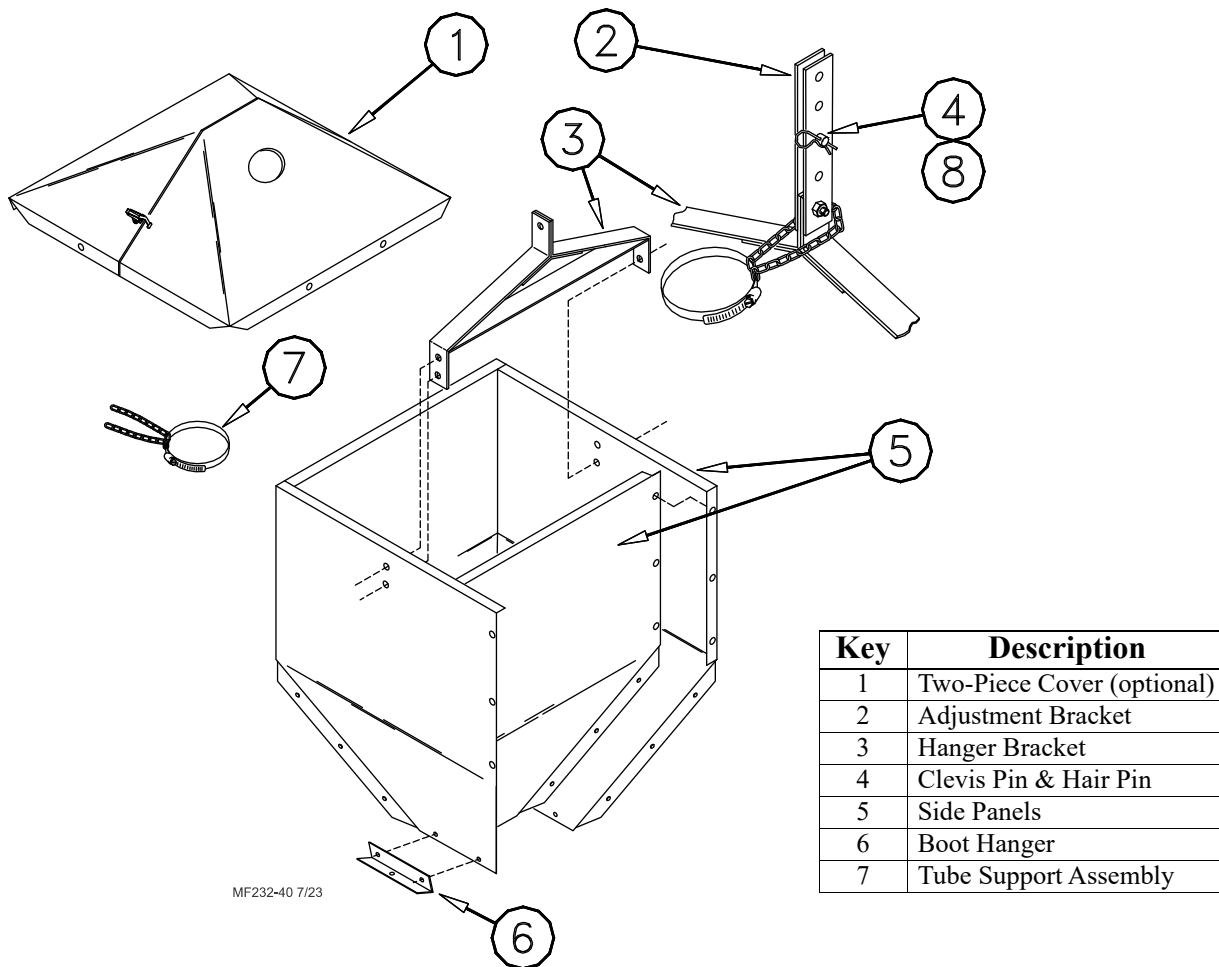

Figure 10. Hopper Assembly Procedure

Feeder Assembly

MODEL ATF™ PLUS Feeding System

1. Attach (4) pan supports to the pan shield using the (4) carriage bolts and plastic lock nuts. Then tighten the nuts.

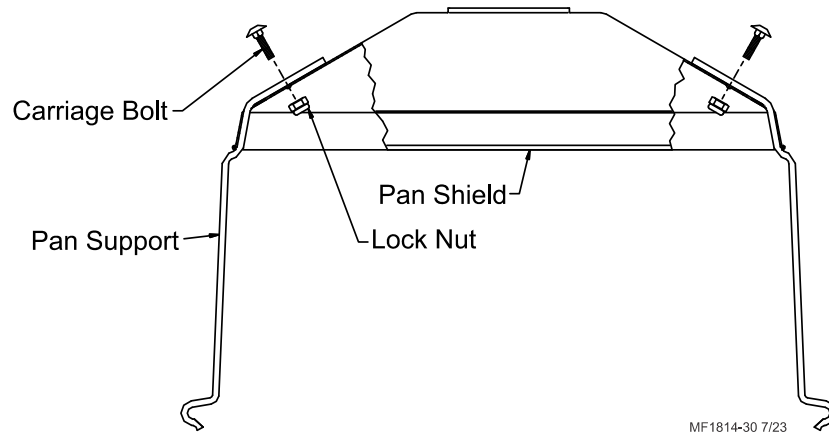

Figure 11. Pan Shield Assembly

2. Determine which Feeder Pan (Adult Turkey or Steel) is to be installed, see figure 12.

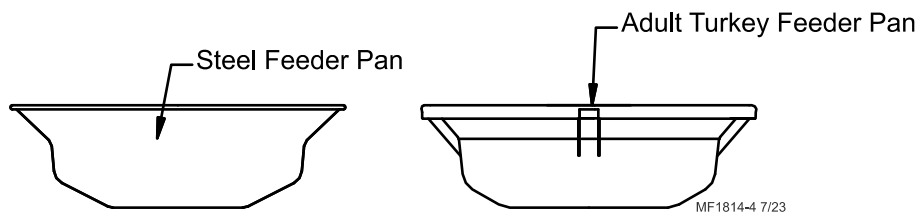

Figure 12. Feeder Pans

3. Assemble the feed level tube and feed level ring as shown, see figure 13.

- Note the direction of the arrow on the side of the feed level tube.
- Position the feed level ring in the third hole from the bottom for the plastic adult turkey feeder pan.
- Position the feed level ring in the fourth hole from the top for the steel adult turkey feeder pan, see figure 13.

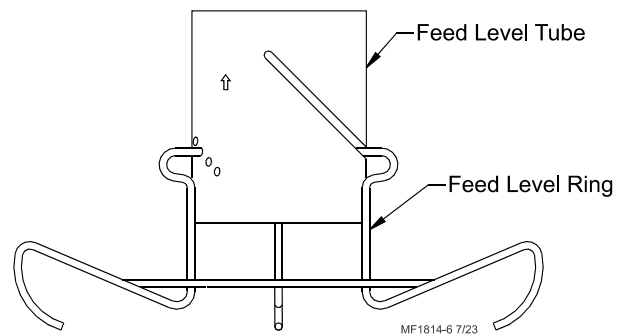

Figure 13. Adult Turkey Feeder Feed Level Ring Plastic Pan

4. If the feed level tubes are to be winch adjustable, install the cable assemblies at this point. If the feed level tubes are not to be winchable, proceed to step 5.

Before installing the cable assemblies a 90 degree bend needs to be put in the cable to keep all the feed level tube assemblies at a uniform height, To do this take a pair of needle nose pliers and grab the cable behind the cable stop. Now bend the cable over the pliers back onto itself, see figure 14.

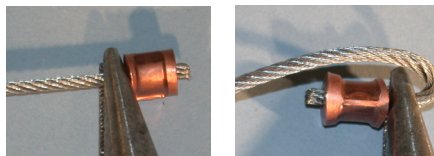

Figure 14. Cable

Install two cables at each feed level tube as shown, **see figure 15**. The cable stop should be located on the inside of the feed level tube and pulled up tight against the inside.

NOTE: After the feeder operates, re-adjustment of the feed level tubes may be done to achieve the desired feed level.

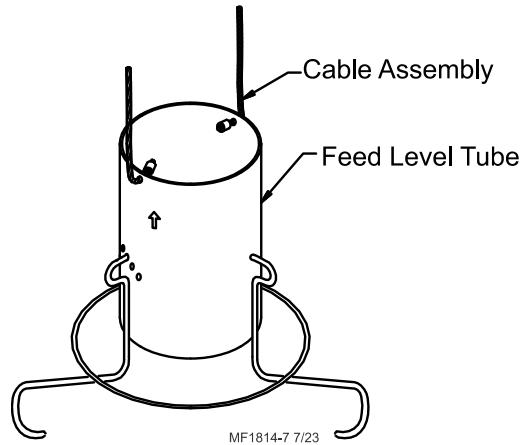

Figure 15. Cable Installation

5. Place the feed level tube assembly in the feeder pan.
6. Insert drop tube into feed level tube assembly, **see figure 16**. Install the pan shield supports in the slots in the drop tube.
7. With the bottom of the pan up, hook the swing down pan support. Then rotate the pan down to hook the remaining pan supports over the lip of the pan.

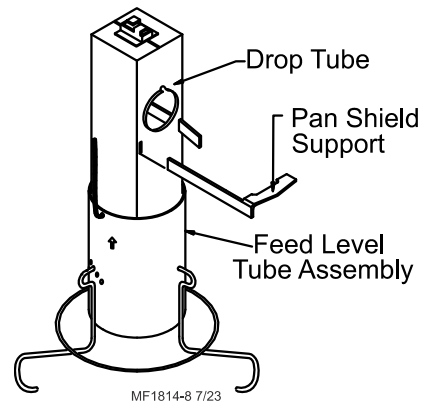

Figure 16. Drop Tube Installation

Do not bend the pan supports during assembly.

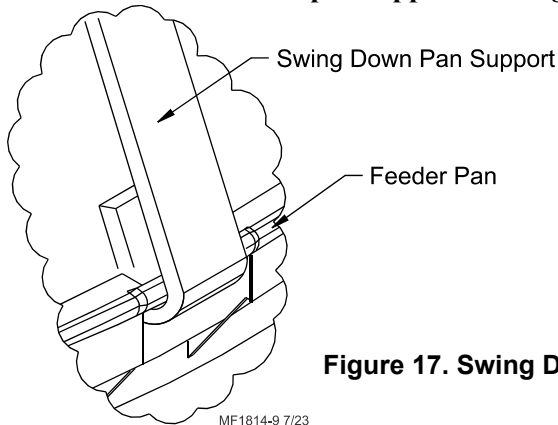

Figure 17. Swing Down Pan Support

Feeder Tube Assembly

1. Slide one Pan Assembly onto the Feeder Tube for each outlet hole. Lift the Drop Tube through the Pan Shield so the Feeder Tube can slide through the holes in the sides of the Drop Tube. Install the Pan Assemblies so that all the Swing Down Pan Supports are on the same side of the feeder line.
2. Rotate the feeder Tube so that the tab at the outlet hole will pass through the notch in the Drop Tube. Rotate the tube 180 degrees to lock the pans in place, **see figure 18**. Make sure outlet holes are down.
3. Position the tubes with pans attached end to end in the approximate location where they will be suspended. **The belled ends of the tubes must point towards the hopper.**

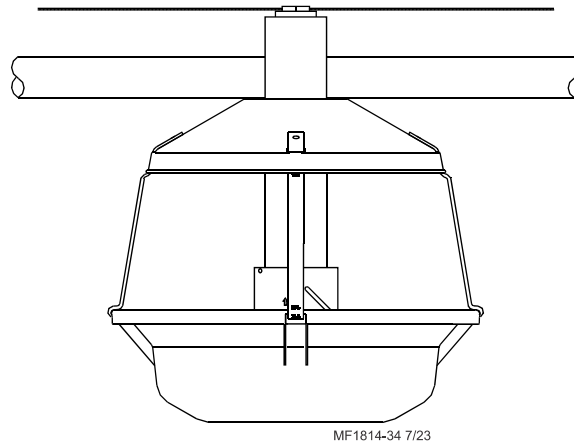

Figure 18. Install Feeders on Tubes

Feeder Line Assembly & Suspension

Feeder Line Installation

1. The tubes should be laying end to end in approximately the final location of the line. The expanded end of each tube should be toward the hopper end of the line, **see figure 19**.
2. Connect the individual feeder tubes together by inserting the straight end of the tube as far as possible into the belled end of the next tube.

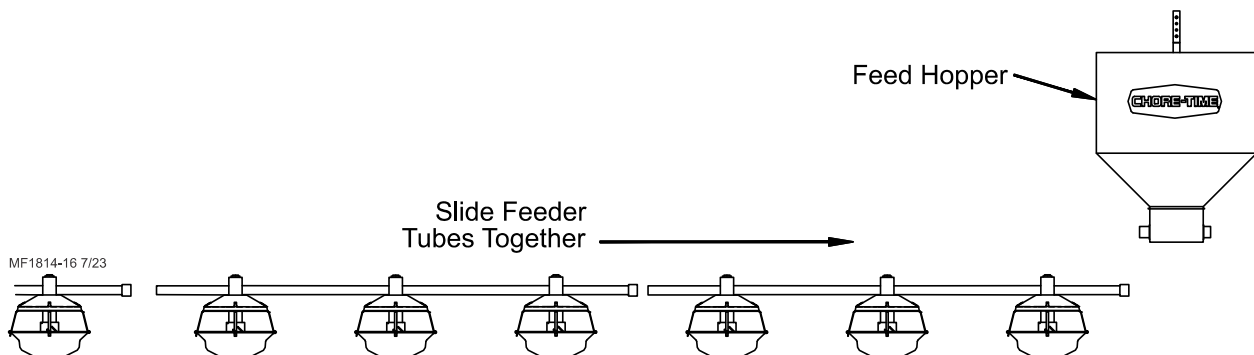

Figure 19. Feeder Line Assembly Procedure

3. Place a Tube Clamp Assembly **or** Clamp/Anti-Roost Bracket at each joint. **Figure 20** shows the standard Clamp and Clamp/Anti-Roost Bracket.

Make sure that each tube fits as far as possible into the belled end of the next tube. The outlet holes **must point down**. Install tube clamps as shown in **Figure 21**.

4. Begin at the hopper end of the line. Use a tube clamp with anti-roost bracket to attach the hopper to the first tube. Use a tube clamp (w/o insulator) at the next joint--between the first and second feeder tubes. Continue down the line, clamping the tubes together. Use a tube clamp with anti-roost bracket at the end of the line. This should give a tube cable clamp with anti-roost bracket at each end of the line and at 20 foot (6 m) intervals along the length of the line.

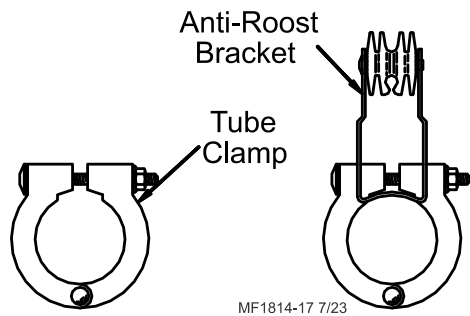

Figure 20. Tube Clamp & Anti-Roost Bracket

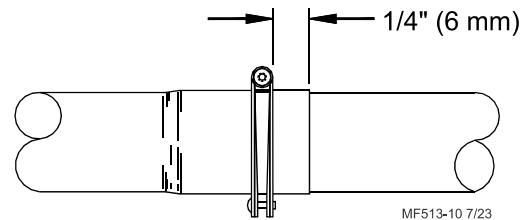

Figure 21. Tube Joint Connection

5. Install the Hangers on the tubes on the 8' (2.4 m) spacings determined by the suspension drop lines. **Figure 22** shows the proper installation of the Hanger Assembly. Make sure the outlet drop hole is down when the Hangers are installed, otherwise feed will not be allowed to drop into the feeder pan.

6. Install Adjustment Leveler within 6" (152 mm) of feeder line hanger. **Figure 22** shows the proper cable routing around the Adjustment Leveler.

7. Following installation of all drops, check drop cables before raising feeder line. Cable must be on all pulleys before raising the feeder line.

8. Raise the feeder line to a convenient working height.

9. After the feeder line has been suspended, level the system to the bird walking surface.

10. Before tightening each clamp;

- make sure each tube is level (not sagging, sloping, etc.).
- make sure straight end of tube is fully inserted in belled end of next tube.
- make sure clamp is located, as shown in **Figure 21**.

11. Finally, tighten the Tube Clamps on the feeder tubes. Clamp the joints securely, **but do not crush the tubes**.

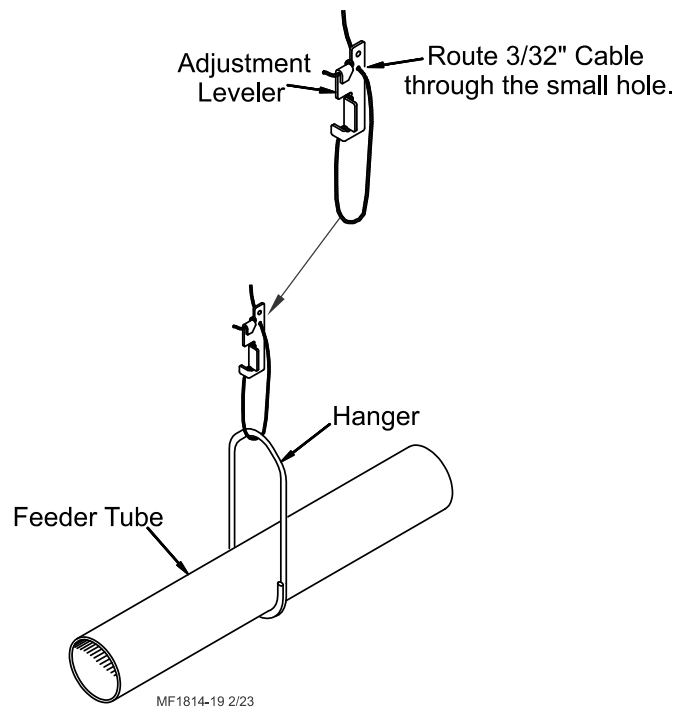

Figure 22. Adjustment Leveler & Hanger Assembly

Control Unit Installation

The assembly instructions are very similar for the 49148 Control Assembly and the 49146 Control Assembly. The primary differences between the controls are in the electrical components and protection devices.

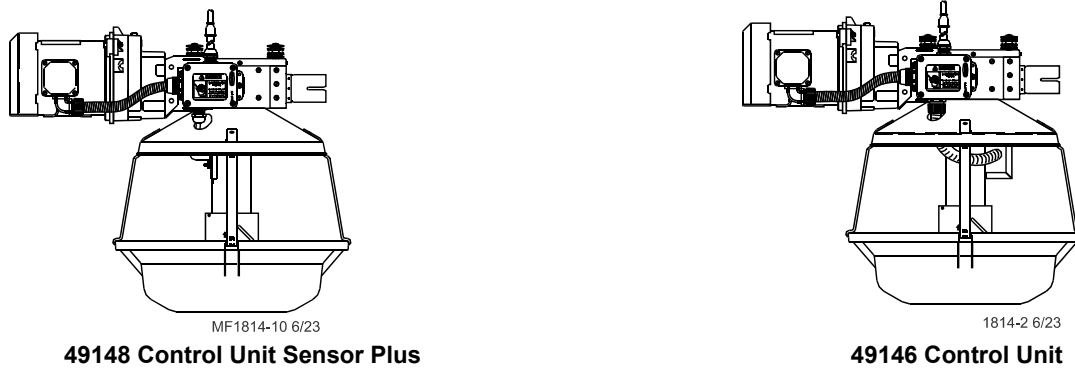

Figure 23. Control Units

1. Remove the four 5/16-18x5/8" bolts from the parts package and use them to bolt the Anchor Plate to the Power Unit. Install the Anchor Plate with the angled end pointing down, see figure 24.
2. Bolt the Control Unit Body Assembly to the Power Unit, using hardware supplied, see figure 24.

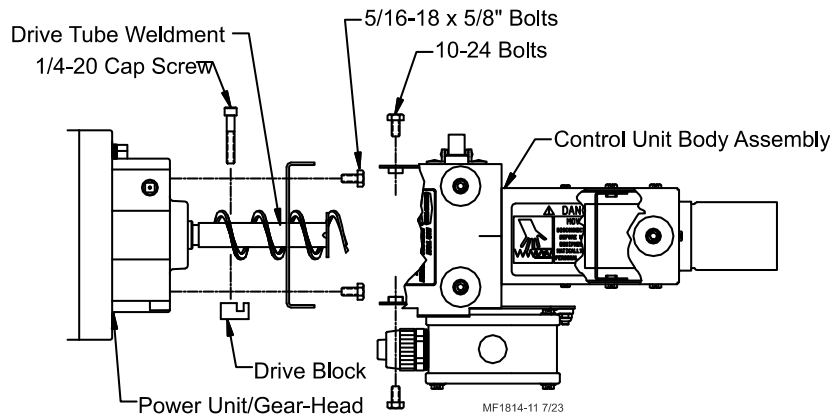

Figure 24. Control to Power Unit Ass'y

3. Bolt the pan support to the pan shield. See figure 11 (on page 17) for instructions on bolting.
4. The Feed Level Switch is factory adjusted. To check adjustment before assembling, depress the switch paddle and listen for the switch to "click". If the switch needs adjustment, See "Maintaining the MODEL ATF™ PLUS Feeding System" on page 45.
5. Insert the Drop Tube and Switch Assembly through the Pan Shield, from the bottom, see figure 25. The hole in the Pan Shield should be located on the same side of the Drop Tube as the Switch Cord and directly under the white box on the body assembly. Bolt the Drop Tube to the Body Assembly. The switch on the Drop Tube should be mounted opposite the Power Unit.

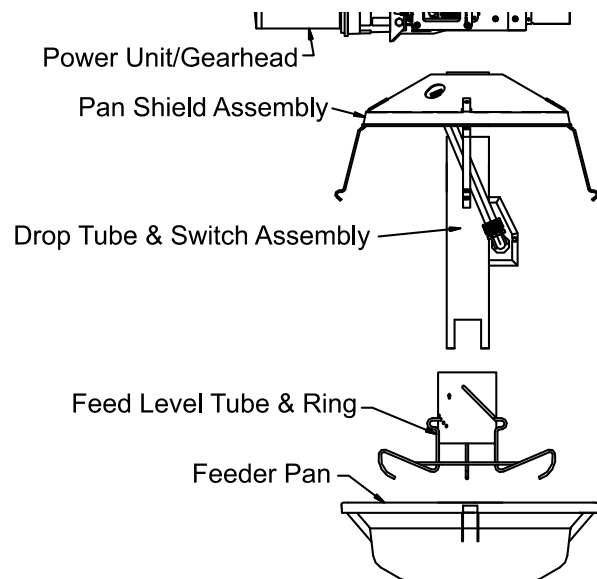

Figure 25. Drop Tube & Switch Assembly

6. Single Phase: Install the 90 degree connector, flexible conduit, electrical wire, and conduit connector, **see figure 26.**

Three Phase: Refer to applicable electrical standards for connecting Power Unit to Control Unit. Components are not supplied by Chore-Time.

7. Insert the flex cable that is attached to the control switch through the hole in the control unit pan shield and attach the Romex connector to the handy box, **see figure 27.**

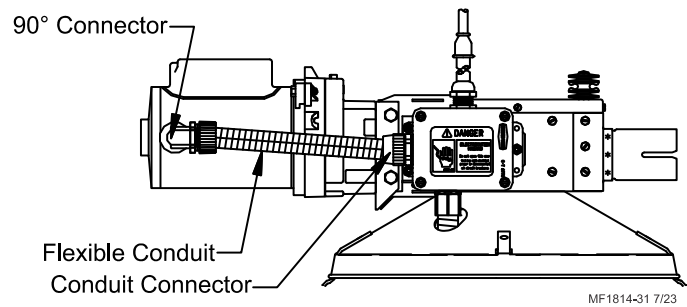

Figure 26. Conduit Installation

8. DISCONNECT ELECTRICAL POWER PRIOR TO WIRING THE CONTROL UNIT.

Single Phase Control Unit may be wired as shown in the wiring diagrams on page 33.

Three Phase Control Unit must be wired as shown in the wiring diagrams on page 34.

9. Mount the control unit on the end of the feeder line and secure with a tube clamp. **See figure 24 (on page 21).** The distance between the control unit pan and the last pan should be five feet (1.5 m) or less.

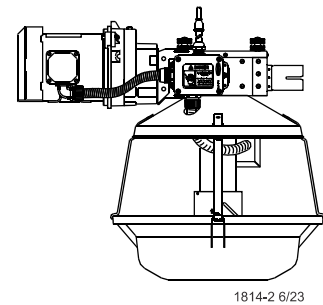
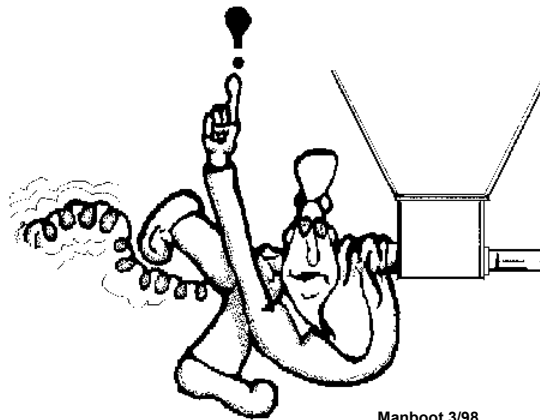

Figure 27. Switch Installation

Auger Installation

Note: Use extreme caution when working with the auger. The auger is under tension and may spring causing personal injury. Wear protective clothing, gloves, and safety glasses when working with the auger.



Manboot 3/98

BE CAREFUL WHEN WORKING WITH AUGER!

To avoid kinking the auger, be careful not to drop the rolled auger when handling. Inspect the auger carefully as it is installed. Small kinks may be straightened. Large kinks must be removed and the auger brazed back together.

Cut the leading 18" (450 mm) and last 18" (450 mm) off each roll of auger. Also, cut out any other distorted auger sections and reconnect the auger as specified in the Auger Brazing section of this manual.

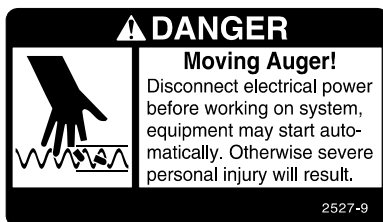

1. Remove the Anchor & Bearing Assembly from the boot under the Hopper.
2. **Use extreme caution when pushing the auger into the auger tubes. Keep your hand away from the end of the auger tube to avoid injury.**
 With the auger coiled about 6 feet (1.8 m) from the end of the boot, feed the auger through the boot into the tubes. Push the auger into the tube in short strokes.
 Uncoil and handle the auger carefully to avoid damaging or kinking the auger.
3. If more than one coil is required for each feeder line, the auger ends will have to be brazed together. Refer to the Brazing the Auger section in this manual.
4. Continue installing auger until the auger reaches the Control Unit end of the feeder line.

5. Slide the Drive Tube and flat washer over the output shaft on the Power Unit, as shown in **Figure 28**.
6. Attach the auger to the output shaft of the Power Unit. Use the Drive Block to secure the auger to the Output Shaft.

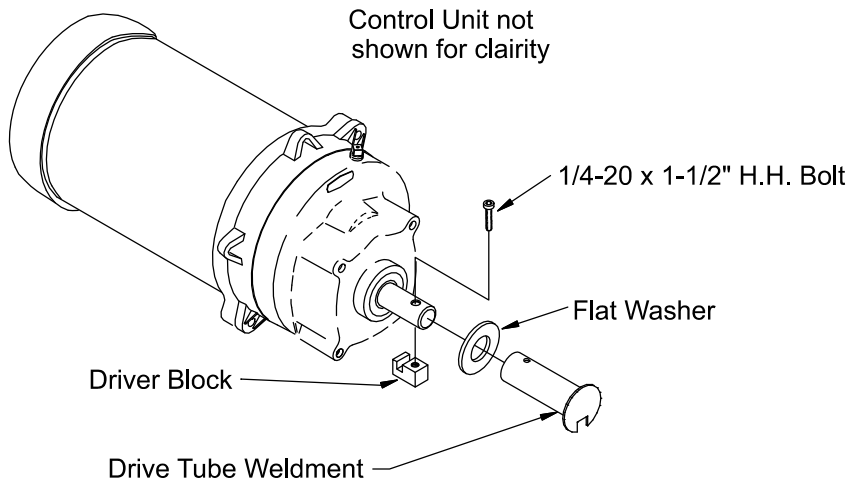
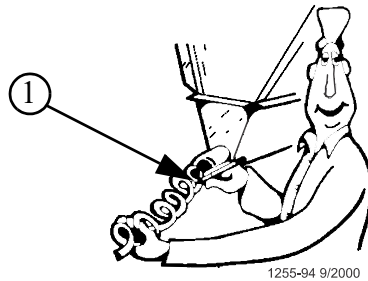

Figure 28. Auger Driver Components

7. Pull the auger at the boot end until it begins stretching. Then let it relax. In the *relaxed* position, mark the auger at the end of the boot, see **figure 29**.



Key	Description
1	Mark the relaxed auger at the end of the boot.

Figure 29. Marking the Relaxed Auger

Auger stretch:



The auger needs to be stretched 7" (180 mm) per 100' (30 m). Example: A 300' (90 m) feeder line requires 21" (500 mm) of stretch.

Beginning at the *relaxed* position, measure the required amount of stretch. Mark the auger at that point.

Grip the auger 8" (200 mm) ahead of this mark with locking pliers. Allow the auger to pull back into the boot so that the pliers rest against the end of the boot, **see figure 30**.

Use a hacksaw or bolt cutters to cut the auger at the stretched auger mark.

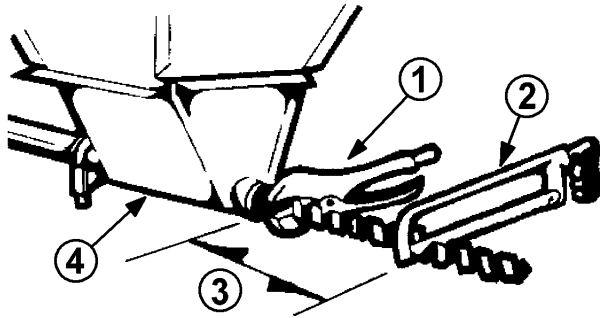

Key	Description
1	Locking Pliers
2	Use a hacksaw or bolt cutters to cut the auger.
3	Pull an extra 8" (200 mm) of auger (minimum) to allow for Anchor & Bearing installation
4	Boot under feed hopper.

Figure 30. Cutting Auger with stretch

9. Insert the Anchor Assembly into the auger, guide the tip of the auger between the two roll pin continue to insert the auger until it touches the washer at the back of the anchor. Tighten the two screws in the center of the anchor.
10. **Carefully** remove the locking pliers while holding onto the Anchor and Bearing Assembly and auger securely. **Slowly** ease the auger back into the tube. **Use caution. If the auger is allowed to spring back, the bearing race may crack.**



11. Install the Bearing Retainer and fasten with a tube clamp. Keep the Bearing Retainer flush with the end of the anchor for safety.

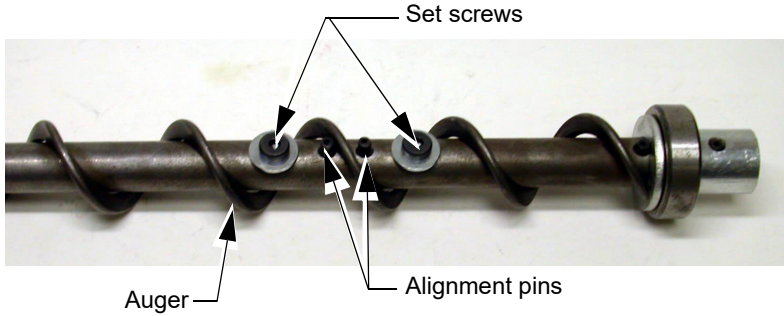

BE CAREFUL WHEN WORKING WITH AUGER!

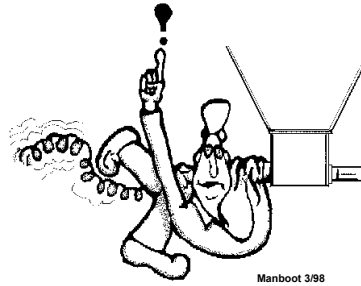

Auger Brazing

The auger should be brazed if it is necessary to splice or lengthen it. A bronze, flux coated rod is recommended.

The ends of the auger should butt against each other, NOT THREAD INSIDE EACH OTHER, see figure 31. The joint should be well filled with no sharp edges or rough corners to wear against the tube. To align the auger for brazing, lay it in angle or channel iron and clamp it firmly in place. Use low heat. Allow the joint to air cool; rapid cooling will cause the auger to become brittle.

Lap the auger ends approximately 1" (25mm).

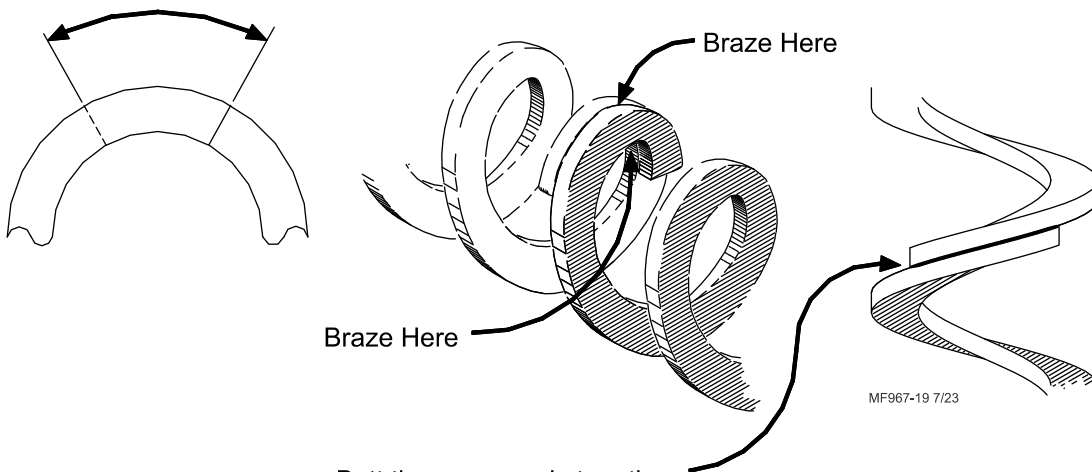

Butt the auger ends together. **DO NOT** thread the auger together.

Figure 31. Auger Brazing

Winch Adjustable Feed Level Tubes (optional equipment)

Chore-Time's MODEL ATF™ PLUS feeding system can be equipped to provide winch adjustable Feed Level Tubes. New systems can be ordered with this feature. Existing system can be (easily) upgraded to include Feed Level Tube winching components.

The Feed Level Tubes are adjusted using a winch and cable. The maximum line length for each winch is 200' (61 m). The winch should be located in the middle of the line of feeders that it is to adjust, **see figure 32**.

Operation

The Feed Level Tubes are winched up to flood the pans with feed to allow maximum access to the feed for young turkeys. As the birds grow, the Feed Level Tubes can be lowered to reduce the feed level.

For systems using the 9194 Feed Level Tubes (winchable), the Feed Level Ring will need to be adjusted manually.

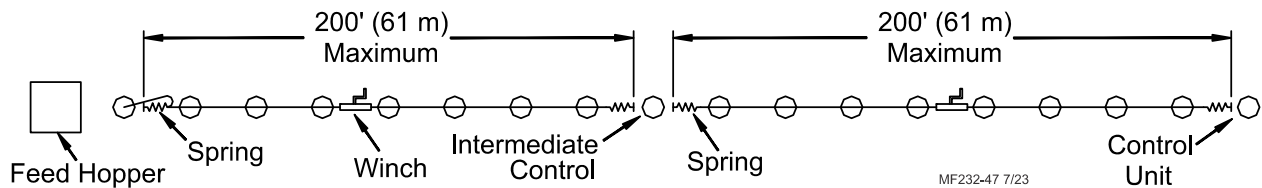

Key	Description
1	200' (61 m) Maximum
2	Feed Hopper
3	Spring
4	Winch
5	Intermediate Control
6	Control Unit

Figure 32. Feed Line Layout

Installation of the Winch Adjustable Feed Level Tube System

1. Use two U-bolts provided to fasten the winch to the feeder line tube, **see figure 33**. The winch should be placed in the center of the line of Feed Level Tubes it will adjust, as shown in **Figure 32**.

THE LINE LENGTH MUST NOT EXCEED 200 FEET (61 M).

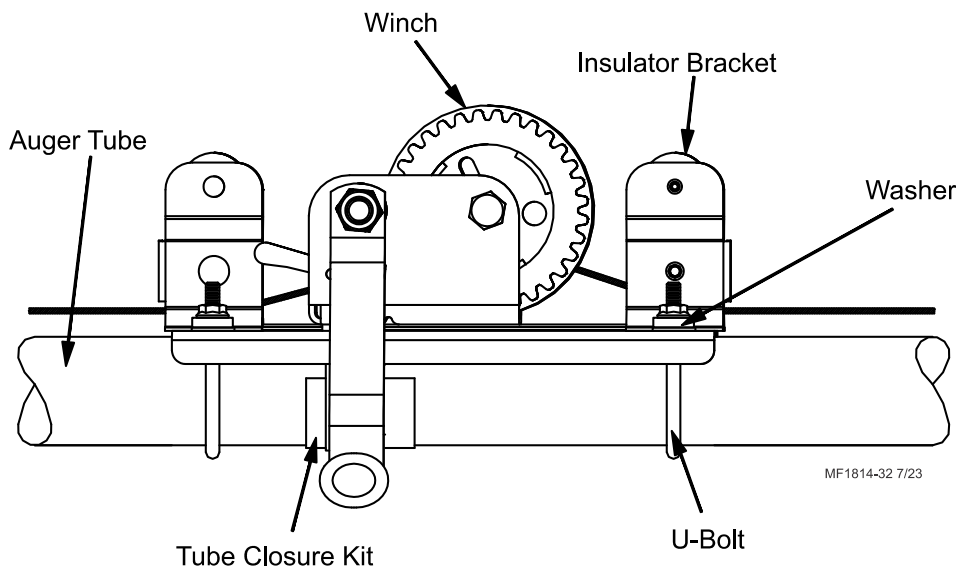

Figure 33. Winch Installation

- Anchor spring to clamp on each side of the winch, see **figure 34**. Attach the Tube Clamp/Spring assemblies to the feeder line tube at a maximum distance of 100 feet (30 m) from the winch, see **figure 32**.

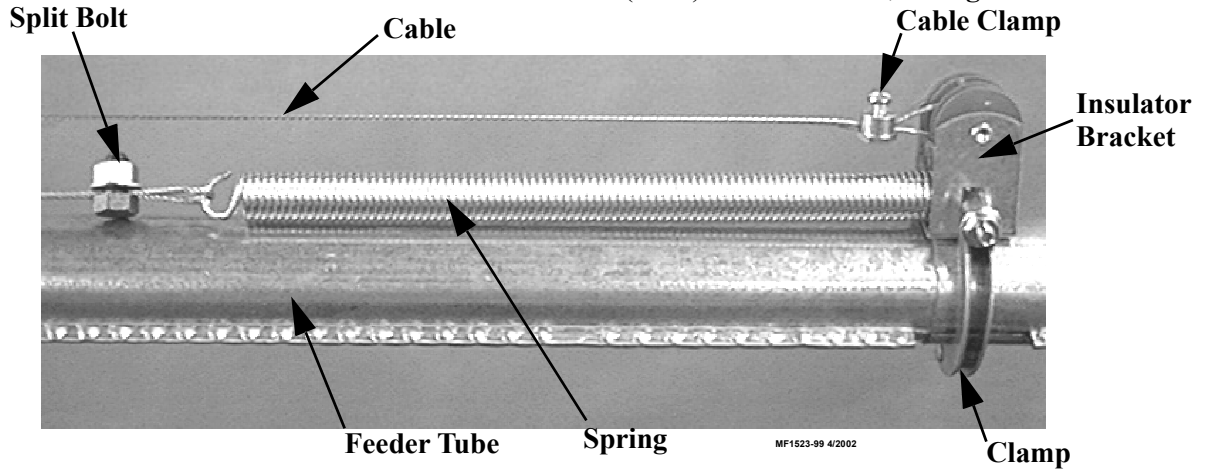

Figure 34. Spring and Insulator Bracket Installation

- Lay the cable through the split in the winch drum. Turn the winch handle clockwise two revolutions to wind some cable onto the winch drum, see **figure 35**.

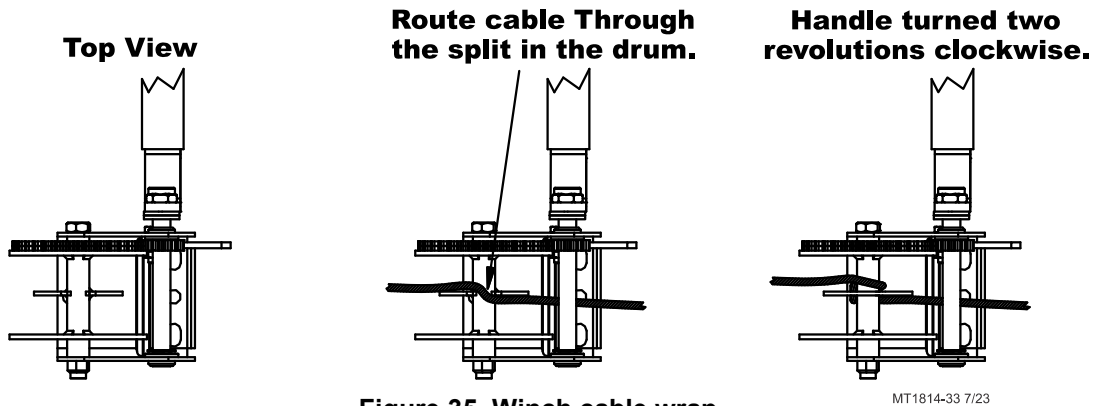

Figure 35. Winch cable wrap

- Thread the cable through every Drop Tube to support the cable and keep it in position, see **figure .**
- Loop the cable around the end of the Spring and secure with a split bolt cable clamp, see **figure 34**.

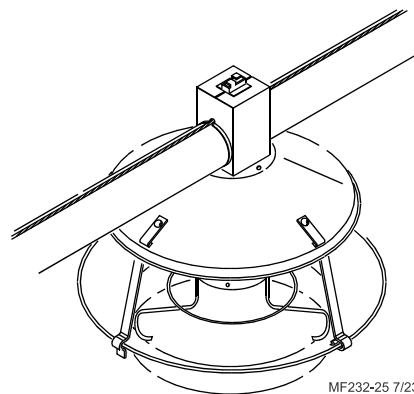

Figure 36. Winch Cable Routing

6. There is not enough room between the feed hopper and the first feeder pan to attach and stretch the spring. Install the spring in between the first and second pan after the hopper. Then route the cable back to the first pan and attach to the feed tube cable assemblies, see **figure 37**.

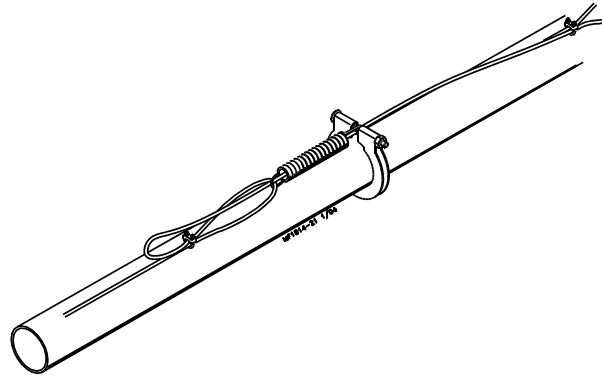

Figure 37. Hopper End Spring Installation

7. Install two cable assemblies at each feed level tube (if the cable assemblies have not yet been installed). The cable stop should be on the inside of the feed level tube and pulled up tight against the inside, See **figure 14** (on page 17) and See **figure 15** (on page 18).

8. Thread the cable assemblies through the holes on each side of the pan shield from the underside. Then clamp to the master cable with a cable clamp, see **figure 38**.

NOTE: Before clamping the cable assemblies to the cable, make sure that:

- a. The springs at each end of the cable are stretched approximately 14" (355.6 mm).
- b. The feed level tubes are raised as high as possible.
- c. The stop on the cable assemblies are pulled up against the inside of the feed level tube.

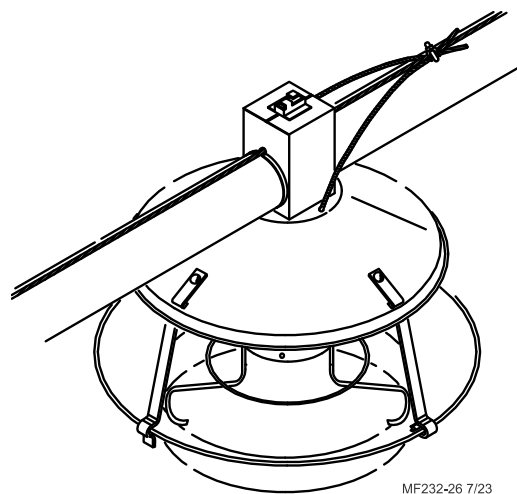

Figure 38. Cable Assembly Installation

Anti-Roost Installation

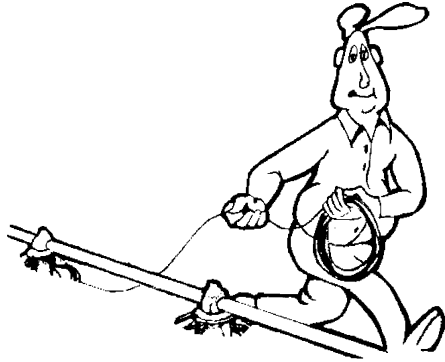

Figure 39. Unrolling the Cable

1. Unroll the bulk anti-roost cable. Note: If the cable is unrolled as shown in **Figure 39**, taking 5 loops of the coil with one hand, then changing hands to remove 5 loops as it is unrolled, it will lie flat during installation.

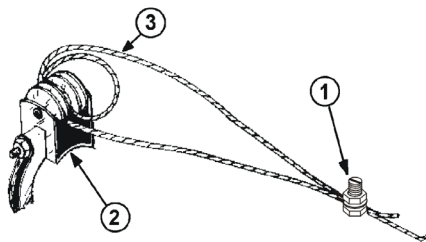
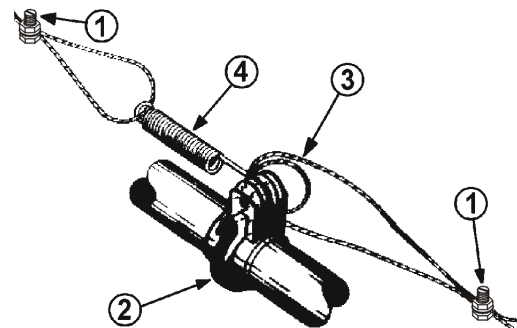

Figure 40. Anti-Roost Cable Installation

2. Start at the hopper end of the line and form a loop around the anti-roost bracket. For best results, make a double loop around the anti-roost insulator in the center groove of the insulator and fasten with a 3/32" cable clamp as shown in **Figure 40**.

Key	Description
1	Cable Clamp
2	Clamp with Anti-Roost Bracket
3	Anti-Roost Cable

3. Insert the cable in the insulator on the top of each Grill Support between the hopper and the next anti-roost bracket.
4. Attach a spring in the center groove at the second anti-roost bracket and cut the cable at this point, **see figure 41**.
5. Thread the ends of the cable through the end of the spring. Pull the cable tight so that there is 3/4" to 1" (20 to 25 mm) of stretch in the spring. Clamp the cable to form a loop and cut off any excess, **see figure 41**.
6. Attach the cable to the insulator. For best results, make a double loop around the anti-roost insulator in the center groove of the insulator and fasten with a 1/16" cable clamp as shown in **Figure 41**.
7. Run the cable to the next insulator, attach a spring in the center groove at the anti-roost bracket and cut the cable at this point. The cable should be positioned in the insulator built into the top of each grill support along the feeder line.
8. Repeat this installation until the anti-roost cable is installed along the entire feeder line.
9. At the control unit, after clamping the cable to the spring, cut the cable about 8" to 10" (200 to 250 mm) longer than necessary. Feed the end of the cable through the center of the spring, around the first insulator on the control unit, and clamp the cable using the cable clamp supplied with the control unit. See **Figure 32**.
10. Install the wire form on the control unit insulators. Be sure the Guard snaps into the retainers molded into the insulators. See **Figure 32**.
11. Install the Poultry Trainer or Line Charger, as shown in **Figure 43** or **Figure 44**.



Key	Description
1	Cable Clamp
2	Clamp with Anti-Roost Bracket
3	Anti-Roost Cable
4	Spring should be stretched 3/4" to 1" (19 to 25 mm)

Figure 41. Anti-Roost Cable Installation

The Poultry Trainer is used to power all Anti-Roost lines in a house, see figure 43.

The Line Charger is used to power individual Anti-Roost lines in a house, see figure 44.

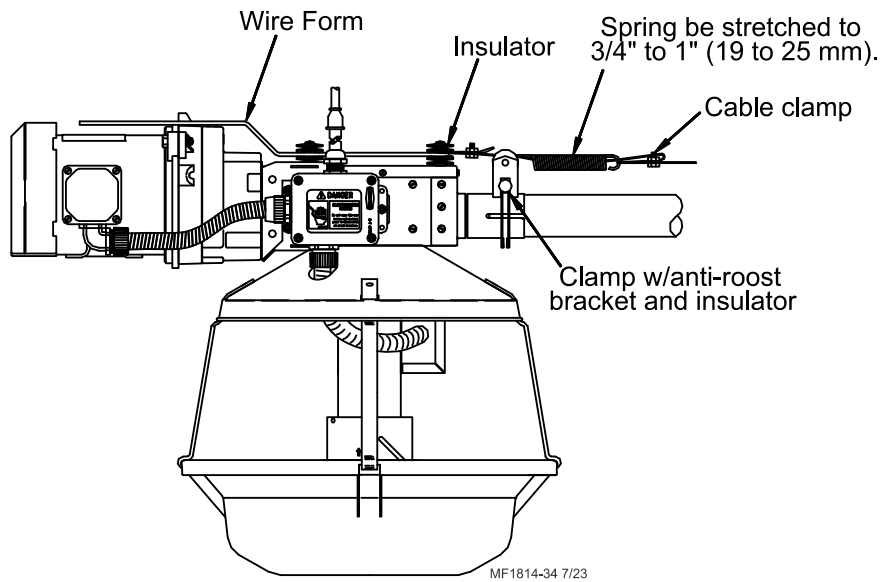

Figure 42. Anti-Roost Installation at Control Unit

Route the charger wire from the Poultry Trainer or Line Charger to the Anti-Roost system. Secure the Charger Wire to the Anti-Roost cable, using a cable clamp.

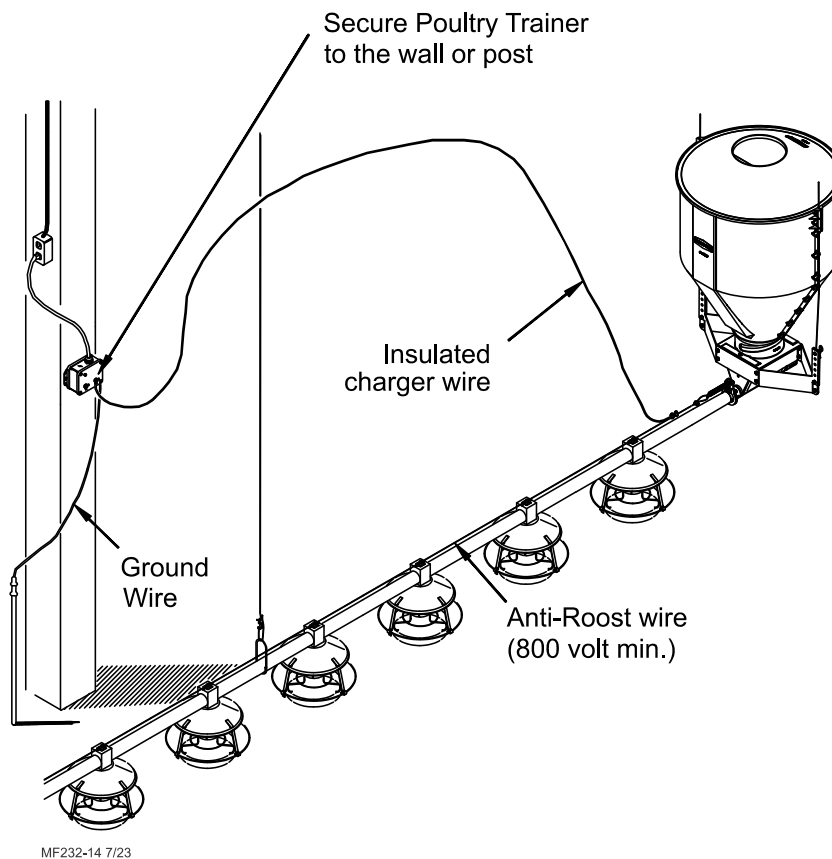

Figure 43. Poultry Trainer Installation

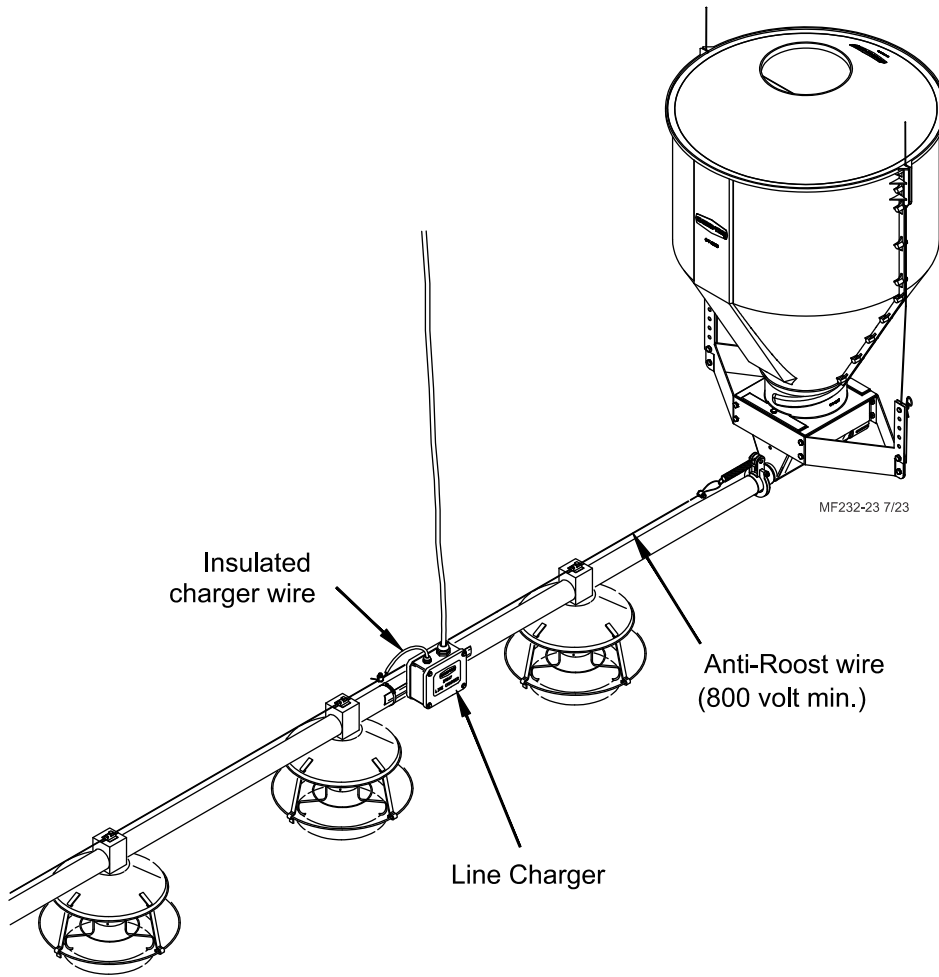

Figure 44. Line Charger Installation

12. The anti-roost system must be on a separate electrical circuit, allowing the system to be disconnected by a switch near the door.

Remember, the Anti-Roost System should be grounded through the poultry trainer.

Wiring Diagrams

Sensor Plus

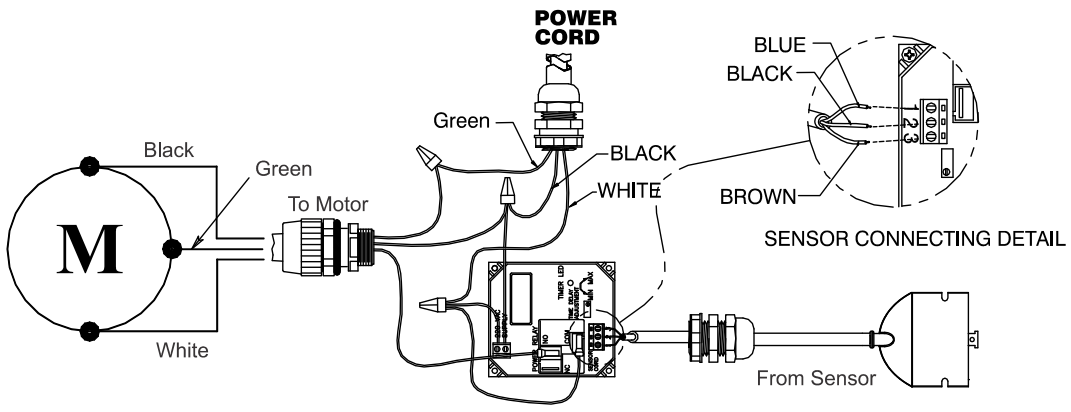

End & Intermediate Control Wiring Diagrams: Single Phase

Single Phase Wiring Diagram

FROM DISCONNECT OR CONTROL DISCONNECT
220/230 VOLTS 50/60 HZ.

SINGLE PHASE WIRING DIAGRAM

FEEDER LINE MOTOR
220/230 VOLTS 50/60 HZ.
SINGLE PHASE

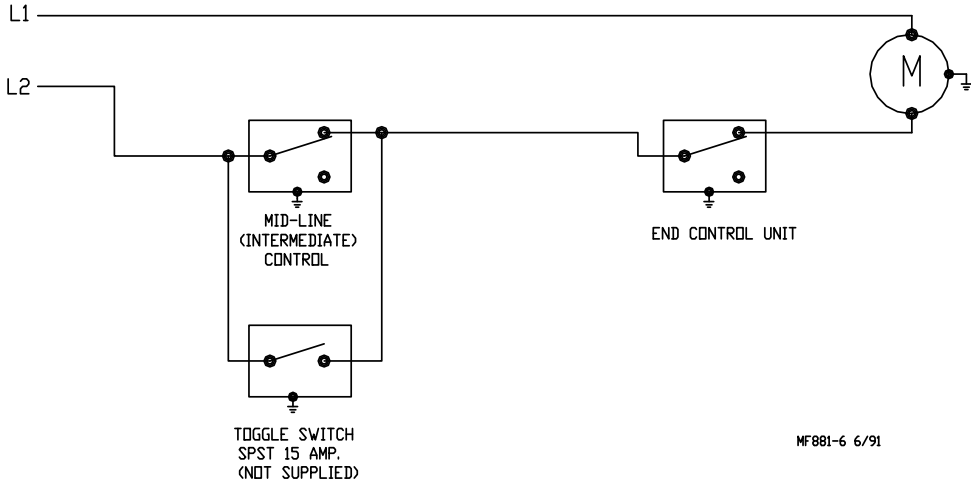

MF881-6 6/91

Single Phase Wiring Diagram

FROM DISCONNECT OR CONTROL DISCONNECT
220/230 VOLTS 50/60 HZ.

TO ADDITIONAL FEEDER LINES

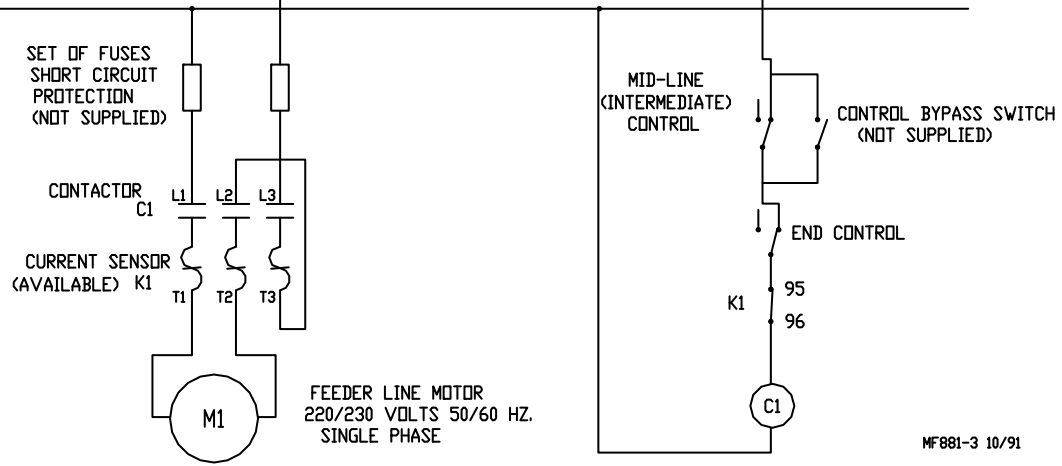

MF881-3 10/91

End & Intermediate Control Wiring Diagrams: Three Phase

Three Phase Wiring Diagram: 220/230V.

THREE PHASE WIRING DIAGRAM: 220/230 V

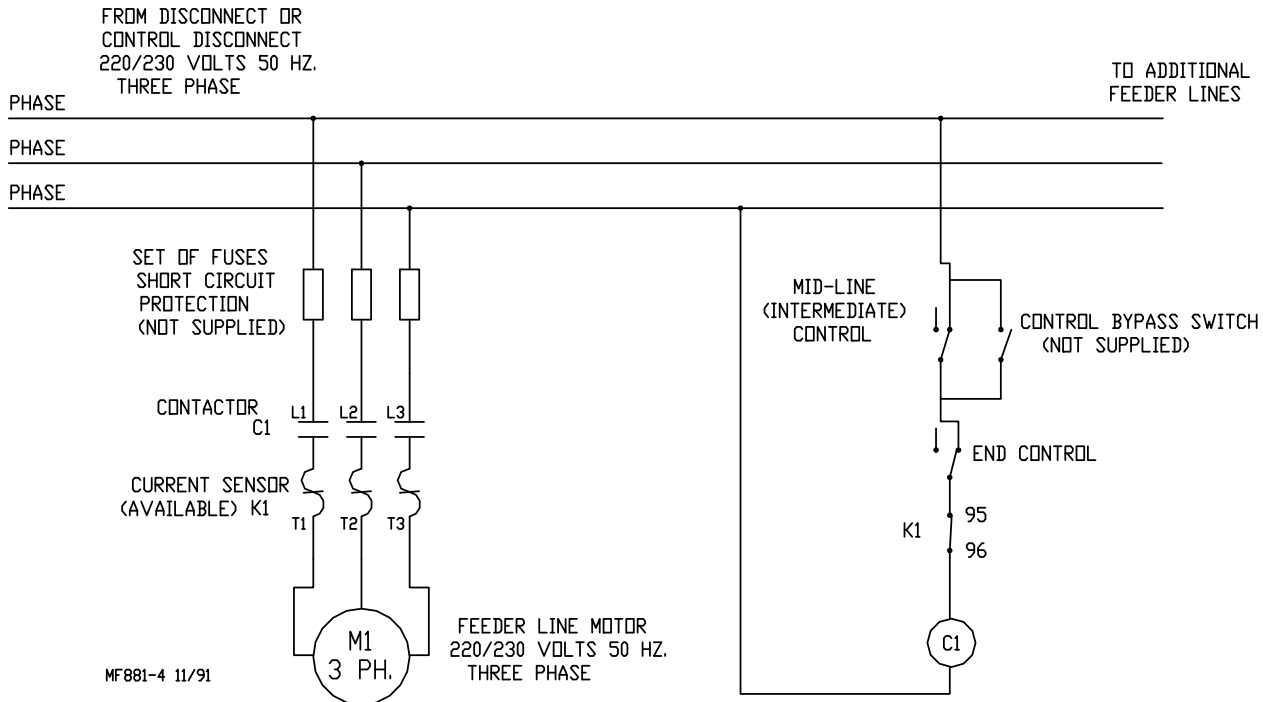

Three Phase Wiring Diagram: 380/415 V.

FROM DISCONNECT OR CONTROL DISCONNECT
380/415 VOLTS 50 HZ.
THREE PHASE

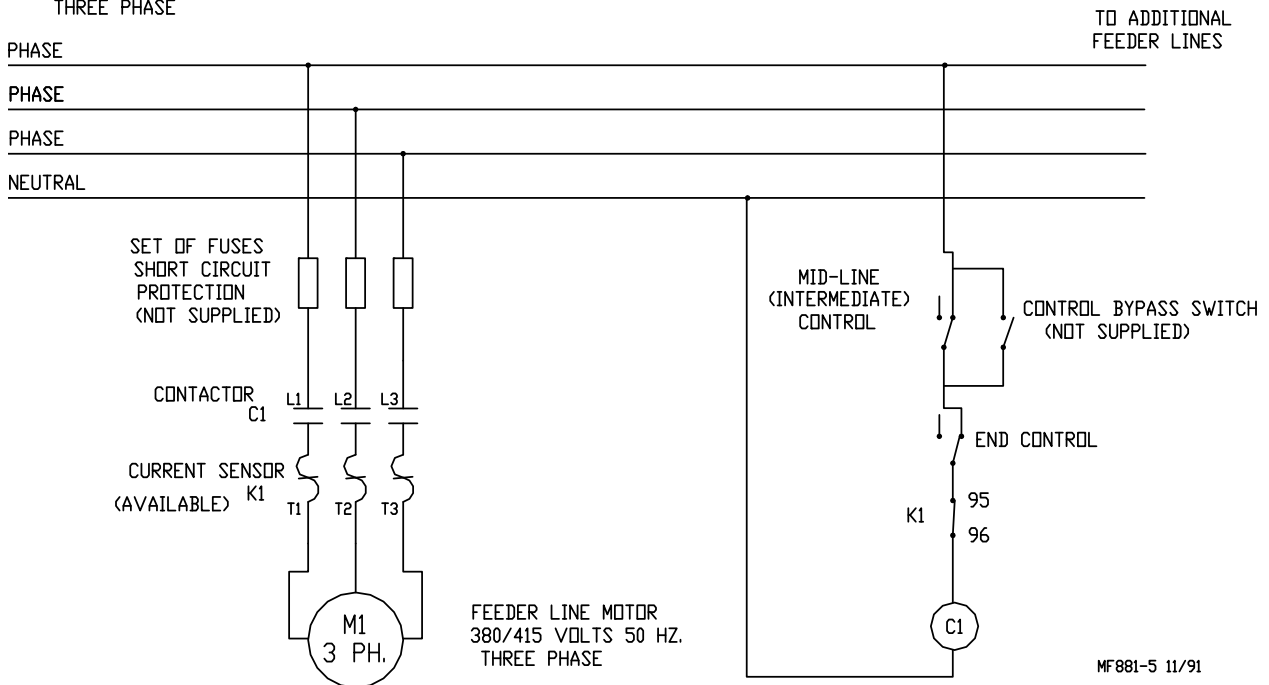

Parts Listings

200# Hopper Components

Item	Description	Part No.
1*	Hopper Cover (w/o hole)	28208
	Hopper Cover (w/ hole)	28702
2	Tube Support Assembly	14367
	Clamp	13948
	Chain	2128-1
3	Hopper Side (4 req'd)	2680
4	Boot Hanger	2671
5	Hanger Bracket Assembly	2681
6	Adjustment Bracket (2 req'd)	2706
7	Hair Pin	2664
8	Clevis Pin, 5/16 x 1"	2797-1

The 200# Hopper Assembly (w/o cover) may be ordered under Part No. 7941.

The 200# Hopper Assembly (w/cover) may be ordered under Part No. 28358.

*Both sides of the Hopper Cover and the required hardware may be ordered under Part No. 28206.

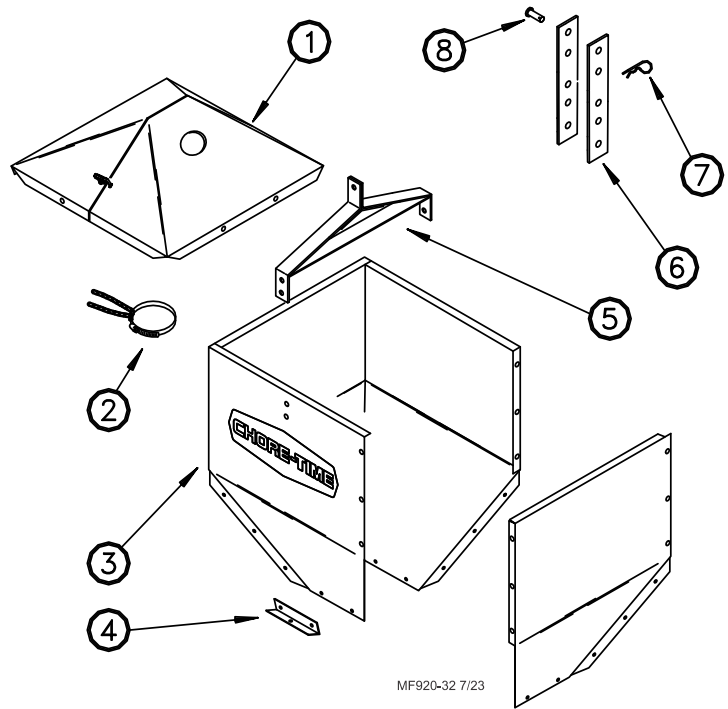

Feeder Line Components

Item	Description	Part No.
1*	Auger	6820-0
2	ATF Auger Tube (1-Hole Tube)	6684
	ATF Auger Tube (2-Hole Tube)	6685
	ATF Auger Tube (3-Hole Tube)	6686
3	Anti-Roost Bracket	29516
4	Clamp	29520
5	Line Charger	29317
6	Hanger	4207
7	Split Bolt	6342
8	Spring	7551
9	3/32" Cable	4973
10	Charger Wire (165 ft.)	28994-165
	Charger Wire (165 ft.)	28994-330
11	Poultry Trainer	29333
12	3/8" Hex Nut	1549
13	3/8" Flat Washer	4976

*Round up to the nearest 10'. Auger lengths from 50 to 500 feet. Example: 6820-200 would be a 200' roll of Auger.

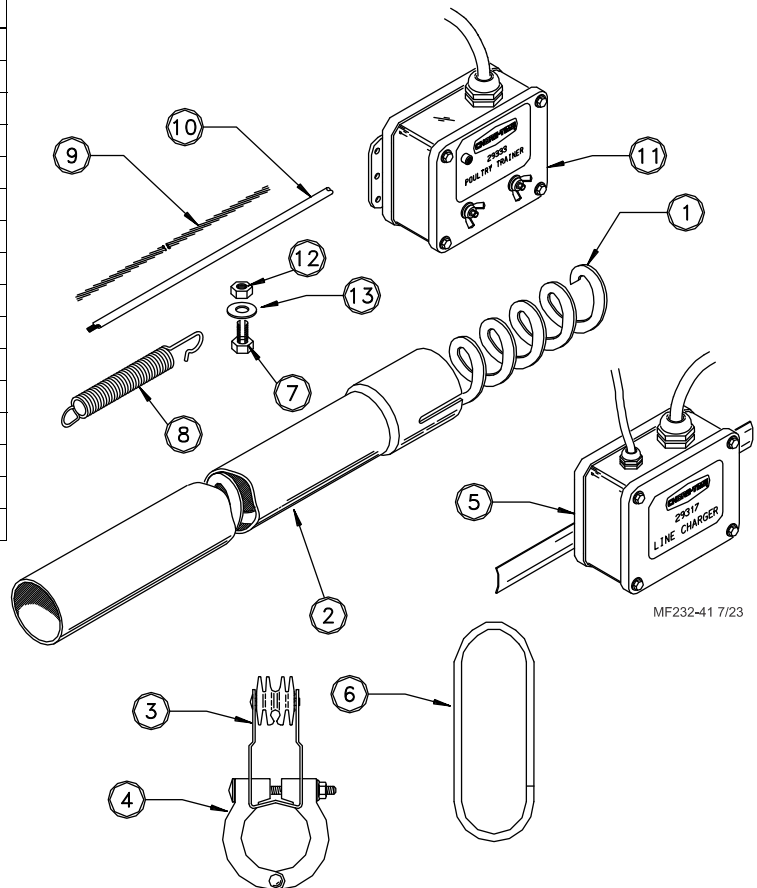

MODEL ATF™ PLUS Pan Components

MODEL ATF™ PLUS Pan Assembly
No Swing Down
Plastic Pan

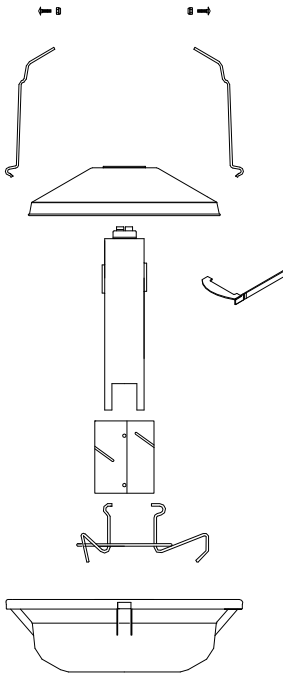

- 49141**
- (4) 22692 Carriage Bolt
 - (4) 8159 1/4-20 Lock Nut
 - (4) 49171 Pan Support
 - 49137 Pan Shield
 - (2) 44733U Shield Support
 - 49136 Drop Tube
 - 4194 Feed Tube
 - *29320 Feed Ring
 - 29000 Turkey Pan

*Feed Ring 42773 May be used in place of 29320

MODEL ATF™ PLUS Pan Assembly
With Swing Down
Plastic Pan

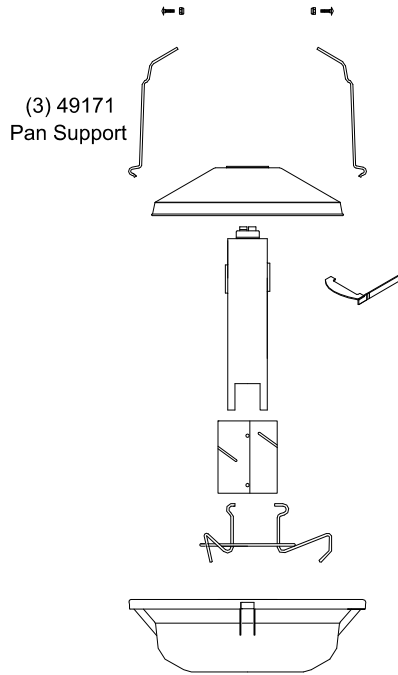

- 49175**
- (4) 22692 Carriage Bolt
 - (4) 8159 1/4-20 Lock Nut
 - (1) 49172 Pan Support Swinging
 - 49137 Pan Shield
 - (2) 44733U Shield Support
 - 49136 Drop Tube
 - 4194 Feed Tube
 - *29320 Feed Ring
 - 29000 Turkey Pan

*Feed Ring 42773 May be used in place of 29320

MODEL ATF™ PLUS Pan Assembly
No Swing Down
Metal Pan

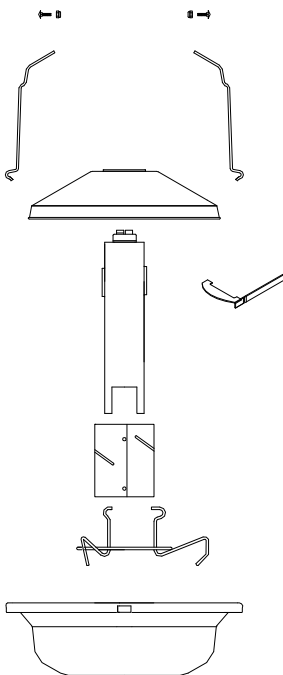

- 49177**
- (4) 22692 Carriage Bolt
 - (4) 8159 1/4-20 Lock Nut
 - (4) 49171 Pan Support
 - 49137 Pan Shield
 - (2) 44733U Shield Support
 - 49136 Drop Tube
 - 4194 Feed Tube
 - *29320 Feed Ring
 - 4193 Turkey Pan Steel

*Feed Ring 42773 May be used in place of 29320

MODEL ATF™ PLUS Pan Assembly
With Swing Down
Metal Pan

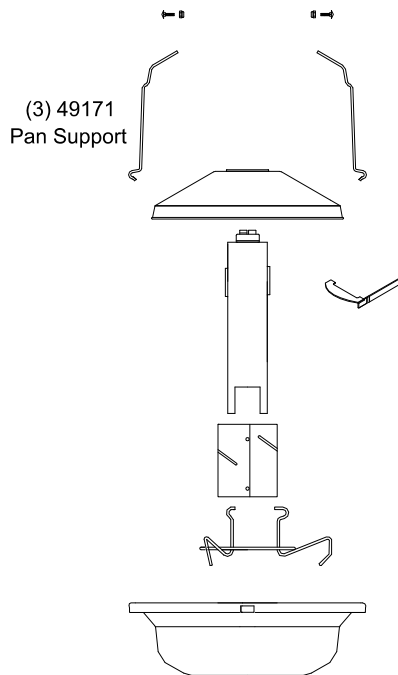

- 49176**
- (4) 22692 Carriage Bolt
 - (4) 8159 1/4-20 Lock Nut
 - (1) 49172 Pan Support Swinging
 - 49137 Pan Shield
 - (2) 44733U Shield Support
 - 49136 Drop Tube
 - 4194 Feed Tube
 - *29320 Feed Ring
 - 4193 Turkey Pan Steel

*Feed Ring 42773 May be used in place of 29320

MF1814-23 6/04

Optional Parts

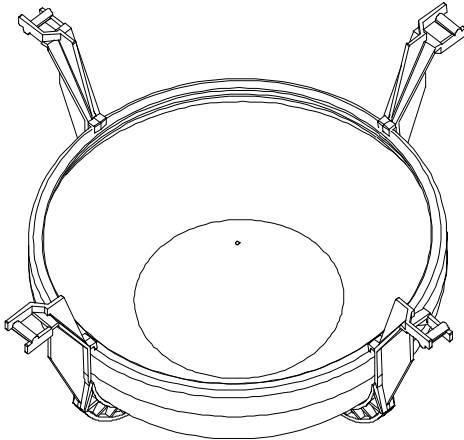

THE H2 PLUS PAN ADAPTER IS MADE UP OF TWO PARTS PLUS H2 PAN

PART NO. 41474 INCLUDES 41100-1 & -2
 TOP HALF PART NO. 41100-1
 BOTTOM HALF PART NO. 41100-2
 H2 PLUS PAN PART NO. 24901
 PART NO. 41475 INCLUDES 41100-1 & -2
 PLUS 24901 PAN

FEED RING PART NO. 42773

APPLICATION: THIS PRODUCT WILL BE USED WHERE THE DAY OLD TURKEYS WILL BE STARTED ON THE ADULT TURKEY FEEDER FOR THE FIRST 5 WEEKS. THEN THE PAN ASSEMBLY WILL BE REMOVED AN THE ADULT PAN INSTALLED.

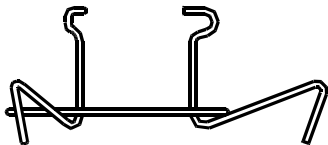

Use 42773 Feed level ring with the H2 Plus Adapter

New Shield Support replaces 6443

(2) 44733 Shield Support

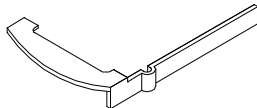

Power Unit Components

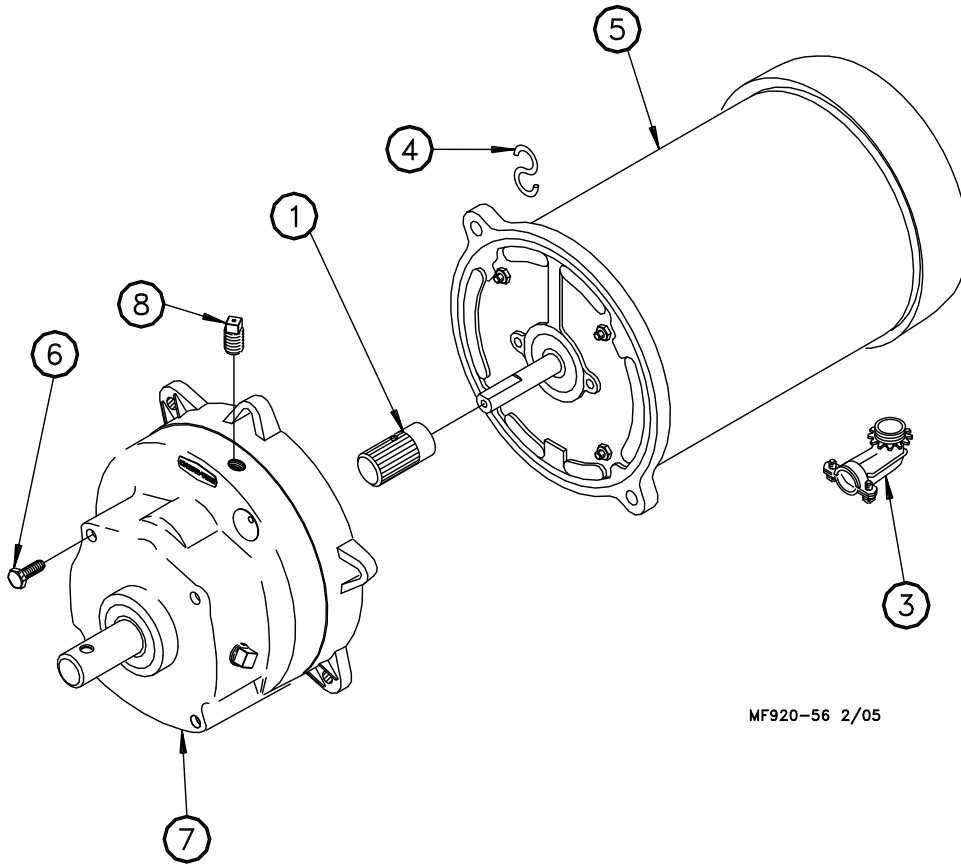

MF920-56 2/05

Item	Description	3259-34 Part No.	3259-39 Part No.	3259-98 Part No.	3259-100 Part No.
1	Pinion Assembly	5046	5046	5046	5046
2	Cord Assembly	--	--	28028	--
3	Connector (90 degree)	4228	4228	4228	--
4	Motor	4229	5703	5977	28031
5	5/16-18x5/8 Hex Hd Screw	4412-1	4412-1	4412-1	4412-1
6	Gearhead	3261-5	3261-5	3261-11	3261-11
7	Pipe Plug	3516	3516	3516	3516
8	"S" Hook	4270	4270	4270	4270

Power Unit Assembly Part Numbers:

Part No.	HP	RPM	Phase	Hz	Voltage	Usages
3259-34	1/3 HP	348 RPM	Single Phase	60 Hz	230	Use with both Control Units
3259-39	1/2 HP	348 RPM	Single Phase	60 Hz	230	Use with both Control Units
3259-98	1/2 HP	348 RPM	Single Phase	50 Hz	230	Use with both Control Units
3259-100	1/2 HP	348 RPM	Three Phase	50 Hz	220/380	Use with both Control Units

MODEL ATF™ PLUS Control Unit Components (Sensor Plus) Part # 49148

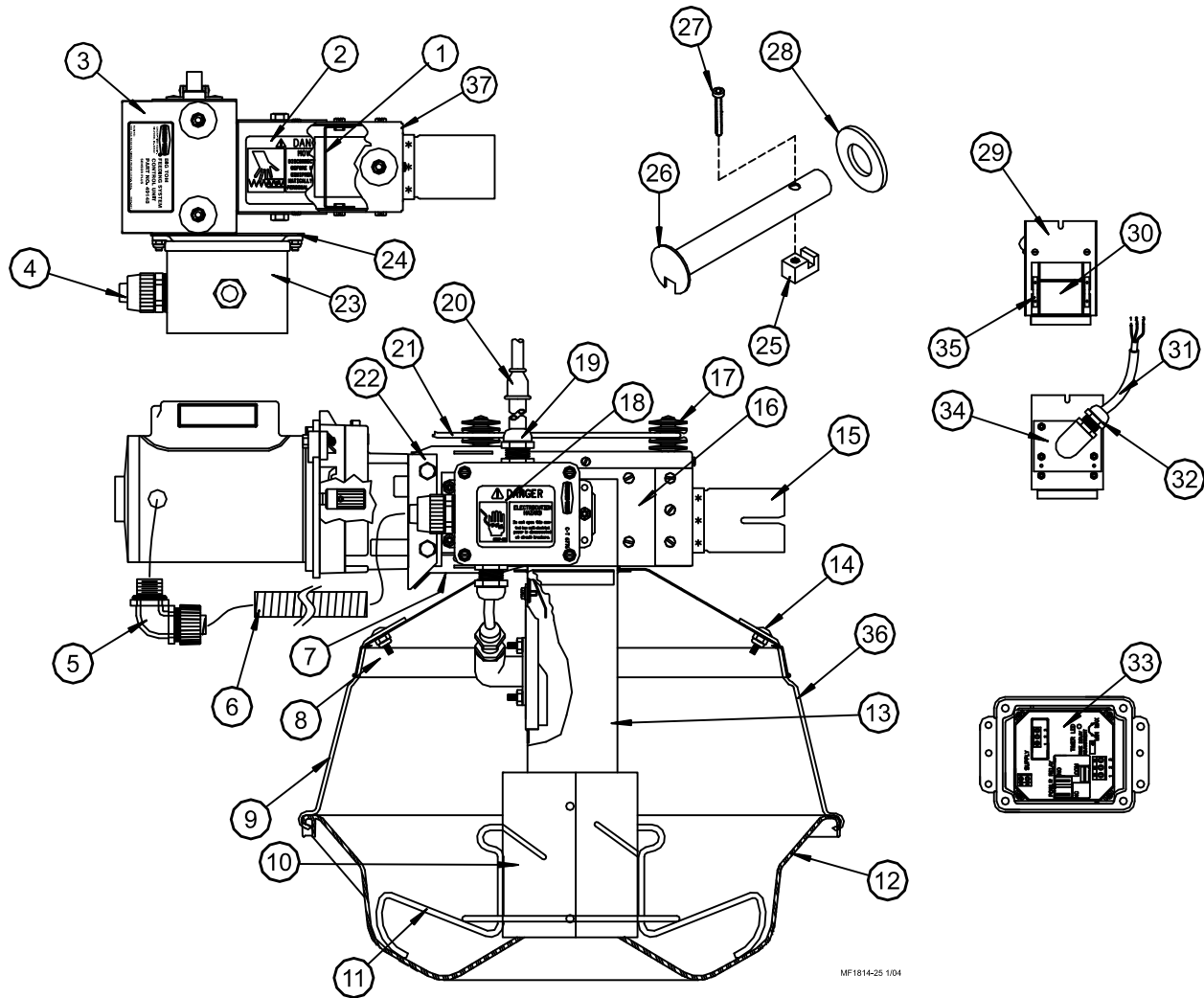

MF1814-25 1/04

Item	Description	Part No.	Item	Description	Part No.
**1	Tube Support	27891	19	1/2" Water Tight Connector	24685
**2	Danger Decal	2527-9	20	Cord Assembly	4999-100
3	Cover Insulator Assembly	49043	21	Anti-Roost Guard	2798
4	1/2" Conduit Connector	26980	22	Anchor Plate	4188
5	90°, 1/2" Connector	23810	23	Junction Box	42627-8
6	1/2" Flex Conduit	26982-1	24	Mount Plate	43815
7	Bottom Cover	49044	25	Drive Block	4642
8	Pan Shield	49138	26	Tube Weldment	47584
9	Pan Support	49171	27	SKTH CP 255-20x1.50 Screw	5083-8
10	Feed Level Tube Assembly	4341	28	Washer	1484
	Feed Level Tube Assembly	4194	29	Adapter Plate	43813
11	Feed Level Ring	29320	30	Level Sensor	46162
12	Turkey Plastic Feeder Pan	29000	31	Black Tubing	14454-10
	Turkey Steel Feeder Pan	4193	32	1/2" Water Tight Connector	23779
13	Drop Tube Assembly	49147	33	Circuit Board	46161
14	1/4-20x.625 Carriage Bolt	22692	34	Plastic Adapter Plate	43819
**15	Stub Tube Weldment	27900	35	Sensor Retainer	46314
**16	Control Body	49042	36	Pan Support Swing Down	49172
**17	Insulator	2976	**37	Body Cover	27942
18	Danger Decal	2527-35			

**These components may be ordered as an assembly Part No. 49045.

MODEL ATF™ PLUS Control Unit Components: Part No. 49146

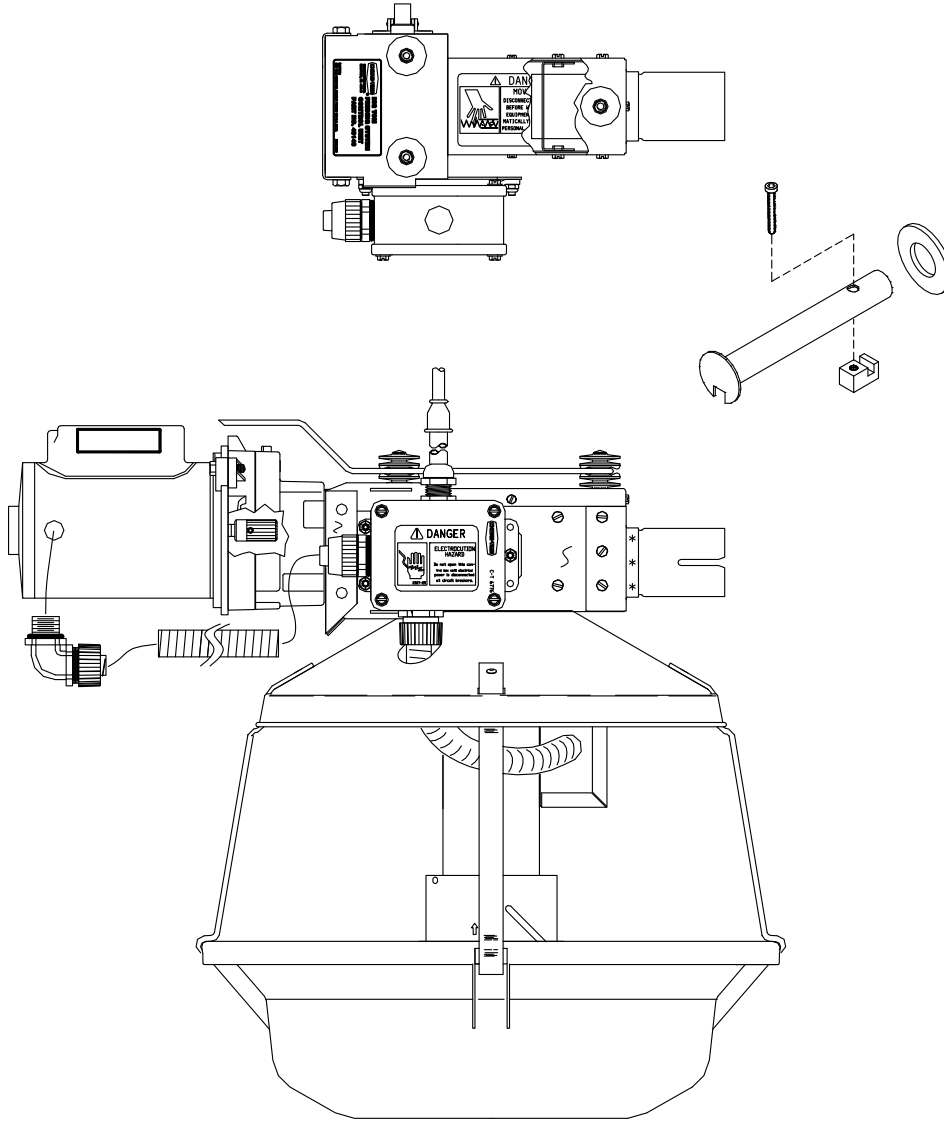

Item	Description	Part No.	Item	Description	Part No.
1	Cover, Insulator Assembly	49043	12	Drop Tube Assembly	49147
**2	Danger Decal	2527-9	13	Pan Support	49171
**3	Tube Support	27891	*14	Conduit Assembly	27866
**4	Body Cover	27942	15	Bottom Cover	49044
5	Mount Plate	43815	16	Junction Box	36344-5
**6	Insulator	2976	17	Danger Decal	2527-35
**7	Stub Tube Weldment	27900	18	Anchor Plate	4188
**8	Control Body	49042	19	Anti-Roost Guard	2798
9	Swing Down Pan Support	49172	20	1/2" Flex Conduit	26982-1
10	Turkey Plastic Feeder Pan	29000	21	90°, 1/2" Connector	23810
	Turkey Steel Feeder Pan	4193	22	Drive Block	4642
11	Feed Level Tube Assembly	4341	23	Tube Weldment	47584
	Feed Level Tube Assembly	4194	24	SKTH CP 255-20x1.50 Screw	5083-8
			25	Washer	1484

*See part no. 49147 on page 41 for assembly parts.

**These components may be ordered as an assembly Part No. 49045.

Drop Tube Assembly: Part No. 49147

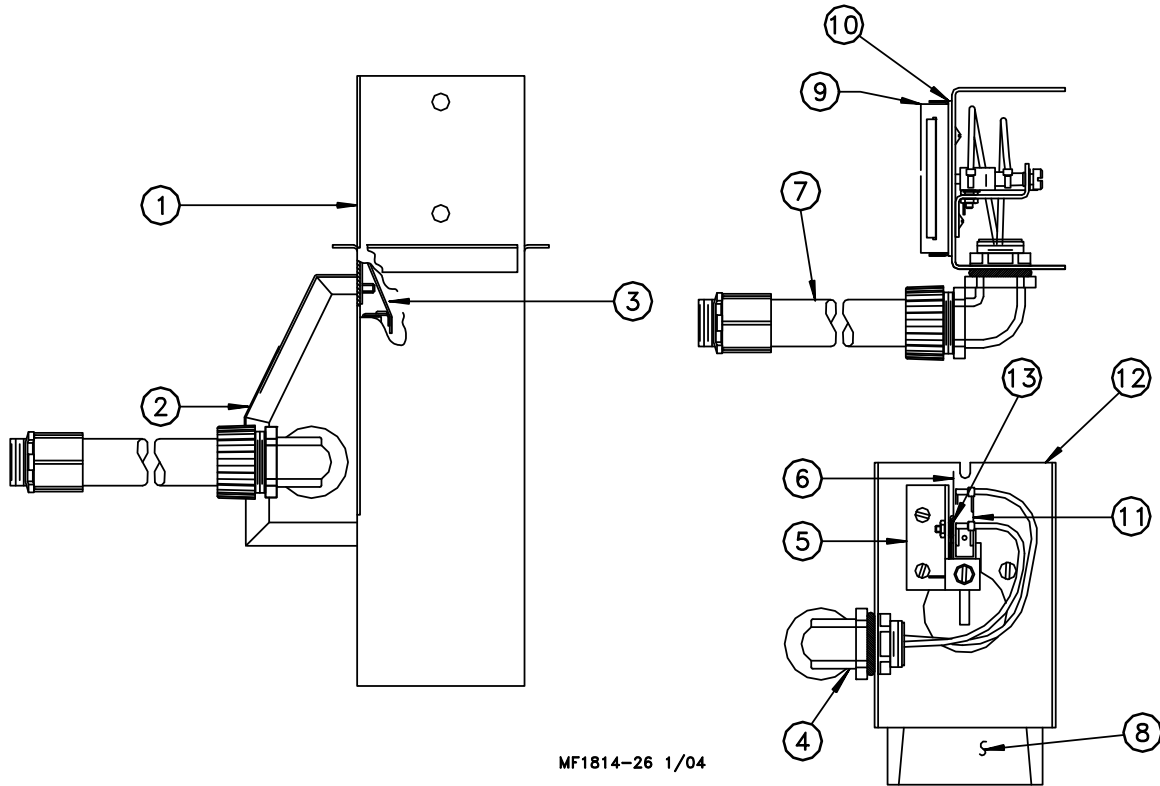

Item	Description	Part No.
1	Control Drop Tube Weldment	49145
2	Cover	6053
3	Guard Assembly	4892
4	90° Conduit Connector	24726
5	Switch Bracket Assembly	6045
6	Barrier	6936
7	Conduit Assembly	27866
8	Paddle	4890
9	Diaphragm Assembly	4889
10	Spacer Plate	4921
11	Snap Action Switch	46324
12	Housing	6048
13	Torsion Spring	5820

Single Boot Components: Part No. 6821

Item	Description	Part No.
1	Boot Weldment	4224
2	Tube Clamp	24062
3	Outlet Tube	4556
4	Sleeve	5648
5	3/16 x 1" Pin	2960-1
6	Bearing	2689
7	Washer	2955-14
8	Anchor	38540
9	5/16-18 x 7/8 low head cap screw	47867
10	Anchor and Bearing Ass'y	39372
11	Cannonball	3531
12	Cotter Pin	1639
13	Chain	2128-1
14	Latch Pin Ass'y	2683
15	Cap	29373
16	Flat Washer	2955-58
17	Roll Pins	2960-1
--	Danger Decal	2527-9

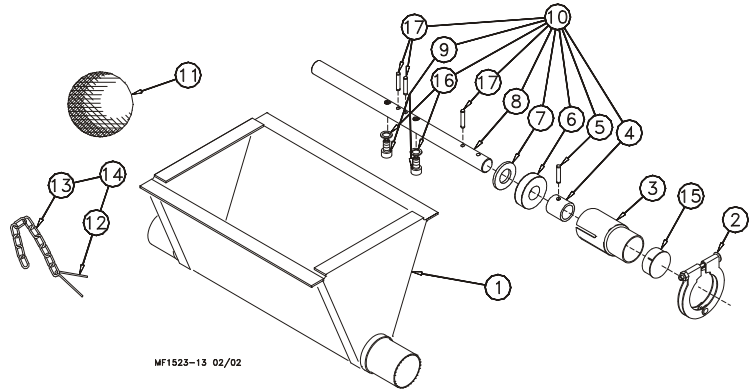

Twin Boot Components: Part No. 8460

Item	Description	Part No.
1	Boot Weldment	8461
2	Tube Clamp	29520
3	Cap	29523
4	Stub Tube	4163
5	Sleeve	5648
6	3/16 x 1" Pin	2960-1
7	Bearing	29433
8	Washer	2955-14
9	Bearing Retainer	29441
10	Anchor	29526
11	Set Screw	1174
12	Anchor and Bearing Ass'y	29530
13	Cotter Pin	1639
14	Chain	2128-1
15	Latch Pin Ass'y	2683
16	Cannonball	3531
--	Danger Decal	2527-9

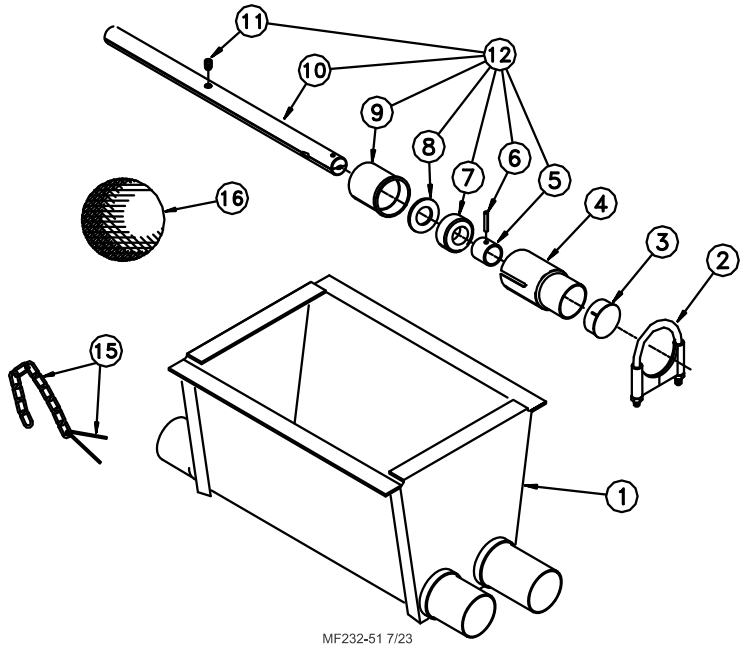

Winch (Part No. 47687)

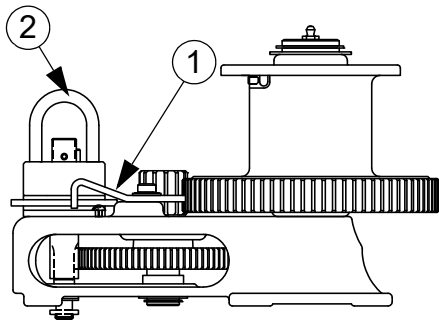

Item	Qty.	Description	Part No.
1	1	Pawl	47687-5
2	1	Input Shaft Assembly	47687-1

Feed Level Tube Winch Kit: Part No. 46218

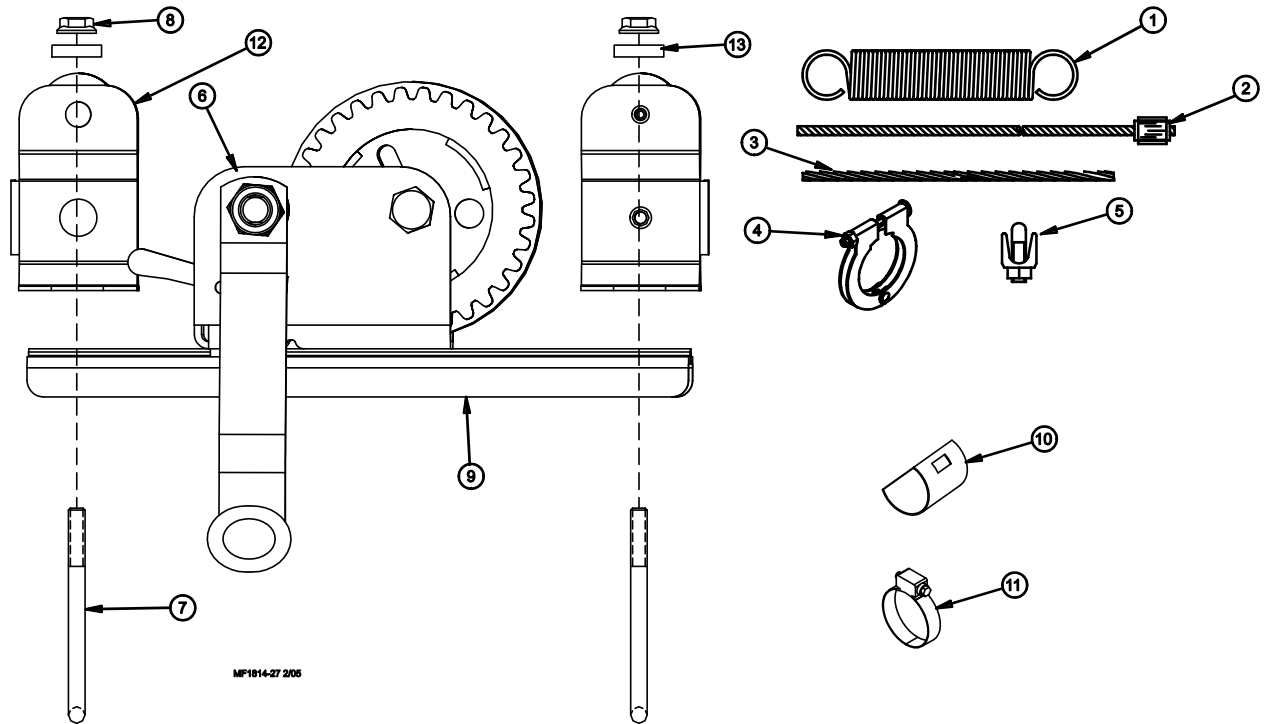

Item	Description	Part No.
1	Spring .62 x 11"	24302
2	Cable Assembly	14278
3	3/32" 7 x 19 Galv. Cable	28394
4	2" Tube Clamp	29520
5	1/8" Cable Clamp	14898
6	Feed Level Tube Winch	43391
7	1/4" x 20 U Bolt	7975
8	1/4" x 20 Flange Nut	46298
9	Winch Base Assembly	48933
*10	Tube Closure	9126
*11	Adjustment Clamp	3527
12	Insulator Bracket	49230

These parts may be ordered as a kit under Part No. 14585.

Miscellaneous Suspension Components

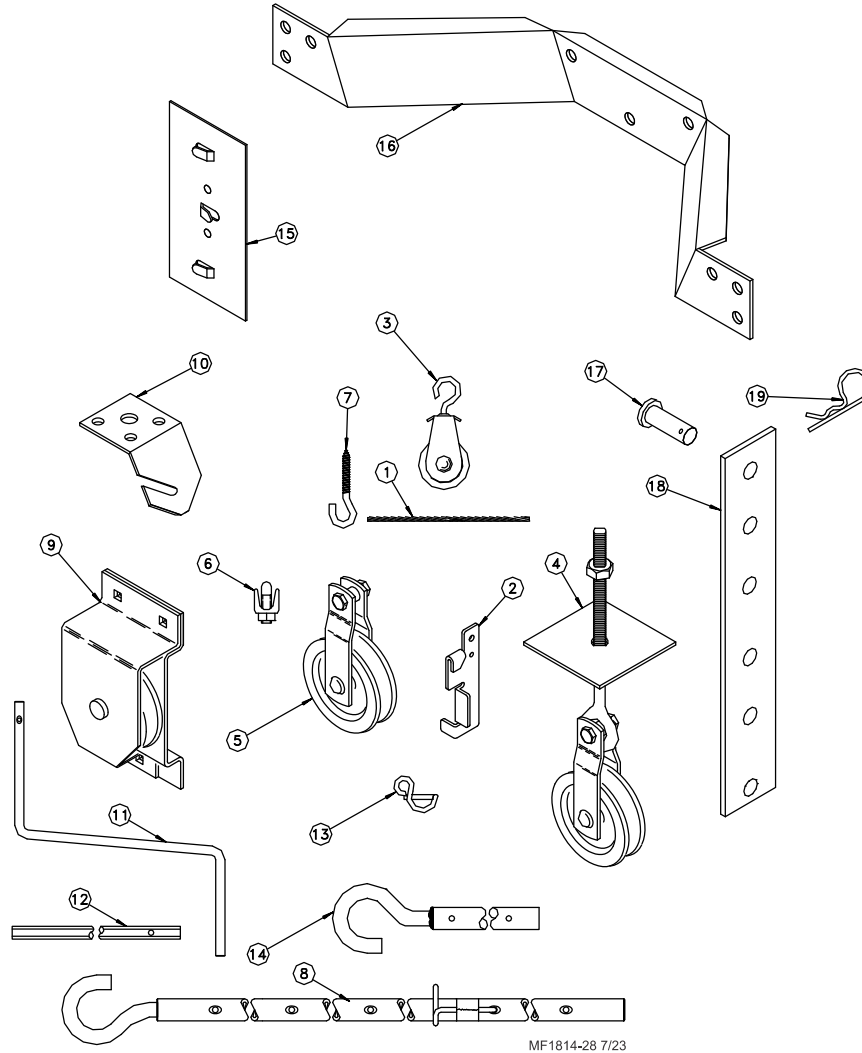

MF1814-28 7/23

Item	Description	Part No.	Item	Description	Part No.
1	3/16" Cable	1213	13	Winch Handle Pin	3761
2	Cable Lock	14337	14	Winch Drive Tube (4')	2884-1
3	Pulley with Swivel	3004		Winch Drive Tube (8')	2884-2
4	Heavy Duty Pulley Assembly	2014		Winch Drive Tube (2')	2884-4
5	Pulley	2500	--	Full Line Suspension Kit	7948
6	3/16" Cable Clamp	732	15	Cable Guide	34573
7	ATF Screw Hook	2041	16	Hopper Mount (Single Boot)	34589
8	Extendable Drive Tube	47637		Hopper Mount (Twin Boot)	38242
9	Pulley Assembly	28429	17	Clevis Pin, 5/16" x 1"	2797-1
10	Ceiling Hook	28550	18	Adjustable Bracket	2706
11	Handle Shank	3148	19	Hair Pin	2664
12	Drill Adapter Shaft	2886			

Item 11 and 13 may be ordered as a kit under Part No. 2885.
 Item 12 and 13 may be ordered as a kit under Part No. 2886.
 Item 11, 13 and 8 may be ordered as a kit under Part No. 47683.

Maintaining the MODEL ATF™ PLUS Feeding System

The MODEL ATF™ PLUS require minimum maintenance. However, a routine periodic inspection of the equipment will prevent unnecessary problems.

Maintenance should be done by a qualified technician.



ALWAYS DISCONNECT POWER TO THE SYSTEM WHEN SERVICING OR MAINTAINING THE EQUIPMENT. FAILURE TO DISCONNECT POWER MAY CAUSE INJURY OR DEATH.

1. Check the oil level in the gear heads at installation and every 6 months. The Pipe Plug, on the side of the gear head, indicates proper oil level. Add SAE 40W oil when necessary.

The oil in the gear heads should be replaced every 12 months with new SAE 40W oil.

- A. Remove the bottom Pipe Plug to drain the oil. Discard used oil in accordance with local and national codes.
- B. Wipe any debris off the magnet on the bottom Pipe Plug and reinstall. Remove the side Pipe Plug and (top) Vent Plug.
- C. Set the power unit in the horizontal position.
- D. 2-Stage Gearheads: Add approximately 9 oz. (266 ml) of SAE 40W oil through top hole. This should be just enough oil to reach the side Pipe Plug.

3-Stage Gearheads (3261-9, 3261-12, 3261-14): Add approximately 13 oz. (384 ml) of SAE 40W oil through top hole. This should be just enough oil to reach the side Pipe Plug.

- E. Install the side Pipe Plug and (top) Vent Plug.
2. Check equipment for loose hardware every 6 months--including the Anchor Block. Tighten if necessary.
 3. Switch Adjustment procedure for the Control Units:.

- A. Turn the adjustment nut counter-clockwise until the switch clicks.
- B. Turn the adjustment nut clockwise until the switch clicks.
- C. Turn the adjustment nut counter-clockwise 3/4 turn.

4. Keep anti-roost cables tightly stretched. This increases the effectiveness of the electro-guard anti-roost system and keep the pans from being tilted when birds push against them.

5. Remove all feed from the feeder when there are no birds in the house and when the building is washed and disinfected.

Turn the feeders off prior to removing the birds from the house. This will allow them to clean the feed out of the pans.

6. If the system is not to be used for an extended period of time, remove all the feed from the feeder lines and feeder pans.

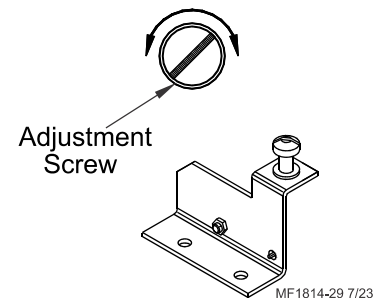

Figure 45. Switch Adjustment

7. If the system must be disassembled, extreme caution must be used to prevent injury from springing auger.

A. Disconnect power to the entire system.

B. Pull the Anchor and Bearing Assembly and approximately 18" (45 cm) of auger out of the boot.

C. Place a clamp or locking pliers on the auger to prevent it from springing back into the auger tubes.

D. Remove the Anchor & Bearing Assembly.

E. Carefully remove the locking pliers.

CAUTION: Stand clear...the auger may spring back into the tubes.

F. Remove system components in the opposite order they were installed, according to this manual.

8. Grease the winch every 6 months with 1 to 2 shots of common industrial or automotive grease. **DO NOT OVER GREASE THE WINCH.**

9. Remove any feed build-up in the Safety Switch Boxes in the Control Units.

10. It may be necessary to periodically retighten the shocker cable. Be sure to disconnect power to the shocker before servicing the equipment.

SENSOR PLUS Sensor Switch Adjustment for Control Units

The SENSOR PLUS Pan Half Round Sensor Switch is adjusted at the factory to a sensitivity of .125" from the face of the sensor and a time delay of 15 seconds, the time delay adjustment is 0 seconds to 600 seconds.

To adjust the Time Delay (see figure 1.):

- For less time — turn Time Delay Adjusting Screw (item 5) counter-clockwise (Light (item 6) blinks fast)
- For more time — turn Time Delay Adjusting Screw (item 5) clockwise (Light (item 6) blinks slow)

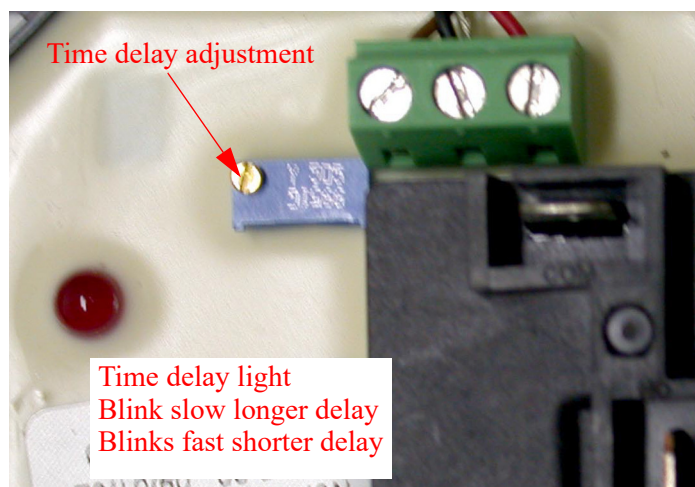
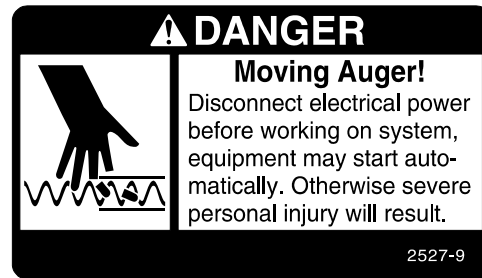
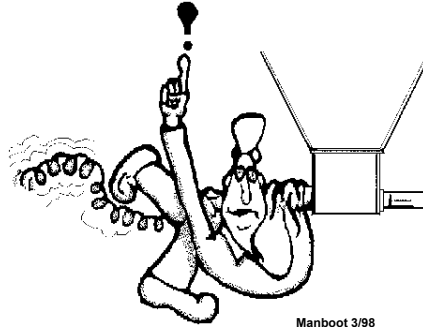

Figure 1. Adjusting Sensor Plus Proximity Switch



BE CAREFUL WHEN WORKING WITH AUGER!



Trouble Shooting the MODEL ATF™ PLUS Feeding System

ALWAYS DISCONNECT POWER TO THE SYSTEM WHEN SERVICING OR MAINTAINING THE EQUIPMENT. FAILURE TO DISCONNECT POWER MAY CAUSE INJURY OR DEATH.

Service and maintenance work should be done by a qualified technician only.

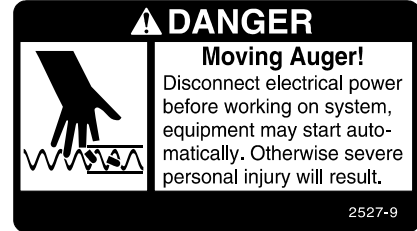
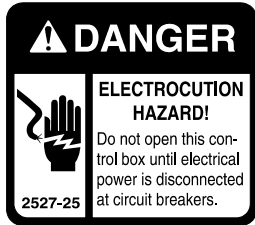

Problem	Possible Cause	Corrective Action
None of the feeder lines will operate.	No power supplied to equipment.	Replace burned fuses or reset circuit breaker. Make sure voltage required is supplied.
	Time clock or relay defective.	Replace time clock or relay.
	Time clock improperly programmed.	Refer to programming the time clock section and reprogram the time clock.
Feeder line will not operate.	Power unit cord not plugged in sufficiently to make contact.	Check motor cord plug at control unit and control unit plug at outlet for connection.
	Motor cord wires are broken at plug or where cord enters motor.	Check cord for continuity, replace if defective.
	Power units thermal overload tripped.	Push motor overload reset button to reset.
	Control unit switch defective or out of adjustment.	Adjust switch according to the switch adjustment procedure in the maintenance section.
Motor overloads frequently.	Oil on new auger loads motor excessively when feed is carried for first time.	Polish auger by running 50 lb. (20 kg) increments of feed out to pans.
	Inadequate power reaching motors.	Check line voltage at the motors. Wiring of adequate size is essential to feeder operation.
	Object caught in the auger; motor runs, stalls, then auger spins in reverse.	Check hopper boot, control unit and pan outlets. Remove obstruction.
Auger runs erratically.	Frozen or cracked bearing at boot anchor.	Replace bearing. Slowly ease auger back into tube. Be careful no to damage the bearing when reinserting the auger.
	Insufficient stretch in auger.	Shorten the auger.
	Obstruction in auger.	Remove obstruction.
Auger tube or boot wears out rapidly (Noisy feeder operation)	Auger is bent or kinked	Repair or replace damaged auger.
	End of auger is riding up on anchor weldment.	Auger must not be positioned over weld on anchor. Check for bent or damaged auger.
Oil leaking out of seals on power unit	Gearhead vent plug not installed.	Replace plastic shipping plug with vent plug.
	Defective gear head seal.	Replace seal.
Not enough feed supplied to the feeder pans.	Insufficient time programmed on the time clock.	Add more operating time to feeding period.
	Feeder line control unit switch out of adjustment.	Adjust switch according to the switch Adjustment procedure in the maintenance section.



**MADE TO WORK.
BUILT TO LAST.®**

Revisions to this Manual

Page No.	Description of Change	ECO
42	Was 2883 Winch	35577
Various	Updated graphics	

**For additional parts and information, contact your nearest Chore-Time distributor or representative.
Find your nearest distributor at: www.choretime.com/contacts**

CTB, Inc.
PO Box 2000
Milford, Indiana 46542-2000 USA
Phone (574) 658-4101
Email: choretime@choretime.com
Internet: www.choretime.com