

Model H2™ PLUS Feeding Systems

Installation & Operator's Instruction Manual

Installation and Operators Manual

Installation and Operators Manual

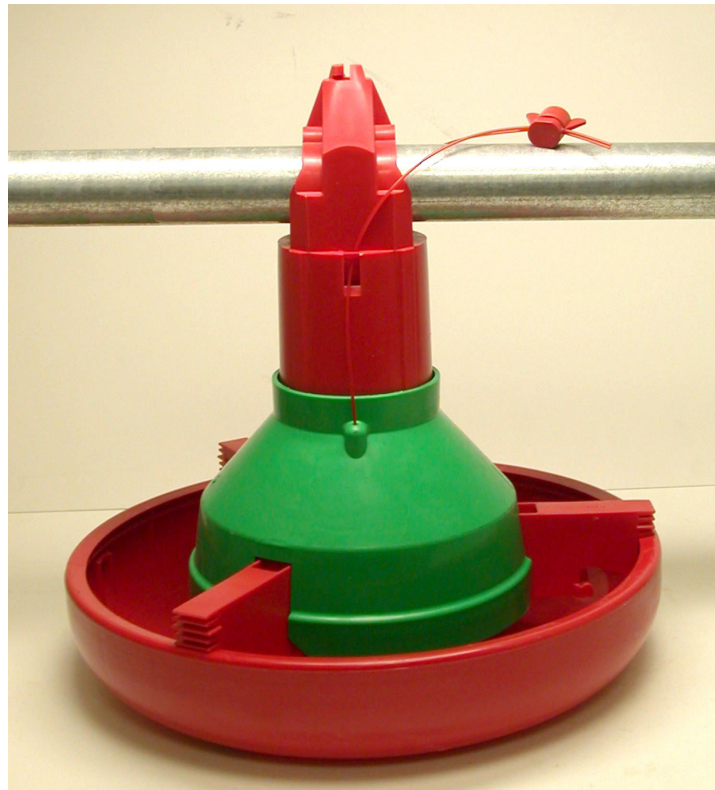

Chore-Time Warranty

LIMITED WARRANTY

CTB, Inc. (“Chore-Time”) warrants each new CHORE-TIME Product manufactured by Chore-Time to be free from defects in material or workmanship under normal usage and conditions, for One (1) year from the date of installation by the original purchaser (“Warranty”). Chore-Time provides for an extension of the aforementioned Warranty period (“Extended Warranty Period”) with respect to certain Product parts. If such a defect is determined by Chore-Time to exist within the applicable period, Chore-Time will, at its option, (a) repair the Product or Component Part free of charge, F.O.B. the factory of manufacture or (b) replace the Product or Component Part free of charge, F.O.B. the factory of manufacture. This Warranty is not transferable, and applies only to the original purchaser of the Product.

CONDITIONS AND LIMITATIONS

THIS WARRANTY CONSTITUTES CHORE-TIME’S ENTIRE AND SOLE WARRANTY AND CHORE-TIME EXPRESSLY DISCLAIMS ANY AND ALL OTHER WARRANTIES, INCLUDING, BUT NOT LIMITED TO, EXPRESS AND IMPLIED WARRANTIES, INCLUDING, WITHOUT LIMITATION, WARRANTIES AS TO MERCHANTABILITY OR FITNESS FOR PARTICULAR PURPOSES. CHORE-TIME shall not be liable for any direct, indirect, incidental, consequential or special damages which any purchaser may suffer or claim to suffer as a result of any defect in the Product. Consequential or Special Damages as used herein include, but are not limited to, lost or damaged products or goods, costs of transportation, lost sales, lost orders, lost income, increased overhead, labor and incidental costs, and operational inefficiencies. *Some jurisdictions prohibit limitations on implied warranties and/or the exclusion or limitation of such damages, so these limitations and exclusions may not apply to you. This warranty gives the original purchaser specific legal rights. You may also have other rights based upon your specific jurisdiction.*

Compliance with federal, state and local rules which apply to the location, installation and use of the Product are the responsibility of the original purchaser, and CHORE-TIME shall not be liable for any damages which may result from non-compliance with such rules.

The following circumstances shall render this Warranty void:

- Modifications made to the Product not specifically delineated in the Product manual.
- Product not installed and/or operated in accordance with the instructions published by the CHORE-TIME.
- All components of the Product are not original equipment supplied by CHORE-TIME.
- Product was not purchased from and/or installed by a CHORE-TIME authorized distributor or certified representative.
- Product experienced malfunction or failure resulting from misuse, abuse, mismanagement, negligence, alteration, accident, or lack of proper maintenance, or from lightning strikes, electrical power surges or interruption of electricity.
- Product experienced corrosion, material deterioration and/or equipment malfunction caused by or consistent with the application of chemicals, minerals, sediments or other foreign elements.
- Product was used for any purpose other than for the care of poultry and livestock.
-

The Warranty and Extended Warranty may only be modified in writing by an officer of CHORE-TIME. CHORE-TIME shall have no obligation or responsibility for any representations or warranties made by or on behalf of any distributor, dealer, agent or certified representative.

Effective: **April 2014**

Table of Contents

Topic	Page
About this Manual	5
Safety Information	5 - 6
Safety–Alert Symbol.	5
Signal Words.	5
DANGER: Moving Auger	6
DANGER: Electrical Hazard	6
CAUTION:	6
General Information	6
Planning the Floor Feeding System	7
General Installation Information	8
Laying out the Suspension System	8 - 9
Installing the Suspension System	9 - 13
Power Lift Winch Installation.	9
Installing the Main Winch Cable	10
Screw Hook Installation	11
Pan Assembly procedure for Model H2 Plus Feeder	13 - 15
Assemble Feed Cone and Support Cords	13
Assemble the Feed Cone and Center Support	14
Assemble the Center Support and Feed Cone to Feed Pan.	14
Feeder Line Assembly & Suspension	15 - 28
Feeder Pan and Tube Assembly Process	15
Assemble and Suspend the Feeder Line	16
Auger Installation	18
Auger Brazing.	23
Feed Line Winch Assembly	23
Anti Roost Installation	26
Intermediate Control	29
Model H2 Plus Feeder Management and Operation	32 - 34
Floor Feeding System Maintenance	35
Mechanical Switch Adjustment Procedure	36
SENSOR Plus Sensor Switch Time Delay Adjustment	36
Feeder Line Maintenance	36
Power Lift Winch Maintenance	37
Trouble Shooting the Floor Feeding System	38
Wiring Diagrams: Single Phase (Ø)	39 - 41
SENSOR Plus Wiring Diagram	39

SENSOR Plus Control Wiring Diagram.	39
Mechanical Switch Single Phase Wiring Diagram.	40
Mechanical Switch Single Phase Wiring Diagram (w/Motor Starter)	40
Mechanical Switch Three Phase Wiring Diagram (220 V.)	41
Mechanical Switch Three Phase Wiring Diagram (380/415 V.)	41

Parts Listing 42 - 57

100# Hopper Components	42
200 # Hopper Components	42
Hopper Boot Suspension Bracket	43
Single Boot Components Part No. 6822.	44
Twin Boot Components Part No. 6824.	44
Feeder Line Components	45
Winch Kit	46
Poultry Trainers and Line Chargers	46
Model H2 Plus Feeder Assembly with Cords.	47
Model H2 Plus Feeder Assembly without Cords	47
Removable Top Model H2 Plus Feeder Assembly with Cords	48
Removable Top Model H2 Plus Feeder Assembly without Cords.	48
Power Unit Assemblies.	49
Power Unit Assembly Part Numbers:	49
Model H2 Plus Mechanical End Control	50
Model H2 Plus Proximity End Control.	51
Model H2 Plus Mechanical Intermediate Control	52
Model H2 Plus Intermediate Control with Sensor Plus Switch	53
47687 Power Winch	54
Miscellaneous Suspension Components.	55

About this Manual

The intent of this manual is to help you in two ways. One is to follow step-by-step in the order of assembly of your product. The other way is for easy reference if you have questions in a particular area.

Important: Read ALL instructions carefully before starting construction.

Important: Pay particular attention to all SAFETY information.

- *Metric measurements are shown in millimeters and in brackets, unless otherwise specified. (") equals inches and (') equals feet in measurements.*

Examples:

1" [25.4]

4' [1 219]

- Optional equipment contains necessary instructions for assembly or operation.
- Major changes from the last printing will be listed on the back cover.



- This Planning Symbol is used in areas where planning needs to take place before construction continues.

- Very small numbers near an illustration (*i.e.*, 1257-48) are identification of the graphic, not a part number.

Safety Information

Caution, Warning and Danger Decals have been placed on the equipment to warn of potentially dangerous situations. Care should be taken to keep this information intact and easy to read at all times. Replace missing or damaged safety decals immediately.

Using the equipment for purposes other than specified in this manual may cause personal injury and/or damage to the equipment.

Safety–Alert Symbol



This is a safety–alert symbol. When you see this symbol on your equipment, be alert to the potential for personal injury. This equipment is designed to be installed and operated as safely as possible...however, hazards do exist.

Understanding Signal Words

Signal words are used in conjunction with the safety–alert symbol to identify the severity of the warning.



DANGER indicates an imminently hazardous situation which, if not avoided, **WILL** result in death or serious injury.



WARNING indicates a potentially hazardous situation which, if not avoided, **COULD** result in death or serious injury.



CAUTION indicates a hazardous situation which, if not avoided, **MAY** result in minor or moderate injury.

Safety Information

Follow Safety Instructions

Carefully read all safety messages in this manual and on your equipment safety signs. Follow recommended precautions and safe operating practices.

Keep safety signs in good condition. Replace missing or damaged safety signs.

Decal Descriptions

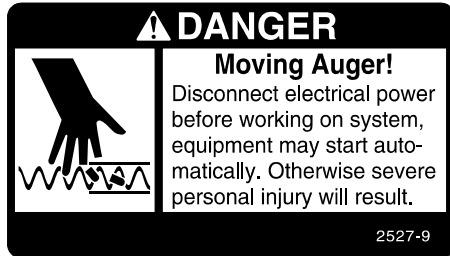

DANGER: Moving Auger

This decal is placed on the Panel Weldment.

Severe personal injury will result, if the electrical power is not disconnected, prior to servicing the equipment.

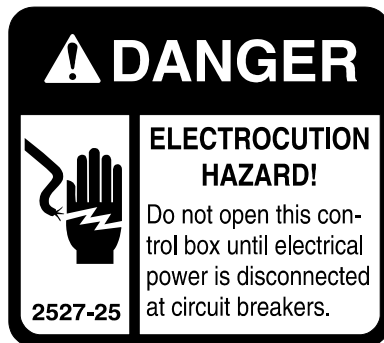

DANGER: Electrical Hazard

Disconnect electrical power before inspecting or servicing equipment unless maintenance instructions specifically state otherwise.

Ground all electrical equipment for safety.

All electrical wiring must be done by a qualified electrician in accordance with local and national electric codes.

Ground all non-current carrying metal parts to guard against electrical shock.

With the exception of motor overload protection, electrical disconnects and over current protection are not supplied with the equipment.

CAUTION:

Use caution when working with the Auger—springing Auger may cause personal injury.

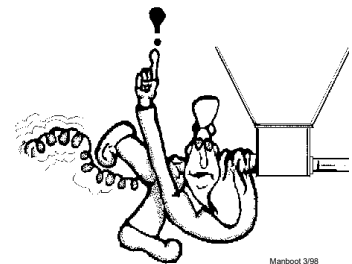

General Information

Support Information

The Chore-Time MODEL H2® Plus Feeding System is designed to feed poultry feed types. Using this equipment for any other purpose or in a way not within the operating recommendations specified in this manual will void the warranty and may cause personal injury.

This manual is designed to provide comprehensive planning and installation information. The Table of Contents provides a convenient overview of the information in this manual.

Planning the Floor Feeding System

1. Select the House Layout.

- A. Optional Mid Line Controls may be used for partial house brooding. See **Figure 1**.

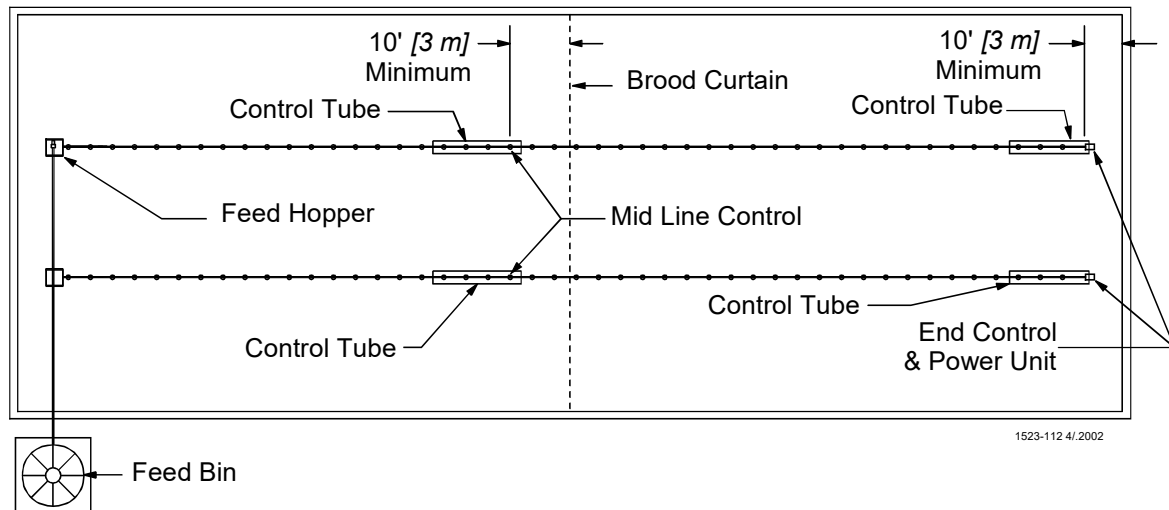

Figure 1. Component location diagram for systems up to 400 feet [122 m]. (Top View).

- B. Systems with line lengths over 400' [122 m] should be split in the center, as shown in **Figure 2**. This will reduce auger running time and eliminate the need for Mid-Line Controls for partial house brooding.

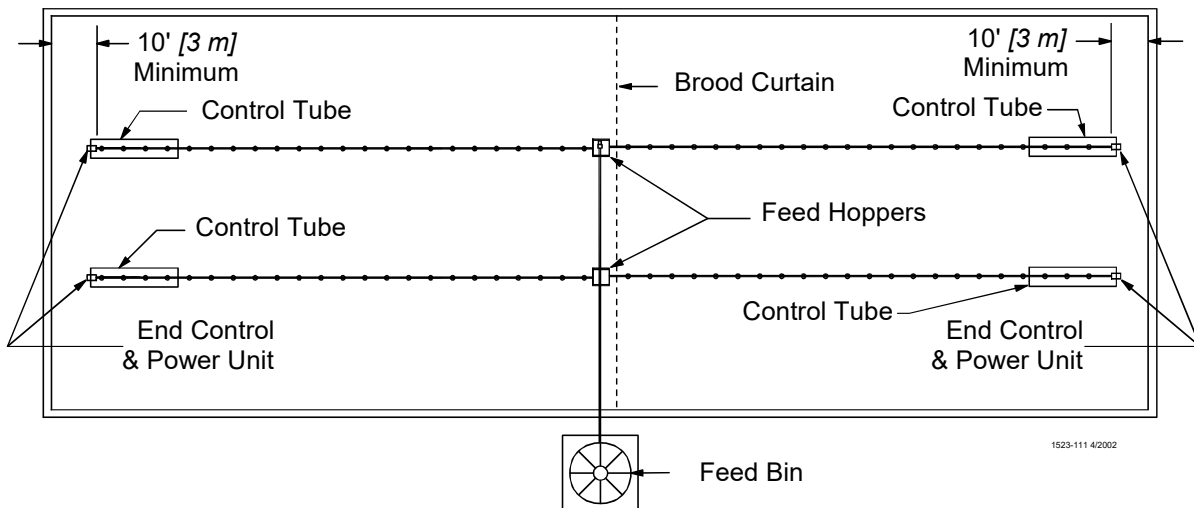

Figure 2. Component location diagram for systems over 400 feet [122 m]. (Top View).

2. Determine the Feed Bin location.
3. Determine the Brood Curtain location.
4. Determine the location for the End Control Pans, and if used the Mid Line Control Pans. **The Feeder Control Pans should be at least 10' [3 m] from the Wall or Brood Curtain.**
5. Determine the distance to the Feeder Line from the Side Wall.
6. Determine the distance from the Feed Hoppers to the End Wall for a Straight Line Feeding System.

General Installation Information

Please read the installation instructions in this manual prior to beginning the installation. This manual provides the necessary information on the installation, operation, and maintenance of the Chore-Time feeding equipment you have purchased.

The Model H2 Plus Control Unit uses a 348 RPM. Gearhead, delivering approximately 17 lbs [7.7 kg] per minute. This rating is based on feed with a density of 40 lbs per cubic foot [640 kg per cubic meter].

Single phase 60 Hz and single and three phase 50 Hz Power Units are available for the Model H2 Plus Feeder. Systems up to 300' [91 m] require 1/3 HP Power Units. Systems over 300' [91 m] require 1/2 HP Power Units.

Laying out the Suspension System

1. Select the Suspension type.
 - A. For systems up to 350' [107 m]

Figure 3. Suspension for systems up to 350' [107 m]

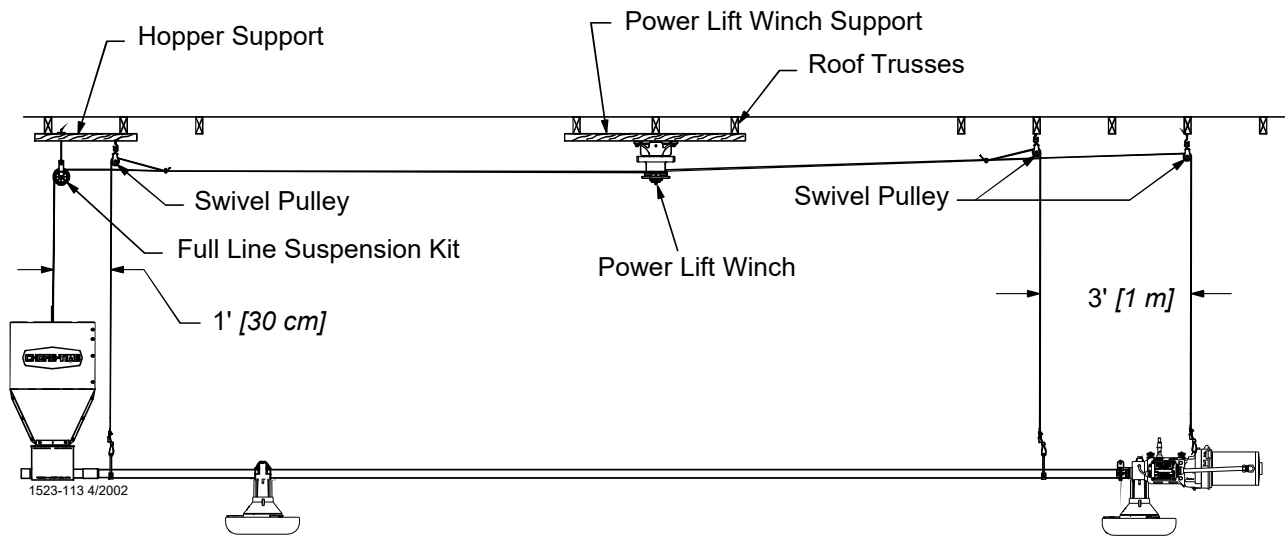

B. For systems over 350' [107 m]

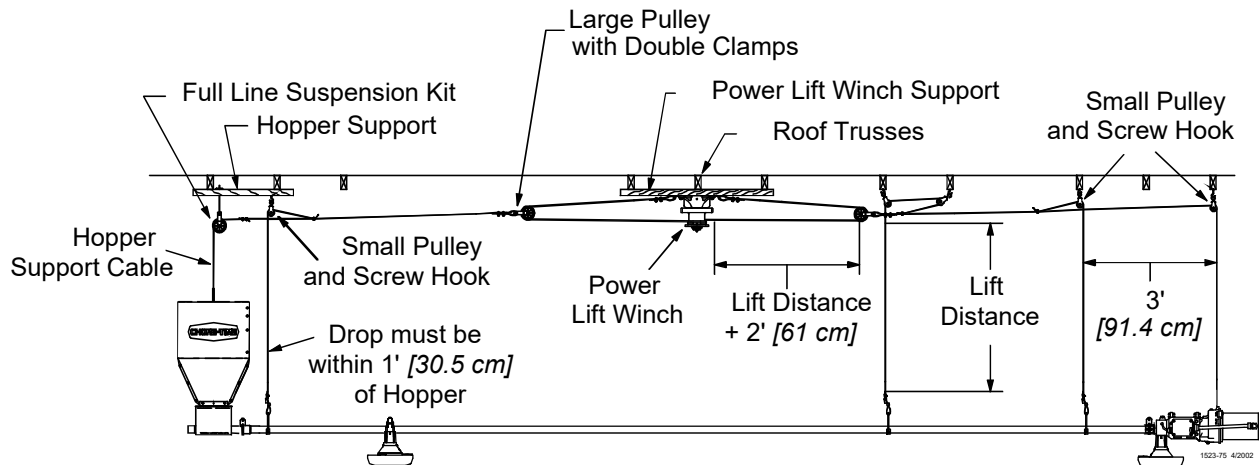

Figure 4. Suspension for systems over 350' [107 m]

2. Locate the Power Lift Winch. The Power Lift Winch requires a support that will span, in a wood frame house at least 3 rafters, and in a steel frame house at least 2 rafters.
3. Locate the Power Unit and Feed Hopper. Special support is required at each Power Unit and Feed Hopper location.
4. Determine the drop location and length. Suspension systems are based on ceiling heights of 14' [4.3 m]. DO NOT EXCEED 10' [3 m] BETWEEN SUSPENSION DROPS.
5. Determine the location for the Screw Hooks. Mark a straight line or use cable to locate Screw Hooks. Use the offset of Screw Hooks where necessary.

Installing the Suspension System

Power Lift Winch Installation

1. Bolt the Power Winch, fully assembled, to the Power Lift Winch Support, either a 2" x 8" [50x200 mm] board that will span at least 3 rafters or a 3/8" [9.5 mm] thick steel plate welded to two pieces angle iron that are each long enough to span at least 2 rafters, using 5/16-18 hardware supplied in the Hardware Package. The brake mechanism will extend toward one side. See Figure 5.

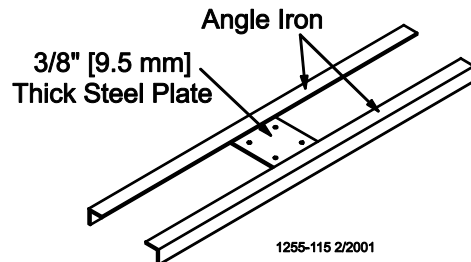

Figure 5. Optional Power Lift Winch support detail

Install a Cable Hook, supplied in Hardware Package, between the mounting bolt and Power Winch frame, as shown in Figure 6.

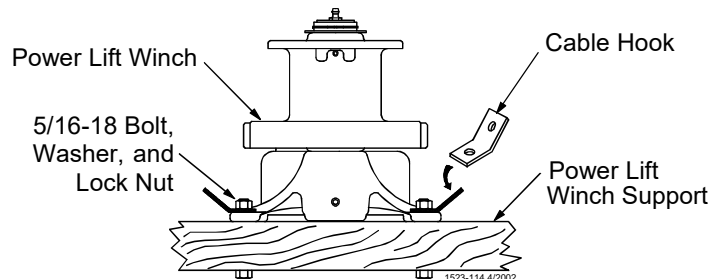

Figure 6. Assembling the Power Winch to the Rafters

- Attach the Power Lift Winch Support (with the Power Winch secured) to the ceiling at the center of the feeder line. See **Figure 7**. The Power Lift Winch Support must be parallel to the feeder line and must span at least 3 rafters in a wood frame house and 2 rafters in a steel frame house.

If the hopper is located at the center of the feeder line, locate the Power Winch a few feet offset from the center of the feeder line. However, the Winch Drum must be directly in line with where the main cable is to be installed.

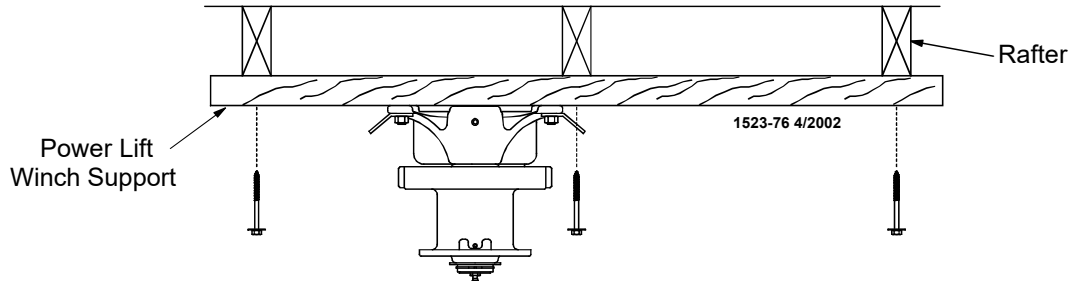

Figure 7. Mounting the Power Lift Winch and support to the rafters.

Installing the Main Winch Cable

The Suspension Systems are based on ceiling heights of 14' [4.3 m] with Suspension Drop points every 8' [2.4 m]. DO NOT EXCEED 10' [3 m] BETWEEN SUSPENSION DROPS. Refer to suspension section in this manual for installation details.

Adequate overhead structure must be provided to support the weight of the feeders, hoppers, power units, etc. The type of installation required depends on the feeder line length.

IMPORTANT: Special support is required at each Hopper location

- Power Unit Locations: **The Feeder Line must be supported within 3' [0.9 m] of the Power Unit.** This is in addition to the required Power Unit suspension. If the Control Unit or Hopper does not come out directly under a truss, fasten a pulley to a 2" x 8" [50 x 200 mm] board or steel angle that will span 2 trusses and is capable of supporting 300 lbs [136 kg] for the Hopper and 75 lbs [34 kg] for the Control Unit.
- Feed Hopper Locations: **The Feeder Line must be supported within 1' [30 cm] of the Feed Hopper.** This is in addition to the required Feeder Hopper suspension. After determining the type of suspension system required, decide where the Feeder Line is to be installed. Mark a straight line on the ceiling or rafters the full length of the Feeder Line. Use a string, chalk line, or the winch cable, temporarily attached with staples, to mark the line. Center the line directly over where the Feeder Line is to be installed.

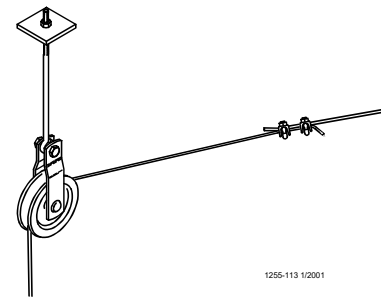

Figure 8. Full line suspension kit

- Extend the 3/16" [5 mm] Main Winch Cable the full length of the feeder line. Attach the cable temporarily to the ceiling with nails, staples, or some type of fasteners. **Figure 9** shows a double back arrangement for feed lines over 350' [107 m]

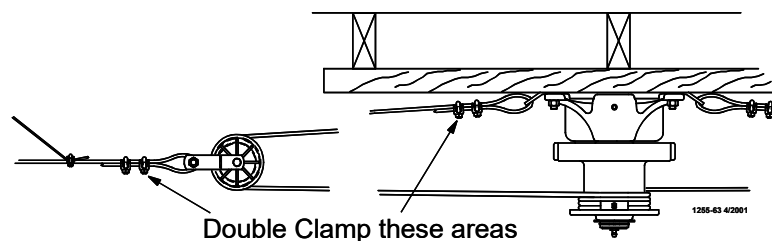

Figure 9. Double back arrangement for feed lines over 350' [107 m]

- Route the cable through the Winch Drum Relief located near the bottom of the drum. Tighten the set screw to anchor the cable to the drum. See Figure 10.

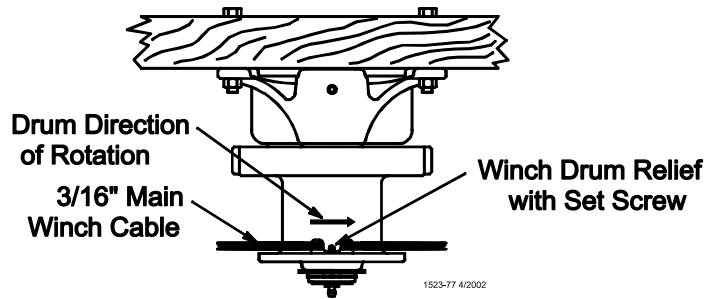

Figure 10. Attaching the cable to the Power Winch

- Turn the winch drum one full revolution. Guide the cable against the flange at the bottom of the winch drum. The cable must not wrap over itself on the drum, but should be wrapped as close as possible to each previous wrap. See Figure 11.

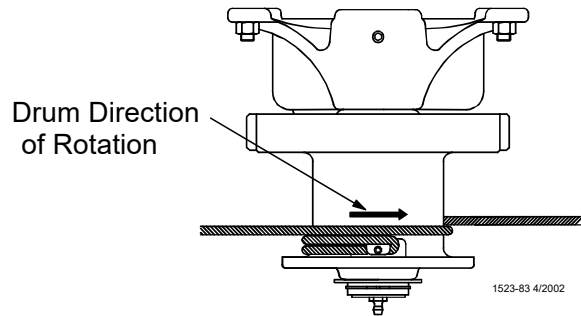

Figure 11. Power Winch Drum Rotation

Screw Hook Installation

The recommended distance between the drops for the Model H2 Plus is 8' [2.4 m] on center. Do not exceed 10' [3 m] spacing on drop lines.

If the distance raised is greater than the distance between the drop spacings, offset the hooks 3" [7.6 cm] to each side of the line to prevent the cable clamps from catching the pulleys. See Figure 12.

Screw the hook into the truss the full length of the threads to prevent bending.

The openings of the screw hooks must be pointed away from the direction of travel when the Power Winch raises the feeder line.

See Figure 13.

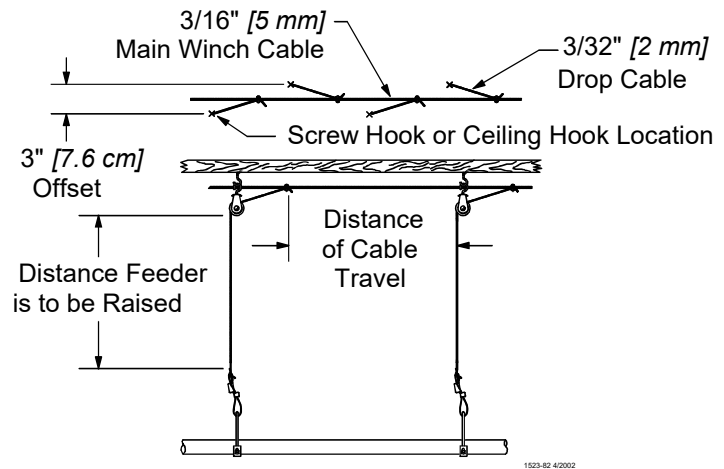

Figure 12. Drop line off set detail

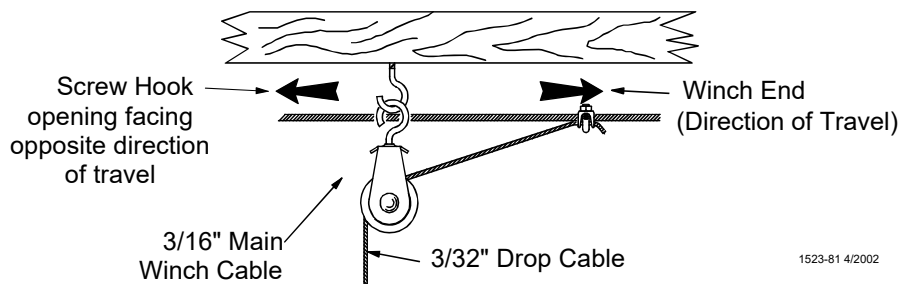

Figure 13. Screw Hook Installation

Ceiling Hook Installation

The ceiling hook may be used in a variety of installations. Depending on your ceiling or rafter type, install the Ceiling Hooks as shown in **Figures 14 - 17**.

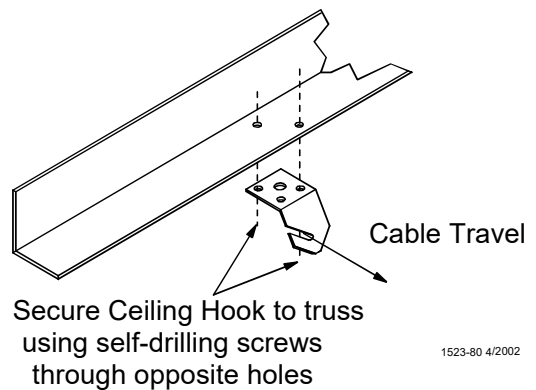

Figure 14. Steel Truss Ceiling Bracket Installation

Steel Truss Installations

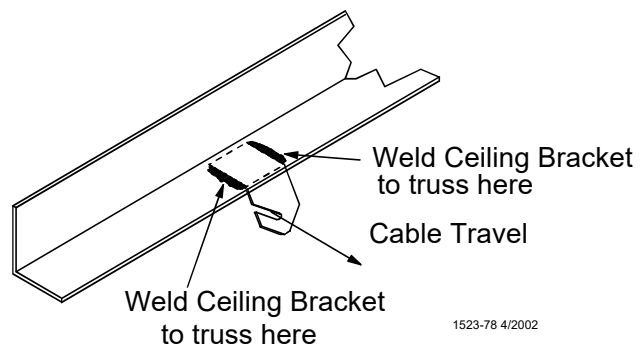

Figure 15. Welded Steel Truss Ceiling Bracket Installation

Wood Truss Installations

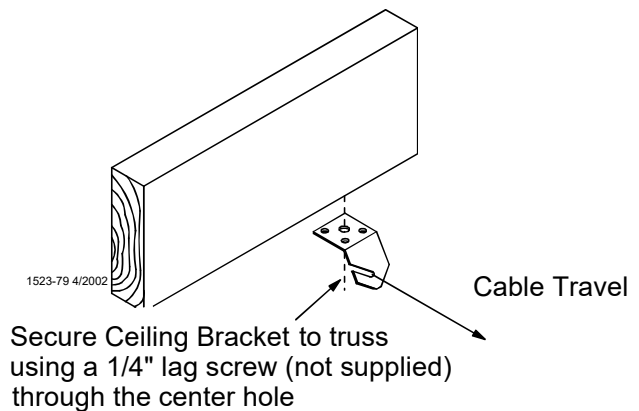

Figure 16. Wood Truss Ceiling Bracket Installation

- After securing the Ceiling Hook to the truss, slide the hook of a Swivel Pulley into the slot, as shown in **Figure 17**.

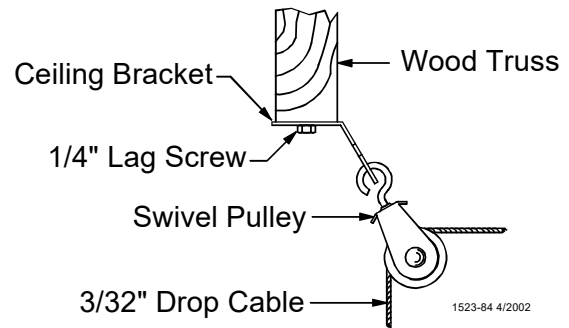

Figure 17. Pulley Installation

Drop Installation

Refer to **Figure 12** on page 11.

- Attach a 3004 Pulley to each hook.
- Thread the end of the 3/32" or 1/8" cable through the pulley toward the winch. Clamp this end to the 3/16" winch cable about 6" [150 mm] from the last pulley, using a 3/16" cable clamp. See applicable figure; **Figure 13 or 17**.
- Allow enough cable length for installation of the Adjustment Leveler.
Sufficient cable is included to provide "throwbacks" on drops located beneath and near the winch. **Figure 18** shows a "throwback" cable arrangement

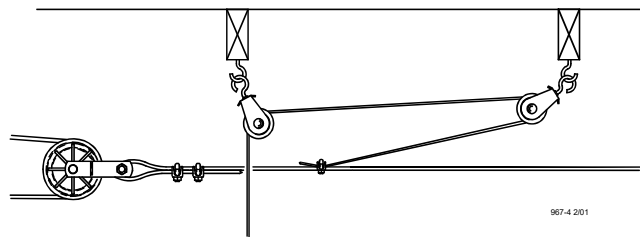

Figure 18. "Throwback" cable arrangement

- Begin installing suspension drops at the winch and proceed to the end of the feeder line. Keep the main cable tight between drops. It may be necessary to hang a weight on the end of the cable to maintain tension on the line.

Pan Assembly procedure for Model H2 Plus Feeder

Assemble Feed Cone and Support Cords

With the large end of the Feed Cone up, slide the straight end of the Support Cord in the openings on each side of the Feed Cone. See **Figure 19**.

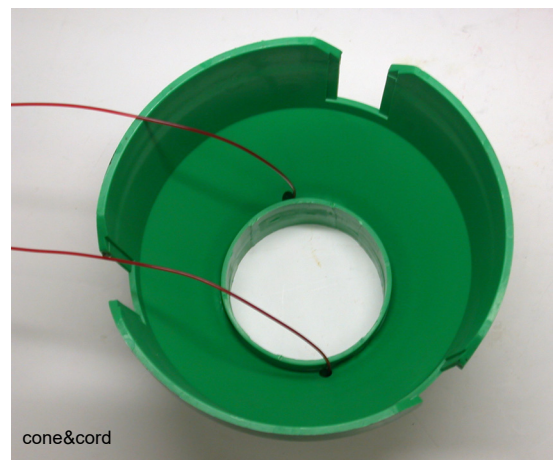

Figure 19. Assembling Support Cord to Feed Cone

Connect the two ends of the Support Cords together with the Cable Clamp. This will keep the cords from sliding back through the hole while the remainder of the feeder is assembled. See **Figure 20**.

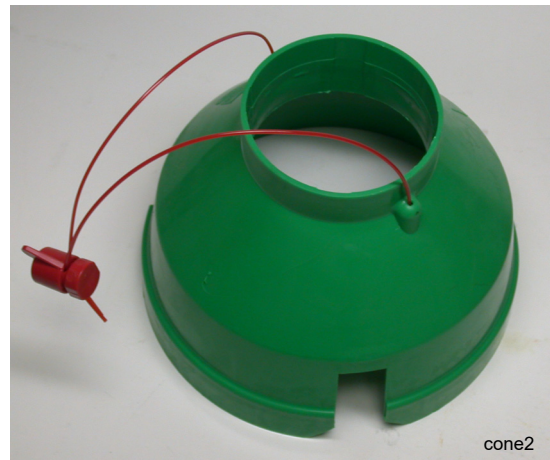

Figure 20. Assembling Support Cord to Feed Cone

Assemble the Feed Cone and Center Support

Align the three legs of the Center Support and the three tabs on the Feed Cone. Align the arrow on the Feed Cone with the part number on the Center Support. Start the tabs in the three legs, apply down pressure the tabs should snap into the legs of the Center Support. See **Figure 21**.

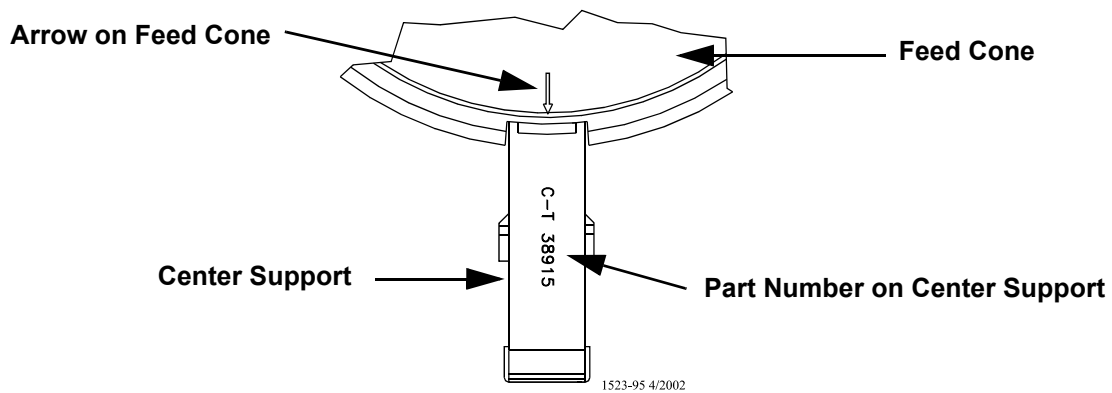

Figure 21. Assembling Support Cord to Feed Cone

Assemble the Center Support and Feed Cone to Feed Pan

1. Broilers: Position the lip of the feeder pan in the #2 tab of 2 of the struts. See **Figure 22**.

Turkeys: Position the lip of the feeder pan in the #4 tab of 2 of the struts. See **Figure 22**.

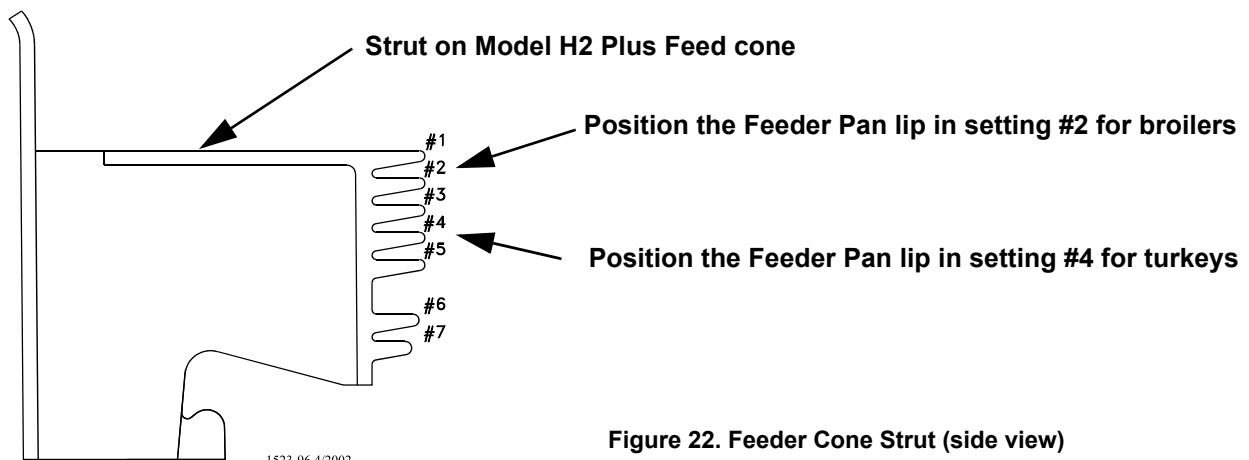

Figure 22. Feeder Cone Strut (side view)

2. Pull the pan, as shown in **Figure 23**, so that the lip of the pan will be in the proper setting on the third strut.



Figure 23. Assembling the Center Support and Feed Cone to the Pan.

3. Build all the required Feeder Assemblies for the house.
The Feeder Assemblies will be installed on the auger tubes in the Feeder Line Installation section.
4. Remove the Cable Clamp from the Support Cords. Route the Support Cords through the cable guides on the side of the Center Support. With the Support Cords above the feed tube, place the Cable Clamp on the Support Cords. See **Figure 24**.

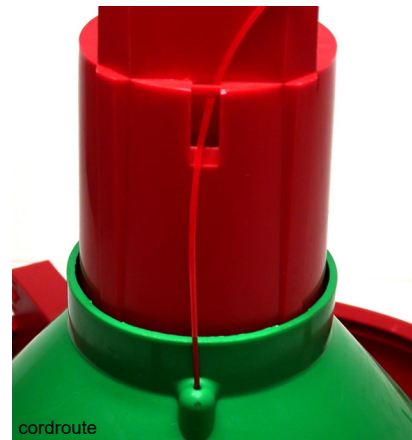

Figure 24. Assembling Support Cord to Feed Cone

Feeder Line Assembly and Suspension

Feeder Pan and Tube Assembly Process

1. Slide one Feeder Pan Assembly per hole onto the auger tubes.
IMPORTANT: Install all the feeders on the tubes in the same orientation.
When sliding the feeders on the tubes, make sure the grill openings are on the same side of the tube.
2. Rotate the auger tubes so that the seam is down, this holds the Pan Assemblies in place on the tubes. See **Figure 25**.

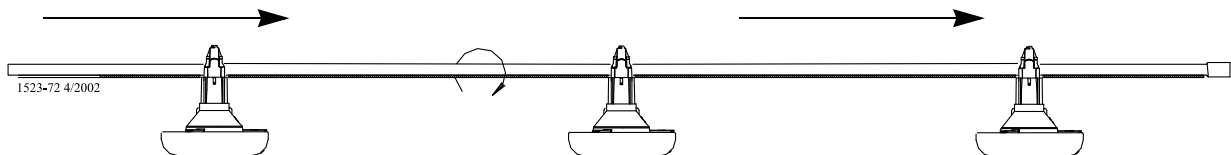

Figure 25. Assembling Feeders on the Tubes

Assemble and Suspend the Feeder Line

1. The auger tubes and feeders may be laid out end to end in approximately the final location of the line. **The belled end of each tube should be toward the Hopper end of the line.** See **Figure 26**.
2. Connect the individual feeder tubes together by inserting the straight end of one tube as far as possible into the belled end of the next tube. **The last Feeder Tube before the End Control Pan or Mid Line Control pan needs to be a Control Tube.**

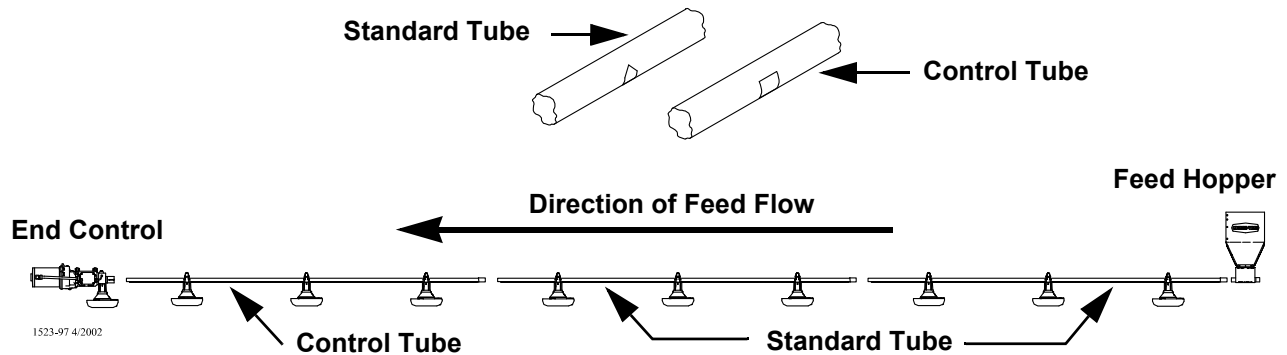

Figure 26. Assembling Feeders on the Tubes

3. To achieve total feed drop out all along the system, the Chore-Time Logo should be centered at the crown of the tubes and all the Hangers should be installed as shown in **Figure 27**.

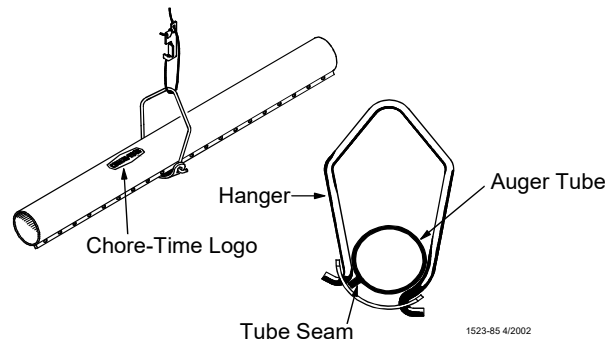

Figure 27. Assembling Feeders on the Tubes

4. Place a Tube Clamp Assembly or Clamp/Anti-Roost Bracket at each joint. **Figure 28** shows the standard Clamp and Clamp/Anti-Roost Bracket. Systems using 9' or 10' tubes require a Clamp/Anti-Roost Brackets every fifth joint.

Systems using 12' tubes require a Clamp/Anti-Roost Bracket at every fourth joint. All other joints in the system use the standard Tube Clamp Assembly.

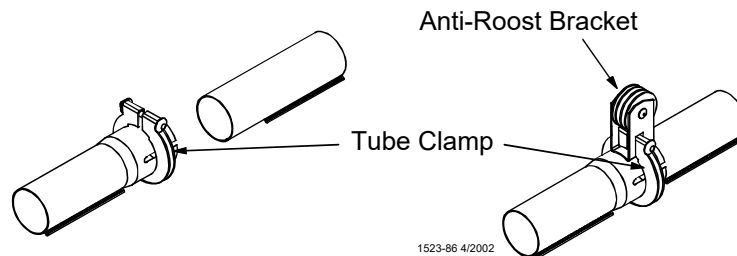

Figure 28. Assembling Feeders on the Tubes

Continue down the entire length of the feeder line so that every joint is secured with a standard Clamp or Clamp/Anti-Roost Bracket. **Figure 29** shows the proper clamp location on the tube joint. Do not tighten the clamp at this time.

5. Install the Hangers on the feed line tube at the 8' [2.4 m] spacings determined by the suspension drop lines. **Figures 27 and 30** show the proper installation of the Hanger Assembly. Make sure the outlet drop hole is downward when the Hangers are installed, otherwise feed will not be allowed to drop into the feeder pan.
6. Install Adjustment Leveler within 6" [152 mm] of feeder line. **Figure 31** shows the proper cable routing around the Adjustment Leveler.
7. Following the installation of all drops, check drop cables before raising feeder line. Cable must be tracking properly on all pulleys before raising the feeder line.
8. Raise the feeder line to a convenient working height.
9. With the feeder line suspended, measure from the floor or ceiling to the auger tubes to level the system.
10. Before tightening each clamp:
 - make sure each tube is level (not sagging, sloping, etc.).
 - make sure straight end of each tube is fully inserted in belled end of next tube.
 - if providing total drop out, tubes should be rotated so that the Chore-Time Logo is on crown of tube.
 - make sure the clamps are located, as shown in **Figure 29**.

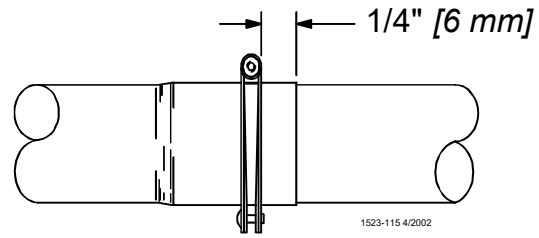

Figure 29. Assembling Feeders on the Tubes

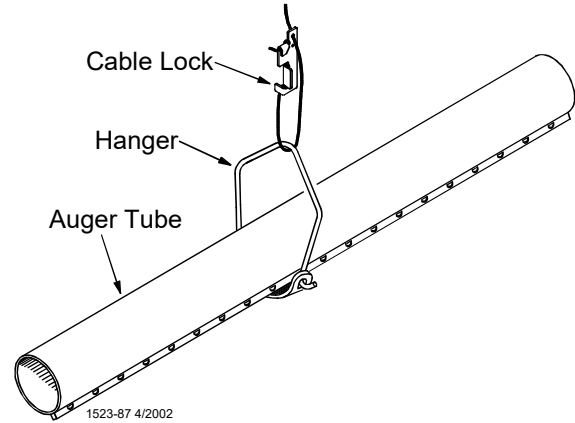

Figure 30. Assembling Feeders on the Tubes

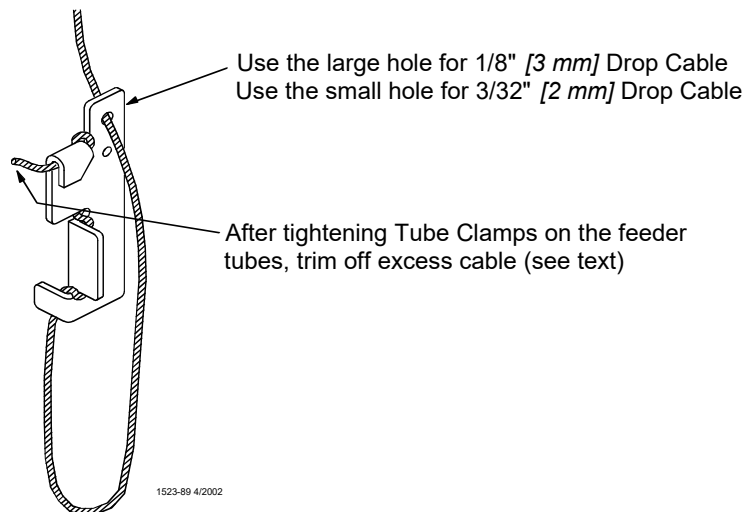

Figure 31. Assembling Feeders on the Tubes

Finally, tighten the Tube Clamps on the feeder tubes. Clamp the joints securely, but do not crush the tubes. Re-adjust all Adjustment Levelers as needed and trim off excess cable as shown in **Figure 31**.

Installing the End Control, Boot Assembly, and Auger

The End Control Unit must be at least 10 feet [3 m] from the end of the building to allow birds access around the end of the feeder line.

1. Assemble the End Control Unit to the Feeder Line Control Tube using a clamp/anti-roost bracket. See **Figure 32**. **DO NOT INSTALL THE POWER UNIT AT THIS TIME.**

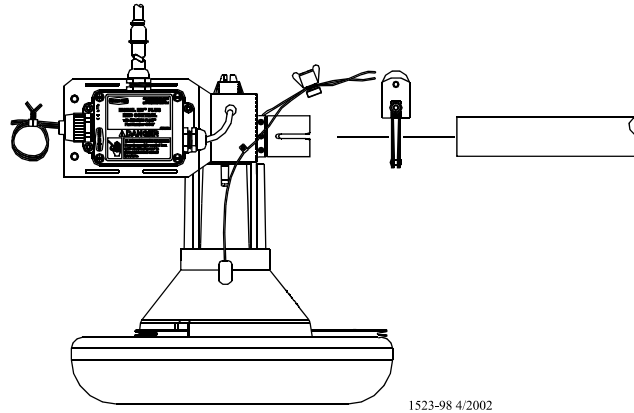

Figure 32. End Control Installation

2. Install the Feeder Boot by sliding the straight end of the Feeder Boot into the belled end of the Feeder Tube. Install a clamp/anti-roost bracket on the bell and tighten. The Feeder Boot must be level with the open top of the Feeder Boot flat. See **Figure 33**. **DO NOT INSTALL THE ANCHOR BEARING AND BEARING RETAINER AT THIS TIME.**

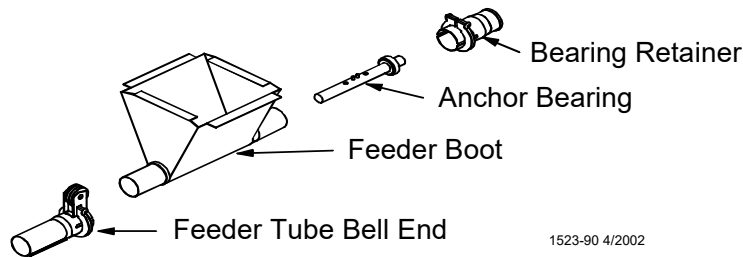
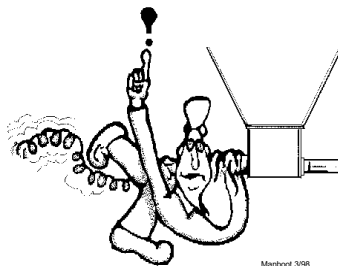

Figure 33. Installing the Feeder Boot

Auger Installation

Note: Use extreme caution when working with the auger. The auger is under tension and may spring causing personal injury. Wear protective clothing, gloves, and safety glasses when working with the auger.



**BE CAREFUL WHEN
WORKING WITH THE
AUGER!**

To avoid kinking the auger, be careful not to drop the rolled auger when handling. Inspect the auger carefully as it is installed. Small kinks may be straightened. Large kinks must be removed and the auger brazed back together.

Cut the leading 18" [450 mm] and last 18" [450 mm] off each roll of auger. Also, cut out any other distorted auger sections and reconnect the auger as specified in the Auger Brazing section of this manual.

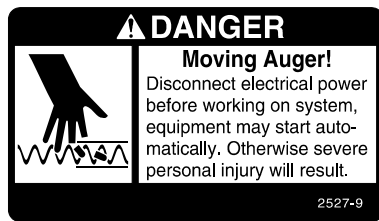

- 1 Use extreme caution when pushing the auger into the auger tubes. Keep your hand away from the end of the auger tube to avoid injury.
With the auger coiled about 6 feet [1.8 m] from the end of the boot, uncoil the auger from the outside and feed the auger through the boot into the tubes.
Push the auger into the tube in short strokes.
Uncoil and handle the auger carefully to avoid damaging or kinking the auger.
2. If more than one coil is required for each feeder line, the auger ends will have to be brazed together. Refer to the Brazing the Auger section in this manual.
3. Install the Anchor Bracket to the Power Unit/Gearhead, as shown in **Figure 34**, with the included 5/16-18 Bolts

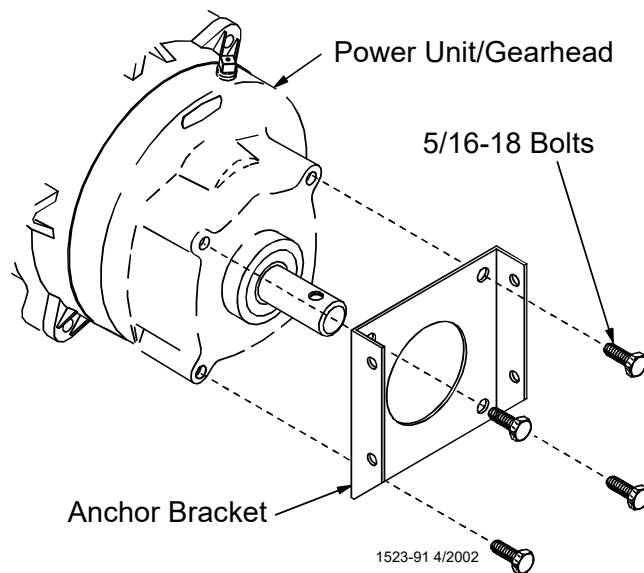

Figure 34. Installing the Feeder Boot

4. Slide the Drive Tube and flat washer over the output shaft on the Power Unit, as shown in **Figure 35**.
5. Continue installing auger until the auger reaches the Control Unit end of the feeder line.
6. Turn the Drive Tube Weldment into the auger, then attach to the output shaft of the Power Unit, as shown in **Figure 35**. Use the Driver Block to secure the auger to the Output Shaft

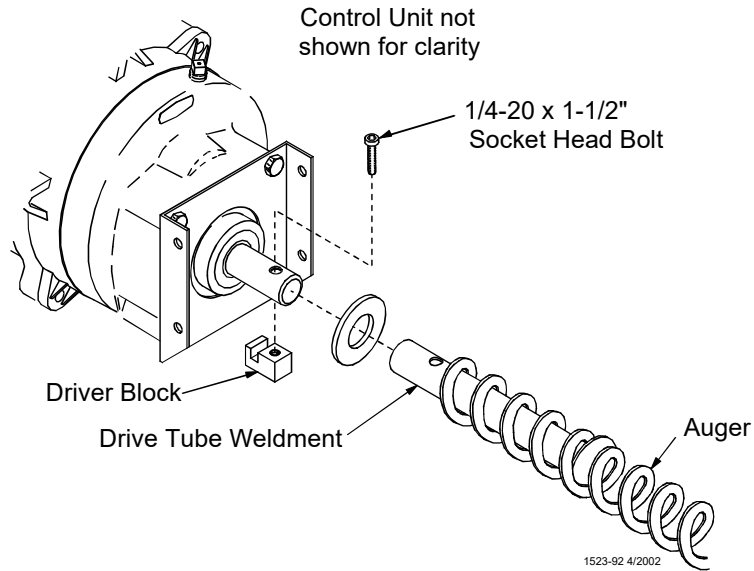

Figure 35. Auger Driver Components

7. Attach the Anchor Plate and Gearhead Assembly to the Control Unit Body using the included 1/4" lock washers and 1/4-20 x 1/2" Bolts. See **Figure 36**.

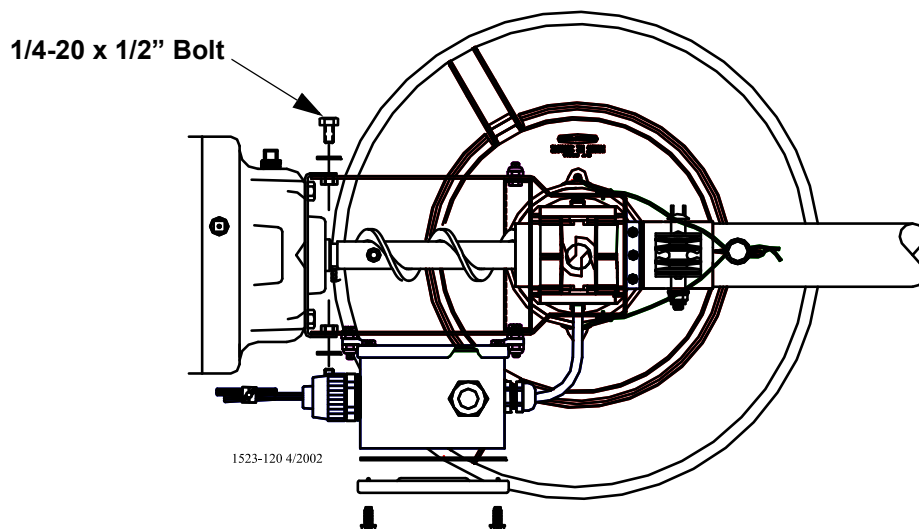

Figure 36. Attaching the Anchor Plate and Gearhead Assembly to the Control Unit Body

8. Install the Metal Water Tight Connector in the Feed Line Motor (single phase applications only). Cut the Flexible Conduit to length. Slide the wires from the end control through the Flexible Conduit. Install the Flexible Conduit in the connectors. Connect the wires to the Feed Line Motor.

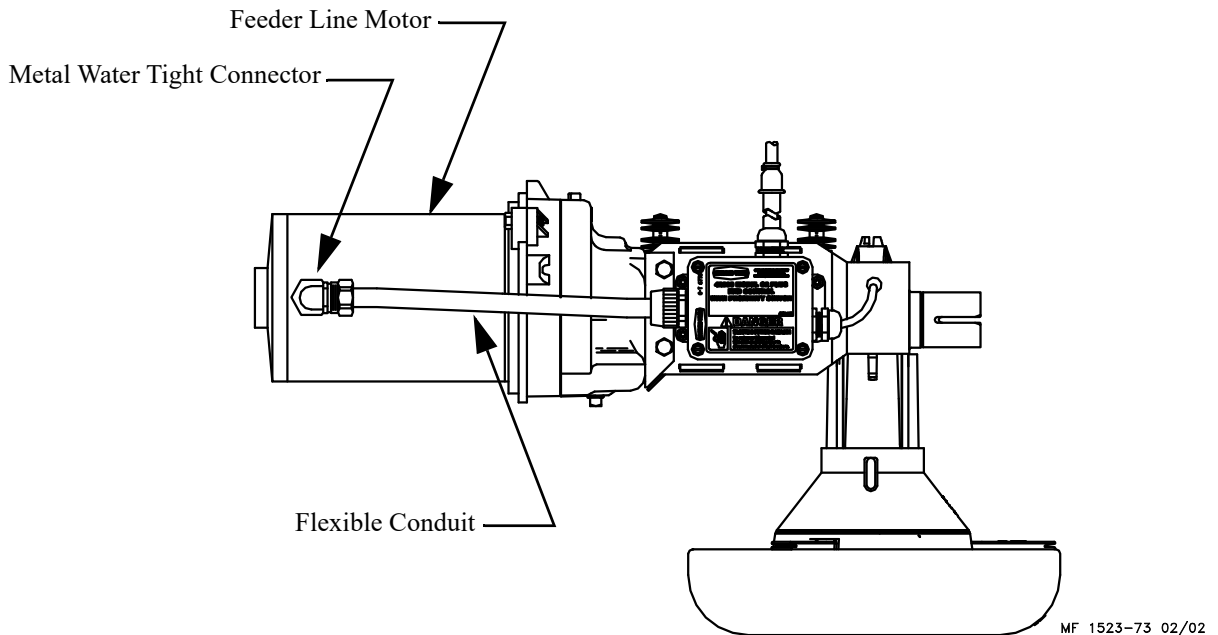

Figure 37. Wiring the Motor

9. Attach all covers and wires according to the wiring section of this manual.
10. Pull the auger at the boot end until it begins stretching. Then let it relax. In the relaxed position, mark the auger at the end of the boot. See Figure 38.

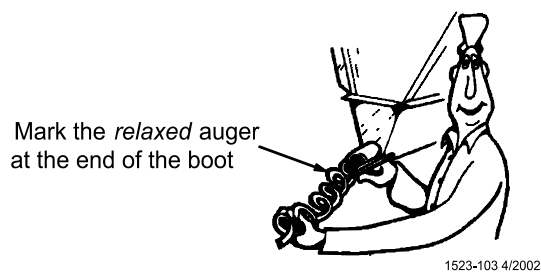

Figure 38. Wiring the Motor

11. Auger stretch:

The auger needs to be stretched 7" [180 mm] per 100' [30 m]. Example: A 300' [90 m] feeder line requires 21" [500 mm] of stretch.

Beginning at the *relaxed* position, measure the required amount of stretch. Mark the auger at that point.

Grip the auger 8" [200 mm] ahead of this mark with locking pliers. Allow the auger to pull back into the boot so that the pliers rest against the end of the boot. See Figure 39.

Use a hacksaw or bolt cutters to cut the auger at the stretched auger mark.

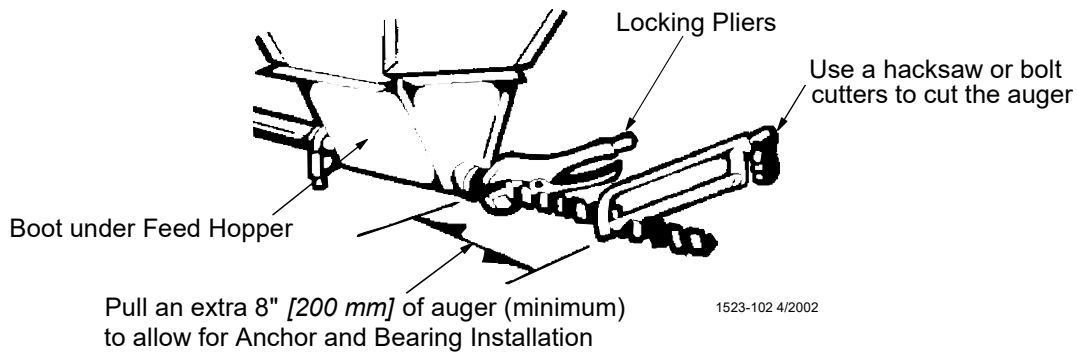

Figure 39. Cut the Auger with required stretch

12. Insert the Anchor Assembly into the auger until it touches the washer at the back of the anchor. Tighten the setscrews in the center of the anchor until they touch the auger, then tighten a maximum of 1/2 turn. See **Figure 40**.

DO NOT OVERTIGHTEN THE SET SCREWS

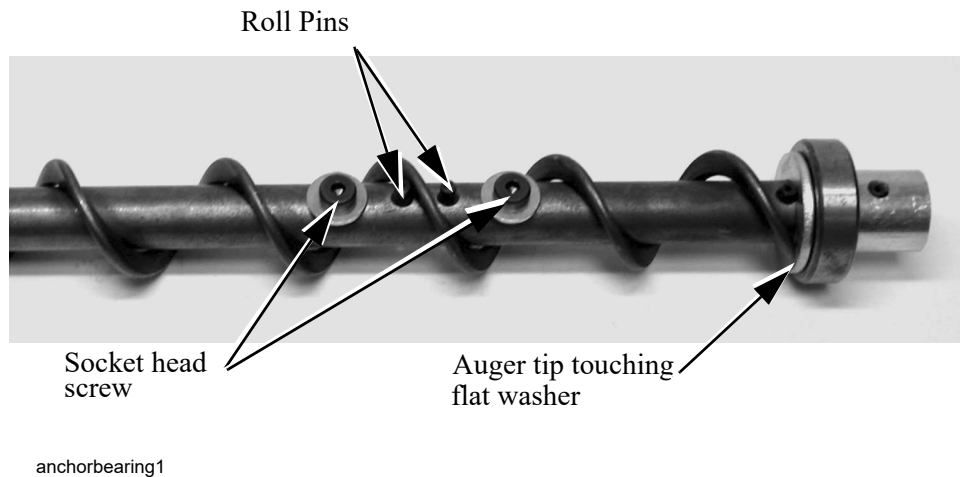

Figure 40. Wiring the Motor

13. **Carefully** remove the locking pliers while holding onto the Anchor and Bearing Assembly and auger securely.

Slowly ease the auger back into the tube. Use caution. If the auger is allowed to spring back, the bearing race may crack.

Install the Bearing Retainer and fasten with a tube clamp. Keep the Bearing Retainer flush with the end of the anchor for safety.

14. Place the cannonball in the boot.

Auger Brazing

The auger should be brazed if it is necessary to splice or lengthen it. A bronze, flux coated rod is recommended.

The ends of the auger should butt against each other, **DO NOT THREAD INSIDE EACH OTHER**. See **Figure 41**. The joint should be well filled with no sharp edges or rough corners to wear against the tube. To align the auger for brazing, lay it in angle or channel iron and clamp it firmly in place. Use low heat. Allow the joint to air cool; rapid cooling will cause the auger to become brittle.

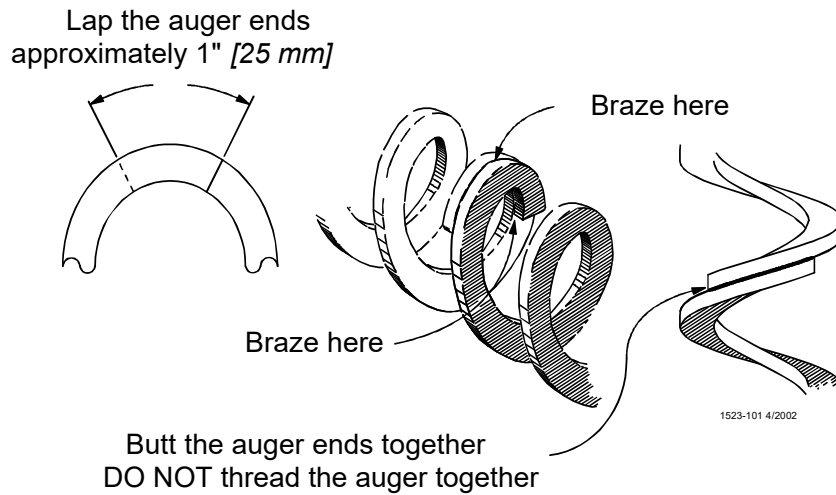

Figure 41. Brazing the Auger

Feed Line Winch Installation

Install the feed line winch in the center of the brood area. Remove one pan and use the Closure Kit to cover the outlet hole. Mount the winch using the band clamps supplied with the winch. Install the Insulator Pulley Assemblies as shown using the included Band Clamps. See **Figure 42**.

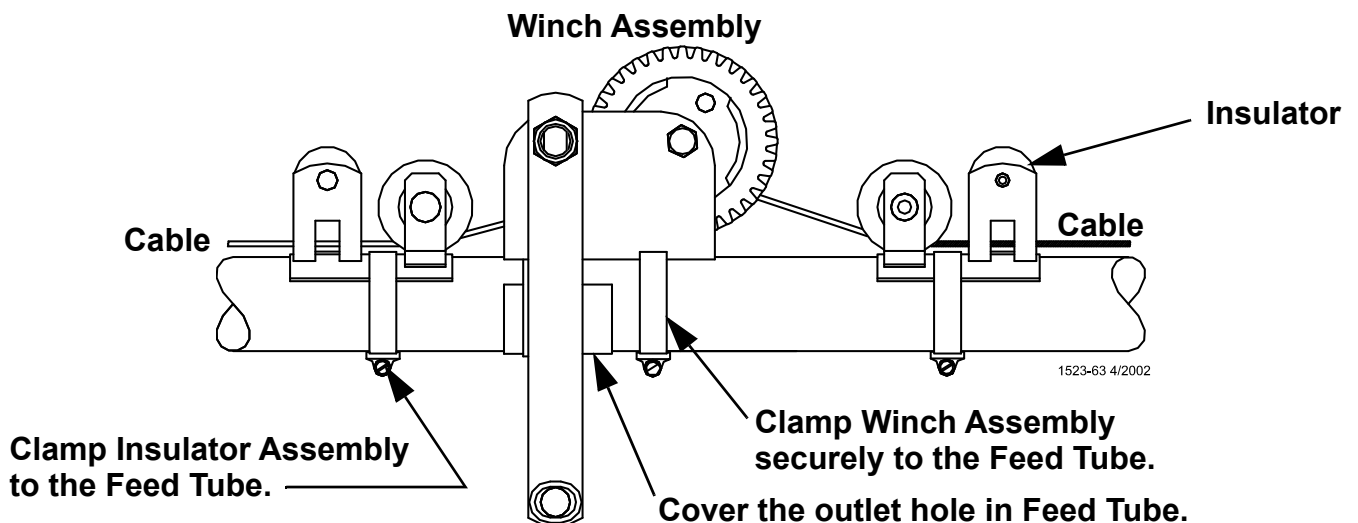

Figure 42. Winch Installation

Route the cable through the feed line winch drum. See **Figure 43**. Turn the Winch to put two wraps of cable on the drum.

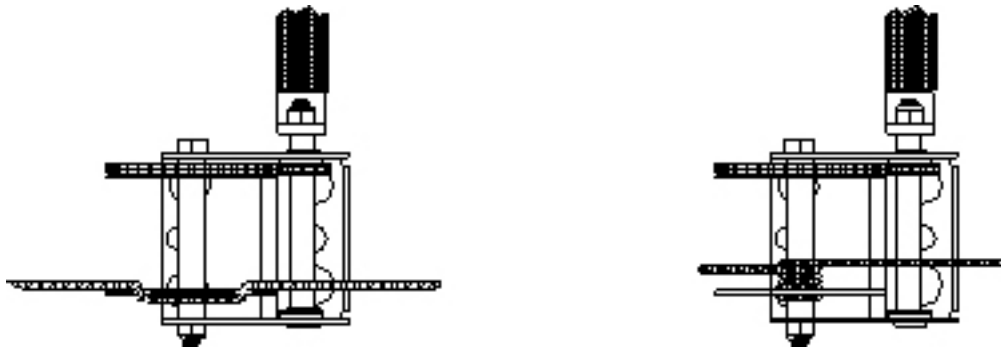

Figure 43. Cable routing through winch drum.

Starting at the Control End, thread the 3/32" cable through every Drop Tube to support the cable and keep it in position. See **Figure 44**.

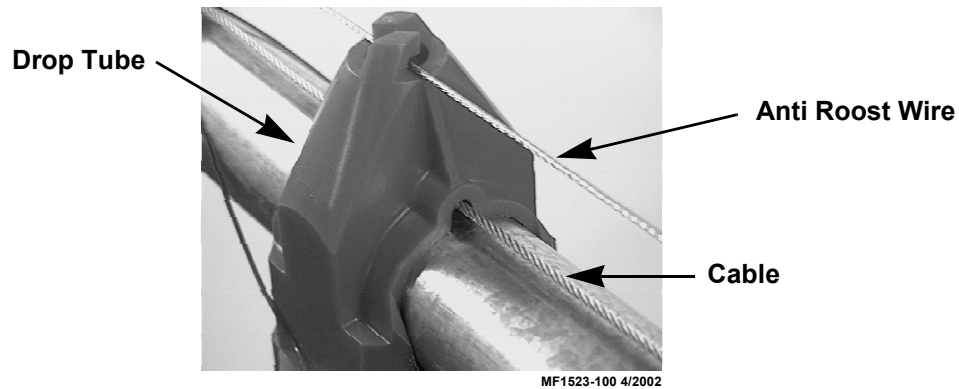

Figure 44. Cable routing through Drop Tubes

Assemble an insulator bracket and tube clamp at the ends of the brood area, one at the hopper and one at the control unit. Assemble the spring to the tube clamp as shown in **Figure 45**. Spring should have approximately 1" [25 mm] of stretch to maintain proper tension.

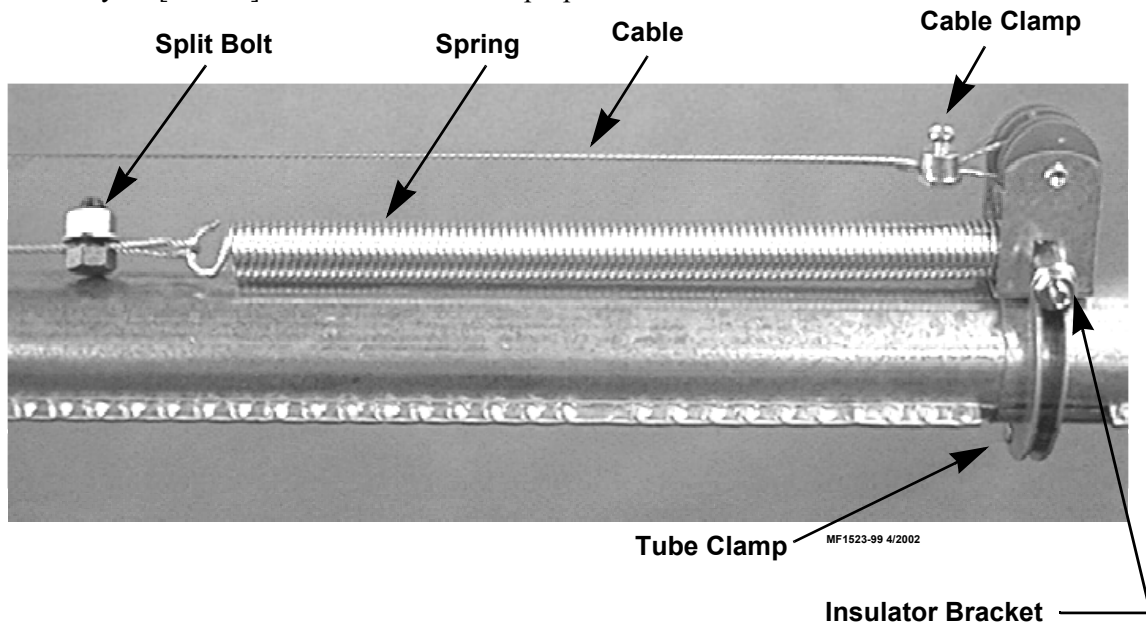

Figure 45. Insulator Bracket and Spring installation

Starting at the winch, connect one of the Support Cords to the lift cable. The cords must be routed toward the winch (center of the brood area).

Do not raise the first feed cone when connecting the cords.



1523-119

1523-119 4/2002

Figure 46. Connecting the Support Cords

See **Figure 47** for the proper way of connecting the cords to the cable

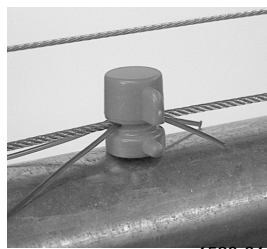

1523-61

Figure 47. Cable Clamp installation detail.

Using the Feed Line Winch, raise the Feed Cone to its highest position. Position a Cable Clamp next to the Insulator Pulley Assembly at the Feed Line Winch. This Cable Clamp is to indicate when the Feed Cones have reached their highest setting. There is to be only one Cable Clamp per Feed Line Winch. See **Figure 48**.

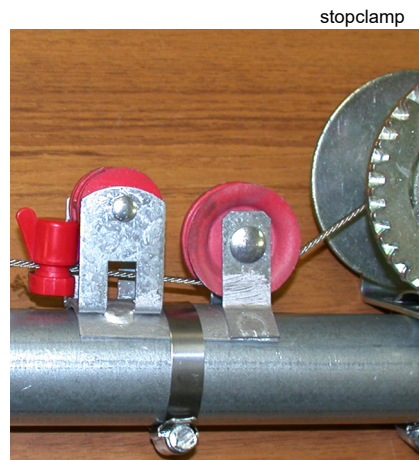

Figure 48. Support Cords installed

Continue to attach the remainder of the feeders to the lift cable, making sure the feeders are in their highest position when connected.

Remember to route the cords toward the Feed Cone Winch.

Anti-Roost Installation

1. Unroll the bulk anti-roost cable. Note: If the cable is unrolled as shown in **Figure 49**, taking 5 loops of the coil with one hand, then changing hands to remove 5 loops as it is unrolled, it will lie flat during installation.

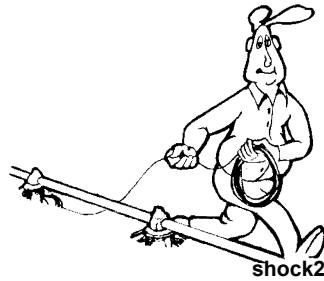

Figure 49. Unrolling the Cable

2. Start at the hopper end of the line and form a loop around the anti-roost bracket. For best results, make a double loop around the anti-roost insulator in the center groove of the insulator and fasten with a 1/16" cable clamp as shown in **Figure 50**.

Key	Description
1	Cable Clamp
2	Clamp with Insulator Bracket and Insulator
3	Anti-Roost Cable

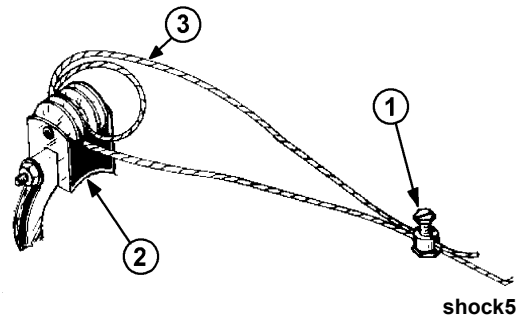
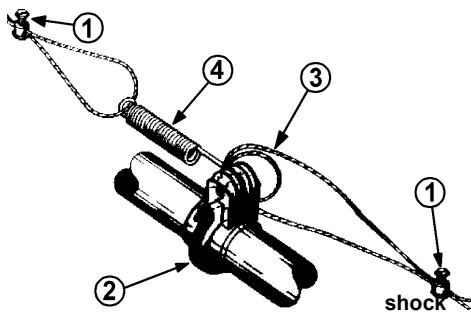

Figure 50. Anti-Roost Cable at the Hopper

3. Insert the cable in the insulator on the top of each Grill Support between the hopper and the next anti-roost bracket.
4. Attach a spring in the center groove at the second anti-roost bracket and cut the cable at this point. See **Figure 51**.
5. Thread the ends of the cable through the end of the spring. Pull the cable tight so that there is 3/4" to 1" (20 to 25 mm) of stretch in the spring. Clamp the cable to form a loop and cut off any excess. See **Figure 51**.
6. Attach the cable to the insulator. For best results, make a double loop around the anti-roost insulator in the center groove of the insulator and fasten with a 1/16" cable clamp as shown in **Figure 51**.



Key	Description
1	Cable Clamp
2	Clamp with Insulator Bracket and Insulator
3	Anti-Roost Cable
4	Spring should be stretched to 3/4" to 1" (19 to 25 mm).

Figure 51. Anti-Roost Cable Mid-Line Connection

7. Run the cable to the next insulator, attach a spring in the center groove at the anti-roost bracket and cut the cable at this point. The cable should be positioned in the insulator built into the top of each grill support along the feeder line.
8. Repeat this installation until the anti-roost cable is installed along the entire feeder line.
9. At the control unit, after clamping the cable to the spring, cut the cable about 8" to 10" (200 to 250 mm) longer than necessary. Feed the end of the cable through the center of the spring, around the first insulator on the control unit, and clamp the cable using the cable clamp supplied with the control unit. See **Figure 52**.
10. Install the wire form on the control unit insulators. Be sure the guard snaps into the retainers molded into the insulators. See **Figure 52**. At the control unit, after clamping the cable to the spring, cut the cable about 8" to 10" (200 to 250 mm) longer than necessary. Feed the end of the cable through the center of the spring, around the first insulator on the control unit, and clamp the cable using the cable clamp supplied with the control unit. See **Figure 52**.
11. Anti-Roost Installation at the Control Unit

Clamp with Anti-Roost Bracket and Insulator

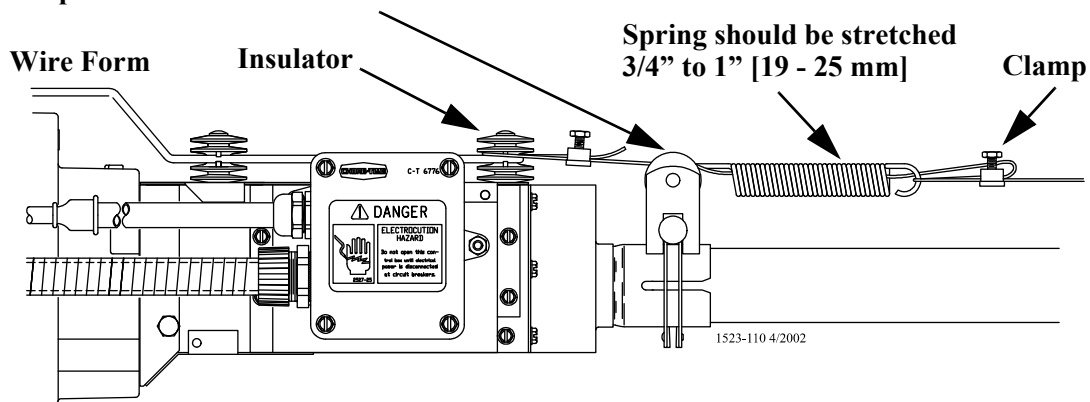

Figure 52. Cable hook up at Power Unit.

12. Install the Poultry Trainer or Line Charger, as shown in **Figure 53 or 54**.
 The Poultry Trainer is used to power all Anti-Roost lines in a house. See **Figure 53**.
 The Line Charger is used to power individual Anti-Roost lines in a house. See **Figure 54**.
 Route the charger wire (800 volt minimum) from the Poultry Trainer or Line Charger to the Anti-Roost system. Secure the Charger Wire to the Anti-Roost cable, using a cable clamp.
13. The anti-roost system must be on a separate electrical circuit, allowing the system to be disconnected by a switch near the door.
 Remember, the Anti-Roost System should be grounded through the poultry trainer.

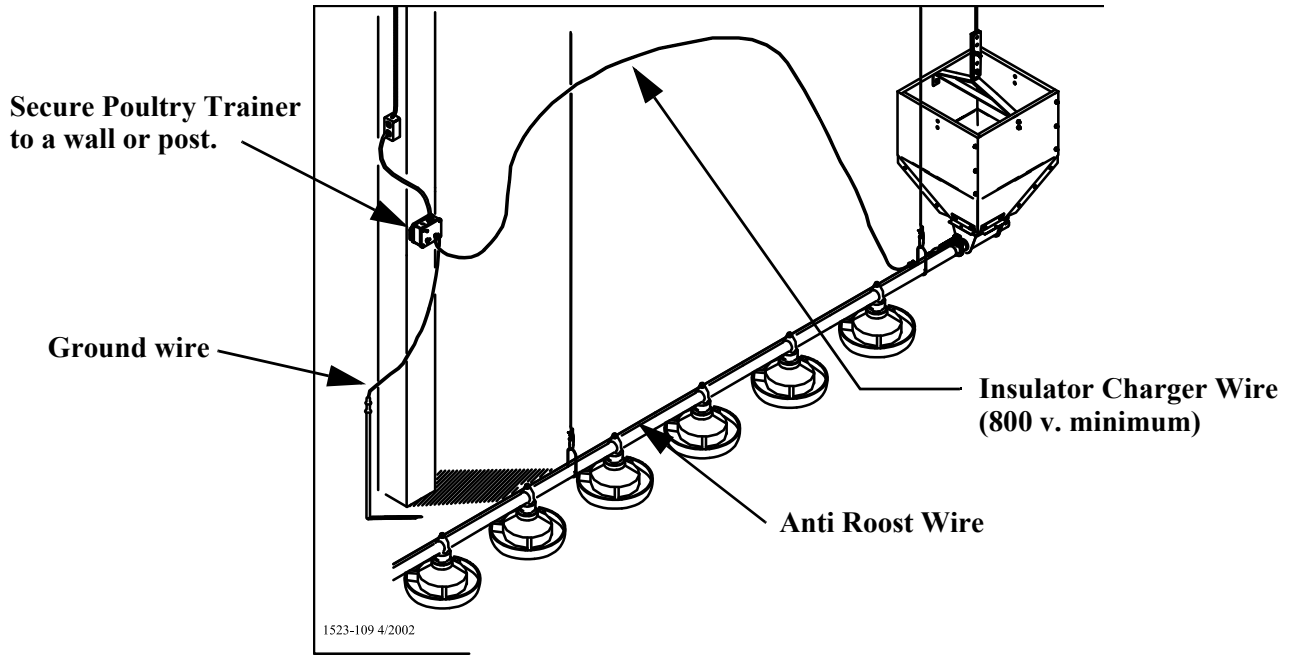

Figure 53. Anti-Roost Cable Mid-Line Connection

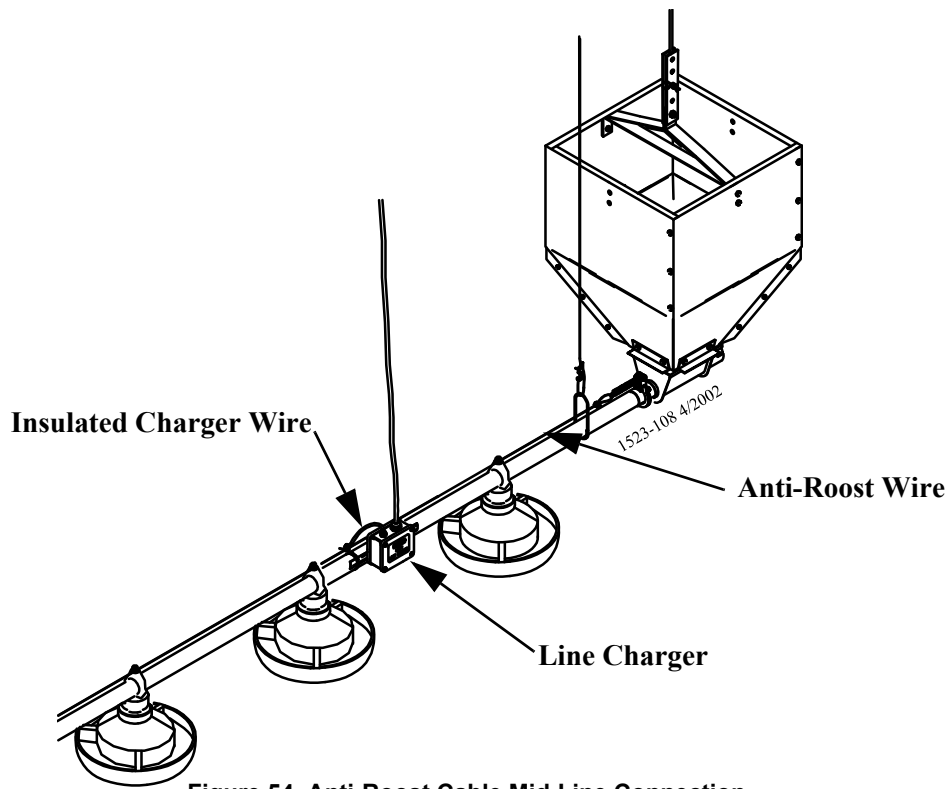
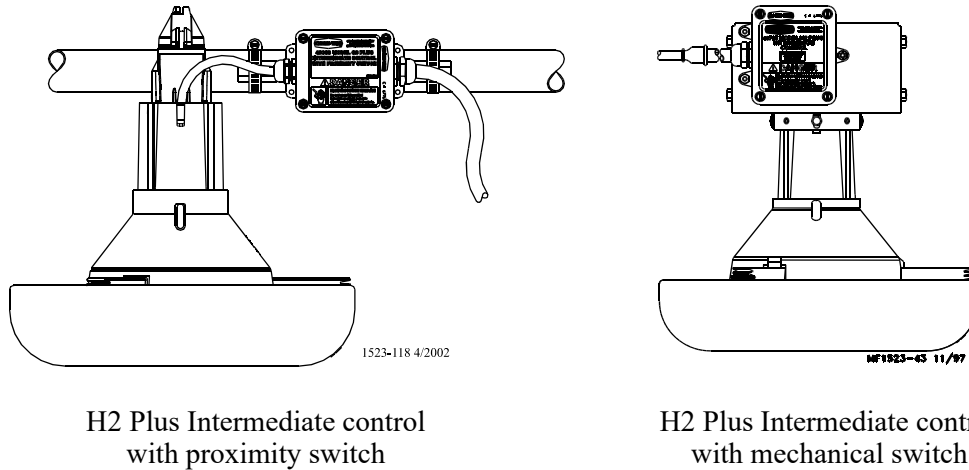

Figure 54. Anti-Roost Cable Mid-Line Connection

Intermediate Control

Intermediate Control Units are available for the Model H2 Plus Feeder. The Intermediate Controls are shown in **Figure 55**.



H2 Plus Intermediate control
with proximity switch

H2 Plus Intermediate control
with mechanical switch

Figure 55. Intermediate Control Units (Side Views)

The Intermediate Control makes it possible to operate the feeding system when birds are confined away from the End Control Unit. Chore-Time recommends placing the Intermediate Control Feeder at least 2 pans away from the curtain or partition. See **Figure 56**.

1. **New Feeder Lines:** Leave one feeder pan assembly off the feeder tube at the point where the Intermediate Control needs to be placed. The feeder line can be assembled and suspended before attaching the Intermediate Control; or the Intermediate Control may be attached to the feeder tube when the other pans are installed.

Existing Feeder Lines: Cut the Grill Support and remove the feeder pan at the location where the Intermediate Control will be installed.

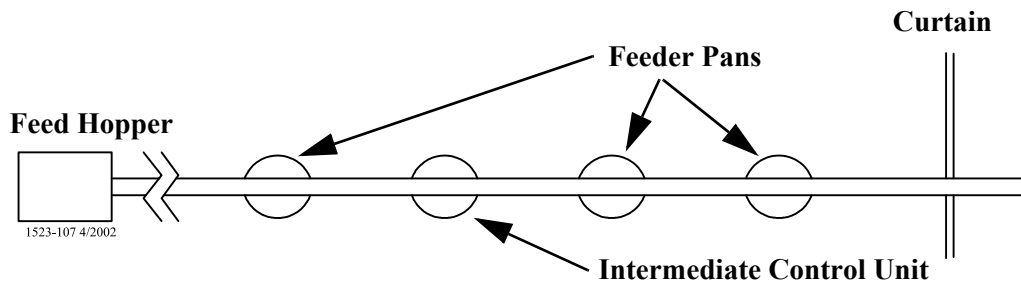
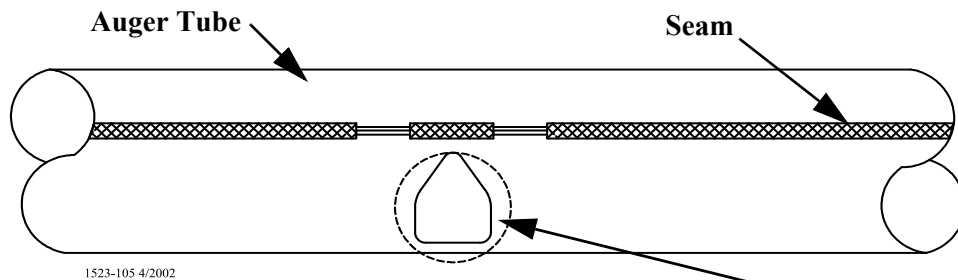

Figure 56. Intermediate Control Location Diagram (Top View)

2. If a Control Tube with enlarged holes is not used, enlarge the outlet hole for the Intermediate Control, plus (2) outlet holes in front of Intermediate Control.

See **Figure 57** for recommended size and placement. Use hacksaw and tin snips to enlarge hole size. Be sure there are no burrs inside the tube to catch the auger.



Use a unibit to enlarge outlet holes from 7/8" to 1" [2.22 - 2.54 mm] diameter.

Figure 57. Enlarging Outlet Holes (Side View)

Intermediate Control with Mechanical Switch Installation

Remove the two hex head screws on the control top.

Lift off the control top.

Cradle the feeder tube in the control housing. The feeder tube may have to be turned slightly to allow the pan to hang straight.

Clamp the control in place by inserting tabs on the control top into the slots on the control body. Install and tighten the two hex head screws previously removed.

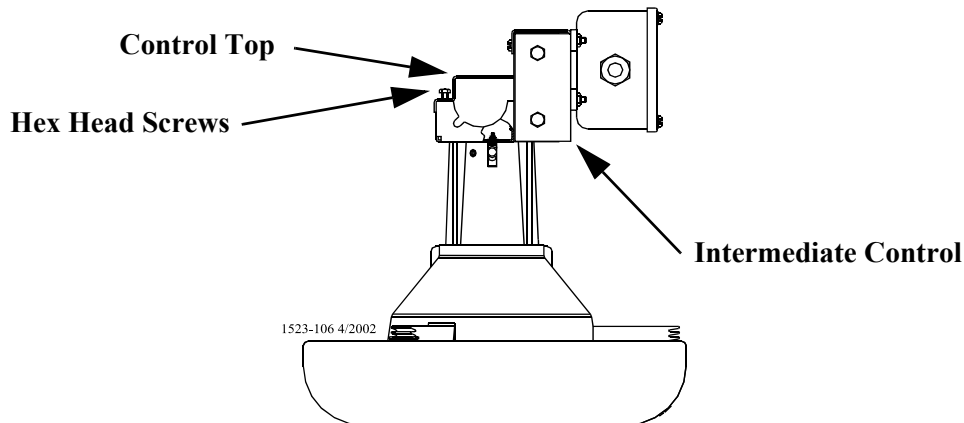

Figure 58. Intermediate Control Installation

Install a toggle switch, out of reach of the birds, to disconnect power to the Intermediate Control. This allows the Intermediate Control to serve as standard feeder when not used as a control feeder.

Wire the Intermediate Control as shown in the wiring diagram section of this manual.

Intermediate Control with Sensor Plus Switch Installation

Assemble the Mid-Line Control to the Feeder Tube, as shown in **Figure 59**.

Attach the Switch Box Assembly to the Feeder Tube with Hose Clamps as shown in **Figure 59**.

Install a toggle switch, out of reach of the birds, to disconnect power to the Mid-Line Control. This allows the Mid-Line Control to serve as a standard feeder when not used as a control feeder.

Wire the Mid-Line Control as shown in the wiring diagram section of this manual.

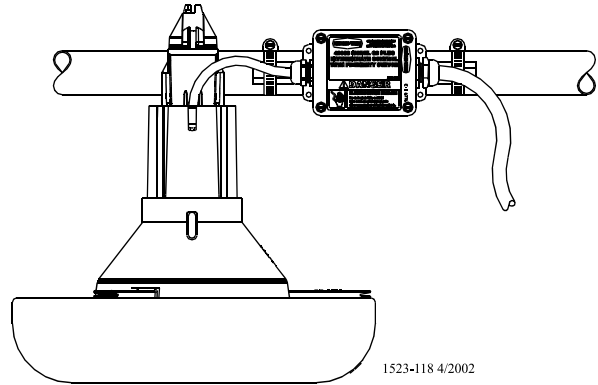

Figure 59. Intermediate Control Installation

MODEL H2™ PLUS

FEEDER MANAGEMENT AND OPERATION

This section provides you with valuable information concerning feeder operation and management. It is important that you read this information and understand how the feeding system was designed to operate. Once you become familiar with the system, you may *custom operate* it to fit your individual needs.

Initial Start-up of the Feeding System

The feeding system should be operated prior to birds being housed to make sure the installation is correct, the switches function properly, and to fill the feeder lines with feed.

There are typical layouts for the feeding system that was determined prior to the installation. Normally if the building is 400' (122 m.) or over, a center house hopper set-up is used (figure 2). For buildings under 400' (122 m), the hopper is placed at one end and the control pan/power unit at the other (figure 1). It is common practice to use partial house brooding during the early days of poultry production. For buildings that have the feeder split in the center (center hopper set-up), normally only the feeders that are in the brood area are used during brood time. For buildings that have the hopper at one end, brooding can be done on the motor end or an optional intermediate control pan(s) can be placed on the feeder line.

The feeder tubes and auger are supplied from the factory with a protective oil coating that will cause the system to deliver feed at a reduced rate. The oil coating will also create a larger load on the power unit (motor) until the system has been initially purged with feed, and becomes broken in.

To operate

1. Lower feeder lines so the feed pans are resting on the floor. Although the major weight of the feeder lines will be on the floor, do not remove all the weight from the suspension system and allow the cables to become slack.
2. Raise the feeder cones to open the feed flood windows by using the feed line winch.
3. Apply power to the feeder lines to check the operation. Allow to operate empty for 1-2 minutes.

NOTE: For feeder lines that have intermediate controls, the recommended bypass switches are wired into the system for selection of partial or full house control. Select the switch so the intermediate control is functional. As the feeder operates, the feed will stop at the intermediate control pan.

4. With the shut-off slide on the feed bin boot closed, energize the Flex-Auger® Fill System. After operation of approximately 1-2 minutes, open the boot slide ½ way to allow feed to be conveyed to the feeders.
5. Once feed begins to be dispensed into the feed hopper(s), manually shut-off the fill system.
6. Apply power again to the feeder lines. Operate the fill system manually to dispense approximately 50 lb. (23 kg.) increments of feed into the feed hopper(s). Allow the feed hopper to become empty for 30 seconds between each increment to reduce load on the feeder motor. Continue this procedure until feed has been dispensed to all the feeder pans. When the feed reaches the control pan, the feeder line will be shut-off.
7. Once the feeder lines have been initially filled with feed, manually dispensing feed in 50 lb. (23kg) increments will no longer be necessary. The shut-off slide on the Flex-Auger® Fill System boot may be completely opened. Refer to the Flex-Auger Fill System Operator's Manual for information when multiple feed bins are used.

General Operation of the MODEL H2™PLUS Feeder

These recommendations are the guideline to aid producers with the use of the feeding system. With experience a feeding program will be developed to enhance the feeding systems performance. Several factors such as feed content, type of birds, climate, lighting programs, and etc., may dictate change from these recommendations.

The MODEL H2™PLUS feeder has feed flood windows, which allows the feeder pan, to be filled with a high level of feed for the brooding of young birds. Start young birds with the feeder line lowered so the feed pans are resting on the floor and open the feed flood windows using the feed line winch. Although the major weight of the feeder lines will be on the floor, do not remove all the weight from the suspension system and allow the cables to become slack.

It is advisable to provide supplemental feed during the first few days for the young birds. This is especially true when partial house brooding is used (refer to Figure 1). Supplemental feeders, such as the CHORE-TIME® E-Z START® Chick Feeder, provide extra feeding space and access to the feed.

With the feeders lowered to the floor and the feed flood windows open, the operation of the feeder will allow a high level of feed to be placed into the feed pans making it easy for the birds to find feed, adapt to the feeder, and begin to eat.

Do not operate the feeding system on automatic (full demand feed) when the feed windows are open (cones raised). Chore-Time recommends having the feed windows full open for up to the first 14 days for broilers and up to 21 days for turkeys. The feeders will need to be operated at least 2 times a day for the first 5 days, and thereafter, 3 times a day or more as needed, while the windows are open. If it is not possible to operate the feeder manually 1-3 times a day during the brood time (windows open), then a time clock should be utilized to limit the number of times and length of time the feeder can operate. Failure to do one of the above will create the possibility of an excessive high feed level in the feed pans enabling the birds to waste feed.

DO NOT OPERATE THE FEEDING SYSTEM ON AUTOMATIC (FULL FEED) WHEN THE FEED WINDOWS ARE OPEN.

As the birds grow and become acclimated to the feeder pans, the feeder cones can be progressively lowered to the grow-out position over a period of days to reduce the feed level in the feed pans. Before lowering the feed cones, it is recommended to allow the birds to eat the feed level down below the feed cone. This will ease the process of the feed cones being lowered properly.

For broilers, once the feed cones have been lowered to the grow-out position, the suspension system should be used to raise the feeder(s) line to the recommended pan height.

For turkeys, many producers prefer to begin raising the feeder lines at approximately 2 weeks of age prior to completely closing off the feed windows to the grow-up position. This method allows the bird to have a high level of feed and reduces to ability of the birds to waste feed.

When the feeder is raised to just clear the litter, there may be a few places where the litter is lower and the pans seem too high. Do not be concerned as the birds will level the litter and at this young bird age, there will be sufficient feeder space.

The correct feeder pan height adjustment is the area where the bird's neck meets its breast is equal to the top edge of the feeder pan.

The feeder setting should be placed in #2 position for broilers and setting #4 with turkeys for most applications.

The adjustment settings are easy to understand and change by placing the lip of the feed pan on the tabs of the feeder support. The settings are based by the pan lip edge resting on one of the seven tabs. See **Figure 22 on Page 14.**

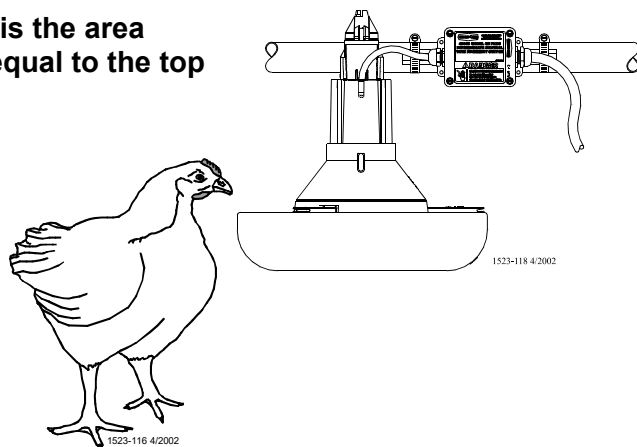

Feed texture and consistency, type of bird, or other variables may make it necessary to change to another feed setting position. The combination of proper pan height, feeder setting, and feeder operation will result in optimum feeder performance. The operator will learn what performs best for his/her situation with experience.

End Control and Intermediate Control Pans

At installation time, the end control pan of the feeder was placed to be 10 feet (3 m) from the end of the building to allow the birds access around the end of the feeder line. It is important that the feed setting of the end control pan be the same as the rest of the feeder pans so the birds can activate the feeder.

The intermediate control is placed on the feeder line when partial house brooding is desired. It is important that the intermediate control be installed at least 2 feeder pans away from the curtain or partition so the birds will activate the feeder line. The feed setting for the intermediate control should be the same as the rest of the feeder pans on the feeder line. A toggle switch or disconnect is used to bypass the power to the intermediate control. This allows the intermediate control to serve as a standard feeder after brooding. The feeder can be changed from full house operation to partial house brooding with the activation of the switch.

Controlling the Feeders (optional equipment)

A time clock control is used with the feeding system to reduce excessive feeder operation time and limit feed wastage. The basic use of a time clock control is to allow periods of time during the day for the birds to reduce the feed level in the feeder pans and to limit the possibility of the birds creating a high feed level and wasting feed. This is not to be confused with lighting programs that have become very common place. If lighting or intermittent lighting programs are to be used, the use of the time clock control will be limited to just the light period. **Caution should be used to not restrict the feed from the birds during the light period.** Experience with the feeding system will determine how the time clock control is used.

The MODEL H2™ PLUS Feeding System may be controlled by the #34385 Control Panel or the #34574 Time Clock Control. Refer to the instructions supplied with each control for information.

Electro-guard Operation

The electro-guard chargers should be wired on a separate electrical circuit so the anti-roost system can be shut off using a switch next to the entrance door when someone enters the building. Birds are less likely to become wild and flighty if the anti-roost is off when people are in the building.

Maintenance

Floor Feeding System Maintenance

The Model H2 Plus Feeders require minimum maintenance. However, a routine periodic inspection of the equipment will prevent unnecessary problems.

Maintenance should be done by a qualified technician.

ALWAYS DISCONNECT POWER TO THE SYSTEM WHEN SERVICING OR MAINTAINING THE EQUIPMENT. FAILURE TO DISCONNECT POWER MAY CAUSE INJURY OR DEATH.

Gear Head Maintenance

Refer to **Figure 54**.

Check the oil level in the gear heads at installation and every 6 months. The Pipe Plug, on the side of the gear head, indicates proper oil level. Add SAE 40W oil when necessary.

The oil in the gearheads should be replaced every 12 months with new SAE 40W oil

- A. Remove the bottom Pipe Plug to drain the oil. Discard used oil in accordance with local and national codes.
- B. Wipe any debris off the magnet on the bottom Pipe Plug and reinstall. Remove the side Pipe Plug and (top) Vent Plug.
- C. Set the power unit in the horizontal position.
- D. 2-Stage Gearheads: Add approximately 9 oz. (266 ml) of SAE 40W oil through top hole. This should be just enough oil to reach the side Pipe Plug.
3-Stage Gearheads (3261-9, 3261-12, 3261-14): Add approximately 13 oz. (384 ml) of SAE 40W oil through top hole. This should be just enough oil to reach the side Pipe Plug.
- E. Install the side Pipe Plug and (top) Vent Plug.

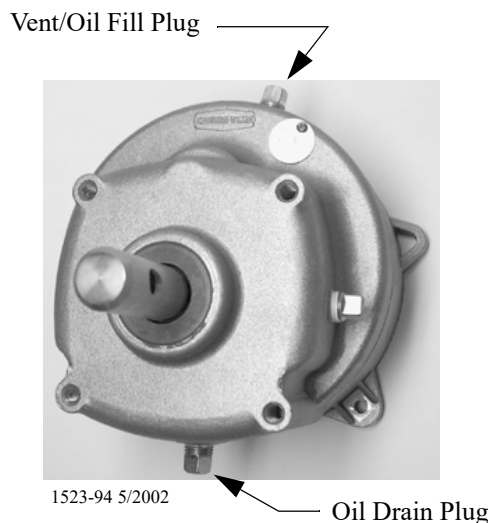

- Check the oil level in the gear head at installation.
- Check the oil level every 6 months.
- Check the oil level at the side plug. If oil is needed, use SAE 40W oil.
- Oil capacity for the two stage gear head is 9 oz. [266 ml].
- Oil capacity for the three stage gear head is 13 oz. [384 ml].
- The oil should be changed every 12 months.

Figure 60. Gearhead Maintenance

Check equipment for loose hardware after the first flock and then every 6 months--including the Anchor Block. Tighten if necessary.

Mechanical Switch Adjustment Procedure

Refer to **Figure 61**.

- A. Turn the adjustment nut counter-clockwise until the switch clicks.
- B. Turn the adjustment nut clockwise until the switch clicks.
- C. Turn the adjustment nut counter-clockwise 3/4 turn.

Adjustment Nut



SENSOR PLUS Sensor Switch Time Delay Adjustment

Refer to **Figure 62**.

The SENSOR PLUS Pan Half Round Sensor Switch is adjusted at the factory to a sensitivity of .25" [6 mm].

To adjust the Time Delay:

- For less time — turn Time Delay Adjusting Screw (item 5) counter-clockwise (Light blinks fast)
- For more time — turn Time Delay Adjusting Screw (item 5) clockwise (Light blinks slow)

Time Delay Adjustment

Light indicates time range;
fast blink = short delay
slow blink = long delay

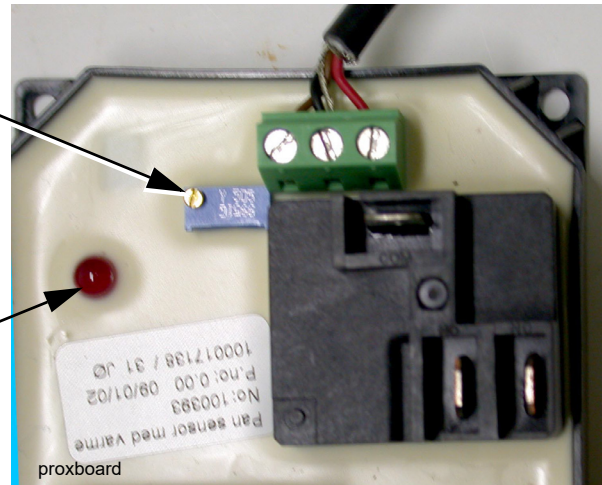

Figure 62. Adjusting the SENSOR PLUS Proximity Switch

Feeder Line Maintenance

Keep anti-roost cables tightly stretched. This increases the effectiveness of the electro-guard anti-roost system and keep the pans from being tilted when birds push against them.

Remove all feed from the feeder when there are no birds in the house and when the building is washed and disinfected.

Turn the feeders off prior to removing the birds from the house. This will allow them to clean the feed out of the pans.

If the system is not to be used for an extended period of time, remove all the feed from the feeder lines and feeder pans.

Disconnect power to the system to prevent accidentally starting the system.

If the system must be disassembled, extreme caution must be used to prevent injury from springing auger. Refer to **Figure 39**.

1. Disconnect power to the entire system.
2. Loosen the Tube Clamp on the bearing at the hopper end of the system. Remove the Tube Clamp and Bearing Retainer.
3. Pull the Anchor and Bearing Assembly and approximately 18" [45 cm] of auger out of the boot.

CAUTION: Stand clear...the auger may spring back into the tube.

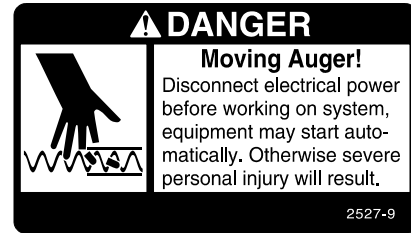

4. Place a clamp or locking pliers securely on the auger to prevent it from springing back into the auger boot.
5. Loosen the setscrews in the bearing assembly shaft and remove the Anchor and Bearing Assembly from the auger.

To reinstall the Anchor and Bearing Assembly:

1. Insert the Anchor Assembly into the auger until it touches the washer at the back of the anchor. Tighten the setscrews in the center of the anchor until they touch the auger, then tighten a maximum of 1/2 turn. See **Figure 63**.
2. **Carefully** remove the locking pliers while holding onto the Anchor and Bearing Assembly and auger securely.



Figure 63. Auger and Anchor Bearing Connection

Slowly ease the auger back into the tube. Use caution. If the auger is allowed to spring back, the bearing race may crack. Install the Bearing Retainer and fasten with a tube clamp. Keep the Bearing Retainer flush with the end of the anchor for safety.

Power Lift Winch Maintenance

Refer to **Figure 64**.

Grease the winch every 6 months with 1 to 2 shots of common industrial or automotive grease. **DO NOT OVER GREASE THE WINCH.**

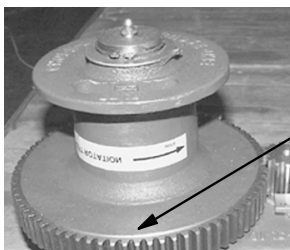

Grease the Power Lift Winch every 6 months with 1 to 2 shots of common industrial or automotive grease **DO NOT OVER GREASE THE POWER LIFT WINCH**

1660-24 6/2001

Figure 64. Maintenance to the Power Lift Winch

Trouble Shooting the Floor Feeding System

ALWAYS DISCONNECT POWER TO THE SYSTEM WHEN SERVICING OR MAINTAINING THE EQUIPMENT. FAILURE TO DISCONNECT POWER MAY CAUSE INJURY OR DEATH.

Service and maintenance work should be done by a qualified technician only.

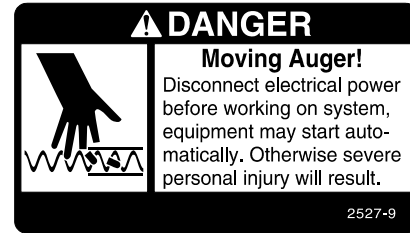
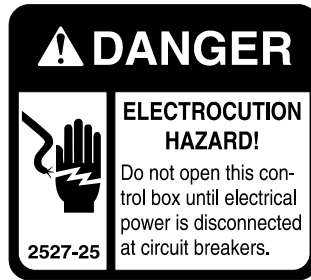

Problem	Possible Cause	Corrective Action
None of the feeder lines will operate	No power supplied to equipment	Replace burned fuses or reset circuit breaker Make sure voltage required is supplied
	Time Clock or relay defective	Replace Time Clock or relay
	Time Clock improperly programmed	Refer to Programming the Time Clock section and reprogram the Time Clock
Feeder line will not operate	Power unit cord not plugged in sufficiently to make contact	Check motor cord plug at control unit and control unit plug at outlet for connection
	Motor cord wires are broken at plug or where cord enters motor	Check cord for continuity Replace if defective
	Power Units thermal overload tripped	Push motor overload reset button to reset
	Control unit switch defective or out of adjustment	Adjust switch according to the Switch Adjustment Procedure in the maintenance section
Motor overloads frequently	Oil on new auger loads motor excessively when feed is carried for first time	Polish auger by running 50 lb (20 kg) increments of feed out to pans
	Inadequate power reaching motors	Check line voltage at the motors Check starting current draw at motors Wiring of adequate size is essential to feeder operation
	Object caught in the auger; motor runs, stalls, then auger spins in reverse	Check hopper boot, control unit and pan outlet holes for foreign objects Remove obstruction
Auger runs erratically	Frozen or cracked bearing at boot anchor	Replace bearing Slowly ease auger back into tube Be careful not to damage the bearing when reinserting the auger
	Insufficient stretch in auger	Shorten the auger
	Obstruction in the auger	Remove obstruction
Auger tube or boot wears out rapidly (Noisy feeder operation)	Auger is bent or kinked	Repair or replace damaged auger
	End of auger is riding up on anchor weldment	Auger must not be positioned over weld on anchor Check for bent or damaged auger
Oil leaking out of seals on power unit	Gearhead vent plug not installed	Replace plastic shipping plug with vent plug
	Defective gear head seal	Replace seal
Not enough feed supplied to the feeder pans	Insufficient time programmed on the time clock	Add more operating time to feeding period
	Feeder line control unit switch out of adjustment	Adjust switch according to the Switch Adjustment Procedure in the maintenance section

Wiring Diagrams

SENSOR PLUS Wiring Diagram

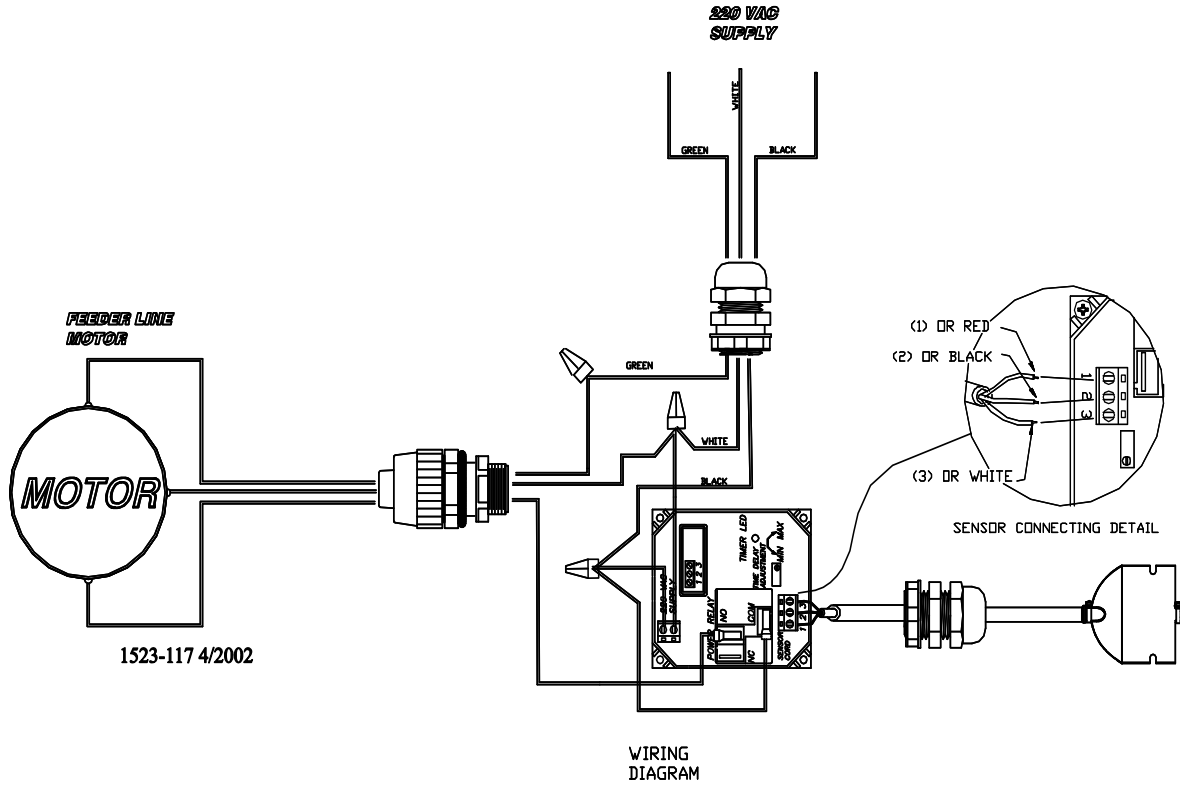

SENSOR PLUS Control Wiring Diagram

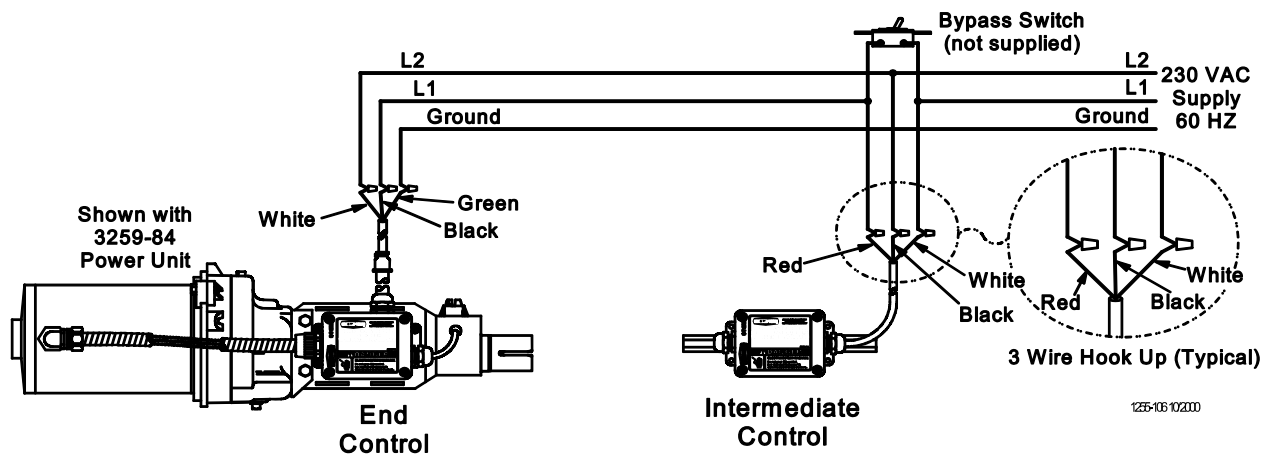

Mechanical Switch Single Phase Wiring Diagram

FROM DISCONNECT OR
CONTROL DISCONNECT
220/230 VOLTS 50/60 HZ

SINGLE PHASE WIRING DIAGRAM

FEEDER LINE MOTOR
220/230 VOLTS 50/60 HZ
SINGLE PHASE

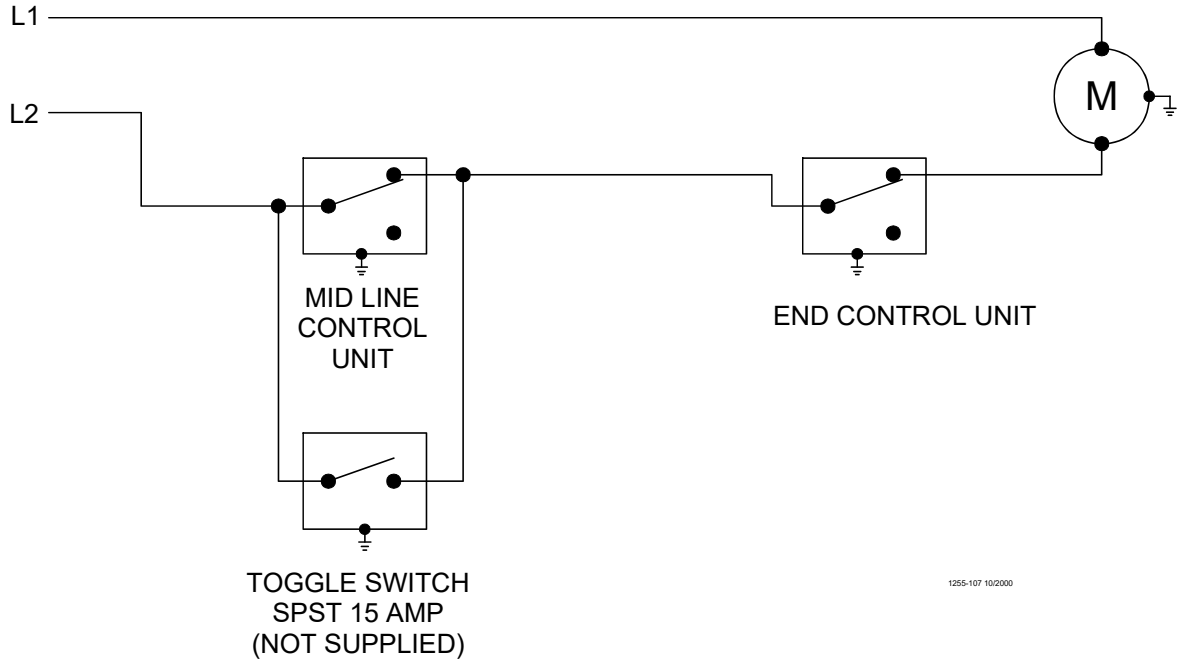

1255-107 10/2000

Mechanical Switch Single Phase Wiring Diagram (with Motor Starter)

SINGLE PHASE

FROM DISCONNECT OR
CONTROL DISCONNECT
220/230 VOLTS 50/60 HZ

TO ADDITIONAL
FEEDER LINES

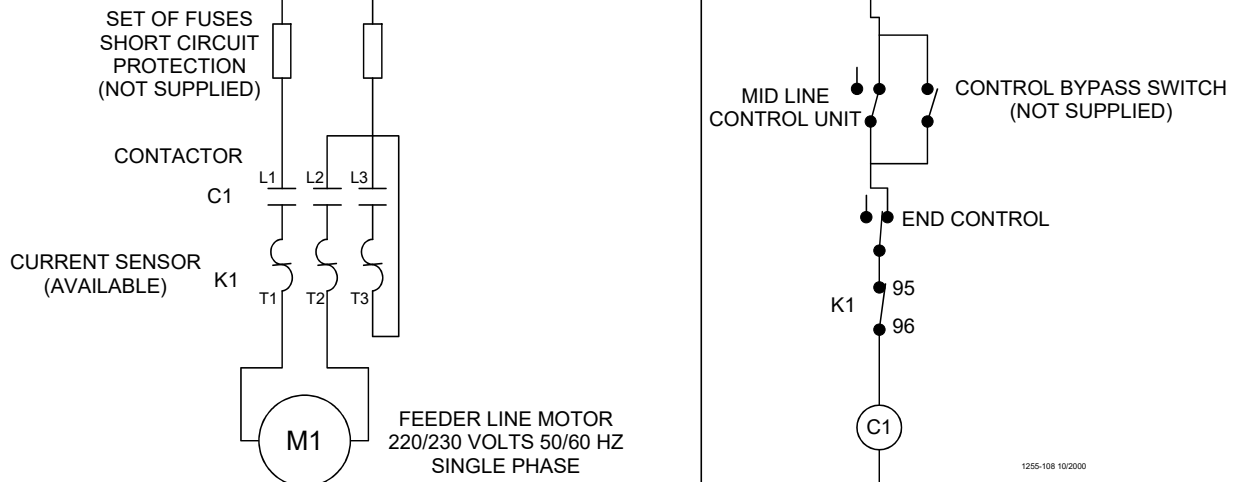

1255-108 10/2000

Mechanical Switch Three Phase Wiring Diagram: 220 V.

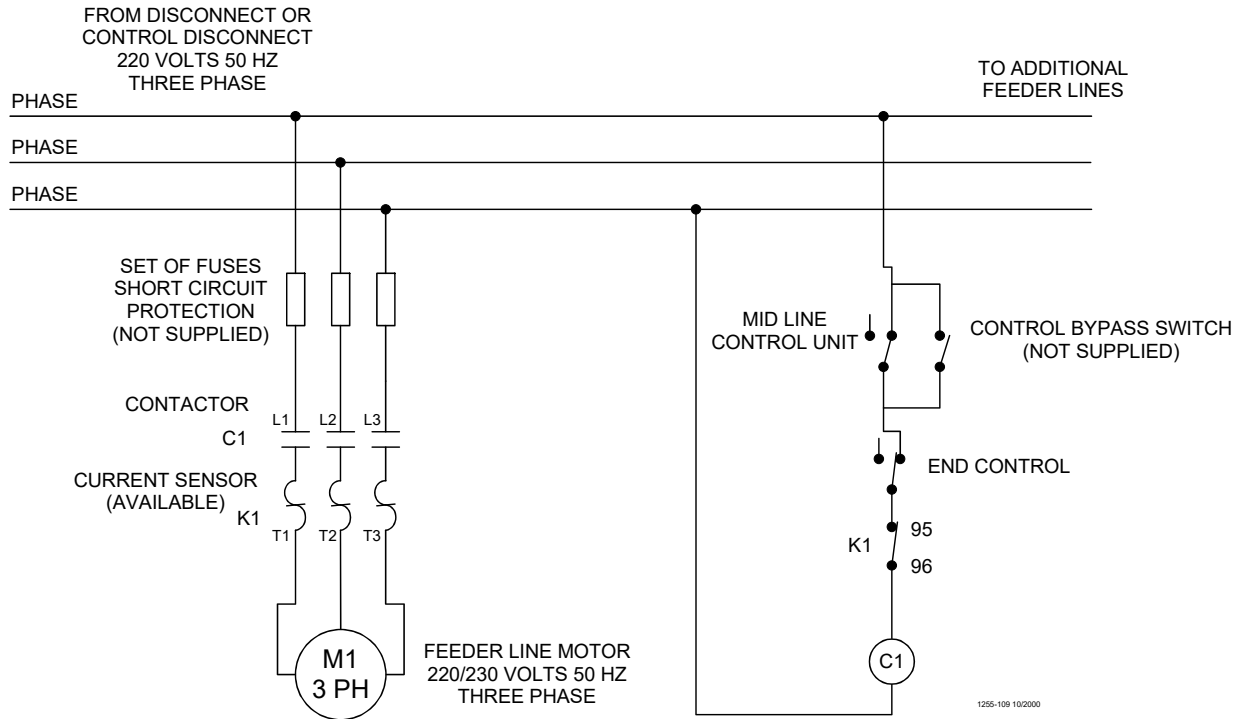

Mechanical Switch Three Phase Wiring Diagram: 380/415 V.

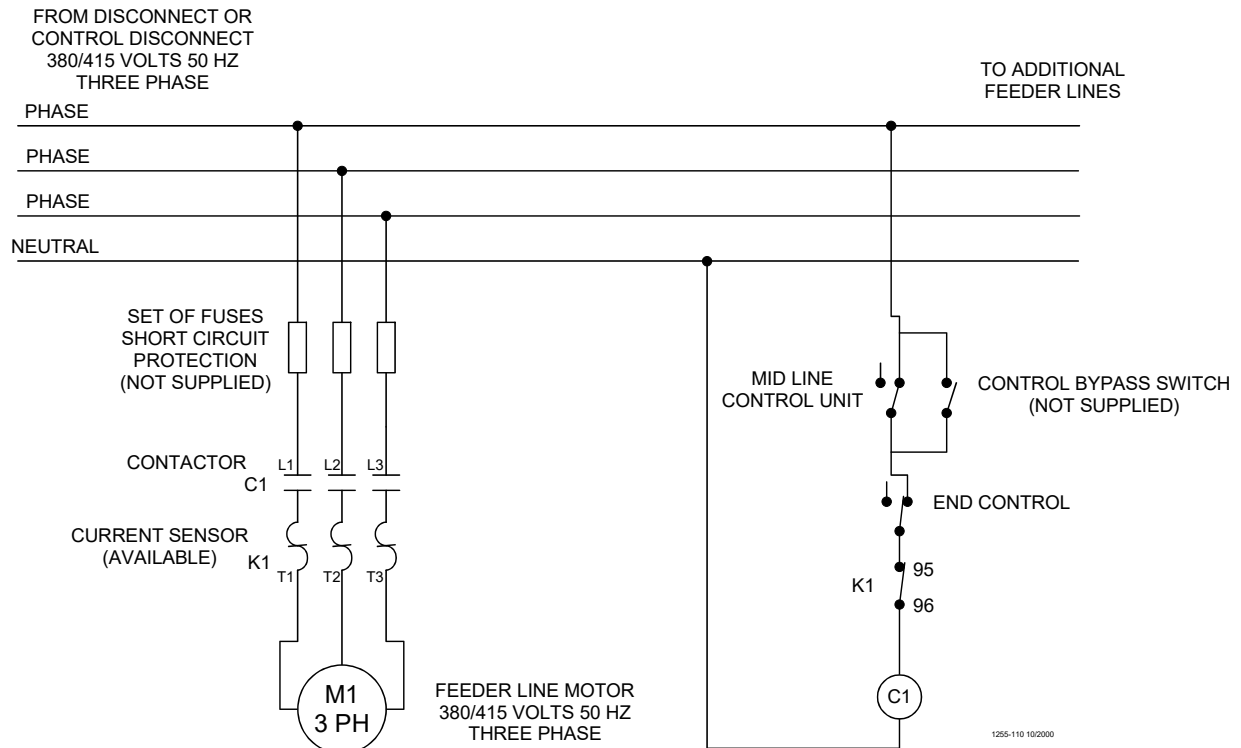

Parts Listing

100# Hopper Components

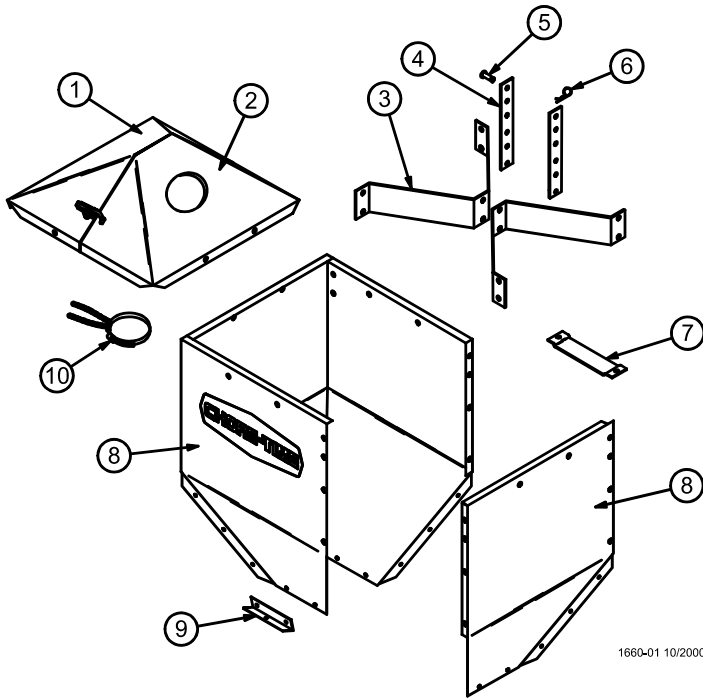

Item	Description	Part No.
1*	Hopper Cover (optional)	28206
2	Tube Support Assembly	14367
	Clamp	13948
	Chain	2128-1
3	Hopper Side	2680
4	Boot Hanger	2671
5	Hanger Bracket Assembly	2681
6	Adjustment Bracket	2706
7	Hair Pin	2664
8	Clevis Pin, 5/16 x 1"	2797-1

*Hopper Cover not included. Must be ordered separately.

The 200# Hopper Assembly may be ordered under Part No. 7941. Hopper Cover must be ordered separately.

200# Hopper Components

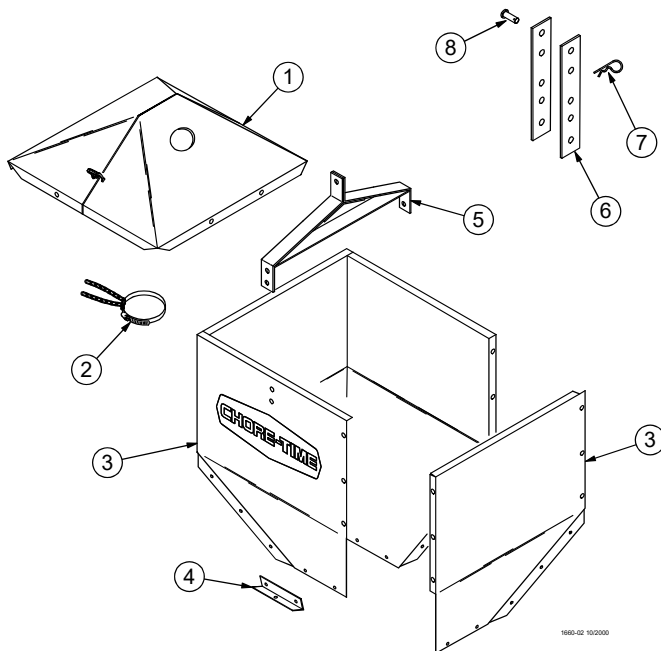

Key	Description	Part No.
1*	Hopper Cover (w/o hole)	28211
2*	Hopper Cover (w/ hole)	28212
3	Hopper Hanger	28165
4	Adjustment Bracket	2706
5	Clevis Pin, 5/16" x 1"	2797-1
6	Hair Pin	2664
7	H.L.C Mounting Bracket	26287
8	Hopper Side (w/ hole)	24241
9	Boot Hanger	28168
10	Tube Support Assembly	14367

*These components may be ordered as an assembly under Part No. 28210.

The 100# Hopper Assembly may be ordered under Part No. 28220.

The 100# Hopper Assembly, including the Cover, may be ordered under Part No. 28240.

Hopper Boot Suspension Bracket (optional)

Single Boot Hopper Support Kit: Part No. 34851

Twin Boot Hopper Support Kit: Part No. 38241

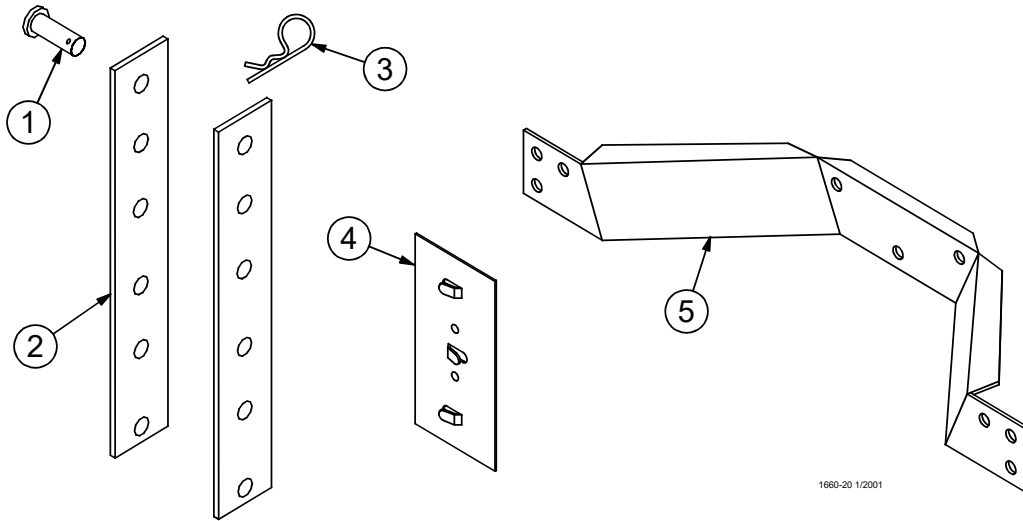

1660-20 1/2001

Item	Description	Part No. Single Boot Kit	Part No. Twin Boot Kit
1	Clevis Pin, 5/16" x 1"	2797-1	2797-1
2	Adjustment Bracket	2706	2706
3	Hair Pin	2664	2664
4	Cable Guide	34573	34573
5	Hopper Mount Bracket	34589	38242

Single Boot Components:

Part No. 6822

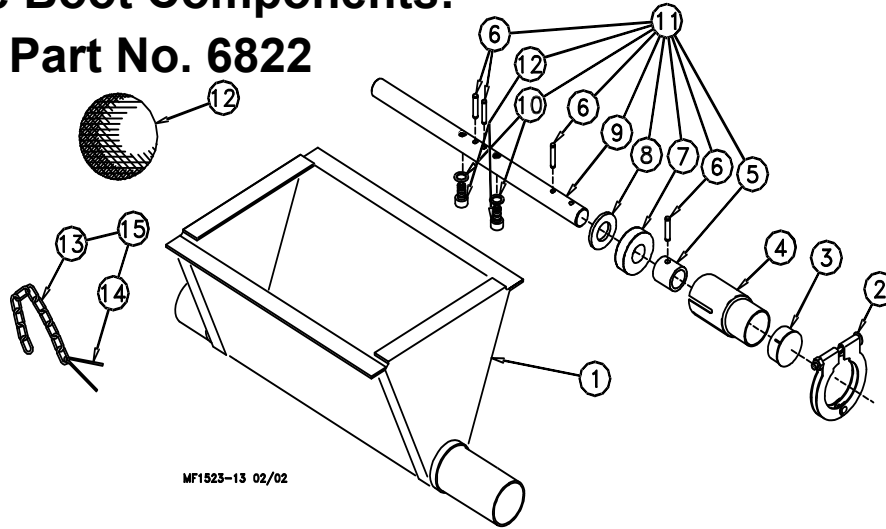

MF1523-13 02/02

Item	Description	Part No.
1	Boot Weldment	3760
2	Tube Clamp	24063
3	Cap	29373
4	Outlet Tube	4556
5	Sleeve	5648
6	3/16 x 1" Pin	2960-1
7	Bearing	2689
8	Washer	2955-14
--	Danger Decal	2527-9

Item	Description	Part No.
9	Anchor	38540
10	5/16-18x7/8" Sock Hd Screw	47867
11	Anchor and Bearing Ass'y	39372
12	Cannonball	3531
13	Chain	2128-1
14	Cotter Pin	1639
15	Latch Pin Ass'y	2683
16	Washer	2955-58

Twin Boot Components: Part No.

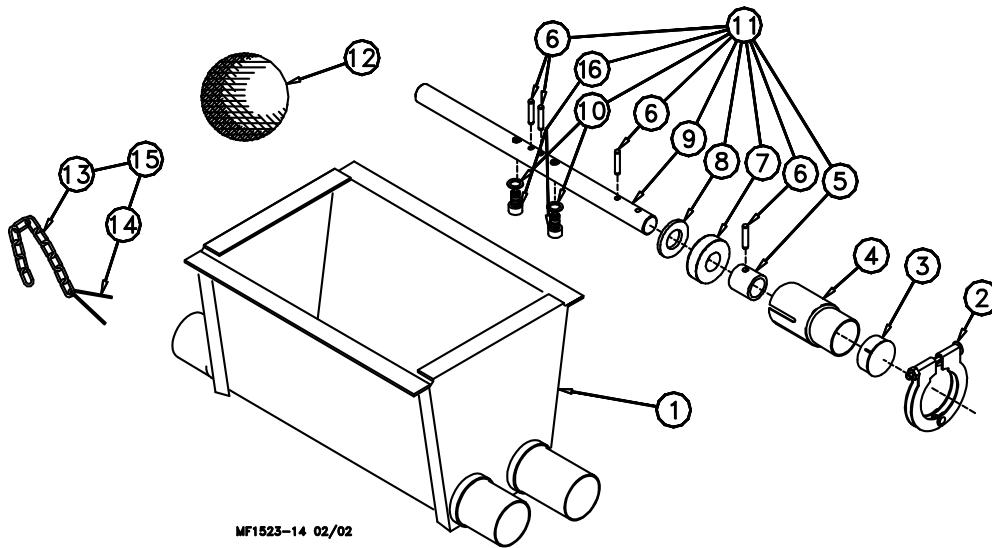

MF1523-14 02/02

Item	Description	Part No.
1	Boot Weldment	3760
2	Tube Clamp	24063
3	Cap	29373
4	Outlet Tube	4556
5	Sleeve	5648
6	3/16 x 1" Pin	2960-1
7	Bearing	2689
8	Washer	2955-14
--	Danger Decal	2527-9

Item	Description	Part No.
9	Anchor	38540
10	5/16-18x7/8" Sock Hd Screw	47867
11	Anchor and Bearing Ass'y	39372
12	Cannonball	3531
13	Chain	2128-1
14	Cotter Pin	1639
15	Latch Pin Ass'y	2683
16	Washer	2955-58

Feeder Line Components

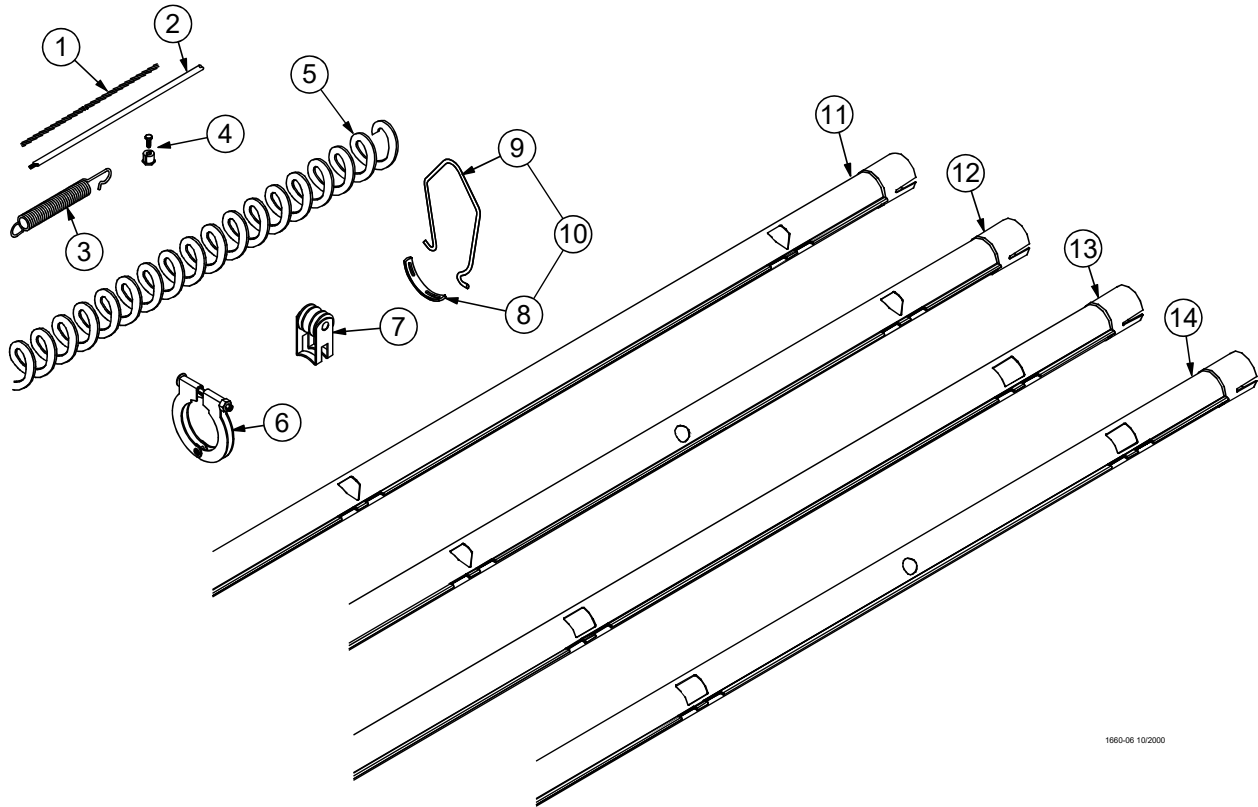

1660-06 10/2000

Item	Description	Part No.
1	1/16" Cable	1922
2	Charger Wire (165') Charger Wire (330')	28994-165 28994-330
3	Spring	7551
4	1/16" Cable Clamp	1826
5	Auger	6820-0
6	Tube Clamp	24063
7*	Anti-Roost Bracket	24060
8	Hanger Bracket	7297
9	Hanger Strap	7298
10	Hanger Kit	7299
11	Standard Feeder Tube —9', 5 Hole Tube —10', 3 Hole Tube —10', 4 Hole Tube —12', 3 Hole Tube —12', 4 Hole Tube —12', 5 Hole Tube	6854-1 6854-5 6854-4 6854-8 6854-7 6854-6
12	Standard Feeder Tube with Chick Holes —9', 8 Hole Tube —10', 8 Hole Tube —12', 8 Hole Tube —12', 10 Hole Tube	6854-15 6854-16 6854-17 6854-18
13	Control Feeder Tube —9', 4 Hole Tube —10', 4 Hole Tube —12', 4 Hole Tube —12', 5 Hole Tube	43006-1 43006-4 43006-7 43006-6
14	Control Feeder Tube with Chick Holes —9', 8 Hole Tube —10', 8 Hole Tube —12', 8 Hole Tube —12', 10 Hole Tube	43006-15 43006-16 43006-17 43006-18

Winch Kit: Part No. 46219

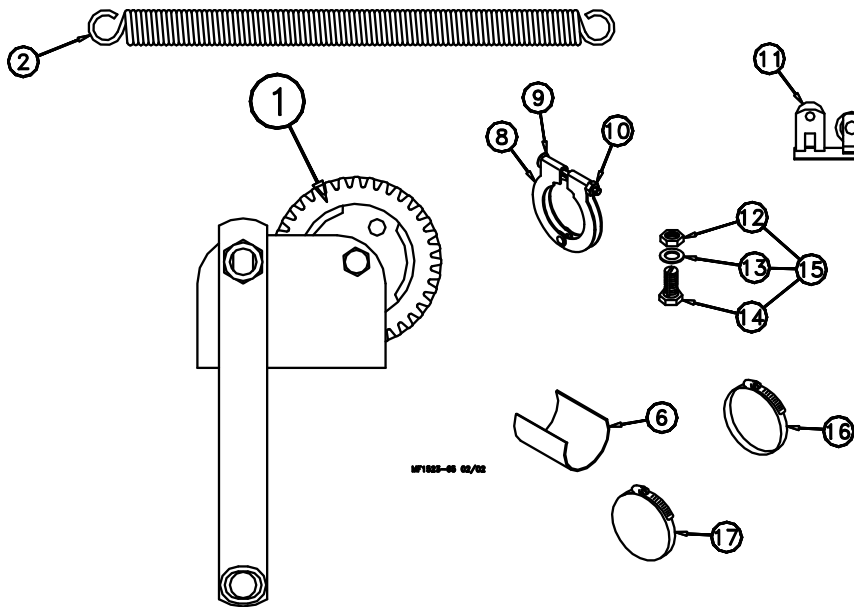

Key	Description	Part No.
1	Winch	43390
2	Spring	24302
6*	Tube Closure	9126
8*	Clamp Assembly	24062
9*	1/4-20 x 2-1/2" Carriage Bolt	7550-3
10*	1/4-20 Hex Flange Head Nut	24208
11*	Insulator Pulley Assembly	41479
12*	3/8-16 Hex Nut	1549
13*	Washer	4967
14*	3/8-16 Hex head Slotted Screw	6342
15*	Clamp Assembly	6478
16*	Band Clamp	3527
17*	Band Clamp	8643

* These items are included in a Hardware Package (Part No. 40107).

Poultry Trainers and Line Chargers

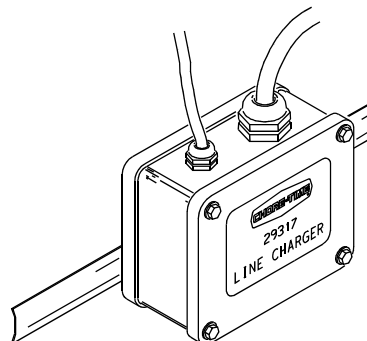
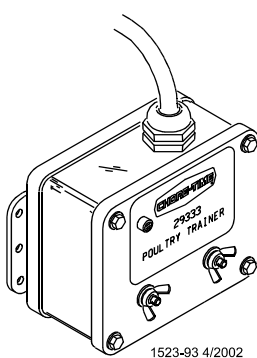

Description	Part No.
Poultry Trainer (110 V, 60 Hz.)	5303
Poultry Trainer (220 V, 50/60 Hz.)	5699
Line Charger (110 V, 60 Hz.)	5458
Line Charger (220 V, 50/60 Hz.)	5459

Model H2 Plus Feeder Assembly with Cords

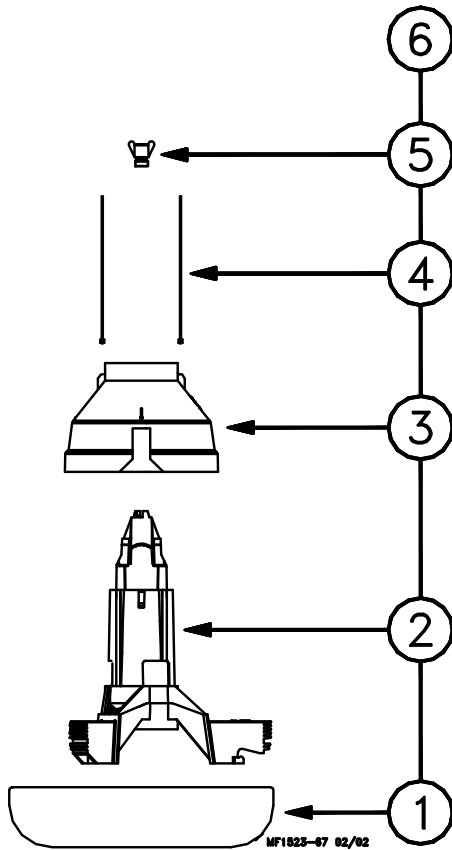

Item	Description	Part No.
1	H2 Feeder Pan	24901
2	H2 Plus Feeder Cone Support	38915
3	H2 Plus Feeder Cone - Silver H2 Plus Feeder Cone - Green	38914-1 38914-2
4	Cable Assembly	40105
5	Cable Clamp	13057
6	H2 Plus Pan Assembly - Silver H2 Plus Pan Assembly - Green	40109 40805

Model H2 Plus Feeder Assembly without Cords

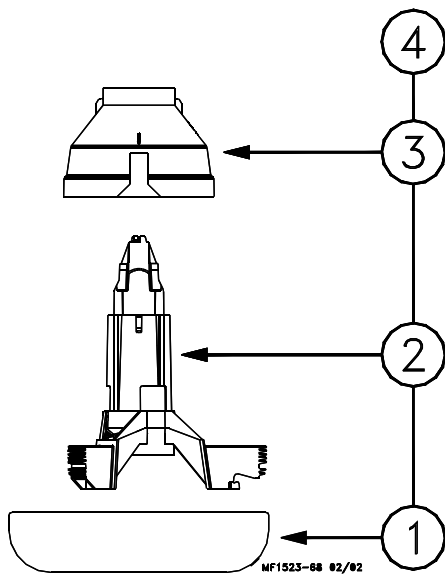

Item	Description	Part No.
1	H2 Feeder Pan	24901
2	H2 Plus Feeder Cone Support	38915
3	H2 Plus Feeder Cone - Silver H2 Plus Feeder Cone - Green	38914-1 38914-2
4	H2 Plus Pan Assembly - Silver H2 Plus Pan Assembly - Green	40106 40806

Removable Top Model H2 Plus Feeder Assembly with Cords

Item	Description	Part No.
1	H2 Feeder Pan	24901
2	Support Cone Bottom	40484
3	Removable Top	38603
4	H2 Plus Feeder Cone - Silver H2 Plus Feeder Cone - Green	38914-1 38914-2
5	Cable Assembly	40105
6	Cable Clamp	13057
7	H2 Plus Pan Assembly - Silver H2 Plus Pan Assembly - Green	40636 41722

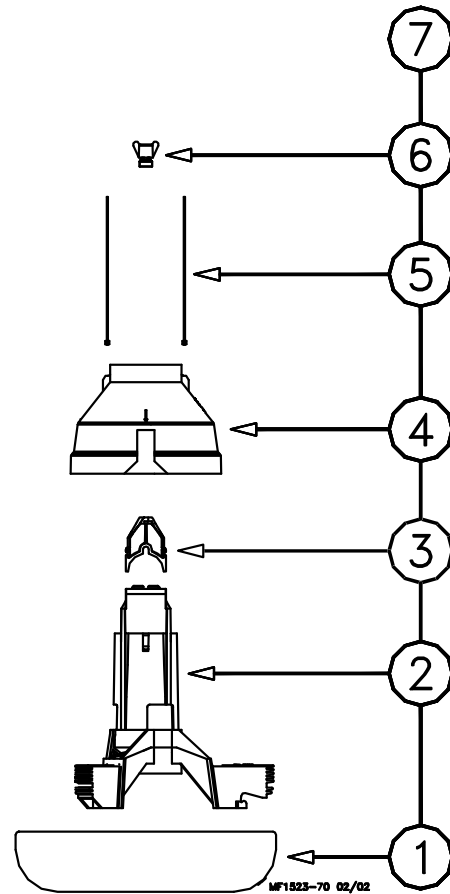

Removable Top Model H2 Plus Feeder Assembly without Cords

Item	Description	Part No.
1	H2 Feeder Pan	24901
2	Support Cone Bottom	40484
3	Removable Top	38603
4	H2 Plus Feeder Cone - Silver H2 Plus Feeder Cone - Green	38914-1 38914-2
5	H2 Plus Pan Assembly - Silver H2 Plus Pan Assembly - Green	40637 41723

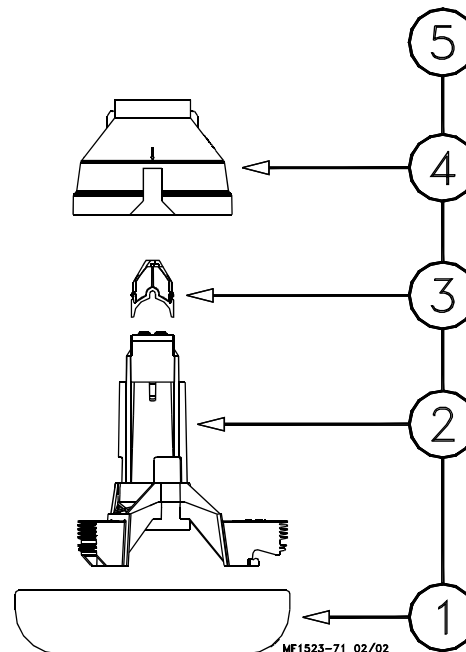

Power Unit Assemblies

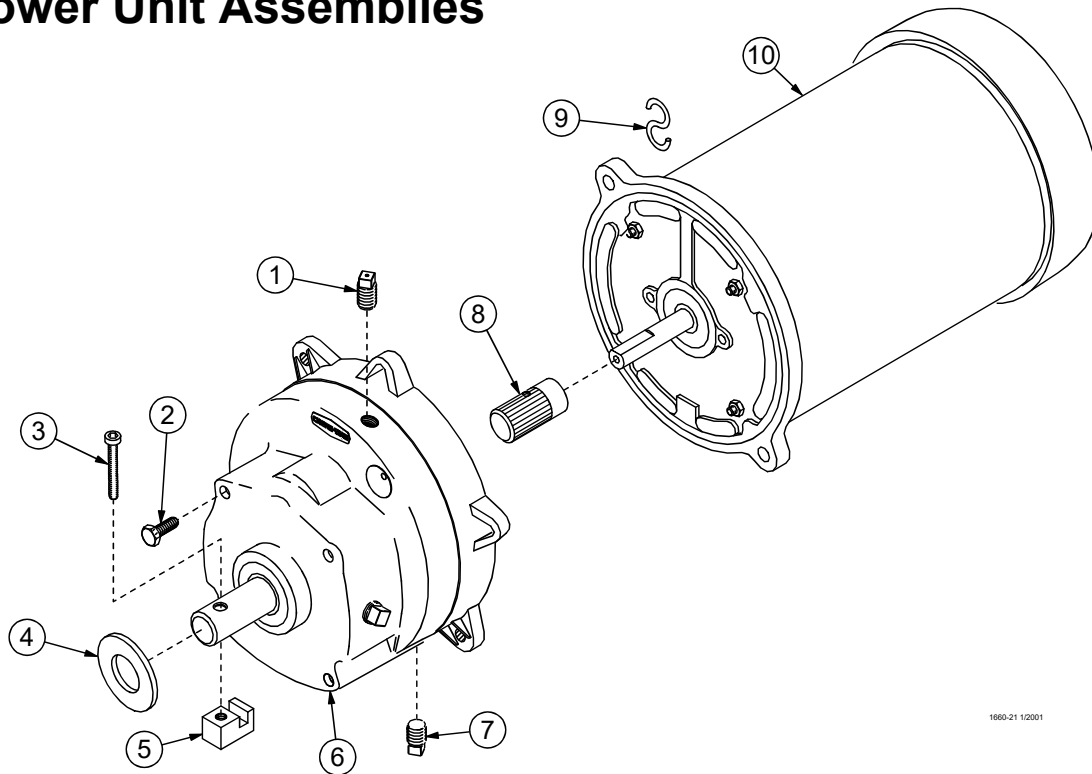

1660-21 1/2001

Item	Description	3259-8 Part No.	3259-25 Part No.	3259-84 Part No.	3259-85 Part No.	3259-98 Part No.	3259-100 Part No.	3259-128 Part No.
1	Vent Plug	3516	3516	3516	3516	3516	3516	3516
2	5/16-18x5/8 Hex Hd Screw	4412-1	4412-1	4412-1	4412-1	4412-1	4412-1	4412-1
3	1/4-20x1-1/2 Socket Hd Screw	5083-8	5083-8	5083-8	5083-8	5083-8	5083-8	5083-8
4	Flat Washer	1484	1484	1484	1484	1484	1484	1418
5	Driver Block	4642	4642	4642	4642	4642	4642	4642
6	Gearhead	3261-5	3261-5	3261-5	3261-5	3261-11	3261-11	3261-5
7	Pipe Plug (magnetic)	30160	30160	30160	30160	30160	30160	30160
8	Pinion Assembly	5046	5046	5046	5046	5046	5046	5046
9	"S" Hook	4270	4270	4270	4270	4270	4270	4270
10	Motor	4229	5703	4229	5703	5977	28031	24624
--	Cord Assembly	4685	8299	----	----	28028	----	----
--	Connector (Romex)	1317	1317	----	----	----	----	----
--	Connector (90 Degree)	----	----	----	----	4228	----	----

Power Unit Assembly Part Numbers:

Part No.	HP	RPM	Phase	Hz	Voltage	Usages
3259-84	1/3 HP	348 RPM	Single Phase	60 Hz	230	Use with all Control Units except 1878 Control Units
3259-85	1/2 HP	348 RPM	Single Phase	60 Hz	230	Use with all Control Units except 1878 Control Units
3259-98	1/2 HP	348 RPM	Single Phase	50 Hz	230	Use with all Control Units
3259-100	1/2 HP	348 RPM	Three Phase	50 Hz	220/380	Use with all Control Units
3259-128	1/2 HP	348 RPM	Three Phase	60 Hz	230	Use with all Control Units

Model H2 Plus Mechanical End Control

Silver Control: Part No. 40712

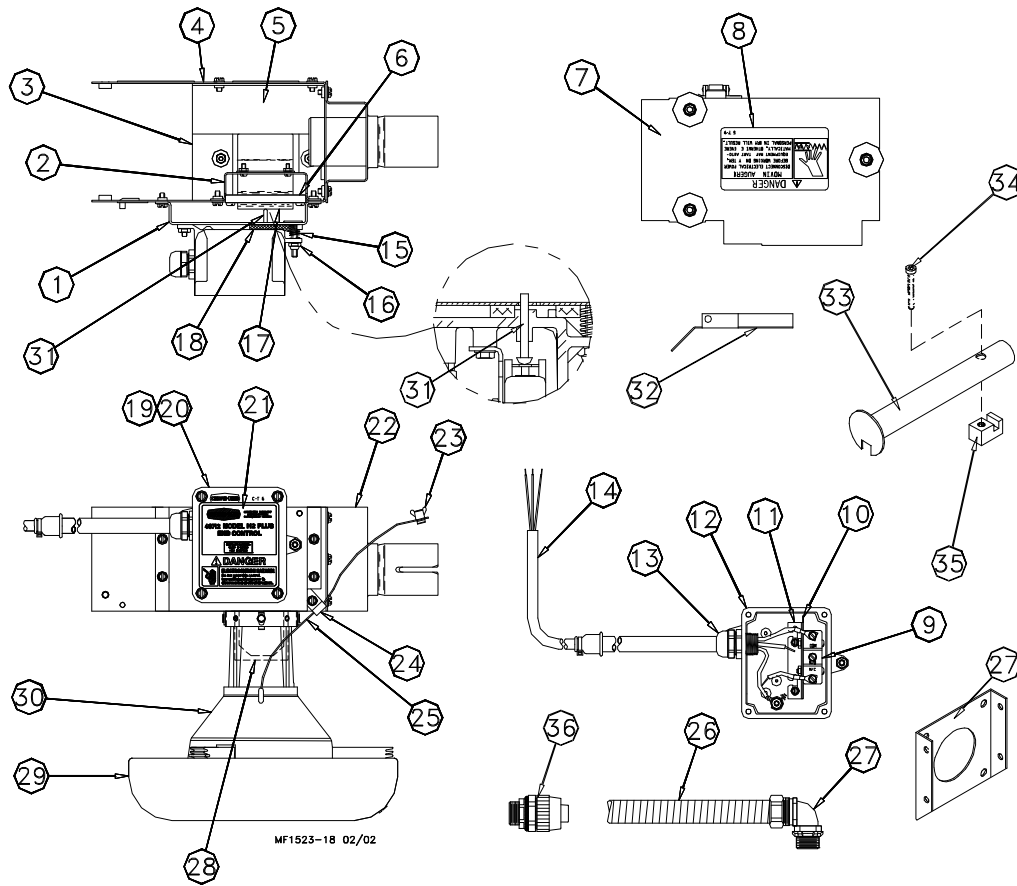

Item	Description	Part No.
1	Switch Box Mount	25084
2	Stop Panel	25433
3	Switch Bracket	34309
4	Control Body	14434
5	Deflector Panel	34310
6	Paddle Retainer	25045
7	Control Cover Assembly	24682
8	Danger Decal	2527-9
9	Actuator Switch	46091
10	Switch Insulation	1907-5
11	Switch Bracket	46122
12	Switch Box	24702
13	1/2" Water Tight Connector	24685
14	Control Cord Assembly	25495
15	Spring	6972
16	#10-32 Lock Nut	6963
17	Paddle	24848
18	Gasket	6968-1
19	Switch Box Cover	6776
20	Switch Box Gasket	6777
21	Control Decal (Control P/N 40712) Control Decal (Control P/N 40815)	2529-642 2529-647

Item	Description	Part No.
19	Switch Box Cover	6776
20	Switch Box Gasket	6777
21	Control Decal (Control P/N 40712) Control Decal (Control P/N 40815)	2529-642 2529-647
22	Support Bracket	24683
23	Cable Clamp	13057
24	1/8" Nylon Cable Clamp	34740
25	Cord Assembly	40388
26	14" Flexible Conduit	26982-1
27	1/2" Liquid Tight Connector	23810
28	Mylar Assembly	25310
29	Pan	24901
30	Center Support Assembly - Silver Center Support Assembly - Green	40796 40828
31	Actuator Pin	8757
32	Bottom Cover	14432
33	Drive Tube Weldment	44794
34	1/4-20 x 1-1/2" Socket Hd. Screw	5083-8
35	Driver Block	4642
--	Anti-Roost Guard	2798
--	Anchor	4188
--	Parts Package	40809

Model H2 Plus End Control

with Sensor Plus Switch

Silver Control: Part No. 45917

Green Control: Part No. 45916

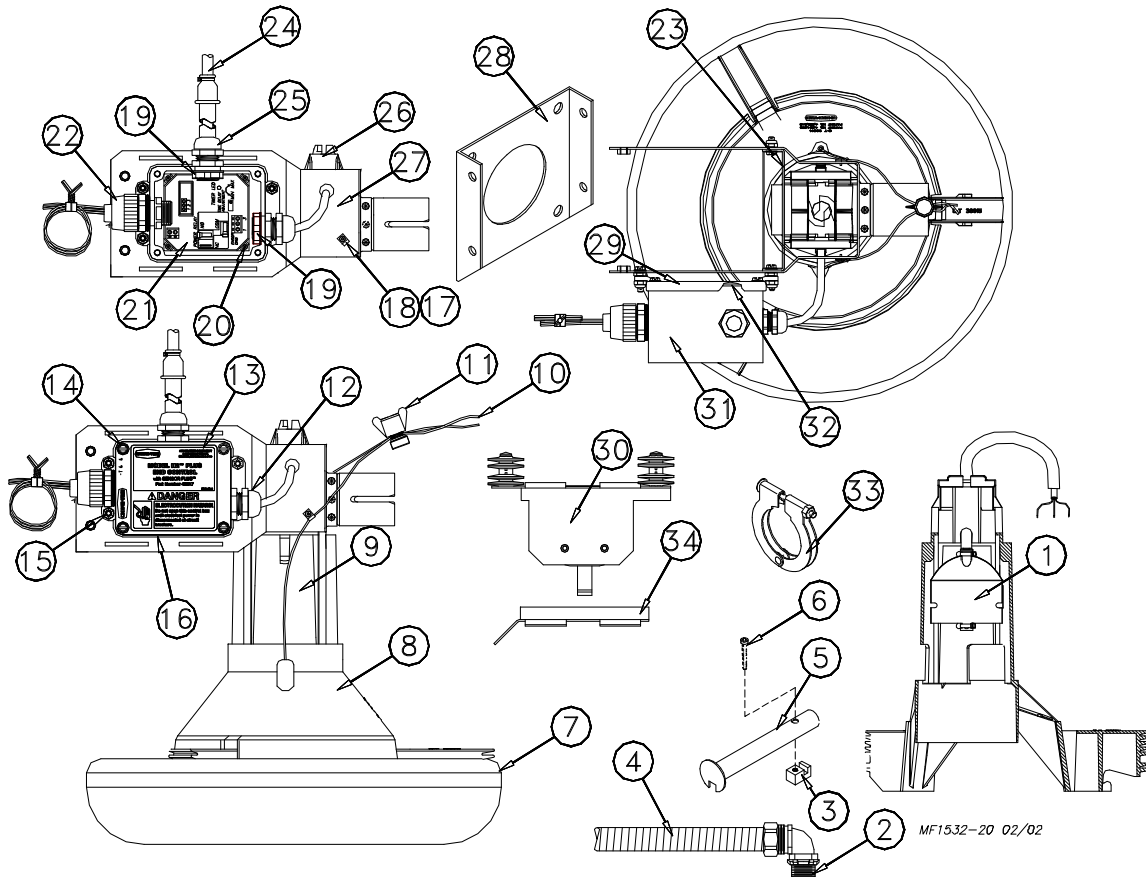

Item	Description	Part No.
1	Sensor Assy Pan (w/Sensor/Heat)	46673
2	1/2" Liquid Tight Connector	23810
3	Driver Block	4642
4	Flexible Non-Metallic Conduit	26982-1
5	Drive Tube Weldment	44794
6	Socket Hd Screw	5083-8
7	Model H2 Feeder Pan	24901
8	H2 Plus Feed Level Cone (Green) H2 Plus Feed Level Cone (Silver)	38914-2 38914-1
9	H2 Plus Support Cone	45920
10	24" Cord Assembly	40388
11	Split Bolt Split Bolt Cap	40787 40788
12	Liquid Tight Connector	23779
13	H2 Plus Control Decal (Green) H2 Plus Control Decal (Silver)	2529-741 2529-740
16	Switch Box Cover	6776
17	6-32 x .375" Self Drilling Screw	34660

Item	Description	Part No.
18	1/8" Nylon Cable Clamp	34740
19	Conduit Locknut	43662
20	4-24 x .375" Pan Hd. Screw	35493
21	Circuit Board	46673
22	Straight Liquid Tight Fitting	26980
23	Support Bracket	42081
24	Cord Assembly	4999-100
25	1/2" Liquid Tight Connector	24685
26	Slide Top Cap	38603
27	Control Body Weldment	42080
28	Anchor Plate	4188
29	Mounting Terminal Box Cover	6956
30	Top Cover w/Insulator	42082
31	General Purpose Terminal Box	42627-3
32	Gasket	6777
33	Clamp Assembly	24063
34	Bottom Cover	42085
--	Anti-Roost Guard	2798

Model H2 Plus Mechanical Intermediate Control

Silver Control: Part No. 40745

Green Control: Part No. 40817

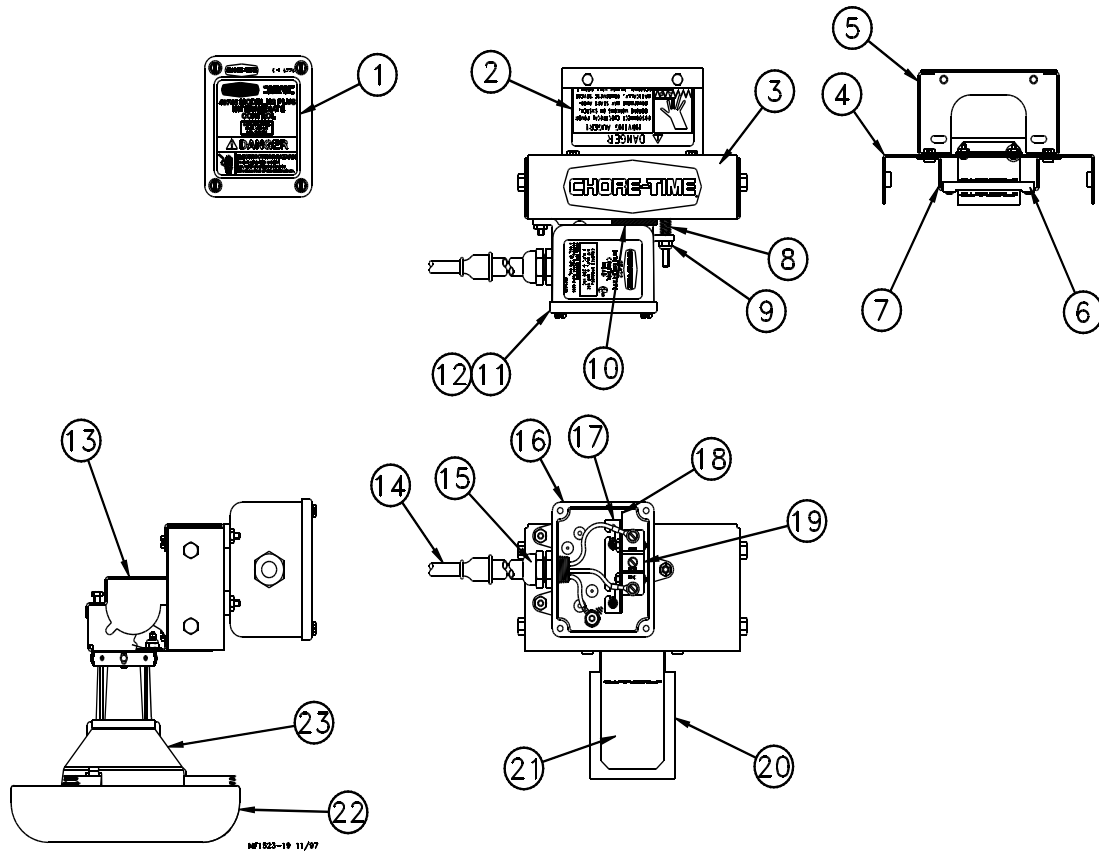

Item	Description	Part No.
1	Intermediate Control Decal - Silver	2529-643
	Intermediate Control Decal - Green	2529-649
2	Danger Decal	2529-9
3	Back Cover	25047
4	Front Panel	25046
5	Tube Support	14754
6	Paddle Retainer	25045
7	Pivot Bracket	25048
8	Spring	6972
9	#10-32 Lock Nut	6963
10	Gasket	6968-1
11	Switch Box Cover	6776
12	Gasket	6777

Item	Description	Part No.
13	Tube Retainer	14756
14	Cord Assembly	4999-49
15	1/2" Water Tight Connector	24685
16	Switch Box	34842
17	Switch Bracket	46122
18	Switch Insulation	1907-5
19	Actuator Switch	46091
20	Mylar Assembly	25318
21	Switch Paddle	46123
22	H2 Pan	24901
23	Center Support Assembly - Silver	40796
	Center Support Assembly - Green	40828
--	Actuator Pin	8757

Model H2 Plus Intermediate Control with Sensor Plus Switch

Silver Control: Part No. 45918

Green Control: Part No. 45919

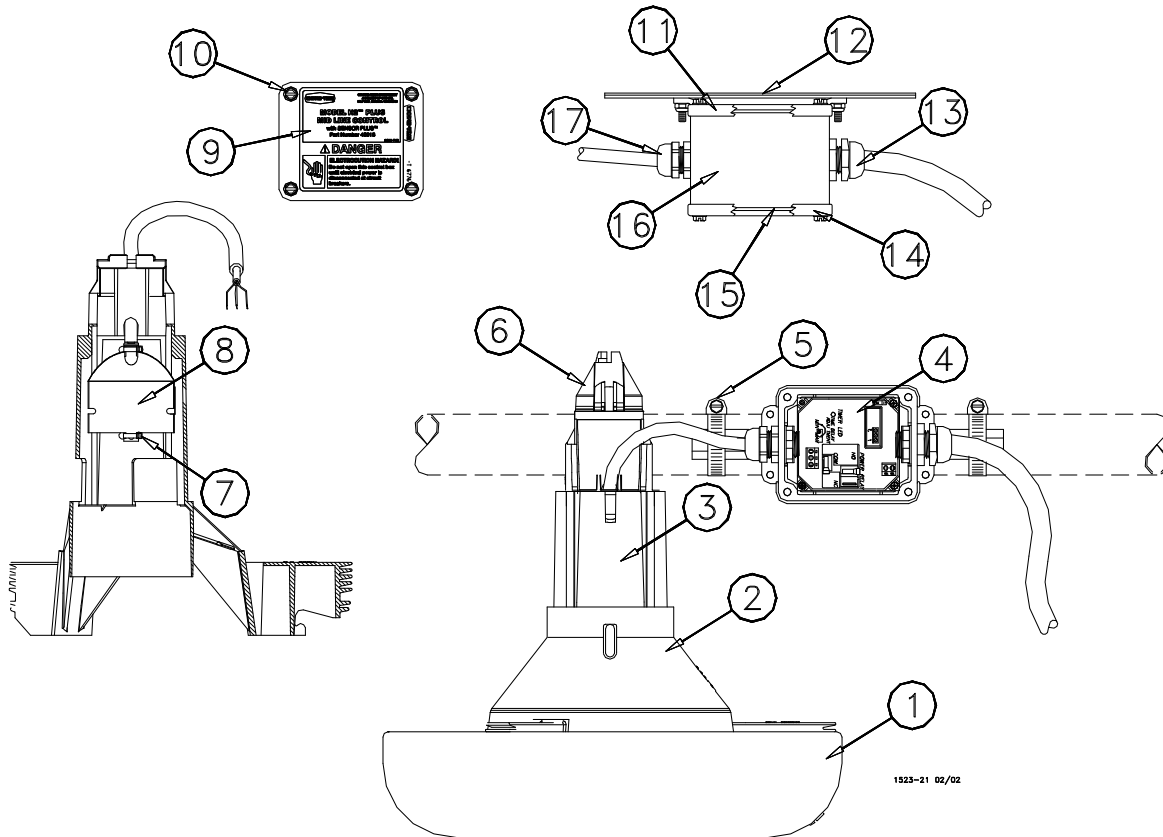

Item	Description	Part No.
1	Pan	24901
2	H2 Plus Feed Cone (Silver)	34914-1
	H2 Plus Feed Cone (Green)	34914-2
3	Model H2 Plus Support Cone	45920
4	Sensor Pan Assembly w/Sensor	46673
5	Hose Clamp	3527
6	Slide Top Cap	38603
7	Cable Tie	6635
8	Sensor Pan Assembly	46673

Item	Description	Part No.
9	End Control Decal - Silver	2529-742
	End Control Decal - Green	2529-646
10	Pan Head Screw	35493
11	Mounting Terminal Box Cover	6956
12	Tube Mount	42681
13	1/2" Liquid Tight Connector	24685
14	Switch Box Cover	6776
15	Gasket	6777
16	General Purpose Terminal Box	42627-2
17	1/2" Liquid Tight Connector	23779

Winch (part no. 47687)

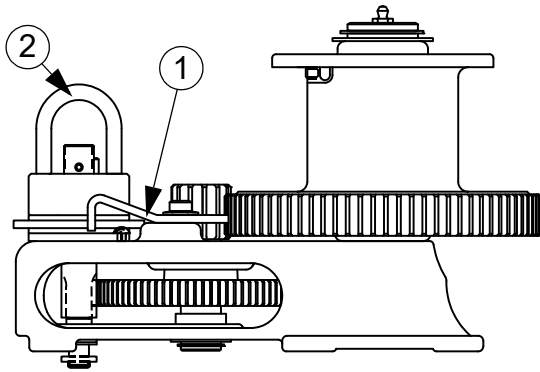

Item	Qty.	Description	Part No.
1	1	Pawl	47687-5
2	1	Input Shaft Assembly	47687-1

Miscellaneous Suspension Components

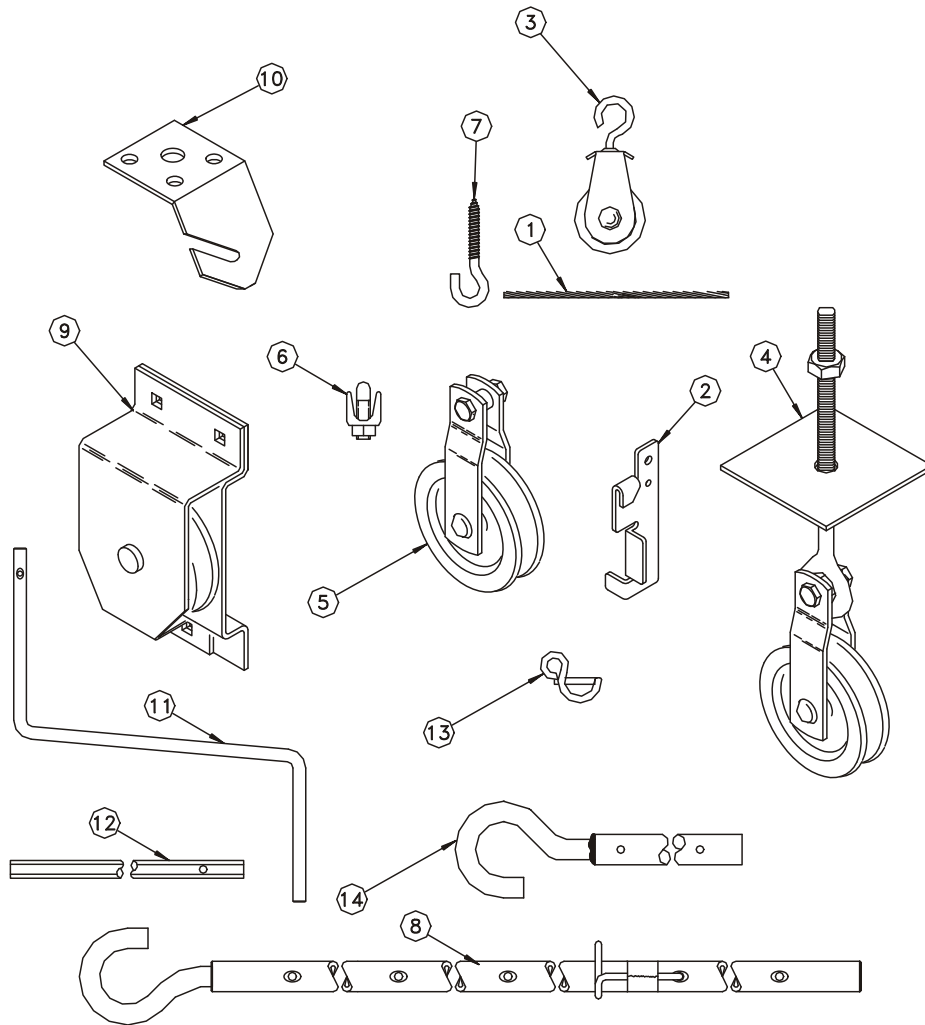

MF232-58 9/96

Item	Description	Part No.
1	3/16" Cable	1213
2	Cable Lock	14337
3	Pulley with Swivel	3004
4	Heavy Duty Pulley Assembly	2014
5	Pulley	2500
6	3/16" Cable Clamp	732
7	Screw Hook	2041
8	Extendable Drive Tube	47637
9	Pulley Assembly	28429
10	Ceiling Hook	28550
11	Handle Shank	3148

Item	Description	Part No.
12	Drill Adapter Shaft	2886
13	Winch Handle Pin	3761
14	Winch Drive Tube (4')	2884-1
	Winch Drive Tube (8')	2884-2
	Winch Drive Tube (2')	2884-4
--	Full Line Suspension Kit	7948

Items 11 and 13 may be ordered as a kit under part no. 2885.

Items 12 and 13 may be ordered as a kit under part no. 2886.

Items 11, 13, and 8 may be ordered as a kit under part no. 47638.

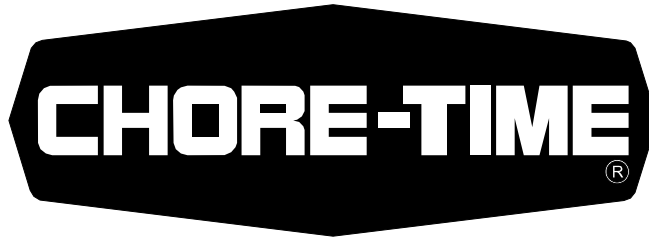

**MADE TO WORK.
BUILT TO LAST.®**

Revisions to this Manual

Page No.	Description of Change	ECO
54	Was 2883 Winch	35577
Various	Updated Graphics	

**For additional parts and information, contact your nearest Chore-Time distributor or representative.
Find your nearest distributor at: www.choretime.com/contacts**

CTB, Inc.
PO Box 2000
Milford, Indiana 46542-2000 USA
Phone (574) 658-4101
Email: choretime@choretime.com