

RELIA-FLOW®, STEADI-FLOW® and ADVANTI-FLOW®

Nipple Drinking Systems and Accessories

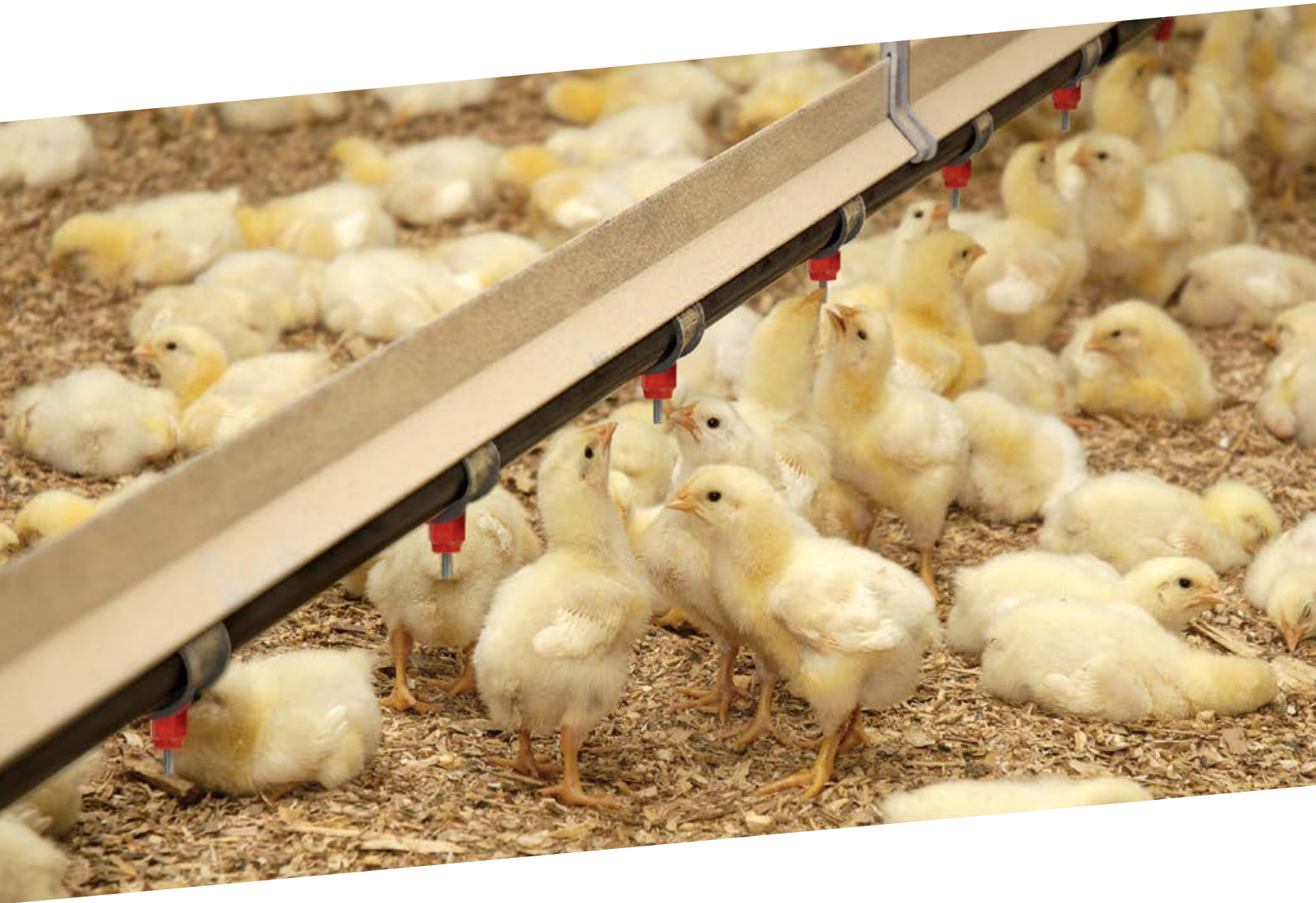

Let's grow together®



Chore-Time's Drinkers Provide a Reliable Flow Rate Consistent with the Way Birds Drink

Four different flow rates for various bird types and environments

- RELIA-FLOW® Nipple Drinkers for broilers and breeders feature precision-machined, stainless steel parts throughout the flow control area for long life and consistent, reliable flow.
- STEADI-FLOW® Nipple Drinkers for broilers and breeders use stainless steel parts coupled with industrial grade CPVC plastic for flow control.
- ADVANTI-FLOW® Drinkers for poults feature RELIA-FLOW® Drinker Technology for flow control together with a uniquely shaped disc and cup especially designed for young turkeys.



Count on Chore-Time for
experience, reliability,
performance and confidence.

Chore-Time Drinking Systems

When you grow with Chore-Time, you get the drinking system components and accessories you need to provide plenty of fresh water to your birds. Every grower knows how critical water is to starting birds well and keeping them healthy and productive.

Choose one of Chore-Time's proven drinking systems and pair it with our one-of-a-kind PDS Control to ease your drinker management chores. Read more in the pages that follow about these top-performing models, and glean some application and management tips as well:

- PDS™ (Pneumatic Drinking System) Controls
- RELIA-FLOW® & STEADI-FLOW® Drinker Comparison
- University-Confirmed Flow Rate Data
- Broiler, Breeder & Poult Drinkers
- Drinker Application/Management Data
- Drinking System Options and Accessories

PDS™ Controls for RELIA-FLOW® and STEADI-FLOW® Drinkers

Simple Drinking System Management with Chore-Time PDS™ Controls

Chore-Time's PDS™ (Pneumatic Drinking System) Controls offer poultry producers convenient control of the water pressure in all nipple drinker lines in the house.

- Change the pressure in all lines or flush all lines from one remote location.
- Program PDS Controls to automatically flush water lines as often as four times per day or as seldom as once a week.
- Easily run "flush stimulations" to get cool water to the birds during hot weather.

Easy-to-Program Control for up to 16 Regulators



Patented & Additional Patent(s) Pending
A model for up to 80 regulators is also available.

Be One of the Satisfied Customers Who Have Experienced the RELIA-FLOW® Drinker's Reliability and Performance!

My two Relia-Flow houses are drier than the other six [houses], but performance is way better [with] heavier birds over the last five flocks.
Alabama Grower

I am completely satisfied with Relia-Flow drinkers. My floors are staying dry, but the weight of my birds has not suffered.
Georgia Grower

Chore-Time's Drinkers Feature a Flow Rate Consistent with the Way Birds Actually Drink



Let's grow together®

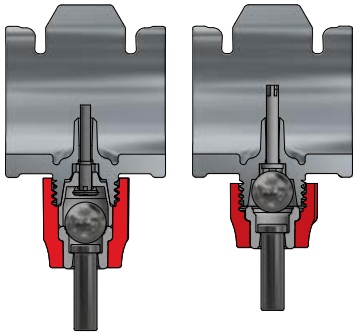

Chore-Time's RELIA-FLOW® and STEADI-FLOW® Drinkers provide a reliable flow rate that is consistent with the way birds drink. Testing demonstrates that Chore-Time's drinkers provide abundant water for birds. After all, the real measure of drinker performance is how much ends up in the birds, not in the measuring cup!

RELIA-FLOW® Drinker	STEADI-FLOW® Drinker	
X	X	CPVC Industrial Grade Saddle
X	X	Raised Inlet Protects Valve from Debris
X	X	Four Flow Rates
X	X	Triple Seat Valve for Reliable Seal
X	X	Precision Machined, Stainless Steel Parts
	X	Stainless on CPVC Flow Control
X		Stainless on Stainless Precision Flow Control
X		Fully-Assembled, "Unitized" Valve

RELIA-FLOW® Features and Benefits

- Robust, precision-machined, stainless steel parts in flow-control area resist wear and retain their shape for long life and consistent, reliable flow.
- Unitized, fully-assembled, one-piece valve is easily field replaceable to simplify retrofitting.

RELIA-FLOW® and STEADI-FLOW® Features

- Special assembly process attaches saddle to pipe for a tight, consistent fit without the use of glue, gaskets or sonic welding.
- Various available flow rates provide optimum water supply for chickens of all types and finishing weights and help maintain good litter conditions.



Fully assembled RELIA-FLOW® valve is easily field replaceable for retrofit applications.

University Test* Results

"Finger" Flow Rate (Manual)

(In ml/min. at 14 inches of water column & 70° F)

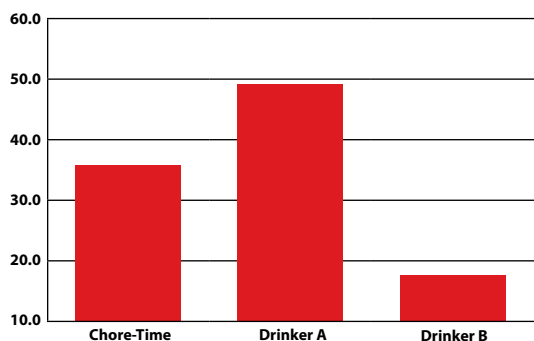

In independent tests, Chore-Time's RELIA-FLOW® Drinker had a "finger" (manually triggered) flow rate between the other two drinkers tested.

Bird Flow Rate

(In ml/min. at 14 inches of water column & 70° F)

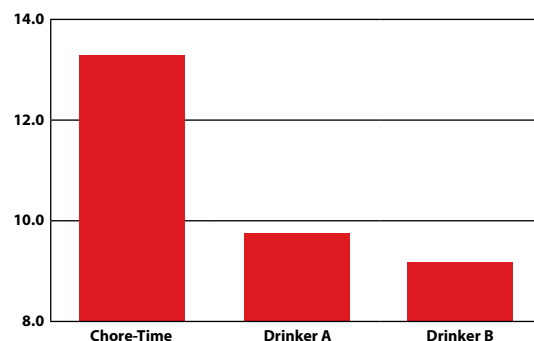

Yet, Chore-Time's "bird" flow rate was substantially greater than either of the other drinkers, proving that so-called "finger" flow does not determine bird flow.

* 2005. E.F. Wheeler, Associate Professor, and P.A. Topper, Research Technologist (Agricultural and Biological Engineering Department, The Pennsylvania State University)

Broiler Drinkers (for Birds up to Nine Pounds or More)

RELIA-FLOW® Nipple Drinking System for Broilers

STEADI-FLOW® Broiler Drinker Also Available

Chore-Time's Broiler Drinker Systems feature a water metering system with all stainless steel (RELIA-FLOW®) or all stainless steel on plastic (STEADI-FLOW®) parts in the flow control area for long-term delivery of the intended flow rate. Field results and accelerated life-cycle testing in our lab show that the flow remains consistent year after year.

- Precision-machined, stainless steel parts in flow-control area.
- Drinkers can be triggered from 360° which helps young birds start well and makes drinking easier.
- All parts resist corrosion, and the gray PVC pipe blocks light to minimize algae growth.
- Saddle-to-pipe structure minimizes leaks by using a special assembly process without glue or o-rings.
- Rigid aluminum support channel also serves as an anti-roost device.
- Factory-assembled sections are easy to install and to operate and have low maintenance requirements.
- Proven history of providing plenty of water for birds.



Chore-Time's broiler nipple is easy for birds to trigger from day one for optimum early feed conversion.



Recommended Broiler Drinker Options

Flow Rate Climate	Channel Style	Catch Cup	Straight (S) or Button (B)	Birds Per Nipple	
				Start	Grow-Out
Regulated Flow Cool Climates Only	Standard	No	S or B	30	10 to 15
Standard Flow Cool to Hot Climates and Environmentally Controlled Houses	Standard	No	S or B	30	10 to 15
High Flow Option Hot Climates	Standard	Yes	S or B	30	10 to 15
Super High Flow Option Extremely Hot Climates & Houses with Minimal Ventilation	Standard	Yes	S	30	10 to 15

These recommendations are intended to be used as guidelines only. Many other factors such as ventilation; bird type, size and weight; climate conditions; etc. must be considered when choosing the correct system and flow rate. Choosing a system without considering these factors can result in poor litter conditions and poor performance. Contact your local authorized Chore-Time distributor for help in matching the best system with your individual needs.



Four available flow rates help growers to provide the right amount of water for their climate and house conditions.

Breeder Drinkers

RELIA-FLOW® Nipple Drinking System with Lift Trigger

STEADI-FLOW® Breeder Drinker Also Available



Let's grow together®

The lift trigger mechanism of Chore-Time's Breeder Drinker System sets it apart from other breeder drinkers. With a shorter nipple pin and less lateral movement, the lift trigger is designed to get more water in the birds and less on the floor. Birds learn to drink directly under the nipple in a position that spills less water and avoids inadvertent triggering.



Chore-Time's breeder nipple has a shorter nipple pin and less lateral movement so both hens and roosters learn to drink directly under the nipple in a position that wastes less water.

- Chore-Time breeder drinking systems are designed to encourage faster water consumption for quicker movement to nests and fewer floor and slat eggs.
- Drinkers feature stainless steel valve components and PVC pipe, valve housing, saddle and hangers.
- Heavy-duty, rigid aluminum support channel resists corrosion better than galvanized conduits or pipe.
- Saddle-to-pipe structure minimizes leaks by using a special assembly process without glue or o-rings.
- Factory-assembled sections simplify installation, and systems are easy to operate and maintain.
- With Chore-Time, producers can maintain a lower drinker line height to accommodate variations in bird size and still keep floors and slats drier.

Recommended Pullet Drinker Options

Flow Rate Climate	Channel Style	Catch Cup	Lift Trigger	Straight (S) or Button (B)	Birds Per Nipple	
					Start	Grow-Out
Standard Flow Cool to Hot Climates and Environmentally Controlled Houses	Standard	No	N/A	S or B	16 to 24	8 to 12
	Heavy-Duty	No	N/A	S or B	16 to 24	8 to 12
High Flow Option Hot Climates	Standard	Yes	N/A	S or B	16 to 24	8 to 12
	Heavy-Duty	Yes	N/A	S or B	16 to 24	8 to 12



A breeder drinking system with catch cups is also available.

Recommended Breeder Drinker Options

Flow Rate Climate	Channel Style	Catch Cup	Lift Trigger	Straight (S) or Button (B)	Birds Per Nipple
Standard Flow Cool to Hot Climates and Environmentally Controlled Houses	Heavy-Duty	No	Yes	S	10 to 12
High Flow Option Hot Climates	Heavy-Duty	Yes	Yes	S	8 to 10

These recommendations are intended to be used as guidelines only. Many other factors such as ventilation; bird type, size and weight; climate conditions; etc. must be considered when choosing the correct system and flow rate. Choosing a system without considering these factors can result in poor litter conditions and poor performance. Contact your local authorized Chore-Time distributor for help in matching the best system with your individual needs. Anti-roost system required.

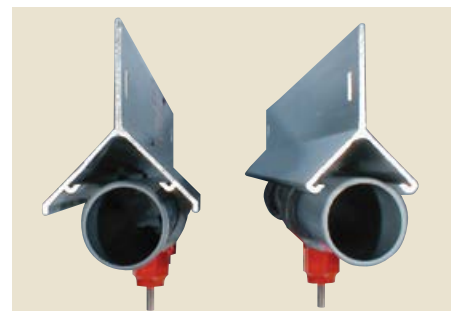

Two support channel options are available – heavy-duty (left) or standard.

Poult Drinkers (for Birds up to Six Weeks)

ADVANTI-FLOW® Drinker for Poults

Featuring RELIA-FLOW® Drinker Technology

- Poults get off to a good start by drinking from nipple discs and from litter-saving dual catch cups. The discs also provide leverage for easier triggering during brood.
- “Pockets” in the uniquely designed drinker disc hold water to attract poults and also direct water toward birds as they drink.
- Innovative dual catch cups have a rounded edge for bird comfort and shallow depth to help prevent build-up.



Patented

Birds Get Plenty of Water and Floors Stay Drier!



The uniquely designed drinker disc features “pockets” which hold water to attract poults. Chore-Time’s ADVANTI-FLOW® Drinker also includes catch cups with a rounded edge for greater bird comfort.

Recommended ADVANTI-FLOW® Poult Drinker Options

Flow Rate	Channel Style	Catch Cup	Nipple Style	Birds Per Nipple
High Flow	Standard	Yes	Disc	10 to 16

These recommendations are intended to be used as guidelines only. Many other factors such as ventilation; bird type, size and weight; climate conditions; etc. must be considered when choosing the correct system and flow rate. Choosing a system without considering these factors can result in poor litter conditions and poor performance. Contact your local authorized Chore-Time distributor for help in matching the best system with your individual needs. Anti-roost system required.

Nipple Drinker Height Guidelines

See Chore-Time’s Installation and Operation Manual for Complete Details

Floor conditions are a good indication of adequate or deficient water supply. If the floors are wet, the water column may be too high. If the floors are dry, the water column may be too low.

IMPORTANT NOTE: These are general guidelines – your particular house environment may require different adjustments.

1 - 3 Days

At 1 - 3 days set the nipple height as shown below. The water column should be set at 2 - 4 inches (50 - 100 mm) as shown at right.

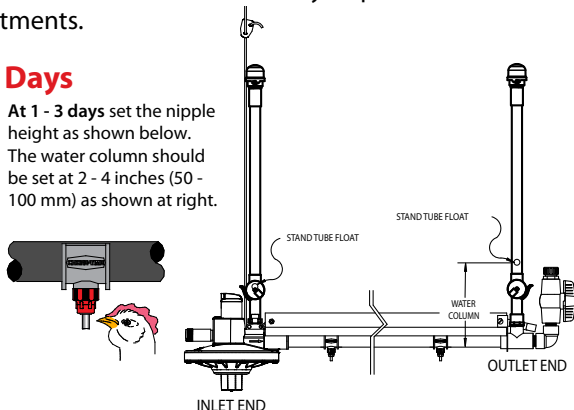

3 - 21 Days

At 3 - 21 days set the nipple height as shown below. The water column should be set at 4 - 8 inches (100 - 200 mm) as shown at right.

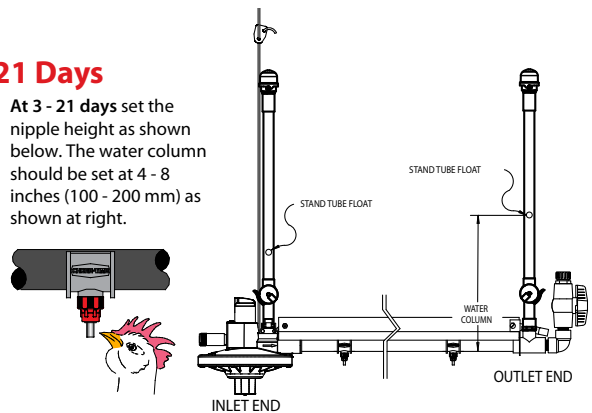

21 Days - Grow-Out

At 21 days to grow-out set the nipple height as shown below. The water column should be set at 8 - 22 inches (200 - 560 mm) as shown at right.

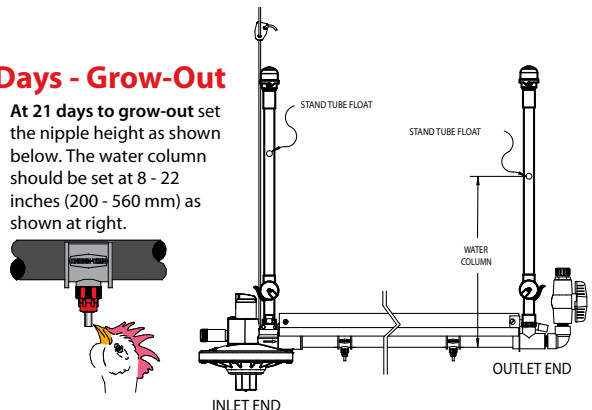

Chore-Time Drinker Ordering Information and Management Recommendations



Let's grow together®

Following these guidelines will help you to determine the nipple spacing you need.

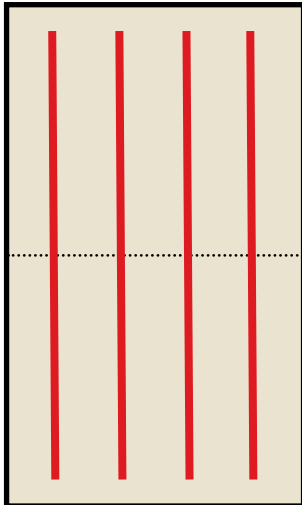

BROOD AREA
240' (2,880") per
drinker line
2,880" x 4 lines
= 11,520" of
drinker line

GROW-OUT AREA
240' (2,880") per
drinker line
2,880" x 4 lines
= 11,520" of
drinker line

This example uses a 500-foot broiler house with 31,250 birds, four lines of drinkers and half-house brooding.

Brood Area (Example)

Goal: No more than 30 broilers per nipple in brood area
31,250 birds in house ÷ 30 birds per nipple = 1,041 nipples
11,520" of drinker line ÷ 1,041 nipples = 11.06" between nipples
Round down to nearest available spacing (6, 8, 10, 12 or 15 inches)*
11.06" rounds down to 10"
11,520" of drinker line ÷ 10" nipple spacing = 1,152 nipples
Result: 31,250 birds ÷ 1,152 nipples = 27.1 birds per nipple

Grow-Out Area (Example)

Goal: No more than 15 broilers per nipple in grow-out area
Assume that half the birds (15,625) are in the grow-out area
15,625 birds ÷ 15 birds per nipple = 1,041 nipples
11,520" of drinker line ÷ 1,041 nipples = 11.06" between nipples
Round down to nearest available spacing (6, 8, 10, 12 or 15 inches)*
11.06" rounds down to 10"
11,520" of drinker line ÷ 10" nipple spacing = 1,152 nipples
Result: 15,625 birds ÷ 1,152 nipples = 13.6 birds per nipple

*Popular nipple spacing options include 6, 8, 10, 12 & 15 inches. Additional nipple spacing options are also available. Suggestions made in this nipple spacing example are general in nature. They are intended to show how to calculate nipple spacing, but they are not prescriptive. Specific calculations for your poultry house will depend on your particular circumstances and may be different. For help planning a Chore-Time Nipple Drinking System, please contact your local authorized Chore-Time distributor (www.choretime.com/contacts).

Best Practices for Drinker System Management

Chore-Time strongly recommends a regular cleaning program to eliminate water line contaminants.

Flush Drinker Lines Before Each Flock

- Flush drinker lines at full pressure for five minutes to remove deposits and sediments.
- Keep the lines free of restrictions such as small valves and hoses which could prevent the free flow of water during flushing.
- Do not flush all lines at once to help insure sufficient water pressure during flushing.

Flush After Medicating and After Cleaning

- Medications, vaccines and vitamins are potential food for bacteria and algae if not removed from the line.
- Cleaners should not be left in the drinker line for extended periods of time.
- Do not mix chemical cleaners with other chemicals, vitamins, vaccines or supplements

– the result could be sediment, a filmy residue or even a corrosive substance.

Have Water Tested and, If Necessary, Treated*

- Consider factors such as the depth of the well, daily water usage, pH of the water and a detailed chemical breakdown of the water.
- Evaluate the treatment suppliers carefully before selecting a treatment system.
- Good water quality is key to the proper performance of all poultry drinkers as well as to the palatability of the water for the birds.

*Use caution when treating water to avoid damage to your drinker system. Corrosion, material deterioration and/or equipment malfunction caused by or consistent with excessive additions of chemicals, minerals, sediments or other foreign elements will void your warranty. See Chore-Time's full warranty for complete warranty details.



Drinking System Options and Accessories



Self-Filling Mini Drinker with large float ball snaps over drinker saddle.



Catch Cup option for High Flow and Super High Flow systems.

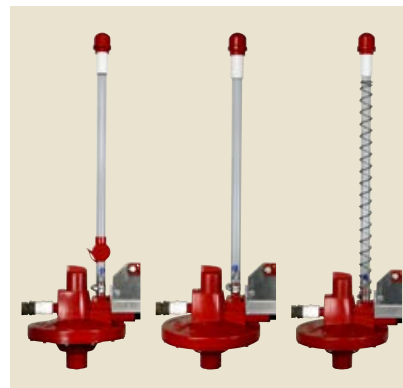

Stand Tube Options (from left) include folding, rigid and flexible styles.



Same VOLUMATIC™ Regulator for both pneumatic and regular function. User can select default water pressure in case air pressure is interrupted.



Slope Compensator makes it easier to manage increased water column due to floor slope.

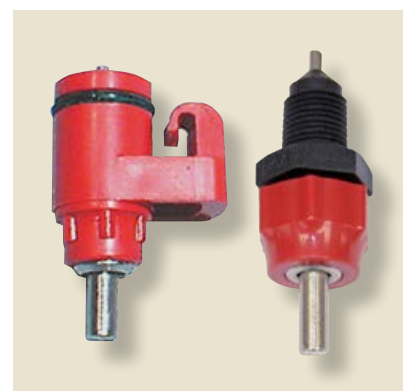

J-Type and Threaded Body Replacement Valves are available for retrofit use.



Breather Cap helps keep dust out of the water line and removes air faster.



Replaceable Filter
Opaque or Transparent



Flushable Filter

Optional Pre-Assembled Filter Control Panels include a water filter, medicator hook-up and all the necessary plumbing. They are ready to hang and connect.



Watering Bracket clamping design increases drinker line stability.

Find your authorized independent distributor at choretime.com/distributor



Let's grow together®

www.choretime.com

Chore-Time is a division of CTB, Inc.
A Berkshire Hathaway Company

Chore-Time
Milford, Indiana USA
info@choretime.com

Chore-Time Europe Sp. z o.o.
Strykowo, Poland
info@choretime.pl

Chore-Time Europe B.V.
Panningen, Netherlands
info@choretime.nl

Chore-Time Ede B.V.
Ede, Netherlands
info@choretime.nl