



48" and 52" Vanguard Plus Belt Drive Fans Installation and Operators Instruction Manual



Thank You

The employees of CTB Inc. would like to thank you for your recent Chore-Time purchase. If a problem should arise, your Chore-Time distributor can supply the necessary information to help you.

Note: The original, authoritative version of this manual is the English version produced by CTB, Inc. or any of its subsidiaries or divisions, (hereafter collectively referred to as "CTB"). Subsequent changes to any manual made by any third party have not been reviewed nor authenticated by CTB. Such changes may include, but are not limited to, translation into languages other than English, and additions to or deletions from the original content. CTB disclaims responsibility for any and all damages, injuries, warranty claims and/or any other claims associated with such changes, inasmuch as such changes result in content that is different from the authoritative CTB-published English version of the manual. For current product installation and operation information, please contact the customer service and/or technical service departments of the appropriate CTB subsidiary or division. Should you observe any questionable content in any manual, please notify CTB immediately in writing to: CTB Legal Department, P.O. Box 2000, Milford, IN 46542-2000 USA.

Contact your nearby Chore-Time distributor or representative for additional parts and information.

CTB, Inc.

PO Box 2000

Milford, Indiana 46542-2000 USA

Phone (574) 658-4101 Fax (877) 730-8825

Email: choretime@choretime.com

Internet: www.choretime.com

Fan and Fan Framing Dimensions

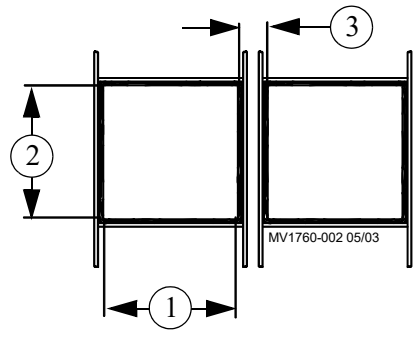
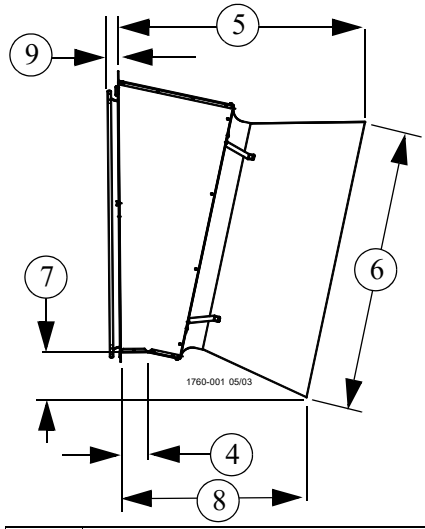

Planning the layout of the spacing between fans is very important. Spacing too close together will cause interference between Discharge Cones. Rough Openings for Fans are shown above.

Item	Description	
	48" Fans	52" Fans
1	55" [139.7 cm]	56-1/2" [143.51 cm]
2	57-1/2" [146.05 cm]	58" [147.32 cm]
3	4" [10.16 cm] Minimum	8" [20.32 cm] Minimum
4	5-3/4" [14.61 cm]	6" [15.24 cm]

Item	Description	
	48" Fans	52" Fans
5	51-3/4" [131.45 cm]	51" [129.54 cm]
6	59" [149.86 cm]	64" [162.56 cm]
7	9-3/4" [24.77 cm]	10-1/4" [26.04 cm]
8	39" [99.06 cm]	40" [101.6 cm]
9	2-1/4" [5.7 cm]	2-1/4" [5.7 cm]

Mounting Fan in Wall

Install the Fan into the wall opening with the Decals at the bottom as shown. Use 7 Lag Screws to attach the Fan to the Wall in the locations shown.

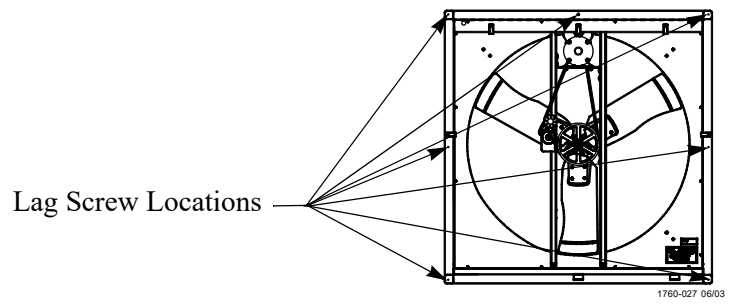

Do Not operate these Fans with a variable speed control device. Operating static pressure should be less than 0.15 inches water column.

Cone Assembly

The Fan Cone is assembled by interlocking four identical Panels (See Figure below). Use a piece of lumber to prop up the end of a Panel with slots. Interlock two Panels by sliding the tabbed end of another Panel into these slots. Repeat this process to attach all four Panels. The Panels when assembled should form a continuous "C" shape as shown. With the Panels interlocked and laying flat on the ground, stand the Panels up on edge and curl them into a Cone shape with the tabs to the inside of the Cone. Interlock the two remaining edges to form the complete Cone. Turn 5/16x 1-1/4 Hex Bolts into the four holes near the upper edge of the Cone. The bolt heads need to be on the inside of the Cone as shown.

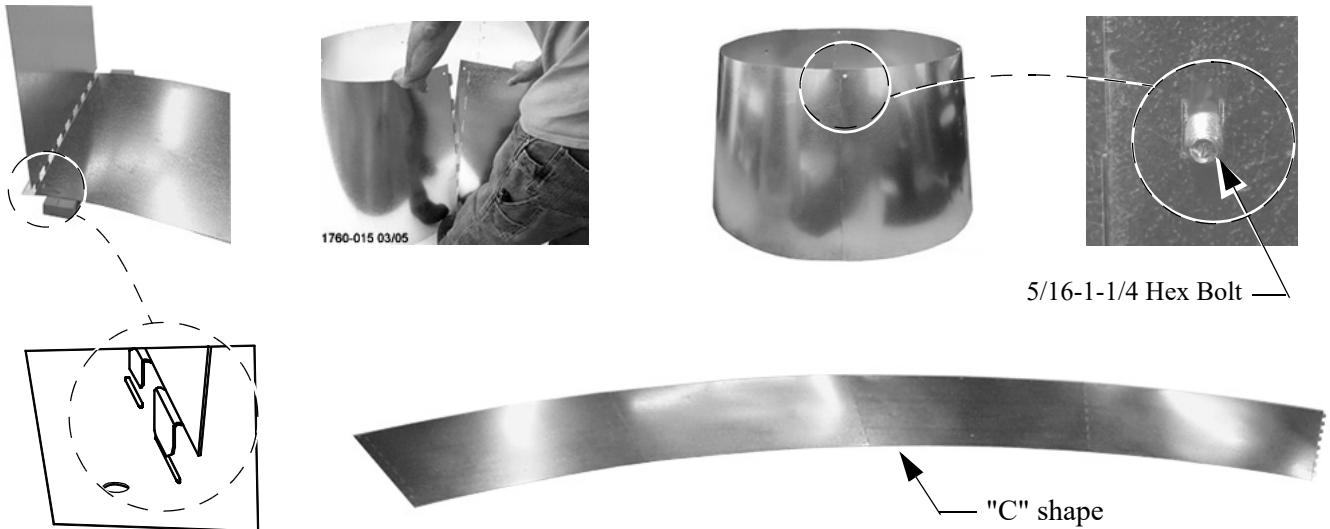

Flip the Cone over so that the large end is up, and install the Grill using 5/16 Carriage Bolts and Flange Nuts.

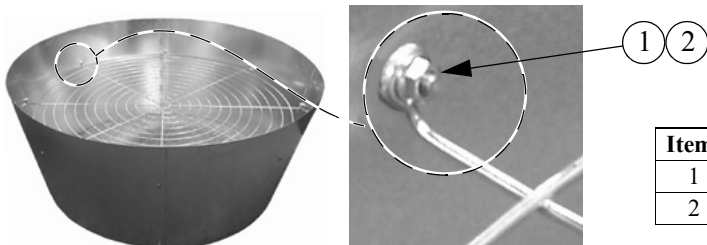

Item	Description
1	5/16 Carriage Bolt
2	5/16 Hex. Nut

Use 5/16 Carriage Bolts and Flange Nuts to attach the Cone Brackets to the Fan Shroud as shown. Pick up the Cone and rest it on top of the Fan orifice. Line up the 5/16 Flange Bolt previously threaded into the Cone with the holes in the Cone Brackets and fasten with 5/16 Flange Nuts. Working around the Fan Orifice in a circular motion Slide the Cone over the Fan Orifice. The Cone will Fit snug. Use 5/16-18 Flange Nuts to secure the bottom of the Cone to the Cone Brackets.

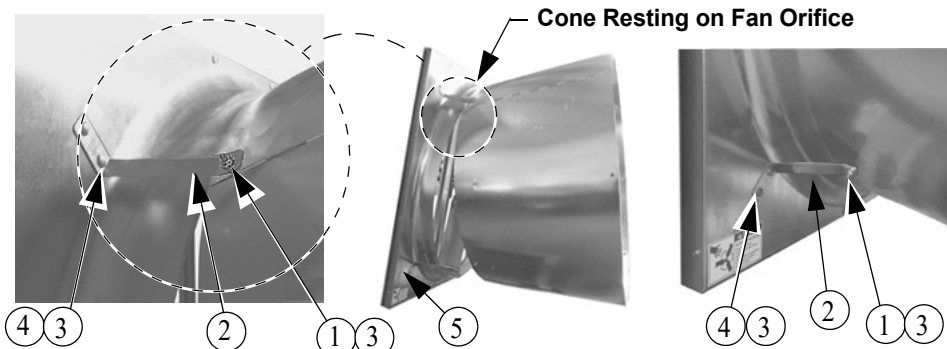

Item	Description
1	5/16 x 1-1/4 Hex Bolt
2	Cone Bracket
3	5/16 Flange Nut
4	5/16 Carriage Bolt
5	Fan Shroud

Wiring

1. Install an electrical disconnect within reach of each Fan installed.
2. Remove the Motor Access Cover.
3. Remove the electrical knock-out nearest the Fan power supply outlet.
4. Install the Romex Connector and cord through the knock-out selected before wiring the motor. Connect the cord to the motor according to the wiring diagram on the motor. Verify that the motor is connected for counter clockwise rotation (viewing the back of the motor, opposite the shaft end.)

Follow local, state, and national electrical codes for wiring.

5. Attach the cord to the Top Panel of the Fan using the Cord Clip, to keep the cord off the Shutter.
6. Allow enough slack in the cord to form a "drip loop" for moisture to fall away from the cord and not run into the motor.
7. Remove the slack in the cord between the Cord Clip and the Romex Connector and then tighten the Romex Connector.

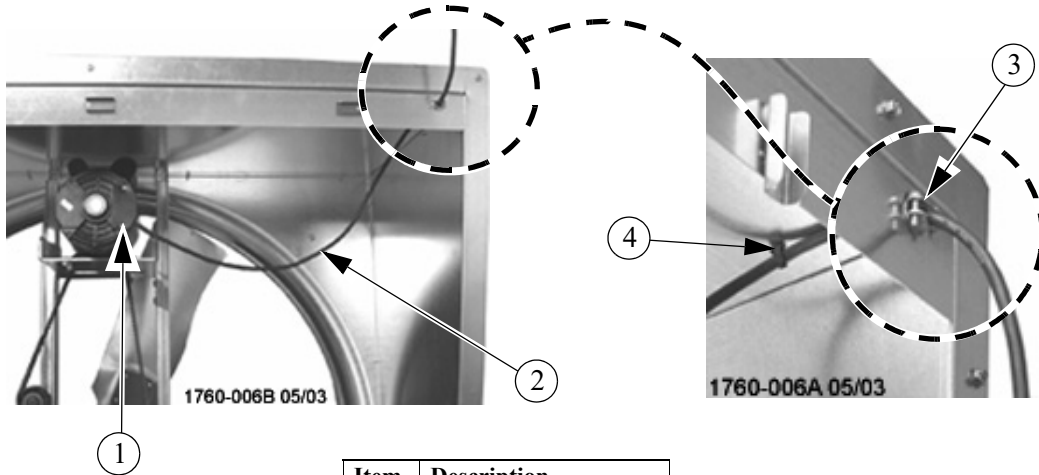

Item	Description
1	Motor Access Cover
2	Drip Loop
3	Romex Connector
4	Cord Clip

Wire Tie Removal/ Belt Installation

1. Cut and remove the Wire Tie from the Driven Sheave as shown.

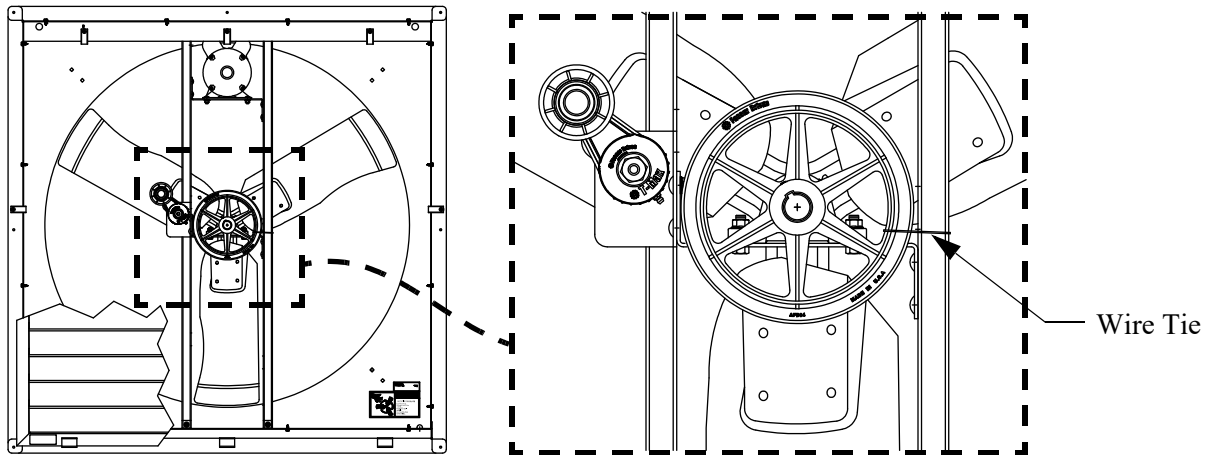

Belt Installation

1. Install the Belt as shown.

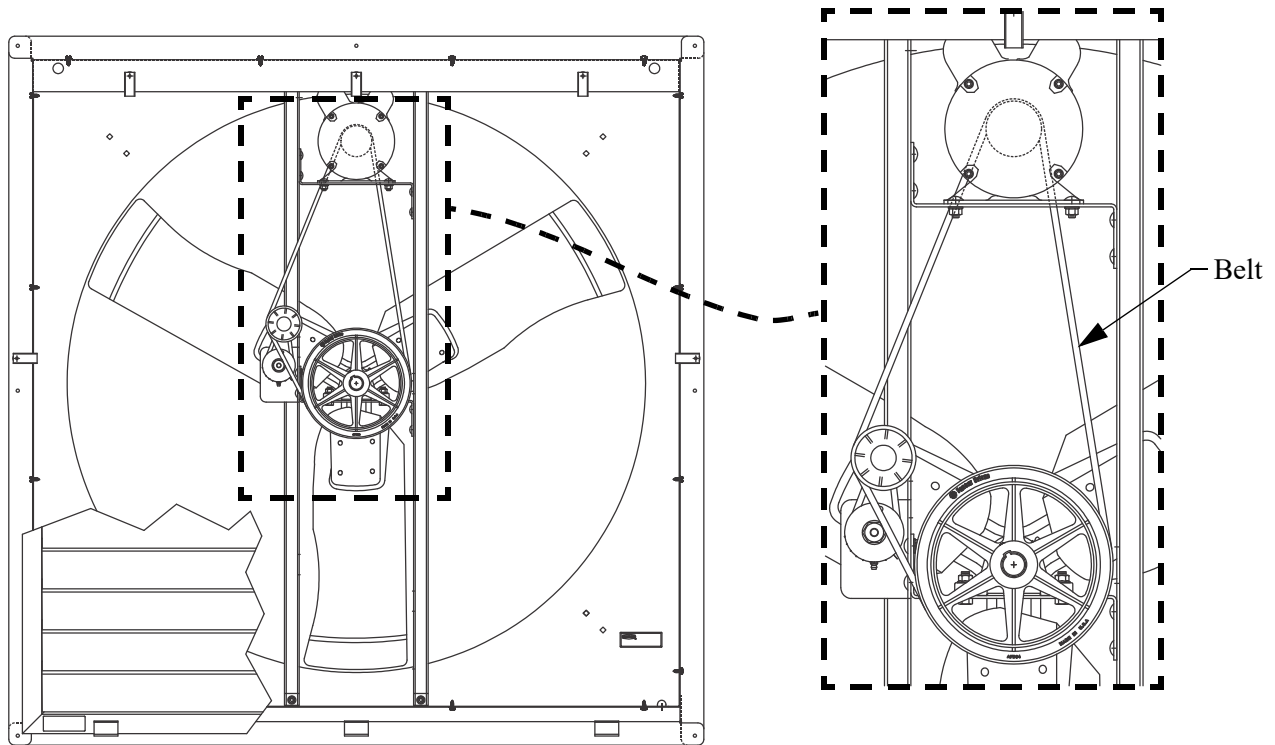

Shutter Installation

The Bottom Panel is designed with 3 tabs, **(Item 1, Figure below)**, to hold the Shutter. Slide the bottom of the Shutter into the Tabs, lean the Shutter into the Fan and lock the Shutter in place by rotating the (5) Shutter Clips **(Item 2)**. Check the Shutter for proper operation. The Shutter Louvers must be able to open and close freely.

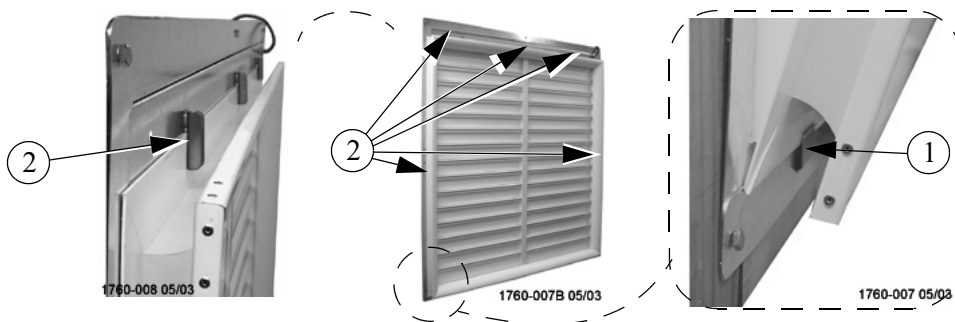

Item	Description
1	Tabs
2	Shutter Clips

Maintenance

IMPORTANT! Disconnect Power Prior To Maintaining Or Cleaning The Fan. The fan may start automatically causing serious injury or death.

- Service and repair of fans should be done only by a qualified technician.
- Minimize contact of moisture or corrosive chemicals to the surfaces of the fan components to maximize fan life.
- After washing fans, operate fans long enough to remove moisture from all fan surfaces.
- Keep the fan clean for maximum life and best performance. **Do Not spray water on the Fan Shaft Bearings, the Belt Tensioner, or the Motor.**
- Periodically check the V-Belt and replace if necessary. A worn Belt will cause a substantial drop in Fan performance or it can break and cause Fan failure. If a Belt rides below the Sheave edge, replace the belt.

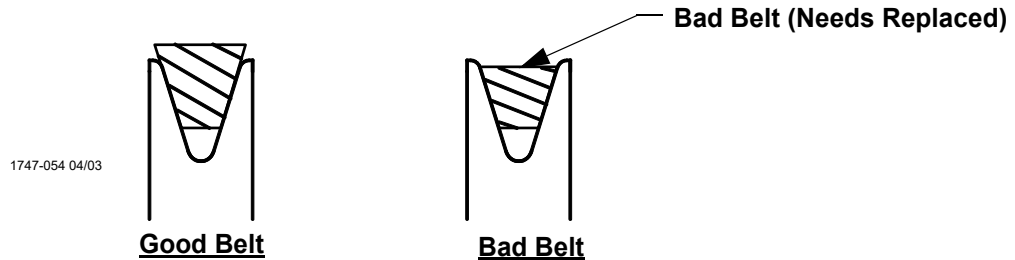

- Check Belt Tension. The Belt should be tensioned just tight enough to minimize Belt slippage. Over tensioning the belt will cause premature Belt and Bearing wear. With a new Belt the Idler Sheave indicator mark should line up with the third notch in the Tensioner Housing.

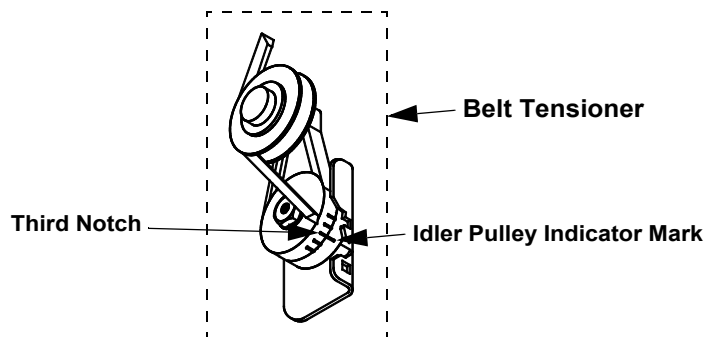

- Keep Shutters, Blades, and Housing clear of obstacles for best air performance.

- Check Sheaves for wear. Replace if a Sheave groove is worn.

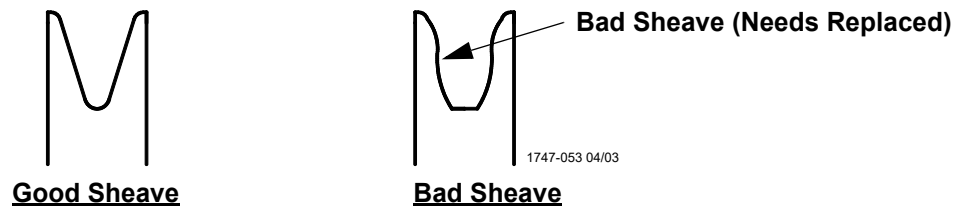

Fan Bearing and Belt Tensioner Lubrication

- Grease zerks are provided for lubrication on the fan shaft bearings and the belt tensioner.
- Lubricate the fan every 2-6 months or whenever these components get wet.
- Disconnect power to the fan before lubricating.
- Clean the zerk before lubricating to prevent contamination from entering the bearing.
- Use a high quality lithium based, NLGI #2, grease such as Shell Gadus S2 V100 2. Do not use incompatible greases containing aluminum, barium, calcium, bentonite clay or polyurea thickeners.
- Slowly rotate the fan shaft by hand while slowly applying the grease. Rapidly applying grease to a stationary bearing can damage the bearing seals.
- Apply about .10 oz (2.8 g, 3.1 cc) of grease at a time or until a slight amount of grease can be seen purging from the seal.

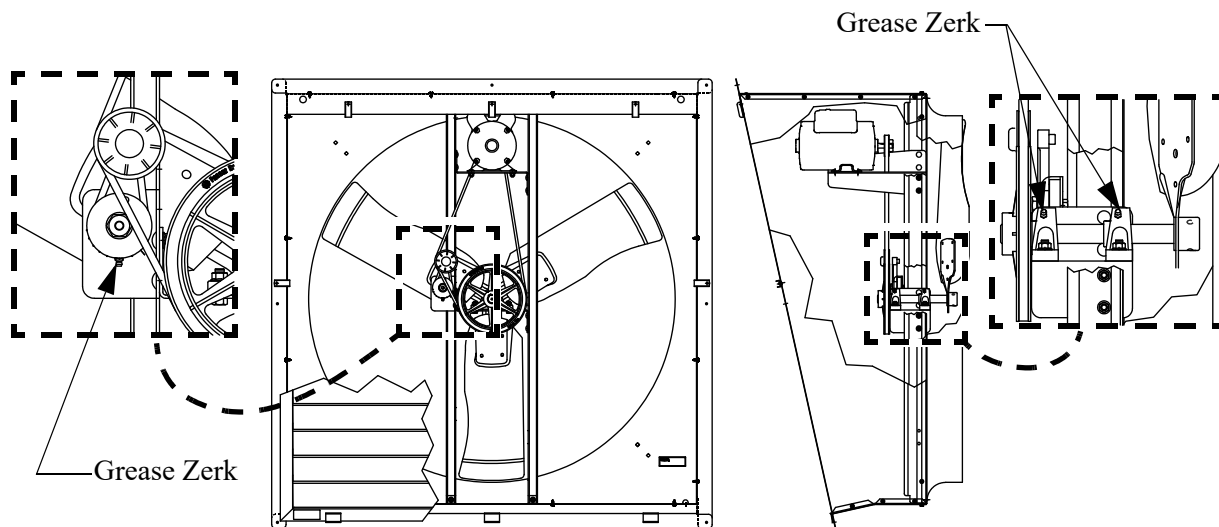

48" and 52" Itemized Parts

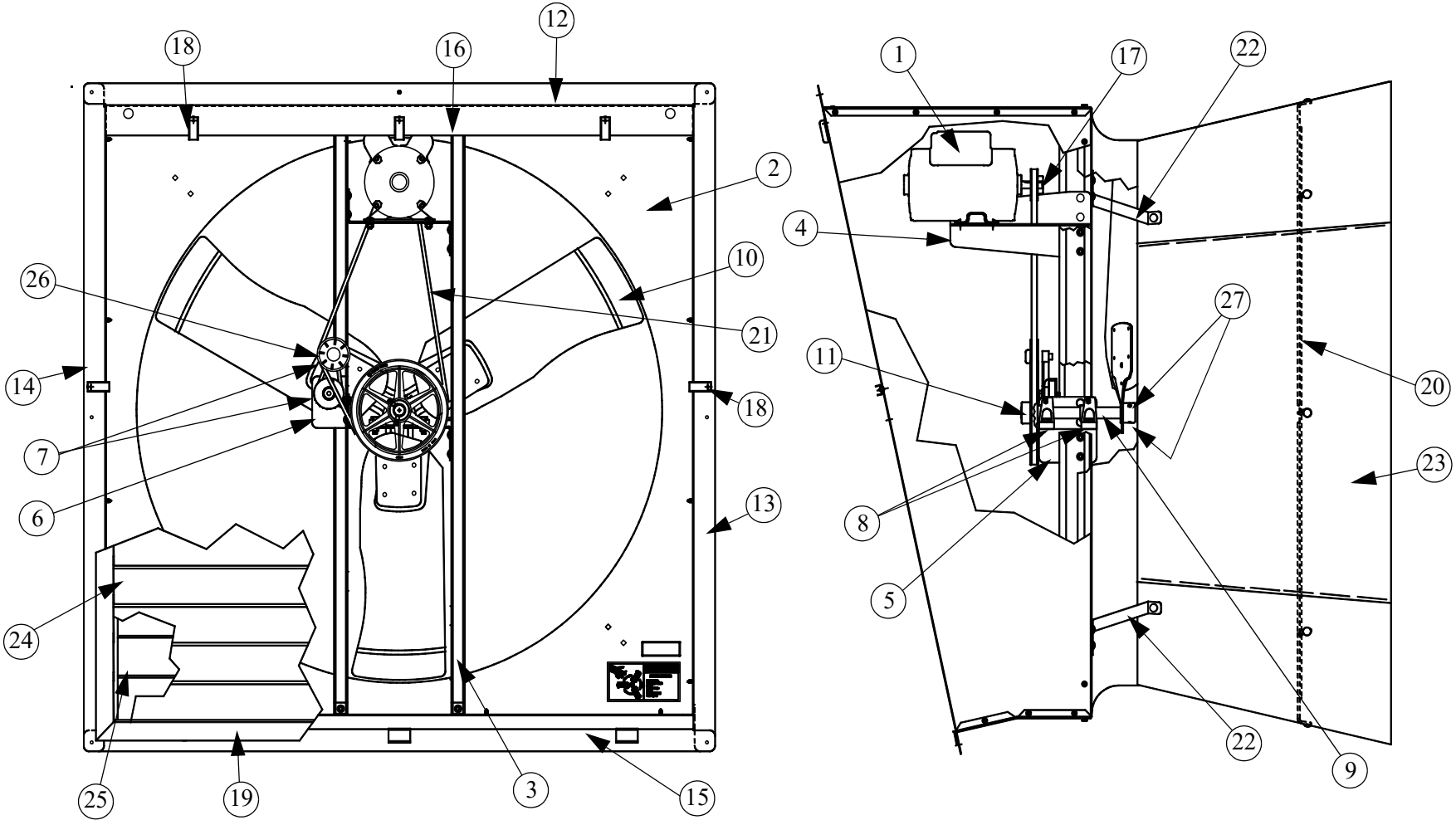

48" (48318-XXX) and 52" (48319-XXX) Part Numbers

Chore-Time Vanguard Plus Fan Components					
		48" Fans 48318-XXX		52" Fans 48319-XXX	
Item	Part Description	Part No.	Models	Part No.	Models
1	Motor, 1ph, 1.5hp, 1725 rpm	56850	-21X	56850	-22X
	Motor, 1ph, 1hp, 1725 rpm	37729	-22X, -23X		
	Motor, 3ph, 1.5hp, 1725 rpm	47693	-41X, -5XX	56850	-4XX, -52X
	Motor, 3ph, 1hp, 1725 rpm	40157	-42X		
	Motor, 1ph, 1.5hp, 1725 rpm	--	--	48580	-21X
	Motor, 1.5hp, 1.67SF 3PH-60HZ, 230/460V, 1.3SF 3PH-50/60HZ, 200-230/380-480V	--	--	56102	-51X
2	Shroud, Fan	48362	All	47710	All
3	Post, Fan	48393	All	48072	All
4	Motor Support, Idler Drive	48396	All	48396	All
5	Bearing Support, Idler Drive	48395	All	48395	All
6	Tensioner Support	48394	All	48394	All
7	Tensioner, Assy 3.5" Arm 3" Dia.	48429	All	48429	All
8	Bearing, 1" Pillow Block	50553	All	50553	All
9	Fan Shaft	48397	All	48397	All
10	Fan Blade, High Efficiency	45932	-X3X		
	Fan Blade, Standard	28140	-X2X	48507	-X2X
	Fan Blade, High Capacity	46748	-X1X	48125	-X1X
11	Sheave, Driven (AFD84100)	54898	-5XX, -23X	54898	-5XX
	Sheave, Driven (AFD94100)	54897	-21X, -22X, -4XX	54897	-2XX, -4XX
12	Housing, Top Panel	48499	All	47775	All
13	Housing, R.H. Side Panel	48501-1	All	47776-1	All
14	Housing, L.H. Side Panel	48501-2	All	47776-2	All
15	Housing, Bottom Panel	48500	All	47777	All
16	Shutter, Mounting Brace	43673	All	47774	All
17	Sheave, Driver AK27	1381	-23X		
	Sheave, Driver AK30	8773	-21X, -22X, -4XX	8773	-2XX, -4XX
	Sheave, Driver AK32	48504	-5XX	48504	-5XX
18	Shutter Clip	36729	All	36729	All
19	White Shutter Assembly w/Bell	48291	-XX5	48293	-XX5
	Gray Shutter Assembly w/Bell	48296	-XX6	48298	-XX6
20	Fan Exhaust Grill	37630	All	48475	All
21	V-Belt AX59	48615	-5XX, -23X	48615	-51X, -52X
	V-Belt AX60	48541	-21X, -22X, -4XX	48541	-21X, -41X, -22X, -42X
22	Cone Bracket	48041	All	48438	All
23	Cone Panel	48206	All	47853	All
24	Gray Shutter Louver	46715-4	-XX6	46715-6	-XX6
	White Shutter Louver	38038-4	-XX5	38038-13	-XX5
25	Shutter Louver Rod	38702-4	All	38702-12	All
26	Idler Pulley (For Repair)	50879	All	50879	All
27	5/16-24 x 1" HXHD Bolt			--	All
	5/16-24 x 1" SQHD Bolt	--	All		

Safety Information

Carefully read all safety messages in this manual and on your equipment safety signs. Follow recommended precautions and safe operating practices. Keep safety signs in good condition. Replace missing or damaged safety signs.

DANGER: Electrical Hazard

Disconnect electrical power before inspecting or servicing equipment unless maintenance instructions specifically state otherwise. Ground all electrical equipment for safety. All electrical wiring must be done by a qualified electrician in accordance with local and national electric codes. Ground all non-current carrying metal parts to guard against electrical shock. With the exception of motor overload protection, electrical disconnects and over current protection are not supplied with the equipment.



DANGER: Rotating Fan Blade

Keep Hands away. Disconnect power before servicing. Fan may start automatically. Do not operate the Fan without the screens in place. Disregard to these things will cause serious injury including death.



Warranty Information

CTB, Inc., (“Chore-Time”), warrants each new CHORE-TIME® product manufactured by it to be free from defects in material or workmanship for one (1) year from and after the date of initial installation by or for the original purchaser. If such a defect is found by Chore-Time to exist within the one-year period, Chore-Time will, at its option, (a) repair or replace such product free of charge, F.O.B. the factory of manufacture, or (b) refund to the original purchaser the original purchase price, in lieu of such repair or replacement. Labor costs associated with the replacement or repair of the product are not covered by the Manufacturer.

Conditions and Limitations

1. The product must be installed by and operated in accordance with the instructions published by the **Manufacturer or Warranty will be void.**
2. Warranty is void if **all components** of the system are not original equipment supplied by the **Manufacturer.**
3. This product must be purchased from and installed by an authorized distributor or certified representative thereof or the Warranty will be void.
4. "Malfunctions or failure resulting from misuse, abuse, mismanagement, negligence, alteration, accident, or lack of proper maintenance, or from lightning strikes, electrical power surges or interruption of electricity shall not be considered defects under the Warranty. Corrosion, material deterioration and/or equipment malfunction caused by or consistent with excessive additions or application of chemicals, minerals, sediments or other foreign elements with the product shall not be considered defects under the Warranty."
5. This Warranty applies only to systems for the care of poultry and livestock. Other applications in industry or commerce are not covered by this Warranty.

Chore-Time shall not be liable for any **Consequential or Special Damage** which any purchaser may suffer or claim to suffer as a result of any defect in the product. **“Consequential” or “Special Damages” as used herein include, but are not limited to, lost or damaged products or goods, costs of transportation, lost sales, lost orders, lost income, increased overhead, labor and incidental costs and operational inefficiencies.**

THIS WARRANTY CONSTITUTES THE MANUFACTURER’S ENTIRE AND SOLE WARRANTY AND THIS MANUFACTURER DISCLAIMS ANY AND ALL OTHER WARRANTIES, INCLUDING, BUT NOT LIMITED TO, EXPRESS AND IMPLIED WARRANTIES AS TO MERCHANTABILITY, FITNESS FOR PARTICULAR PURPOSES SOLD AND DESCRIPTION OR QUALITY OF THE PRODUCT FURNISHED HEREUNDER.

Chore-Time Distributors are not authorized to modify or extend the terms and conditions of this Warranty in any manner or to offer or grant any other warranties for CHORE-TIME® products in addition to those terms expressly stated above. An officer of CTB, Inc. must authorize any exceptions to this Warranty in writing. Chore-Time reserves the right to change models and specifications at any time without notice or obligation to improve previous models.

Revisions to this Manual

Page No.	Description of Change	ECO
9	Changed 48312 to 48041	36121

Obsoleted A59 and A60 Belts
 CTB, Inc.
 PO Box 2000
 Milford, Indiana 46542-2000 USA
 Phone (574) 658-4101 Fax (877) 730-8825
 Email: choretime@choretime.com
 Internet: www.choretime.com