

Konavi® Pullet Feeding System

Installation and Operators Manual

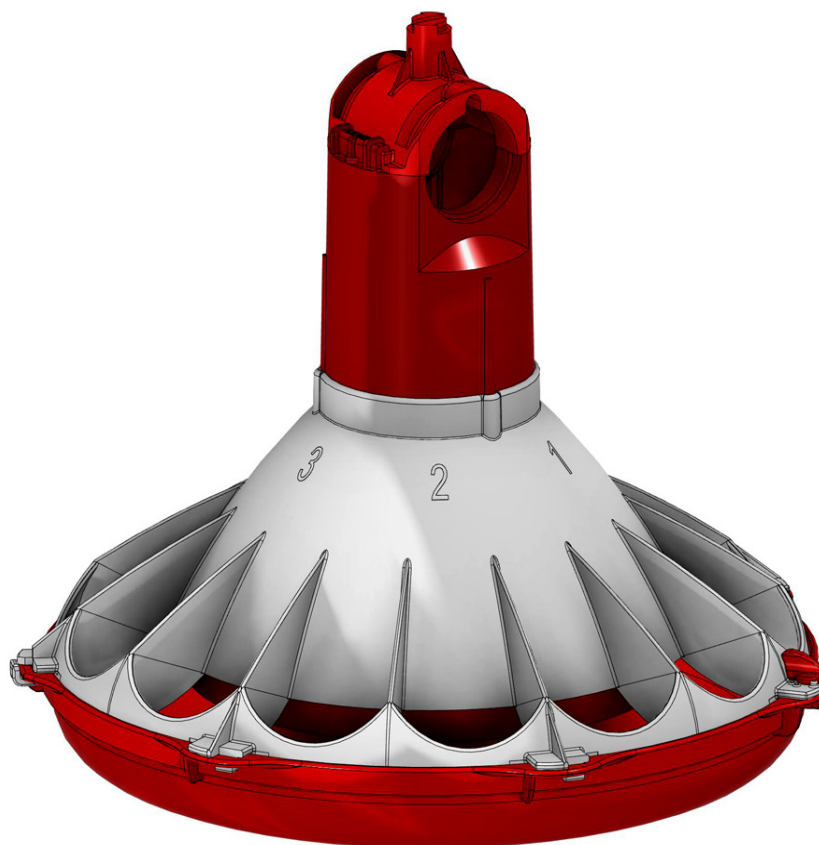

For additional parts and information, contact your nearest Chore-Time distributor or representative.
Find your nearest distributor at: www.choretime.com/contacts

Installation and Operators Manual

Installation and Operators Manual

Contents

Topic	Page
Introduction	4
General.....	4
Support Information.....	4
Safety.....	5
Safety–Alert Symbol.....	5
Understanding Signal Words.....	5
Follow Safety Instructions.....	5
Decal Descriptions.....	5
Limited Warranty.....	6
Planning	7
Manufacturer’s Recommendations: Birds per Pan.....	7
Planning the Suspension System.....	8
Laying out the Suspension System.....	9
Systems over 350’ [107 m].....	9
Systems up to 350’ [107 m].....	10
Installation	11
Power Lift Winch Installation.....	11
Power Lift Winch Support (Steel or Wood).....	11
Attaching Winch Support to Trusses.....	12
Cable Installation.....	13
Special Support at Hopper Locations (Wood Construction).....	13
Special Support at Hopper Location (Steel Truss).....	13
Support at Power Unit Location.....	14
Attaching the Main Winch Cable (Temporarily).....	15
Cable Routing at Winch.....	15
Wrapping Cable on Winch Drum.....	15
Screw Hook Installation.....	16
Ceiling Hook Installation.....	16
Drop Installation.....	17
Throwback Cable Arrangement.....	17
Hopper Suspension.....	17
Assembling Feeder	18
Feeder Line Assembly and Suspension.....	20
Installing Feeders on the Feeder Tube.....	20
Assembling and Suspending the Feeder Tubes.....	21
Installing Adjustable Hangers.....	22
Suspending the Feeder Line.....	23
Indexing Chart for Pullet Feeders.....	25
Systems using 10’ (3 m) Feeder Tube.....	25
Installing the End Control and Boot Assembly.....	26
Auger/End Control Installation.....	27
Auger Stretch.....	30
Auger Brazing.....	31
Mid-Line Control.....	32
Location/Planning.....	32
Installation.....	32
Attaching the Mid-Line Control.....	33
Anti-Roost Assembly.....	34
Wiring.....	36
End Control with Proximity Switch Internal Wiring.....	36
Proximity Sensor Wiring Diagram.....	36

Contents - continued

Topic	Page
Mid-Line Control with Proximity Sensor Internal Wiring	36
Electronic Sensor Three Phase Wiring	37
Power Unit Wiring	38
Troubleshooting	39
Maintenance	40
Floor Feeding System Maintenance	40
Gear Head Maintenance	40
Proximity Sensor Adjustment	41
Feeder Line	42
Power Lift Winch Maintenance	42
Operation	43
Initial Start-up of the Feeding System	43
To operate	43
General Operation of the KONAVI® Pullet Feeders	43
Feeder Pan Setting	44
Feed Volume	44
End Control Pans	44
Mid Line Control Pan	44
Electro-guard Operation	44
Parts List	45
150# Plastic Hopper (49268)	45
8798 Switch Assembly	46
200# Hopper Components	47
100 # Hopper Components	48
Hopper Mount Bracket	49
Single Boot Components Part No. 6822	49
Twin Boot Components Part No. 6824	50
Feeder Tubes	50
Feeder Line Components	51
KONAVI® Breeder Feeder Assembly (Part Number 57452)	52
Power Winch (Part No. 47687)	52
Power Unit Assemblies	53
Power Unit Assembly Part Numbers	53
8798 Switch Assembly	54
14485 Anti-Swing Clamp Kit	55
KONAVI® Proximity Sensor End Control 57425	56
KONAVI® 57453 Proximity Sensor Mid Line Control	58
Miscellaneous Suspension Components	60

Introduction

The intent of this manual is to help you in two ways. One is to follow step-by-step in the order of assembly of your product. The other way is for easy reference if you have questions in a particular area.

Important: Read ALL instructions carefully before starting construction.

Important: Pay particular attention to all SAFETY information.

- *Metric measurements are shown in millimeters and in brackets, unless otherwise specified. “” equals inches and “” equals feet in English measurements.*

Examples:

1" [25.4]

4' [1219]

- Optional equipment contains necessary instructions for assembly or operation.
- Very small numbers near an illustration (*i.e.*, 1257-48) are identification of the graphic, not a part number.

General

Support Information

The Chore-Time Indexed Pullet Feeding System is designed to provide feed poultry. Using this equipment for any other purpose or in a way not within the operating recommendations specified in this manual will void the warranty and may cause personal injury.

This manual is designed to provide comprehensive planning and installation information. The Table of Contents provides a convenient overview of the information in this manual

Note: The original, authoritative version of this manual is the English version produced by CTB, Inc. or any of its subsidiaries or divisions, (hereafter collectively referred to as "CTB"). Subsequent changes to any manual made by any third party have not been reviewed nor authenticated by CTB. Such changes may include, but are not limited to, translation into languages other than English, and additions to or deletions from the original content. CTB disclaims responsibility for any and all damages, injuries, warranty claims and/or any other claims associated with such changes, inasmuch as such changes result in content that is different from the authoritative CTB-published English version of the manual. For current product installation and operation information, please contact the customer service and/or technical service departments of the appropriate CTB subsidiary or division. Should you observe any questionable content in any manual, please notify CTB immediately in writing to: CTB Legal Department, P.O. Box 2000, Milford, IN 46542-2000 USA.

Safety

Caution, Warning, and Danger Decals have been placed on the equipment to warn of potentially dangerous situations. Care should be taken to keep this information intact and easy to read at all times. Replace missing or damaged safety decals immediately.

Safety–Alert Symbol



This is a safety–alert symbol. When you see this symbol on your equipment, be alert to the potential for personal injury. This equipment is designed to be installed and operated as safely as possible...however, hazards do exist.

Understanding Signal Words

Signal words are used in conjunction with the safety–alert symbol to identify the severity of the warning.



DANGER—Indicates an imminently hazardous situation which, if not avoided, **WILL** result in death or serious injury.



WARNING—Indicates a potentially hazardous situation which, if not avoided, **COULD** result in death or serious injury.



CAUTION—Indicates a hazardous situation which, if not avoided, **MAY** result in minor or moderate injury.

Follow Safety Instructions

Carefully read all safety messages in this manual and on your equipment safety signs. Follow recommended precautions and safe operating practices.

Keep safety signs in good condition. Replace missing or damaged safety signs.

Decal Descriptions

DANGER: Moving Auger

This decal is placed on the End Cap Weldment and Clean-out cover. Severe personal injury will result, if the electrical power is not disconnected, prior to servicing the equipment.



DANGER: Electrical Hazard

- Disconnect electrical power before inspecting or servicing equipment unless maintenance instructions specifically state otherwise.

- Ground all electrical equipment for safety.

- All electrical wiring must be done by a qualified electrician in accordance with local and national electric codes.

- Ground all non-current carrying metal parts to guard against electrical shock.

- Electrical disconnects and over current protection are not supplied with the equipment.

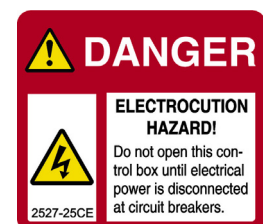

DANGER: Springing Auger

Use caution when working with Auger. Springing Auger may cause personal injury.

Attention: Read the Manual

See the manual for detailed installation instructions.

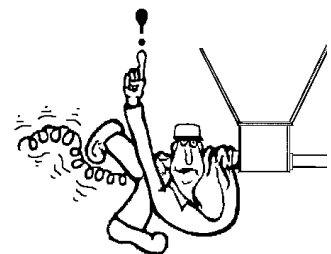

Limited Warranty

Chore-Time Group, a division of CTB, Inc. (“Chore-Time”) warrants the new CHORE-TIME Indexed Pullet Feeding products manufactured by Chore-Time to be free from defects in material or workmanship under normal usage and conditions, for One (1) year from the date of installation by the original purchaser (“Warranty”). Chore-Time provides for an extension of the aforementioned Warranty period (“Extended Warranty Period”) with respect to certain Product parts (“Component Part”) as set forth in the table below. If such a defect is determined by Chore-Time to exist within the applicable period, Chore-Time will, at its option, (a) repair the Product or Component Part free of charge, F.O.B. the factory of manufacture or (b) replace the Product or Component Part free of charge, F.O.B. the factory of manufacture. This Warranty is not transferable, and applies only to the original purchaser of the Product.

Component Part	Extended Warranty Period
RXL Fan (except motors and bearings)	Three (3) Years
TURBO® Fan (except motors and bearings)	Three (3) Years
TURBO® Fan fiberglass housing, polyethylene cone, and cast aluminum blade.	Lifetime of Product
TURBO® fan motor and bearings.	Two (2) Years
Chore-Time® Poultry Feeder Pan	Three (3) Years
Chore-Time® Rotating Centerless Augers (except where used in applications involving high moisture feed stuffs exceeding 17%)	Ten (10) Years
Chore-Time Steel Auger Tubes	Ten (10) Years
ULTRAFLO® Breeder Feeding System auger and feed trough.	Five (5) Years
ULTRAPAN® Feeding System augers.	Five (5) Years

CONDITIONS AND LIMITATIONS

THIS WARRANTY CONSTITUTES CHORE-TIME’S ENTIRE AND SOLE WARRANTY AND CHORE-TIME EXPRESSLY DISCLAIMS ANY AND ALL OTHER WARRANTIES, INCLUDING, BUT NOT LIMITED TO, EXPRESS AND IMPLIED WARRANTIES, INCLUDING, WITHOUT LIMITATION, WARRANTIES AS TO MERCHANTABILITY OR FITNESS FOR PARTICULAR PURPOSES. CHORE-TIME shall not be liable for any direct, indirect, incidental, consequential or special damages which any purchaser may suffer or claim to suffer as a result of any defect in the Product. Consequential or Special Damages as used herein include, but are not limited to, lost or damaged products or goods, costs of transportation, lost sales, lost orders, lost income, increased overhead, labor and incidental costs, and operational inefficiencies. *Some jurisdictions prohibit limitations on implied warranties and/or the exclusion or limitation of such damages, so these limitations and exclusions may not apply to you. This warranty gives the original purchaser specific legal rights. You may also have other rights based upon your specific jurisdiction.*

Compliance with federal, state and local rules which apply to the location, installation and use of the Product are the responsibility of the original purchaser, and CHORE-TIME shall not be liable for any damages which may result from non-compliance with such rules.

The following circumstances shall render this Warranty void:

- Modifications made to the Product not specifically delineated in the Product manual.
- Product not installed and/or operated in accordance with the instructions published by the CHORE-TIME.
- All components of the Product are not original equipment supplied by CHORE-TIME.
- Product was not purchased from and/or installed by a CHORE-TIME authorized distributor or certified representative.
- Product experienced malfunction or failure resulting from misuse, abuse, mismanagement, negligence, alteration, accident, or lack of proper maintenance, or from lightning strikes, electrical power surges or interruption of electricity.
- Product experienced corrosion, material deterioration and/or equipment malfunction caused by or consistent with the application of chemicals, minerals, sediments or other foreign elements.
- Product was used for any purpose other than for the care of poultry and livestock.

The Warranty and Extended Warranty may only be modified in writing by an officer of CHORE-TIME. CHORE-TIME shall have no obligation or responsibility for any representations or warranties made by or on behalf of any distributor, dealer, agent or certified representative.

Effective: **April, 2014**

Planning

Manufacturer's Recommendations: Birds per Pan

Max weight and/or weeks of age	Number of birds/pan
0-18 weeks	14-15
0-18 weeks Hi-Yield	12-14

***Notice:** Please be advised that the maximum number of birds that may be successfully produced per feed pan may vary based upon such factors as climate, housing type or style, bird breeds, genetic factors of the birds at issue, grower management practices, etc. All other environmental and management circumstances, such as proper bird density per house, access to adequate nutrients in feed, access to adequate water supply, proper ventilation, adequate health care for the birds, and other similar factors, must meet industry standards and recommendations, if any, of applicable bird breeder companies.

*** NOTICE:** The above Manufacturer's recommendations do not constitute a product warranty and are in no way to be considered as a guarantee of performance for poultry production. In addition, the above information in no way alters or revises the terms and conditions of any applicable Chore-Time manufacturer's warranty.

Planning the Suspension System

Systems with line lengths over 300' [91 m] should be split in the center, as shown in **Figure 1**. This will reduce auger running time and eliminate the need for Mid-Line Controls for partial house brooding.

Center Fill is recommended. 1/4 house brooding can be accomplished by using only two feed lines when chicks are placed. This is the recommended method.

If Mid-Line Controls are used for 1/4 house brooding, **DO NOT** index the Feed Tubes that include Mid-Line Controls.

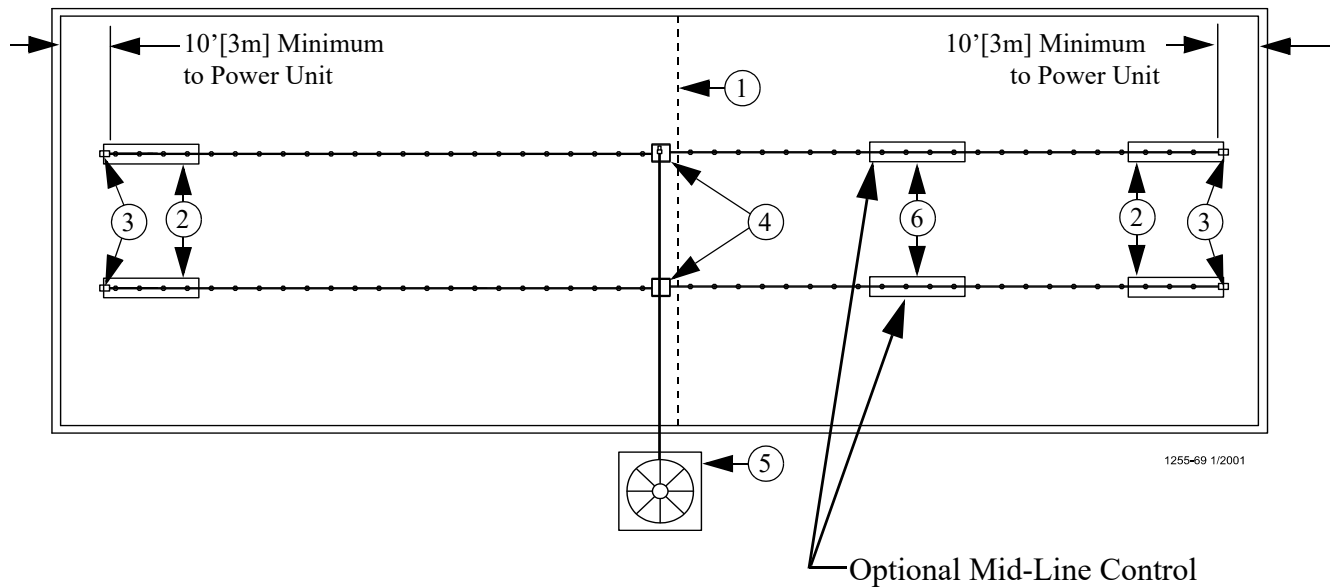

Item	Description
1	Brood Curtain
2	Control Tube
3	End Control and Power Unit
4	Feeder Hopper
5	Feed Bin
6	Optional Mid-Line Control

Figure 1. Component location diagram

◦ Laying out the Suspension System

Systems over 350' [107 m]

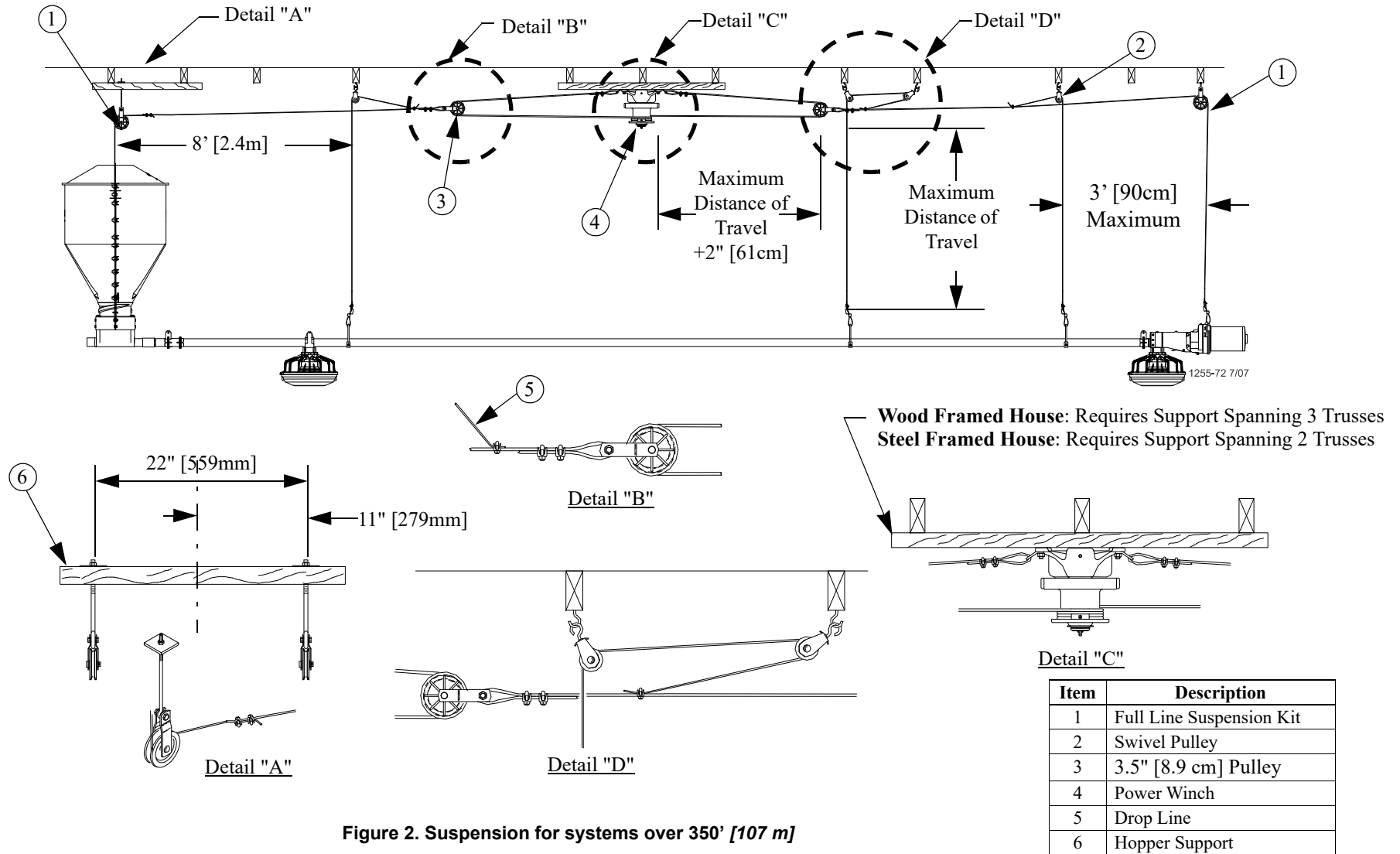
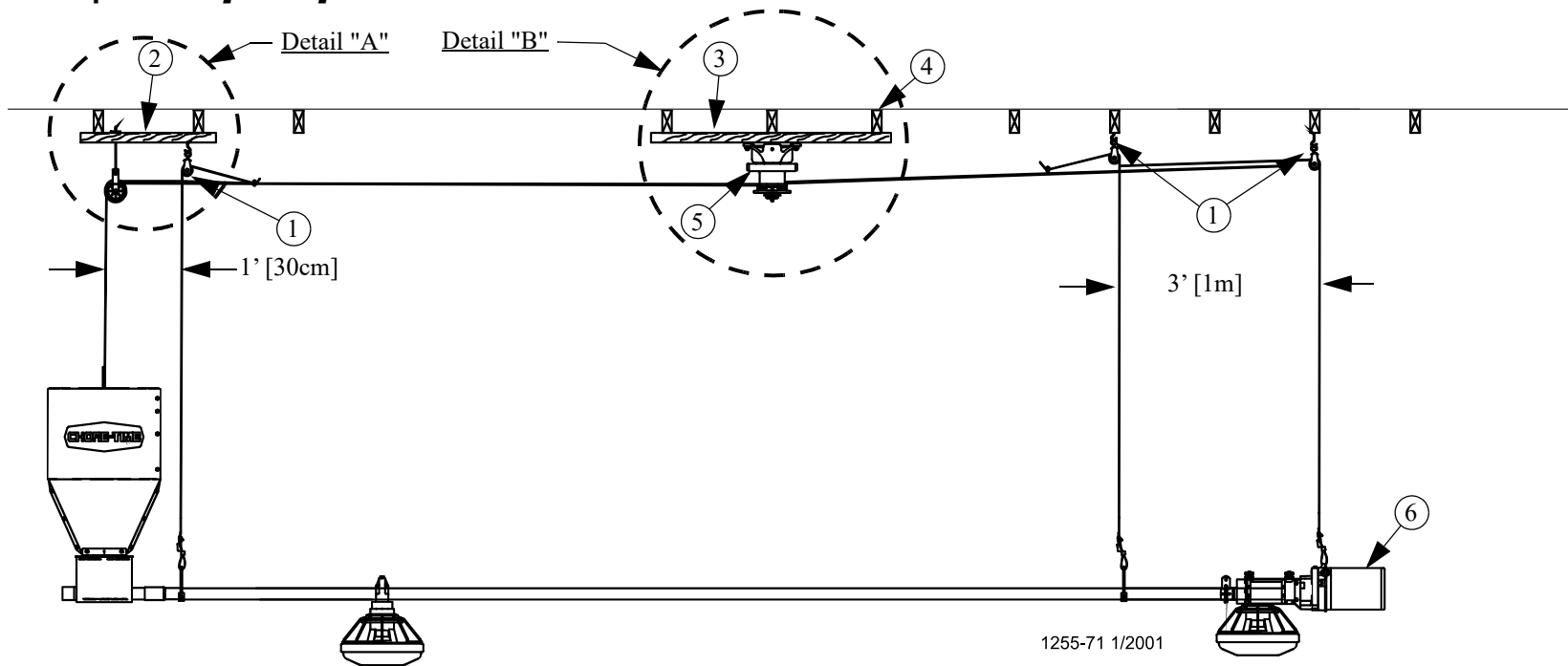
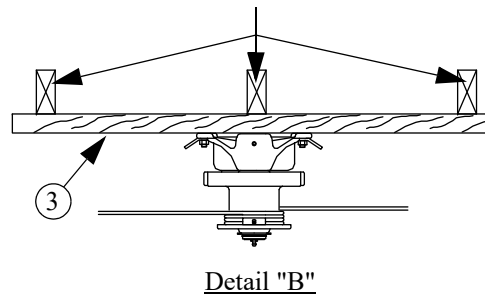
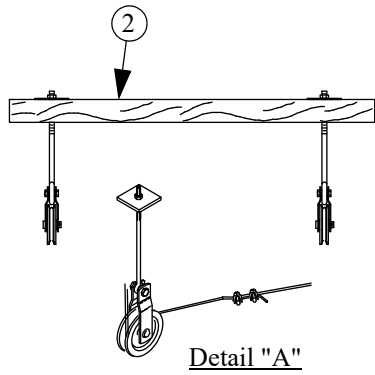

Figure 2. Suspension for systems over 350' [107 m]

Systems up to 350' [107 m]



Wood Framed House: Requires Support Spanning 3 Trusses
Steel Framed House: Requires Support Spanning 2 Trusses



Item	Description
1	Swivel Pulley
2	Hopper Support
3	Winch Support
4	Roof Truss
5	Winch
6	Power Unit

Figure 3. Suspension for systems up to 350' [107 m]

Installation

Power Lift Winch Installation

Power Lift Winch Support (Steel or Wood)

Wood Truss Installation

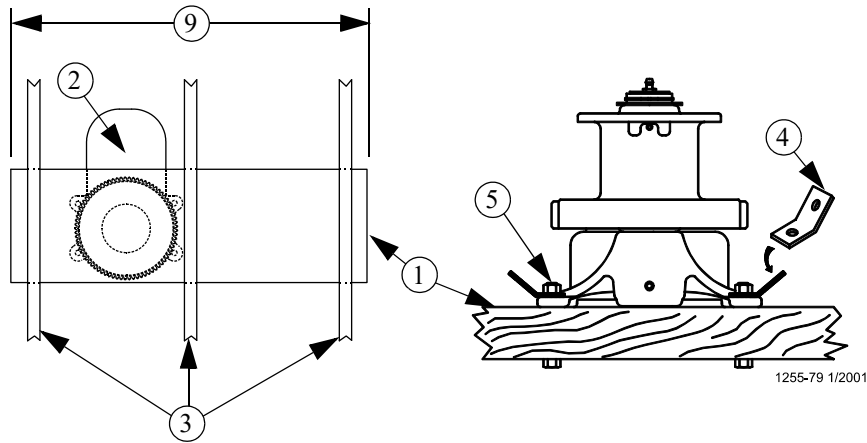

Steel Truss Installation

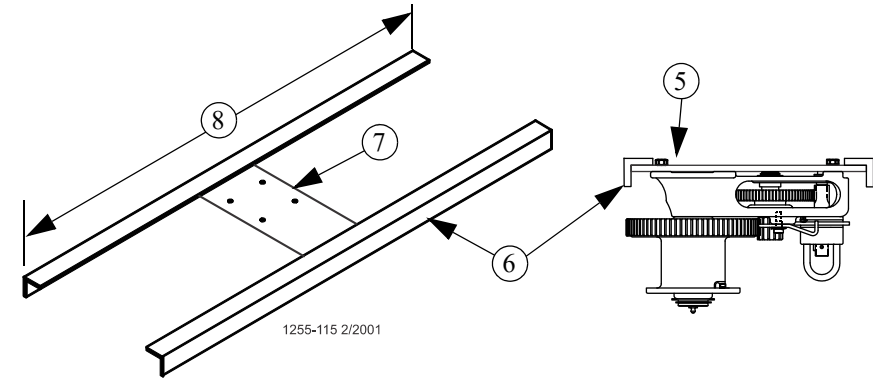

Item	Description
1	Power Lift Winch Support: 2" x 8" [50 x 200 mm] board spanning at least 3 trusses .
2	Power Lift Winch
3	Truss
4	Cable Hook: Install as shown.
5	5/16-18 Bolt, Washer, and Locknut (In parts package)
6	Angle Iron: Long enough to span 2 Trusses .
7	3/8" [9.5mm] Thick Steel Mounting Plate
8	Long enough to span 2 Trusses
9	Long enough to span 3 Trusses

Figure 4. Power Lift Winch Support

Attaching Winch Support to Trusses

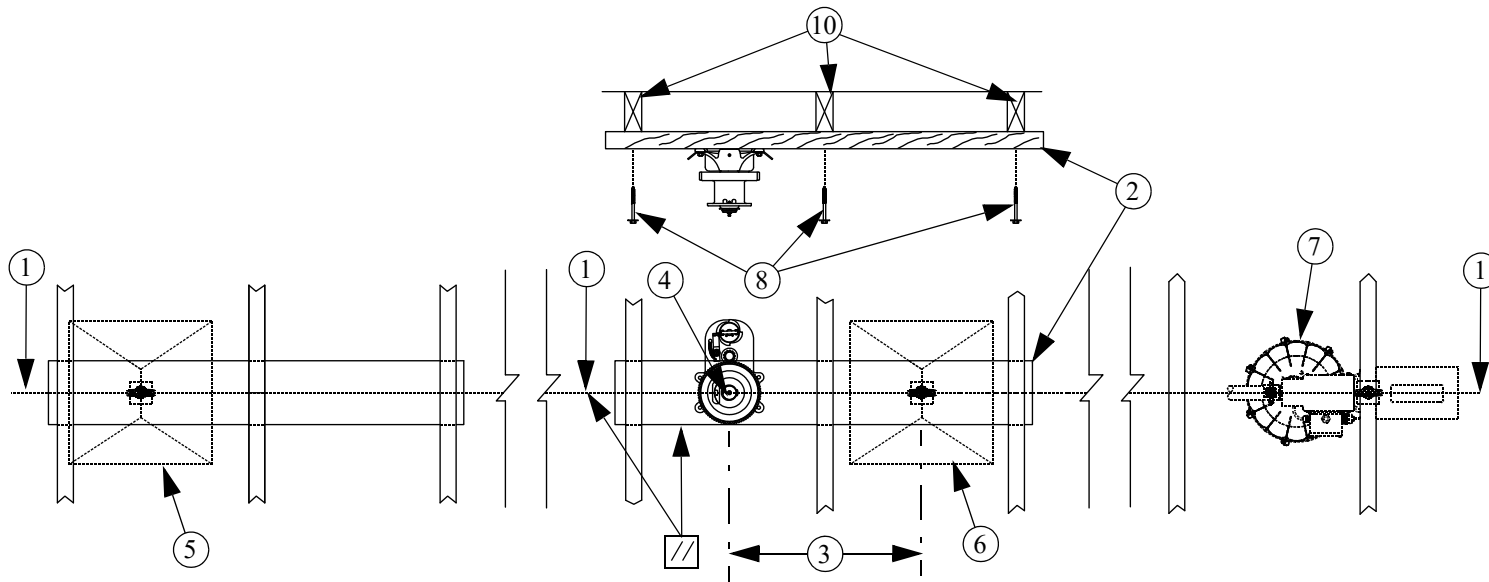

Wood Truss Installation

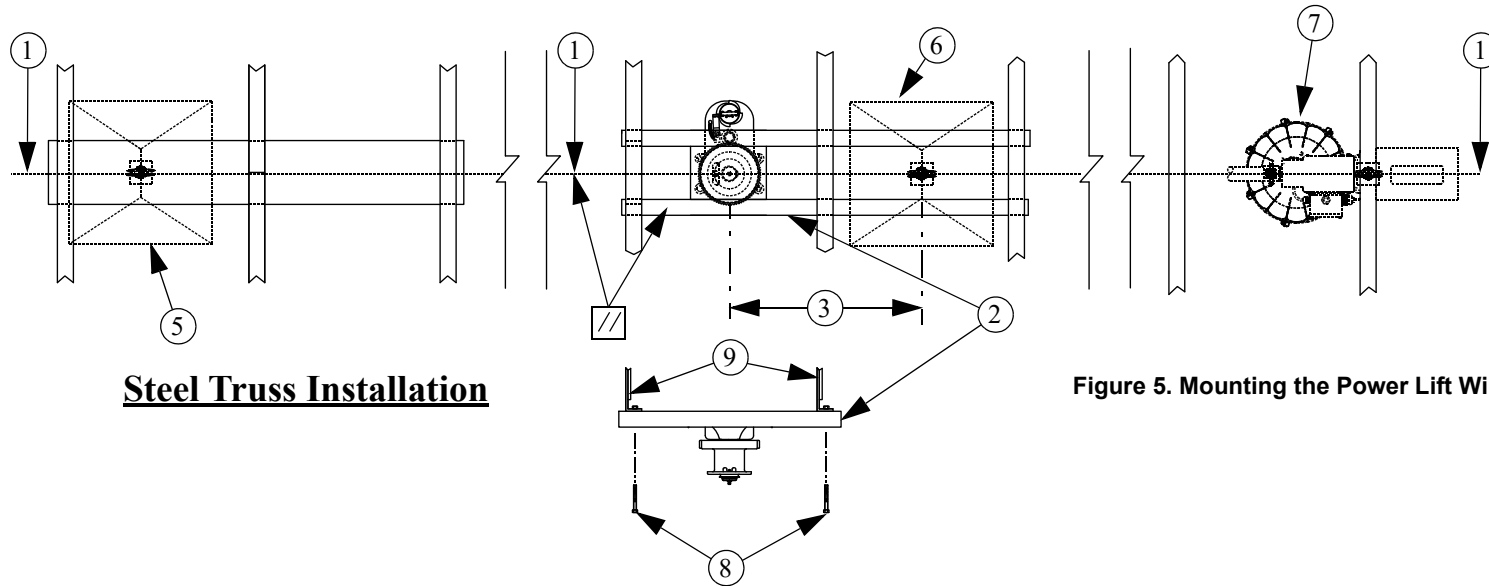

Steel Truss Installation

Item	Description
1	Feeder Line
2	Winch & Winch Support
3	Winch Centered on Feeder line unless Feed Hopper is centered.
4	Winch Centered directly over Feeder Line
5	Hopper (End of Feed line option)
6	Hopper (Center of Feed line option)
7	End Control
8	Lag Bolts
9	Steel Truss
10	Wood Truss

Figure 5. Mounting the Power Lift Winch and Support to Trusses

Cable Installation

Important! Special Support Required at Hopper Location if the Hopper is not directly under a Truss.

Special Support at Hopper Locations (Wood Construction)

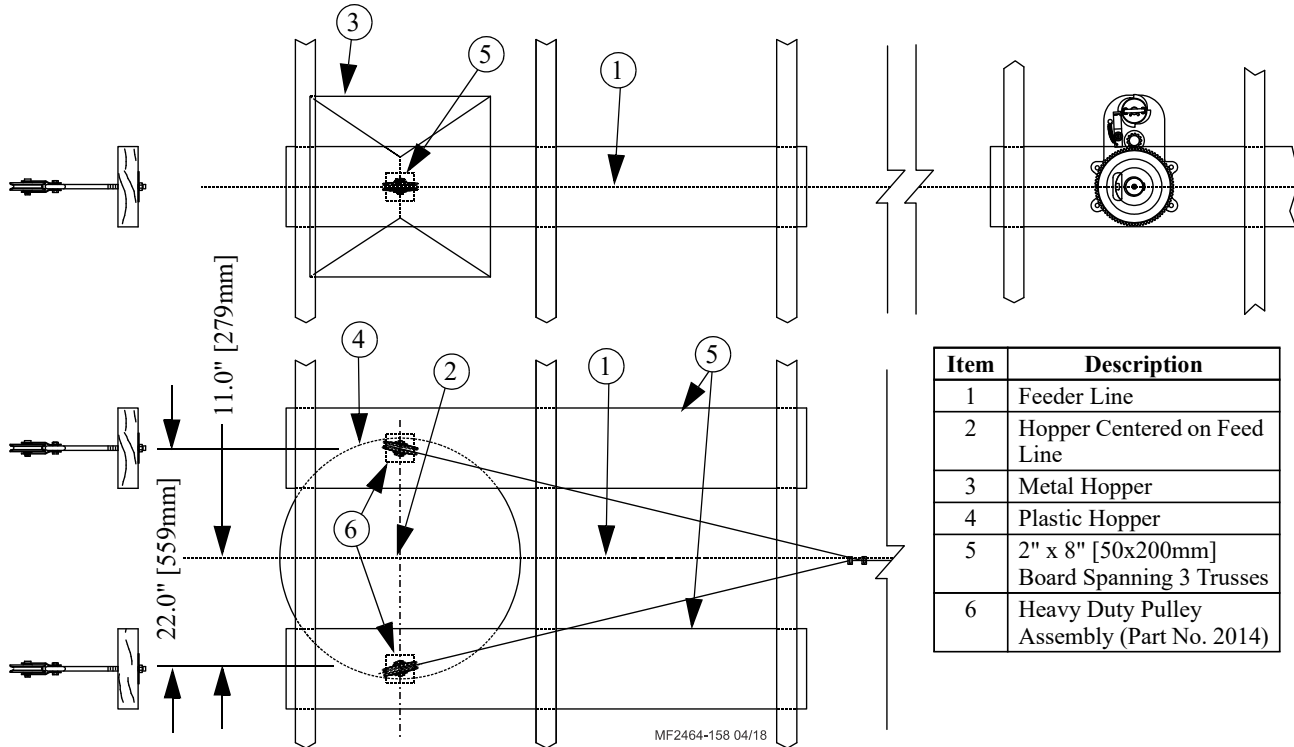

Figure 6. Cable Installations at Hopper Locations (Wood Construction)

Special Support at Hopper Location (Steel Truss)

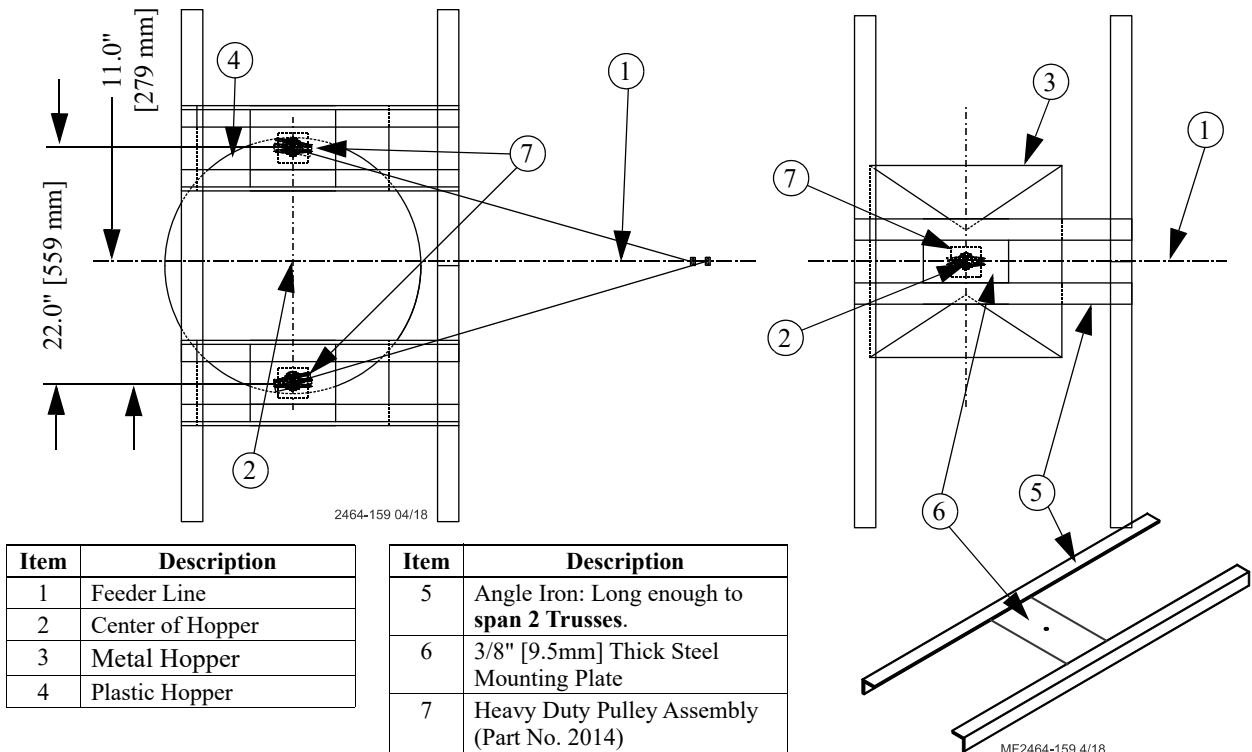
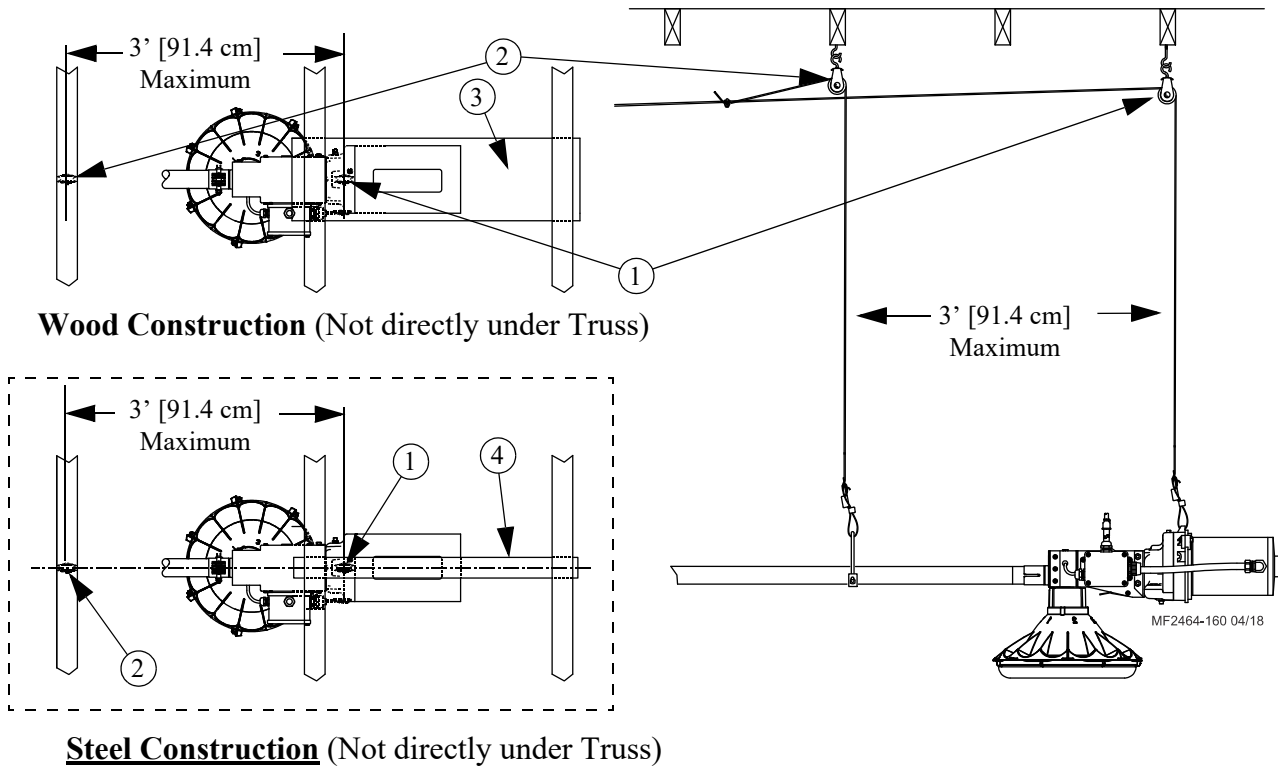

Figure 7. Special Support at Hopper Location (Steel)

Support at Power Unit Location



Item	Description
1	Power Unit Drop Pulley
2	1st Feed Line Drop Pulley
3	2" x 8" [50x200mm] Board long enough to Span 2 Trusses and support 75 lbs. [34kg]
4	Angle Iron: Long enough to span 2 Trusses and Support 75 lbs. [34kg]

Figure 8.Support at Power Unit

Attaching the Main Winch Cable (Temporarily)

Plan for a Double-Back Pulley arrangement if over 350' [107m] (See Figure 9.)

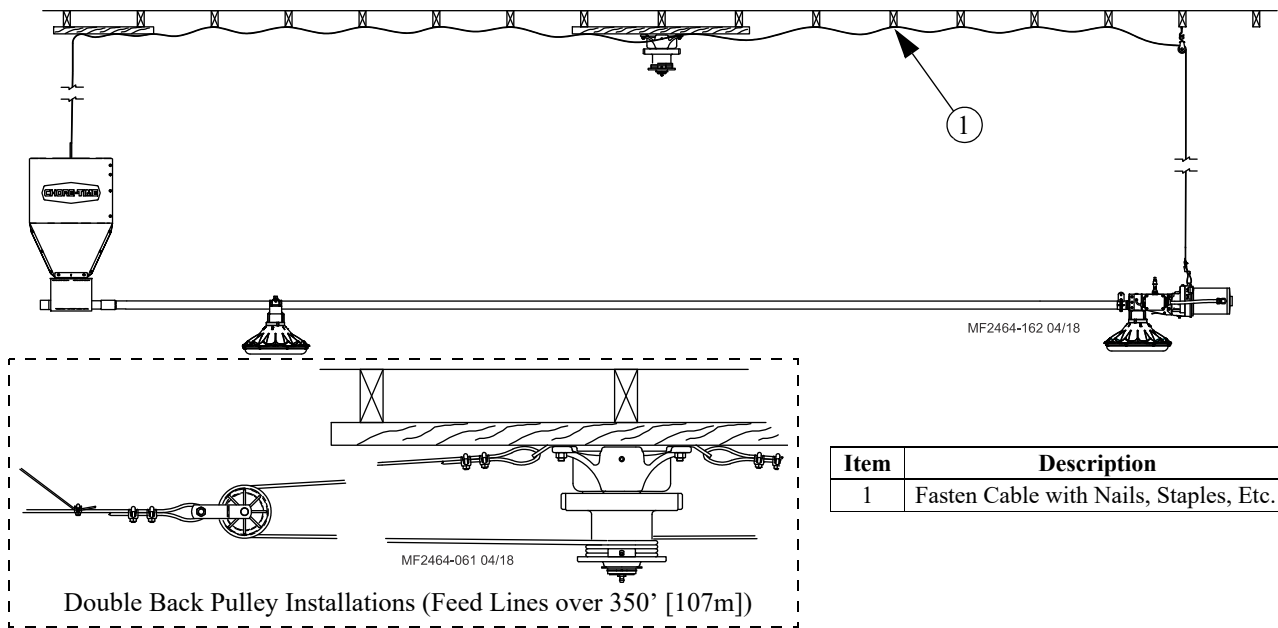

Item	Description
1	Fasten Cable with Nails, Staples, Etc.

Figure 9. Temporarily Attaching Main Winch Cable to Ceiling

Cable Routing at Winch

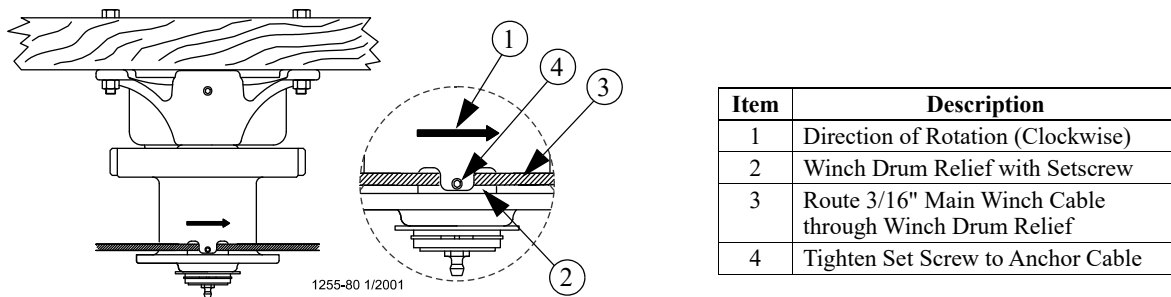

Item	Description
1	Direction of Rotation (Clockwise)
2	Winch Drum Relief with Setscrew
3	Route 3/16" Main Winch Cable through Winch Drum Relief
4	Tighten Set Screw to Anchor Cable

Figure 10. Winch Cable Routing

Wrapping Cable on Winch Drum

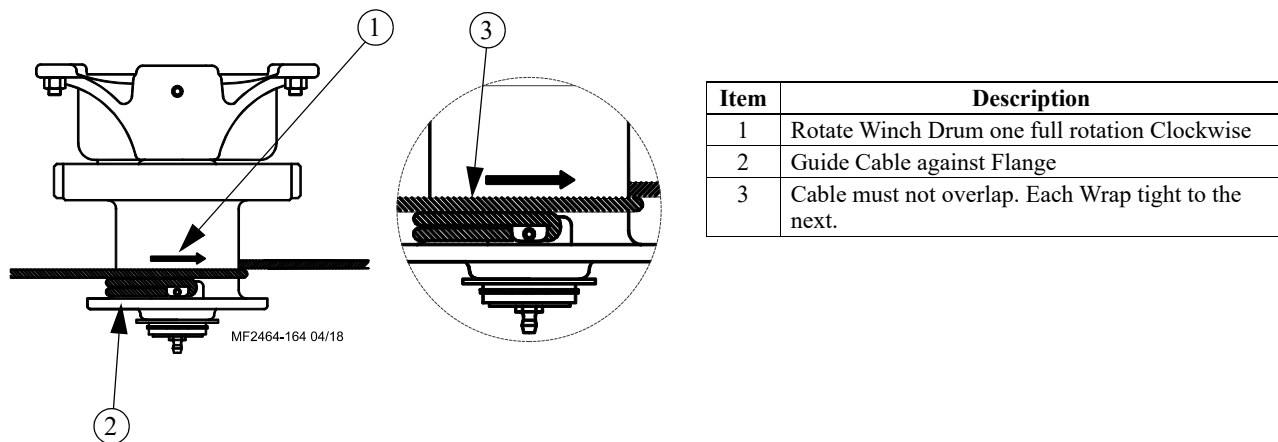

Item	Description
1	Rotate Winch Drum one full rotation Clockwise
2	Guide Cable against Flange
3	Cable must not overlap. Each Wrap tight to the next.

Figure 11. Wrapping Cable on Winch Drum

Screw Hook Installation

If distance raised (3) is greater than (2) then stagger Screw hooks (4) as shown.

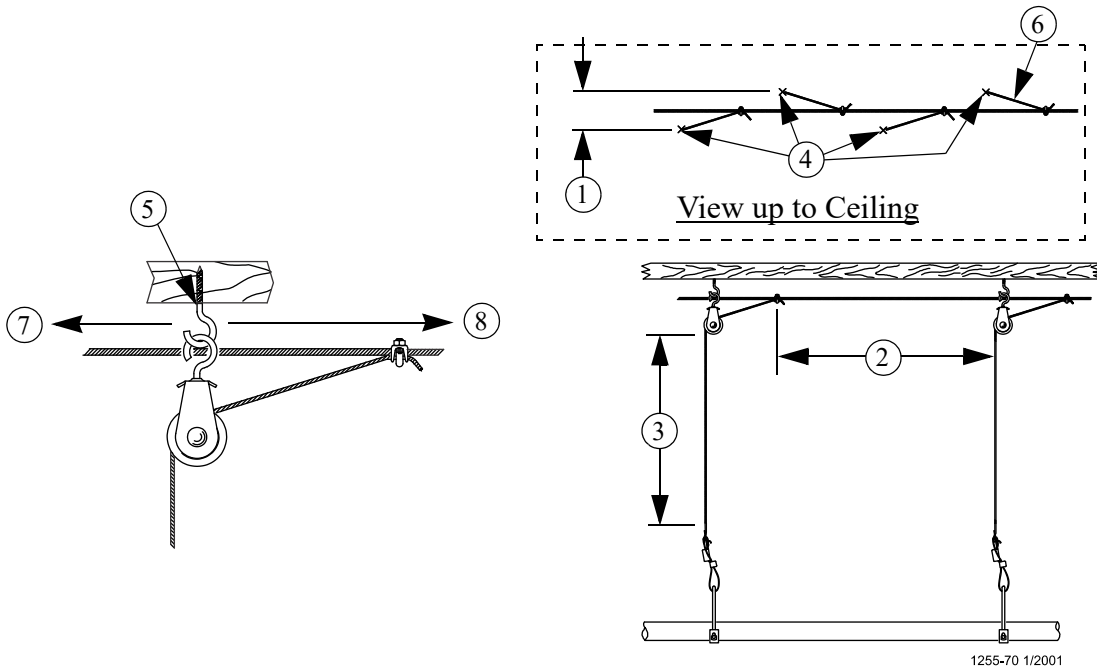

1255-70 1/2001

Item	Description	Part No.
1	3" [7.6 cm] Offset	
2	Distance of Cable Travel (Recommended 8' [2.4m] on center). Do Not exceed 10' [3m].	
3	Distance Feeder is to be raised	
4	Screw Hook (Stagger as shown if (3) is greater than (2))	
5	Screw in Screw Hook full length of threads.	2041
6	3/32 [2mm] Drop Cable	
7	Screw Hook Opening facing opposite direction of travel.	
8	Winch End (Direction of Travel).	

Figure 12.Screw Hook Installation

Ceiling Hook Installation

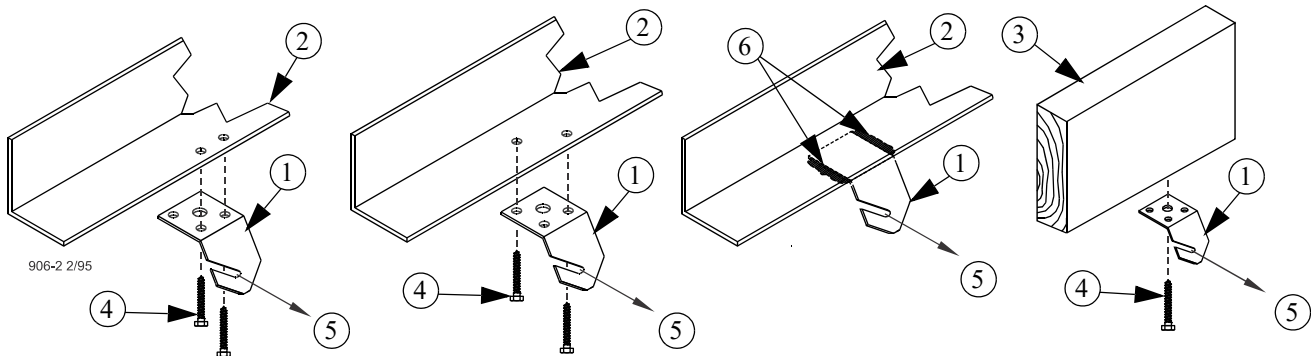

906-2 2/95

Item	Description	Part No.
1	Ceiling Hook	28550
2	Steel Truss	--
3	Wood Truss	
4	1/4-20 Lag Screw	--
5	Cable Travel Direction	--
6	Weld	--

Figure 13.Ceiling Hook Installation

Drop Installation

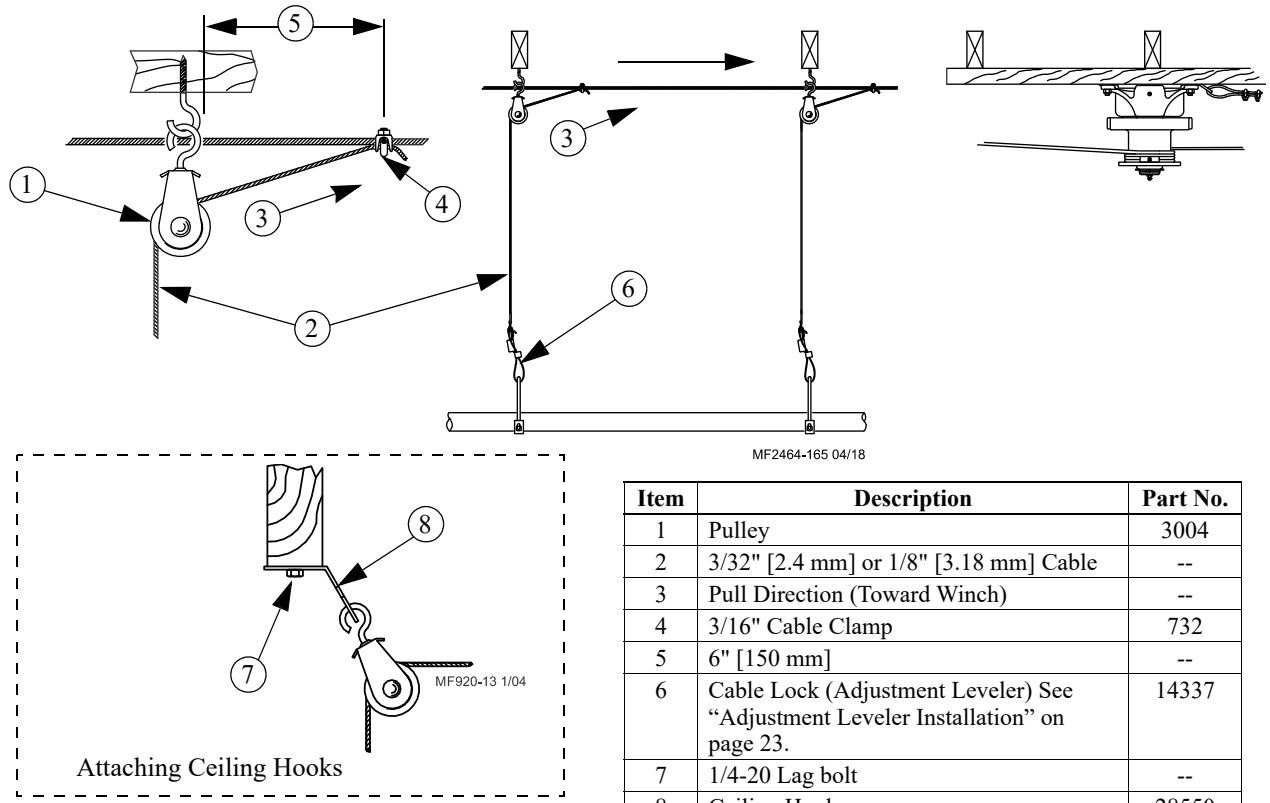

Figure 14. Standard Drop arrangement

Throwback Cable Arrangement

Cable included for Throwback pulleys beneath or near Winch (See Figure 15.)

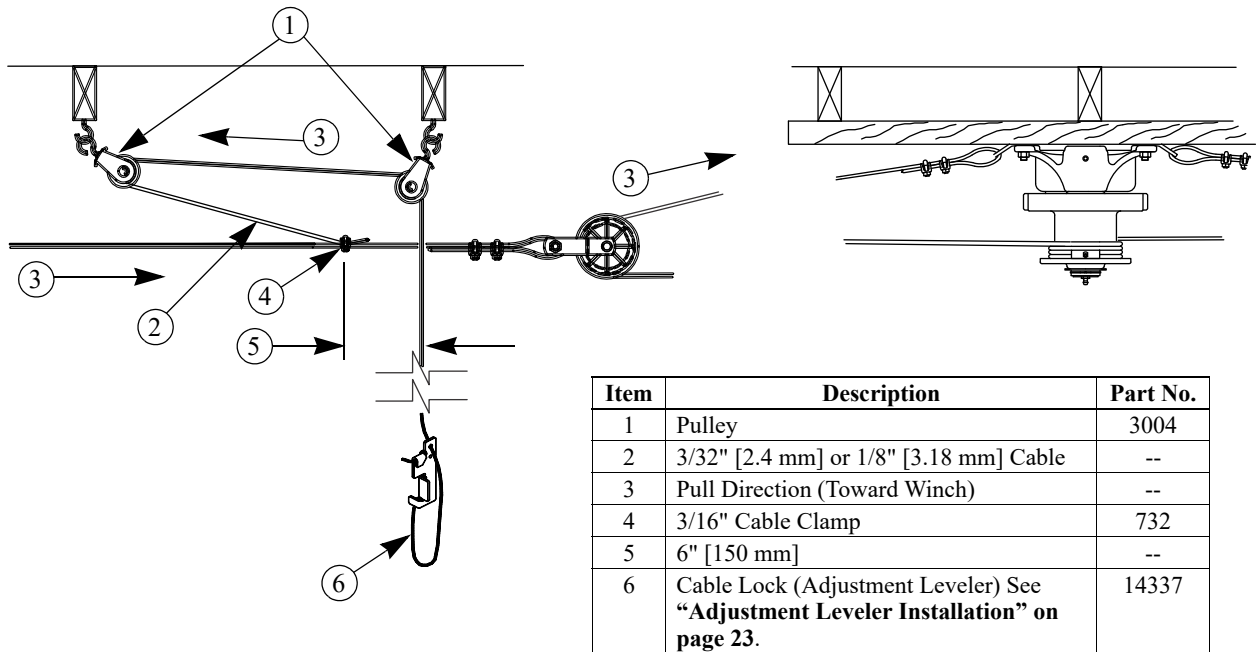

Figure 15. Drop Installation Throwback arrangement

Hopper Suspension

See Chore-Time Manual MF1819 for Hopper Assembly and installation procedure.

Assembling Feeder

1. Line up and slide the Konavi Breeder Restrictor (**Item 1**) into the Konavi Breeder Cone (**Item 2**) as shown.
2. Slide the Cone Skirt (**Item 3**) over the Feed Cone.
3. Line up the Molded Cutouts in the Chick Excluder (**Item 4**) with the raised features of the Breeder Cone and slide them together as **shown**.
4. Line up the Knobs on the Feeder Pan (**Item 5**) with the center of the Excluder (**Item 4**) Hinges and snap in place as **shown**.
5. Line up and slide the Cone Skirt (**Item 3**) over the Feed Cone (**Item 2**).
6. Line up the grooves in the Excluder with the grooves in the Feed Cone and slide them together.

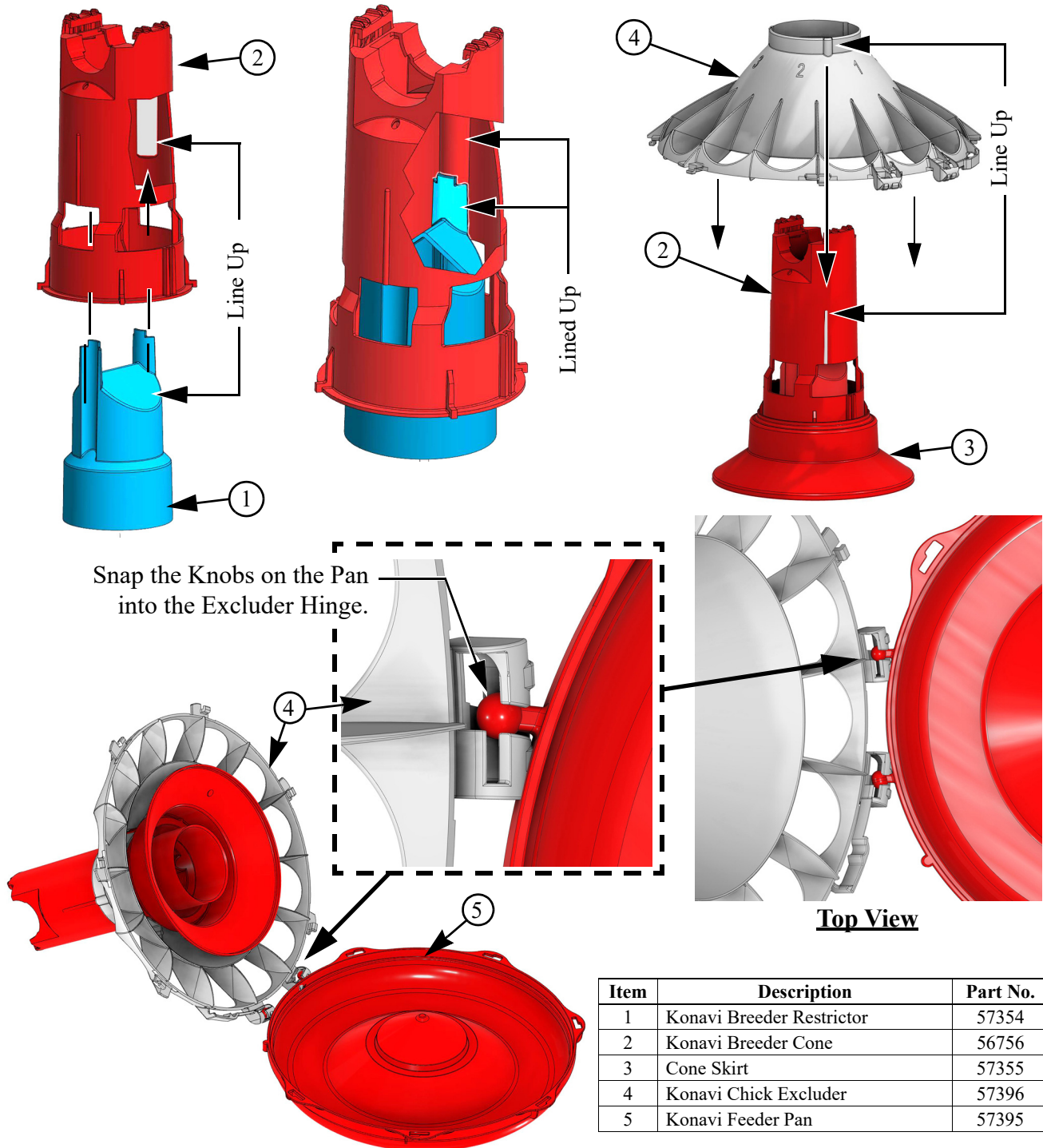
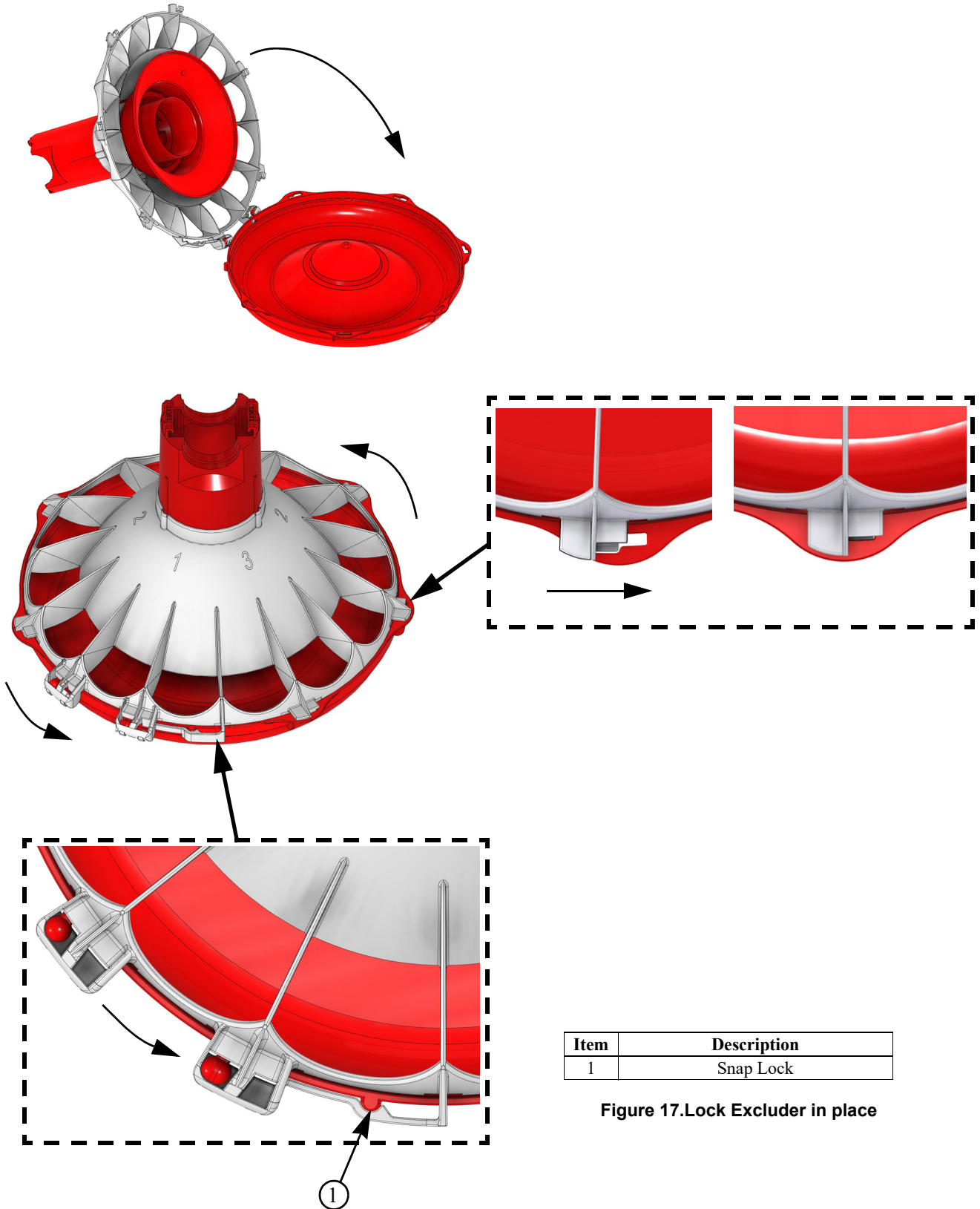

Figure 16. Feeder Assembly

- 7. Rotate the Excluder and insert the Tabs on the Excluder into the Slots in the Pan.
- 8. With all Excluder Tabs fully inserted into the slots in the Feeder Pan, rotate the Excluder Counter-Clockwise until the Excluder Snap Lock (**Item 1**) is locked in place.



Item	Description
1	Snap Lock

Figure 17.Lock Excluder in place

Feeder Line Assembly and Suspension

Installing Feeders on the Feeder Tube

Installing Cone Cap

1. Line up the Feeder with the hole in the Feeder Tube (**Item 1**)
2. **Konavi-** Set a Konavi Cone Cap (**Item 2**) on the Feeder Tube, and Slide it past the Locking Tabs so it locks into place **as shown**.

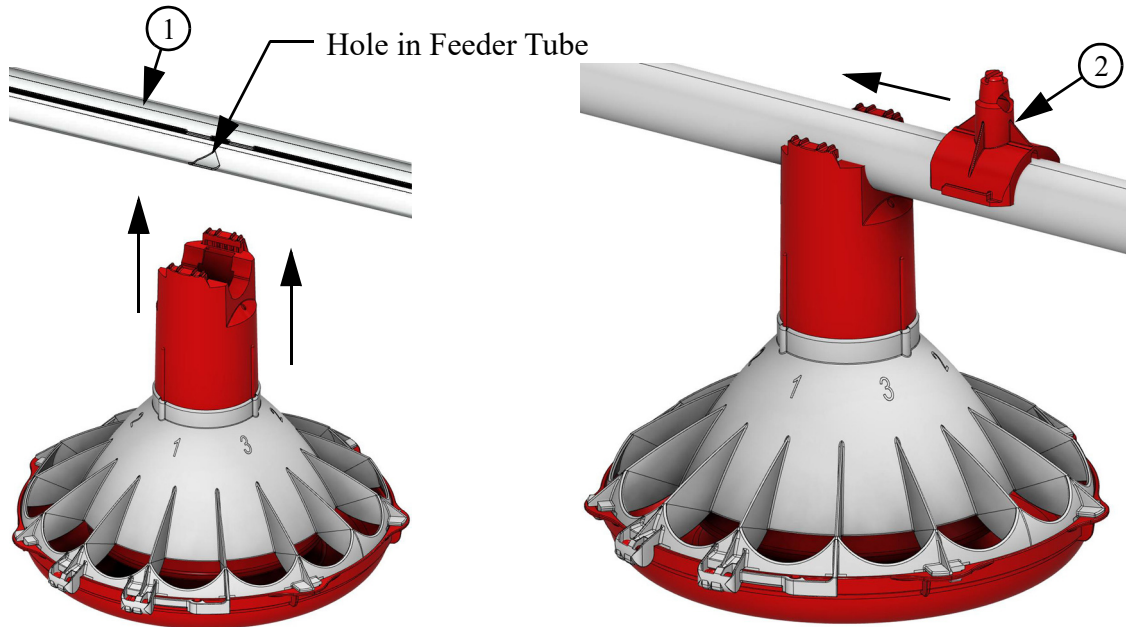

Item	Description	Part No.
1	Feeder Tube	--
2	Konavi Cone Cap	56753

Figure 18. Feeder Installation

Assembling and Suspending the Feeder Tubes

1. The Feeder Tubes and Feeders may be laid out end to end in approximately the final location of the line. **The belled end of each Tube should be toward the Hopper end. (See Figure 19.)**
 2. Connect the individual feeder tubes together by inserting the straight end of one tube as far as possible into the belled end of the next tube. **The last Feeder Tube before the End Control Pan (Item 2) or Mid Line Control pan (Item 1) needs to be a Control Tube.**
 3. Use a marker to number the Feeder Tubes, beginning at the Hopper.
 4. The first Feeder Tube at the hopper end of the feeder line would be 1, the second Feeder Tube would be 2, etc. Mark each Feeder Tube between the Hopper and the Control Unit.
 5. Install a Tube Clamp Assembly (Item 5) or Clamp and Anti-Roost Bracket (Item 8) at each joint as shown, but **DO NOT** tighten yet.
- Important: Do not tighten** down Tube Clamps at this time. They will be tightened down when the Tubes are indexed!
6. Systems require an Anti-Roost Bracket at every **fifth** joint.
 7. Continue down the feeder line until each tube joint has a standard Tube Clamp or Clamp/Anti-Roost Bracket.

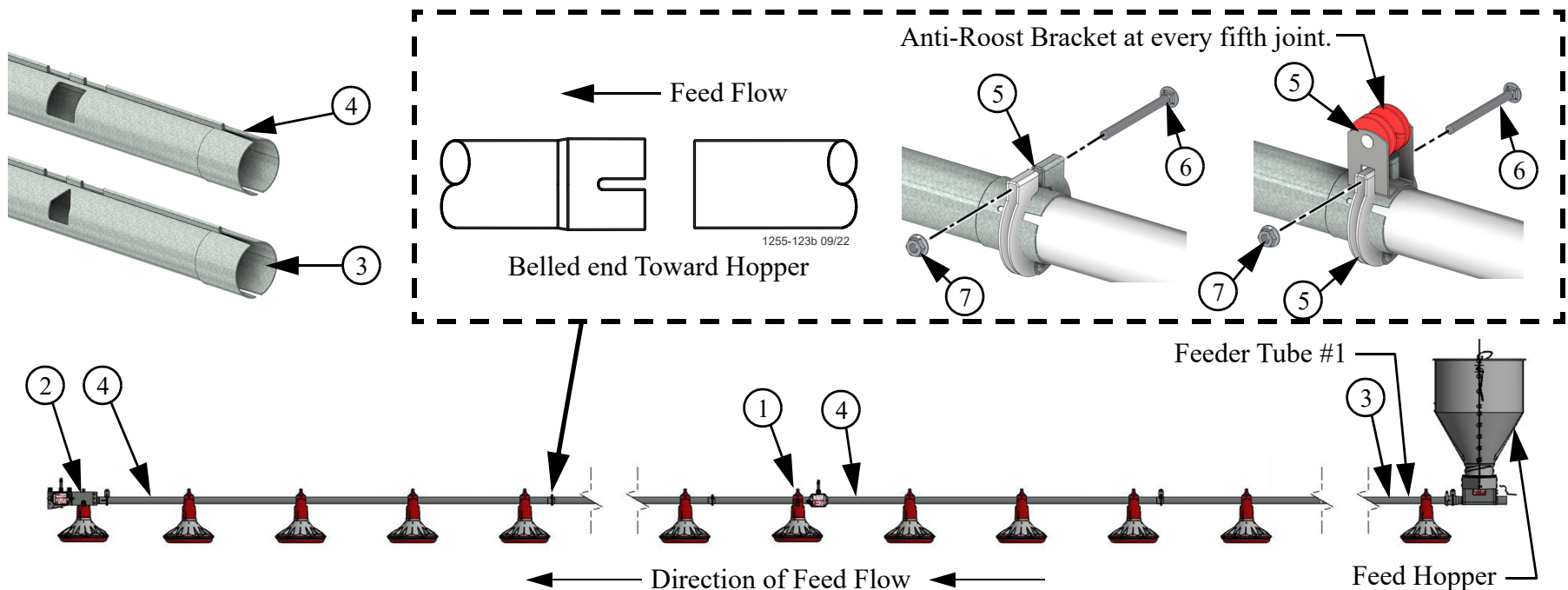

Item	Description	Part No.
1	KONAVI® Proximity Sensor Mid Line Control	57453
2	KONAVI® Proximity Sensor End Control	57425
3	10', 4 Hole Feeder Tube	6854-4
4	10', 4 Hole Control Feeder Tube	43006-4

Item	Description	Part No.
5*	Tube Clamp Assembly	24062
6*	1/4-20 x 2.5 Carriage Bolt	7550-3
7*	1/4-20 Flange Nut	46460
8	Anti-Roost Bracket	24060

*Included in 24063-X Tube Clamp Kit

Figure 19. Hanger Installation

Installing Adjustable Hangers

- Refer to the appropriate Indexing Chart on **page 25** of this manual to program the Feeder Tubes.
 - Find the heading for the number of tubes in your feeder line in the horizontal line at the top of the Indexing Chart. The correct hanger adjustments for each Feeder Tube are shown in the column under the heading.
1. Install the Hangers (**Item 1**) on the Feeder Tubes at the 8' [2.4 m] spacings determined by the suspension drop lines. Program each Feeder Tube in the feeder line according to the Indexing Chart. Some Feeder Tubes may have (2) Hangers. Both Hangers should be indexed to the same setting.
 2. Installing the Adjustment Levelers is shown on **page 23**.

Setting Example: If the appropriate setting for the #1 Feeder Tube is B5, the “S” Hook should be installed in the #5 hole in the Hanger. The Feeder Tube Seam should be in the “B” position. (See Figure 20.)

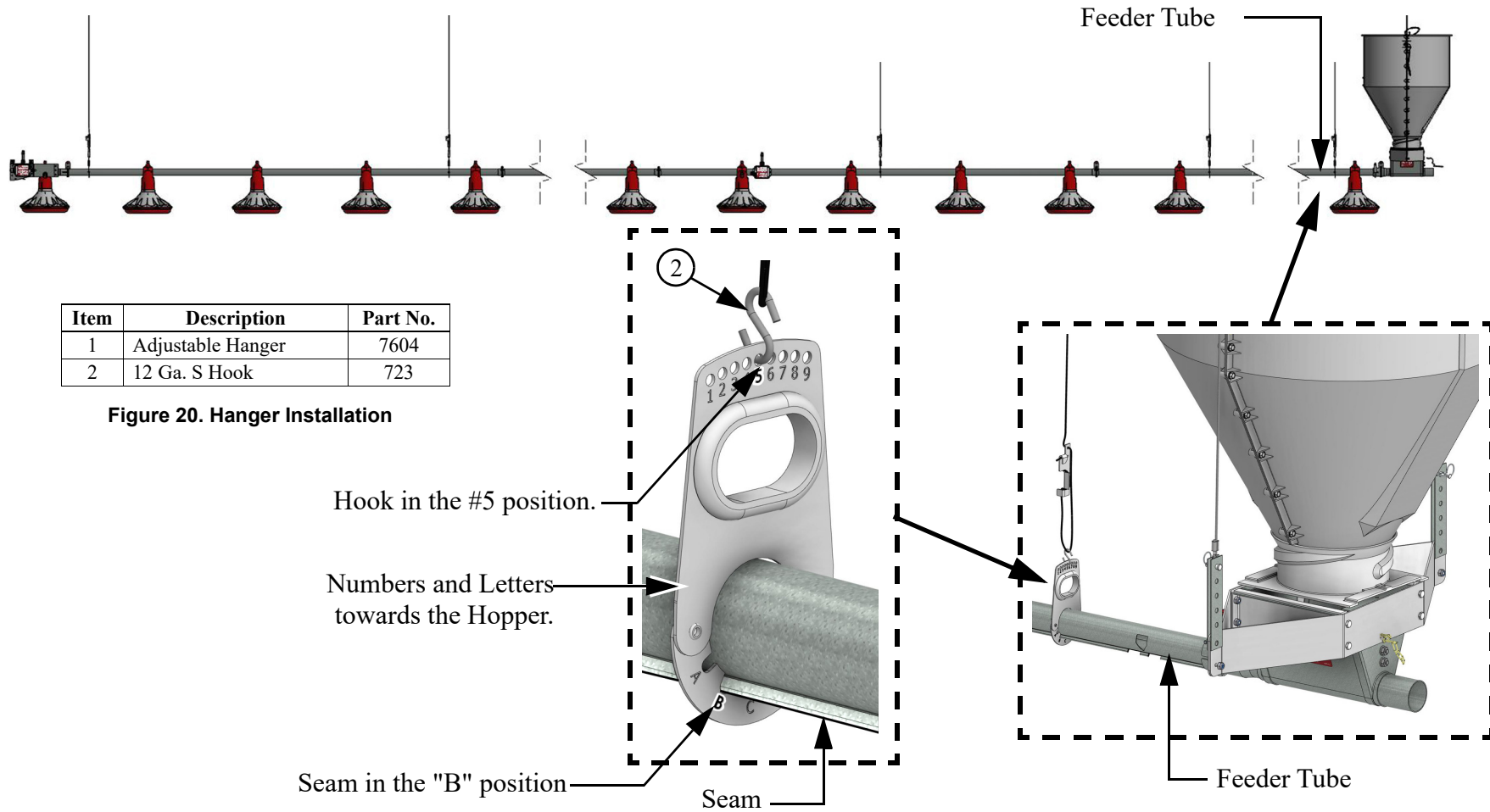

Suspending the Feeder Line

Adjustment Leveler Installation

1. Install Adjustment Levelers (**Item 1**) at each Adjustable Hanger. Install the S Hooks (**Item 2**) in the proper hole of the Hanger as **shown** on the previous page.
2. See **Figure 21**. for proper cable routing around the Adjustment Leveler. The maximum distance from the Leveler to the S Hook is 6" [152mm].
3. Lift the Feeder line to a comfortable working height and check that the Seams in the Feeder Tube are indexed properly. There should be no big gaps from one Tube to the next (**See Figure**). It should be a smooth transition from one end of the system to the other.
4. Tighten down all of the Tube connectors at this time. **Do not** crush the tubes by over-tightening the clamps.

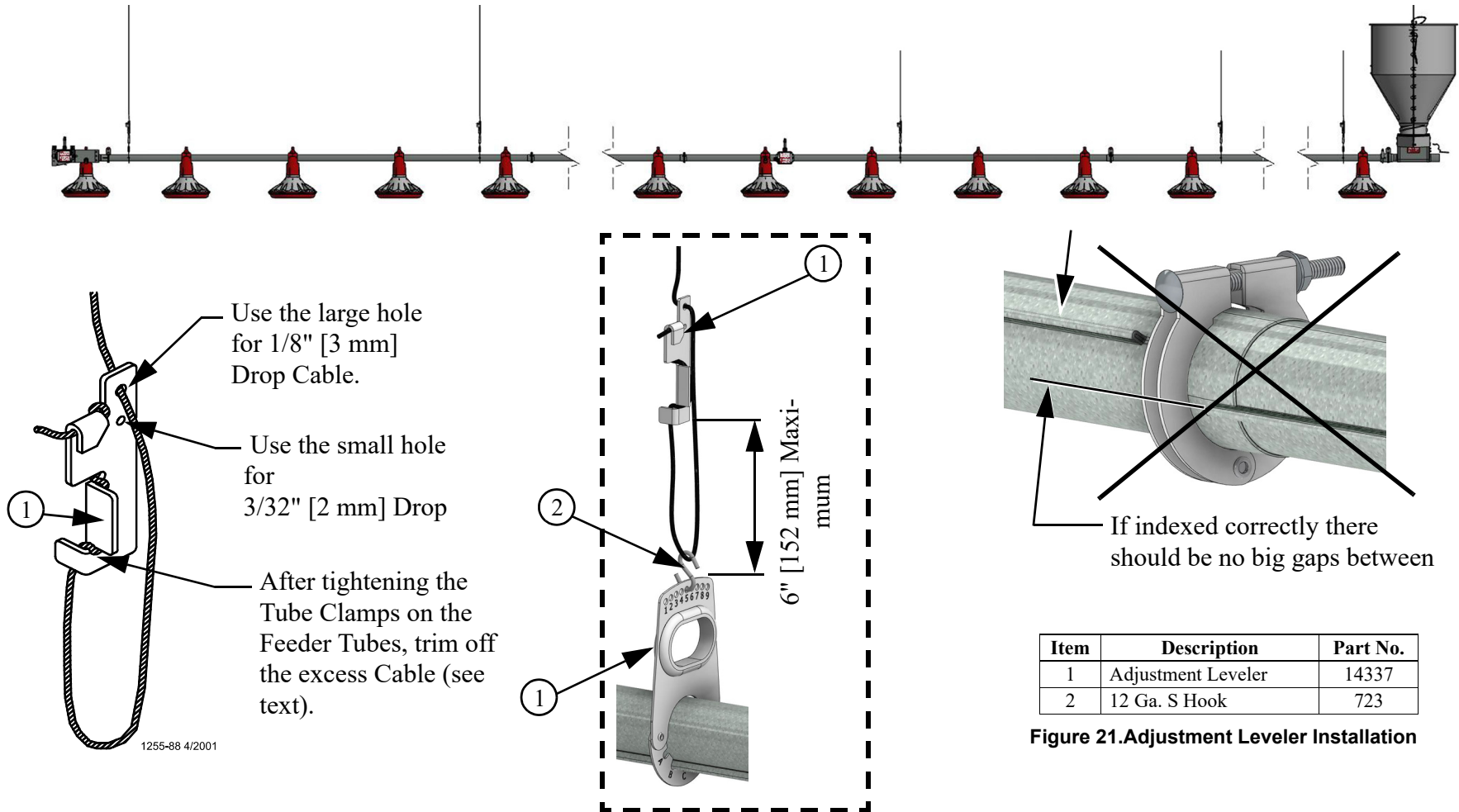
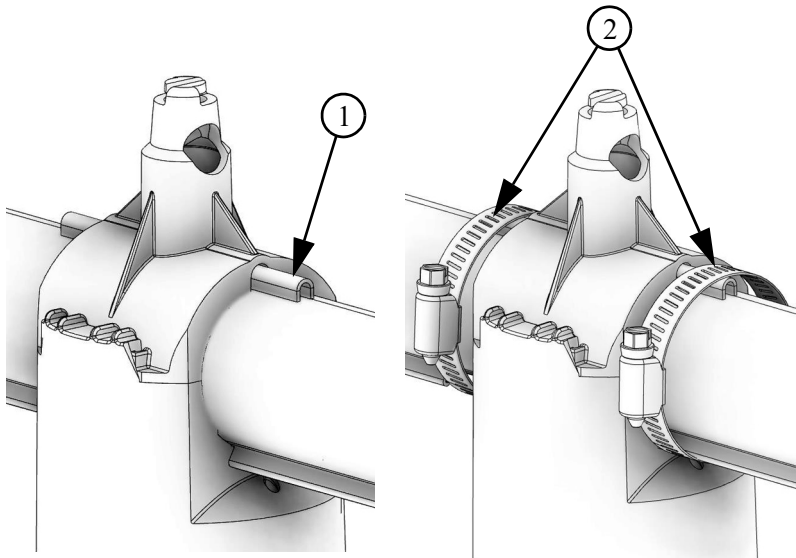

Figure 21. Adjustment Leveler Installation

Anti-Swing Clamp

1. Insert a Locking Pin (**Item 1**) into the slot in the Cone Cap as shown.
2. Install two Adjustable Hose Clamps (**Item 2**) to hold the Locking Pin in place and eliminate rotation of the Feeder on the Feeder Tube.



Item	Description	Part No.
1*	Locking Pin	14484
2*	Adjustable Hose Clamp	3527
*Included in 14485 Anti-Swing Clamp Kit.		

Figure 22. Anti-swing Clamp Kit

Indexing Chart for Pullet Feeders

Systems using 10' (3 m) Feeder Tube

		Number of Tubes															
		30	29	28	27	26	25	24	23	22	21	20	19	18	17	16	
Tube Number	1	B5	B5	B6	B6	B6	B6	B6	B7	B7	B7	B8	B8	B8	B9	B9	1
	2	B6	B6	B7	B7	B7	B7	B7	B8	B8	B8	B9	B9	B9	C1	C1	2
	3	B7	B7	B8	B8	B8	B8	B8	B9	B9	B9	C1	C1	C1	C1	C2	3
	4	B8	B8	B9	B9	B9	B9	B9	C1	C1	C1	C1	C1	C2	C2	C3	4
	5	B9	B9	C1	C1	C1	C1	C1	C1	C1	C2	C2	C2	C2	C3	C4	5
	6	C1	C1	C1	C1	C1	C1	C2	C2	C2	C2	C2	C2	C3	C4	C5	6
	7	C1	C2	C2	C2	C2	C2	C2	C2	C2	C3	C3	C3	C4	C5	C6	7
	8	C2	C2	C2	C2	C2	C2	C3	C3	C3	C4	C4	C4	C5	C6	C7	8
	9	C2	C3	C3	C3	C3	C3	C4	C4	C4	C5	C5	C5	C6	C7	C8	9
	10	C3	C3	C3	C4	C4	C4	C4	C4	C5	C6	C6	C6	C7	C8	D2	10
	11	C3	C4	C4	C4	C4	C5	C5	C5	C6	C7	C7	C7	C8	D2	D4	11
	12	C4	C4	C4	C5	C5	C5	C6	C6	C7	C7	C8	C8	D2	D4	D6	12
	13	C4	C5	C5	C5	C5	C6	C7	C7	C7	C8	C8	D2	D4	D6	D7	13
	14	C5	C5	C5	C6	C6	C7	C7	C7	C8	C8	D2	D4	D6	D7	D8	14
	15	C5	C6	C6	C7	C7	C7	C8	C8	C8	D2	D4	D6	D7	D8	E3	15
	16	C6	C6	C7	C7	C7	C8	C8	C8	D2	D4	D6	D7	D8	E3	E5	16
	17	C6	C7	C7	C8	C8	C8	D1	D2	D4	D6	D7	D8	E3	E5		17
	18	C7	C7	C8	C8	C8	D1	D2	D4	D6	D7	D8	E3	E5			18
	19	C7	C8	C8	D1	D1	D2	D4	D6	D7	D8	E3	E5				19
	20	C8	C8	D1	D2	D2	D4	D6	D7	D8	E3	E5					20
	21	C8	D1	D2	D3	D4	D6	D7	D8	E3	E5						21
	22	D1	D2	D3	D4	D6	D7	D8	E3	E5							22
	23	D2	D3	D4	D6	D8	D8	E3	E5								23
	24	D3	D4	D6	D8	D9	E3	E5									24
	25	D4	D6	D8	D9	E3	E5										25
	26	D6	D8	D9	E3	E5											26
	27	D8	D9	E3	E5												27
	28	D9	E3	E5													28
	29	E3	E5														29
	30	E5															30

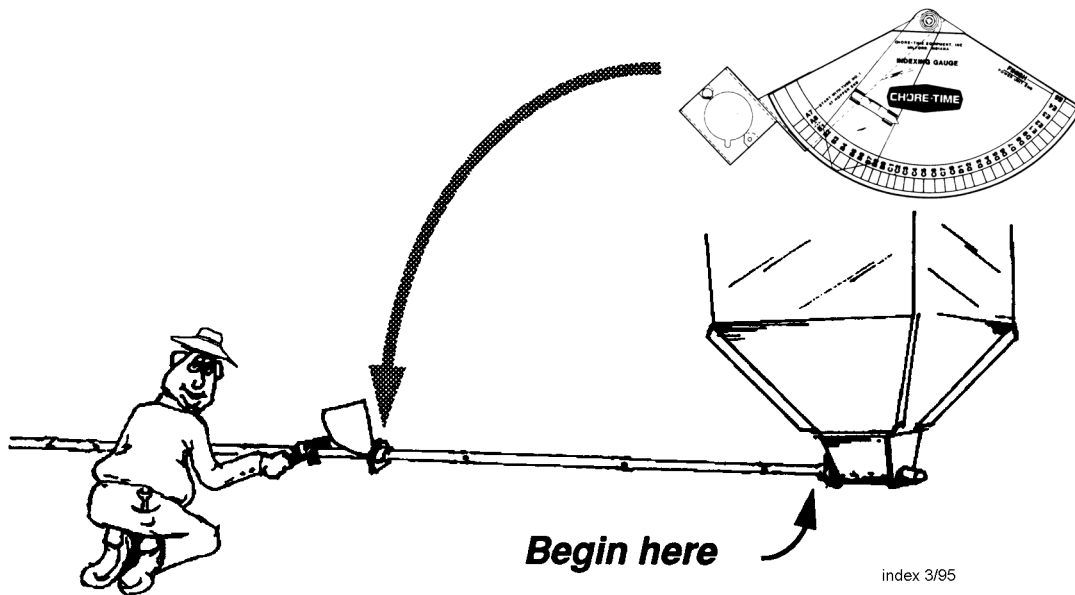

index 3/95

Installing the End Control and Boot Assembly

The End Control Unit must be at least 10 feet [3 m] from the end of the building to allow birds access around the end of the feeder line.

1. Assemble the End Control Unit to the Feeder Line Control Tube using a clamp/anti-roost bracket. See **Figure 23. DO NOT INSTALL THE POWER UNIT AT THIS TIME.**

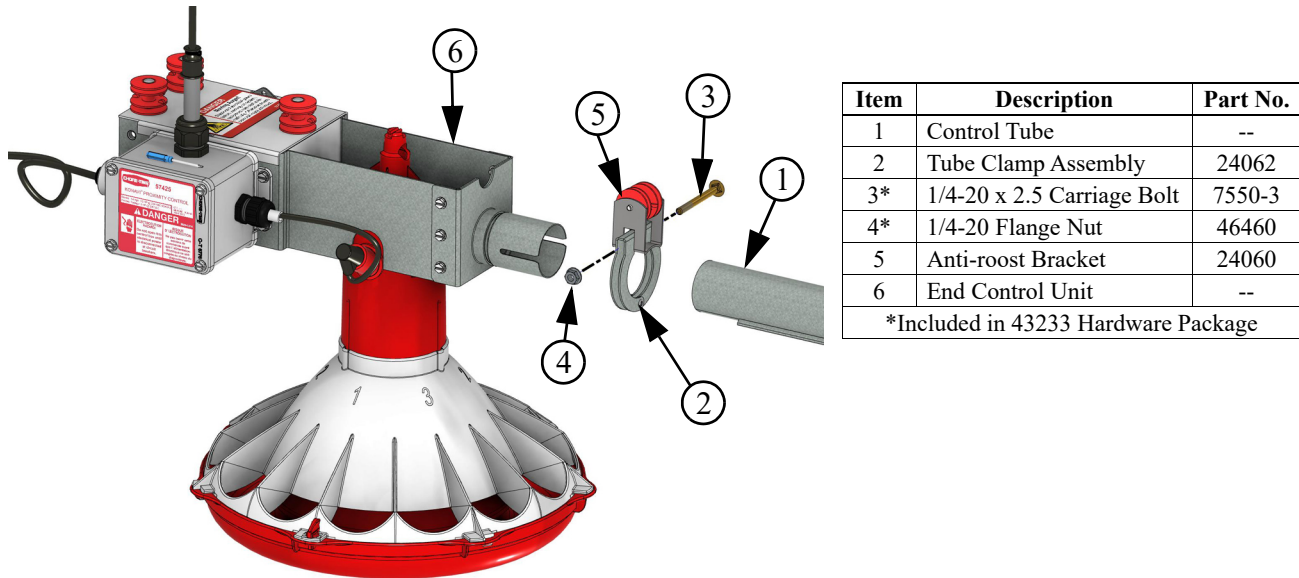

Figure 23. Connecting End Control Unit to the Feed Line Tube

2. Install the Feeder Boot (Item 1) by sliding the straight end of the Feeder Boot into the belled end of the Feeder Tube. Install a Clamp Assembly (Item 2) and Anti-roost Bracket (Item 3) on the bell and tighten.

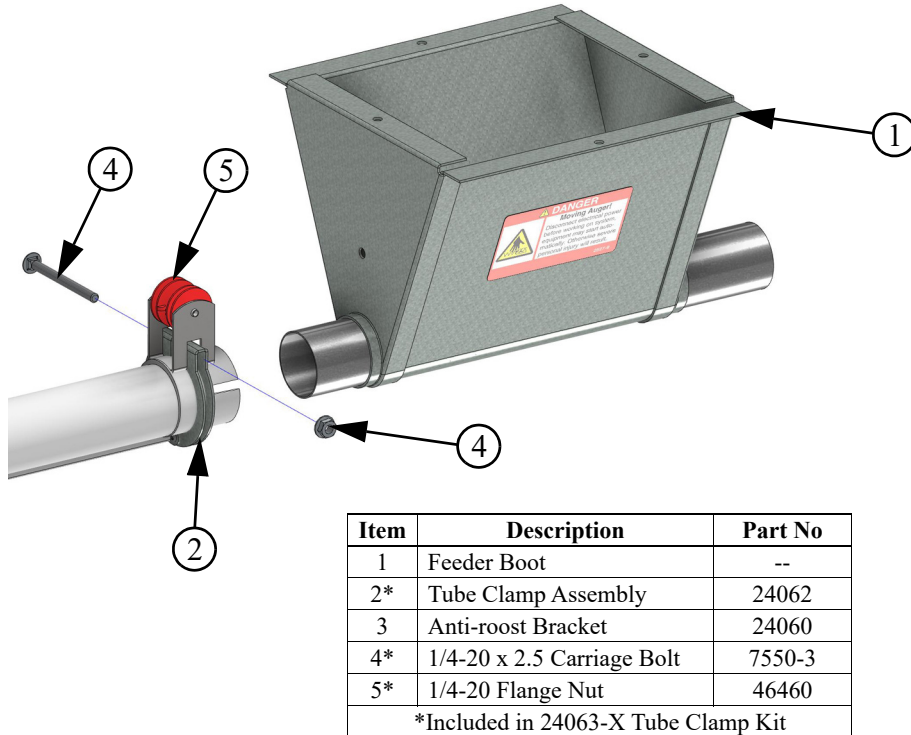
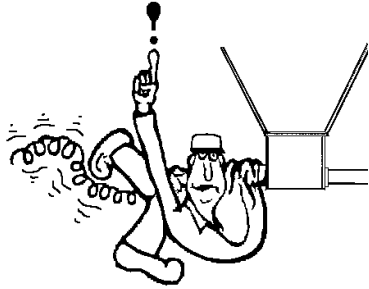

Figure 24. Installing the Feeder Boot

Auger/End Control Installation



Use extreme caution when working with the auger. The auger is under tension and may spring causing personal injury. Wear protective clothing, gloves, and safety glasses when working with the auger.



BE CAREFUL WHEN WORKING WITH THE AUGER!

To avoid kinking the auger, be careful not to drop the rolled auger when handling. Inspect the auger carefully as it is installed. Small kinks may be straightened. Large kinks must be removed and the auger brazed back together.

1. Cut the leading 18" [450 mm] and last 18" [450 mm] off each roll of auger. Also, cut out any other distorted auger sections and reconnect the auger as specified in the Auger Brazing section of this manual.

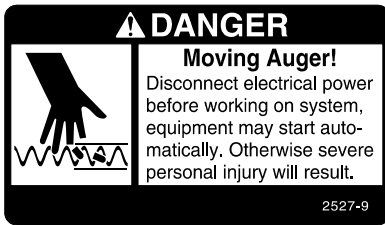

Use extreme caution when pushing the auger into the Feeder Tubes. Keep your hand away from the end of the Feeder Tube to avoid injury.

2. With the auger coiled about 6 feet [1.8 m] from the end of the boot, uncoil the auger from the outside and feed the auger through the boot into the tubes.
3. Push the auger into the tube in short strokes.
4. Uncoil and handle the auger carefully to avoid damaging or kinking the auger.
5. If more than one coil is required for each feeder line, the Auger ends will have to be brazed together. Refer to the Brazing the Auger section in this manual.
6. Install the Anchor Plate to the Power Unit/Gearhead, as shown in **Figure 25**.

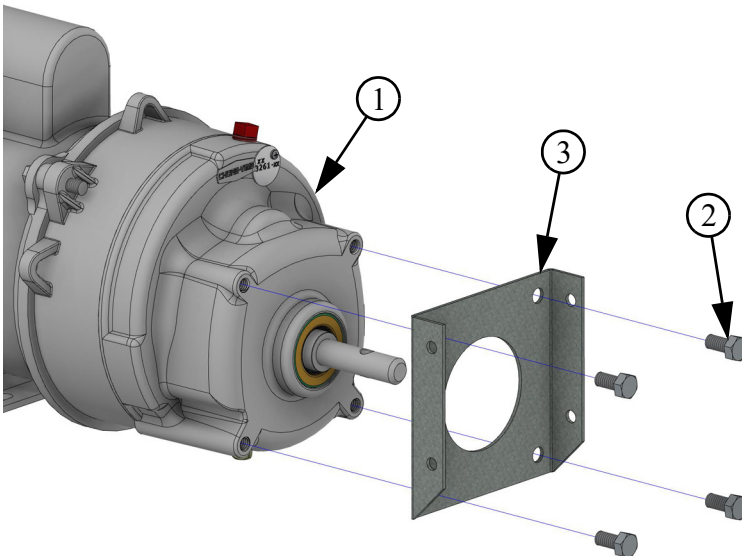

Item	Description	Part No.
1	Power Unit	--
2	5/16-18 x .63 Bolt	1412-1
3	Anchor Plate	4188

Figure 25. Assemble the Anchor Plate to the Power Unit/Gearhead

7. Slide the Drive Tube and flat washer over the output shaft on the Power Unit, as shown in **Figure 26**.
8. Continue installing Auger until the Auger reaches the Control Unit end of the feeder line.
9. Turn the Drive Tube Weldment into the Auger, then attach to the output shaft of the Power Unit, as shown in **Figure 26**. Use the Driver Block to secure the auger to the Output Shaft.

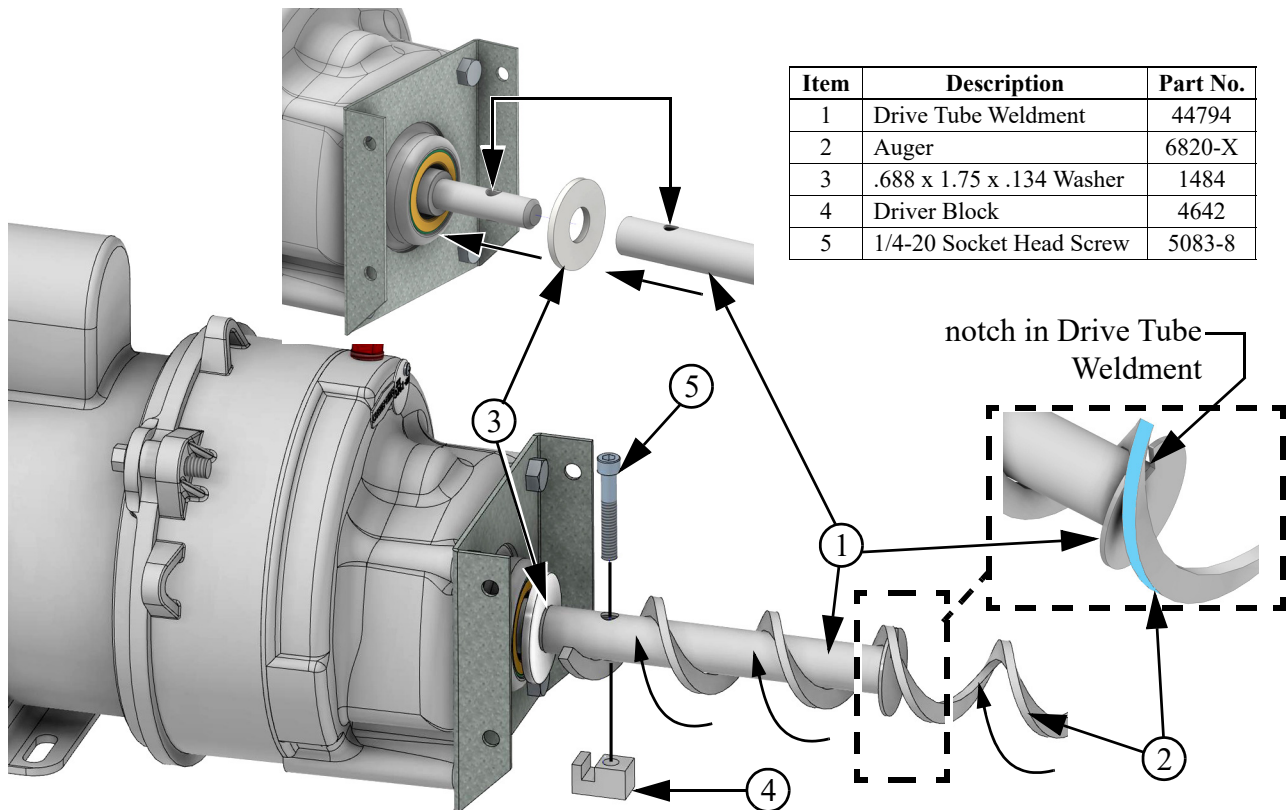

Figure 26. Auger Driver Components

10. Attach the Anchor Plate and Gearhead Assembly to the Control Unit Body using the included hardware shown in **Figure 27**.

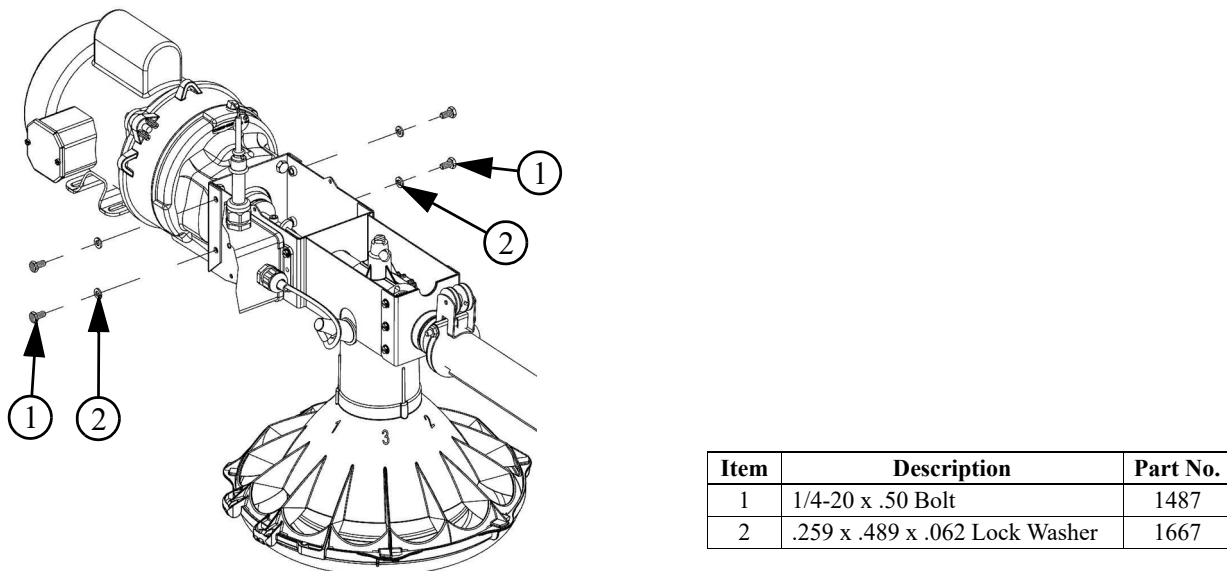
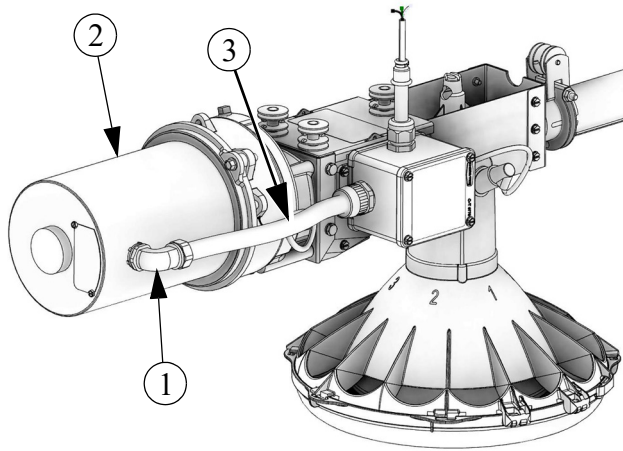

Figure 27. Attaching the Anchor Plate and Gearhead Assembly to the Control Unit Body

11. Install the Metal Water Tight Connector (**Item 1**) in the Power Unit (**Item 2**). Cut the Flex Conduit (**Item 3**) to length. Slide the wires from the end control through the Flex Conduit (**Item 3**). Install the Flex Conduit (**Item 3**) in the connectors.

12. See “Power Unit Wiring” on page 38 for wiring for various Power Units.



Motor without Conduit Box

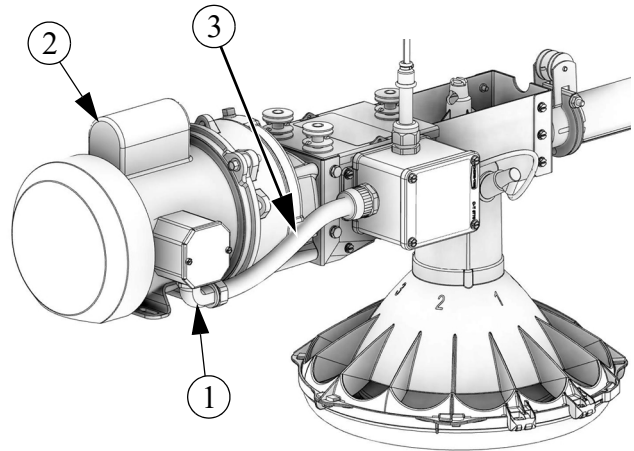

Motor with Conduit Box

Item	Description	Part No.
1	Water Tight Connector	23810
2	Power Unit	--
3	Flex Conduit	
*Items 1 & 3 in		

Figure 28. Installing Water Tight, Cutting and Installing Conduit

13. Attach all covers and wire according to the wiring section of this manual.



Auger Stretch

Use caution when working with the Auger--springing auger may cause personal injury.

Proper Auger Stretch is 7" [180 mm] per 100' [30 m]. Example: A 300' [90 m] feeder line requires 21" [500 mm] of stretch. Measure the amount of stretch from the rear edge of the boot and cut the Auger at that point. (See Figure 29.)

1. Pull on the loose end of the Auger at the boot once or twice until it begins to stretch, then release it slowly. This will bring the auger to its natural length.
2. Measure and mark the Auger at the point where it is to be cut (See **Auger Stretch** above).
3. Pull the Auger until the Mark is out far enough to allow for the Anchor and Bearing Assembly (**Item 1**) to be installed and use Vice Grips to hold the Auger in place as shown.
4. Cut the Auger at the Mark.
5. Insert the Anchor and Bearing Assembly into the Auger and feed it between the two Auger Spirol Pins (**Item 2**) until the Auger touches the Washer on the Anchor and Bearing Assembly. Tighten the Auger Clamp Screws (**Item 3**) to 10-12 ft.-lbs. **Note:** *Over tightening the Set Screw may cause damage to the Auger Clamp.*

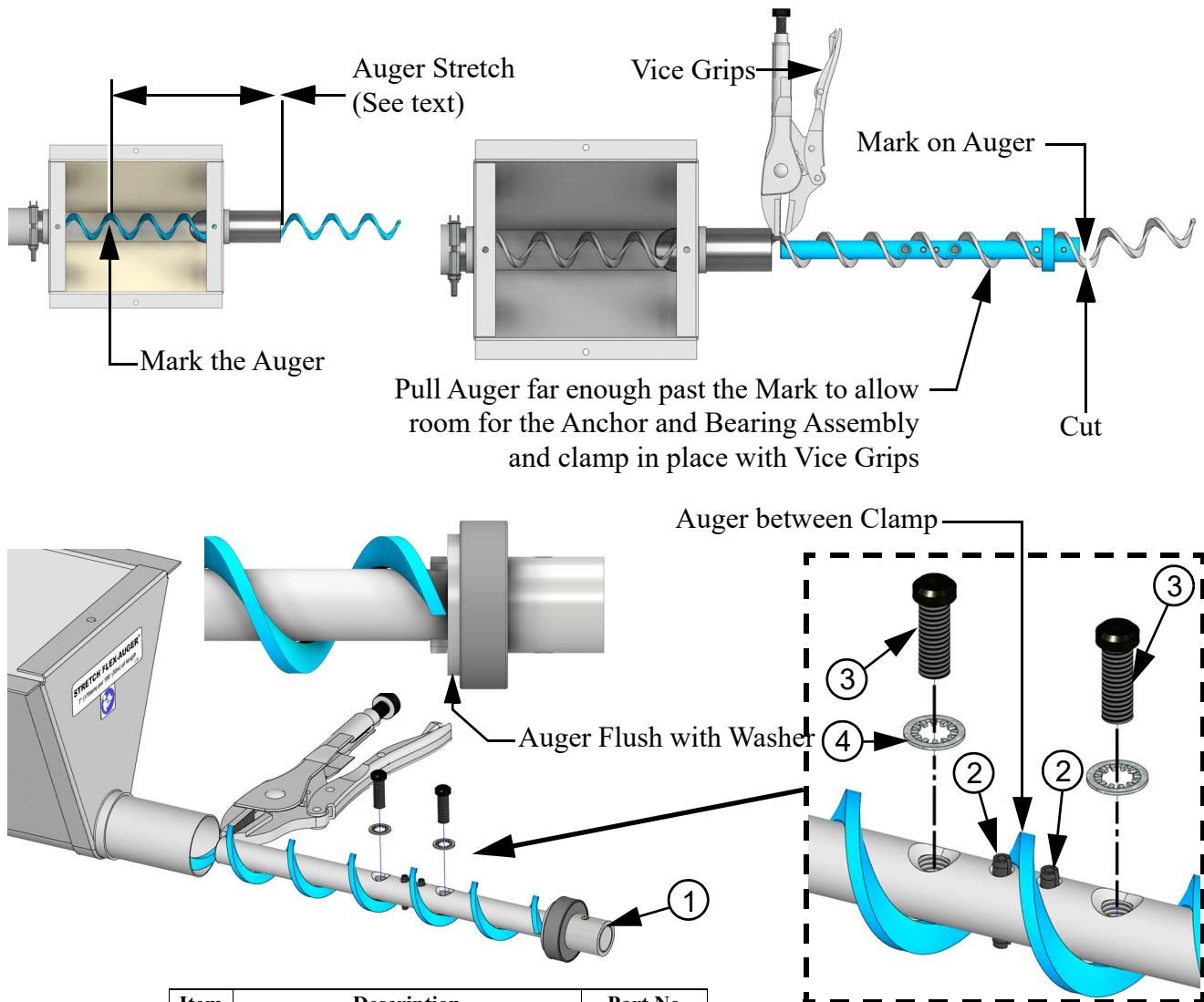

Item	Description	Part No
1	Anchor and Bearing Assembly	39372
2	Spirol Pin	2960-1
3*	5/16-18 x .875 Auger Clamp Screw	47867
4*	5/16 Lock Washer	48609

*Included in Anchor and Bearing Assembly

Figure 29. Auger Installation (Stretch)



Use caution when working with the Auger--springing auger may cause personal injury

6. Carefully remove the Vice Grips to allow the Auger to snap into place.
7. Install the Stub Tube (Item 1), Cap (Item 2), and Tube Clamp (Item 3) as shown.

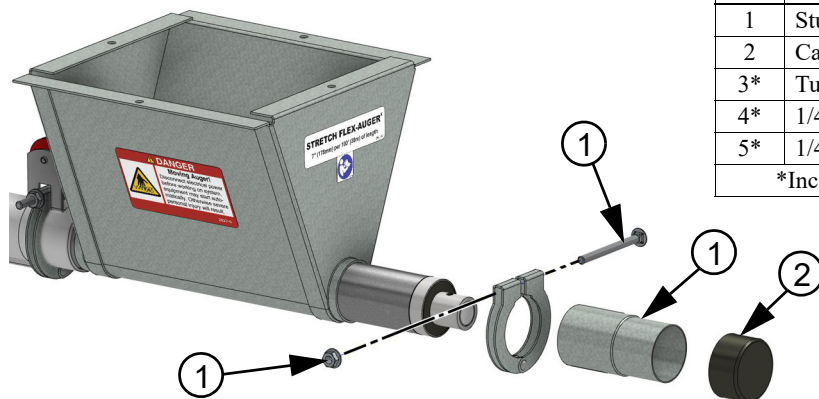

Item	Description	Part No
1	Stub Tube	4556
2	Cap	29373
3*	Tube Clamp Assembly	24062
4*	1/4-20 x 2.5 Carriage Bolt	7550-3
5*	1/4-20 Flange Nut	46460
*Included in 24063-X Tube Clamp Kit		

Figure 30. Stub Tube, Cap and Clamp

8. Install the Bearing Retainer and fasten with a tube clamp. Keep the Bearing Retainer flush with the end of the anchor for safety.
9. Place the cannonball in the boot.

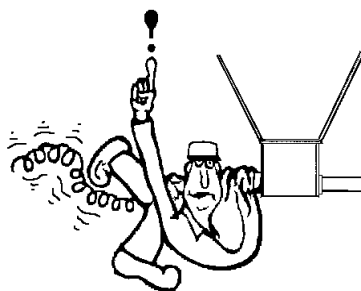

BE CAREFUL WHEN WORKING WITH THE AUGER!

Auger Brazing

The auger should be brazed if it is necessary to splice or lengthen it. A bronze, flux coated rod is recommended. The ends of the auger should butt against each other, **DO NOT THREAD INSIDE EACH OTHER**. The joint should be well filled with no sharp edges or rough corners to wear against the tube. To align the auger for brazing, lay it in angle or channel iron and clamp it firmly in place. Use low heat. Allow the joint to air cool; rapid cooling will cause the auger to become brittle.

Lap the Auger ends approximately 1" [25 mm]

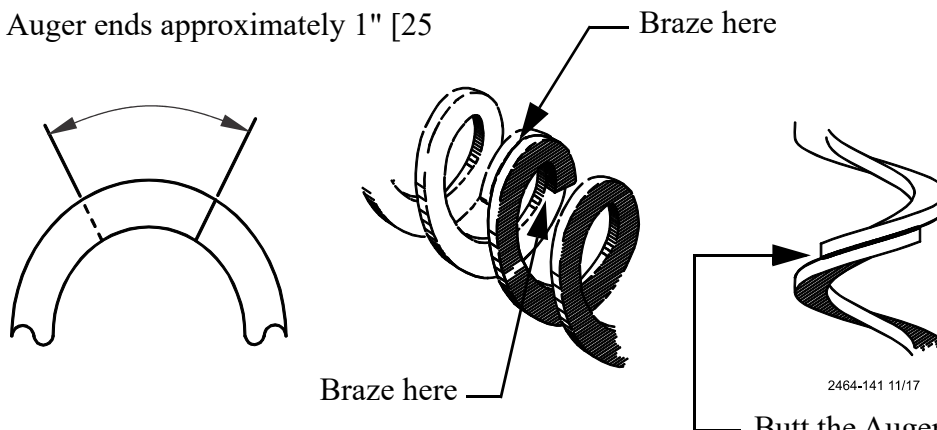

Figure 31. Auger Brazing

Butt the Auger ends together. **DO NOT** thread the Auger together

Mid-Line Control

Location/Planning

The Mid-Line Control makes it possible to operate the feeding system when birds are confined away from the End Control Unit. Chore-Time recommends placing the Mid-Line Control Feeder at least 2 pans away from the curtain or partition. (See Figure 32.)

New Feeder Lines

Leave one Feeder Pan assembly off the Feeder Control Tube at the point where the Mid-Line Control needs to be placed. The feeder line can be assembled and suspended before attaching the Mid-Line Control; or the Mid-Line Control may be attached to the Feeder Tube when the other pans are installed.

Existing Feeder Lines (Retro-Fit)

1. Cut the Support Cone and remove the Feeder Pan at the location where the Mid-Line Control will be installed.

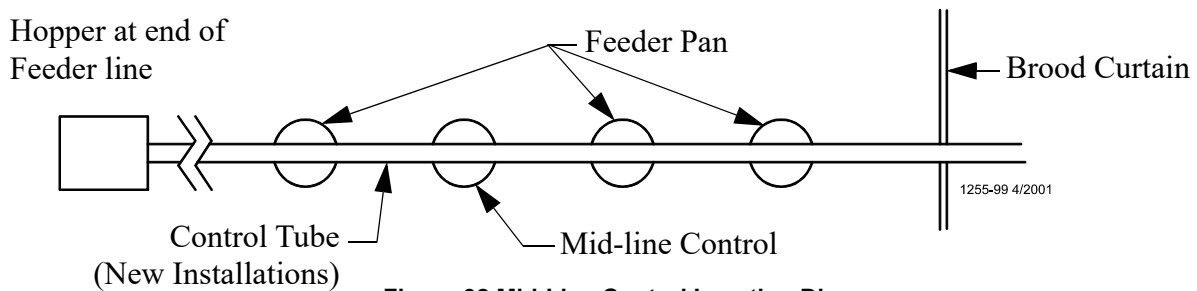

Figure 32. Mid-Line Control Location Diagram

Installation

Feeder Tube Outlet Holes (Retro-Fit application)

New Feeder Lines: Skip to next section.

Existing Feeder Lines (Retrofit):

1. Use a Uni-bit to enlarge the outlet hole to approximately 1" [2.5 cm] diameter for the Mid-Line Control.
2. Use a Uni-bit to enlarge (2) outlet holes in front (to the hopper end) of the Mid-Line Control.

Note: Use a Uni-Bit to drill the holes. Be sure there are no burrs inside the tube to catch the Auger.

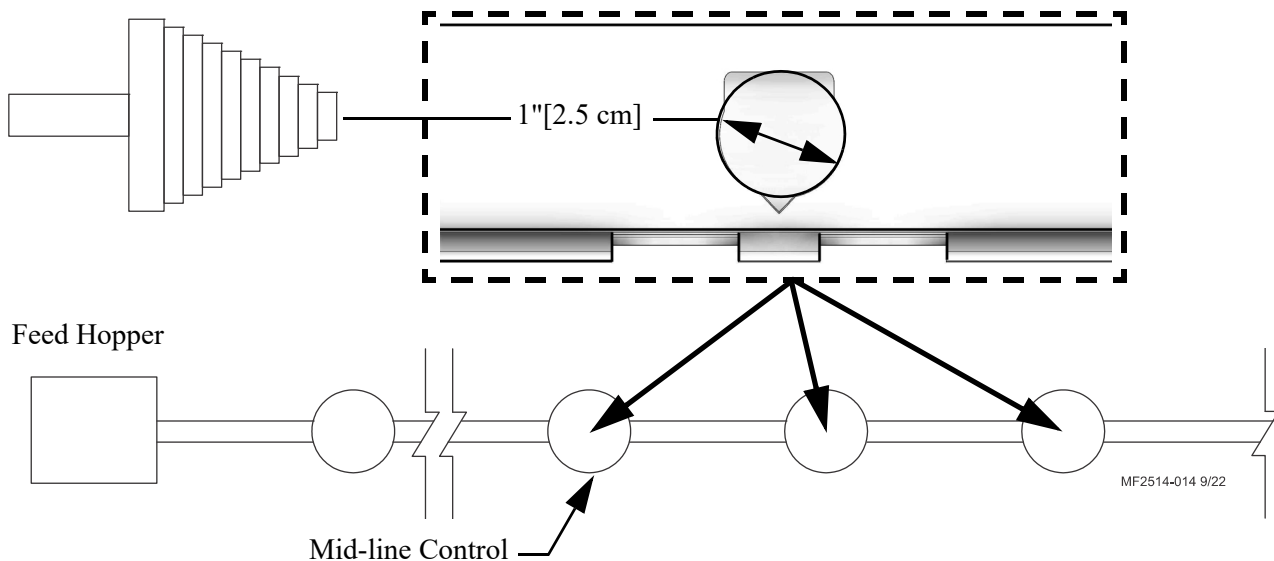

Figure 33. Drilling Holes at Midline (Retro-fit)

Attaching the Mid-Line Control

Mid-Line Control with Proximity Sensor Control

The Mid-Line Control is installed on a Control Tube. The Control Tube is a special Feed Tube that has enlarged holes required for the Mid-Line Control.

1. Attach the Mid-Line Control (**Item 1**) to the Control Tube (**Item 2**) as shown in **Figure 34**.
2. Attach the Switch Box Assembly to the Control Tube with Tube Clamps (**Item 3**).
3. Install a toggle switch, out of reach of the birds, to disconnect power to the Mid-Line Control. This allows the Mid-Line Control to serve as standard feeder when not used as a Control Feeder.
4. Wire the Mid-Line Control as shown in the wiring diagram section of this manual. Insert a Locking Pin (**Item 5**) into the slot in the Cone Cap as shown.
5. Install two Adjustable Hose Clamps (**Item 6**) to hold the Locking Pin in place and eliminate rotation of the Feeder on the Feeder Tube.

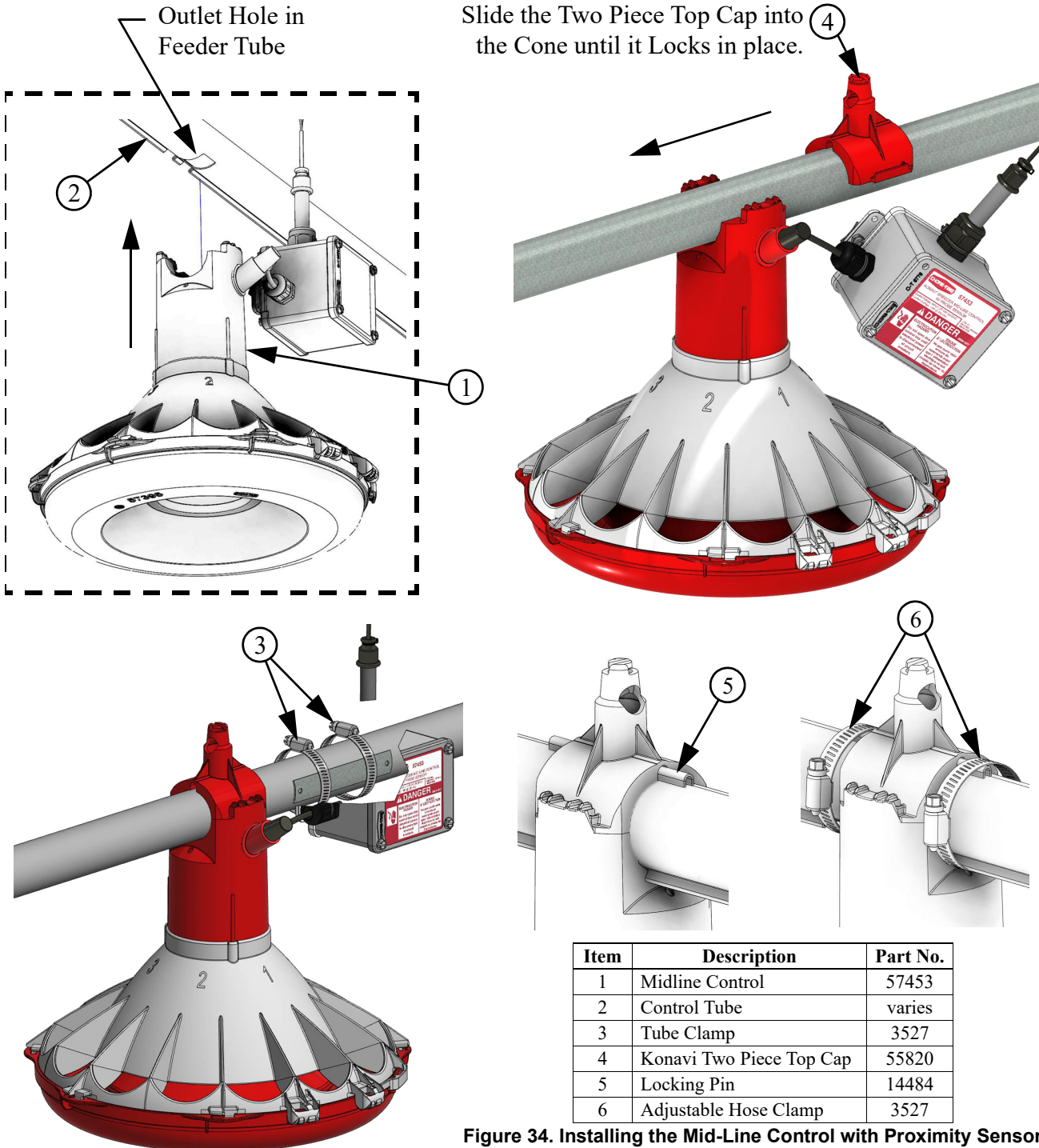

Item	Description	Part No.
1	Midline Control	57453
2	Control Tube	varies
3	Tube Clamp	3527
4	Konavi Two Piece Top Cap	55820
5	Locking Pin	14484
6	Adjustable Hose Clamp	3527

Figure 34. Installing the Mid-Line Control with Proximity Sensor

Anti-Roost Assembly

1. Unroll the bulk anti-roost cable. Note: If the cable is unrolled as shown in **Figure 35.**, taking 5 loops of the coil with one hand, then changing hands to remove 5 loops as it is unrolled, it will lie flat during installation.



Figure 35. Unrolling Cable

2. Start at the hopper end of the line and form a loop around the anti-roost bracket. For best results, make a double loop around the anti-roost insulator in the center groove of the insulator and fasten with a 1/16" cable clamp as shown in **Figure 36.**
3. Insert the cable in the insulator on the top of each Grill Support between the hopper and the next anti-roost bracket.

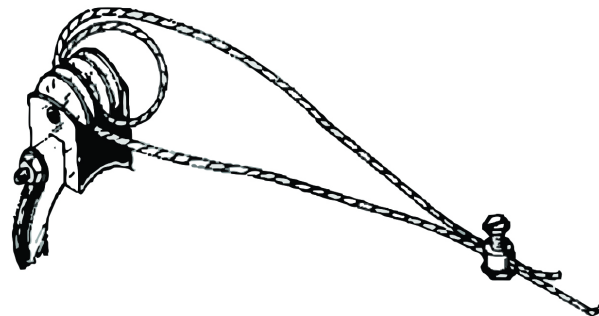

Figure 36. Anti-Roost Cable at the Hopper

4. Attach a spring in the center groove at the second anti-roost bracket and cut the cable at this point. see **figure 37.**
5. Thread the ends of the cable through the end of the spring. Pull the cable tight so that there is 3/4" to 1" [20 to 25 mm] of stretch in the spring. Clamp the cable to form a loop and cut off any excess. see figure 37.
6. Attach the cable to the insulator. For best results, make a double loop around the anti-roost insulator in the center groove of the insulator and fasten with a 1/16" cable clamp as shown in **Figure 37.**
7. Run the cable to the next insulator, attach a spring in the center groove at the anti-roost bracket and cut the cable at this point. The cable should be positioned in the insulator built into the top of each grill support along the feeder line.
8. Repeat this installation until the anti-roost cable is installed along the entire feeder line.

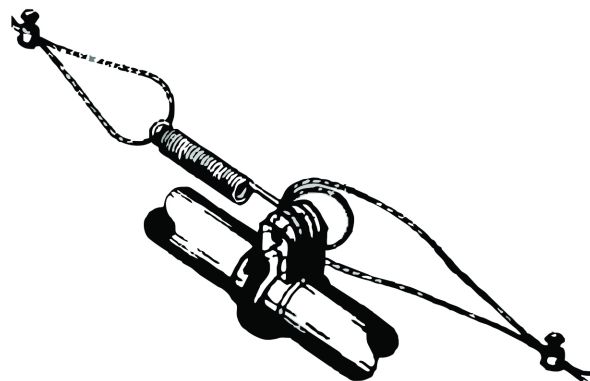
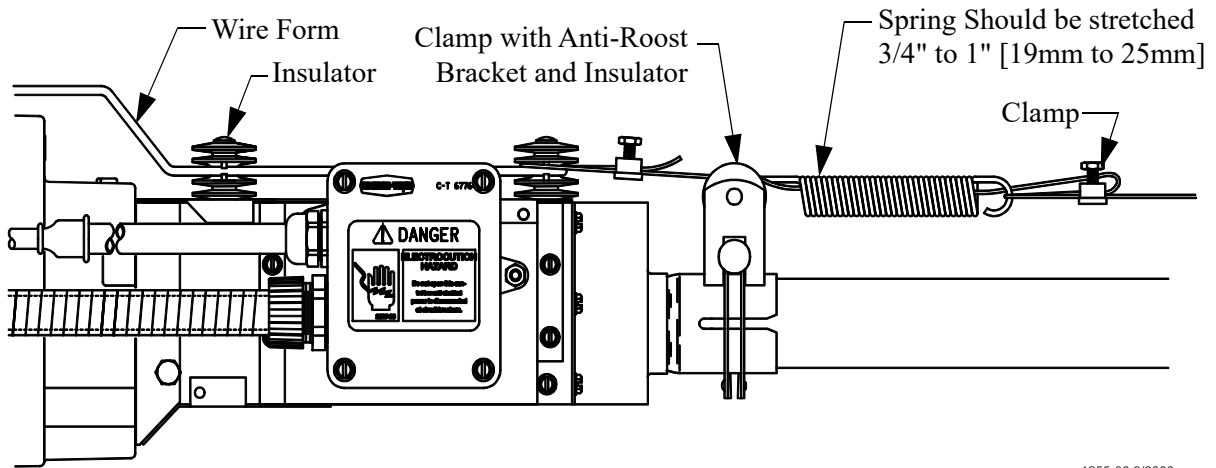

Figure 37. Anti-Roost Cable Mid-Line Connection

9. At the control unit, after clamping the cable to the spring, cut the cable about 8" to 10" [200 to 250 mm] longer than necessary. Feed the end of the cable through the center of the spring, around the first insulator on the control unit, and clamp the cable using the cable clamp supplied with the control unit. **see figure 38.** Install the wire form on the control unit insulators. Be sure the guard snaps into the retainers molded into the insulators. **see figure 38.**



1255-90 9/2000

Figure 38. Anti-Roost Installation at the Control Unit

10. Install the Poultry Trainer or Line Charger, as shown in **Figure 39.** The Poultry Trainer is used to power all Anti-Roost lines in a house.

- The Line Charger is used to power individual Anti-Roost lines in a house. **see figure 39.**
- Route the charger wire from the Poultry Trainer or Line Charger to the Anti-Roost system.
- Secure the Charger Wire to the Anti-Roost cable, using a cable clamp.

11. The **anti-roost system must** be on a **separate electrical circuit, allowing the system to be disconnected by a switch near the door.**

Remember, the anti-roost system should be **grounded through the poultry trainer.**

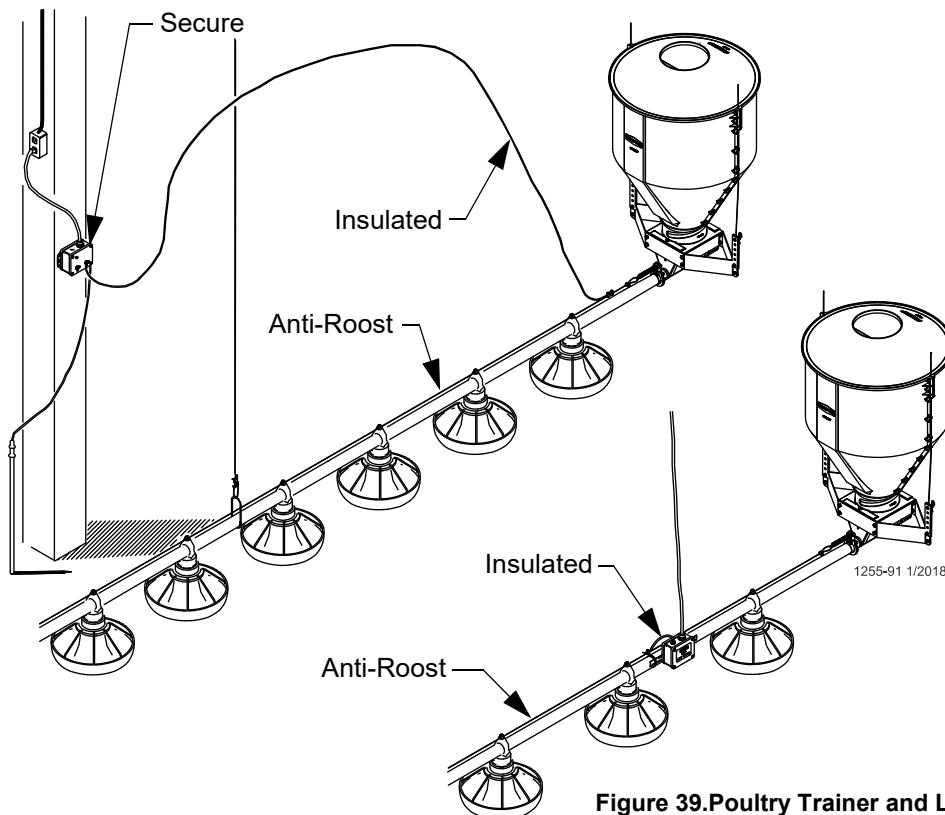
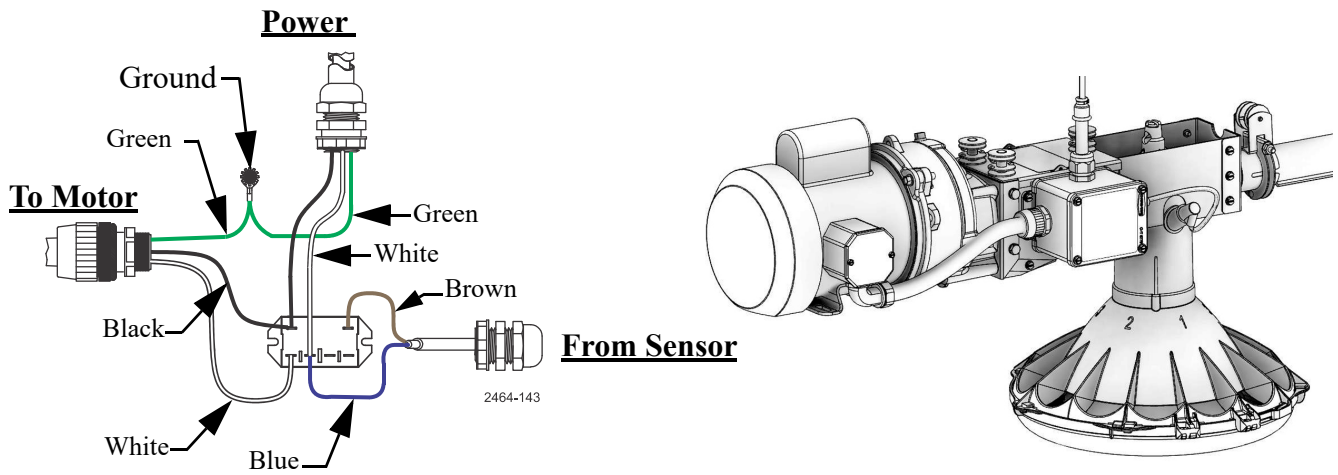

Figure 39. Poultry Trainer and Line Charger

Wiring

End Control with Proximity Switch Internal Wiring



Proximity Sensor Wiring Diagram

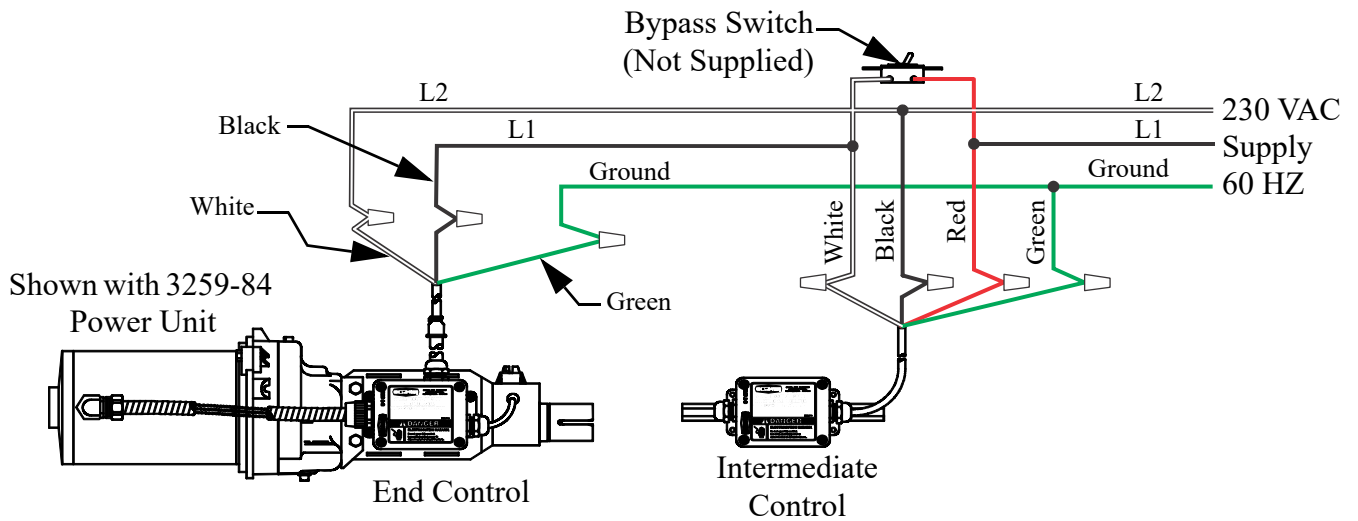

Mid-Line Control with Proximity Sensor Internal Wiring

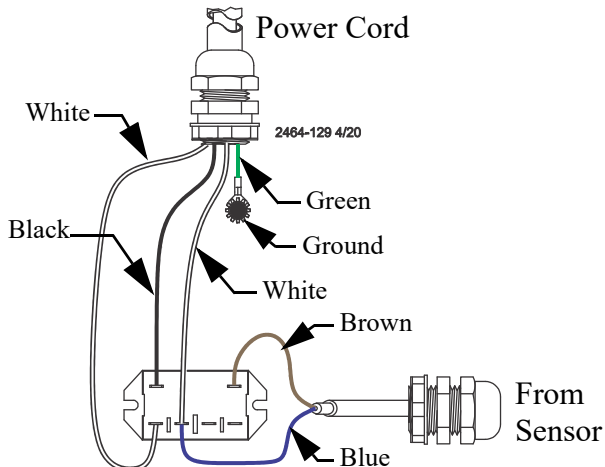

Mid Control with Proximity Sensor

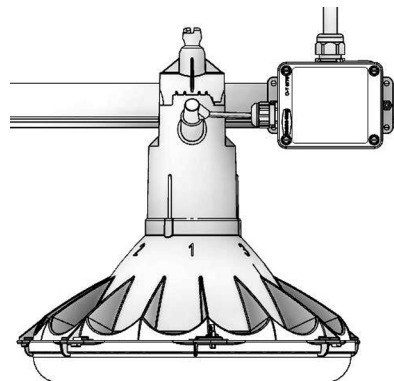

Electronic Sensor Three Phase Wiring

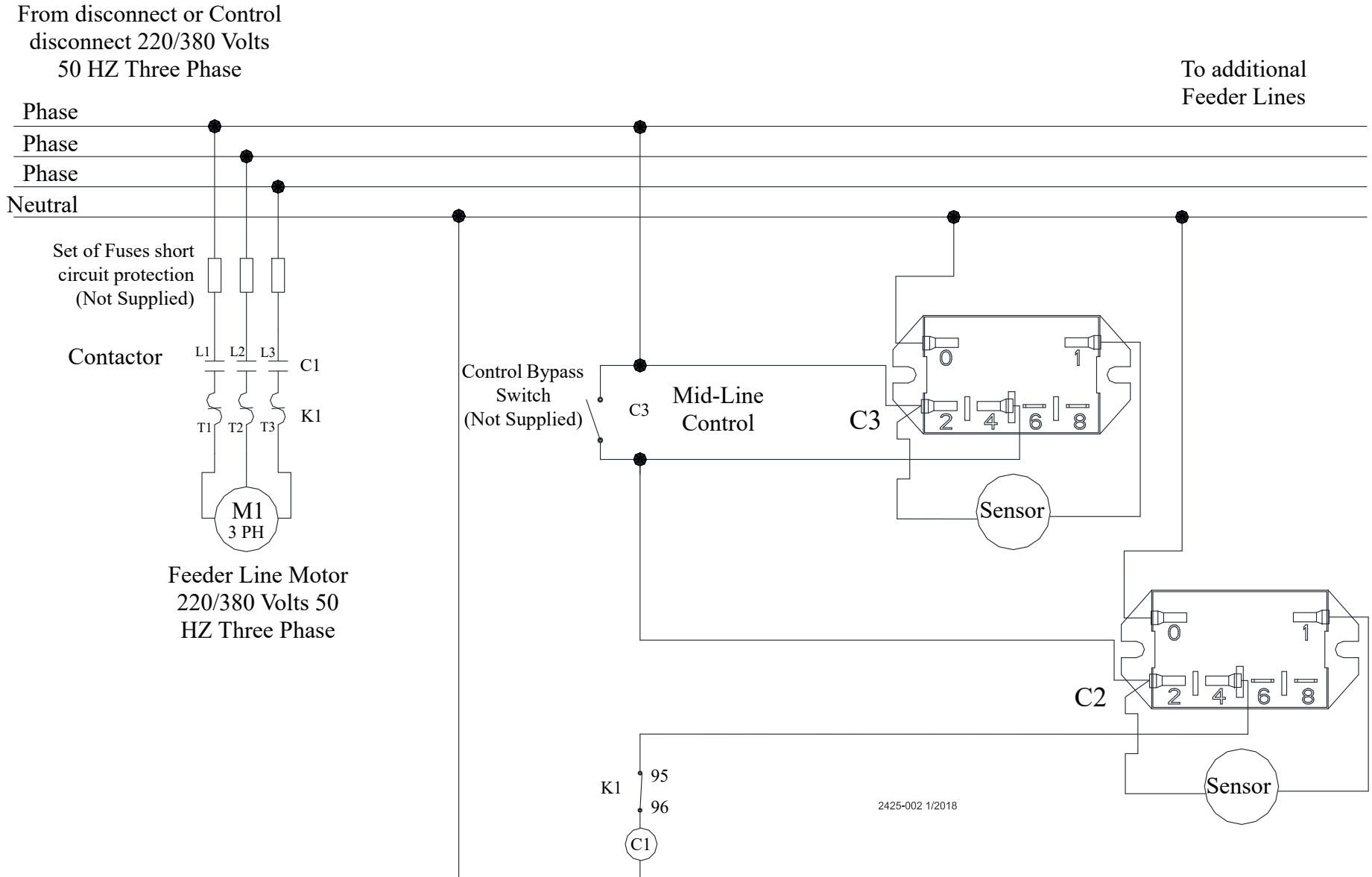

Power Unit Wiring

3259-144 Power (5051 Motor) Unit Wiring

There are two Manufacturers of the 5703 Motor. Wiring diagrams shown for both Manufacturers.

Nidec Motor Wiring
208/230 Volts AC
Clockwise Rotation

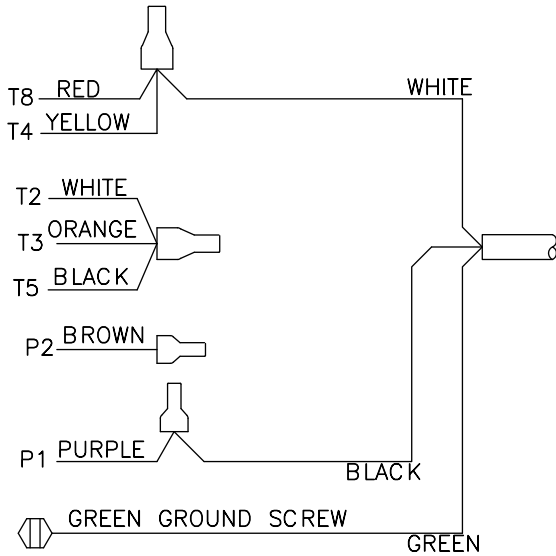

Regal (GE) Marathon Motor Wiring
208/230 Volts AC
Clockwise Rotation

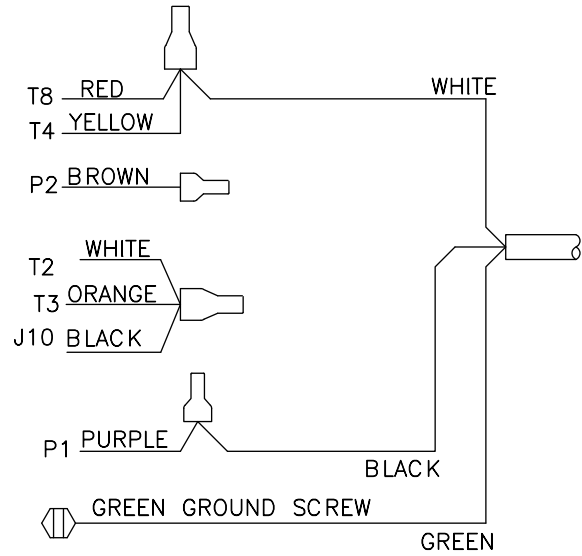

3259-153 Power Unit Wiring

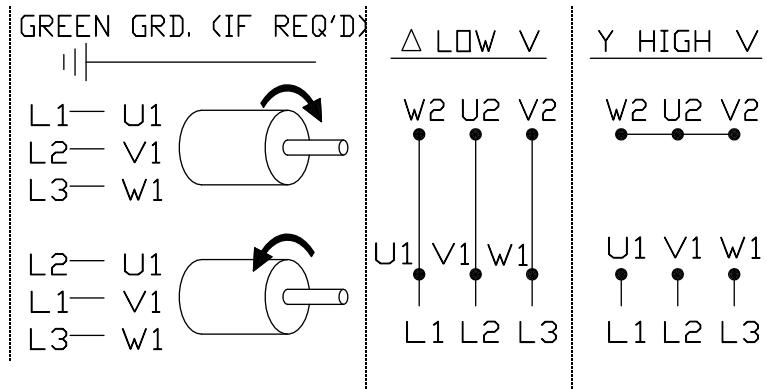

Troubleshooting

ALWAYS DISCONNECT POWER TO THE SYSTEM WHEN SERVICING OR MAINTAINING THE EQUIPMENT. FAILURE TO DISCONNECT POWER MAY CAUSE INJURY OR DEATH.

Service and maintenance work should be done by a qualified technician only.

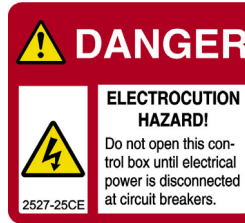

Problem	Possible Cause	Corrective Action
None of the feeder lines will operate	No power supplied to equipment	Replace burned fuses or reset circuit breaker Make sure voltage required is supplied
	Time Clock or relay defective	Replace Time Clock or relay
	Time Clock improperly programmed	Refer to Programming the Time Clock section and reprogram the Time Clock
Feeder line will not operate	Power unit cord not plugged in sufficiently to make contact	Check motor cord plug at control unit and control unit plug at outlet for connection
	Motor cord wires are broken at plug or where cord enters motor	Check cord for continuity Replace if defective
	Power Units thermal overload tripped	Push motor overload reset button to reset
	Control unit switch defective or out of adjustment	Adjust switch according to the Switch Adjustment Procedure in the maintenance section
Motor overloads frequently	Oil on new auger loads motor excessively when feed is carried for first time	Polish auger by running 50 lb (20 kg) increments of feed out to pans
	Inadequate power reaching motors	Check line voltage at the motors Check starting current draw at motors Wiring of adequate size is essential to feeder operation
	Object caught in the auger; motor runs, stalls, then auger spins in reverse	Check hopper boot, control unit and pan outlet holes for foreign objects Remove obstruction
Auger runs erratically	Frozen or cracked bearing at boot anchor	Replace bearing Slowly ease auger back into tube Be careful not to damage the bearing when reinserting the auger
	Insufficient stretch in auger	Shorten the auger
	Obstruction in the auger	Remove obstruction
Feeder Tube or boot wears out rapidly (Noisy feeder operation)	Auger is bent or kinked	Repair or replace damaged auger
	End of auger is riding up on anchor weldment	Auger must not be positioned over weld on anchor Check for bent or damaged auger
Oil leaking out of seals on power unit	Gearhead vent plug not installed	Replace plastic shipping plug with vent plug
	Defective gear head seal	Replace seal
Not enough feed supplied to the feeder pans	Insufficient time programmed on the time clock	Add more operating time to feeding period
	Feeder line control unit switch out of adjustment	Adjust switch according to the Switch Adjustment Procedure in the maintenance section

Maintenance

Floor Feeding System Maintenance

The KONAVI® Feeders require minimum maintenance. However, a routine periodic inspection of the equipment will prevent unnecessary problems.

Maintenance should be done by a qualified technician.

ALWAYS DISCONNECT POWER TO THE SYSTEM WHEN SERVICING OR MAINTAINING THE EQUIPMENT. FAILURE TO DISCONNECT POWER MAY CAUSE INJURY OR DEATH.

Gear Head Maintenance

Check the oil level in the gear heads at installation and every 6 months. The Pipe Plug, on the side of the gear head, indicates proper oil level. Add SAE 40W oil when necessary.

The oil in the Gearheads should be replaced every 12 months with new SAE 40W oil

1. Remove the bottom Pipe Plug to drain the oil. Discard used oil in accordance with local and national codes.
2. Wipe any debris off the magnet on the bottom Pipe Plug and reinstall. Remove the side Pipe Plug and (top) Vent Plug.
3. Set the power unit in the horizontal position.
4. **2-Stage Gearheads:** Add approximately 9 oz. (266 ml) of SAE 40W oil through top hole. This should be just enough oil to reach the side Pipe Plug.

3-Stage Gearheads: (3261-9, 3261-12, 3261-14): Add approximately 13 oz. (384 ml) of SAE 40W oil through top hole. This should be just enough oil to reach the side Pipe Plug. Install the side Pipe Plug and (top) Vent Plug.

Vent/Oil Fill Plug

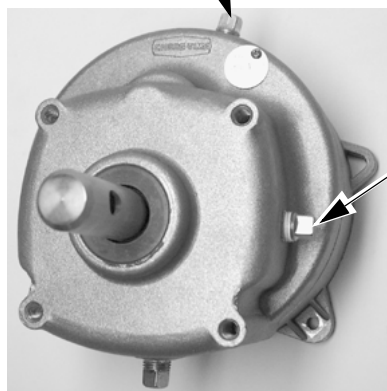

1660-22 1/2001

Check the oil level in Gearhead at installation.

Check the oil level every 6 months.

Check the oil level at the side plug if oil is needed use SAE 40W.

Oil capacity for the 2 stage gearhead is 9 oz [266 ml]

Oil capacity for the 3 stage gearhead is 13 oz [384 ml].
The oil should be changed every 12 months.

Figure 40. Gearhead Maintenance

Check equipment for loose hardware after the first flock and then every 6 months--including the Anchor Block. Tighten if necessary.

Proximity Sensor Adjustment

Sensitivity Timer: The Feeder Comes with the Sensitivity Timer adjustment Screw factory set and Glued in position. (Do not Adjust).

Time Delay: The Delay Time is Factory Set to 3 Minutes. See Figure 41.

To adjust the Time Delay:

- For less time — turn Time Delay Selector counter-clockwise.
- For more time — turn Time Delay Selector clockwise.

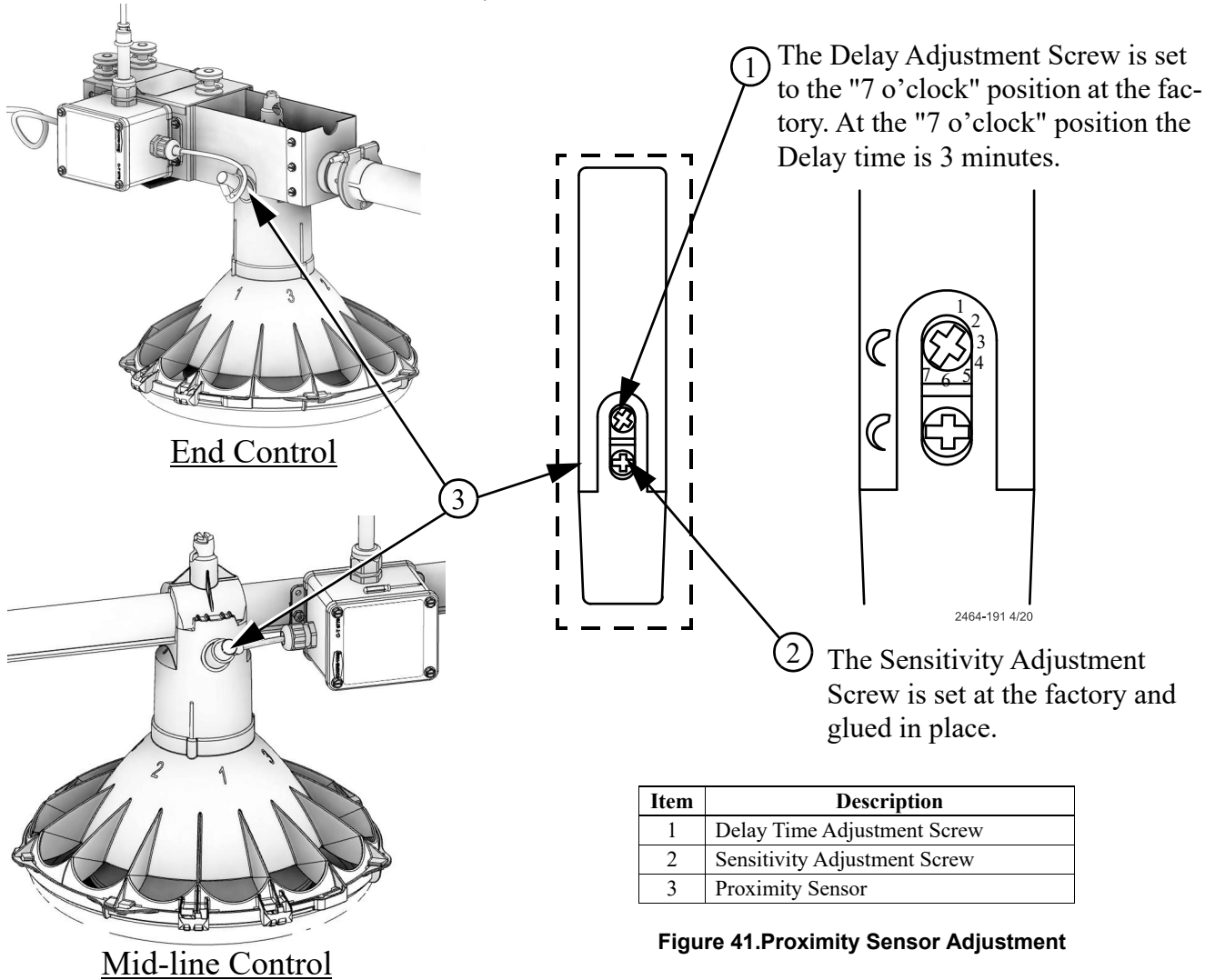

Item	Description
1	Delay Time Adjustment Screw
2	Sensitivity Adjustment Screw
3	Proximity Sensor

Figure 41. Proximity Sensor Adjustment

Feeder Line

Keep anti-roost cables tightly stretched. This increases the effectiveness of the electro-guard anti-roost system and keep the pans from being tilted when birds push against them.

Remove all feed from the feeder when there are no birds in the house and when the building is washed and disinfected.

Turn the feeders off prior to removing the birds from the house. This will allow them to clean the feed out of the pans.

If the system is not to be used for an extended period of time, remove all the feed from the feeder lines and feeder pans.

Disconnect power to the system to prevent accidentally starting the system.

If the system must be disassembled, extreme caution must be used to prevent injury from springing auger. Refer to **Figure 42**.

1. Disconnect power to the entire system.
2. Loosen the Tube Clamp on the bearing at the hopper end of the system. Remove the Tube Clamp and Bearing Retainer.
3. Pull the Anchor and Bearing Assembly and approximately 18" [45 cm] of auger out of the boot.

CAUTION: Stand clear...the auger may spring back into the tube.

BE CAREFUL WHEN WORKING WITH AUGER!

4. Place a clamp or locking plier securely on the auger to prevent it from springing back into the auger boot.
5. Loosen the setscrew in the bearing assembly shaft and remove the Anchor and Bearing Assembly from the auger.

To reinstall the Anchor and Bearing Assembly:

1. Insert the Anchor Assembly into the auger, guide the tip of the auger between the two roll pins in the center of the anchor. Continue to guide the auger until the tip of the auger hits the flat washer. Tighten the setscrews in the center of the anchor until they touch (See **Figure 42**.)
2. **Carefully** remove the locking pliers while holding onto the Anchor and Bearing Assembly and auger securely. **Slowly** ease the auger back into the tube. Use caution. If the auger is allowed to spring back, the bearing race may crack. Install the Bearing Retainer and fasten with a tube clamp. Keep the Bearing Retainer flush with the end of the anchor for safety.

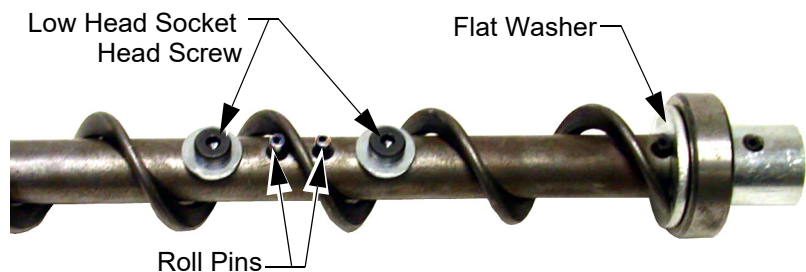
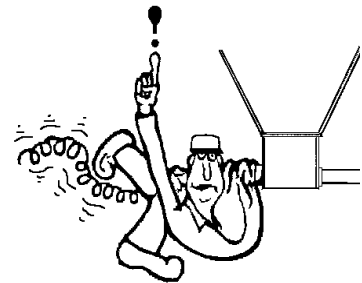

Figure 42. Auger and Anchor Bearing Connection



Power Lift Winch Maintenance

Refer to **Figure 43**.

Grease the winch every 6 months with 1 to 2 shots of common industrial or automotive grease.

Remove any feed build-up in the Safety Switch Boxes in the Control Units.

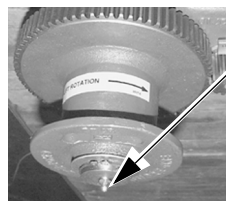

1660-24 6/2001

Figure 43. Maintenance to the Power Lift Winch

Grease the Power Lift Winch every 6 months with 1 to 2 shots of common industrial or automotive grease. **DO NOT OVER GREASE!**

It may be necessary to periodically re-tighten the shocker cable. Be sure to disconnect power to the shocker before servicing the equipment.

Operation

This section provides you with valuable information concerning feeder operation and management. It is important that you read this information and understand how the feeding system was designed to operate. Once you become familiar with the system, you may *custom operate* it to fit your individual needs.

Initial Start-up of the Feeding System

The Feeding System should be operated prior to birds being housed to make sure the installation is correct, the switches function properly, and to fill the feeder lines with feed.

It is common practice to use partial house brooding during the early days of Pullet production. For buildings that have the feeder split in the center (center hopper set-up), normally only the Pullet Feeders that are in the brood area are used during brood time. For buildings that have the hopper at one end, brooding can be done on the motor end or an optional mid line control pan(s) can be placed on the feeder line.

The feeder tubes and auger are supplied from the factory with a protective oil coating that will cause the system to deliver feed at a reduced rate. The oil coating will also create a larger load on the power unit (motor) until the system has been initially purged with feed, and becomes broken in.

To operate

1. Lower the Feed System until the Flood Windows fully open. **DO NOT** let the Suspension Cables go slack.
2. Apply power to the feeder lines to check the operation. Allow to operate empty for 1-2 minutes.

NOTE: For feeder lines that have mid line controls, the recommended bypass switch(s) are wired into the system for selection of partial or full house control. Select the switch so the mid line control is functional. As the feeder operates, the feed will stop at the mid line Control Pan.

3. With the shut-off slide on the feed bin boot closed, energize the Flex-Auger® fill system. After operation of approximately 1-2 minutes, open the boot slide 1/2 way to allow feed to be conveyed to the feeders.
4. Once feed begins to be dispensed into the feed hopper(s), manually shut-off the fill system.
5. Apply power again to the feeder lines. Operate the fill system manually to dispense approximately 50 lb. [23 kg] increments of feed into the feed hopper(s). Allow the feed hopper to become empty for 30 seconds between each increment to reduce load on the feeder motor. Continue this procedure until feed has been dispensed to all the feeder pans. When the feed reaches the control pan, the feeder line will be shut-off.
6. Once the feeder lines have been initially filled with feed, manually dispensing feed in 50 lb. [23 kg] increments will no longer be necessary. The shut-off slide on the Flex-Auger® fill system may be completely opened. Refer to the Flex-Auger fill system Operator's Manual for information when multiple feed bins are used.

General Operation of the KONAVI® Pullet Feeders

These recommendations are the guideline to aid producers with the use of the feeding system. With experience a feeding program will be developed to enhance the feeding systems performance. Several factors such as feed content, type of birds, climate, lighting programs, and etc. may dictate change from these recommendations.

The KONAVI® Pullet Feeders have feed flood windows which allow the Feeder Pan, when lowered to the floor, to be filled with feed for the brooding of young birds. Start young birds with the feeder line lowered so the feed pans are resting on the floor and the feed flood windows are completely open. **DO NOT** lower the system far enough to let the Suspension Cables go slack.

With the feeders lowered to the floor and the feed flood windows open, the operation of the feeder will allow a high level of feed to be placed into the feed pans making it easy for the birds to find feed, adapt to the feeder, and begin to eat.

Do not operate the feeding system on automatic (full demand feed) when the feed windows are open. Chore-Time recommends opening the feed windows for the first 10 to 12 days (max). The feeders will need to be operated at least 2 times a day for the first 5 days, and thereafter, 3 times a day or more as needed, while the windows are open. If it is not possible to operate the feeder manually 1-3 times a day during the brood time (windows open), then a time clock should be utilized to limit the number of times and length of time the feeder can operate.

After 10-12 days raise the Feed Lines until there is roughly one inch [2.54 cm] gap between Floor and Feeder Pan. It should be high enough that all Pans can swing slightly. Generally, keep the Feed Pan lip at bird chest height throughout the rearing period.

Use the suspension system to raise the feeder(s) line. As the feeder is raised the feed flood windows will close. Continue raising the feeder lines until the feed pans just begin to clear the floor or litter.

Feeder Pan Setting

The Feeders should be set on the #1 position for most applications. The adjustment settings are easy to understand and change. Setting numbers are embossed on both sides of the grill so they may be easily seen from either side of the feeder line. (See Figure 44.) Feed texture and consistency, type of bird, or other variables may make it necessary to change to another feed setting position. The combination of proper pan height, feeder setting, and feeder operation will result in optimum feeder performance. (See Figure 46.) The operator will learn what performs best for his/her situation with experience.

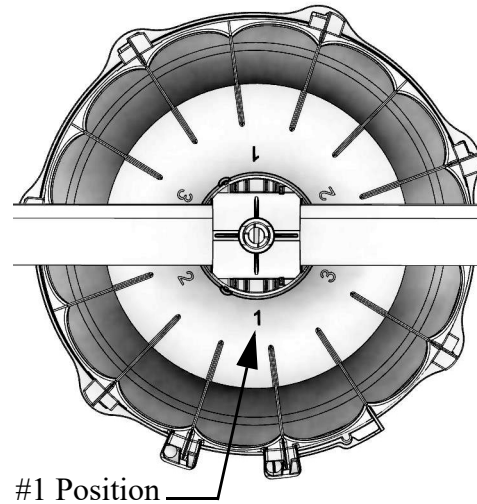

Figure 44. Feeder Pan Setting

Feed Volume

Chore-Time recommends grow-out crumble feed at 45lb/ft² density. If using 45lb/ft² the following settings apply. (See Figure 45.)

See “Manufacturer’s Recommendations: Birds per Pan” on page 7 for birds per pan recommendations.

Pan Setting	lbs. per pan
1	1.7
2	2.0
3	2.3

Figure 45. Feeder Pan Setting

End Control Pans

At installation time, the end control was placed to 10 feet [3 m] from the end of the building to allow the birds access around the end of the feeder line.

The End Control Pan should be set to the #1 position. This ensures that the Feed will be consumed in the Control Pan, calling for feed to the rest of the Feed Line.

Mid Line Control Pan

The Mid Line Control is placed on the feeder line when partial house brooding is desired. It is important the mid line control be installed at least 2 feeder pans away from the curtain or partition so the birds will activate the feeder line. The feed setting for the mid line control should be the same as the rest of the feeder pans on the feeder line. A toggle switch or disconnect is used to bypass the power to the mid line control. This allows the mid line control to serve as a standard feeder after brooding. The feeder can be changed from full house operation to partial house brooding with the activation of the switch.

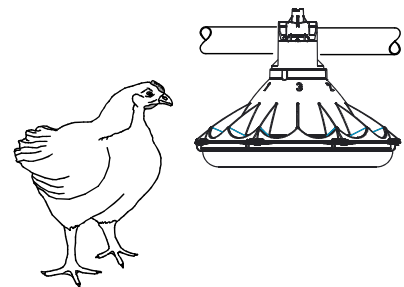

Figure 46. Feeder Pan height adjustment

Electro-guard Operation

The electro-guard chargers should be operated on a separate electrical circuit so the anti-roost system can be shut off using a switch next to the entrance door when someone enters the building. Birds are less likely to become wild and flighty if the anti-roost is off when people are in the building.

Parts List

150# Plastic Hopper (49268)

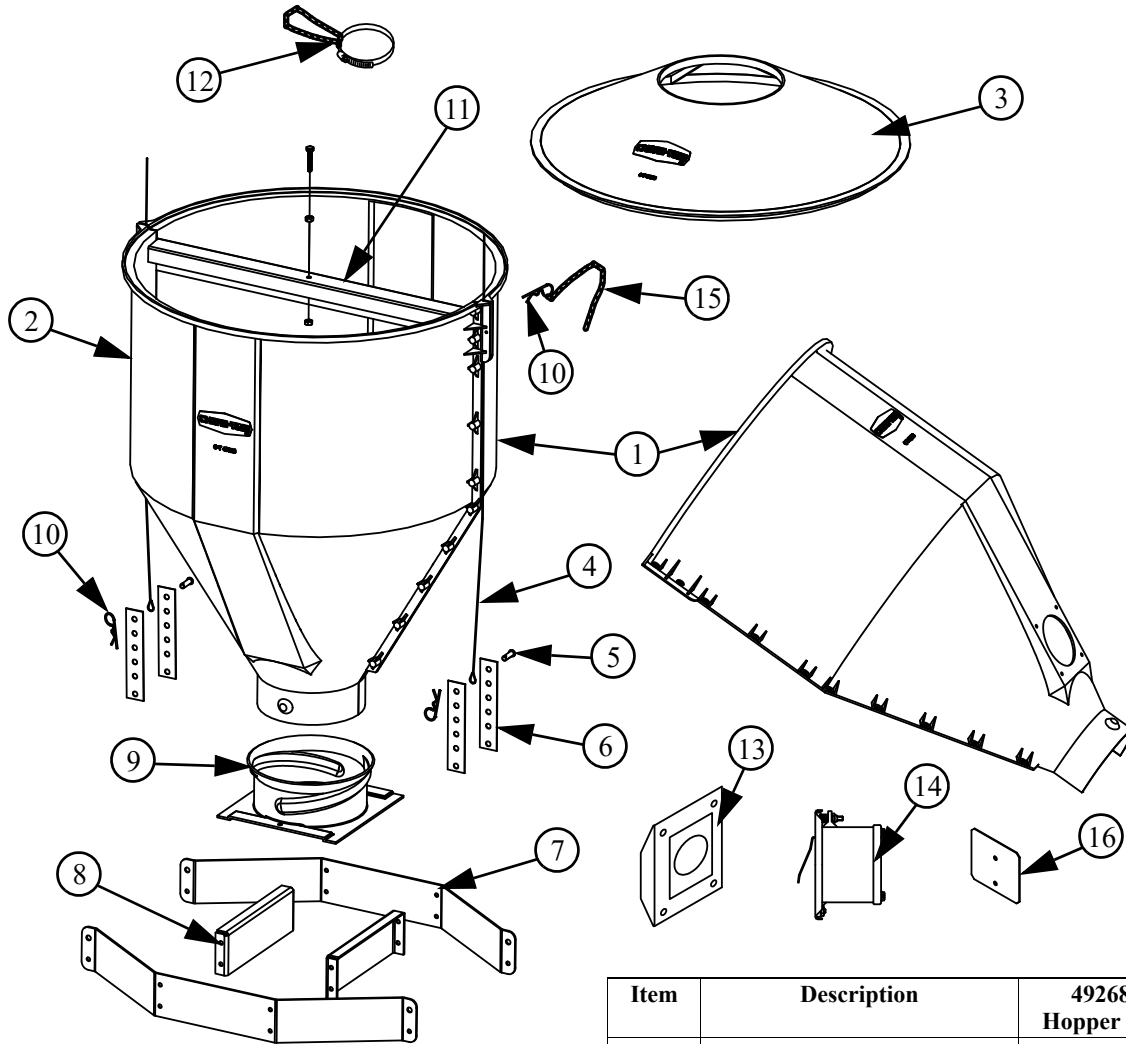

Item	Description	49268 Hopper Kit
1	Machined Hopper Half	49270
2	Plastic hopper half	49028
3	Hopper cover	48675
4	Support cable assembly	2809-3
5	Clevis pin	2797-1
6	Boot adjuster bracket	2706
7	Suspension angles	48679
8	Suspension brace	48680
9	Twist lock collar	49041
10	Hair pin	2664
11	Cross brace	49029
12	Drop tube support	14367
13**	Diaphragm Assembly	7900
14**	Lower Hopper Switch	7840
15*	Chain	2128
16	Switch Backup Plate	50966

*Item must be ordered in either 100 ft or 250 ft quantities, 2128-100 is 100 ft and 2128-250 is 250 ft.
 **Included with 8798 Switch Assembly See "8798 Switch Assembly" on page 46.

8798 Switch Assembly

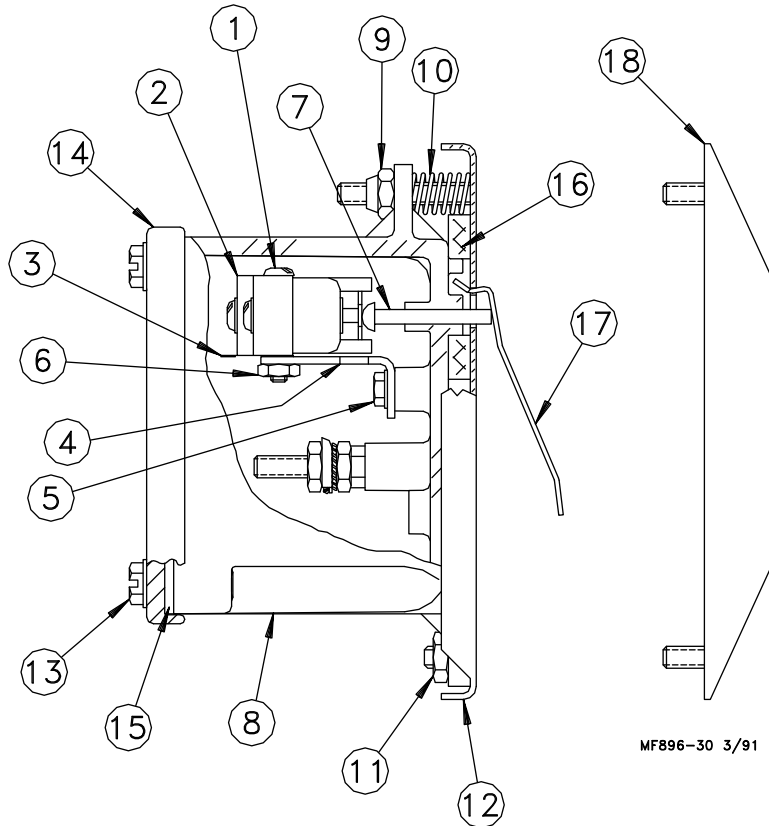

MF896-30 3/91

Item	Description	Part No.
1	6-32 x 7/8" Rd. Hd. M.S.	1921
2	SPDT Actuator Switch	7114
3	Switch Insulation	1907-5
4	Switch Bracket	7068
5	#6 x 3/8" Slot Wash. Hd. Screw	6782
6	6-32 Hex Nut	771
7	Pin	8757
8	Switch Box	7841
9	10-32 Hex Lock Nut	6963
10	Spring	6972
11	10-32 Hex Nut	4297
12	Mounting Plate	7908
13	#10 Twin Helix Screw	6980
14	Switch Box Cover	6776
15	Gasket	6777
16	Gasket	6968-1
17	Paddle	7896
18	Diaphragm Assembly	7900
--	Deflector	28281

200# Hopper Components

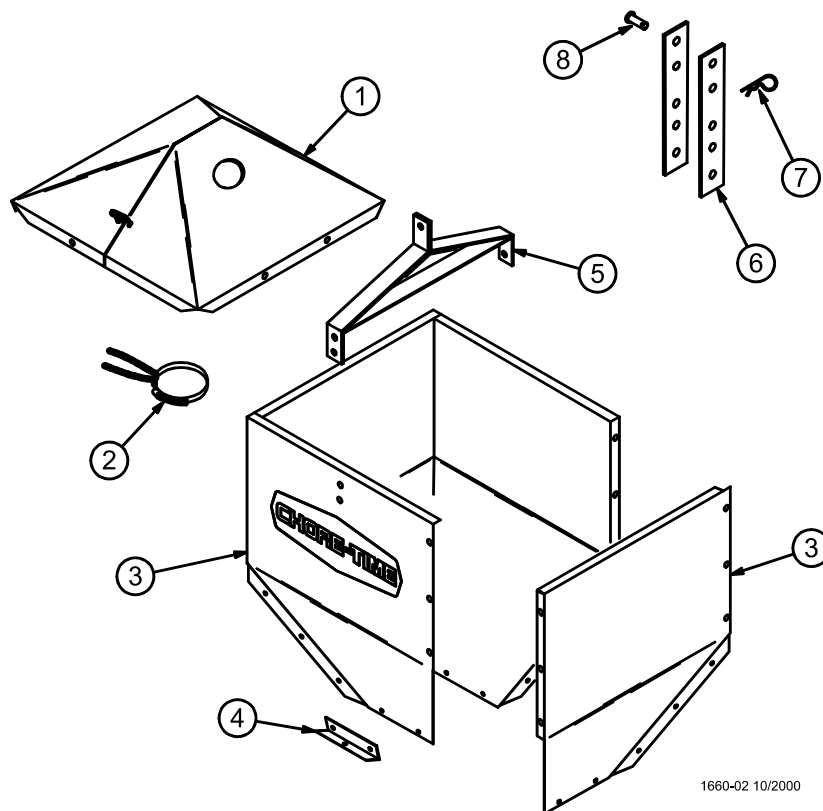

		7941	28358
		Hopper Assembly	Hopper Ass'y with cover
Item	Description	Part No.	
1	Hopper Cover	--	28206
2	Tube Support Assembly	14367	14367
3	Hopper Side	2680	2680
4	Boot Hanger	2671	2671
5	Hanger Bracket Assembly	2681	2681
6	Adjustment Bracket	2706	2706
7	Hair Pin	2664	2664
8	Clevis Pin, 5/16 x 1"	2797-1	2797-1

100 # Hopper Components

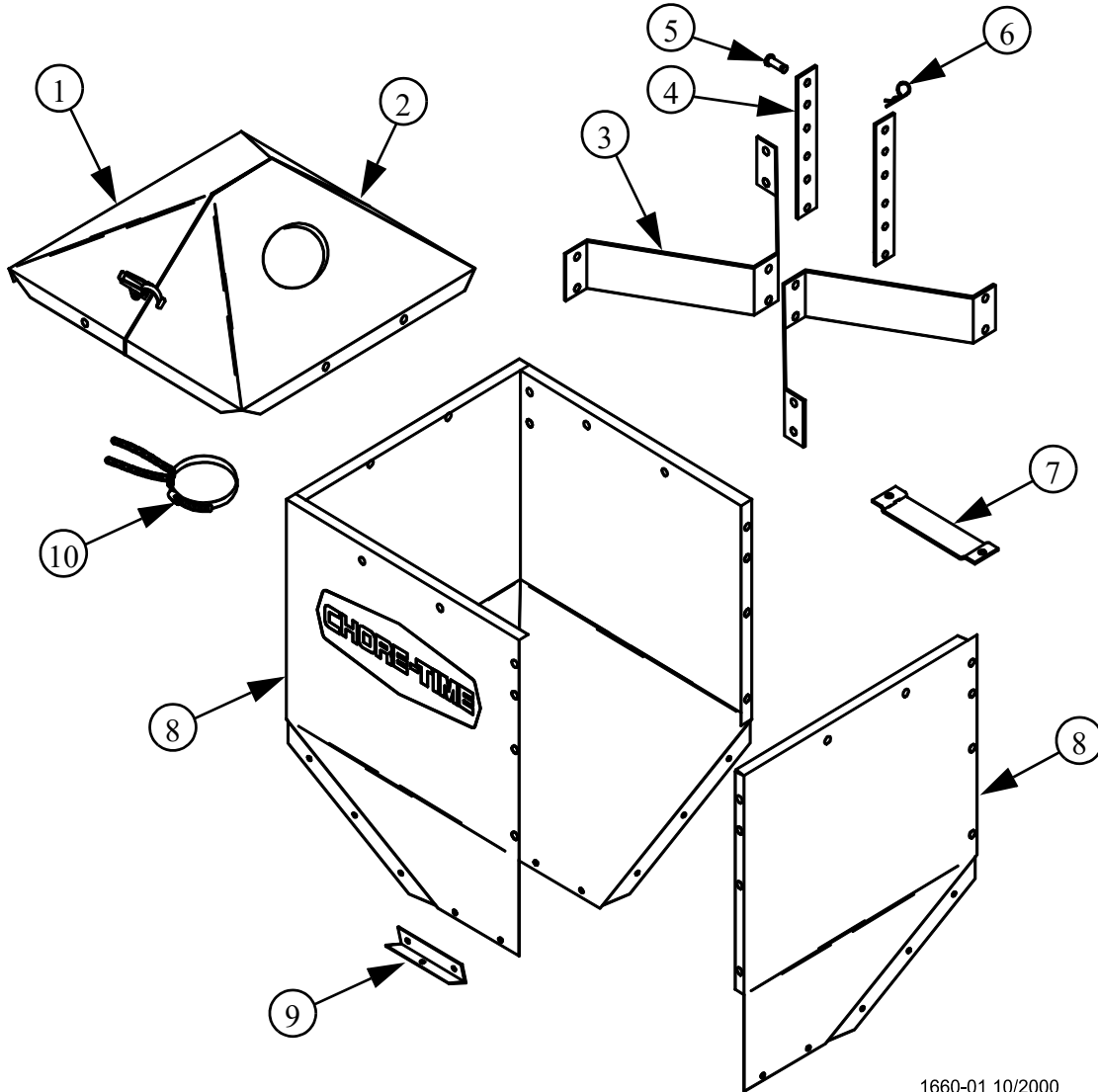

1660-01 10/2000

		28210 100 lb. Hopper Cover Ass'y.	28220 100 lb. Hopper Assembly (No Cover)	28240** 100 lb. Hopper & Cover Assembly
Key	Description	Part No.		
1	Hopper Cover (w/o hole)	28211	--	
2	Hopper Cover (w/ hole)	28212	--	
3	Hopper Hanger	--	28165	
4*	Adjustment Bracket	--	2706	
5*	Clevis Pin, 5/16" x 1"	--	2797-1	
6*	Hair Pin	--	2664	
7	H.L.C Mounting Bracket	--	28267	
8	Hopper Side (w/ hole)	--	28164	
9*	Boot Hanger	--	28168	
10*	Tube Support Assembly	--	14367	
--	100 lb. Hopper Cover Ass'y.	--	--	28210
--	100 lb. Hopper Ass'y	--	--	28220

*Included in parts package (part number 28167)

Hopper Mount Bracket

Part Number 49358 - Hopper Suspension Kit

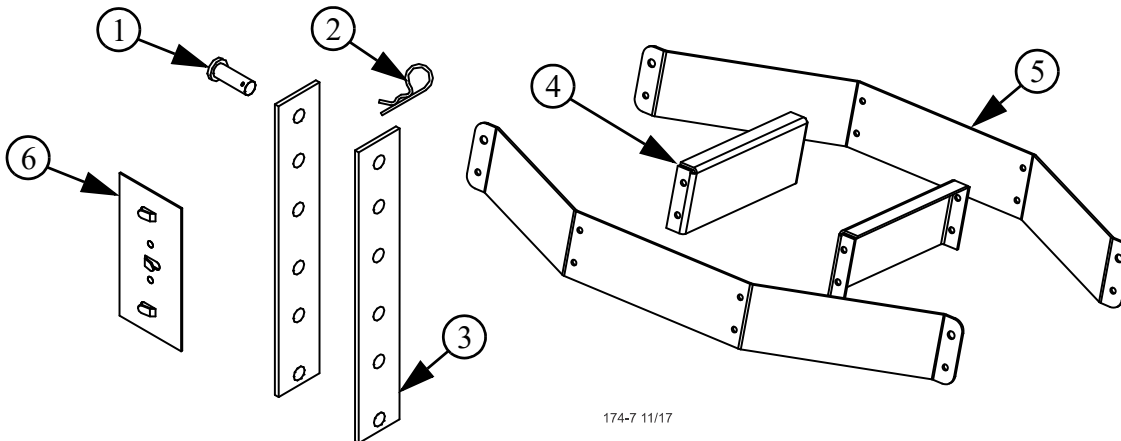

174-7 11/17

Item	Description	Part No. Single Boot Kit	Part No. Twin Boot Kit
1	Clevis Pin, 5/16" x 1"	2797-1	2797-1
2	Adjustment Bracket	2706	2706
3	Hair Pin	2664	2664
4	Suspension Brace	48680	48680
5	Suspension Angle	48679	48679
6	Cable Guide	34573	34573

Single Boot Components Part No. 6822

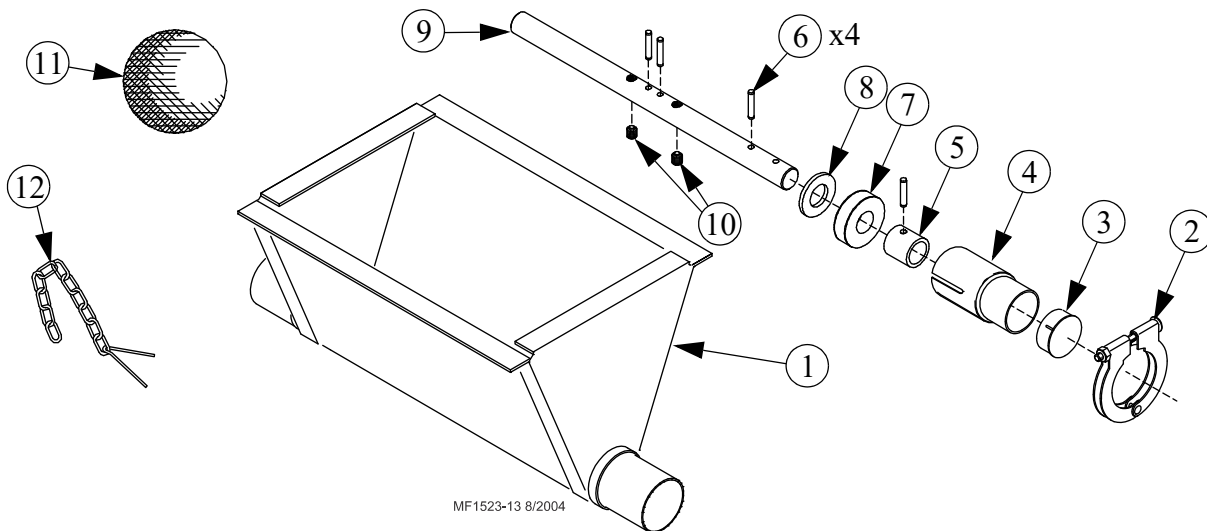

MF1523-13 8/2004

Item	Description	Part No.
1	Boot Weldment	3760
2	Tube Clamp	24063
3	Cap	29373
4	Outlet Tube	4556
5*	Sleeve	5648
6*	3/16 x 1" Pin	2960-1
7*	Bearing	2689
8*	Washer	2955-14

Item	Description	Part No.
9*	Anchor	38540
10*	Setscrew	47867
11	Cannonball	3531
12*	Latch Pin Ass'y	2683
--	Danger Decal	2527-9

*These parts included in p/n 39372 Anchor and Bearing Assembly

Twin Boot Components Part No. 6824

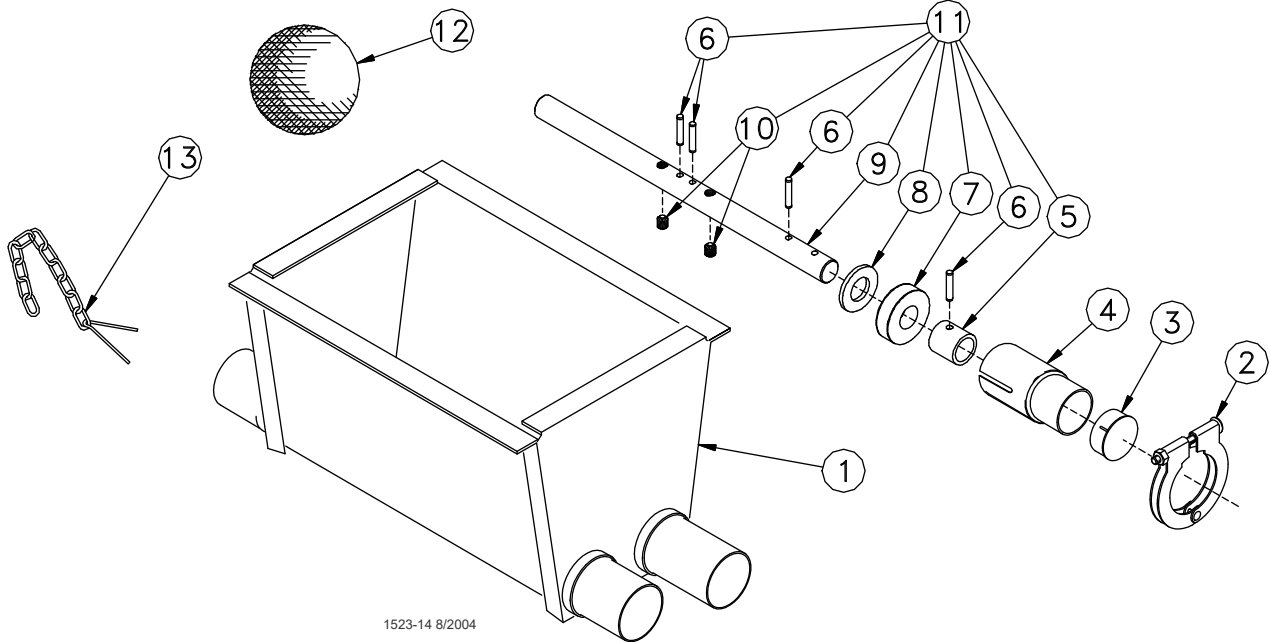

1523-14 8/2004

Item	Description	Part No.
1	Boot Weldment	3760
2	Tube Clamp	24063
3	Cap	29373
4	Outlet Tube	4556
5	Sleeve	5648
6	3/16 x 1" Pin	2960-1
7	Bearing	2689
8	Washer	2955-14

Item	Description	Part No.
9	Anchor	38540
10	5/16-18x7/8" Sock Hd Screw	47867
11	Anchor and Bearing Ass'y	39372
12	Cannonball	3531
13	Latch Pin Assembly	2683
--*	Jumper Wire Kit	5960
--	Danger Decal	2527-9

*The Jumper Wire Kit includes an insulated piece of High-Voltage Wire (part no. 28994) and (2) cable clamps.

Feeder Tubes

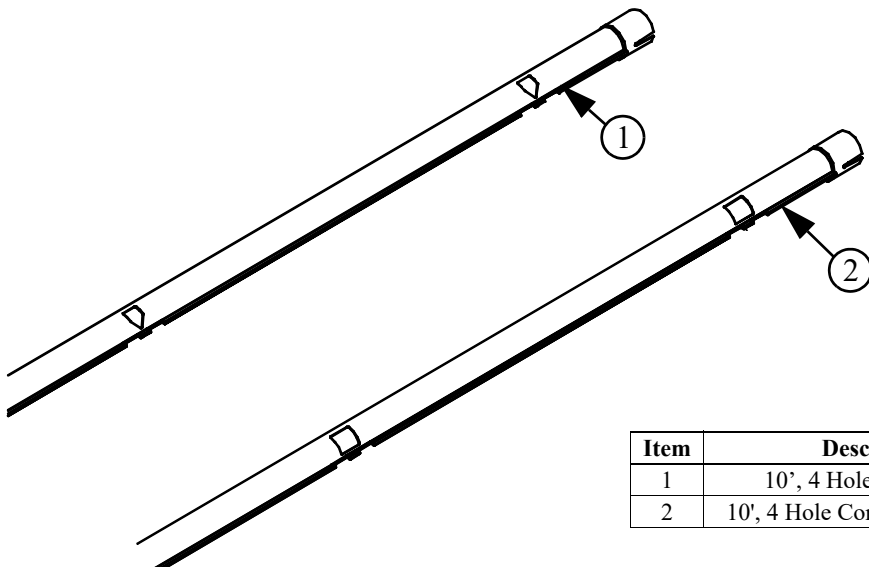

Item	Description	Part No.
1	10', 4 Hole Feeder Tube	6854-4
2	10', 4 Hole Control Feeder Tube	43006-4

Feeder Line Components

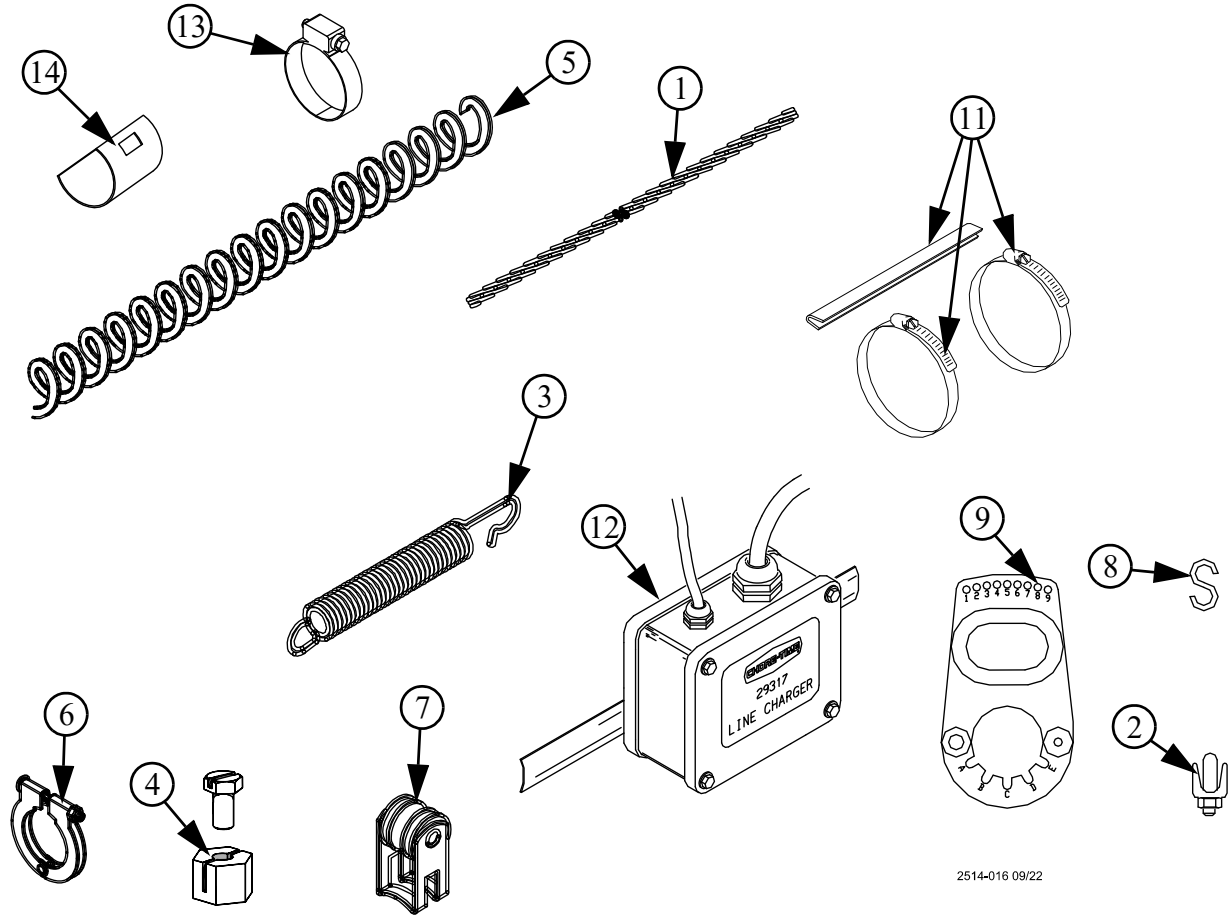

2514-016 09/22

Item	Description	Part No.
1	1/16" Cable	1922
2	3/16" Cable Clamp	1213
3	Spring	7551
4	1/16" Cable Clamp	1826
5*	Auger	6820-0
6	Tube Clamp	24063
7	Anti-Roost Bracket	24060
8	Small "S" Hook	723
9	Hanger Assembly	7604
10	Grommet	14899
11	Anti-Swing Clamp Kit	14485
12	Line Charger (110v)	5458
	Line Charger (220v)	5459
13**	Adjustment Clamp	3527
14**	Tube Closure	9126

*Round up to the nearest 10'. Auger lengths from 50' to 500'.
 Example: 6820-200 would be a 200' roll of 6820 Auger.
 **These parts may be ordered as a kit under part no. 14585

KONAVI® Breeder Feeder Assembly (Part Number 57452)

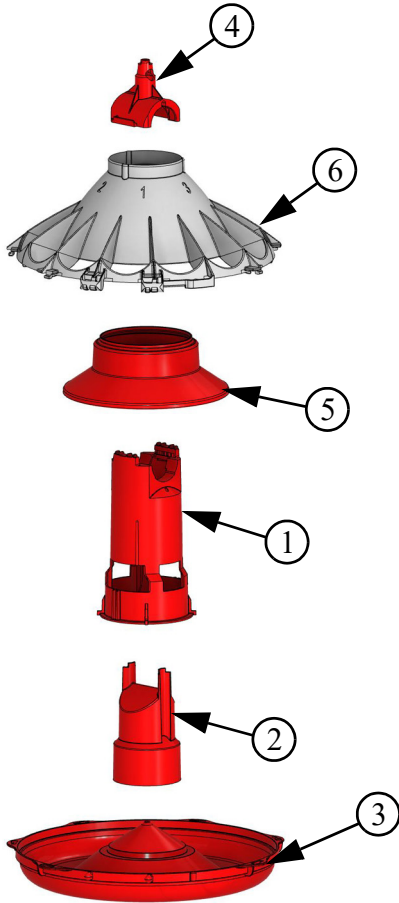

Item	Description	Part No.
1	Konavi Breeder Cone	56756
2	Konavi Breeder Restrictor	57354B
3	Konavi Breeder Pan	57395
4	Konavi Breeder Cap	56753
5*	Konavi Breeder Skirt	57355
6	Konavi Chick Excluder	57396

Power Winch (Part No. 47687)

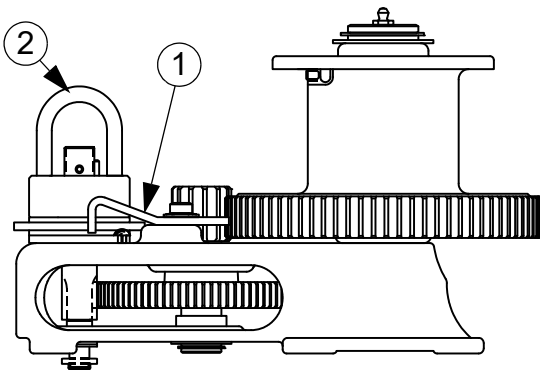

Item	Qty.	Description	Part No.
1	1	Pawl	47687-5
2	1	Input Shaft Assembly	47687-1

Power Unit Assemblies

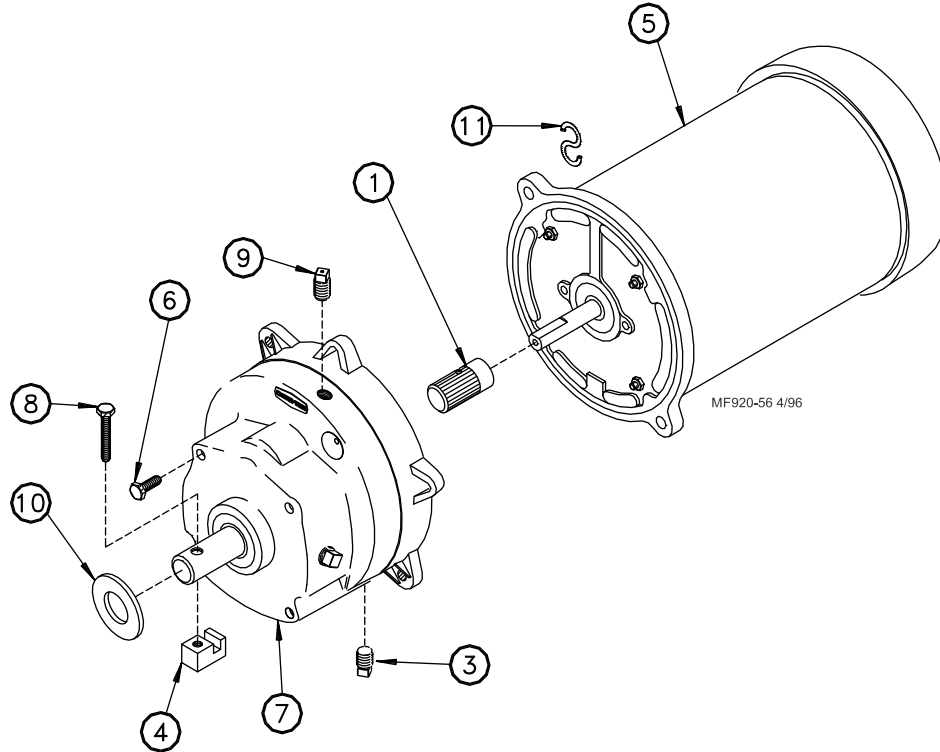

Item	Description	3259-144 Part No.	3259-153 Part No.
1	Pinion Assembly	5052	5052
2	----	----	----
3	Pipe Plug (magnetic)	30160	30160
4	Driver Block	4642	4642
5	Motor	5051	28034EUR
6	5/16-18x1.25 Hex HD Screw	38163	38163
7	Gearhead	3261-17	3261-17
8	1/4-20x1-1/2 Socket Hd Screw	5083-8	5083-8
9	Vent Plug	3516	3516
10	Flat Washer	1484	1484
11	"S" Hook	2805	2805
--	Cord Assembly	----	----
--	Connector (Romex)	----	----
--	Connector (90 Degree)	----	----

Power Unit Assembly Part Numbers

Part No.	HP	RPM	Phase	Hz	Voltage
3259-144	3/4 HP	696 RPM	Single Phase	60 Hz	230
3259-153	3/4 HP	696 RPM	Three Phase	50/60 Hz	230

8798 Switch Assembly

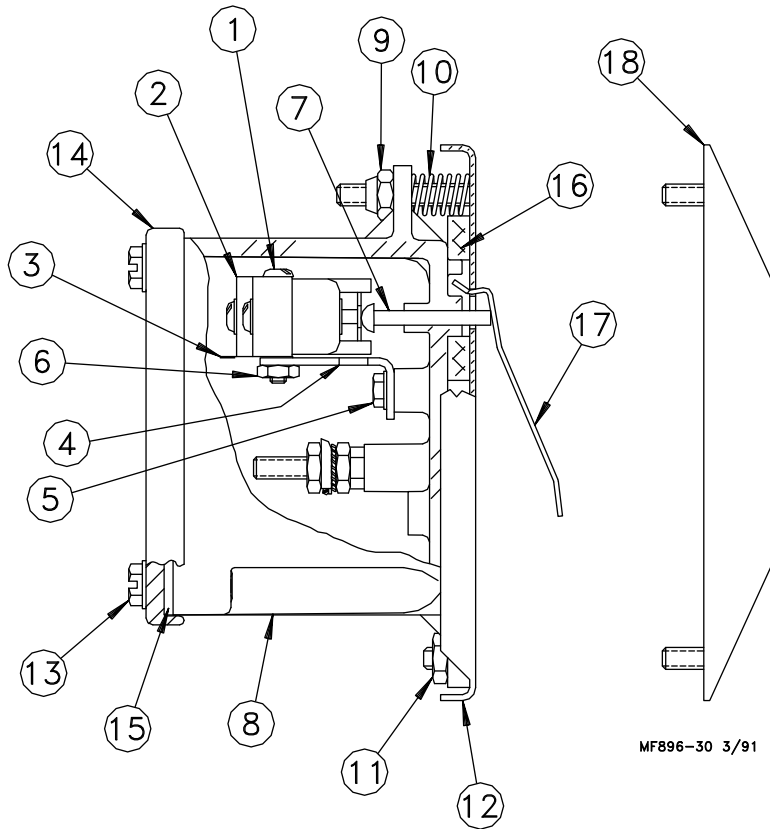

MF896-30 3/91

Item	Description	Part No.
1	6-32 x 7/8" Rd. Hd. M.S.	1921
2	SPDT Actuator Switch	7114
3	Switch Insulation	1907-5
4	Switch Bracket	7068
5	#6 x 3/8" Slot Wash. Hd. Screw	6782
6	6-32 Hex Nut	771
7	Pin	8757
8	Switch Box	7841
9	10-32 Hex Lock Nut	6963
10	Spring	6972
11	10-32 Hex Nut	4297
12	Mounting Plate	7908
13	#10 Twin Helix Screw	6980
14	Switch Box Cover	6776
15	Gasket	6777
16	Gasket	6968-1
17	Paddle	7896
18	Diaphragm Assembly	7900
--	Deflector	28281

14485 Anti-Swing Clamp Kit

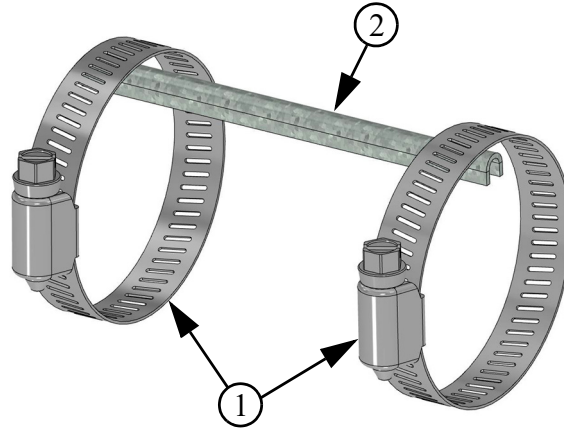

Item	Part No.	Description
1	3527	1.875 Hose Clamp
2	14484	Locking Pin

56 KONAVI® Proximity Sensor End Control 57425

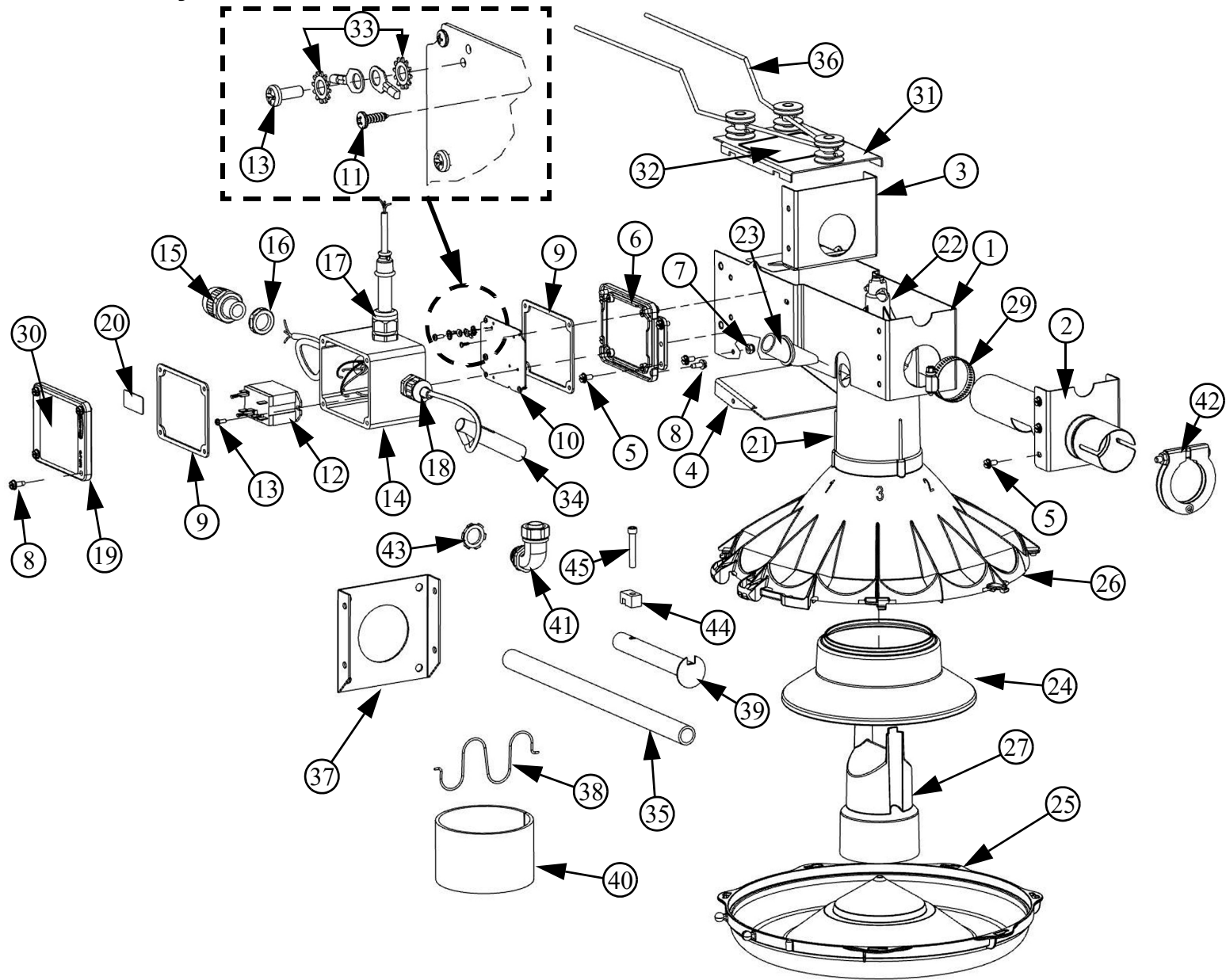

Item	Part No.	Description
1	56576	Control Sensor Body
2	56579	Support Tube Assembly
3	48081	Center Divider
4	48086	End Control Bottom Cover
5	4416-7	10-24 Hex Screw
6	6956	Box Mounting Cover
7	34019	10-24 Nylon Hx Lock Nut
8	28075	#10 x.5 Screw
9	6777	Switch Box Gasket
10	52316-2	Control Panel Relay Mount
11	35493	4-24 x /375 Phil PH Screw
12	28904	Relay
13	34660	6-32 x .375 SFTP Screw
14	42627-12	General Purpose Box
15	26980	Liquid Tight Fitting
16	43662	.50 Conduit Lock Nut
17	24685	Water Tight Connector
18	23779	Liquid Tight Connector
19	6776	Terminal Box Cover
20	2526-377	Date of Manufacture Decal
21	57430	Konavi Breeder Cone
22	56753	Konavi Breeder Cap

23	56084	Sensor Switch Holder
24	57355	Konavi Breeder Skirt
25	57395	KONAVI® Breeder Pan
26	57396	Chick Excluder
27	57354B	Konavi Breeder Restrictor
29	3527	Hose Clamp
30	2529-1216	Konavi Prox Control Decal
31	48491	Top Cover w/Insulators
32	2527-9	Danger Decal
33	305	#10 Ext. Lock Washer
34	56275	Dol 26 Sensor
35	26982-1	1/2x14 Flex Conduit
36	2798	Anti-Roost Guard
37	4188	Anchor Plate
38	48511	Lock Spring
39	44794	Drive Tube Weldment
40	56081	Konavi Cut Sleeve
41*	23810	1/2" Ell Liquid Tight Connector
42*	24062	1.75" Tube Clamp
43*	3357	.50 Conduit Lock Nut
44*	4642	Drive Block
45*	5083-8	1/4-20 Socket Hd. Cap Screw
*Included in 43233 End Control Hardware Package		

58 KONAVI® 57453 Proximity Sensor Mid Line Control

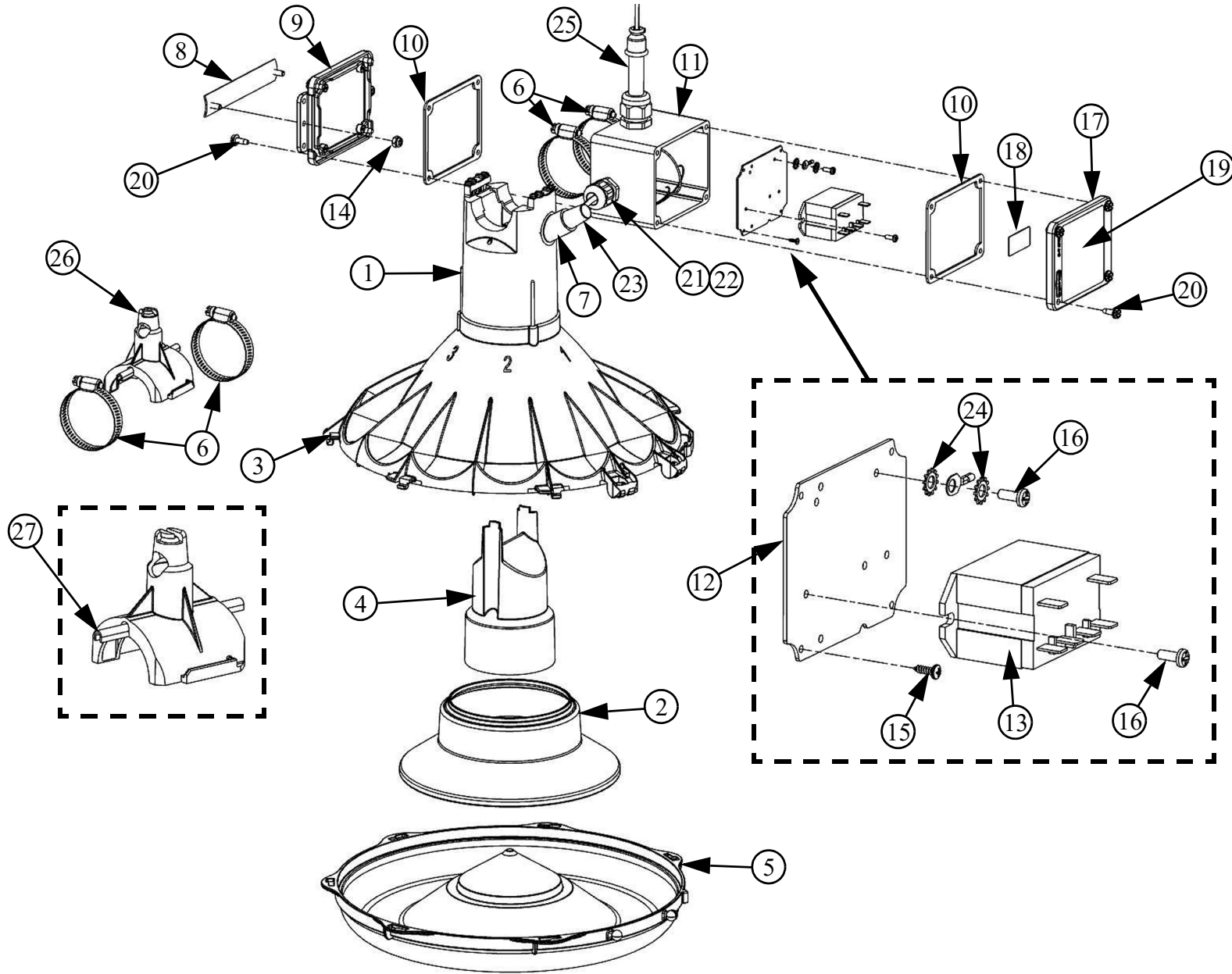

Item	Part No.	Description
1	57430	Konavi Breeder Cone
2	57355	Konavi Breeder Skirt
3	57396	Chick Excluder
4	57354B	Konavi Breeder Restrictor
5	57395	KONAVI® Breeder Pan
6*	3527	1.875 Hose Clamp
7	56084	Switch Holder
8	52315	Mounting Bracket
9	6956	Mounting Terminal Box Cover
10	6777	Switch Box Gasket
11	42627-13	General Purpose Box
12	52316-2	Control Panel Relay Mount
13	28904	Relay
14	34019	10-24 Nylon Hx Lock Nut
15	35493	4-24 x /375 Phil PH Screw
16	34660	6-32 x 3/8 Phil. Pan. Hd. Screw
17	6776	Terminal Box Cover
18	2526-377	Date of Manufacture Decal
19	2529-1217	Konavi Breeder Mid Line Decal
20	28075	#10 x .5 HXWH Screw
21	23779	Liquid Tight Connector
22	43662	.50 Conduit Lock Nut
23	56275	Proximity Sensor
24	305	#10 Ext. Lock Washer
25	4999-114	Cord Assembly
26	56753	Konavi Breeder Cap
27*	14484	Locking Pin
*Two Clamps and Locking Pin Included in 14485 Anti-Swing Clamp Kit.		

Miscellaneous Suspension Components

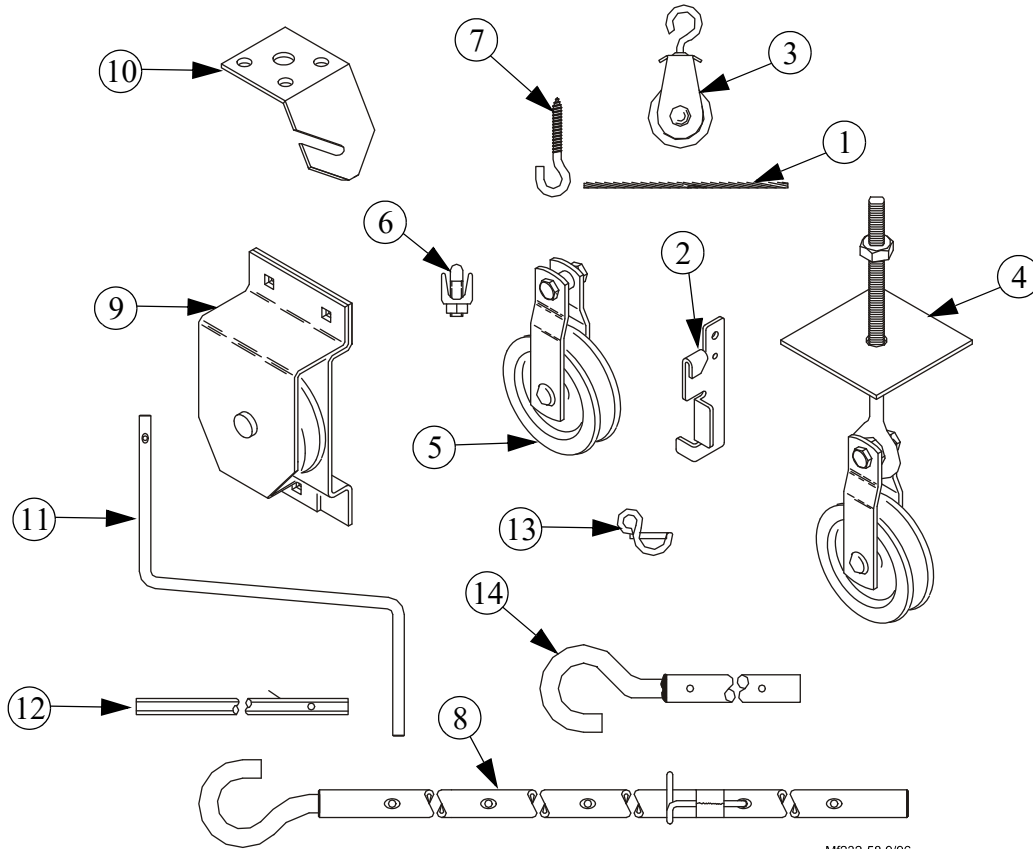

MF232-58 9/96

<u>Item</u>	<u>Description</u>	<u>Part No.</u>
1	3/16 Cable	1213
2	Cable Lock	14337
3	Pulley with Swivel	3004
4	Heavy Duty Pulley Assembly	2014
5	Pulley	2500
6	3/16" Cable Clamp	732
7	ATF Screw Hook	2041
8	Extendable drive tube	47637
9	Pulley Assembly	28429
10	Ceiling Hook	28550
11	Handle Shank	3148
12	Drill Adapter Shaft	2886
13	Winch Handle Pin	3761
14	Winch Drive Tube (4')	2884-1
	Winch Drive Tube (8')	2884-2
	Winch Drive Tube (2')	2884-4
--	Full Line Suspension Kit	7948

Item 11 and Item 13 may be ordered as a kit under Part No. 2885.

Item 12 and Item 13 may be ordered as a kit under Part No. 2886

Item 11, 13 and 8 may be ordered as a kit under Part No. 47638.

Item 10 and Item 12 may be ordered as a kit under part no. 2885.

This page left blank intentionally.....

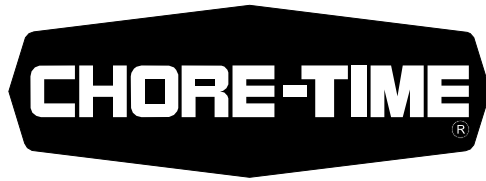

MADE TO WORK.

BUILT TO LAST.®

Revisions to this Manual

Page No.	Description of Change	ECO
	New Manual	36214

**For additional parts and information, contact your nearest Chore-Time distributor or representative.
Find your nearest distributor at: www.choretime.com/contacts**

CTB, Inc.
PO Box 2000
Milford, Indiana 46542-2000 USA
Phone (574) 658-4101 Fax (877) 730-8825
Email: choretime@choretime.com
Internet: www.choretime.com