

INSTALLATION INSTRUCTIONS SIDE BELT NEST LID OPENER SYSTEM



Note: The original, authoritative version of this manual is the English version produced by CTB, Inc. or any of its subsidiaries or divisions, (hereafter collectively referred to as "CTB"). Subsequent changes to any manual made by any third party have not been reviewed nor authenticated by CTB. Such changes may include, but are not limited to, translation into languages other than English, and additions to or deletions from the original content. CTB disclaims responsibility for any and all damages, injuries, warranty claims and/or any other claims associated with such changes, inasmuch as such changes result in content that is different from the authoritative CTB-published English version of the manual. For current product installation and operation information, please contact the customer service and/or technical service departments of the appropriate CTB subsidiary or division. Should you observe any questionable content in any manual, please notify CTB immediately in writing to: CTB Legal Department, P.O. Box 2000, Milford, IN 46542-2000 USA.

WARRANTY

Manufacturer warrants each new product manufactured by it to be free from defects in material or workmanship for one (1) year from and after the date of initial installation by or for the original purchaser. If such a defect is found by Manufacturer to exist within the one-year period, the Manufacturer will, at its option, (a) repair or replace such product free of charge, F.O.B. the factory of manufacture, or (b) refund to the original purchaser the original purchase price, in lieu of such repair or replacement. Labor costs associated with the replacement or repair of the product are not covered by the Manufacturer.

Conditions and Limitations

1. The product must be installed by and operated in accordance with the instructions published by the **Manufacturer or Warranty will be void.**
2. Warranty is void if **all components** of the system are not original equipment supplied by the Manufacturer.
3. This product must be purchased from and installed by an authorized distributor or installer or a certified representative thereof **or the Warranty will be void.**
4. Malfunctions or failure resulting from misuse, abuse, negligence, alteration, accident, or lack of proper maintenance, or from lightning strikes, electrical power surges or interruption of electricity, shall not be considered defects under the Warranty.
5. This Warranty applies only to systems for the care of poultry and livestock. Other applications in industry, commerce, or residential applications are not covered by this Warranty and are **strictly prohibited.** Any such use **will void the Warranty.**

Manufacturer shall not be liable for any **Consequential or Special Damage** which any purchaser may suffer or claim to suffer as a result of any defect in the product. "**Consequential**" or "**Special Damages**" *as used herein include, but are not limited to, lost or damaged products or goods, costs of transportation, lost sales, lost orders, lost income, increased overhead, labor and incidental costs and operational inefficiencies.*

THIS WARRANTY CONSTITUTES THE MANUFACTURER'S ENTIRE AND SOLE WARRANTY AND THIS MANUFACTURER EXPRESSLY DISCLAIMS ANY AND ALL OTHER WARRANTIES, INCLUDING, BUT NOT LIMITED TO, EXPRESS AND IMPLIED WARRANTIES AS TO MERCHANTABILITY, FITNESS FOR PARTICULAR PURPOSES SOLD AND DESCRIPTION OR QUALITY OF THE PRODUCT FURNISHED HEREUNDER.

Distributors are not authorized to modify or extend the terms and conditions of this Warranty in any manner or to offer or grant any other warranties for the products in addition to those terms expressly stated above. An officer of the Manufacturer must authorize any exceptions to this Warranty in writing. Manufacturer reserves the right to change models and specifications at any time without notice or obligation to improve previous models.

Effective 01/07

	13057	CLAMP, CORD PLASTIC 2 per kit
	11000034	CLAMP WIRE NYLON 2 per kit
	00101824	PULLEY NYLON 7/8" 2 per kit
	16-34096	RIVET: POP 3/16" AL 14 per kit
	16005182	NUT 3/8-16 NYLON LOCK 1 per kit
	16060011	SPACER, SCH 40 3/8 GALV x 2.36 2 per kit
	16-103329	SPRING, SB NEST LID CLOSER 6 per kit
	16060039	SCREW, HEX TAP 3/8-16 x 5.50 1 per kit

Parts Available From AGILE Mfg. Inc. For Complete System Installation:

A48028-2230	WINCH, 26" W/SWIVEL TOP (CHAIN) 30 RPM 1-60/50-230/220-240 <u>For Systems with 62 Nests or Less (Direct Pull Connection)</u>
A48028-4230	WINCH, 48" W/SWIVEL TOP (CHAIN) 30 RPM 1-60/50-230/220-240 <u>For Systems Over 63 Nests or More (Connect Through Turn-Back)</u>
46904	PKG, SPROCKET, CHAIN, & BRACKET
47958	SPRING, 160# 67" EXTENSION 1-5/8 x 28"
00101691	CABLE, 3/16" 7 x 7 WEAVE (Per Foot)
00101758	CABLE CLAMP 3/16"
10106151	PULLEY, NYLON 1-7/8"
05100177	CURTAIN CORD 1000'/ROLL (Ea.)

STEP 1 - PULLEY & SPACER ATTACHMENT

Assemble Spacers & Pulleys on Bolt through 3/8" diameter hole in nest back beside the center flipper support. Orient Pulleys as shown and tighten 3/8" Nylock Nut securely.

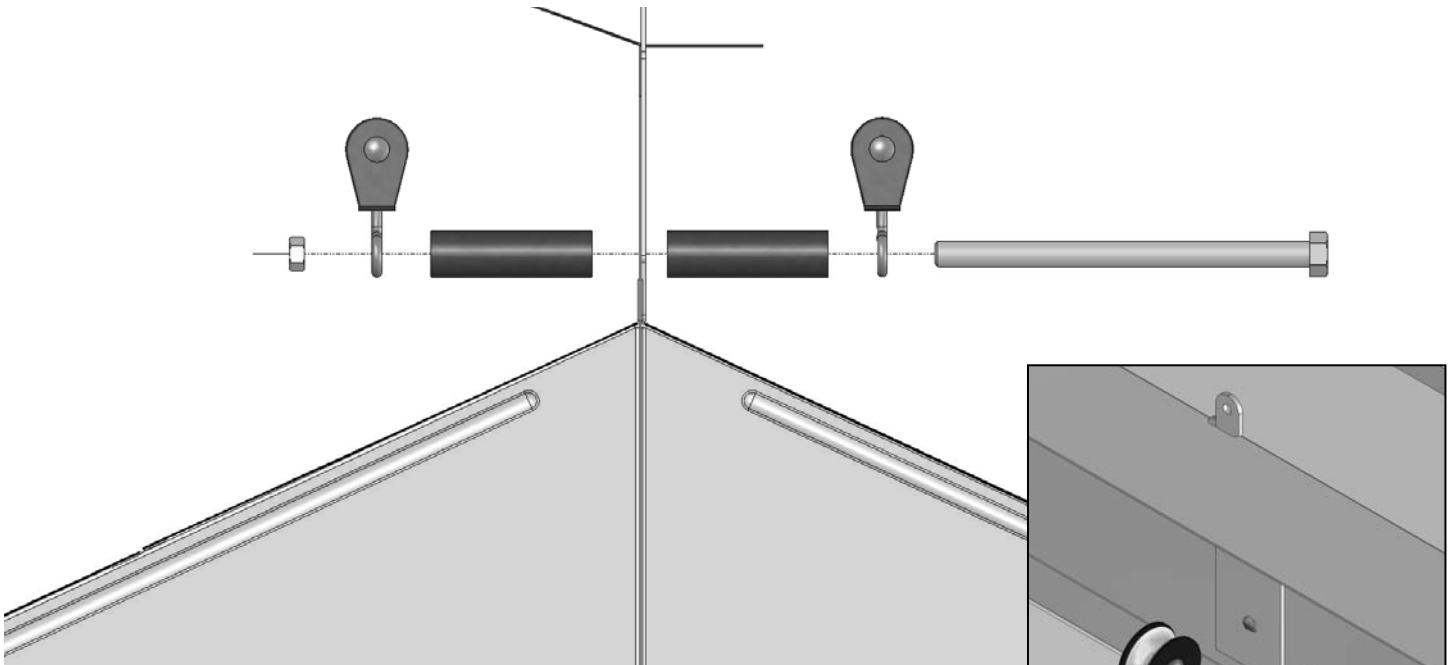

STEP 2 - LID SPRING ATTACHMENT

Attach three Lid Springs to each Hinged Lid and Nest Top with Pop-Rivets. For best results, orient Pop-Rivets through the Springs and outward through the Tops and/or Lids as shown. Each Lid requires three Springs.

NOTE : The Springs will require slight compression to align the rivet holes with the holes in the Tops & Lids.

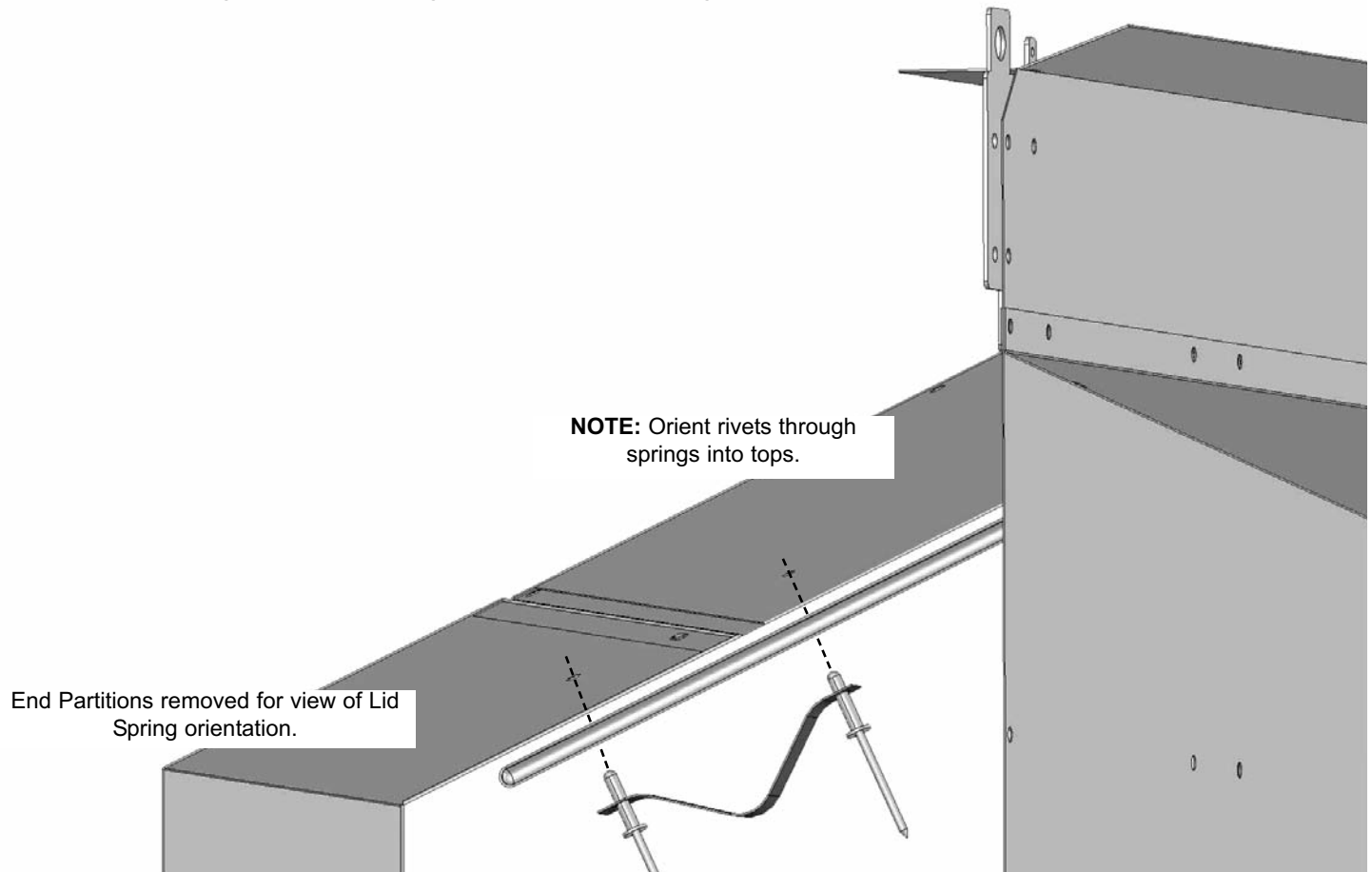

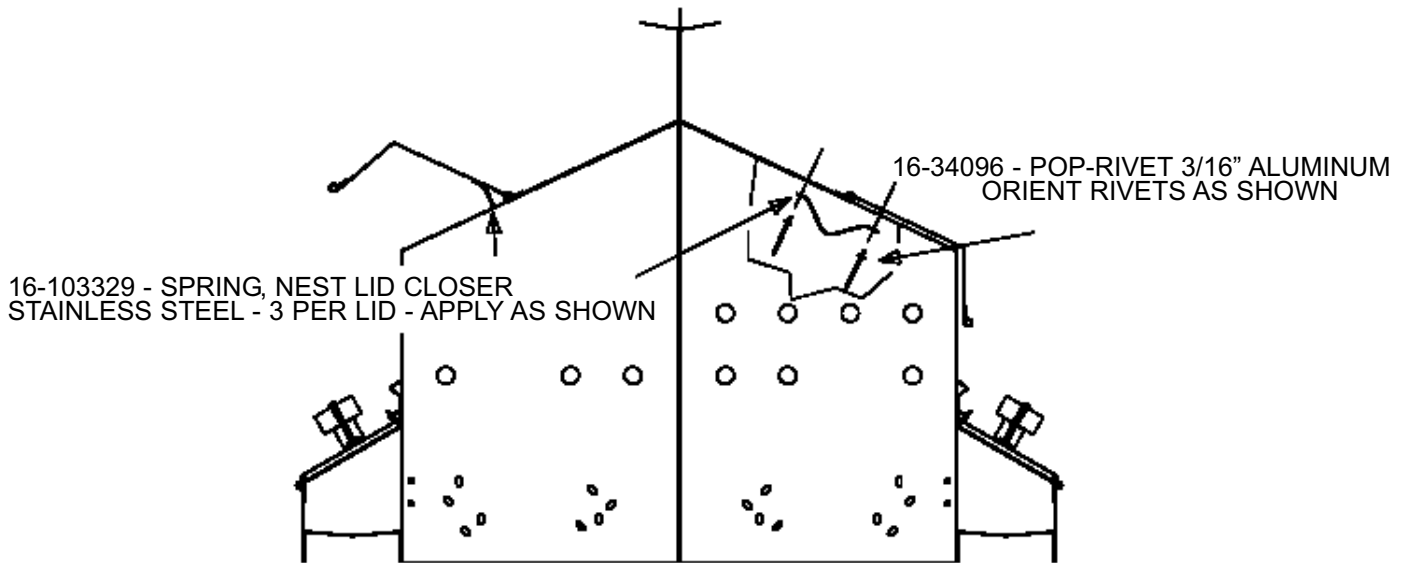

NEST LID SPRING ATTACHEMENT & POSITION

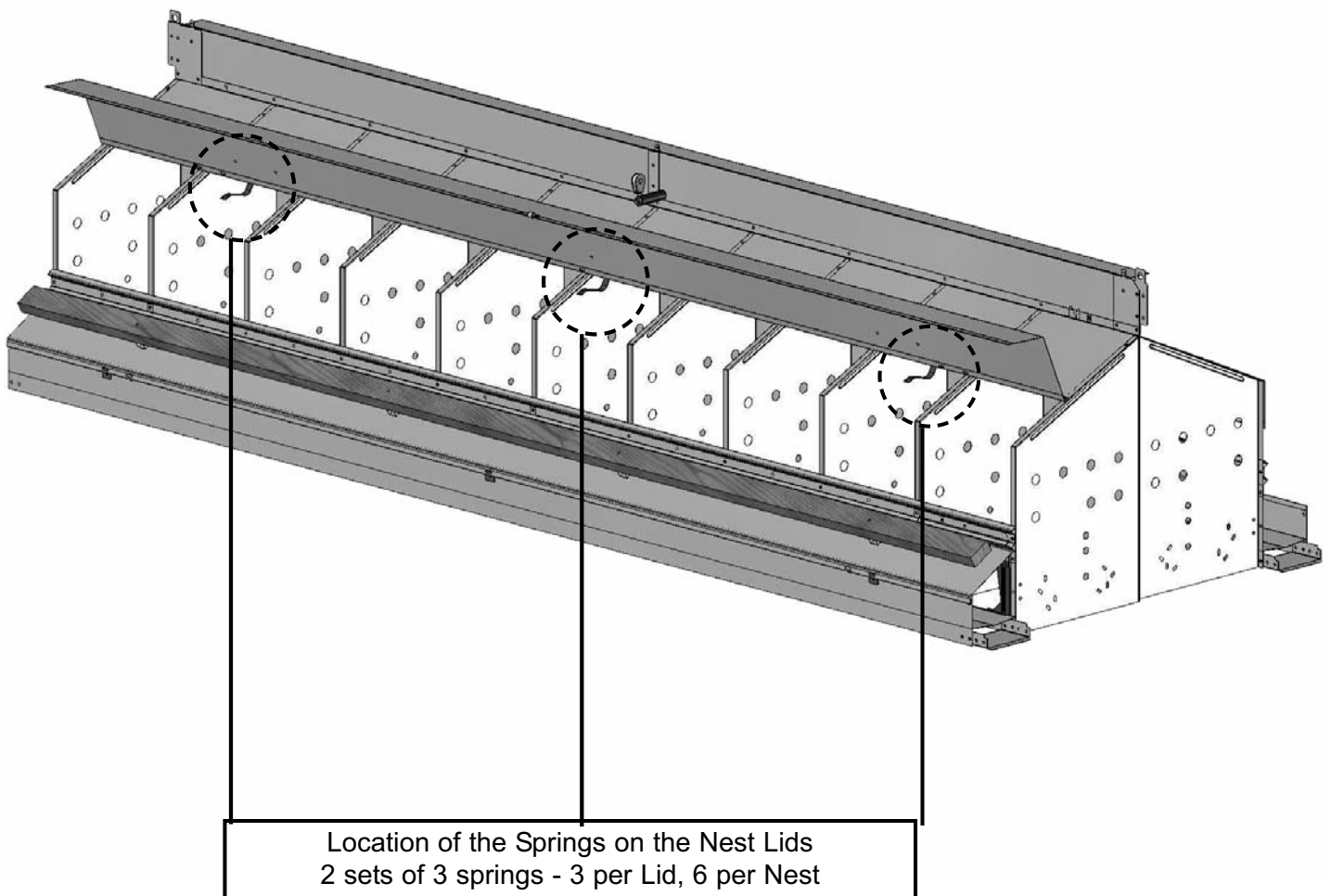

STEP 3 - CORD CLIPS ON LIDS

Attach one plastic Cord Clip to each Lid with a Pop-rivet oriented as shown. For best results, attach the clip to the lid at the hole that best aligns with the Pulley above it. See diagrams on the following pages.

Front side of Nest with Cord Clip and Pulleys attached.

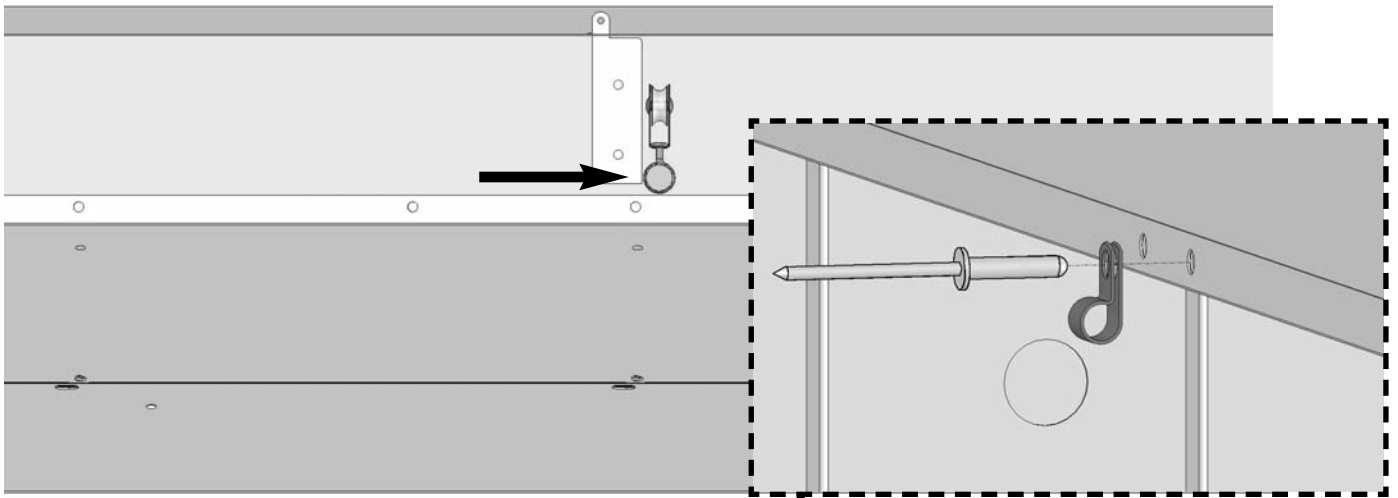

Attach clip in RIGHT hole on nest lid
(Also shown below.)

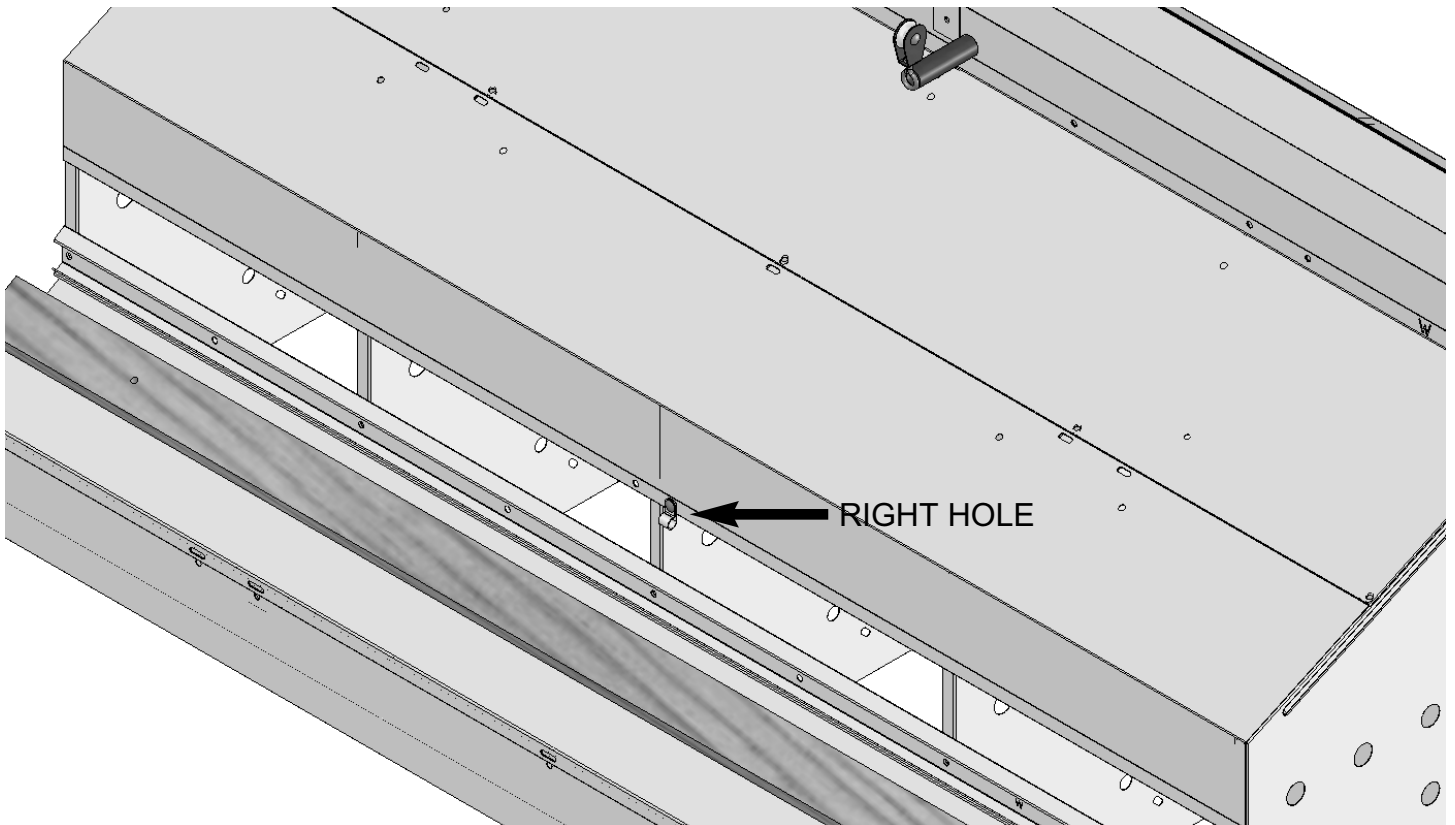
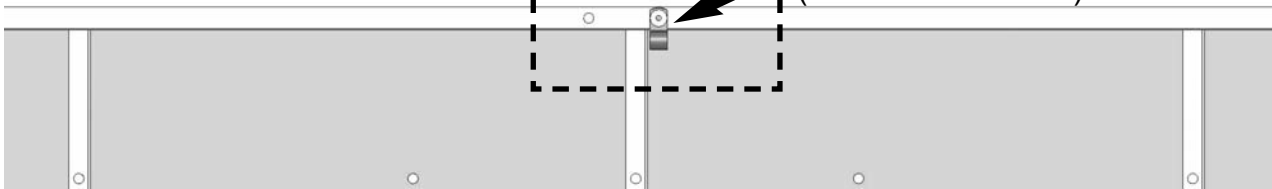

Opposite side of same Nest with Cord Clip and Pulleys attached.

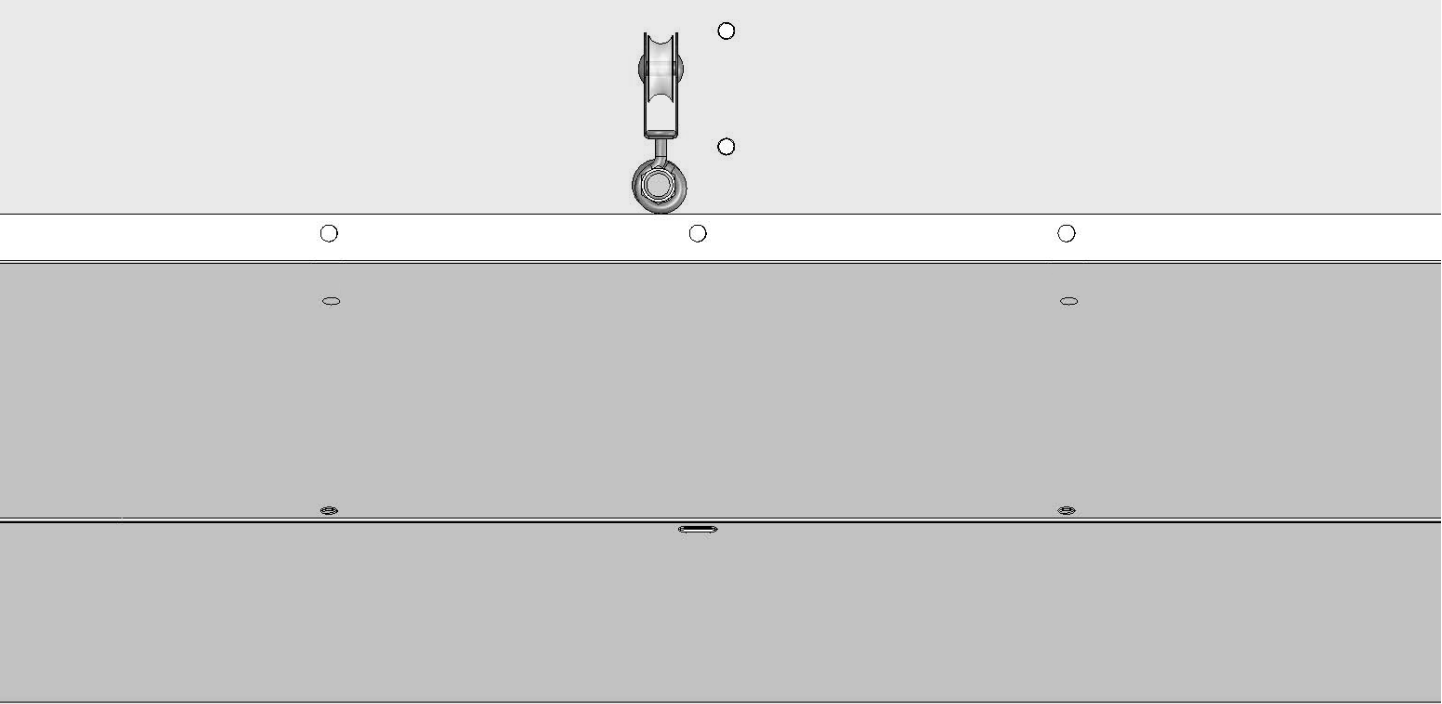

Attach clip in LEFT hole on nest lid. (Also show below)

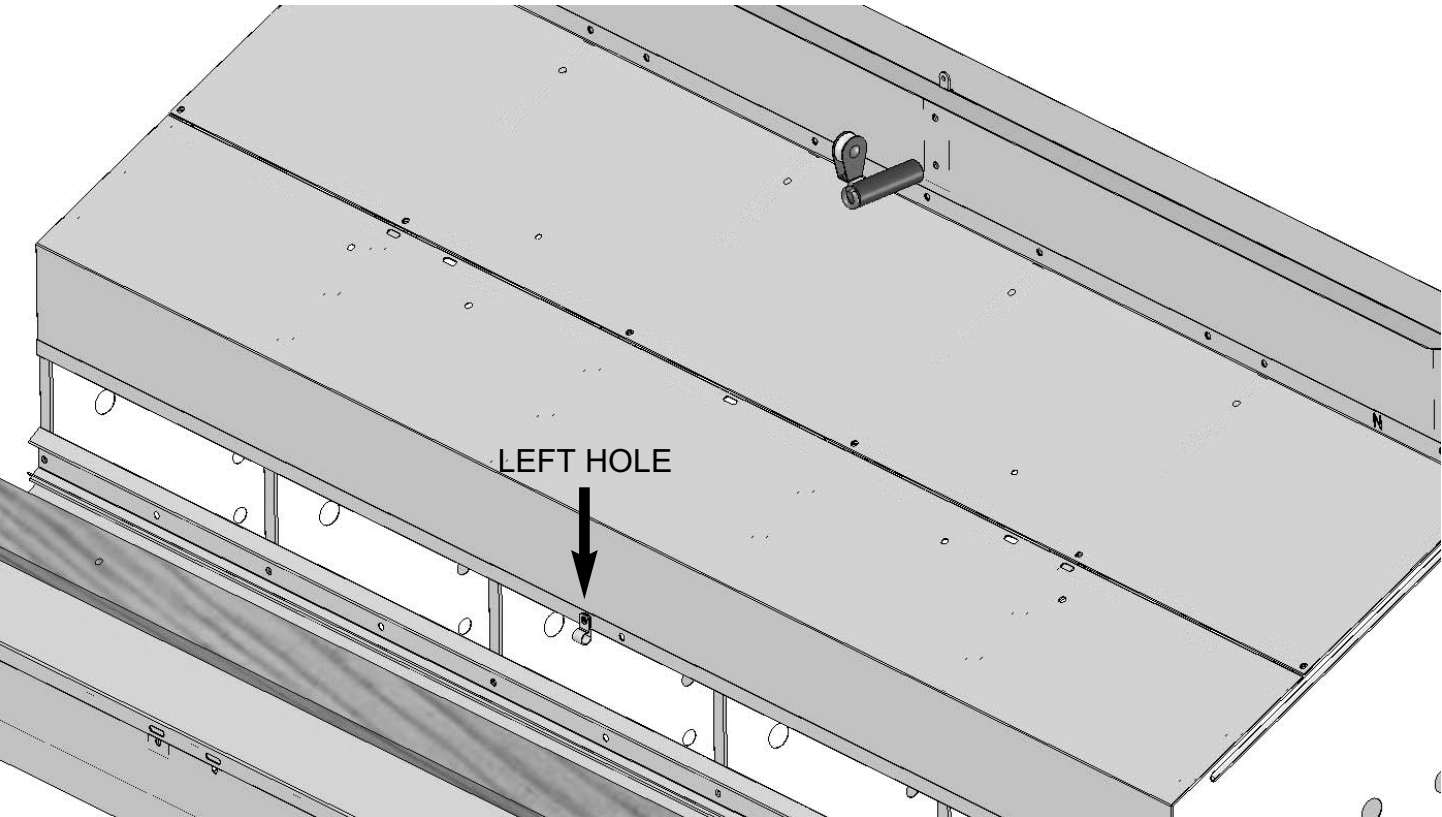

STEP 4 - NEST LID CORD ATTACH AND CABLE SYSTEM DETAIL

Use 1/8" Nylon cord (not supplied) to connect the Lids to the main cable to avoid fatigue & breakage from repeated open & close operation. The diagram shown below gives a perspective view of the cord and cable connections to the nest Lids and drive system. The main system cable should be offset from overhead-center of the nest line to avoid interference with the nest line suspension system. The pulleys, cable, mounting hooks, crimp-on clamps, and return springs shown are common suspension items and are NOT included in the Auto-Closer Kit. See the list of available parts from Agile Mfg., Inc. at the beginning of this document.

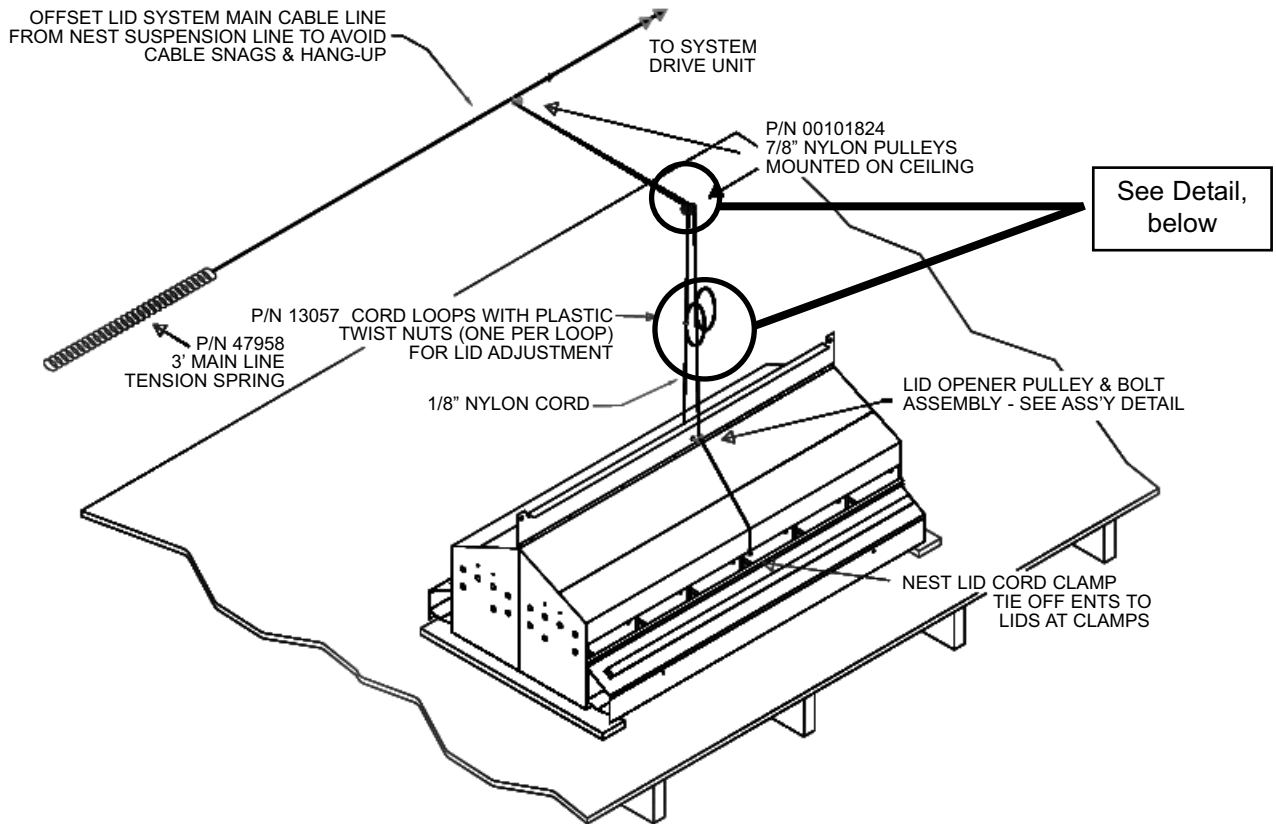

NEST LID CORD ATTACHMENT & ROUTING

View of double cord pulleys P/N 00101824 installed on ceiling.

Allow enough cord length to each lid to allow a loop for system individual lid adjustment at startup after each flock clean-out. Place a P/N 13057 cord clamp on each loop as shown.

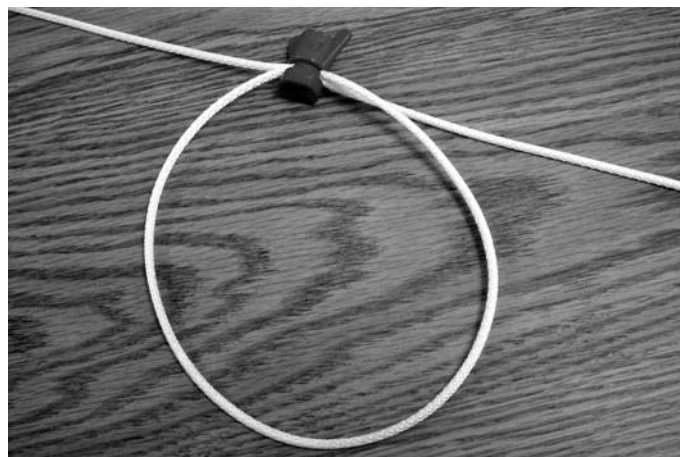

An extension spring is required at each main cable line end to provide back-tension on the main cable and avoid slack and maintain lid adjustment.

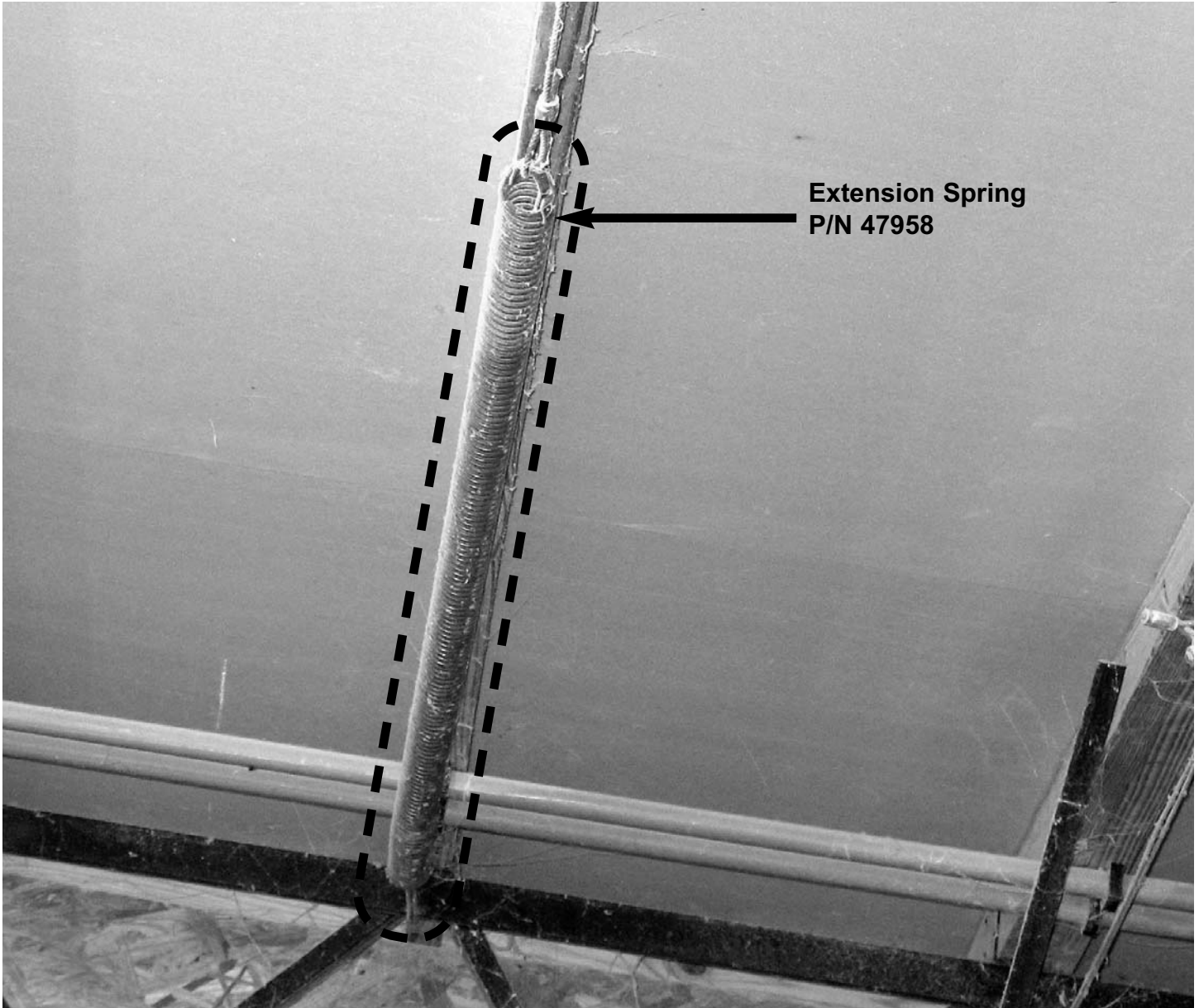

STEP 5 - SYSTEM LOAD AND POWER UNIT CONNECTION DETAIL

On nests with two sets of double springs installed on each lid, each nest will require a combined pull force of 25 lbs. (min. approx.) and a travel of 16" to fully open the lids. For reliable, long term operation of an automated lid system, Agile Mfg. Inc. specifies the following application limits for system layouts:

- For nest systems (houses) with **Up To And Including 62 Nests**, a chain drive linear-type power unit with a travel stroke of 22" or more can be used in a direct connection configuration (see below).
- For nest systems (houses) with **63 Nests And Over**, a chain drive linear-type power unit with a travel stroke of 44" or more must be used in a turn-back connection configuration (see below).

REQUIRED PULL FORCE : 25 LBS PER NEST (LID PAIRS)

REQUIRED SYSTEM TRAVEL : 16" (CLOSED TO FULL OPEN)

DRIVE SYSTEM REQUIREMENTS:

CONNECT NO MORE THAN 62 NESTS (1550 LBS.)
IN EITHER 1 OR 2 LINES OF NESTS TO SYSTEM
DRIVE UNIT IN DIRECT-PULL CONNECTION.

SYSTEMS CONNECTING OVER 62 NESTS REQUIRE A
TURN-BACK LINE CONNECTION AND A DRIVE UNIT
WITH A MINIMUM STROKE LENGTH OF 36". A UNIT
WITH 48" STROKE LENGTH IS PREFERRED FOR LINE
ADJUSTMENT ALLOWANCE.

DIRECT CONNECTION

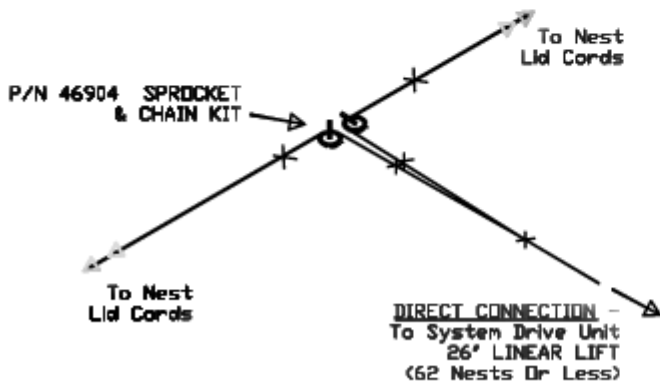

TURN-BACK CONNECTION

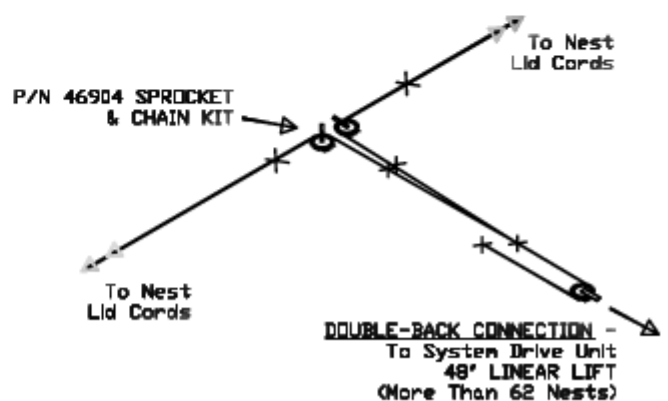

CONNECTION TO CHAIN DRIVE UNIT

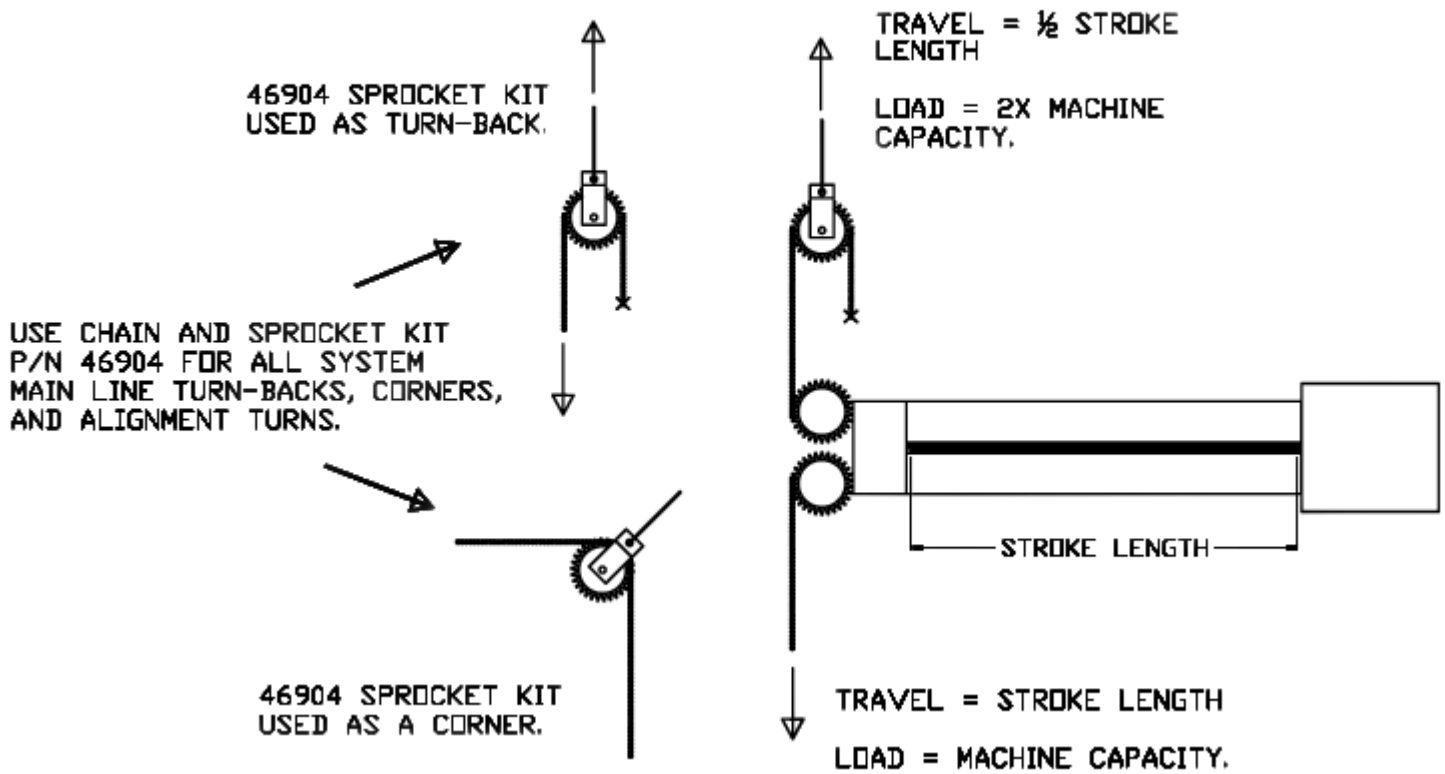

A chain and sprocket kit, such as P/N 46904 (see below), is required on all system drive line corners and turn-backs to prevent fatigue and breakage from repeated operation. Refer to the diagram below to plan the system installation.

Pro-Terra Linear Lift w/chain



