

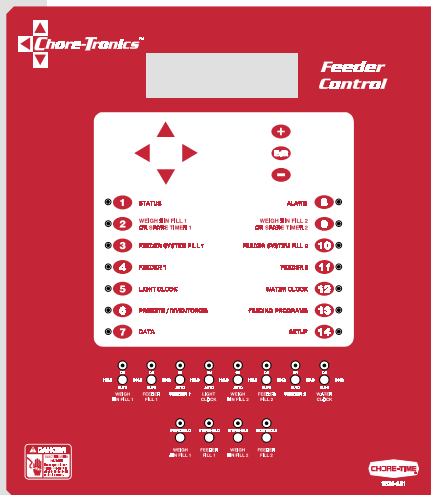

Feeder Control



MT1559-01 7/98

User / Installer Manual

MT1559A
March 1999

Chore-Time Warranty

Chore-Time Equipment warrants each new product manufactured by it to be free from defects in material or workmanship for one year from the date of initial installation by the original purchaser. If such a defect is found by Chore-Time to exist within the one year period, Chore-Time will, at its option, (a) repair or replace such product free of charge, F.O.B. the factory of manufacture, or (b) refund to the original purchaser the original purchase price, in lieu of such repair or replacement.

Conditions and limitations:

1. The product must be installed and operated in accordance with instructions published by **Chore-Time or warranty will be void.**
2. Warranty is void if **all components** of a system are not supplied by **Chore-Time.**
3. This product must be purchased from and installed by an authorized Chore-Time dealer or certified representative thereof, or the warranty will be void.
4. Malfunctions or failure relating to or resulting from misuse, abuse, negligence, alteration, accident, or lack of proper maintenance, or from lightning strikes, electrical power surges or interruption of electricity, shall not be considered defects under this warranty.
5. This warranty applies only to systems for the care of poultry and livestock. Other applications in industry or commerce are not covered by this warranty.

Chore-Time shall not be liable for any **Consequential or Special Damage** which any purchaser may suffer or claim to have suffered as a result of any defect in the product. **“Consequential” or “Special Damages”** *as used herein include, but are not limited to, lost or damaged products or goods, costs of transportation, lost sales, lost orders, lost income, increased overhead, labor and incidental costs and operational inefficiencies.*

THIS WARRANTY CONSTITUTES CHORE-TIME'S ENTIRE AND SOLE WARRANTY AND CHORE-TIME EXPRESSLY DISCLAIMS ANY AND ALL OTHER WARRANTIES, INCLUDING, BUT NOT LIMITED TO, EXPRESS AND IMPLIED WARRANTIES AS TO MERCHANTABILITY, FITNESS FOR PARTICULAR PURPOSE SOLD AND DESCRIPTION OR QUALITY OF THE PRODUCT FURNISHED HEREUNDER.

Any exceptions to this warranty must be authorized in writing by an officer of the company. Chore-Time reserves the right to change models and specifications at any time without notice or obligation to improve previous models.

CHORE-TIME EQUIPMENT, A Division of CTB, Inc.
P.O. Box 2000
Milford, Indiana 46542-2000 U.S.A.

Contents

Topic	Page
Chore-Time Warranty	2
General	5
Support Information	5
Distributor and Installer Information	5
Introduction	6
Explanation of Symbols and Special Manual Elements	6
Safety Instructions and Warnings	7
Notice to Electrician	8
Initial Setup	9
Introduction to Control	10
Description of Control Front Panel	10
Viewing Screen	11
Navigation Buttons	11
Edit Buttons	11
Subject Buttons	12
Indication Lights and Auto/Manual Switches	12
Manual Start/Hold switches	12
How to Maneuver in the Viewing Screen	13
Using the Navigation Buttons	13
Using the Edit Buttons	14
Operation and Description of Function Settings	16
Status	16
Weigh Bin Fill 1	17
Spare Timer 1	17
Feeder System Fill 1	18
Feeder 1	19
Light Clock	20
Presets / Inventories	21
Option 1: Separate Weigh Bin	21
Option 2: Load Cells Under Supply Bin	22
Data	23
Alarms	25
Possible alarms discussed:	26
Weigh Bin Fill 2 or Spare Timer 2	27
Feeder System Fill 2	27
Feeder 2	27
Water Clock	27
Feeding Programs	28
Sample of Feeding Programs	28
Setup	29
Actual House Layout	32
Weigh Bin Configurations	33
MS Board Dip Switch Positions	39
Scale Junction Box Add-On's	40
SJB - SJB1 (Scale Junction Boxes)	40
Technical Specifications	41
PC Connection Overview	42
Off-Site PC Connecting to On-Site PC with Controls	42
On-Site PC with Controls	43
Off-Site PC with Controls	44

Contents - continued

Topic	Page
Trouble Shooting	45
Parts Listing	46
Installation and Operation of Scale Load Cells	47
System Planning	47
Site Planning	50
Bin Pad Locations and Dimensions	50
7' Storage Bin & Weigh Bin using (2) Pads	50
9' Storage Bin & Weigh Bin using (2) pads	51
7' Storage Bin & Weigh Bin using (1) pad	51
9' Storage Bin & Weigh Bin using (1) pad	52
Bin Platform Specifications	52
Bin Platform for:	53
(2) 7 Foot, 4 Legged Bins	53
12 Foot, 8 Legged Bins	54
(2) 7 Foot, 4 Legged Bins	55
(2) 9 Foot, 6 Legged Bins	56
(2) 9 Foot, 6 Legged Bins	57
(2) 12 Foot, 8 Legged Bins	58
Load Cell Mount Height	59
T.C 15 Mount	59
T.C. 125 and T.C. 35 Mount	59
T.C. 180 Mount	60
C.T 30 Mount	60
Installation of the Scale Components	61
Step 1: Mount Base Location	61
Step 2: Mount Base Assembly and Installation (for T.C. Load Cells)	61
Step 2: Mount Base Assembly and Installation (for C.T. Load Cells)	62
Step 3: SJB Location & Installation	64
Grounding for the SJB and the Feeder Control	65
Step 4: Properly Coiling the Cables	66
Step 5: Grounding the System	66
Load Cells and Mount Kits	70
T.C. 35 & 125	70
T.C. 15	70
T.C. 180	70
C.T. 30K	71
Scale Systems available (by weight):	71
Inspect Junction Box Wiring	72
Test the Junction Box	72
Test the Load Cells	72
Replacing a CT Load Cell	73
Wiring Diagrams	75
Wiring Diagram #1	75
Wiring Diagram #2	76
Wiring Diagram #3	77
Wiring Diagram #4	78
Wiring Diagram #5	79
Wiring Diagram #6	80
Wiring Diagram #7	81
Wiring Diagram #8	82
Wiring Diagram #9	83

General

Support Information

Using this equipment for any other purpose or in a way not within the operating recommendations specified in this manual will void the warranty and may cause personal injury.

*** {Note}** — **As with all electronic controls, we recommend the use of a backup system. This will provide continuous operation in the unlikely event of a control failure.**

Distributor and Installer Information

Please fill in the following information about your Product.
Keep this manual in a clean, dry place for future reference.

Distributor's Name _____

Distributor's Address _____

Distributor's Phone _____ **Date of Purchase** _____

Installer's Name _____

Installer's Address _____

Installer's Phone _____ **Date of Installation** _____

System Specifications _____

Introduction

This manual is designed to provide comprehensive planning, installation, operation, and parts listing information. The Table of Contents provides a convenient overview of the information in this manual.

Read this manual before operating your Control.

If you have any questions regarding your Control, please contact your local Chore-Time dealer.

Explanation of Symbols and Special Manual Elements



<Caution>

Cautions alert you to potential damage to the Controller, if the procedures are not followed carefully.



! Danger !

Dangers alert you to potentially hazardous situations which, if not avoided could result in death or personal injury.

*** {Note}**

Notes contain additional information or "reminders" of important information you should know.

Safety Instructions and Warnings

- Read all instructions in this manual carefully, before operating the Control.
- Ground all electrical equipment for safety.
- The installation of the Control must be done by an authorized technician / installer
- All wiring should be done by a qualified electrician in accordance with local and national electrical codes.
- Electrical current to control must be hard wired into breaker box, eliminating any receptacle.
- Control should be located in an area that is protected from the elements.
- Front cover must be kept closed at all times except when front panel is in use.
- Control should be mounted securely to an internal wall or to a board that is mounted to a wall.
- It is recommended that access codes be used to avoid unintentional alterations to the settings.
- It is recommended that an audible warning device (i.e. siren, phone dialer, etc.) be used to inform grower of unacceptable conditions.
- Check the Control regularly for possible malfunctioning. Notify your local Chore-Time distributor of any problems.
- It is recommended that the control be energized year round. This will help the interior of the control to stay dry, and extend the life of the memory backup battery. If the house is empty, use the manual switches to discontinue the function of equipment wired to the control.



<Caution>

- Check your Control regularly for proper functioning. This control is manufactured to provide reliable operation as well as an alert system to notify you of system failures. However, this cannot be 100% guaranteed because of circumstances that are beyond Chore-Time's control.
- Chore-Time takes no responsibility for any possible damage as a result of improper settings and non or partially functioning installation.
- Chore-Time takes no responsibility for any possible damage due to failure, damage, or malfunction resulting from misuse, abuse, negligence, alteration, accident, lack of proper maintenance, improper or insufficient power sources or electrical connections, impact of foreign objects, tornado, hurricane, other violent storm, flood, fire, pollutants, chemicals, acts of God, or other causes outside the reasonable control of Chore-Time.



! Danger !

- Do not use running water or high pressure washers on or around your control.

Notice to Electrician

Each relay output in this Chore-Tronics™ control is designed to control 1 H.P. for many years of service. The relays are single pole, normally open contacts and break only one line of the power to the various loads. (The control is not to be considered the disconnect device for motor loads.) If a load of more than 1 H.P. is controlled by a relay in the control, additional contactors are required and some of the basic flexibility of the control is compromised. It is very important that the owner/integrator understands that the grouping of loads compromises flexibility.

It is recommended that the installation diagram on **page 32** be used to configure the house, and the relay decal inside the box is filled out completely. If this step is completed prior to wiring, it will eliminate any unnecessary confusion. Filling out the relay position decal will help to properly group the loads.

Initial Setup

1. Referring to the drawing on **page 32** (as was mentioned in the previous section), attach the small decals that are included with the control to the numbered toggle switches on the face of the control. The names of the devices have to be associated with the switch numbers which in turn correspond to the relay numbers. This step cannot be avoided. The control requires that the relay numbers be associated with names.
2. Answer all questions and adjust all settings in *Screen #14*. In this screen the relay numbers are associated with the output names in the drawing on **page 32**. This must be done first in that the other screen's contents are affected by the answers and settings of *Screen #14*.
3. Answer all questions, and adjust settings in Screens # 2, 3, 4, 5, 6, 8, 9, 10, 11, 12, and 13.
4. Recheck all screens to verify everything is as desired.



! Danger !

While going through the setup steps, place manual switches in "Off" position until the process is completed.

*** {Note}**

Ignore alarms until setup process is completed. Then reset alarm system as described in Alarms section of this manual.

Introduction to Control

Description of Control Front Panel

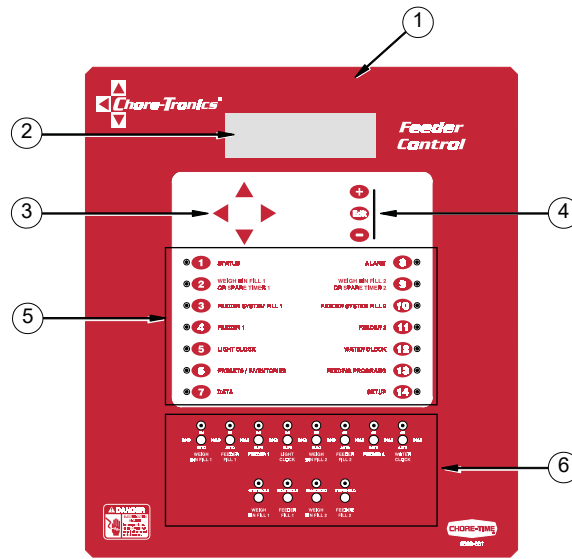

MT1559-02 7/98

Item	Description
1	Feeder Control
2	Viewing Screen
3	Navigation Buttons
4	Edit Buttons
5	Subject Buttons
6	Relay Switches

Viewing Screen

The viewing screen has a display which can show 8 lines, each containing 40 characters. This is the area that will display the requested information when a subject button is pressed. The viewing screen will always remain lit. When other subjects are not shown, the *Status* screen will be displayed

Today = Feed Day		Program = Daily
Next Start Time	#1	#2
Weigh Fill	Thu 4:00p	Thu 5:00p
Feeder Fill	Thu 6:00p	Thu 6:00p
Feeder Line	Fri 5:00a	Fri 5:00a
Light/Water	Thu 5:00a	Thu 5:00a
(Check Switches)		(Check Alarms)
Date = Thu 19 Aug 1998		Time = 1:05p

Navigation Buttons

These buttons allow you to scroll up and down in those few screens that have more information than will fit on the screen. When **HOLDING DOWN** an *up* or *down* arrow button, this will activate "auto repeat", which accelerates the scrolling process. The *left* and *right* arrows are used only when you are in the *Edit Mode* (explained below) and will move a cursor to an editable (changeable) position. This will highlight the area you want to change.

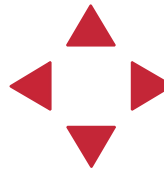

Edit Buttons

When the button labeled **EDIT** is pressed and you are looking at a screen that has editable fields, a cursor will appear. With the *Navigation Buttons*, you can move the cursor to the position on the screen you want to edit. By pressing the "+" or "-" button, it will change the numerical value up or down, or if you are changing text (i.e. "yes" or "no") it will select the possible text choices. These buttons also have "auto repeat" which will accelerate the changing of numbers.



To provide for security in setting your controls, there is an optional security feature that will appear only when you initiate the *Edit* process. When you press the **EDIT** button, the control will automatically ask for an access code. This is a four digit number that you have selected while setting up the control and is explained under the “**Setup**” section. Once you have inserted the correct code, the control will allow you to make all the edits you need. However, if five minutes have passed since your last edit, and you would like to make further edits, you will have to reinsert your access code. As long as you are working with the settings and the five minutes have not elapsed, you can make as many edits as you need without reinserting the code.

* **{Note}**

**An example of using the *Edit Buttons* and the *Navigation Buttons* are discussed later in this section.
See “How to Maneuver in the Viewing Screen”**

Subject Buttons

On the front of the Controller are 14 subject keys each with an indicator light.

As each subject button is pressed, the subject that is described beside the button will appear on the screen and the light on the other side of the button will be lit. After viewing that subject for five minutes, and if no other buttons are pressed, the control will automatically return to *Status*.

An explanation of each subject is described in the following section entitled “**Operation**”.

Indication Lights and Auto/Manual Switches

Each relay output has its own three position switch that allows the user to manually control the relay. Each switch is labeled showing what function it controls and can be placed in three positions — “ON”, “HOLD”, or “AUTO”. The “AUTO” position is for normal operation and allows the control to perform all the functions. Changing the switches to “ON” or “HOLD” will either enable or disable (an enabled relay allows current to flow to the equipment wired to it) that particular relay. When a switch is in a position other than “AUTO”, a message will appear in the *Status* screen advising to “check switches”. The software provided for off-sight monitoring will also inform the user of the switch positions. **This does not apply to unused relays.**

The light above the switch indicates that the relay is activated. This light will stay off if the switch is in the “HOLD” position.

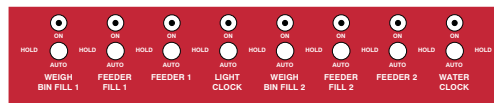

MT1559-03 7/98

Manual Start/Hold switches

These spring loaded switches allow you to start the operation assigned to them prior to the times set in above screens. They can only be used in the proper sequence.

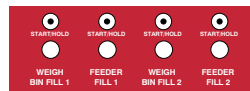

MT1559-04 7/98

How to Maneuver in the Viewing Screen

- The procedures below give a brief overview on the use of the *Navigation Buttons* and the *Edit Buttons*.
- For this example we will be looking at the *Setup* Screen. (*Button 14* on the Control front panel).

Using the Navigation Buttons

1. Press **BUTTON 14**.
Setup screen for viewing appears (**Figure 1**).

Control number	1
Units of measurement	NON-METRIC
Clock Type	12 HR
Time of day	8:25a
Date	22 Jul 1998

Figure 1. Setup Screen.

At this point you can move from line to line by pushing the **DOWN ARROW** or the **UP ARROW**. This will cause the text to either scroll up or down one line at a time.

2. Press the **DOWN ARROW** once.
The text will scroll one line (**Figure 2**). If you push the **UP ARROW** once the text will scroll back to the previous line.

Units of measurement	NON-METRIC
Clock Type	12 HR
Time of day	8:25a
Date	22 Jul 1998
CONFIGURATION:	

Figure 2. Setup Screen.

* {Note}

The **LEFT** and **RIGHT** arrow keys are only functional in the *Edit Mode*. See following page on the use of the *Edit Buttons*.

Using the Edit Buttons

- This example gives you a brief summary on how to use the *Edit Buttons* in conjunction with the *Navigation Buttons* to edit values.
- For this example we will be looking at the *Setup* Screen. (*BUTTON 14* on the Control front panel).

1. Press **BUTTON 14**.
Setup and Calibration screen for viewing appears (**Figure 3**).

Control number	1
Units of measurement	NON-METRIC
Clock Type	12 HR
Time of day	8:25a
Date	22 Jul 1998

Figure 3. Setup default Screen.

2. Press the **EDIT** button.

* **{Note}**

(If a screen comes up asking you for an "Access Code", enter it at this time. If more information is needed please turn to the operation section page 31.)

This activates the cursor and allows you to edit certain settings. Figure 4 shows what the screen looks like.

- Notice that the settings are highlighted when they can be edited.

The white text with black background designates those areas that can be edited to the individual growers specifications. When viewing the actual Control Display, the text will be black with a shaded green background.

Control number	1
Units of measurement	NON-METRIC
Clock Type	12 HR
Time of day	8:25a
Date	22 Jul 1998

Figure 4. Setup edit Screen.

3. Press the (+) or (-) buttons to edit the Control #.
The (+) key will increase the value and the (-) key will decrease the value.

4. Press the **DOWN ARROW** (Figure 5).

Control number	1
Units of measurement	NON-METRIC
Clock Type	12 HR
Time of day	8:25a
Date	22 Jul 1998

Figure 5. Setup edit Screen.

5. Press the (+) or (-) buttons to change from metric to non-metric. In this case the (+) and (-) buttons select different text choices.
6. If two or more editable settings are on the same line, the *left* and *right* arrow buttons will be used to move between those positions.

*** {Note}**

To exit the *Edit Mode* — Press the EDIT key. This will take you out of the edit mode and turn off the cursor.

When a value or text is edited, it is immediately saved in the control. This eliminates the need for an enter key.

Operation and Description of Function Settings

1

Status

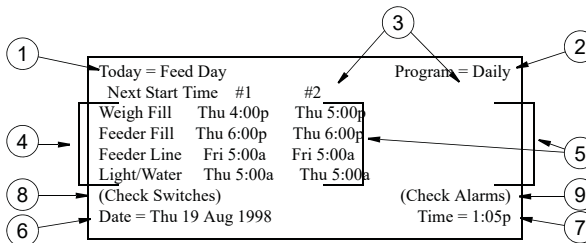

Figure 6. Status Screen

1. **Today** - this indicates if the current day is a feed or a non feed day—this is the only field that is editable in this screen.
2. **Program** - this indicates which program is currently being used (i.e. every-other-day, daily, 5-2 and 4-3).
3. There are two separate, independent feeding systems.
4. List of timed outputs being used.
5. Next start times for the timed output.
6. **Date** - shows the current date and the day of the week.
7. **Time** - shows the current time.
8. **Check switches** - this will show if one of the manual switches is in the “on” or “off” position. This does not apply to unassigned outputs.
9. **Check alarms** -if you have an alarm condition, this will show in this screen and remain until the condition is corrected or the alarm is turned off.

2

Weigh Bin Fill 1

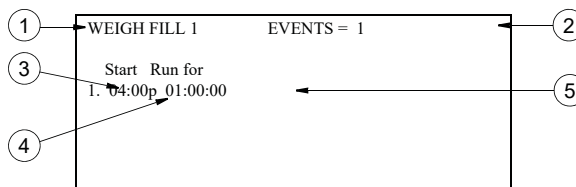

Figure 7. Weigh Bin Fill 1 screen

or...

Spare Timer 1

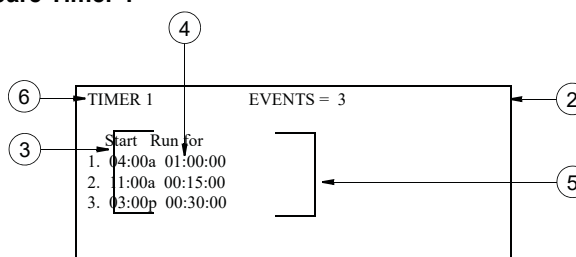

Figure 8. Spare Timer 1 screen

1. **Weigh Fill 1** - output used to activate weigh fill system — this choice is made in *Setup* screen *BUTTON 14*.
2. **Events** - the events are editable up to 24 events. Only those number of events selected will show in the screen below.
3. Editable fields to insert start time. All zeros in either column will eliminate event.
4. If a twelve hour clock is selected, an “a” or “p” must be selected.
5. **Run for** - this indicates the length of time you want this function to run.
6. **Timer 1** - this indicates that spare timer 1 has been chosen in the *Setup* screen *BUTTON 14*.

3

Feeder System Fill 1

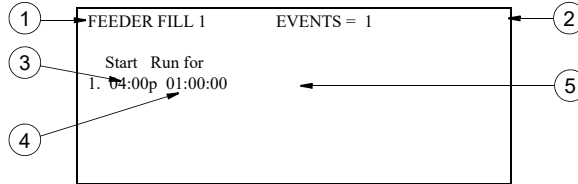

Figure 9. Feeder System Fill 1 screen

1. **Feeder System Fill 1** - this indicates that you are in the Feeder System Fill 1 screen.
2. **Events** - the events are editable up to 24 events. Only those number of events will show below.
3. Editable fields to insert start time. All zeros in either column will eliminate event.
4. If a twelve hour clock is selected, an "a" or "p" must be selected.
5. **Run for** - this indicates the length of time you want this function to run.

4

Feeder 1

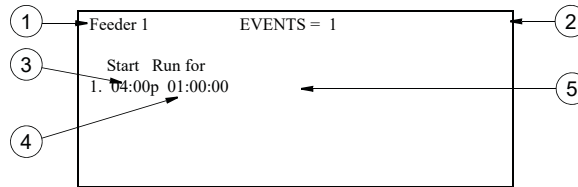

Figure 10. Feeder 1 screen

1. **Feeder 1** - this indicates that you are in the Feeder 1 screen.
2. **Events** - this indicates the number of feeding events that have been chosen—maximum of 24 events.
3. Editable fields to insert start time. All zeros in either column will eliminate event.
4. If a twelve hour clock is selected, an “a” or “p” must be selected. The type of clock is chosen in the *Setup* screen *Button 14*.
5. **Run for** - this indicates the length of time you want the feeder to run. The control allows for run times in seconds to provide for “stimulation cycles”.

5

Light Clock

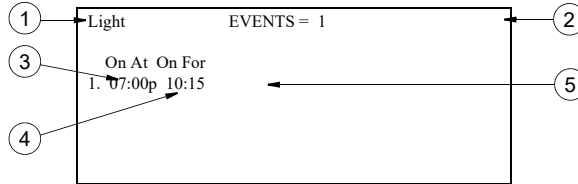

Figure 11. Light Clock screen

1. **Light Clock** - this indicates that you are in the Light Clock screen.
2. **Events** - this indicates the number of lighting events that have been chosen—maximum of 24 events.
3. Editable fields to insert “ON” time. All zeros in either column will eliminate event.
4. If a twelve hour clock is selected, an “a” or “p” must be selected. The type of clock is chosen in the *Setup* screen *Button 14*.
5. **On for** - this indicates the length of time you want the lights on.

6

Presets / Inventories

• This screen has two options and are briefly discussed below. The proper option will be selected in the *Setup* screen *Button 14*.

1. If your weigh system uses a separate bin from the supply bin to weigh the feed for feeding.
2. If your supply bin is equipped with load cells to perform the weighing and feeding function.

* {Note}

If you are using Option 2 above, it is recommended that you use the SJB1, which has a built-in interrupt switch. This will stop the feeder fill system if feed is being delivered. To restart the fill system, the button is pressed again at the end of the delivery. If the feeder fill system is not restarted within 60 minutes by pressing the button, it will restart automatically.

Option 1: Separate Weigh Bin

	#1	#2
Contents Supply Bin	34125	12452
Contents Weigh Bin	1200	740
Preset	1400	800
Feed delivered	0	0
Agreed?	NO	NO
Last delivery	20000	18400

Figure 12. Option 1 Separate Weigh Bin Screen

1. These represent the two separate weighing systems this control can handle.
2. **Supply Bin** - this is the current inventory of the supply bin which is a calculation only derived by adding delivery amounts and subtracting amounts that are transferred to the weigh bin (non-editable).
3. **Weigh Bin** - This is the current quantity of feed in the weigh bin. This is a true measurement produced by the load cells (non-editable).
4. **Preset** - this is the amount you want to feed at the next feeding time. This quantity is manually entered. If this is not changed, the control will continue to use the existing value.
5. **Feed Delivered** - this is where you manually enter the amount of feed delivered which is taken from a delivery ticket, weigh ticket, etc. This figure added to the above supply bin inventory (#2), gives you the current inventory weight.
6. **Agreed** - after entering the feed delivered you confirm this number by pressing the "+" button. This will temporarily place a "YES" in this column.
7. **Last Delivery** - this indicates the amount of the last delivery (non-editable)

Presets / Inventories - continued

Option 2: Load Cells Under Supply Bin

	#1	#2
Contents Supply Bin	34125	12452
Contents Weigh Bin	34125	12452
Preset	1400	800
Last delivery	15327	18409

Figure 13. Option 2 Load Cells Under Supply Bin Screen

1. These represent the two separate weighing systems this control can handle.
2. **Contents Supply Bin\Contents Weigh Bin** - this is the actual current inventory weight in the supply bin. This figure is provided by the load cells mounted under this bin (non-editable).
3. **Preset** - this is the amount you want to feed at the next feeding time. This quantity is manually entered. If this is not changed, the control will continue to use the existing value.
4. **Last Delivery** - this indicates the amount of the last delivery and is generated by the load cells (non-editable)

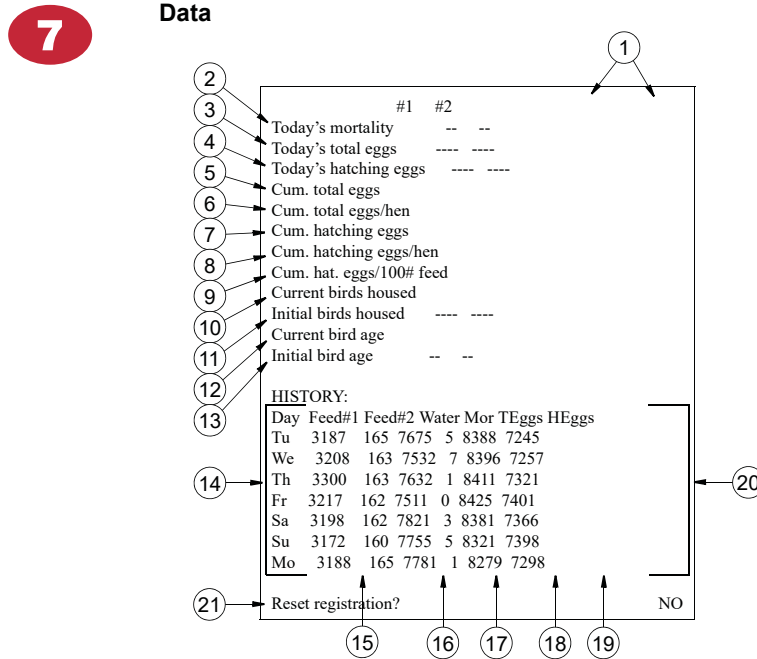

Figure 14. Data default Screen

*** {Note}** This screen which requires some manual input, will provide you with current and past information regarding your operation. The dashed lines represented above are the areas that must be entered manually

1. Data can be compiled for two different groups of birds, such as hens and roosters. Obviously in this case not all the information is pertinent for both (like egg counts), but birds housed certainly can be calculated.
2. **Today's mortality** - this is where you enter the current mortality.
3. **Today's total eggs** - if you are keeping track of total eggs, enter them here.
4. **Today's hatching eggs** - the current day's hatching eggs are entered here. The control will take the initial data entered below, then add, subtract, and divide the daily entered data and then calculate items 5-10.
5. **Cumulative total eggs for the life of the flock.**
6. **Cumulative total eggs per hen housed.**
7. **Cumulative hatching eggs.**
8. **Cumulative hatching eggs per hen**

Data - continued

9. **Cumulative hatching eggs per 100 pounds of feed.**
10. **Current birds housed** (males and females)
11. **Initial birds housed** - this is where you enter the initial birds housed
12. **Current birds age** - this is the current age of the birds in days (weeks).
13. **Initial birds age** - this is where you enter the age of the birds at placement in days (weeks)
14. The day of the week for the past seven days.
15. The amount fed through Feeder System 1 for the day (should match the preset).
16. Same as 15 but for Feeder System 2 (example - male feeder).
17. **Water** - this is the water usage for each of the past seven days.

* **{Note}** — | **This input can be received from any water meter that has electrical output. Check with your Chore-Time distributor for compatible meters. This communication is established in Setup and Calibration — BUTTON 14.**

18. **Mortality** - this is the mortality for each of the past seven days. Since there is only room for one entry, this is the combined total mortality per day for both groups of birds.
19. **Total Eggs** - this represents the total eggs for each of the past seven days.
20. **Hatching Eggs** - this represents the hatching eggs for each of the past seven days.
21. **Reset Registration** - this resets history data for beginning of new flock.

* **{Note}** — | **When the control is linked to a PC, more data beyond seven days can be stored.**

8

Alarms

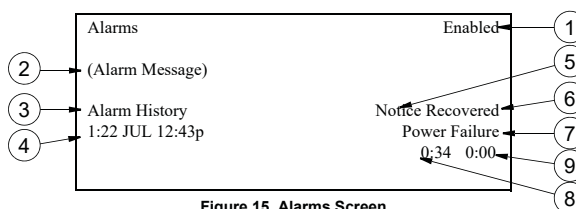

Figure 15. Alarms Screen

The *Alarms screen* is designed as an aid to inform you that conditions are not correct, or presets have not been met. When conditions reach an alarm level, the light next to **BUTTON 8** will begin to flash, and you will get a message in screen 1 to “Check Alarms”. A relay will activate a siren or dialer or any other external device you have selected for your operation. When this occurs, Press **BUTTON 8** which will open the screen and inform you of the alarm condition. At the same time it will deactivate the relay. The light will continue to flash and “Check Alarms” will continue to show in screen 1 until the conditions have recovered.

1. Alarm System Status
 - Enabled (or on)
 - Disabled (or off)
 - Test (which will sound your audible system and activate the visual indicators)
2. This describes the alarm condition as defined below.
3. **Alarm History** - this lists the last ten alarm conditions with the most recent at the top.
4. Date and time alarm condition occurred.
5. Elapsed time from when alarm occurred to when it was noticed by pushing **BUTTON 8**.
6. Elapsed time from when alarm occurred to when condition was corrected.
7. Description of alarm condition.
8. Time it took to notice in minutes
9. Time it took to recover in minutes.

Alarm - continued

Possible alarms discussed:

1. **Power Failure** - if you lose power, you will get an alarm condition.
2. **Weigh Fill 1 (2) Presets Not Met** - if the preset to the Weigh Bin is not completed within the allotted time established in screens "2" and "9". This will create an alarm condition. This alarm condition can be caused by:
 - a. The run time not being adequate.
 - b. A malfunction in the delivery system.
3. **Flow Error** - If there is no increase in weight during a short, specified period of time, the control will turn off the fill system. It will restart, and if there still is no increase it will go through this cycle two more times. If there still is no change, it will shut the auger down and activate the alarm. Causes for this condition can be:
 - a. Supply bin out of feed.
 - b. Feed bridge in the supply bin—this is the purpose for starting and stopping, to attempt to break the feed lose.
4. **Weigh Bin 1 (2) Not Empty** - an alarm will be activated if the weigh bin doesn't indicate empty within the prescribed run time in screens "3" and "10". Causes for this situation can be:
 - a. Bridging in weigh bin.
 - b. Birds not consuming feed in anticipated time.
 - c. A malfunction in the delivery system.
 - d. A malfunction in the feeding system.
 - e. System run time inadequate.
5. **Feeder Fill 1 (2) not completed** - same as #4 except preset is being satisfied by the supply bin and a weigh bin is not being used.

* **{Note}**

If the alarm message is a group of number's, the problem deals with the internal workings of the control and does not reflect problems within your house. If an alarm code appears in this space, notify your local distributor and advise him of the code.

9**Weigh Bin Fill 2 or Spare Timer 2**

See *Weigh Bin Fill 1 or Spare Timer 1 screen* — *BUTTON 2* previously discussed in this manual.

10**Feeder System Fill 2**

See *Feeder System Fill 1 screen* — *BUTTON 3* previously discussed in this manual.

11**Feeder 2**

See *Feeder 1 screen* — *BUTTON 4* previously discussed in this manual.

12**Water Clock**

See *Light Clock screen* — *BUTTON 5* previously discussed in this manual.

13

Feeding Programs

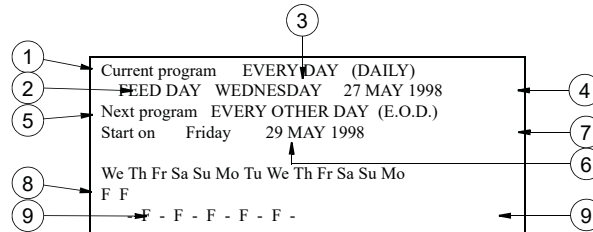

Figure 16. Feeding Programs default Screen

This screen is where you enter the desired feeding program.
Your choices are:

- Every Day
- Every Other day
- 5 of 7 (feed 5 days and skip 2 days during a 7 day cycle).
- 4 of 7 (feed 4 days and skip 3 days during a 7 day cycle).

Sample of Feeding Programs

Mode	Meaning	M	T	W	T	F	S	S
Daily	Feed every day	F	F	F	F	F	F	F
E.O.D.	Feed every other day (skip a day)		F		F		F	
5 of 7	Feed five out of seven	F	F	F		F	F	
4 of 7	Feed four out of 7	F	F		F		F	

1. **Current Program** - this indicates which program is currently being used —i.e. every day, every-other-day, 5-2 and 4-3 (non-editable).
2. This indicates if the current day is a feed or a non feed day (non-editable).
3. This is the current day of the week (non-editable).
4. This is the current day's date (non-editable).
5. This is where you chose what the next program is to be.
6. This is where you indicate when the next program will begin.
7. This indicates the date of the program change (non-editable).
8. This is the feeding schedule for the current day and the following 12 days. The "F" indicates a feed day and a "-" indicates a non feed day.
9. When the schedule drops to the bottom line, this indicates the beginning of a new feeding program

14

Setup

This is probably the most important screen in your control. This is the area that configures your control to meet the needs of your specific house management. If your needs should change in the future, the setup can be modified to meet those needs. **Figure 17.**

* {Note}

Important!

A full understanding of what this screen does is essential before modifying it.

All values below indicate a possible sample situation

1	Control number	1
2	Units of measurement	NON-METRIC
3	Clock Type	12 HR
4	Time of day	8:25a
5	Date	22 Jul 1998
6	CONFIGURATION: Example #	1
7	USE SECONDARY SCHEDULE: Water Light	Yes Yes
8	WEIGH BIN 2 CALIBRATION: Zero Setting	Agreed?
9	Standard Weight = 100	Agreed?
10	Actual Weight = 368	
11	c=-345621 o=374217 s=10231	
12	WATER METER: Gallons Per Pulse	0.00
13	DATA SETUP: Bird Age Unit	Days
14	Data For Eggs	Yes
15	Change Access Code?	No

Figure 17. System Setup and Calibration default screen.

Setup - continued

* **{Note}** — All setups are performed in the *Edit Mode* with the use of the *Navigation Buttons* to move you around to editable positions and the (+) and (-) buttons to make changes and to answer questions.

1. **Control #** - this is where you identify the control being setup. This is important when a PC is part of your system.
2. **Units of Measurement** - metric or non-metric
3. **Clock Type** - if you want to have time of day represented in a 12 hour clock (a.m. and p.m.), or a 24 hour clock format.
4. **Time of Day** - enter the current time.
5. **Date** - enter the current day (DDMMYY).
6. **Configuration** - this is where you indicate the type of Fill, Feeder and Weigh configuration your house has. Choose from the examples given on the following pages, and insert the appropriate number.
7. **Use Secondary Schedule** - when you choose your feeding program in *BUTTON 13* (everyday, E.O.D., etc.) the *Light Clock screen BUTTON 5* and *Water Clock screen BUTTON 12* schedules will follow the same sequence. If you want to vary this—for example water everyday and feed every other day, then answer yes.

* **{Note}** — Steps 8 and 9 calibrate your weigh bin.

8. **Zero Setting** - when the bin or bins being used for weighing are completely empty then you answer “YES” to establish the zero setting calibration.
9. **Standard Weights** - to further calibrate the weigh bin, take a known amount such or 1% or 2% of the bins capacity and suspend it evenly from the bin. Then enter this amount in that space provided and answer “YES”
10. **Actual Weight** - this indicates the actual weight prior to and after calibration. This value is not editable.
11. This area is for diagnostic use and is non-editable.
12. **Gallons Per Pulse** - If you are keeping track of water usage, and you have a device on your water meter that has a pulsed output, enter here what the instructions from the water meter say that each pulse represents. (example gallons or litres)
13. **Bird Age Unit** - in your *Data Screen BUTTON 7*, do you want the bird’s age displayed in days or weeks.
14. **Data For Eggs** - in your *Data Screen BUTTON 7*, are you interested in maintaining data on egg’s. Obviously if this control is used in a Pullet House, the answer is “NO”.

Setup - continued

15. **Access Code (security)** - an access code is available for added security if needed. The access code is a four (4) digit number. This number is entered by using the numbers of the **Subject** buttons.

For example:

*If the access code were "1234", you would press the **Current Conditions** button, **Set Temperature-Timer** button, **Outputs Temperatures** button, and the **Feed Clock** button when asked for the access code.*

From the factory, the Access Code is "1111". This is a special number which causes the control to not ask you for the access code when you first press the **Edit** button.

If you decide to define your own access code, it is done in this area of the setup screen. Answer "yes" to the question, "change access code?", and respond to the screen's question.

If you later decide you don't want to use an access code, you simply change the access code back to "1111". If you forget your access code, call Chore-Time. It is certainly recommended that you write down your access code in a safe place.

Setup - continued

Actual House Layout

1. Fill in the list of relay numbers with device(s) each is controlling.



Relay	Output Controlled
1.	
2.	
3.	
4.	
5.	
6.	
7.	
8.	

Weigh Bin Configurations

* {Note}

1. The following are examples of feeding systems. Choose the example that best describes your operation and insert the number in the *Setup Screen BUTTON 14*.
2. Pullet houses that raise both males and females and are separated, can use one of the breeder examples.
3. The diagrams on the following pages indicate only one fill line per feeding system, but in reality may have dual lines. This will not effect these examples.

**Example 1
Breeder House**

1. Load cells under weigh bin only.
2. Weigh bin supplies female feeder.
3. Supply bin supplies weigh bin and supplies male feeder through hopper type scale.
4. Males and females on same feed.

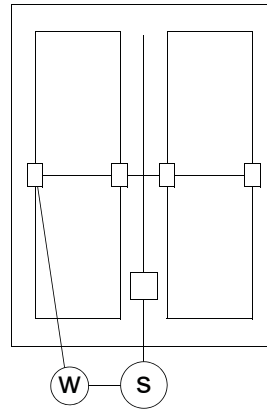

**Example 2
Pullet or Cockerel House**

1. Load cells under weigh bin.
2. Feeding one sex, one feed (can be both sexes mixed but treated as one).

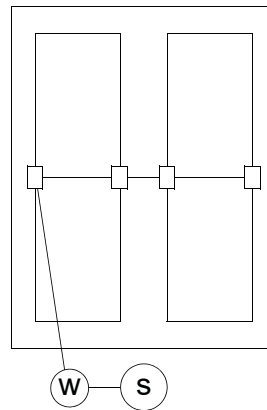

Item	Description
W	Weigh Bin
S	Supply Bin

Weigh Bin Configurations - continued

**Example 3
Breeder House**

1. No weigh bin - load cells under supply bin.
2. Males and Females on same feed.
3. Two separate presets are dispensed from supply bin (no hopper scale for males).

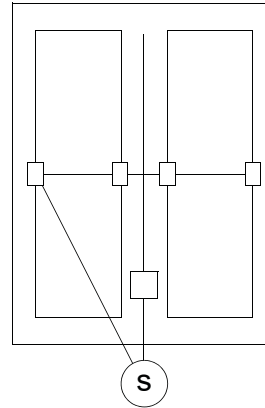

**Example 4
Pullet or Cockerel House**

1. No weigh bin - load cells under supply bin.
2. Feeding one sex, one feed (can be both sexes mixed but treat as one).

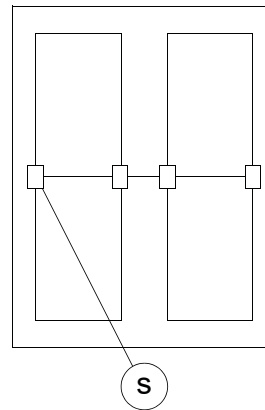

Item	Description
W	Weigh Bin
S	Supply Bin

Weigh Bin Configurations - continued

**Example 5
Breeder House**

1. Load cells under weigh bin.
2. Males and Females on same feed.
3. Two separate presets are dispensed from weigh bin (no hopper scale for males).

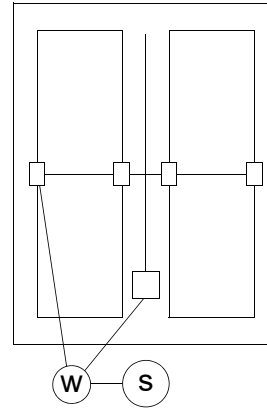

**Example 6
Breeder House**

1. Load cells under weigh bin.
2. Males and Females on separate feed.
3. Male feeder has hopper scales.

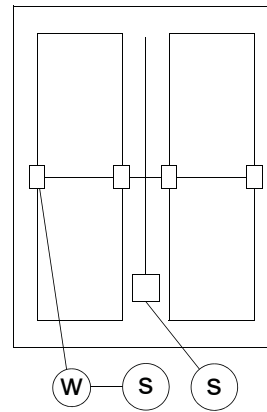

Item	Description
W	Weigh Bin
S	Supply Bin

Weigh Bin Configurations - continued

**Example 7
Breeder House**

1. Load cells under both supply bins.
2. Males and Females on separate feed.

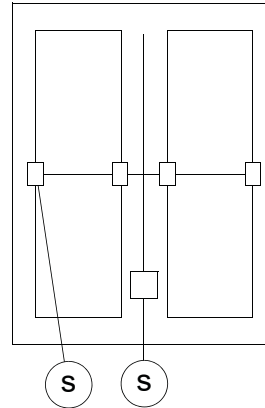

**Example 8
Breeder House**

1. Load cells under both weigh bins.
2. Males and Females on separate feed.

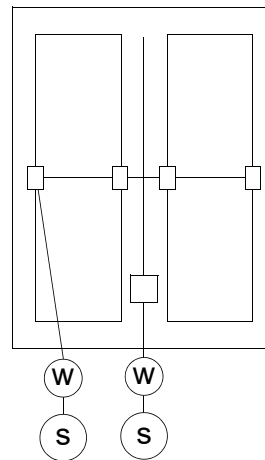

Item	Description
W	Weigh Bin
S	Supply Bin

Weigh Bin Configurations - continued

**Example 9
Breeder House**

1. Load cells under one weigh bin and one supply bin.
2. Males and Females on separate feed.

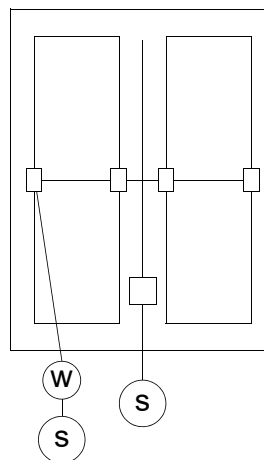

**Example 10
Breeder House**

1. Load cells under one weigh bin and one supply bin.
2. Males and Females on separate feed.

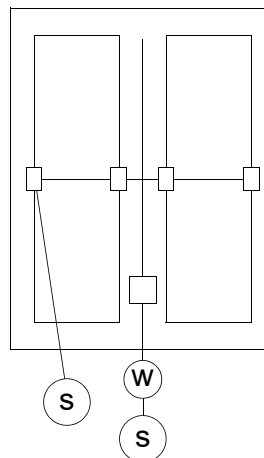

Item	Description
W	Weigh Bin
S	Supply Bin

Weigh Bin Configurations - continued

Example 11 Breeder House

- 1. Load cells under two weigh bins.
- 2. Males and Females on same feed.

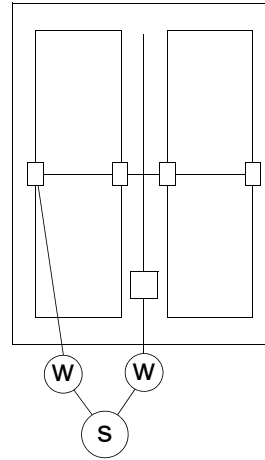

Item	Description
W	Weigh Bin
S	Supply Bin

MS Board Dip Switch Positions

1. Manual Switch position on first board — one board being used

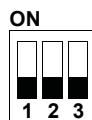

2. Manual Switch position on second board — two boards being used

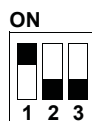

3. Manual Switch position on third board — three boards being used

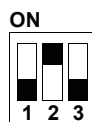

* *{Note}* — New controls will come from the factory pre-set. This information is provided only when a replacement board is used.

Scale Junction Box Add-On's

SJB - SJB1 (Scale Junction Boxes)

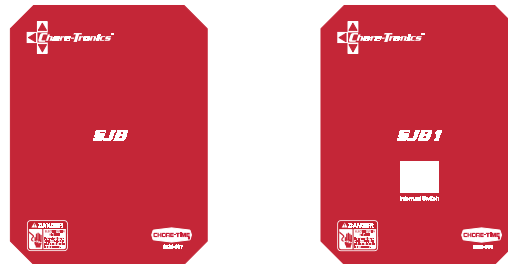

When using a scale system along with your feeder control, you will need a scale junction box (SJB or SJB1) to attach the cables from the load cells, and to transmit a signal to the control. Each SJB comes with a mounting bracket that allows you to mount the box easily to a Chore-Time or Brock Bin.



<Caution>

When mounting the SJB or SJB1 to the bin, always make sure you use water tight connectors and bring your cables through the bottom of the box.

In addition to the cable inputs from the load cells, there will be a cable running to the feeder control. There is no length restriction on the cable and we recommend using our **sensor cable part no. 42208** for this application.

There are two different junction boxes. The one you use depends on the weighing application:

SJB (Scale Junction Box) #40733

This is recommended when your load cells are located under a separate bin from the supply bin.

SJB1 (Scale Junction Box with Interrupt Switch) #41519

If you are weighing and feeding from the same bin (supply bin), then the SJB1 should be used. The SJB1 has an interrupt switch which will temporarily stop the feeder fill system in the event feed is being delivered during the feeding period. This will allow you to maintain an accurate preset calculation.

When the delivery process is completed, the button is pushed again to resume the feeder auger operation. If the button is not pushed a second time, the feeder auger will automatically be activated 60 minutes after it was first deactivated.

See following pages for wiring diagram.

Technical Specifications

This Information is to Follow.

PC Connection Overview

Off-Site PC Connecting to On-Site PC with Controls

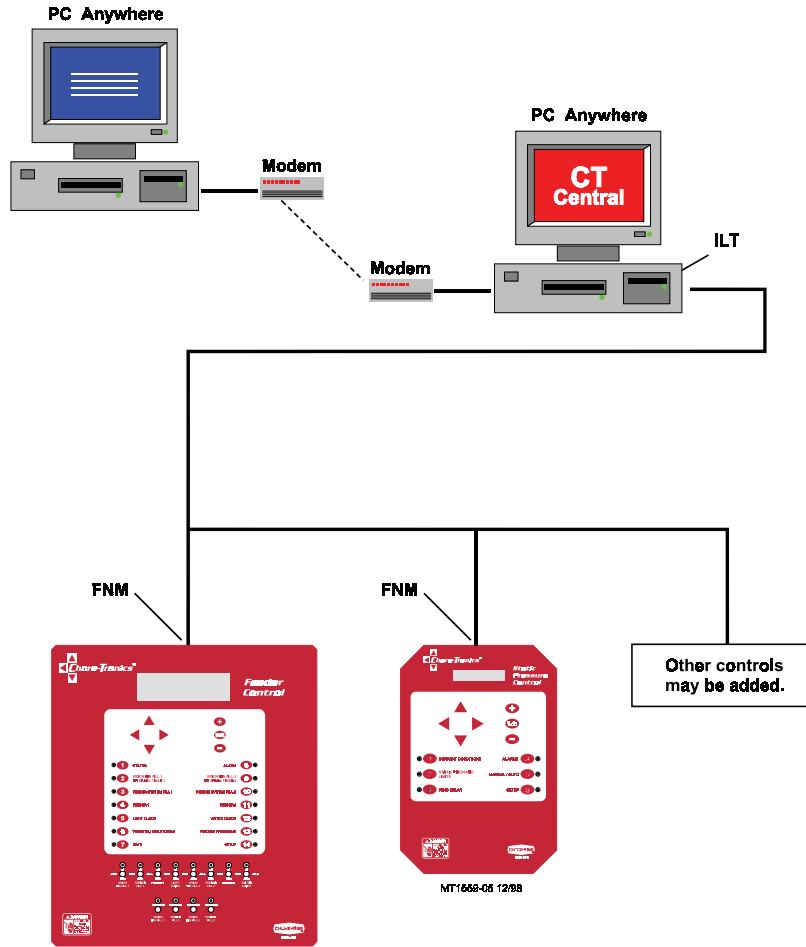

On-Site PC with Controls

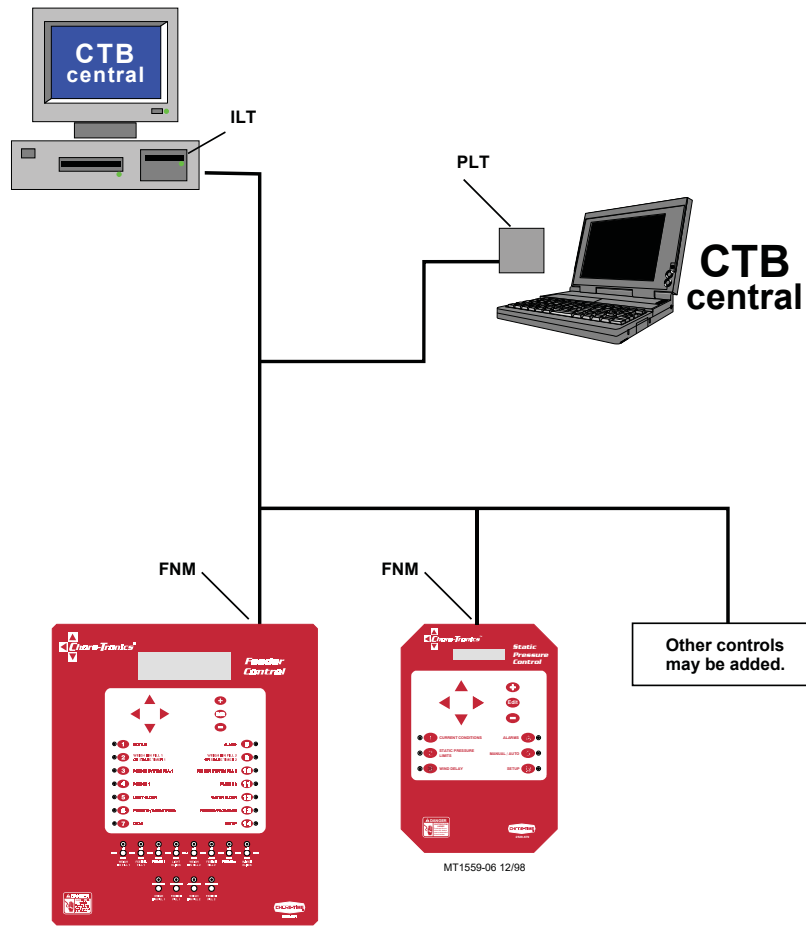

Off-Site PC with Controls

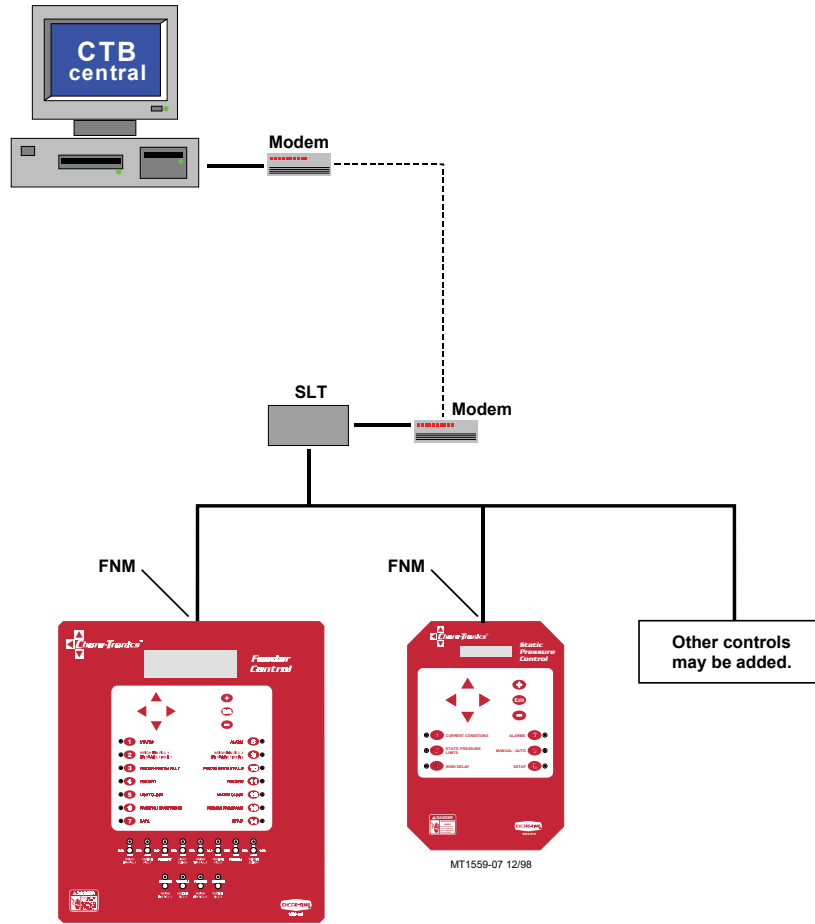

Trouble Shooting

Problem	Possible Cause	Solution
The Screen is blank, but outputs appear to be operating normally.	The screen is defective.	Replace the display.
	The flat cable between the KD board and the screen is defective, loose or disconnected.	Readjust connections or replace cables.
The screen does not respond when pressing any of the Subject Buttons	The KD board is defective.	Replace the KD board.
An output does not respond to its toggle switch or an output does not work under any condition	The relay board is defective.	Replace the relay board.
	The MS board is defective.	Replace the MS board.
	The flat cable between the KD board and the MS board or MS relay board has a problem.	Readjust connections or replace cable.
The control seems completely dead — the screen shows nothing under any condition, and the indicator lights are off	The fuse for incoming power is blown.	Replace the fuse.
	The circuit breaker supplying power to the control is tripped.	Reset the breaker.
	The power supply or I/O board is bad.	Replace the power supply or I/O board.
	The KD board is defective.	Replace
	The flat cable from the power supply board to the IO board or IO board to the KD board is defective.	Readjust or replace.
Relays 1-8 are completely non-functional.	The associated MS board has the wrong address set in its dip switches.	Reset the switch setting.
	The flat cable between the KD board and the associated MS board or that MS board and its relay board is defective or not connected properly.	Readjust or replace.
	The associated MS board is defective.	Replace

Parts Listing

This Information is to Follow.

Installation and Operation of Scale Load Cells

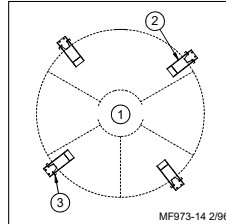

Mount Base.

1. Mount Base - The Mount Base is the heavy, steel frame that the bin leg sets on. The Load Cell is secured within the Mount Base. (T.C. type shown)

2. Load Cell - The Load Cells are the sensing devices of the scale. They mount inside the Base and are secured in place by (2) pins. (T.C. type shown)

3. Top Mount - The Top Mount is the flat steel plate that connects the bin leg to the

Beam Assembly - The Beam Assembly is used on 6-legged bins that are not to be mounted on a bin platform. The (2) Beam Assemblies carry the load of (2) legs each, thus requiring (4) Mount Kits instead of 6. The Beam Assemblies may be used on bins that carry a maximum gross weight of 48,000 lbs (21,773 kg.)

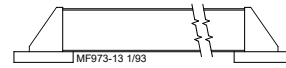

Steel Framing - Steel framing is used in applications that require both feed bins be combined. One scale system is installed beneath the steel framing. (Frame not supplied by Chore-Time)

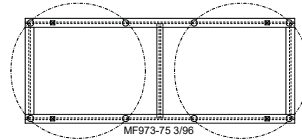

System Planning

Carefully plan the system layout prior to beginning the installation.

The bin should be installed so that no components (such as ladders, conveyors, conduit, etc.) come in contact with the ground or other building structures in a way that would cause an inaccurate weight reading.

The diagrams, on the following two pages show the common system layouts. Refer to the diagram that best fits your particular application.

* {Note}

For bins with six legs, use of Beam Assemblies is recommended to a **Maximum** of 24 tons (21772.8 kg).

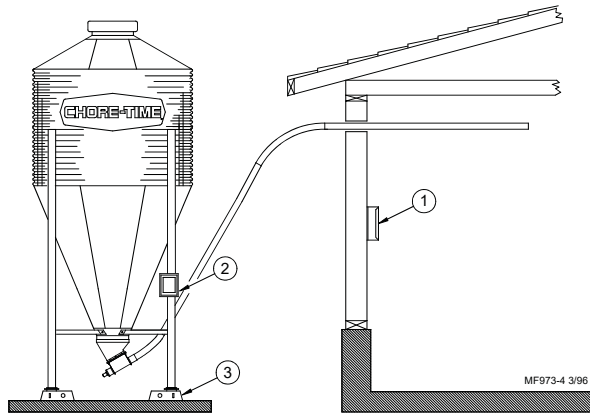

Figure 18. Components layout for 4-Legged Bin (side view)

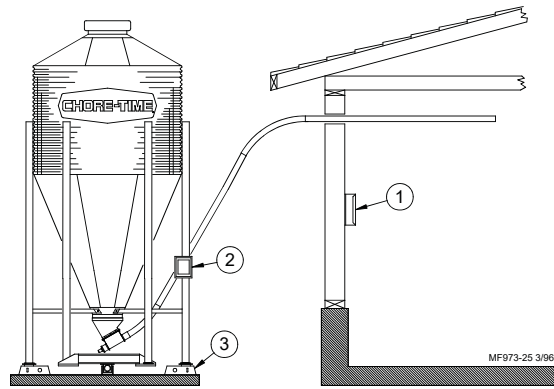

Figure 19. System components layout for 6-Legged Bin (side view)

Key	Description
1	Feeder Control
2	SJB
3	Mount Kit

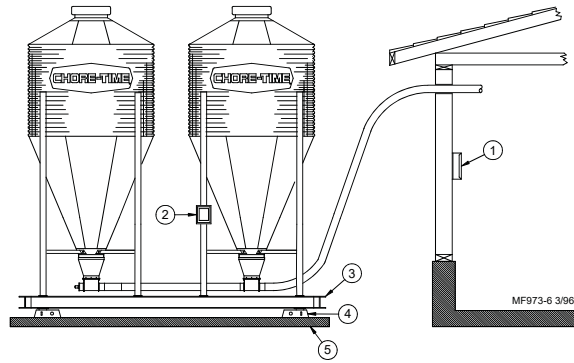

Figure 20. System components layout for (2) Bins and Bin Platform with (4) Load Cells (side view)

Key	Description
1	Feeder Control
2	SJB
3	Bin Platform
4	Mount Kit
5	Concrete Pad

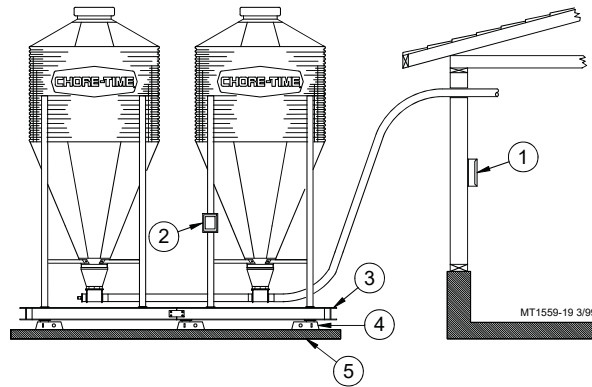

Figure 21. System components layout for (2) Bins and Bin Platform with (6) Load Cells (side view)

Key	Description
1	Feeder Control
2	SJB
3	Bin Platform
4	Mount Kit
5	Concrete Pad

Site Planning

To insure accurate operation, the scales must be installed on a flat, level, well drained surface. Chore-Time recommends setting the scales and bins on a 12" (305 mm) thick concrete pad. Consult your feed bin manual for concrete specifications.

Allow concrete to harden completely before anchor bolt holes are drilled.

Refer to the Flex-Auger Installation Manual and the Feed Bin Assembly Manual to determine bin-to-building placement.

For installations that require a storage bin to fill a Weigh Bin, some dimensional specifications are provided (See Figures 20-23). For ease of installation and most trouble-free operation, the Weigh Bin should be located directly in line with the FLEX-AUGER Delivery System. Some installations may require the storage bin to be placed at 90 degrees to the fill system. This type of installation is acceptable.

Typically, the Weigh Bin is set 8 to 10 feet (2.4 to 3 m) from the building. This varies somewhat depending on the desired height of the FLEX-AUGER System inside the building. Two 45 degree PVC elbows and one 10 foot (3 m) PVC tube are required to go between the Weigh Bin and the building. To place the bin nearer to or farther from the building, additional tubes or elbows may be required.

*** {Note}** — One pad should be used for installations that require a Bin Platform. Refer to the Bin Platform Information and Specifications on pages 53 through 58.

Bin Pad Locations and Dimensions

7' Storage Bin & Weigh Bin using (2) Pads

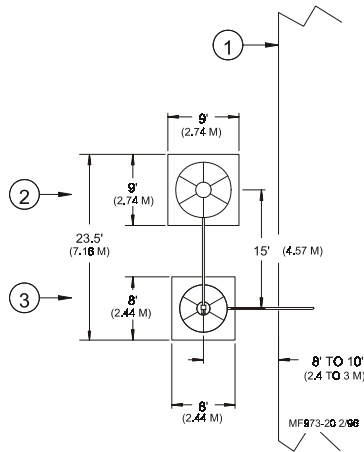

Figure 22. Bin Pad Layout and Position Diagram (top view)

Key	Description
1	House
2	7' Dia. Storage Bin
3	Weigh-Bin

9' Storage Bin & Weigh Bin using (2) pads

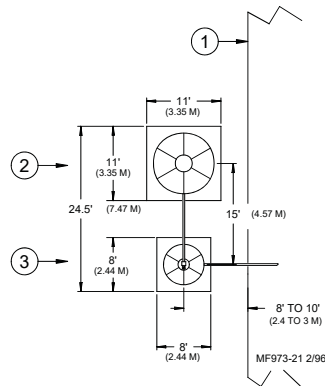

Figure 23. Bin Pad Layout and Position Diagram (top view)

Key	Description
1	House
2	9' Dia. Storage Bin
3	Weigh-Bin

7' Storage Bin & Weigh Bin using (1) pad

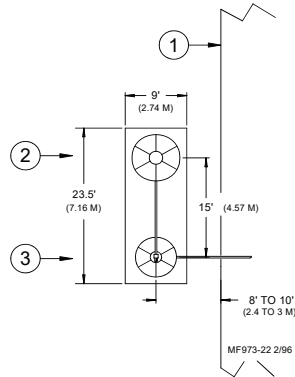

Figure 24. Bin Pad Layout and Position Diagram (top view)

Key	Description
1	House
2	7' Dia. Storage Bin
3	Weigh-Bin

9' Storage Bin & Weigh Bin using (1) pad

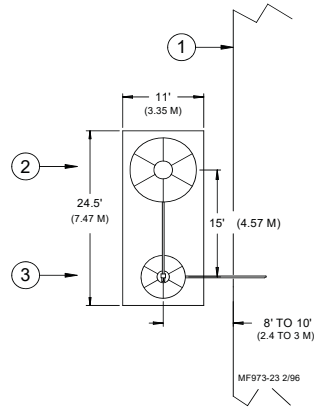

Figure 25. Bin Pad Layout and Position Diagram (top view)

Key	Description
1	House
2	9' Dia. Storage Bin
3	Weigh-Bin

Bin Platform Specifications

Chore-Time does not supply bin platforms. However, the necessary specifications and dimensions are provided on **pages 53 - 58** to have the bin platforms built locally.

Construction drawings, along with steel specifications, are provided for various sizes of bins and scale capacities. Refer to the applicable diagram for the system you are installing. Please note that some of the bin platforms specify a pivot bracket to allow each half of the platform move freely.

For specifications of bin platforms other than those supplied in this manual, consult your building contractor/engineer.

Bin Platform for:

(2) 7 Foot, 4 Legged Bins

48,000 lbs (21,773 kg) Scale System
 50,000 lbs (22,680 kg) Maximum Capacity

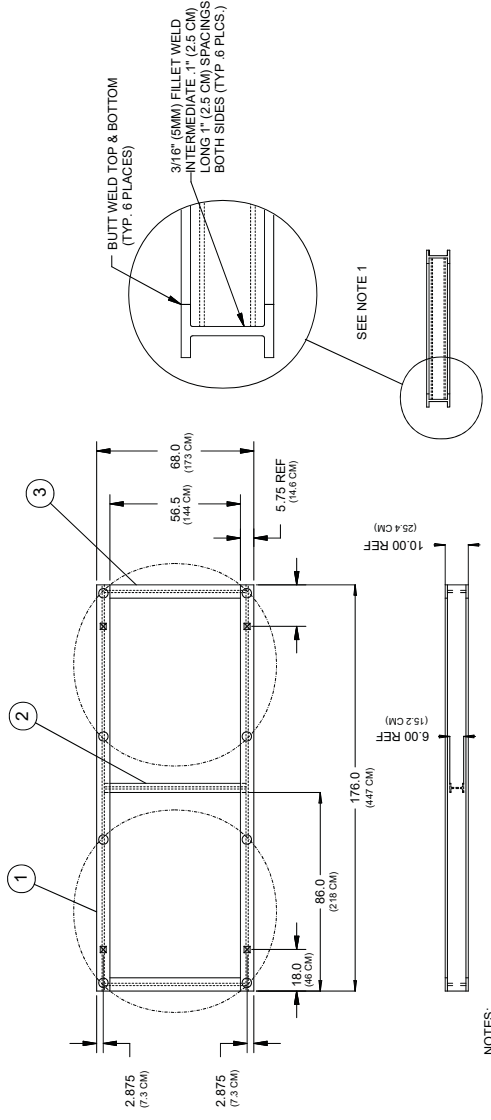

NOTES:

- 1). NOTCH ENDS OF CROSS BEAMS TO NEST INSIDE BEAMS AS SHOWN.
- 2). USE CAUTION TO MAINTAIN FRAME IN FLAT PLANE.
- 3). BIN LEG LOCATION

KEY	QTY	PART NUMBER	DRWG NO.	DESCRIPTION
1	2	-	-	W10X21 LB. BEAM 176.0 LG
2	1	-	-	W6X12 LB. BEAM 62.0 LG
3	2	-	-	W10X21 LB. BEAM 62.0 LG

(30193)
BIN PLATFORM
 2-7'-4 LEGGED 50,000#CAP.
 MF573-39-894

12 Foot, 8 Legged Bins

60,000 lbs (27,216 kg) Scale System
 72,000 lbs (32,659 kg) Maximum Capacity

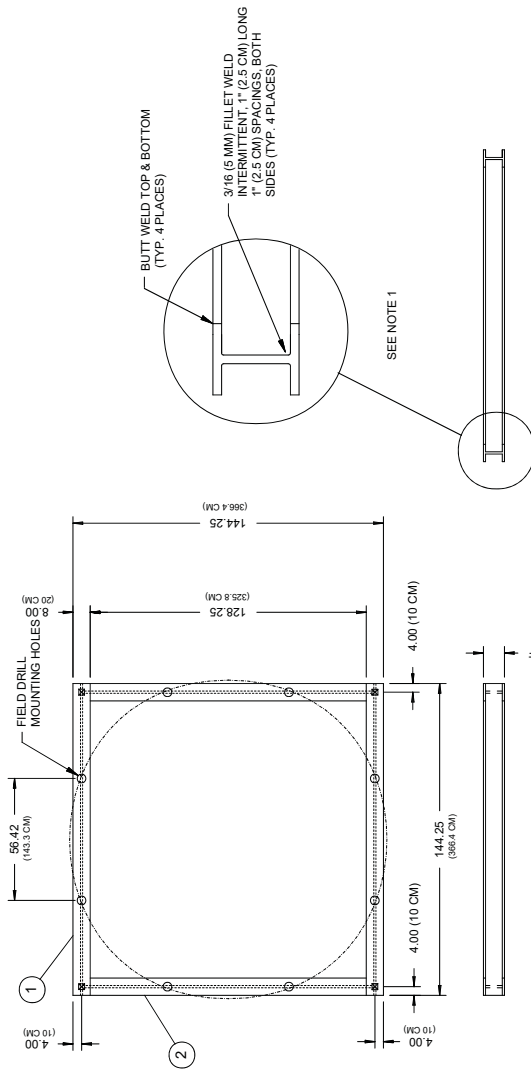

(3/195)
BIN PLATFORM
12' 8-LEGGED, 72,000# CAP.
 MF973-38 8/94

QTY	PART NUMBER	DRWG. NO.	DESCRIPTION
1	-	-	W10X33LB STL BEAM 144.25
2	-	-	W10X33LB STL BEAM 136.0

- NOTES:
- 1). NOTCH ENDS OF CROSS BEAMS TO NEST INSIDE BEAMS AS SHOWN.
 - 2). USE CAUTION TO MAINTAIN FRAME IN FLAT PLANE.
 - 3). BIN LEG LOCATION
- ⊗ LOAD CELL LOCATION

(2) 7 Foot, 4 Legged Bins
 60,000 lbs (27,216 kg) Scale System
 72,000 lbs (32,659 kg) Maximum Capacity

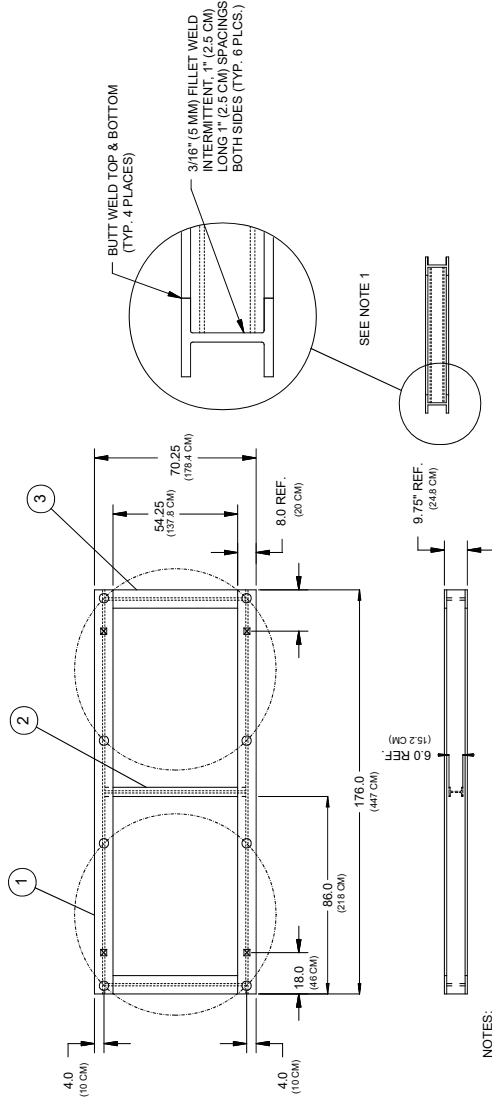

NOTES:

- 1) NOTCH ENDS OF CROSS BEAMS TO NEST INSIDE BEAMS AS SHOWN.
 - 2) USE CAUTION TO MAINTAIN FRAME IN FLAT PLANE.
 - 3) BIN LEG LOCATION
- Ⓜ LOAD CELL LOCATION

KEY	QTY	PART NUMBER	DRWG. NO.	DESCRIPTION
1	2	-	-	W10 X 33 LB. BEAM 176.0 LG.
2	1	-	-	W6 X 12 LB. BEAM 62.0 LG.
3	2	-	-	W10 X 33 LB. BEAM 62.0 LG.

(30185)
BIN PLATFORM
 2-7', 4-LEGGED 72,000# CAP.

MF973-10 894

(2) 9 Foot, 6 Legged Bins

60,000 lbs (27,216 kg) Scale System
 72,000 lbs (32,659 kg) Maximum Capacity

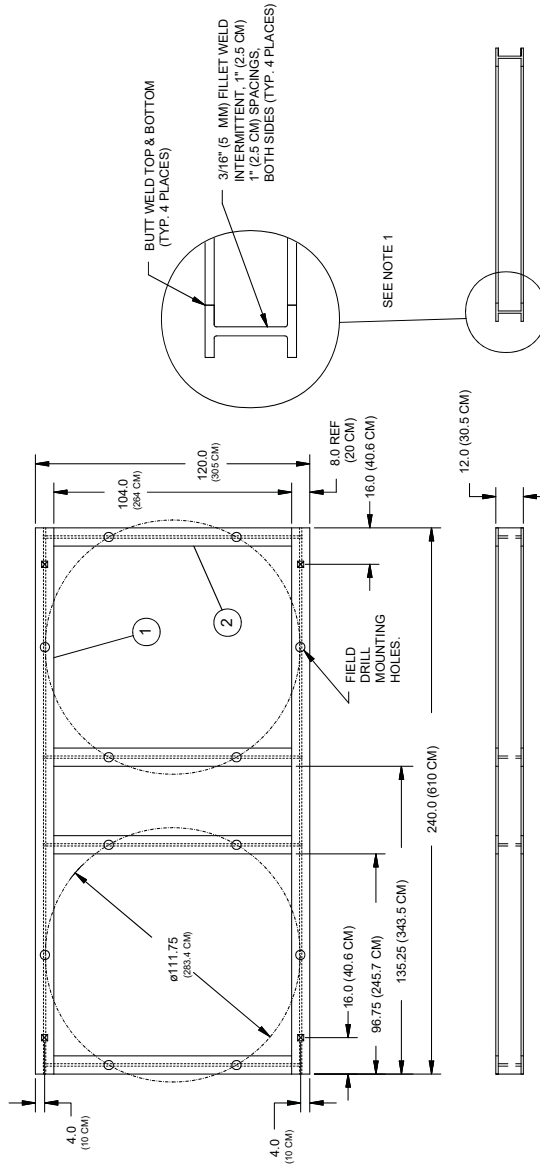

NOTES: 1). NOTCH ENDS OF CROSS BEAMS TO NEST INSIDE BEAMS AS SHOWN.
 2). USE CAUTION TO MAINTAIN FRAME IN FLAT PLANE.
 3). BIN LEG LOCATION
 # LOAD CELL LOCATION

KEY	QTY	PART NUMBER	DRWG. NO.	DESCRIPTION
1	2	-	-	W12 x 40 LB. BEAM 240.0 LG.
2	4	-	-	W12 x 40 LB. BEAM 111.7 LG.

(30180)
BIN PLATFORM
 2-9', 6-LEGGED 72,000# CAP.

MF973-9 894

(2) 9 Foot, 6 Legged Bins
 90,000 lbs (40,824 kg) Scale System
 108,000 lbs (48,989 kg) Maximum Capacity

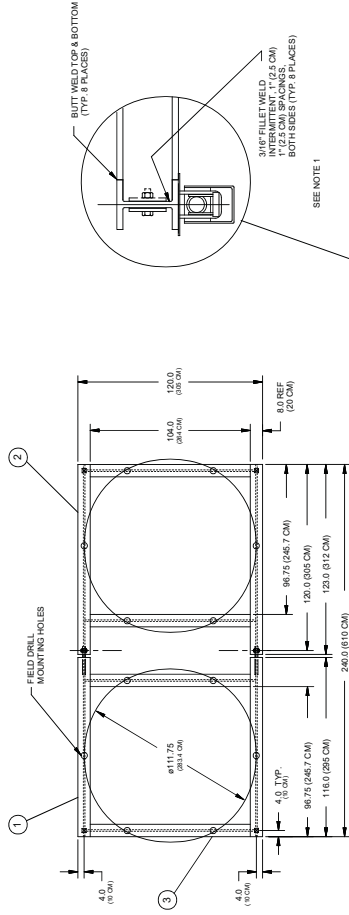

- NOTES: 1) NOTCHES OF CROSS BEAMS TO NEST INSIDE BEAMS AS SHOWN IN PLANT PLAN.
 2) USE CAUTION TO MAINTAIN FRAME IN PLANT PLAN.
 3) BIN LEG LOCATION ■ LOAD CELL LOCATION
 4) INSTALL SHIM (KEY 6) UNDER KEY 4 ONE SIDE OF EACH BEAM TO MAINTAIN CLEARANCE FOR MOUNTING BEAM TO PIVOT.

KEY	QTY	PART NUMBER	DRWG. NO.	DESCRIPTION
1	2	-	-	W10 X 31 LB BEAM 190.0 LG.
2	2	-	-	W10 X 31 LB BEAM 117.0 LG.
3	4	-	-	W10 X 31 LB BEAM 117.0 LG.
4	4	-	-	3/8 X 6 X 1/2 STEEL PLATE
5	2	-	-	1\"/>

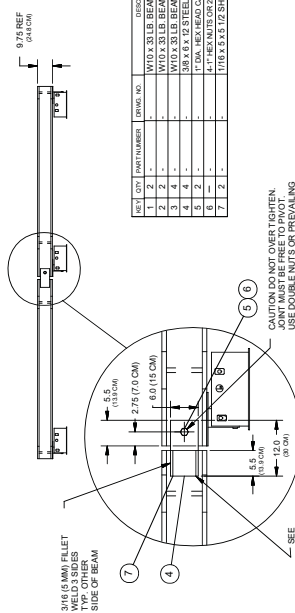

031198
BIN PLATFORM
 24\"/>

(2) 12 Foot, 8 Legged Bins
 90,000 lbs (40,824 kg) Scale System
 108,000 lbs (48,989 kg) Maximum Capacity

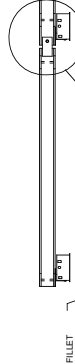
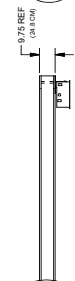
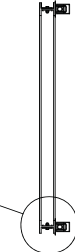
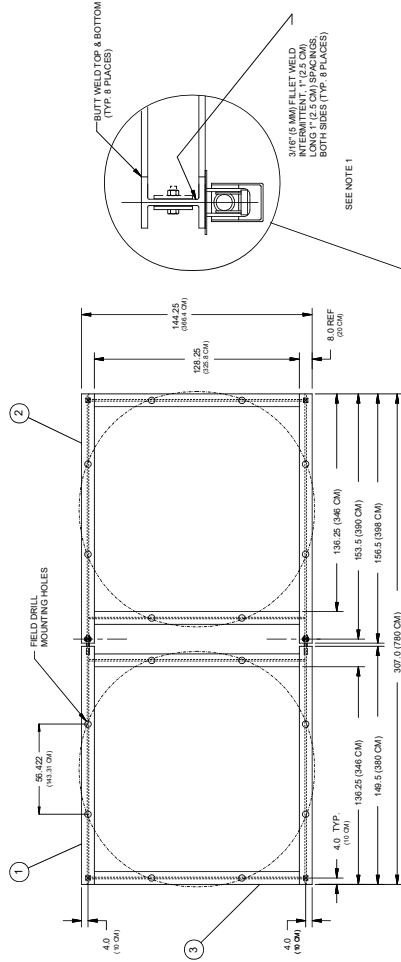

- NOTES:
- 1) NOTCH ENDS OF CROSS BEAMS TO NEST INSIDE BEAMS AS SHOWN.
 - 2) USE CAUTION TO MAINTAIN FRAME IN FLAT PLANE.
 - 3) JOIN LEG LOCATION #LOAD CELL LOCATION
 - 4) INSTALL SHIM (KEY 9) UNDER KEY 4 ONE SIDE OF BIN TO MAINTAIN CLEARANCE FOR MOUNTING BEAM TO PIVOT.

KEY	QTY	PART NUMBER	DESCRIPTION
1	2	-	W/2 X 26 LB. BEAM 156.5 LG.
2	2	-	W/2 X 26 LB. BEAM 156.5 LG.
3	4	-	W/2 X 26 LB. BEAM 156.0 LG.
4	2	-	3/8 X 1/2 X 1/4 SHIM 15.5 LG.
5	2	-	3/8 X 1/2 X 1/4 SHIM 15.5 LG.
6	2	-	1/2\"/>

KEY 9
 BIN PLATFORM
 2-1/2\"/>

MPF7-5-49 10/98

CAUTION DO NOT OVER TIGHTEN JOINT MUST BE FREE TO PIVOT. USE DOUBLE NUTS OR PREVENTING TORQUE LOCKING IS TO SECURE BOLT.

SEE NOTES

Load Cell Mount Height

T.C 15 Mount

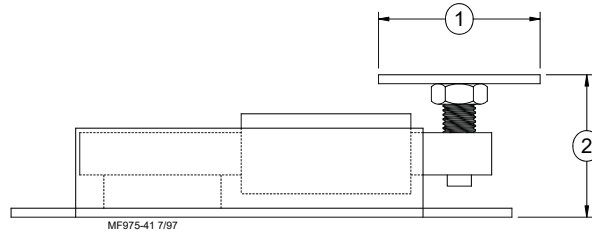

Key	Description
1	5.00" (12.7 cm)
2	4.00" (10.16 cm)

T.C. 125 and T.C. 35 Mount

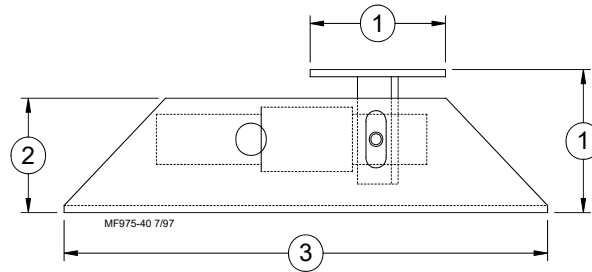

Key	Description
1	5.00" (12.7 cm)
2	4.00" (10.16 cm)
3	17.88" (45.42 cm)

T.C. 180 Mount

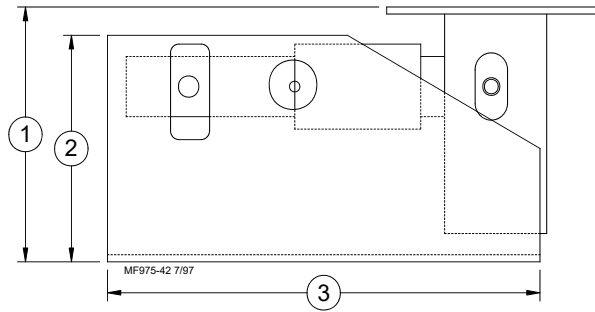

Key	Description
1	9.00" (22.86 cm)
2	8.00" (20.32 cm)
3	15.88" (40.34 cm)

C.T 30 Mount

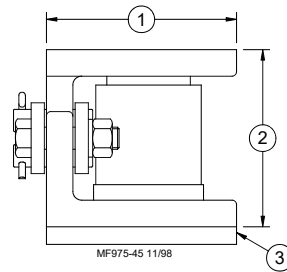

Key	Description
1	5.80" (14.73 cm)
2	5.00" (12.70 cm)
3	.50" (1.27 cm) Mount Plate

Installation of the Scale Components

Step 1: Mount Base Location

Refer to the feed bin assembly instructions to determine the exact dimension between the bin legs.

Lay the Mount Bases in their final locations so that a Top Plate is directly under each feed bin leg. See **Figure 26**.

Secure the Mount Base to the concrete with the concrete anchors supplied. The T.C. 15 uses 7/16" concrete anchors. All others use the 1/2" concrete anchors.

Secure a Top Mount to each bin leg, using 1/2" hardware supplied.

If the bin legs must be welded to the Top Plate, be careful not to damage the Load Cells (or other components) during welding. Later in the installation, it may be necessary to install some shims between the bin and the Top Mount, therefore welding is not recommended.

* {Note}

If welding is required, clamp welding ground cable to bin leg (not to the Load Cell Mount).

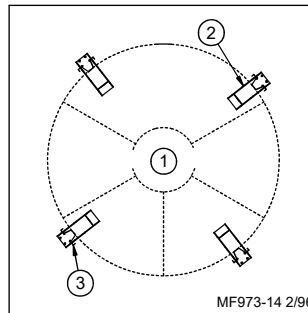

Key	Description
1	Feed Bin
2	Mount Base
3	Bin Leg

Figure 26. Mount Base Location (top view)

Step 2: Mount Base Assembly and Installation (for T.C. Load Cells)

For ease of installation, lubricate the long end of the Load Cell and the Mount Tube with grease.

Install the long end of the Load Cell in the Mount Tube as shown in **Figure 27**. The Load Cell should be retained in the Mount Tube using a 3/4" pin, supplied.

Route the cable through either of the 1" (25 mm) holes in the side of the Mount Base.

*** {Note}** — Refer to the decal on the Load Cell to determine proper orientation of the Load Cell in the Mount Base.

Set the bin on the Mount Bases and secure the Top Mounts to the Load Cell using the 5/8" pins supplied.

When the bin is empty, each mount must equally share the load. Use the shims, supplied with the bin, to evenly distribute the weight. The shims should be located between the bin leg and the Top Mount.

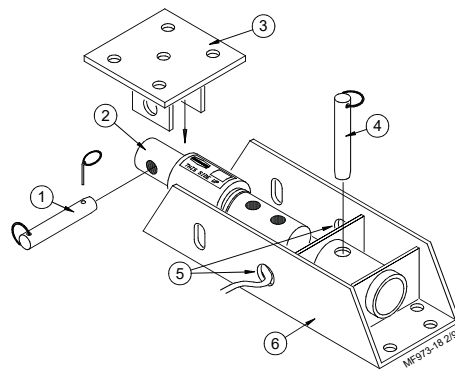

Key	Description
1	5/8" x 5" Quick Pin
2	1-7/8" DB or 2-1/8" DB
3	Top Mount
4	3/4" x 6" Quick Pin
5	Route Cable Through Either Hole
6	Mount

Figure 27. T.C. Mount Base Installation

Step 2: Mount Base Assembly and Installation (for C.T. Load Cells)

1. Clean Mounts and load cells of all dirt and foreign materials.
2. With steel plate (item 11) on bin pad between load cell mount and bin pad, tighten bolts (items 4 and 13) as required.
3. Make sure sealing ring (item 6) and pads (item 12) are not damaged. Replace as needed.
4. Check to see that all load cell cables are tied to frame as they are routed to junction box. Also check for cuts and cracks in the cables.
5. Check for vertical alignment. All load cells (item 5) should maintain vertical alignment during entire loading and unloading process. If misaligned, realign load cell mounts (item 2) as required.

* **{Note}** — Side bar (item 14) is threaded to receive bolts. It is important that bolts (item 8) not be tightened all the way. Leave 1/8" clearance for side bars (items 7 and 14) to move freely. Install lock washer and nut on bolt (item 8).

6. For proper checking of side loads each mount must be installed rotated relative to the others. i.e.; side bars (items 7 and 14) must point in different directions.

! <Caution> — Do not weld near load cells or cables.

7. Remove load cells or cables from area to be welded. Always disconnect indicator from junction box when welding on frame or bin. When welding on frame, place ground on frame as close as possible to area to be welded. When welding on bin, place ground on bin, if welding current is allowed to pass through load cells, it will damage them.

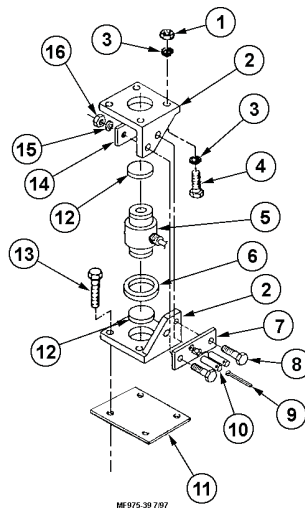

Key	Description
1	5/8" Hex Nut (not supplied)
2	C.T. Mount Half
3	5/8" Lock Washer (not supplied)
4	5/8" Hex Head Bolt (not supplied)
5	C.T. Load Cell
6	Sealing Ring
7	C.T. Mount Welded Plate
8	Hex Head Bolt
9	Cotter Pin
10	C.T. Mount Pin
11	Steel Plate
12	Rubber Shim
13	5/8" Concrete Anchor (not supplied)
14	C.T. Mount Threaded Plate
15	Lock Washer
16	Hex Nut

Figure 28. C.T. Mount Base Installation

Step 3: SJB Location & Installation

The SJB is water resistant, but not water proof. Mount the SJB on a bin leg, nearby wall or other structure, using hardware supplied. See **Figure 29**.

The SJB must be mounted close enough to the Mount Bases so that each individual cable will reach the SJB.

Ground the SJB and Power Supply to a nearby ground rod. Connect the ground cable to the round position of Power Supply and SJB.

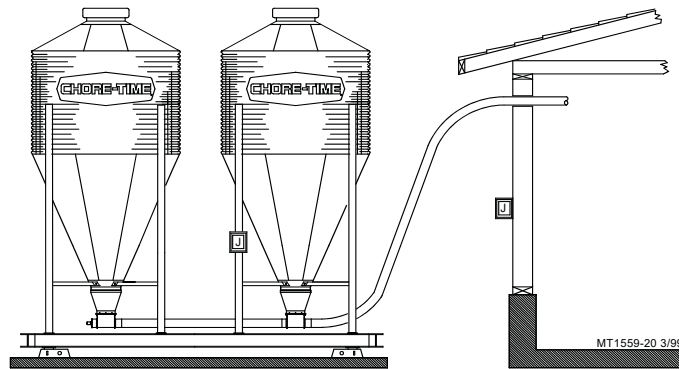

 THIS SYMBOL REPRESENT ALTERNATIVE MOUNTING LOCATIONS. CHOOSE ONE.

Figure 29. Mount Base Installation (side view)

Grounding for the SJB and the Feeder Control.

Shown below is the grounding recommendation for the SJB and the Feeder Control. The recommended method is shown with the solid lines and the optional method is shown with the dashed lines. Ground stakes should be located as shown.

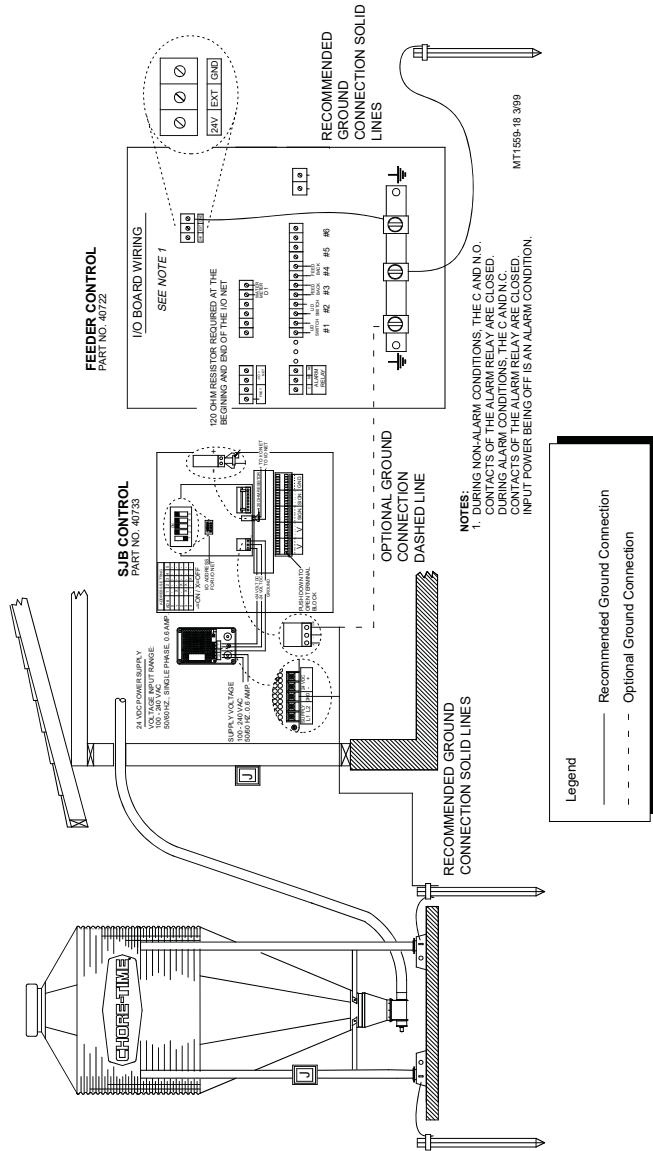

Step 4: Properly Coiling the Cables

The excess SJB and Load Cell Cables must be non-inductively coiled as shown, below. Note that when coiled in this manner, there will be an equal number of right hand and left hand coils. See Figure 30.

*** {Note} — DO NOT CUT THE CABLES.**

Use wire ties to secure the excess cable coils to the bin structure, as shown.

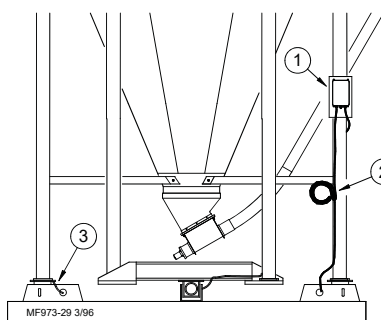

LOAD CELL CABLES MUST NOT BE CUT

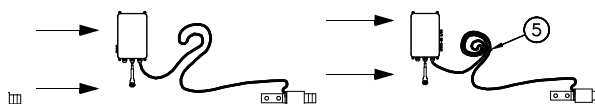

Key	Description
1	Junction Box
2	Coil the excess cable and wire tie to bin leg
3	Carefully route the cable along the bin framing
4	Allow enough cable for drip loop
5	Cable Tie

Figure 30. Cable Routing and Coiling (front view)

Step 5: Grounding the System

Ground Rod Specifications:

The ground rod must be 8' or 2.4 meters long (minimum) and must be free of non-conductive coatings, such as paint or enamel. The ground rod must be made from either: 1) 3/4" (19 mm) diameter or larger galvanized pipe, or 2) 1/2" (13 mm) diameter or larger copper-clad or solid copper rod.

Ground Cable Specifications:

The ground cable must be at least 6 gauge, solid or stranded copper wire. The wire may be insulated, covered or bare, and should be one continuous length with no splices or joints.

The SJB and feed/storage bin must all be grounded to provide lightning protection.

Proper grounding is absolutely required to insure warranty coverage.

Chore-Time recommendations for the number and locations of ground rods required are shown in **Figures 31-33**.

- Standard 4-legged bin requires (2) ground rods. Two legs should be grounded to each ground rod. **See Figure 31.**
- Two (4)-legged bins, with separate scales systems, requires (4) ground rods. Two legs should be attached to each ground rod. **See Figure 32.**
- Single or multiple bins set on scale platform require (2) ground rods. The ground rods should be located at opposite ends of the pad. Only the platform needs to be attached to the ground rod. **See Figure 33.**

The ground rod must be installed so that 8' (2.4 m) of its length is in contact with the soil.

The ground rod should be driven as near as possible to vertical and flush with the ground.

The ground rod should be embedded below permanent moisture level in the soil. If the ground rod cannot be driven further than 5' (1.5 m), contact Chore-Time for additional grounding instructions.

The ground rod should be installed as close as possible to the equipment to be protected.

Multiple ground rods should be located at least 6' (1.8 m) apart.

The ground wire should be kept as short as possible, preferably under 5' (1.5 m). Smooth, gradual bends should be used when routing the cable; avoid sharp corners. Make sure the cable is not restricting the accuracy of the bin in any way.

Connect the ground wire to the rod, and to the metal structure, with cast bronze or brass clamps.

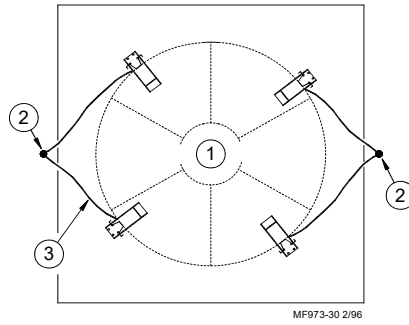

Figure 31. Ground Rod placement for single bin installations (top view).

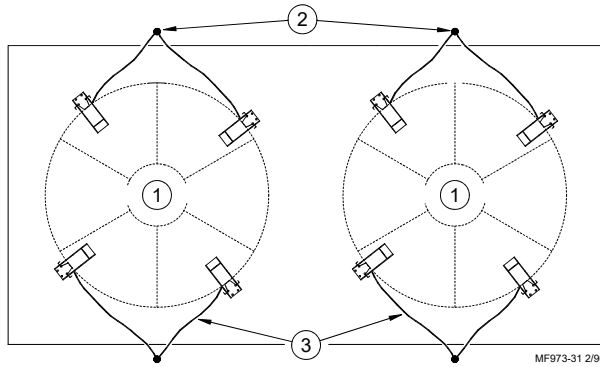

Figure 32. Ground Rod placement for multiple bin installations (top view).

Key	Description
1	Feed Bin
2	Ground Rod
3	Ground Wire: 6 Gauge Maximum Length: 5' (1.2 m)

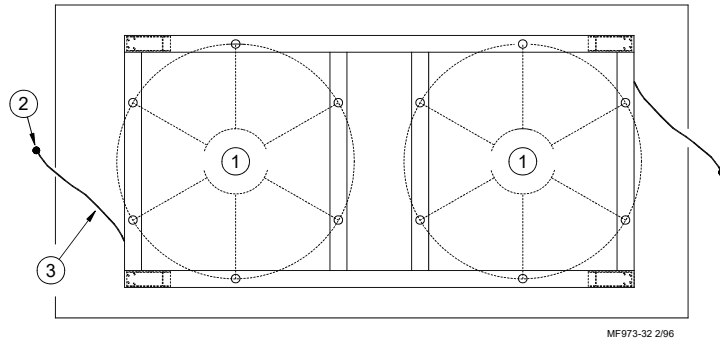
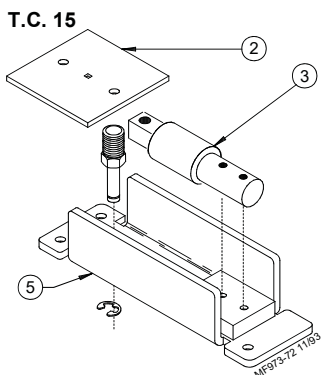

Figure 33. Ground Rod placement for bin platform installations (top view).

Key	Description
1	Feed Bin
2	Ground Rod
3	Ground Wire: 6 Gauge Maximum Length: 5' (1.2 m)

Load Cells and Mount Kits



Item	Description	Part No.
2	Top Plate	----
3	T.C. 15 Load Cell	30219
5*	Mount Kit for T.C. 15	30176

*The Mount Kit does not include Item #3.

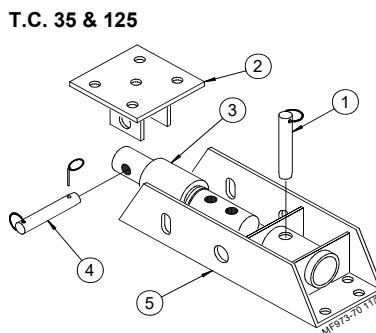

Item	Description	Part No.
1	3/4" x 6" Quick Pin	----
2	Top Plate	----
3	T.C. 35 Load Cell T.C. 125 Load Cell	30221 30222
4	5/8" x 5" Quick Pin	----
5*	Mount Kit for T.C. 35 Mount Kit for T.C. 125	30216 30217

*The Mount Kit does not include Item #3.

T.C. 180

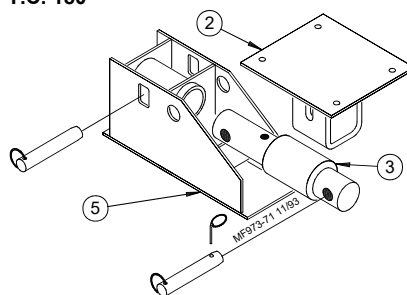

Item	Description	Part No.
2	Top Plate	----
3	T.C. 180 Load Cell T.C. 180 Load Cell w/21' cord	30223 30224
5*	Mount Kit for T.C. 180	30218

* The Mount Kit does not include Item #3.

C.T. 30K

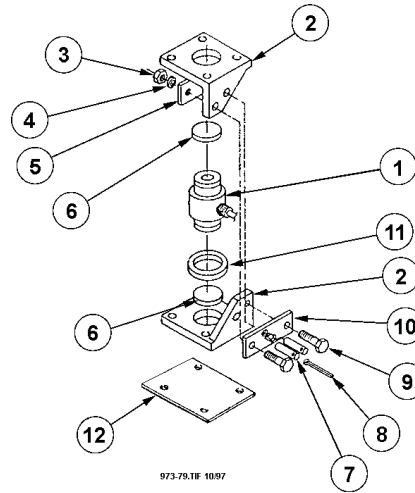

Item	Description	Part No.
1	C.T. 30 Load Cell	35018
2*	C.T. Mount Half	----
3*	M16 x mm Hex Nut	----
4*	M16 Lock Washer	----
5*	Threaded Plate	----
6*	Rubber Shim	----
7*	Pin	----
8*	Cotter Pin	----
9*	M16 x 2 mm x 65 mm Bolt	----
10*	Welded Plate	----
11*	Sealing Sponge Ring	----
12	Steel Plate	----

* Items 2-11 may be ordered as a Mount Kit for C.T. 30 Scale—Part #35017.

Scale Systems available (by weight):

5,000 Lbs.	30209
12,000 Lbs.	30211
48,000 Lbs. (7' Bins)	30213
48,000 Lbs. (9' Bins)	30212
60,000 Lbs.	30214
60,000 Lbs.	34580
80,000 Lbs.	34575
90,000 Lbs.	30215
120,000 Lbs.	35020

Note: Scale Systems include the Junction Box (or Duplex Kit), Load Cells and Mounts. The Digital Indicator must be ordered separately.

6-Legged Bin Adapter Kit

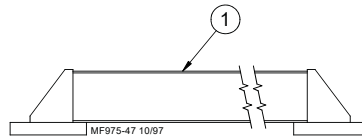

Item	Description	Part No.
1*	Beam Assembly	30183
--*	Beam Assembly Hardware Kit	30184

*The above items may be ordered as a 6-Legged Bin Adapter Kit Part # 30208. This includes (2) Beam Assemblies, (1) Beam Assembly Hardware Kit.

Inspect Junction Box Wiring

1. Connect the Junction Box to the Indicator.
2. Open the Junction Box Cover and check wiring for the following:
 - a. Wires connected to the proper connection point by color code.
 - b. Terminal blocks are clamped onto metal lead not insulation.
 - c. Connections are tight.
3. Check for water or condensation in the Junction Box. If moisture is present, dry the entire box and printed circuit board thoroughly with a hair dryer. Note: If properly wired, there are no hazardous voltages are present in the Junction Box.

Test the Junction Box

Inspect the Junction Box, as specified above, before testing the Junction Box. Test the Indicator and Junction Box using a simulator.

- a. Disconnect all Load Cell wires from Junction Box.
- b. If the failure mode does not change and the Indicator checked out "O.K." earlier, the Junction Box is probably defective.
- c. If the display stops flashing and stabilizes at a weight, the Junction Box is "O.K."

Test the Load Cells

When you are confident the Junction Box and Indicator are working properly, test the Load Cells.

1. Disconnect all Load Cells from the Junction Box.
2. Disconnect the Junction Box from the Indicator.
3. Balance the Indicator.
4. Reconnect the Junction Box. The Indicator should still read close to zero. It should be a steady reading.
5. Connect one Load Cell at a time to any Junction Box Terminal. Be sure the connections are tight and connected to the proper location by color code.
6. Observe a positive weight change after each Load Cell is connected. Record the reading of each Load Cell.

Replacing a CT Load Cell

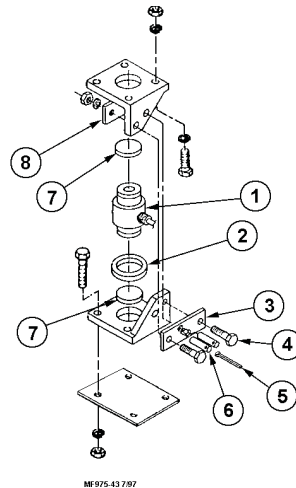

Key	Description
1	C.T. Load Cell
2	Sealing Ring
3	C.T. Mount Welded Plate
4	Hex Head Bolt
5	Cotter Pin
6	C.T. Mount Pin
7	Rubber Shim
8	C.T. Mount Threaded Plate

1. Disconnect load cell from junction box and detach cable from frame.
2. Remove cotter key (item 5) from stabilizer safety pins (item 6) and remove stabilizer pins.
3. Using a hydraulic jack, lift the corner of the bin high enough to remove load cell (item 1).
4. Check sealing ring (item 2) and pads (item 7) to see that they are in good repair. Replace if necessary.
5. Lower corner of bin and reassemble mount.

* **{Note}** — Side bar (item 8) is threaded to receive bolts (item 4). It is important that bolts (item 4) not be tightened all the way. Leave 1/8" clearance for side bars (items 3 and 8) to move freely.

6. Route cell cable to junction box and connect leads.

This Page Currently not in Use.

Wiring Diagram #2

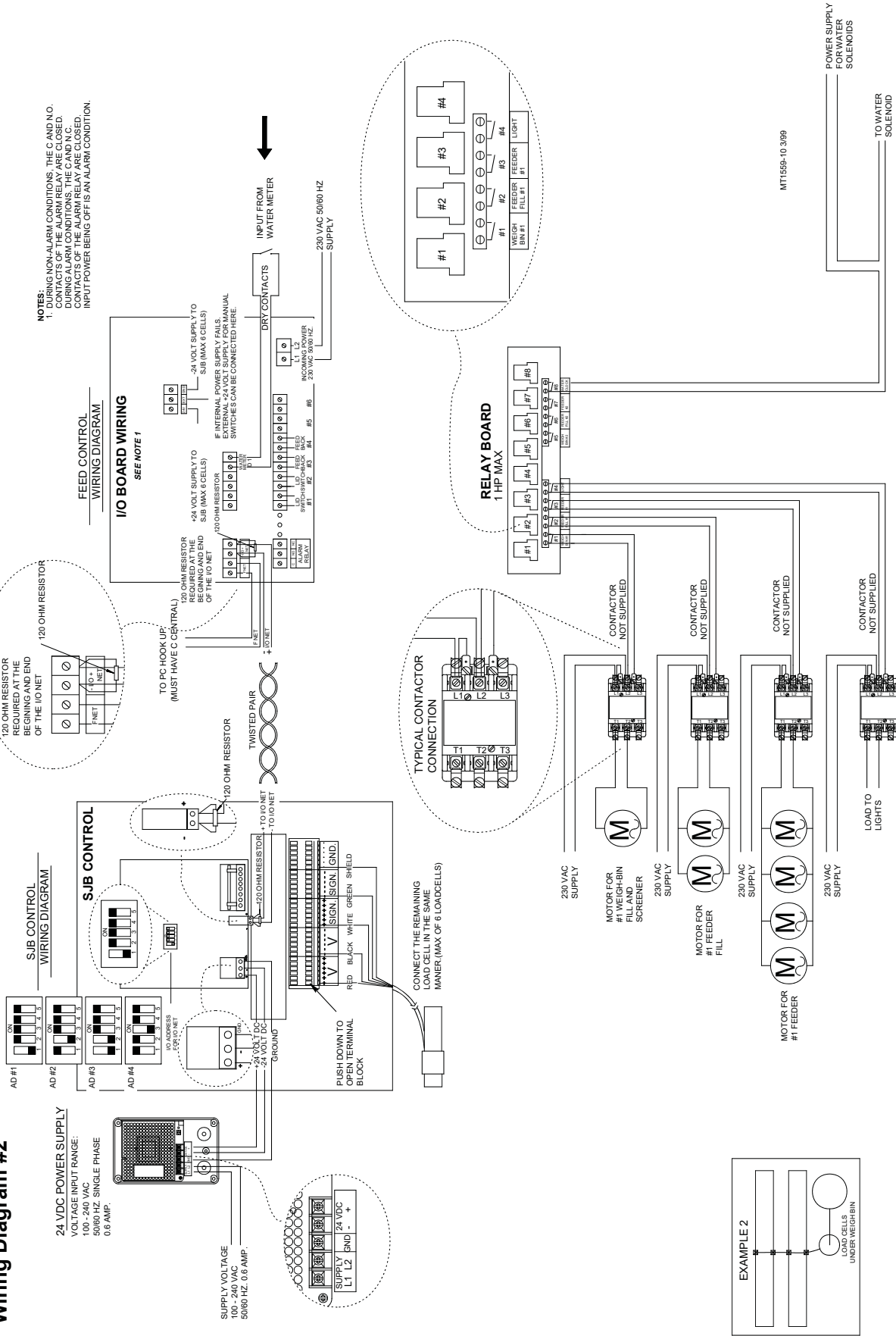

Wiring Diagram #5

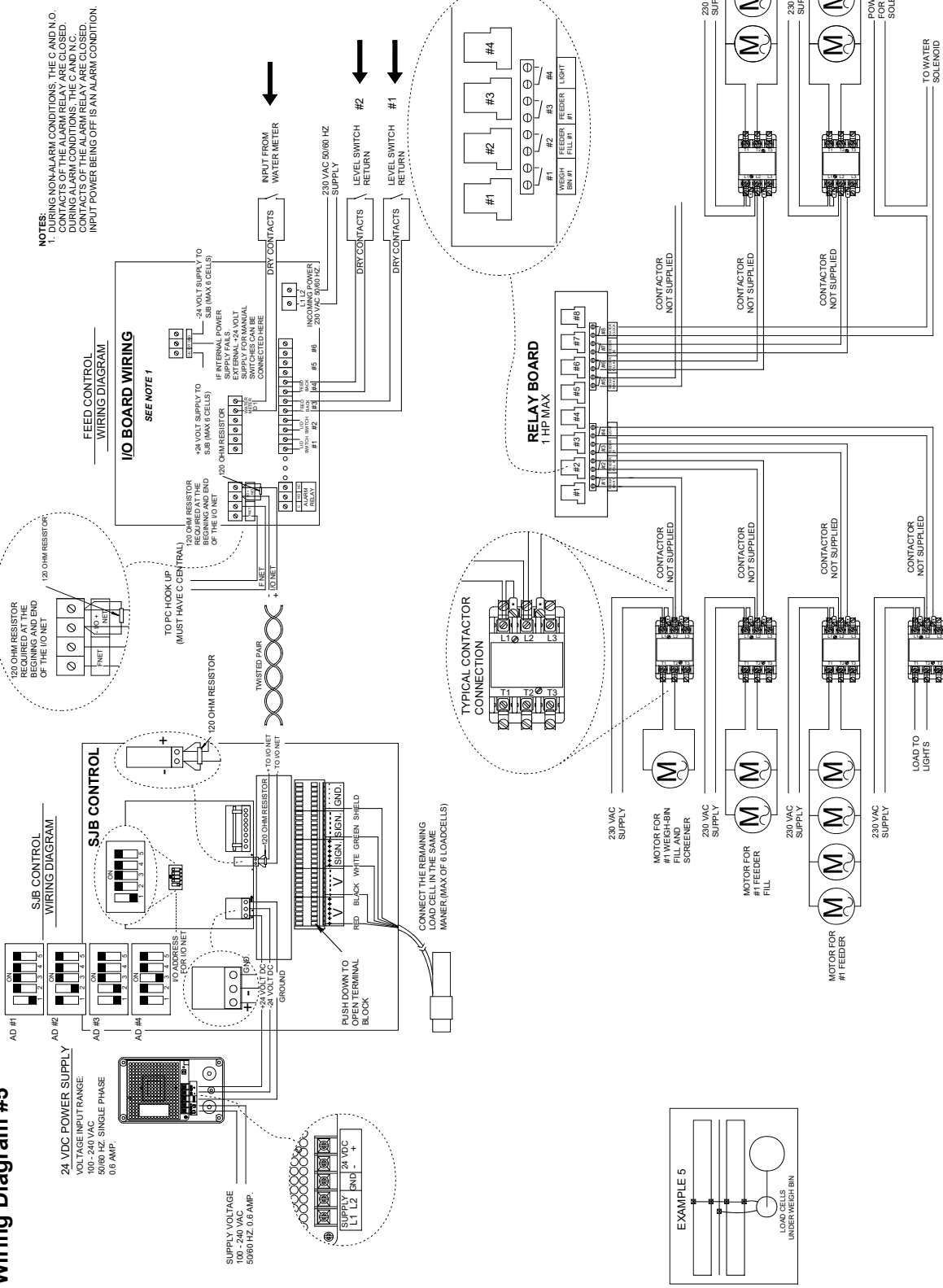

Wiring Diagram #6

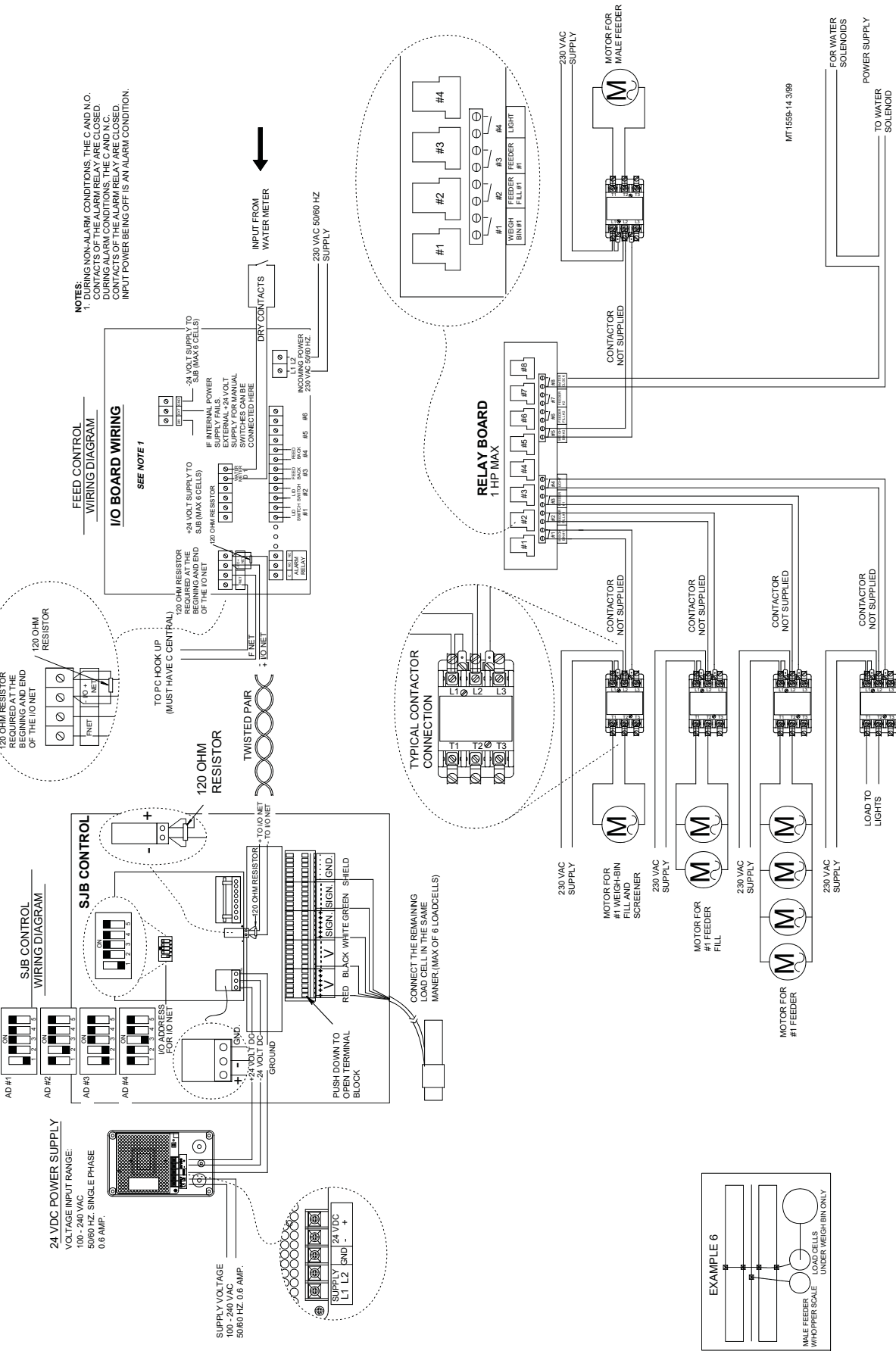



Contact your nearby Chore-Time distributor or representative for additional parts and information.

CTB Inc.
P.O. Box 2000 • Milford, Indiana 46542-2000 • U.S.A.
Phone (219) 658-4101 • Fax (800) 333-4191
E-Mail: ctb@ctbinc.com • Internet: <http://www.ctbinc.com>

Printed in the U.S.A.