



Poultry Production Systems

Model 90 Twin Control Unit Installation Manual

Installation and Operators Manual

Installation and Operators Manual

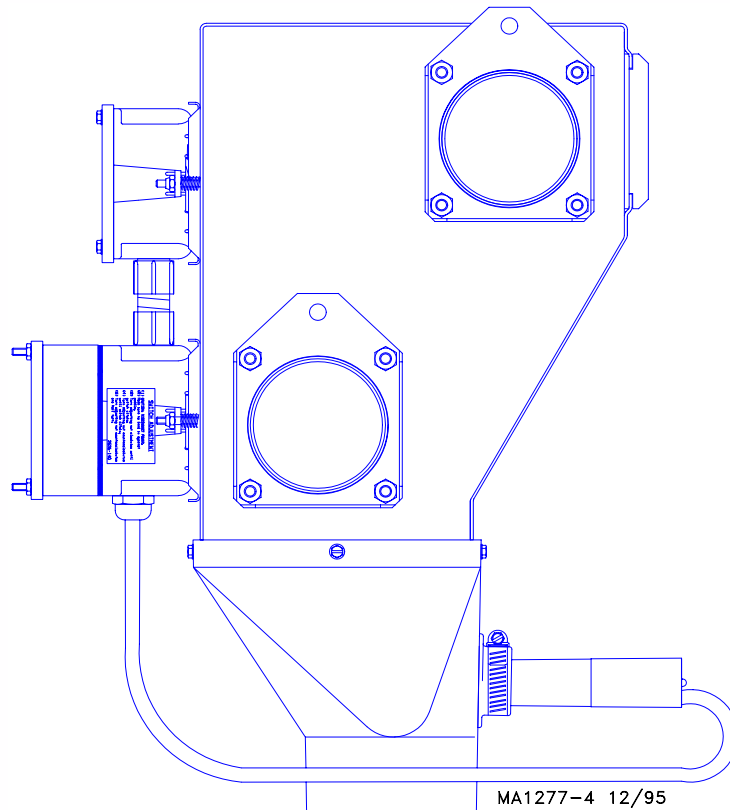

Warranty Information

Chore-Time Equipment, a division of CTB, Inc., ("Chore-Time") warrants each new CHORE-TIME® product manufactured by it to be free from defects in material or workmanship for one year from and after the date of initial installation by or for the original purchaser. If such a defect is found by the Manufacturer to exist within the one-year period, the Manufacturer will, at its option, (a) repair or replace such product free of charge, F.O.B. the factory of manufacture, or (b) refund to the original purchaser the original purchase price, in lieu of such repair or replacement. Labor costs associated with the replacement or repair of the product are not covered by the Manufacturer.

CONDITIONS AND LIMITATIONS

- 1.The product must be installed by and operated in accordance with the instructions published by the Manufacturer or Warranty will be void.
- 2.Warranty is void if all components of the system are not original equipment supplied by the Manufacturer.
- 3.This product must be purchased from and installed by an authorized distributor or certified representative thereof or the Warranty will be void.
- 4.Malfunctions or failure resulting from misuse, abuse, negligence, alteration, accident, or lack of proper maintenance shall not be considered defects under the Warranty.
- 5.This Warranty applies only to systems for the care of poultry and livestock. Other applications in industry or commerce are not covered by this Warranty.

The Manufacturer shall not be liable for any consequential or special damage which any purchaser may suffer or claim to suffer as a result of any defect in the product. "Consequential" or special damages" as used herein include, but are not limited to, lost or damaged products or goods, costs of transportation, lost sales, lost orders, lost income, increased overhead, labor and incidental costs and operational inefficiencies.

THIS WARRANTY CONSTITUTES THE MANUFACTURER'S ENTIRE AND SOLE WARRANTY AND THIS MANUFACTURER EXPRESSLY DISCLAIMS ANY AND ALL OTHER WARRANTIES, INCLUDING, BUT NOT LIMITED TO, EXPRESS AND IMPLIED WARRANTIES AS TO MERCHANTABILITY, FITNESS FOR PARTICULAR PURPOSES SOLD AND DESCRIPTION OR QUALITY OF THE PRODUCT FURNISHED HEREUNDER.

Chore-Time Distributors are not authorized to modify or extend the terms and conditions of this Warranty in any manner or to offer or grant any other warranties for Chore-Time products in addition to those terms expressly stated above.

An officer of CTB, Inc. must authorize any exceptions to this Warranty in writing. The Manufacturer reserves the right to change models and specifications at any time without notice or obligation to improve previous models.

Effective 01/2002

Chore-Time Equipment
A Division of CTB, Inc.
P.O. Box 2000 * Milford, Indiana 46542-2000 * U.S.A.
Phone (574) 658-4101 * Fax (574) 658-4171
Email: ctb@ctbinc.com * Internet: <http://www.ctbinc.com>

Thank You

The employees of Chore-Time Equipment would like to thank your for your recent Chore-Time purchase. If a problem should arise, your Chore-Time distributor can supply the necessary information to help you.

SAFETY INFORMATION

Caution, Warning and Danger Decals have been placed on the equipment to warn of potentially dangerous situations. Care should be taken to keep this information intact and easy to read at all times. Replace missing or damaged safety signs.

Using the equipment for purposes other than specified in this manual may cause personal injury or damage to the equipment.

Safety–Alert Symbol

This is a safety–alert symbol. When you see this symbol on your equipment, be alert to the potential for personal injury. Chore-Time equipment is designed to be installed and operated as safely as possible...however, hazards do exist.



Signal Words

Signal words are used in conjunction with the safety–alert symbol to identify the severity of the warning.

DANGER indicates an imminently hazardous situation which, if not avoided, WILL result in death or serious injury.

WARNING indicates a potentially hazardous situation which, if not avoided, COULD result in death or serious injury.

CAUTION indicates a hazardous situation which, if not avoided, MAY result in minor or moderate injury.



DANGER: Electrical Hazard

Disconnect electrical power before inspecting or servicing equipment unless maintenance instructions specifically state otherwise.

Ground all electrical equipment for safety.

All electrical wiring must be done by a qualified electrician in accordance with local and national electric codes.

Ground all non-current carrying metal parts to guard against electrical shock.

With the exception of motor overload protection, electrical disconnects and over current protection are not supplied with the equipment.

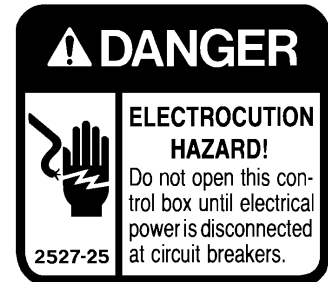

DANGER: Moving Auger

This decal is placed on the Clean-Out Cover of the FLEX-AUGER Control Unit.

Severe personal injury will result, if the electrical power is not disconnected, prior to servicing the equipment.

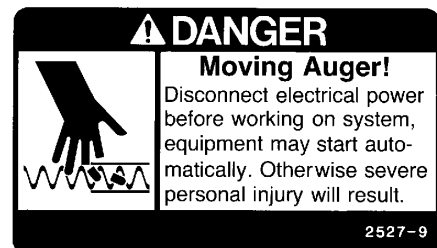

Twin Control Unit Installation

The Model 90 Twin Control Unit is shipped with the Terminal Boxes and Proximity Switch installed.

The Tube Anchors must be installed on the incoming side of the Body Weldment. See Figure 1. Hardware is supplied in the Hardware Package.

Either side of the Body Weldment may be chosen as the incoming side. Position Terminal Boxes to best suit the installation. The (plastic) Drop Weldment may also be rotated to suit installation requirements.

Install the Driver Assemblies on the Output Shafts of the Gearheads. Leave the cap screws (on the side of the Driver Assemblies) loose enough so that the Auger can be threaded through the Anchor Clamp

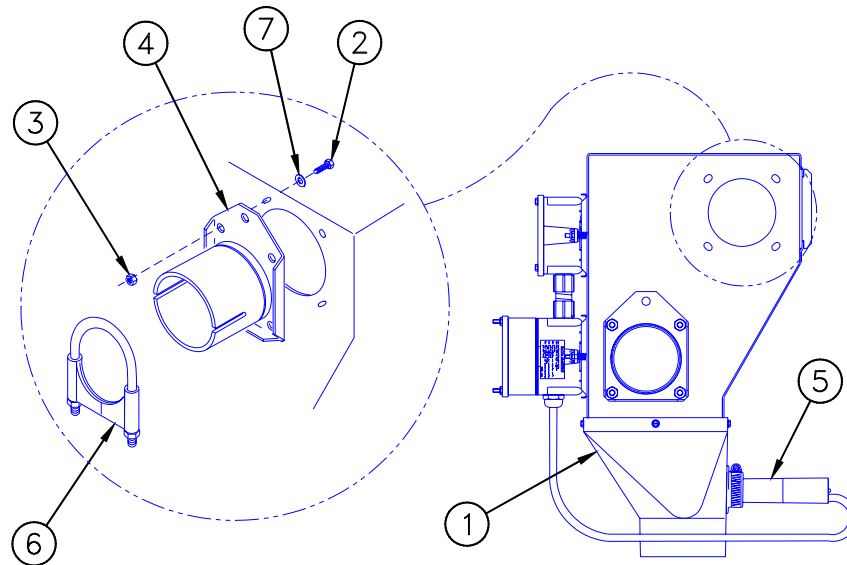

MA1277-2 12/95

Key	Description
1	Twin Model 90 Control Unit
2	5/16-18 Bolt
3	5/16-18 Hex Nut
4	Tube Anchor Weldment
5	Proximity Switch
6	Tube Clamp
7	5/16" Flat Washer

Figure 1. Tube Anchor Installation

later.

Secure the Power Unit/Gearheads to the Body Weldment using 5/16-18 bolts.

Suspend the Control Unit and Motors from the ceiling or trusses at the locations specified in Figure 2.

Insert the Auger Tubes into the Tube Anchors and secure using the clamps provided, as shown in Figure 2.

Use Flexible Tubing to connect the Motors to the Terminal Box to route wires through.

Install the Auger as specified in the Model 55/75/90/HMC FLEX-AUGER Installation Manual (MA1000).

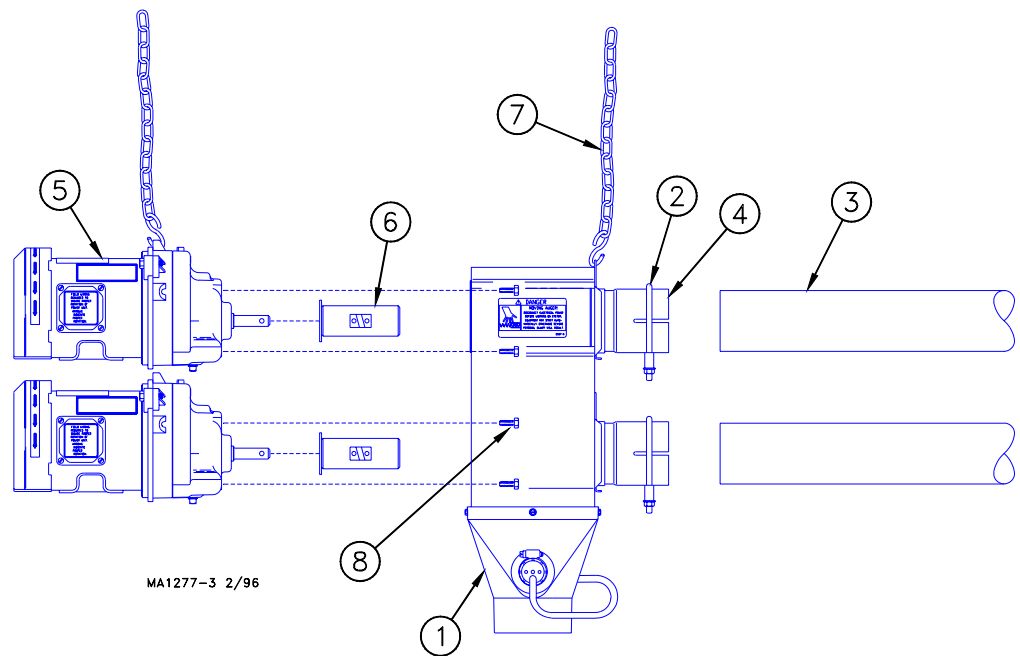

MA1277-3 2/96

Key	Description
1	Twin 90 Control Unit
2	Tube Clamp
3	Auger Tube
4	Tube Anchor Weldment
5	Power Unit
6	Driver Assembly
7	Chain
8	5/16-18 x 3/4" Machine Screws

Figure 2. Power Unit and Auger Tube Installation (side view)

Wire the Twin Control Unit

Refer to the appropriate wiring diagram on pages 6 - 11 for your individual system.

Model 90 Twin Control Unit with Dual Screener

(1-Phase, without Motor Starters)

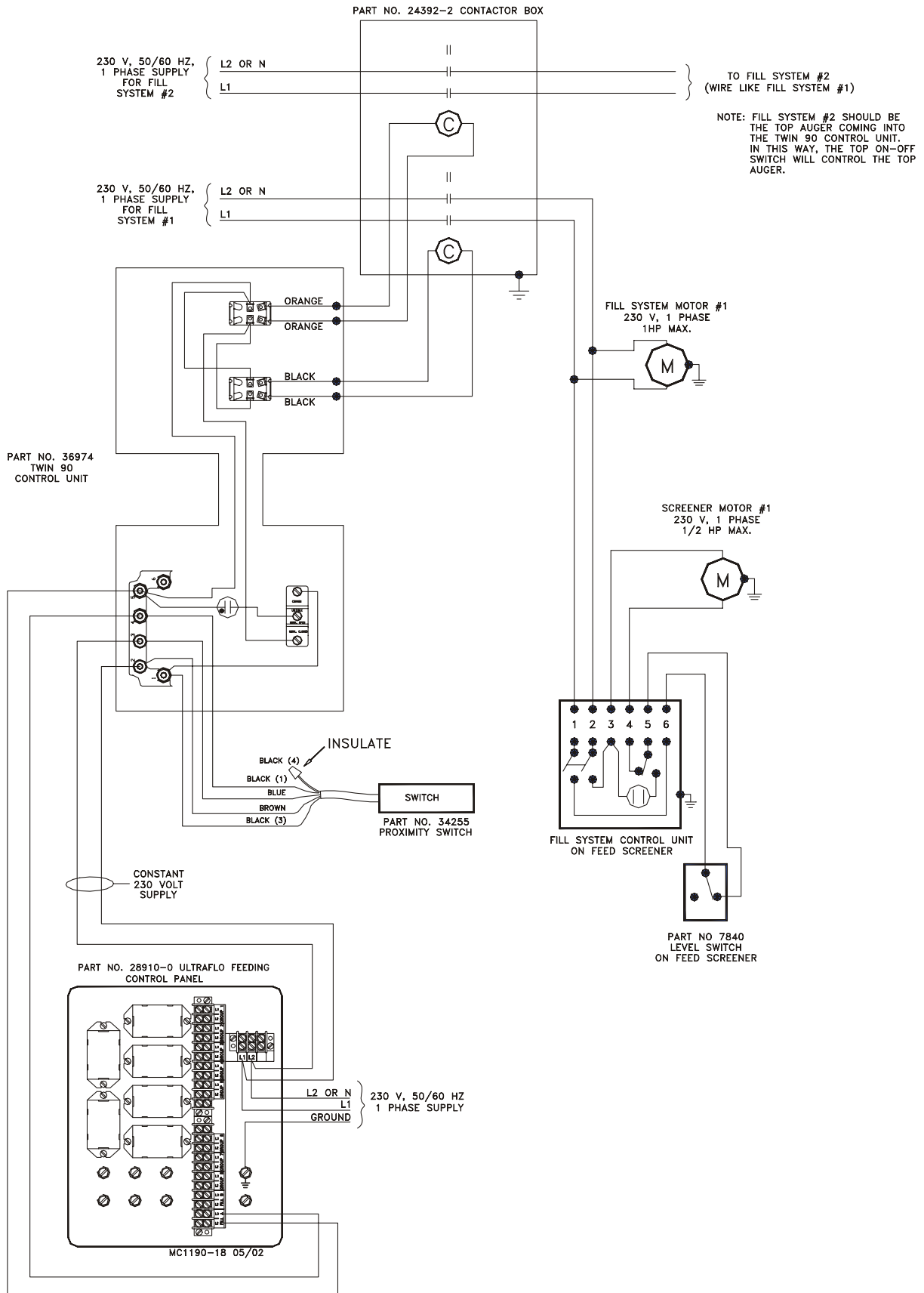

Model 90 Twin Control Unit w/ Dual Screener (1-Phase, with Motor Starters)

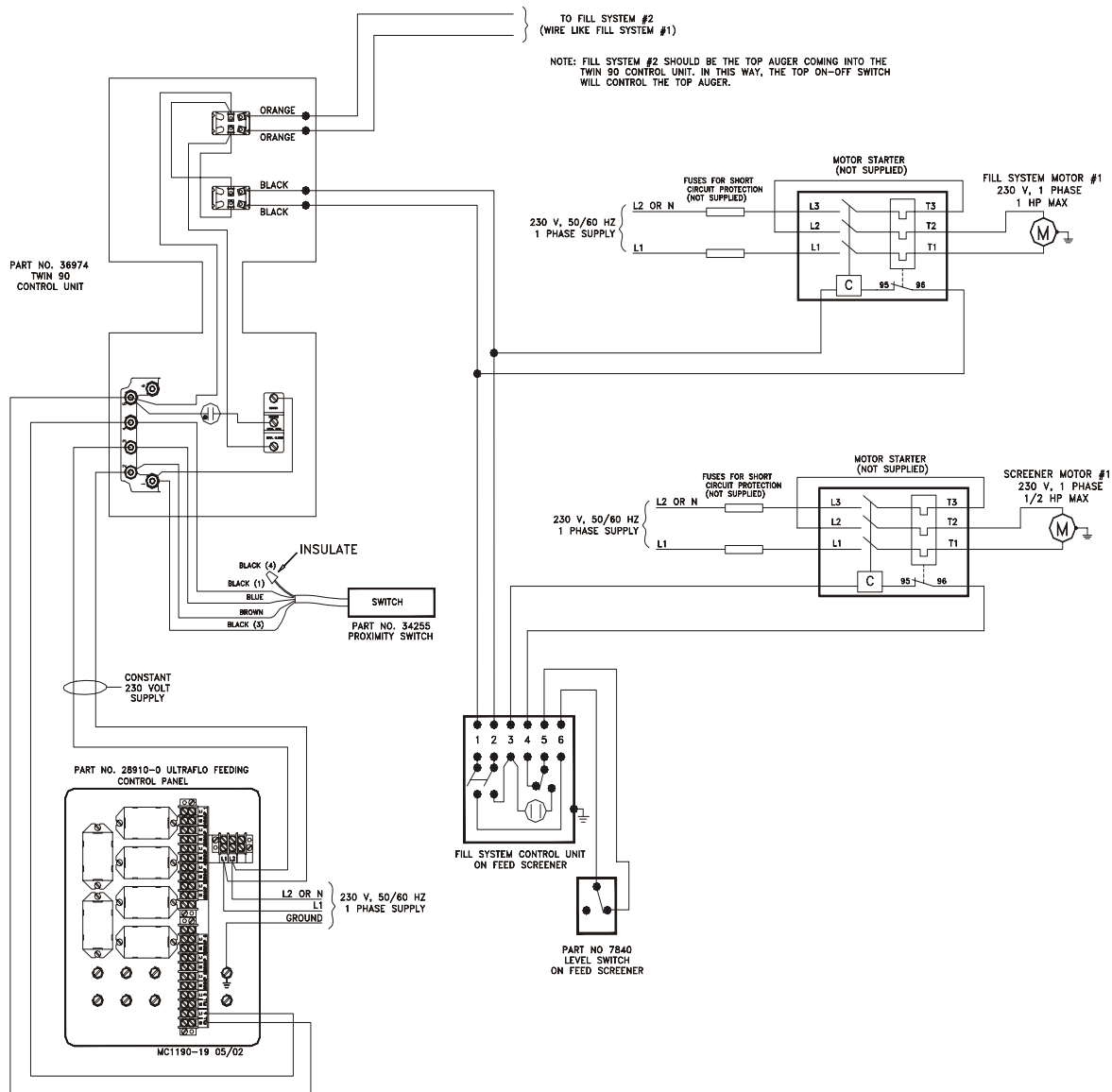

Model 90 Twin Control Unit with Dual Screener (3-Phase, with Motor Starters)

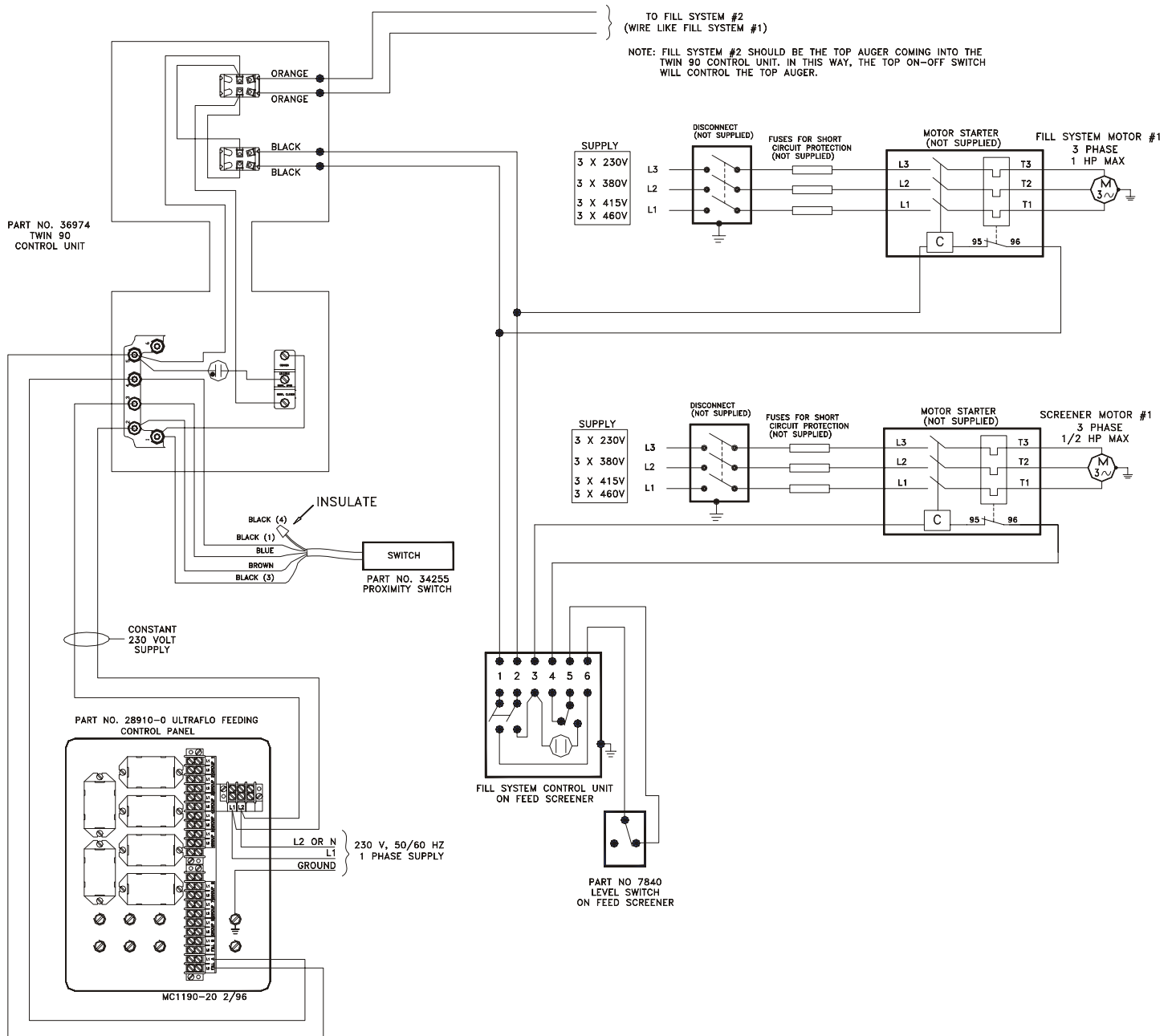

Model 90 Twin Control Unit with Twin Screeners

(1-Phase, without Motor Starters)

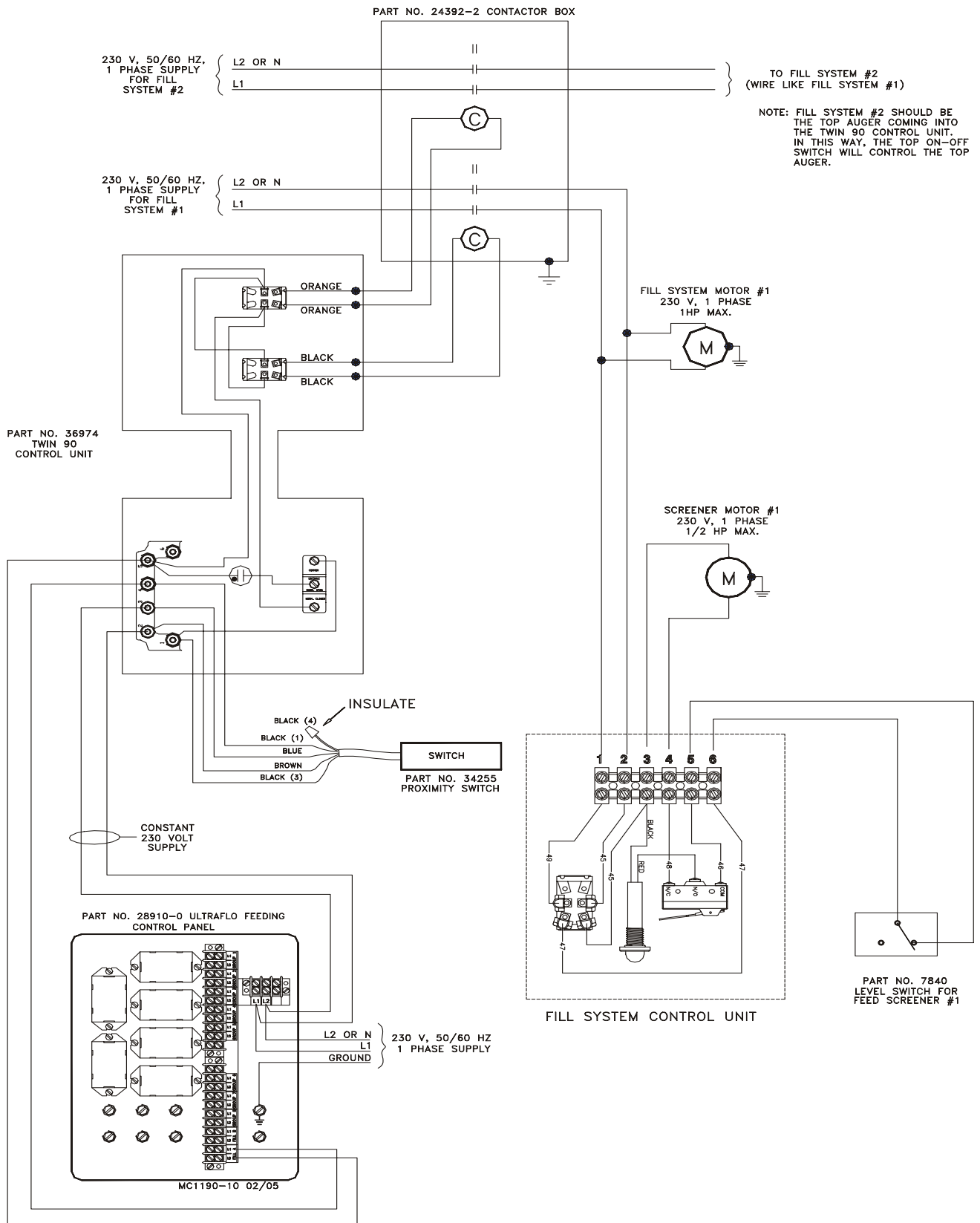

Model 90 Twin Control Unit with Twin Screeners (1-Phase, with Motor Starters)

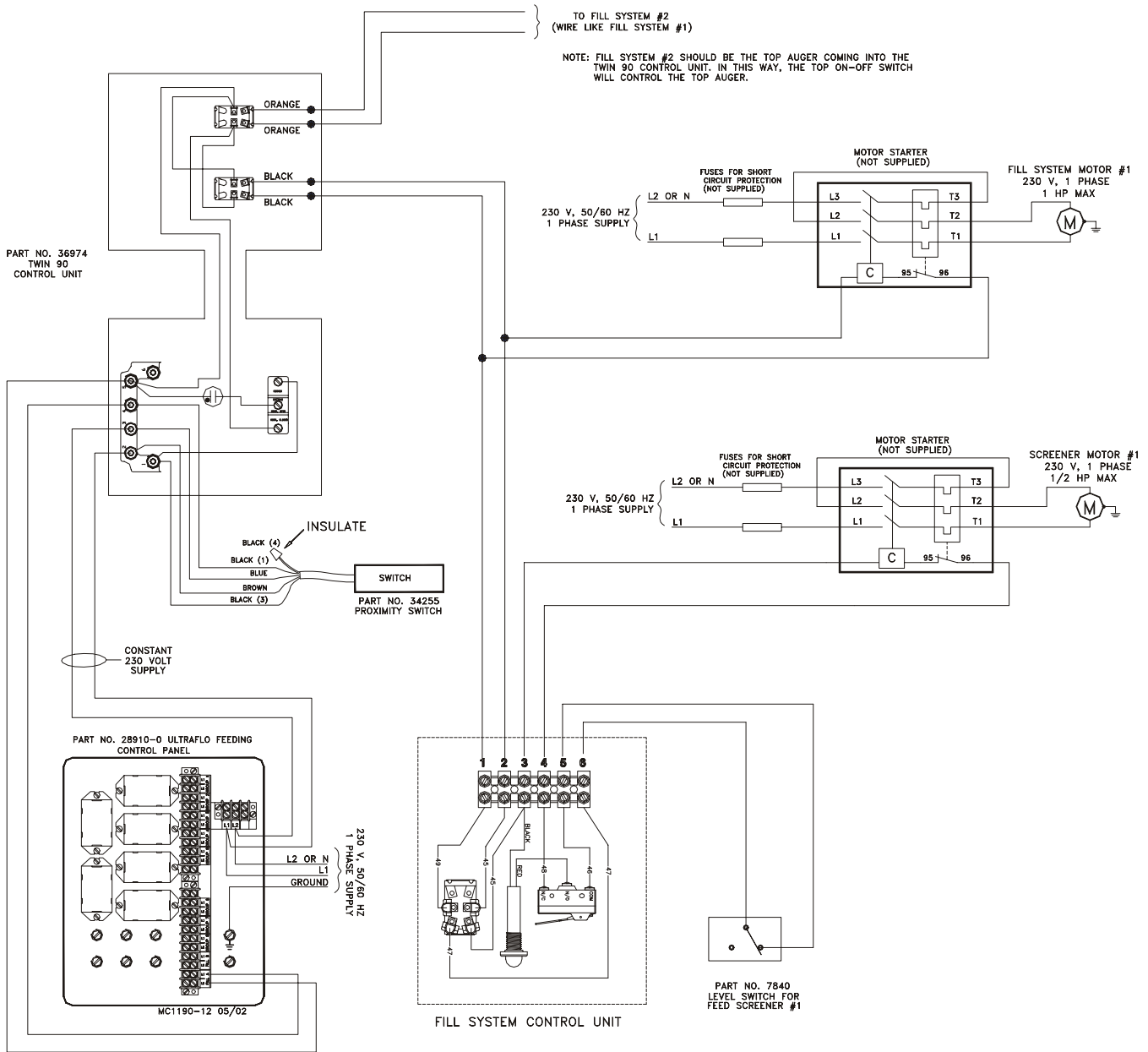

Model 90 Twin Control Unit with Twin Screeners (3-Phase, with Motor Starters)

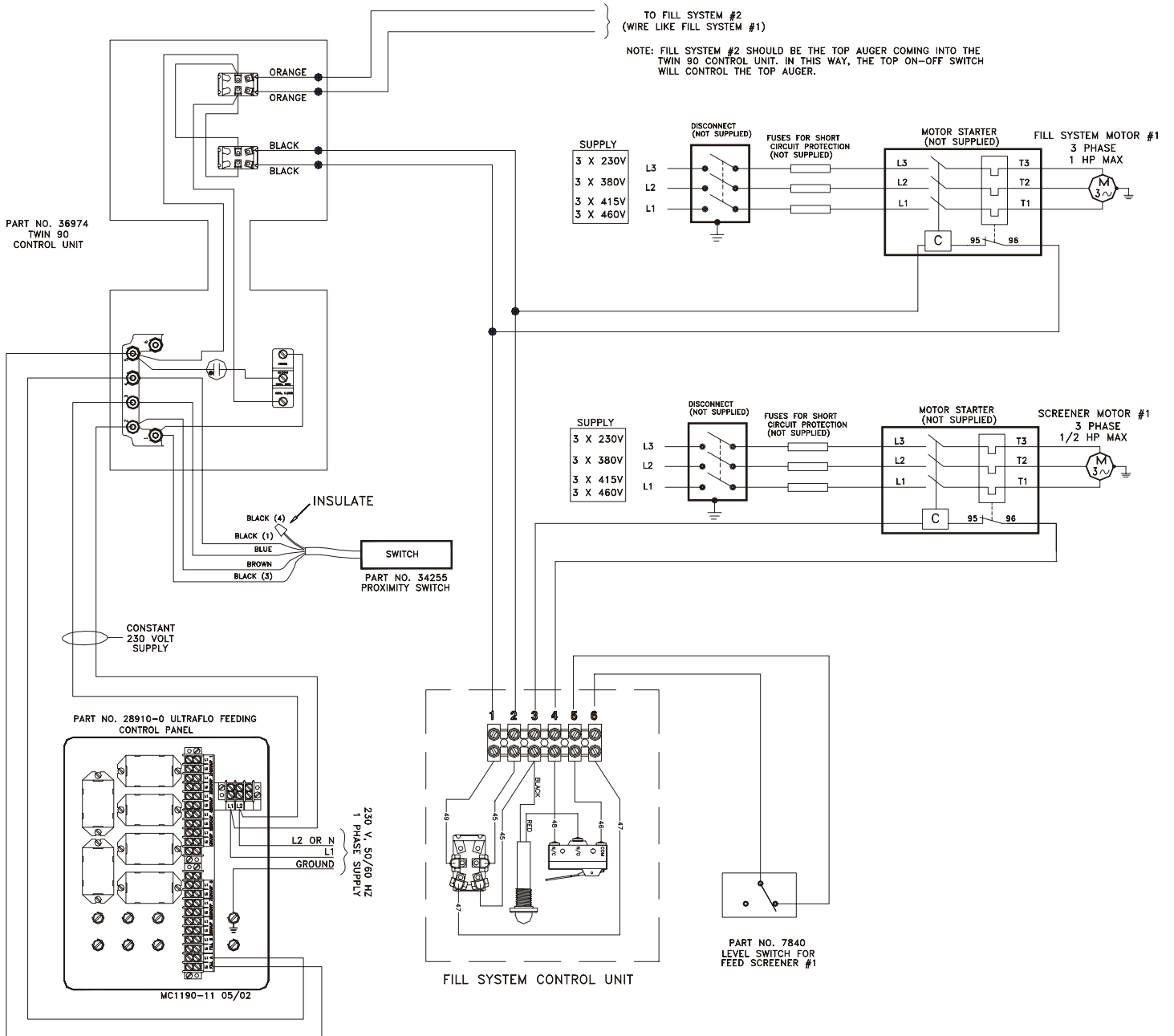

Model 90 Twin Control Assembly (Part No. 36974)

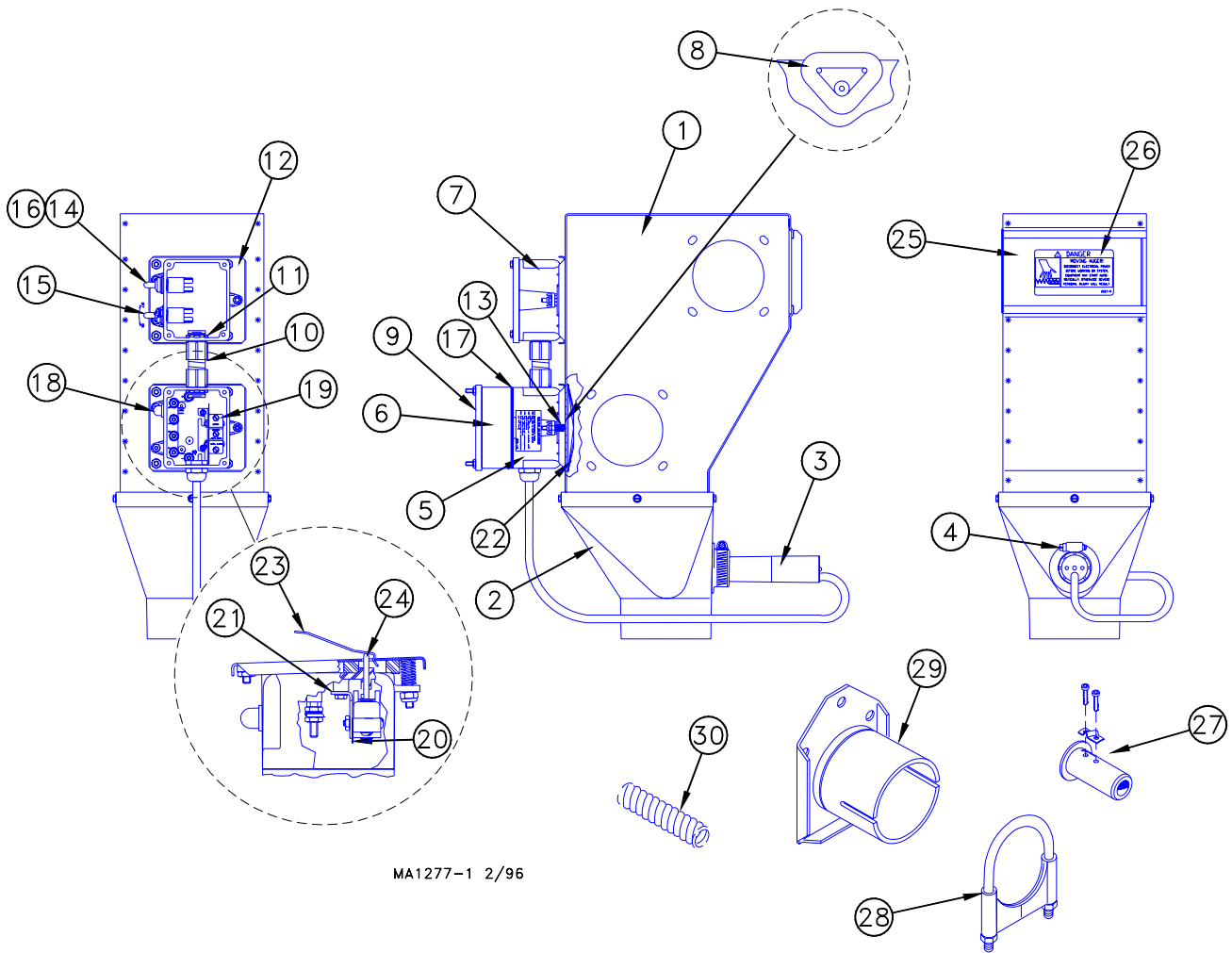

MA1277-1 2/96

<u>Item</u>	<u>Components</u>	<u>Part No.</u>	<u>Item</u>	<u>Components</u>	<u>Part No.</u>
1	Twin Control Body Weldment	36943	16	Toggle Switch Boot	13406
2	Weldment Drop	35788	17	Gasket	6777
3	Model 90 Twin Control Switch Assembly	36983	18	Pilot Light Assembly	7044
4	1-7/8" Adjustable Clamp	3527	19	SPDT Actuator Switch	46091
5	Terminal Box	36554	20	Switch Insulation	1907-5
6	Terminal Box	36946	21	Switch Bracket	46122
7	Terminal Box	36955	22	Diaphragm Assembly	7900
8	Gasket	6968-1	23	Paddle	7876
9	Switch Box Cover	6776	24	Pin	6775
10	Conduit Assembly	36554	25	Slide	5073
11	1/2" Conduit Lock Nut	3357	26	Danger Decal	2527-9
12	Switch Mounting Plate	7908	27	Model 90 Driver Assembly	6861
13	Compression Spring	6972	28	Tube Clamp Kit	6721
14	Toggle Switch	7767	29	Tube Anchor Weldment	5069
15	ON-OFF Dial	1740	30	1/2" Flexible Conduit	26982-10

***THANK-YOU for purchasing a Chore-Time
Model 90 Twin Control Unit.***

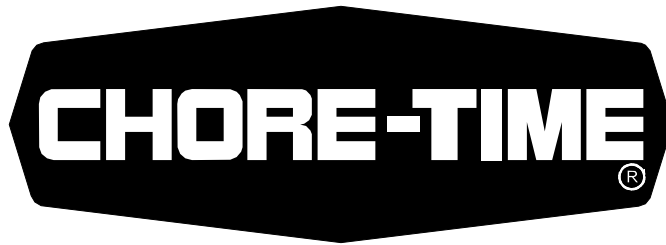

Made to work.
Built to last.

Contact your nearby Chore-Time distributor or representative for additional parts and information.
Chore-Time Equipment, A Division of CTB, Inc.
P.O. Box 2000, Milford, Indiana 46542-2000 U.S.A.
Phone: 574-658-4101

Printed in the U.S.A.