

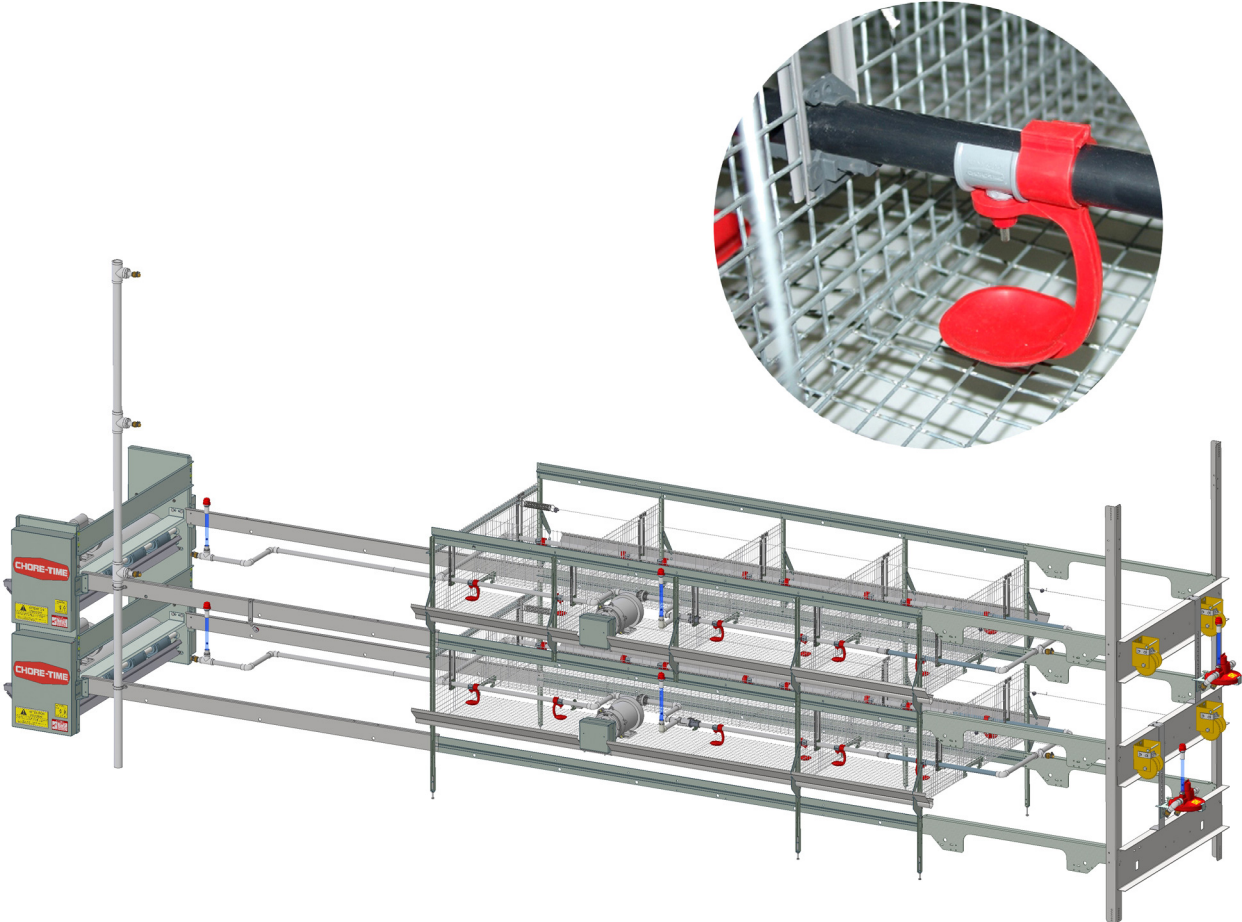

Modular Manure Belt Brood Grow Watering

Operation and Instruction Manual

Operation and Instruction Manual



Contents

Topic	Page
Chore-Time Limited Warranty	4
About This Manual	5
Safety Information	5
Safety Instructions	6
Follow Safety Instructions	6
Decal Descriptions	6
DANGER: Moving Auger	6
DANGER: Electrical Hazard	6
CAUTION:	6
General	6
Support Information	6
Introduction	7
Planning	7
Tools Required	7
Installation	8
Proper use of PVC Cement	8
Drain and Overflow Pipe Assembly	8
End Line Stand Tube Assembly	9
Mid Line Stand Tube Assembly	9
Winching Installation	10
Inlet Winch and Cable Installation	10
Hard Wire Installation	11
Anti-Twist Indicator Installation	13
EdgeGaurd/Wire Guides	14
Water Line Installation	15
Pipe Assembly and Installation	15
Catch Cup Installation	16
Nylon Cord Installation	17
Supply Line (Regulator End) Assembly	18
Regulator Support Assembly	18
Attaching Regulator Adjustment Bracket	18
Plumbing (Regulator End)	19
Mid-Line Assembly	21
By-Pass	21
End Line (Flush End) Assembly	22
Nylon Cords	24
Main Line Cords	24
End Line Cords	25
Filter Control Panel Installation	26
Flushable Filter Control Panel Installation	27
Water Meter Installation	28
Badger® Water Meter Installation	28
Wiring	28
Water Meter Start Up	29
Parts Listing	30
Suspension Components	30

Contents - continued

Topic	Page
.....	31
Water Line Parts	32
Water Conditioning Equipment.....	35
Filter Control Panel with Step Regulator	36
Flush able Filter Control Panel (36802-1 and 36802-2)	37
Pulse Water Meter (54579)	38
Slope Compensator (54035)	38
Mid Line Body Assembly /Motor Bypass (49607)	39
Regulator Assembly Manual (55476-4) and PDS (55476-5) Adjust).....	40
4 Station PDS™ Control 52430-4 and	42
8 Station PDS™ Control 52430-8	42
.....	43
PDS™ Control (part no.'s: 54373-XX) (International part no.'s: 54373-XXIN)	44
Stand Tube Assembly	46
Misc. Components List	46
Drain/Overflow Assembly Parts List	47

Chore-Time Limited Warranty

Chore-Time Group, a division of CTB, Inc. (“Chore-Time”) warrants the new CHORE-TIME Turbo Fans[®] manufactured by Chore-Time to be free from defects in material or workmanship under normal usage and conditions, for One (1) year from the date of installation by the original purchaser (“Warranty”). Chore-Time provides for an extension of the aforementioned Warranty period (“Extended Warranty Period”) with respect to certain Product parts (“Component Part”) as set forth in the table below. If such a defect is determined by Chore-Time to exist within the applicable period, Chore-Time will, at its option, (a) repair the Product or Component Part free of charge, F.O.B. the factory of manufacture or (b) replace the Product or Component Part free of charge, F.O.B. the factory of manufacture. This Warranty is not transferable, and applies only to the original purchaser of the Product.

Component Part	Extended Warranty Period
RXL Fan (except motors and bearings)	Three (3) Years
TURBO [®] Fan (except motors and bearings)	Three (3) Years
TURBO [®] Fan fiberglass housing, polyethylene cone, and cast aluminum blade.	Lifetime of Product
TURBO [®] fan motor and bearings.	Two (2) Years
Chore-Time [®] Poultry Feeder Pan	Three (3) Years
Chore-Time [®] Rotating Centerless Augers (except where used in applications involving high moisture feed stuffs exceeding 17%)	Ten (10) Years
Chore-Time Steel Auger Tubes	Ten (10) Years
ULTRAFLO [®] Breeder Feeding System auger and feed trough.	Five (5) Years
ULTRAPAN [®] Feeding System augers.	Five (5) Years

CONDITIONS AND LIMITATIONS

THIS WARRANTY CONSTITUTES CHORE-TIME’S ENTIRE AND SOLE WARRANTY AND CHORE-TIME EXPRESSLY DISCLAIMS ANY AND ALL OTHER WARRANTIES, INCLUDING, BUT NOT LIMITED TO, EXPRESS AND IMPLIED WARRANTIES, INCLUDING, WIHTOUT LIMITATION, WARRANTIES AS TO MERCHANTABILITY OR FITNESS FOR PARTICULAR PURPOSES. CHORE-TIME shall not be liable for any direct, indirect, incidental, consequential or special damages which any purchaser may suffer or claim to suffer as a result of any defect in the Product. Consequential or Special Damages as used herein include, but are not limited to, lost or damaged products or goods, costs of transportation, lost sales, lost orders, lost income, increased overhead, labor and incidental costs, and operational inefficiencies. *Some jurisdictions prohibit limitations on implied warranties and/or the exclusion or limitation of such damages, so these limitations and exclusions may not apply to you. This warranty gives the original purchaser specific legal rights. You may also have other rights based upon your specific jurisdiction.*

Compliance with federal, state and local rules which apply to the location, installation and use of the Product are the responsibility of the original purchaser, and CHORE-TIME shall not be liable for any damages which may result from non-compliance with such rules.

The following circumstances shall render this Warranty void:

- Modifications made to the Product not specifically delineated in the Product manual.
- Product not installed and/or operated in accordance with the instructions published by the CHORE-TIME.
- All components of the Product are not original equipment supplied by CHORE-TIME.
- Product was not purchased from and/or installed by a CHORE-TIME authorized distributor or certified representative.
- Product experienced malfunction or failure resulting from misuse, abuse, mismanagement, negligence, alteration, accident, or lack of proper maintenance, or from lightning strikes, electrical power surges or interruption of electricity.
- Product experienced corrosion, material deterioration and/or equipment malfunction caused by or consistent with the application of chemicals, minerals, sediments or other foreign elements.
- Product was used for any purpose other than for the care of poultry and livestock.

The Warranty and Extended Warranty may only be modified in writing by an officer of CHORE-TIME. CHORE-TIME shall have no obligation or responsibility for any representations or warranties made by or on behalf of any distributor, dealer, agent or certified representative.

Effective: **April, 2014**

Chore-Time Group, A division of CTB, Inc.
 PO Box 2000
 Milford, Indiana 46542-2000 USA
 Phone (574) 658-4101 Fax (877) 730-8825
 Internet: www.choretimepoultry.com
 E-mail: poultry@choretime.com

About This Manual

The intent of this manual is to help you in two ways. One is to follow step-by-step in the order of assembly of your product. The other way is for easy reference if you have questions in a particular area.

Important: Read ALL instructions carefully before starting construction.

Important: Pay particular attention to all SAFETY information.

- *Metric measurements are shown in millimeters and in brackets, unless otherwise specified. “” equals inches and “'” equals feet in English measurements.*

Examples:

1" [25.4]

4' [1 219]

- Optional equipment contains necessary instructions for assembly or operation.
- Very small numbers near an illustration (*i.e.*, 1257-48) are identification of the graphic, not a part number.

Note: The original, authoritative version of this manual is the English version produced by CTB, Inc. or any of its subsidiaries or divisions, (hereafter collectively referred to as "CTB"). Subsequent changes to any manual made by any third party have not been reviewed nor authenticated by CTB. Such changes may include, but are not limited to, translation into languages other than English, and additions to or deletions from the original content. CTB disclaims responsibility for any and all damages, injuries, warranty claims and/or any other claims associated with such changes, inasmuch as such changes result in content that is different from the authoritative CTB-published English version of the manual. For current product installation and operation information, please contact the customer service and/or technical service departments of the appropriate CTB subsidiary or division. Should you observe any questionable content in any manual, please notify CTB immediately in writing to: CTB Legal Department, P.O. Box 2000, Milford, IN 46542-2000 USA.

Safety Information

Caution, Warning and Danger Decals have been placed on the equipment to warn of potentially dangerous situations. Care should be taken to keep this information intact and easy to read at all times. Replace missing or damaged safety decals immediately.

Using the equipment for purposes other than specified in this manual may cause personal injury and/or damage to the equipment.

Safety–Alert Symbol



This is a safety–alert symbol. When you see this symbol on your equipment, be alert to the potential for personal injury. This equipment is designed to be installed and operated as safely as possible...however, hazards do exist.

Understanding Signal Words

Signal words are used in conjunction with the safety–alert symbol to identify the severity of the warning.



DANGER indicates an imminently hazardous situation which, if not avoided, **WILL** result in death or serious injury.



WARNING indicates a potentially hazardous situation which, if not avoided, **COULD** result in death or serious injury.



CAUTION indicates a hazardous situation which, if not avoided, **MAY** result in minor or moderate injury.

Safety Instructions

Follow Safety Instructions

Carefully read all safety messages in this manual and on your equipment safety signs. Follow recommended precautions and safe operating practices.

Keep safety signs in good condition. Replace missing or damaged safety signs.

Decal Descriptions

DANGER: Moving Auger

This decal is placed on the Panel Weldment.

Severe personal injury will result, if the electrical power is not disconnected, prior to servicing the equipment.

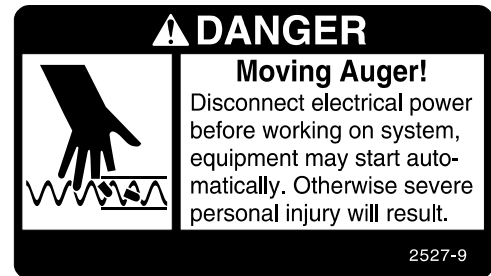

DANGER: Electrical Hazard

Disconnect electrical power before inspecting or servicing equipment unless maintenance instructions specifically state otherwise.

Ground all electrical equipment for safety.

All electrical wiring must be done by a qualified electrician in accordance with local and national electric codes.

Ground all non-current carrying metal parts to guard against electrical shock.

With the exception of motor overload protection, electrical disconnects and over current protection are not supplied with the equipment.

CAUTION:

Use caution when working with the Auger—springing Auger may cause personal injury.

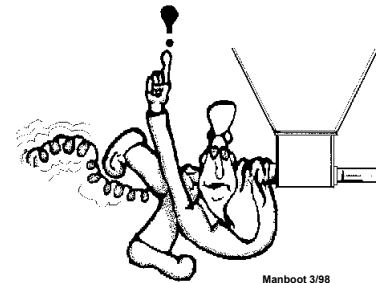
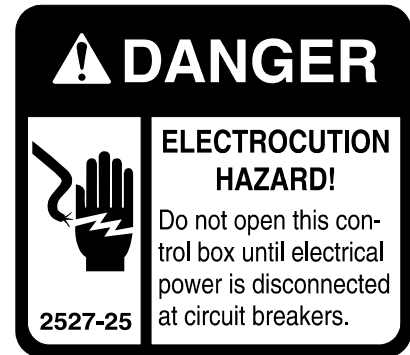

General

Support Information

The Chore-Time Nipple Watering System is designed to provide water to poultry. Using this equipment for any other purpose or in a way not within the operating recommendations specified in this manual will void the warranty and may cause personal injury.

This manual is designed to provide comprehensive planning and installation information. The Table of Contents provides a convenient overview of the information in this manual

Introduction

It is important to maintain good water quality. Good water quality maximizes performance of the equipment, minimizes maintenance and repair, and increases the life of the system. The water should be free of foreign particles.

Pump the well prior to hookup of the system to clear sand, mud, or debris. CHORE-TIME strongly recommends a water test by a reputable water treatment company in the area. Water treatment and/or extra filtration may be required, depending on the water test results.

CHORE-TIME recommends an incoming water pressure between 40 PSI (2.9kg/cm²) minimum and 125 PSI (8.8kg/cm²). A pressure of 45 psi [310.3 kPa] is best. It is recommended to use the step regulator for regulating the water pressure through the control panel at 25 psi [172.4 kPa] up to a maximum of 35 psi [241.4 kPa].

Incoming water supply should be at least a 1" [25 mm] diameter incoming line (preferably PVC) from a single well. If there are two or more supply wells, the supply line should be larger. Other factors such as, the distance from the well(s) to the equipment which require water could demand larger lines. For every 28" [711 mm] drop in height, water pressure increases one pound. Measure the operating pressure at the water line height.

Each pressure regulator is capable of supplying one tier (two lines) up to 600 feet (182.8 meters). Systems over 600 feet (182.8 meters) require two inlet assemblies per tier (one per line).

Planning

Chore-Time recommends taking time to lay out the sections of water pipe and other large components prior to beginning each installation step. Hardware, tools, and small components (valves, etc.) may be conveniently carried in a carpenter's apron.

There are two (2) sub-assemblies which need to be completed prior to the nipple water installation. Assembly instructions are included in this manual for the stand tube assembly and the overflow/drain pipe assembly.

Installation of Chore-Time Cage Watering System can be broken down into the following general steps:

- Assembly of the drain/overflow pipes.
- Installation of the water lines and accessories.
- Installation of the winch system.
- Installation of the regulator.
- Installation of the stand tube.
- Installation of the drain/overflow pipes.

Tools Required

Tools needed to install your nipple water system include:

- Regular Screwdriver
- Bolt cutters or Hack Saw
- Locking Pliers
- PVC Cleaning Solvent
- File
- Electric Drill and Drill Bits
- Saw top cut PVC tube
- De-Burring tool
- Screw-Hook Driver

Installation

Proper use of PVC Cement

Important! FOLLOW THE DIRECTIONS ON THE CONTAINER OF PVC CEMENT FOR SAFE HANDLING AND BEST RESULTS.

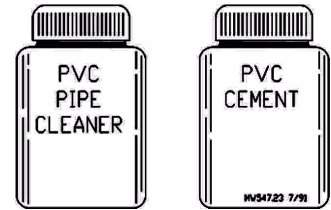

Figure 1. PVC Cement (Part No. 6303-4)

1. Be sure pipe is cut off squarely. USE PIPE CUTTERS ONLY. Failure to use pipe cutters voids the warranty.
2. Remove dirt and burrs from outside and inside of the pipe.
3. Dry fit all parts before cementing. Pipe should be fit into fittings without applying excess force.
4. Surfaces to be joined should be clean--free from dirt, oil, and grease. Use PVC Pipe Cleaner, as needed.
5. Apply cement to both surfaces to be joined. Apply cement sparingly, but evenly over the entire surface, leave no bare spots. Use a PVC cement containing PVC resin (gray in color).

Drain and Overflow Pipe Assembly

The assembly of the drain/overflow pipes will need to be done prior to installing the nipple drinking system.

Use teflon tape on threads as required. Use PVC glue (see PVC cement directions) on slip connections.

1. Install the Tee (38618), Bushing Reducer (36808), and 3/4 Male Adapter (25098) (See Figure 2.)
2. Cut the 1.5 x 10' PVC pipe (38296) into required lengths.
 - Length of pipe from floor to tier 1 is 44" [1.12 m].
 - Length of pipe between tiers is 20.5"[50.1 cm].
 - Length of pipe between tiers with walkways is 32.5" [82.6 cm].
3. Deburr the PVC piping.
4. Attach the PVC pipe segments into the PVC tee assemblies using a slip connection. (See Figure 2.)
 - Make sure you align the tees so that the top outlets are all facing the same direction **as shown**.
5. Make one complete drain/overflow pipe assembly for one side of every row of the modular manure belt. These assemblies will be used in the installation of the drain/overflow pipe systems.

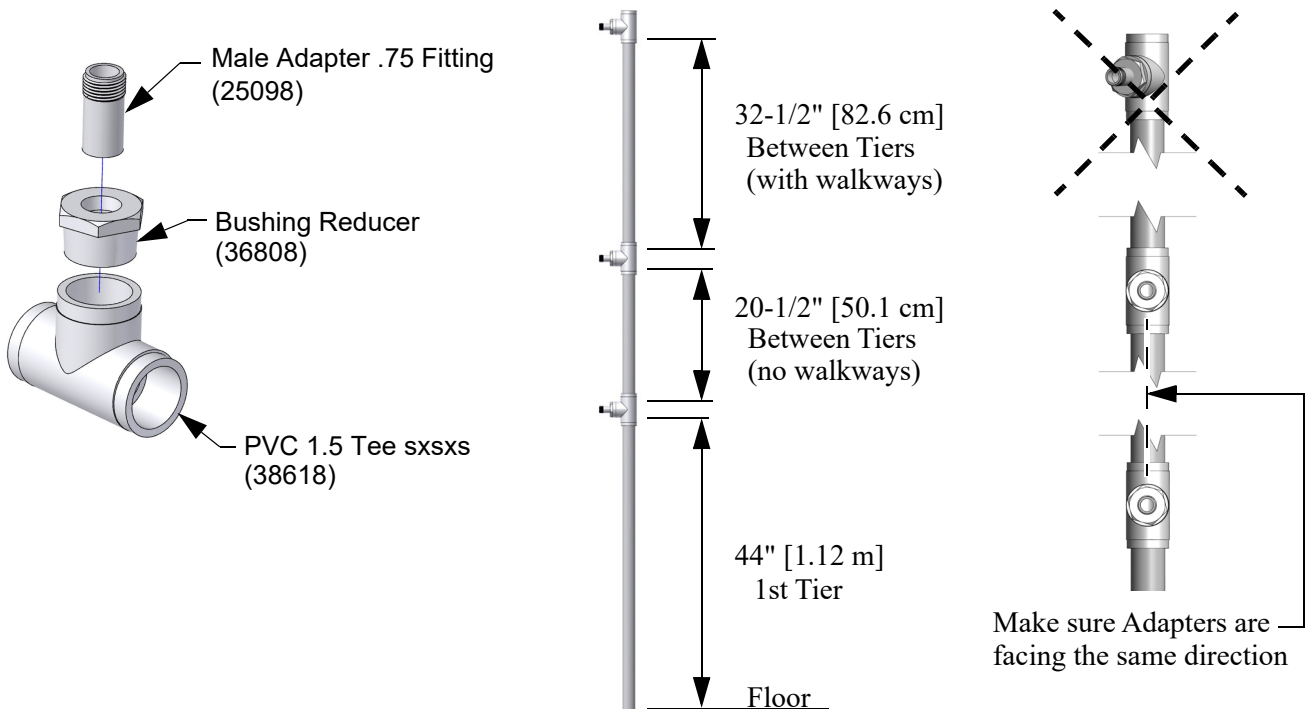

Figure 2. Drain and Overflow Assembly

End Line Stand Tube Assembly

The assembly of the stand tubes will need to be done prior to installing the nipple drinking system.

- Use teflon tape on threads as required.
- Use PVC Glue on Slip Fittings.

1. Install a .75 Male Adapt Fitting (25098), to the inside of a .75" PVC sxsxtx tee (8061) as shown in Figure 3 below.
2. Attach the Stand Tube (54517-X) to the .75 PVC Tee (8061).
3. Make one Complete End Line Stand Tube Assembly per tier of the Modular Manure Belt.

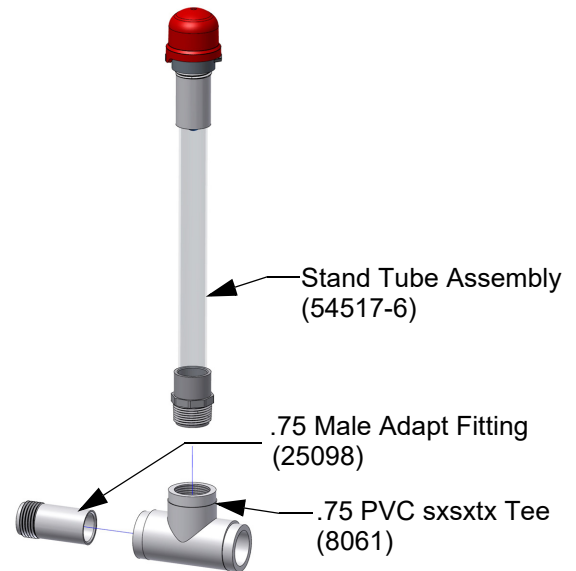

Figure 3. End Line Stand Tube Assembly

Mid Line Stand Tube Assembly

The assembly of the stand tubes will need to be done prior to installing the nipple drinking system.

- Use teflon tape on threads as required.

4. Install a PVC SXT Ell (7558) onto a Stand Tube (54517-X) as shown.
5. Make one Complete Mid Line Stand Tube Assembly per each side of each tier of the Modular Manure Belt. **For example:** A three tier Manure Belt will require six Stand Tube Assemblies.

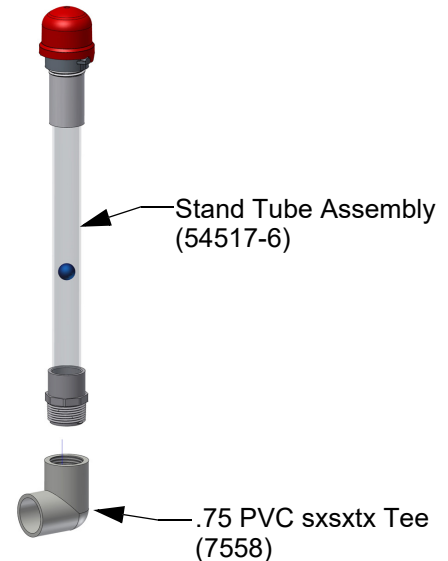
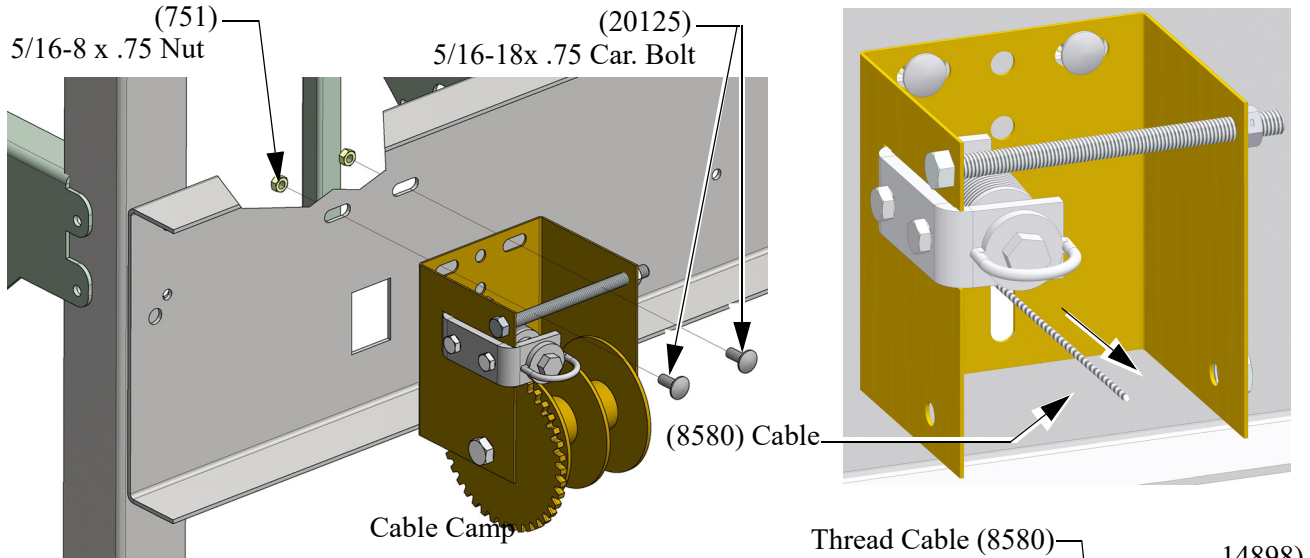

Figure 4. Mid Line Stand Tube Assembly

Winching Installation

Inlet Winch and Cable Installation

1. Bolt the Winch (46058) to the Idler Cross Brace Rail using two 5/16-18 x .75 Carriage Bolts (20125) and 5/16-18 Hex Nuts (751) **(As Shown in Figure 5.)**
2. Feed the end of the Cable (8580) through the Idler Cross Brace and wrap it around the Winch Drum clockwise. Route the Cable through the hole in the Winch and Secure with a Cable Clamp (14898) as shown.
3. Stretch out enough Cable to reach within 6" [15.2 cm] of 1st Partition as shown.
4. Install two Winches per Tier.



Thread Cable (8580)
Through the Cross Brace
and ob round hole

14898

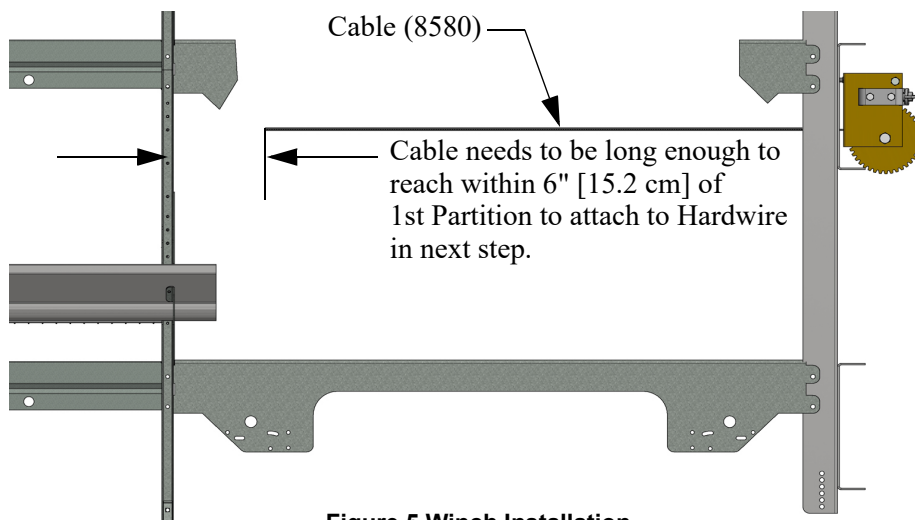
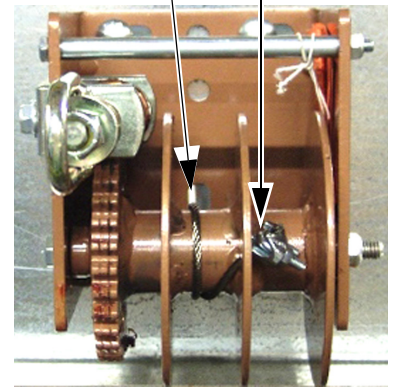

Figure 5. Winch Installation

Hard Wire Installation

Winch End

1. Install Hardwire (46059) starting at the Winch end by feeding it through the Partitions in the location shown below in **(Figure 6.)**
2. Bend up the end of the Hard Wire as shown.
3. With a minimum of 8" past the 1st partition as shown, Fasten the Hard Wire to the Cable with a Cable Clamp (14898).
4. Install Hardwire two per tier.

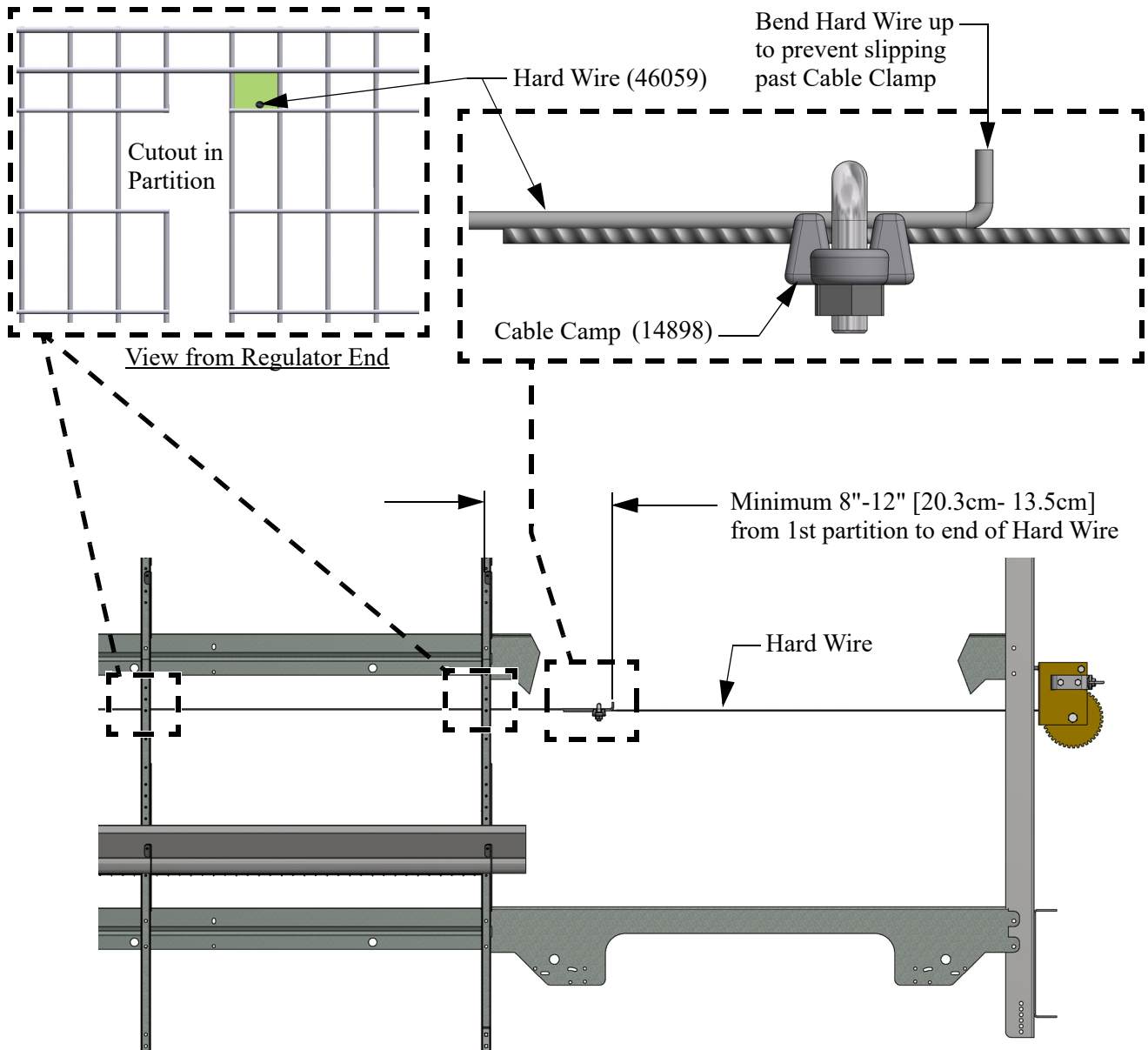

Figure 6. Hard Wire Installation

Opposite Winch End

1. Attach a Watering Spring Brace (50578-X) to the Leg of the Last Partition as shown with (3037) Screws.
2. Install a (22911) Eyebolt with a (751) 1/4-20 Nut as shown.
3. Attach a (30082) Spring.
4. With the Hardwire pulled tight cut it off approximately 3" [7.6 cm] past the end of the Spring.
5. Pull the Hardwire tight and attach to the Spring with a (14898) Cable Clamp.
6. Install Springs at each Hardwire (two per Tier).

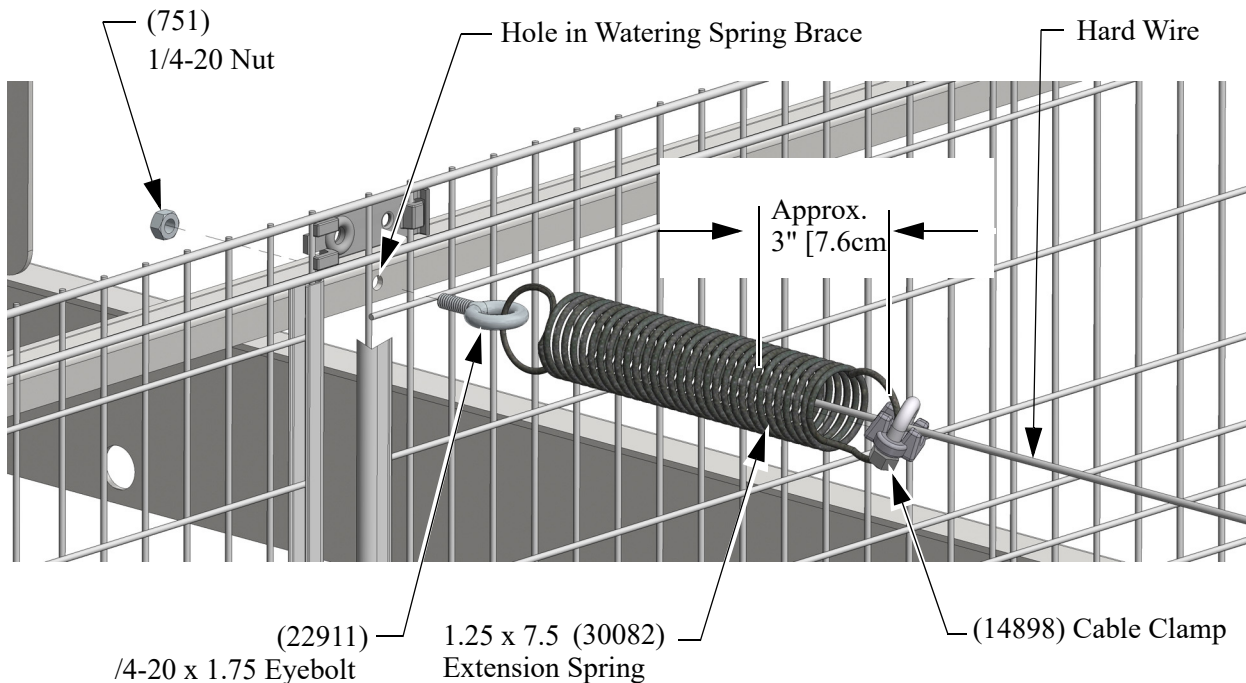
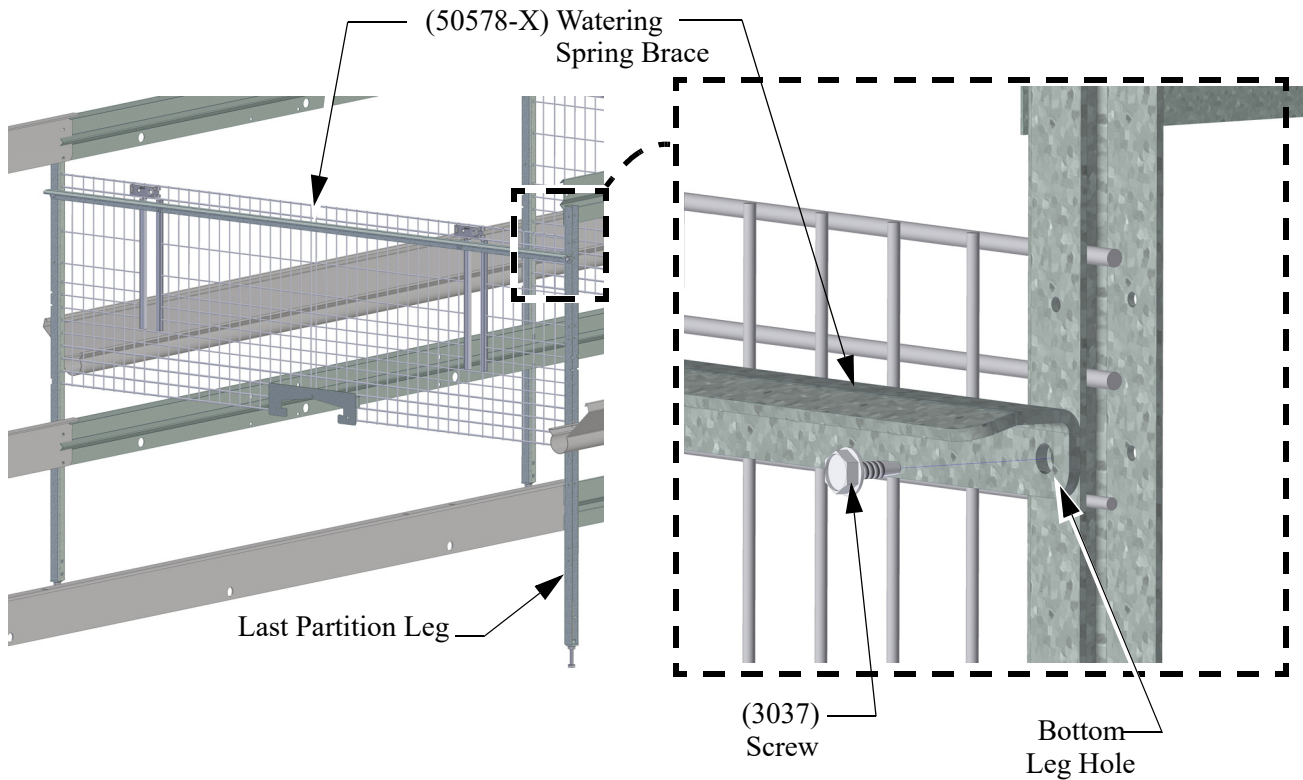

Figure 7.Hard Wire Installation (Opposite Winch)

Anti-Twist Indicator Installation

The Anti-Twist Indicator should be installed between the 1st two partitions, two per tier

1. Install the (50557) Anti-Twist and Indicator Guide in the location shown below in **(Figure 8.)** using (2046) Bolts, (E2700) Washers and (2145) 1/4-20 Flange Nuts.
2. Insert a (48957) Anti-Twist Indicator Arm into the Indicator Guide, Slide it all the way to the end of the slot opposite the Winch end (Watering Down position).
3. Secure the Anti-Twist Arm to the Hardwire with two (50557) Cable Clamps and finally slide a (41857) Set Collar on and torque Set Screw down. **(See Figure 8.)**

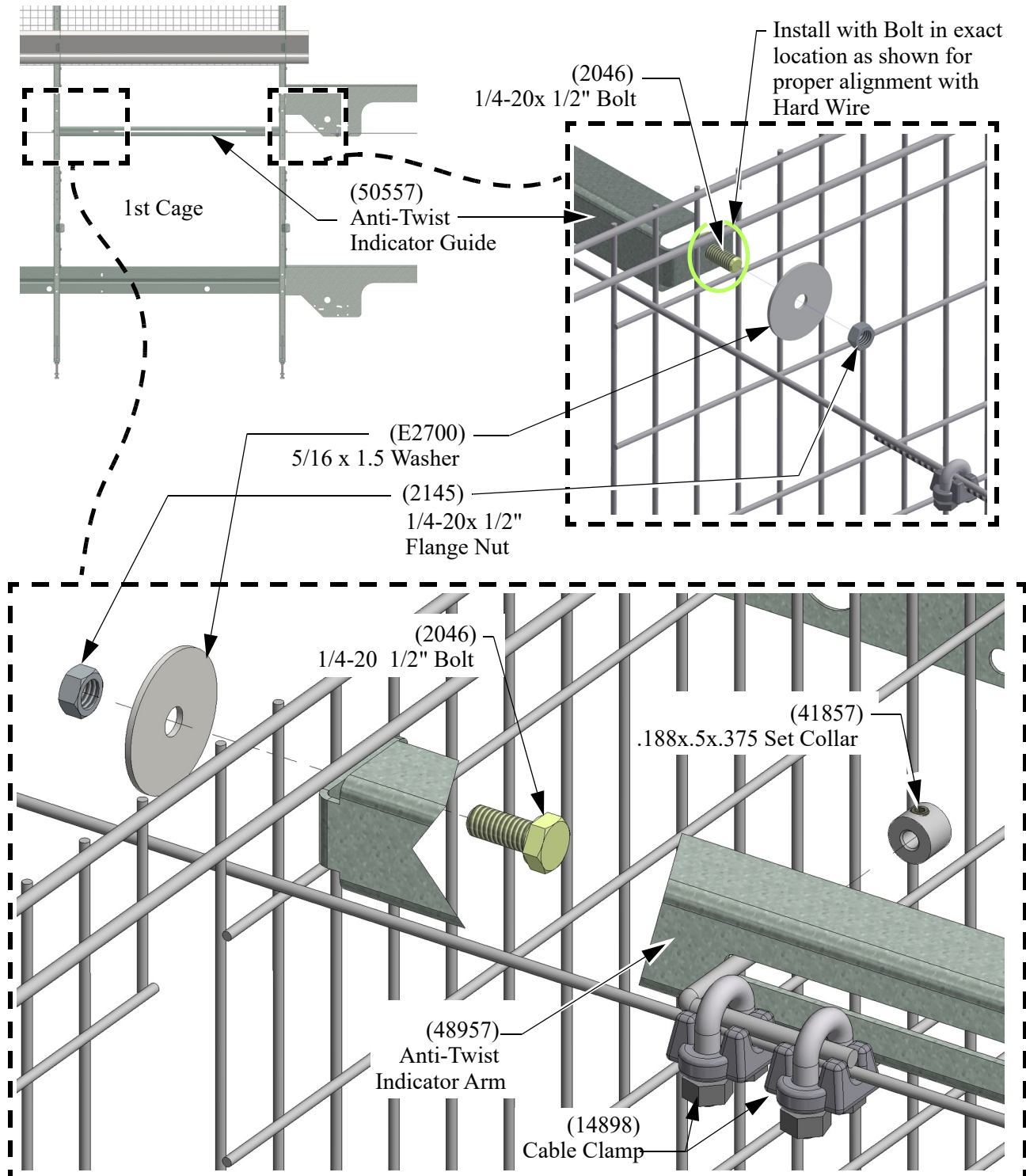

Figure 8. Anti-Twist Indicator Installation

EdgeGaurd/Wire Guides

1. Install edge guard (14647-1) at the Water Pipe openings at each partition only on one side (the side opposite the Water Pipe Cut-out) as shown (See Figure 9).
2. Install Wire Guides (51678) on each partition as shown. Make sure the Wire Guides are installed on the side of the partition opposite the Manure Drive. The big hole is centered over the slot as shown. (See Figure 9). Make sure the Edge Guards are pushed on all the way.

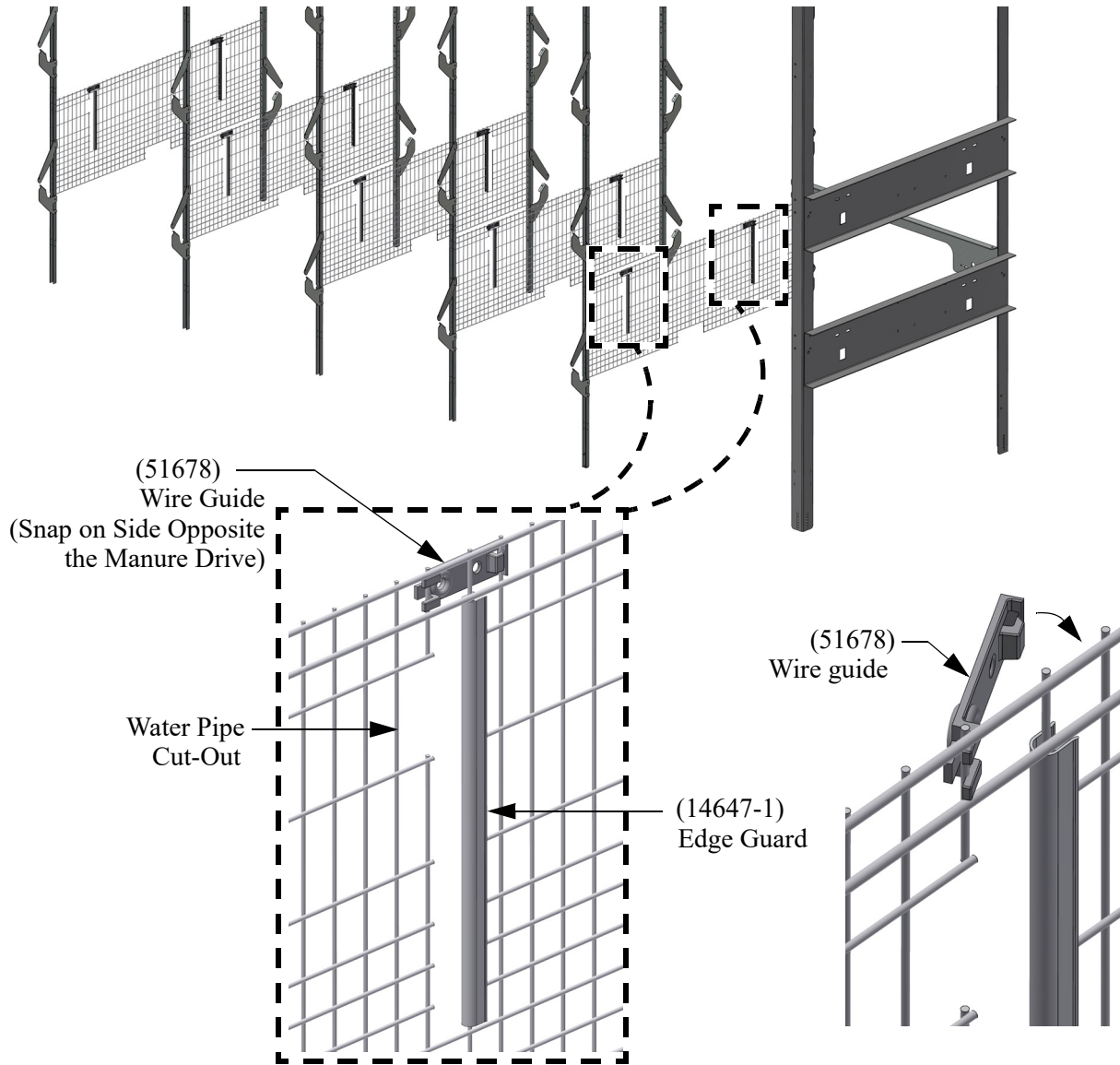

Figure 9.Edge Guard /Wire Guides Installation

Water Line Installation

Pipe Assembly and Installation

The Chore-Time STEADI-FLOW® nipple waterer pipe is available with nipples 2 per cage (50992) or 3 nipples per cage (51001) at 10' [3 m].

1. Attach a short End section (51796) to a long section of Nipple Pipe. The Nipples all must point the same direction. Install o-rings, part no. 29118, into bell end of the nipple pipes and lubricate before putting the pipes together. (See Figure 10.)

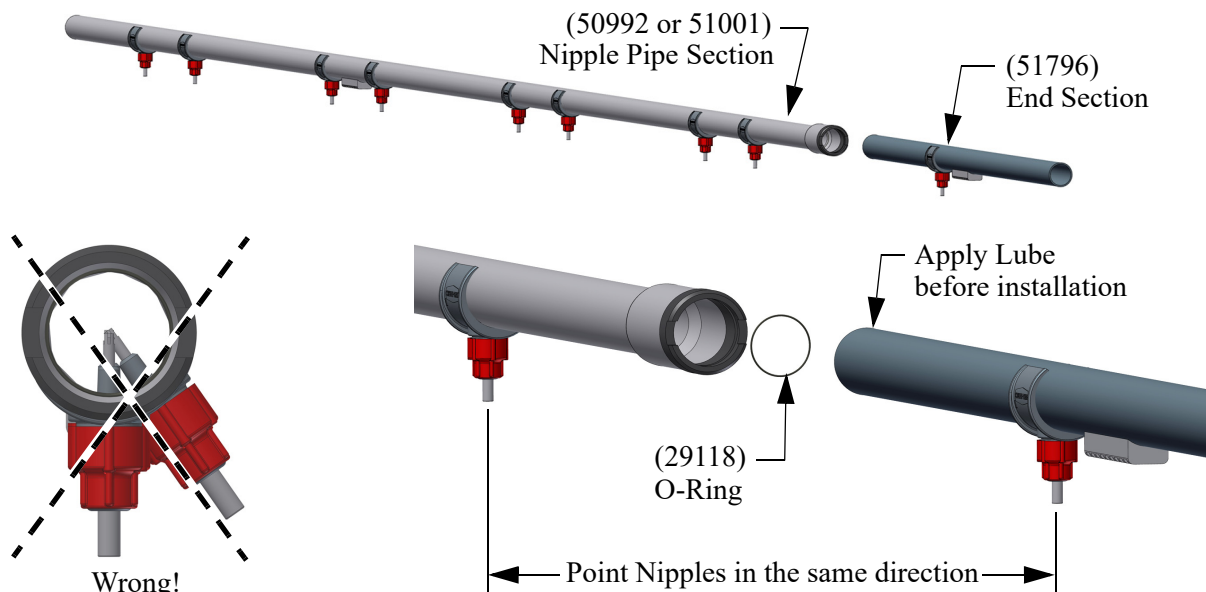

Figure 10. Water Pipe Assembly

2. Thread the Nipple Pipe through the openings cut in the cage partitions until the Locator Block of the Short End Section (51796) is lined up with the center of the 1st Cage Partition. (See Figure 11.)

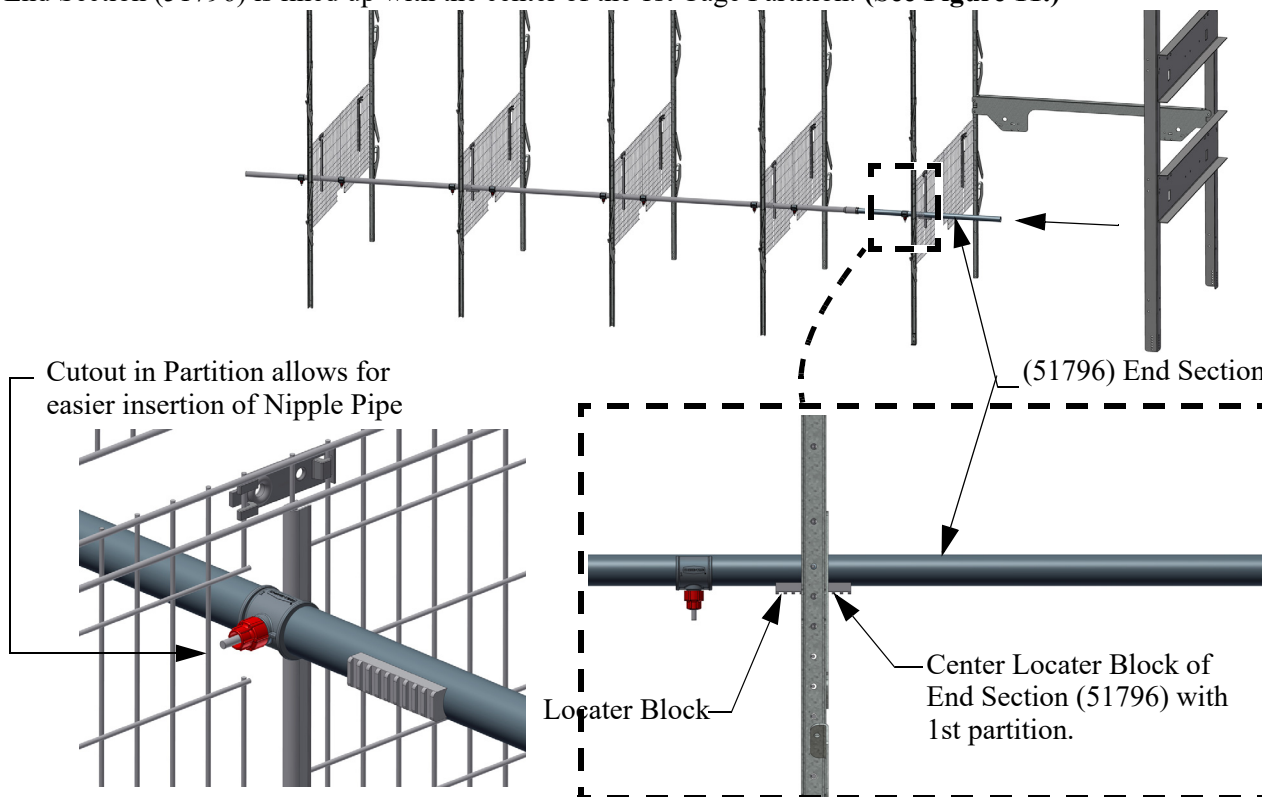

Figure 11. Water Line Installation

3. After the Nipple Pipe is in place, install Edge Guard on the other side of the Water Pipe opening at each partition.
4. Install a Locator Hanger (43716) at each Locator Block location as shown in (Figure 12.)

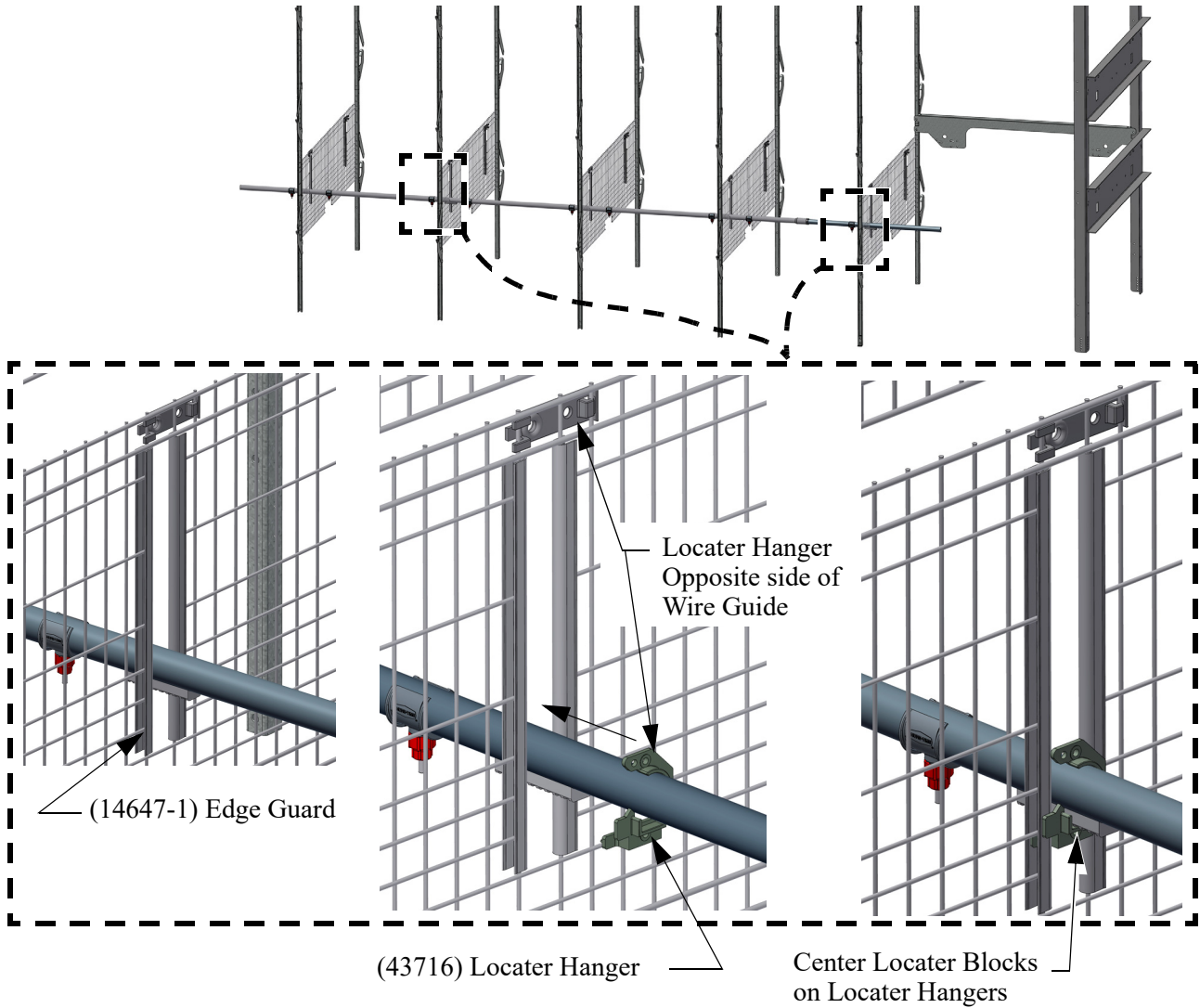

Figure 12.Edge Guard/Locator Block installation

Catch Cup Installation

1. Attach the Catch Cups (50250) by snapping them over the Nipples. Catch Cups face the Partitions as shown (Figure 13.)

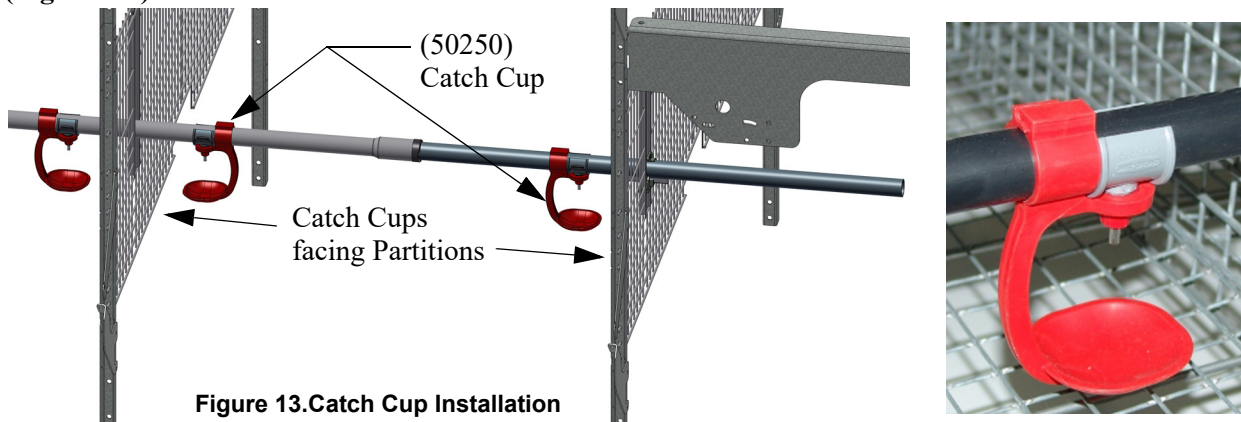

Figure 13.Catch Cup Installation

Nylon Cord Installation

Install 34" Nylon Cords at each Partition.

1. Tie a Knot at the end of a 34" Cord (14648-7) and Route it through the Wire Guide, around the Nipple Water Pipe and back through the Large Hole in the Wire Guide. **(Figure 14.)**

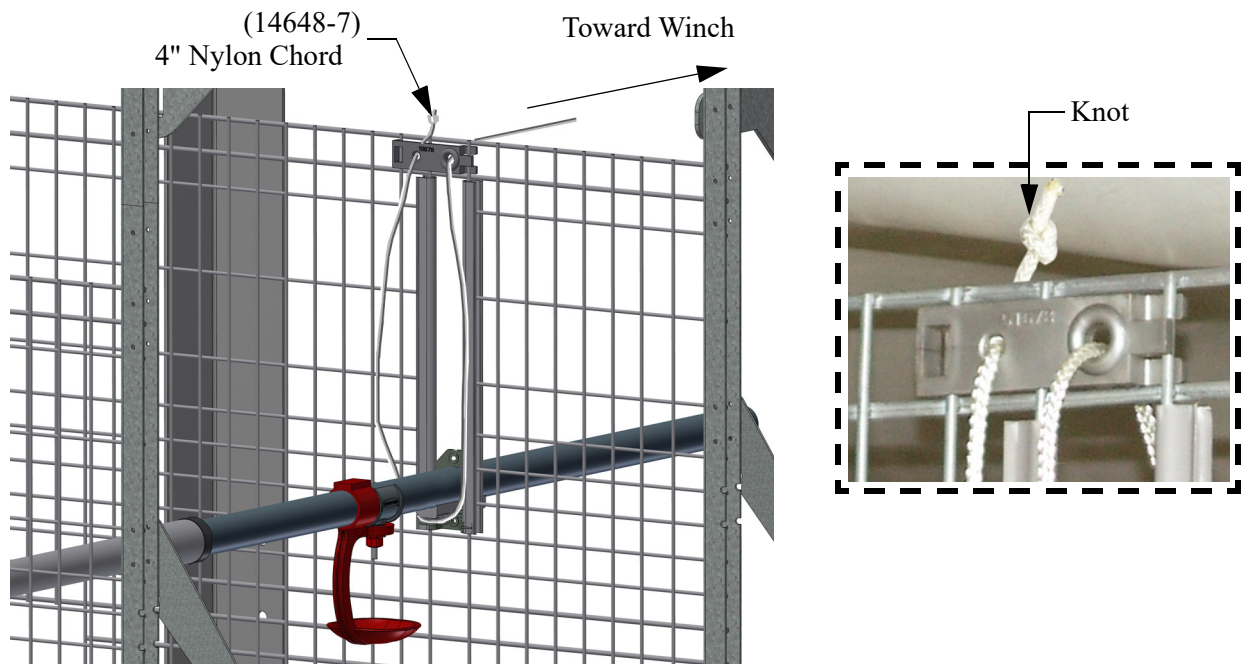

Figure 14.34" Nylon Cord Installation

Supply Line (Regulator End) Assembly

Regulator Support Assembly

1. Install (2029) Bolts and (46460) Flange Nuts in the (54424) Regulator Supports (As Shown in Figure 15.).
2. Install (1269) Locknuts leaving a .125" [3.2 mm] gap as shown.

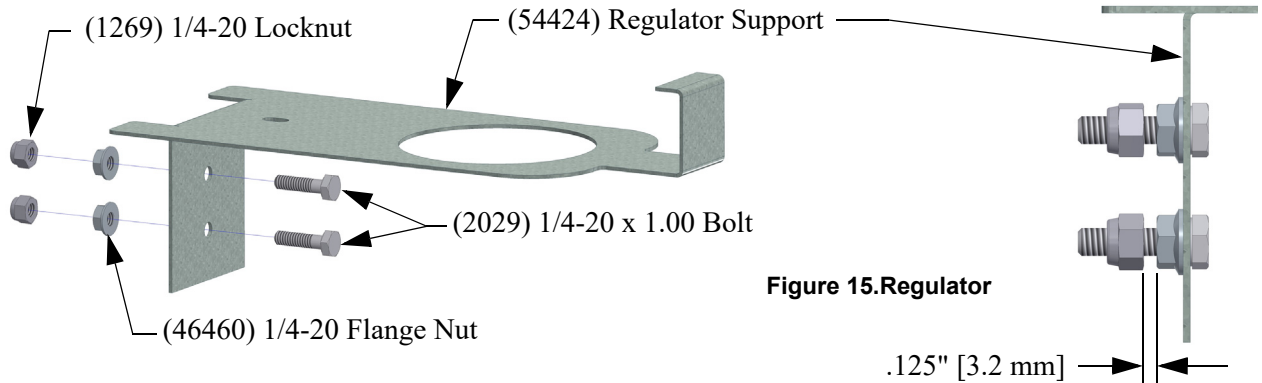

Figure 15.Regulator

1. Snap the Regulator (52280-0) onto the Regulator Support as shown.
2. Attach a (53862) Regulator Clamp with a (7551-1) Car. Bolt and (46460) 1/4-20 Flange Nut to hold Regulator in place as shown.

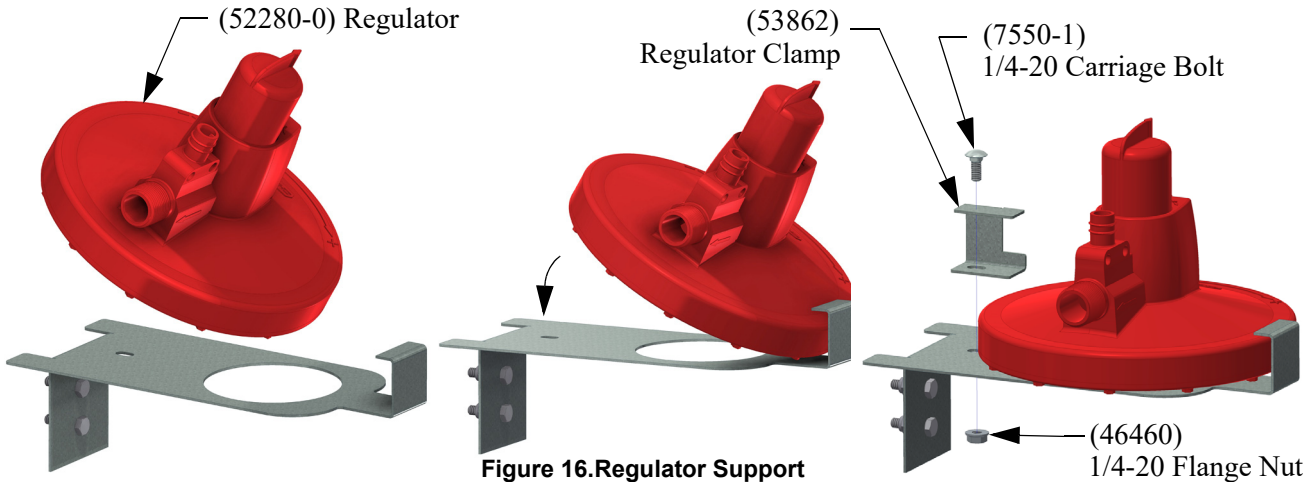

Figure 16.Regulator Support

Attaching Regulator Adjustment Bracket

1. Attach a Stand Tube to the Regulator with a (7187) Hose Clamp.
2. Insert the Bolts into the desired Keyhole Slots in the Regulator Adjustment Bracket and push down to lock in place as shown. Loosen the Locknuts if necessary.

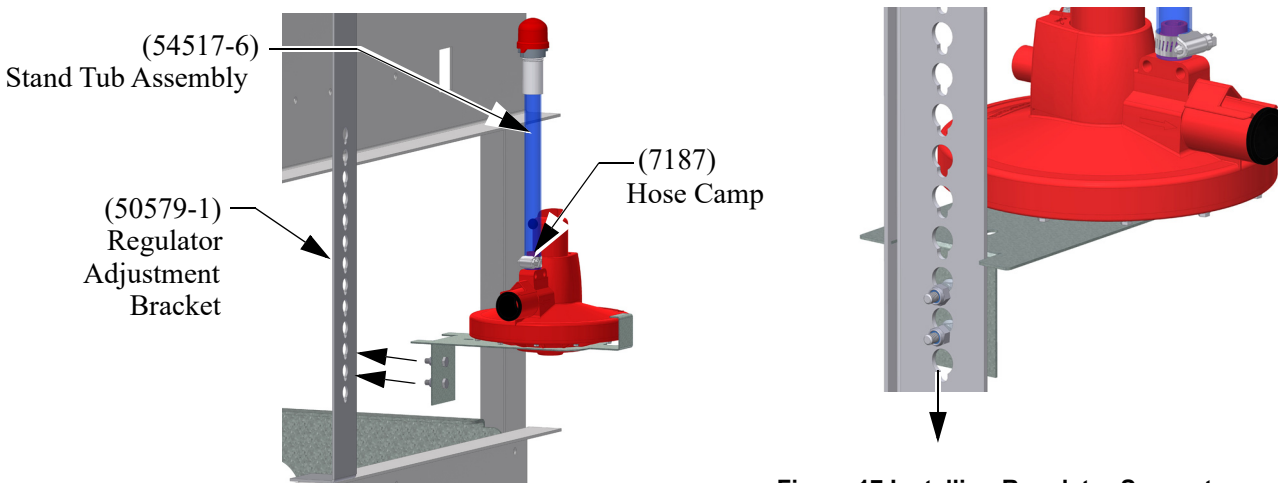

Figure 17.Installing Regulator Support

1. Location of the Regulator can vary. Approximate dimensions are shown below for standard installation.
2. Attach a (50579-1) Regulator Adjustment Bracket to the Idler Back with two (3037) Screws as shown.

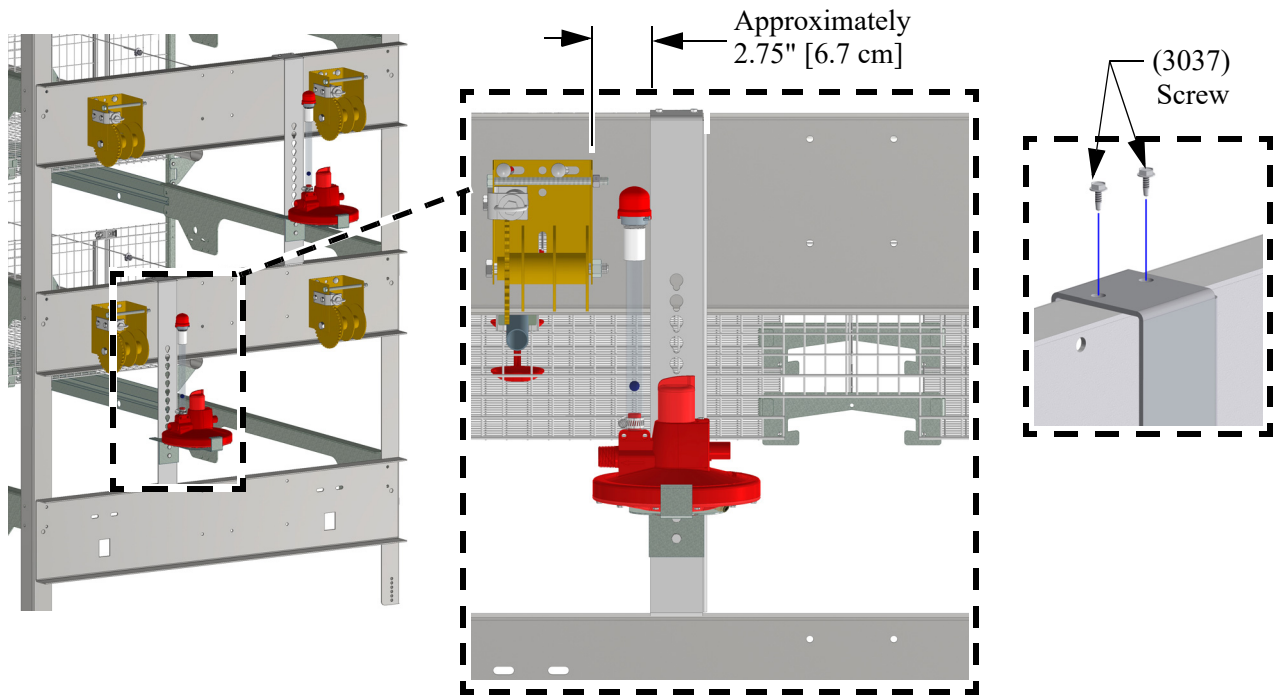

Figure 18. Installing Adjustment Bracket

Plumbing (Regulator End)

1. Cut Pipes leaving approximately 3" [7.6cm] outside 1st partition as shown.
2. Use Two PVC Ell's and a 1.5 sxsxs Tee (38618) to attach the two Nipple Pipe Lines together as shown.
3. Install a 3/4 x .50 Slip Fitting (25098).

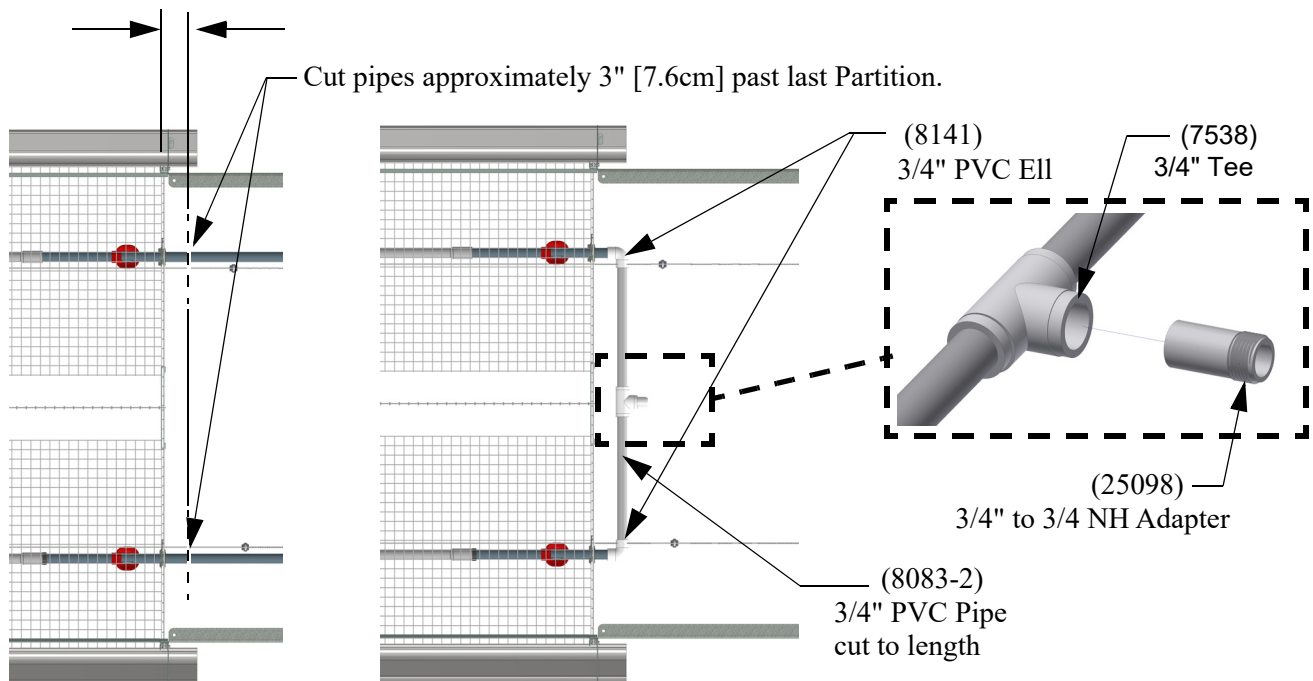
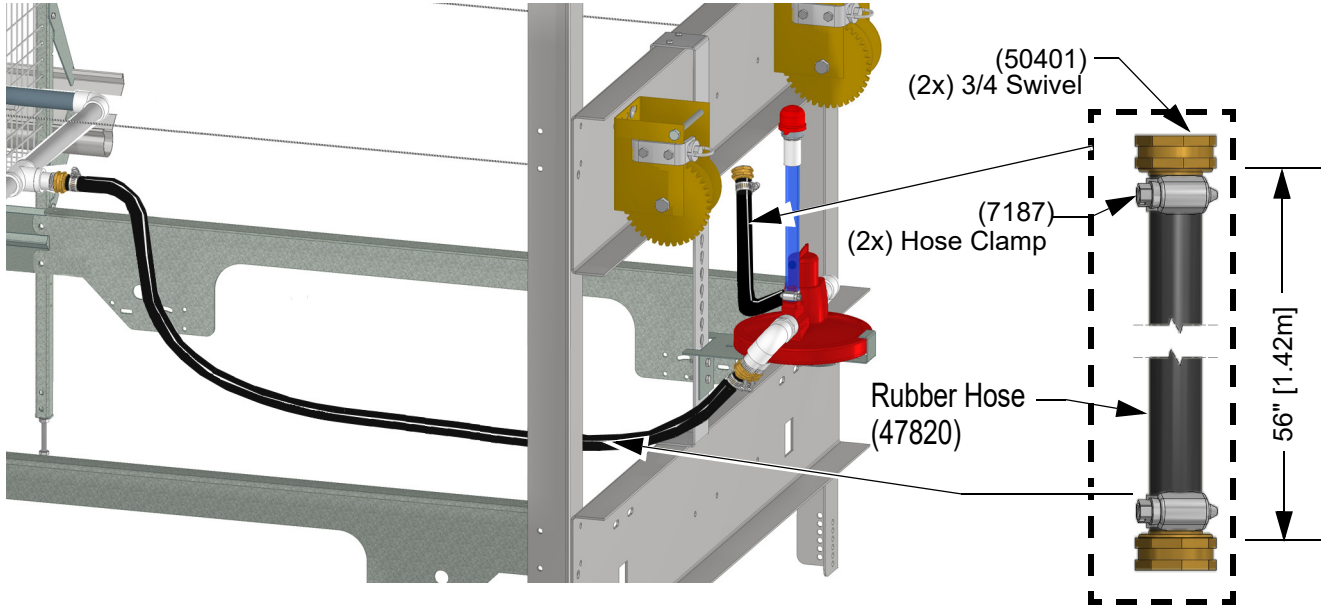

Figure 19. Connect Nipple Lines together

4. Use a 3/4" Adapter (7702), a 3/4" Ell (8141), and a Slip Fitting (25098) on the Out take side of the Regulator as shown. Angle down at a 45° to clear the Idler Back as shown. **!Important: Remember that the Regulator Assembly will need to travel up, so plan accordingly (See Figure 20.)**
5. Use a 3/4" x 1/2 Reducer (8060), a 3/4" Ell (8141), a 3/4" Ball Valve (34728), a 3/4" x 1/2 Slip Fitting and two pieces of 1/2" PVC Pipe (8083-2) cut to required length as shown. Angle at approximately 45° to clear Idler Back. **!Important: The Regulator will travel up, so plan accordingly (Figure 20.)**
6. Cut Rubber Hose (47820) to 56" and install .75 NH Female Swivel Fittings (5041) on both ends using Hose Clamps (50401). Attach Hose to Slip Fittings.



Angle at approximately 45° to clear framework.
!Important: Everything must clear in the "UP" and "DOWN" position as shown.

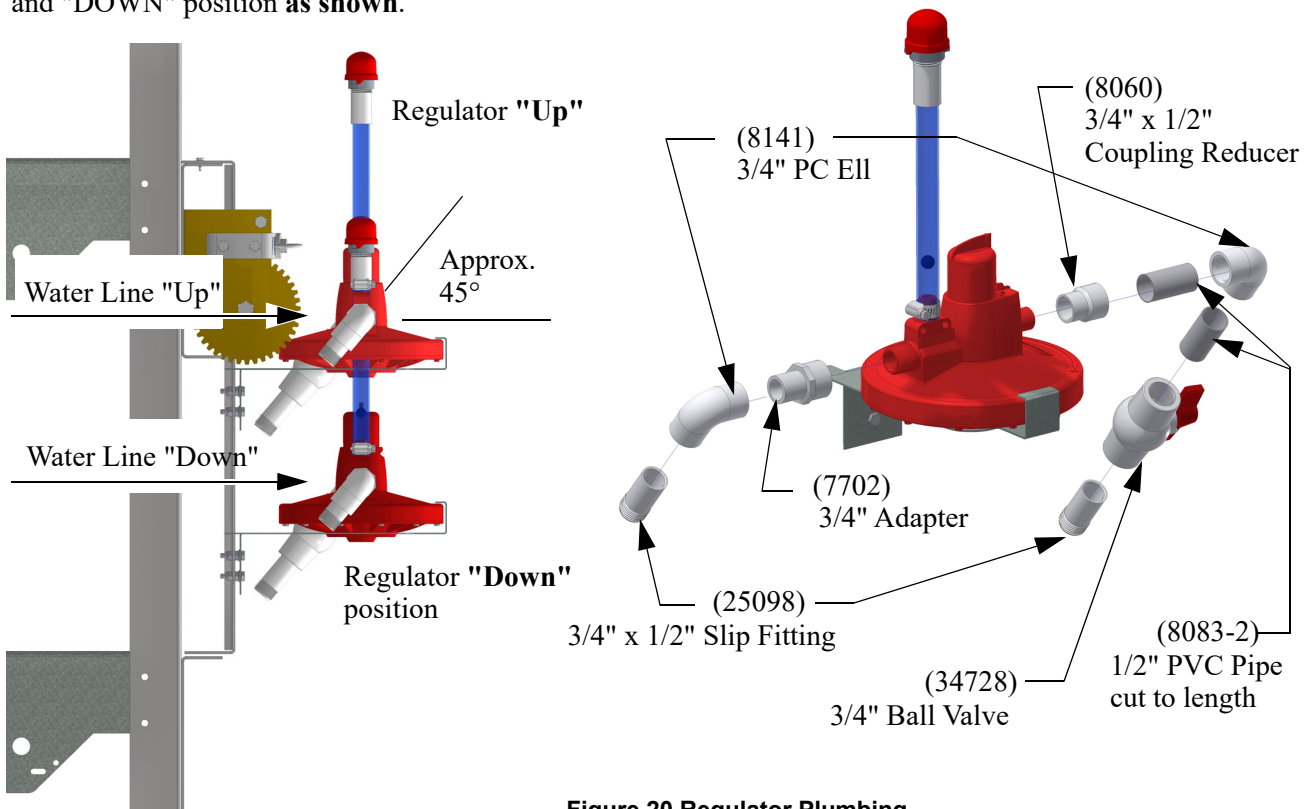

Figure 20.Regulator Plumbing

Mid-Line Assembly

By-Pass

A By-Pass is needed at each Motor location.

1. Cut the Nipple Waterer Lines (both incoming and outgoing) just inside the Motor Cage Partitions. Be sure to properly deburr the end of the pipes to prevent damage.
2. Attach a .75 PVC ELL sxs (8141) onto the end of the incoming Nipple Waterer Pipe using a slip connection.
3. Attach an outlet compensator with a right vent, left vent, or no vent, according to which side and tier is being installed (right 54035-4L, left 54035-5L, top 54035-2L) to the outgoing PVC pipe as shown in **(Figure 21.)**.
4. Measure and cut appropriate length .75 PVC pipes (8083) (5 pieces) to just span the motor opening, as shown. Be sure to properly deburr the ends of the pipes to prevent damage.
5. Join the PVC pipes using slip connections into the ELL connectors in a configuration to bypass the motor.
6. Attach a .75 union PVC sxs connector (8137) to the PVC pipes as shown in **(Figure 21.)**.
7. Cut the Wire of the cage top and front to allow for the Stand Tube.
8. Attach a Mid-Line Stand Tube Assembly (54517-X).

Important: Remove shavings, or any debris from inside Pipes

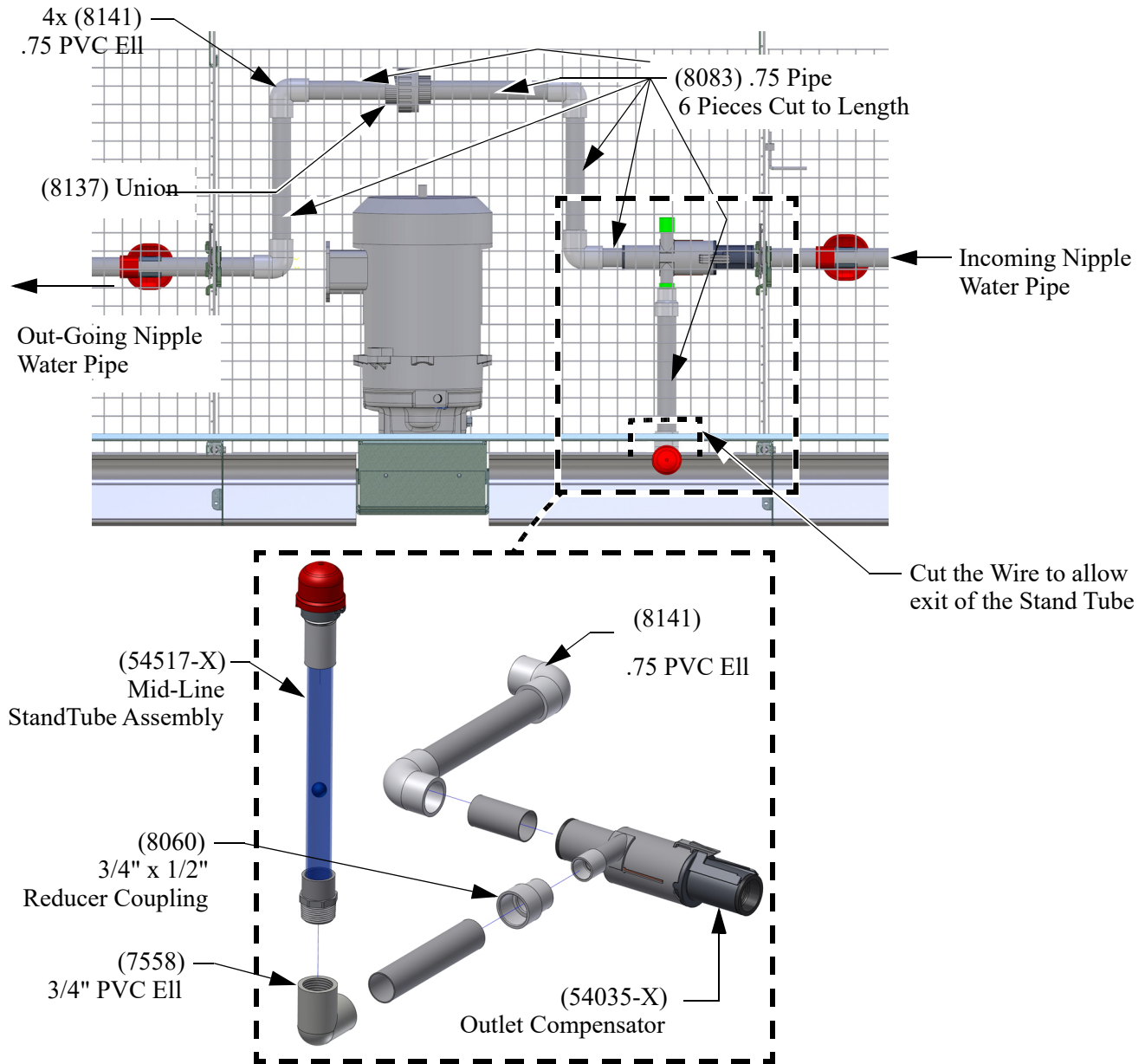

Figure 21. Motor By-Pass

End Line (Flush End) Assembly

1. At the end Line (flush end) cut the pipes approximately 3" beyond the last cage. There are NO drinkers outside the Cages. Cut both pipes on each tier the same length.

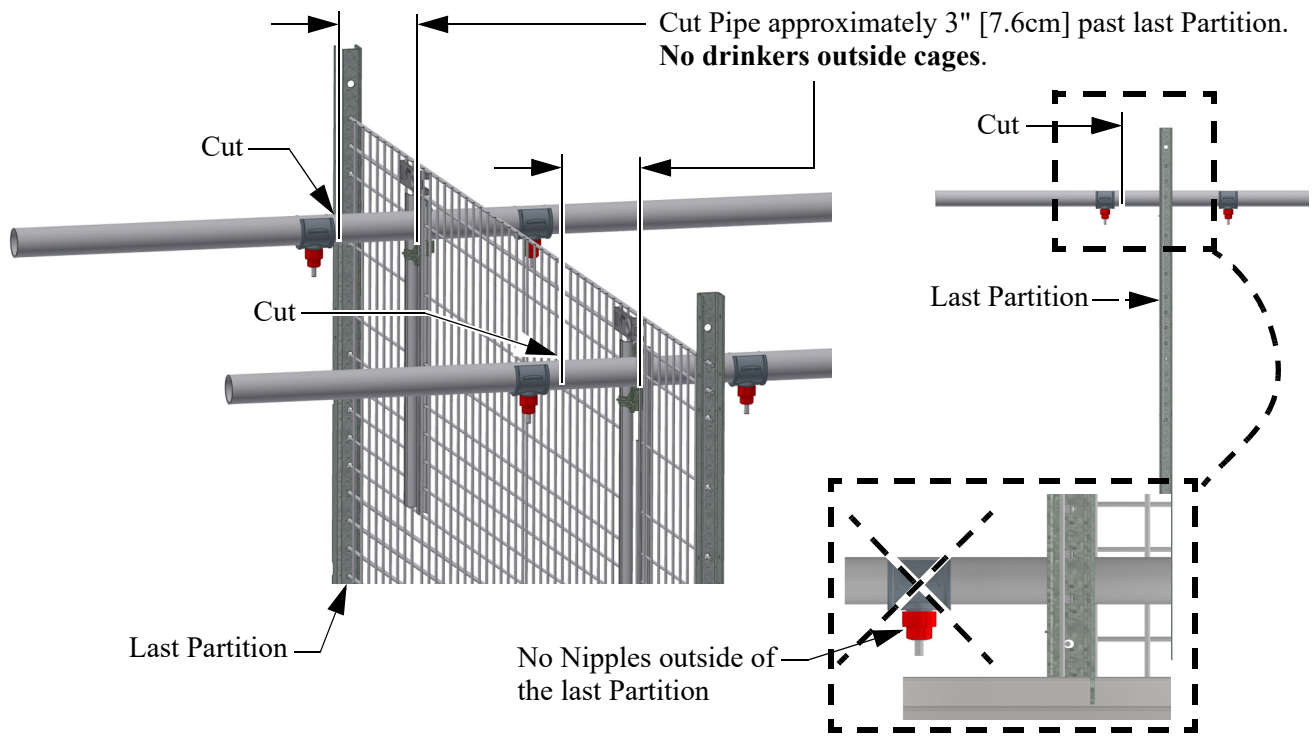

Figure 22. Cutting off Pipes at flush end

2. Install the Overflow Pipe Assembly that was assembled earlier. See “**Drain and Overflow Pipe Assembly**” on page 8.
3. At the end of the Cage Row Cut the Nipple Pipes outside the last Cage as shown below.and plumb as required to reach the Drain Overflow Pipe. **Important! There should be no Nipples outside the Partitions!** Plumb in Stand Tubes on each side if desired as shown. Make sure Stand Tubes are clear of obstructions, but do not protrude into the walkways.
4. Cut Rubber Hose (47820) to 56" and install .75 NH Female Swivel Fittings on both ends of the Hose using Hose Clamps (50401).
5. Connect one end of the Hose to the end of the line and the other end to the Drain/Overflow Pipe Assembly.

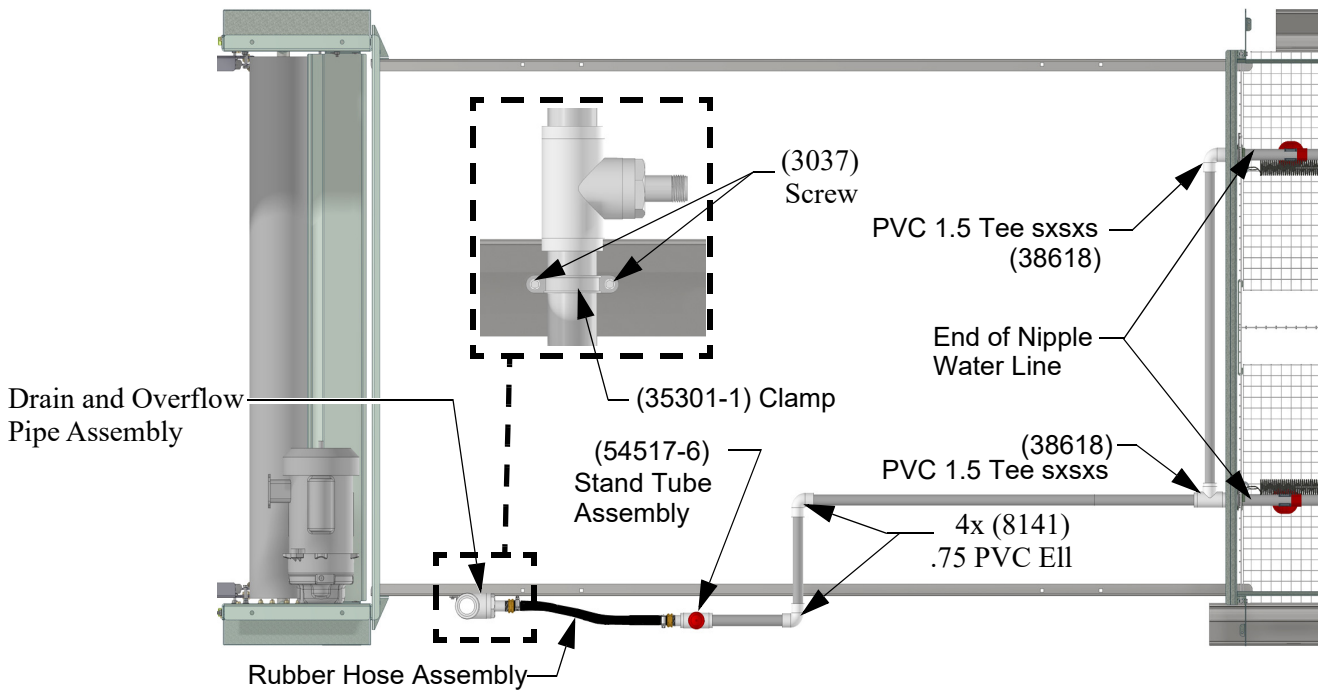
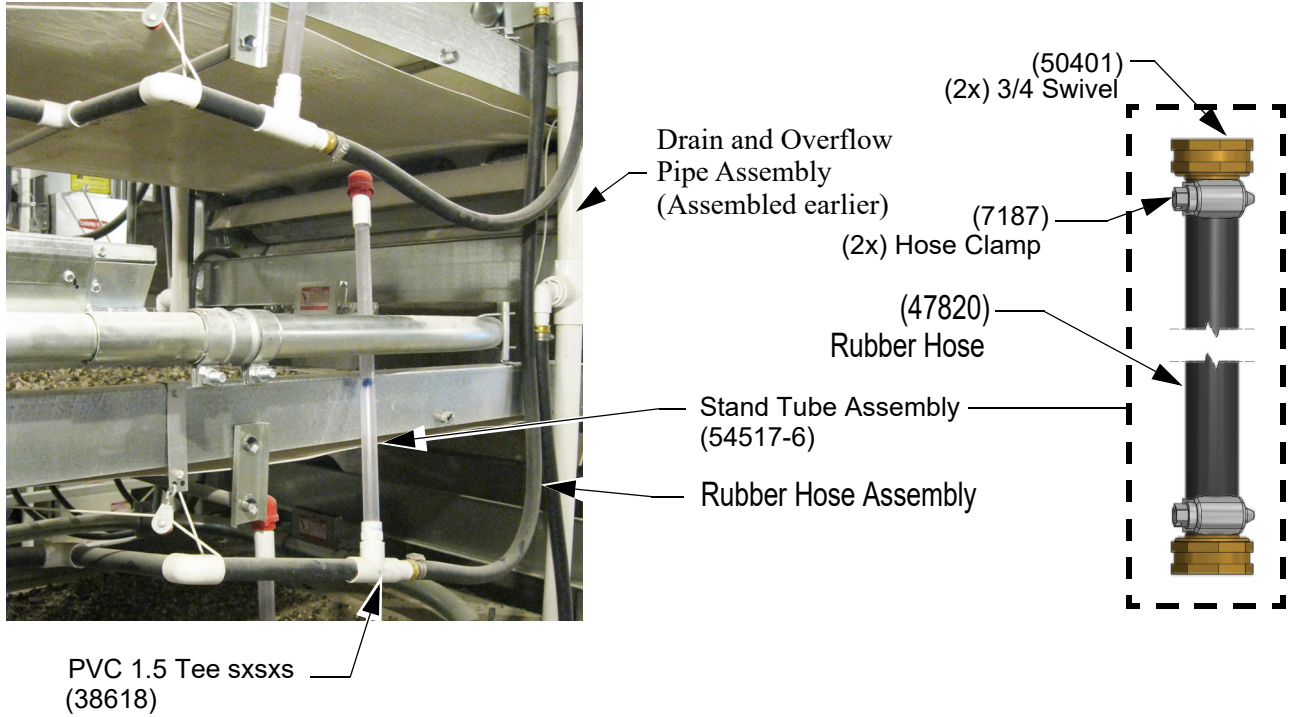

Figure 23. End Line (Flush End) Assembly

Nylon Cords

Main Line Cords

1. There should be a Cord at each Partition. Make sure that the Nylon Cords are routed through correctly (See **Figure 14, page 17**).
2. Pull the Nylon Cord towards the Winch end and fasten to the Hard Wire. (See **Figure 24.**)

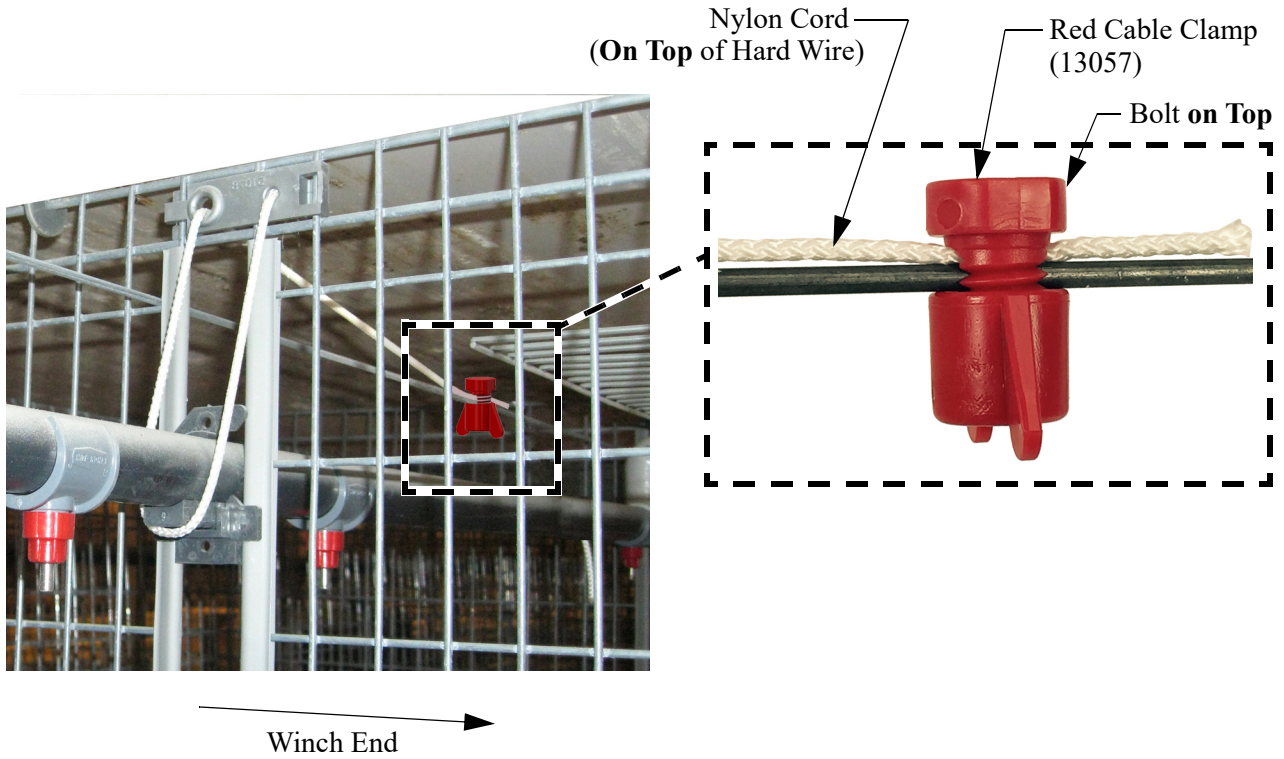

Figure 24.Fastening Nylon Cords

End Line Cords

1. Fasten a End Line Rail Bracket (51156) to the Drive Rail with a (3037) Screw directly above the end of the Watering Line as shown below.
2. Install a Stainless Hook (723) and a Pulley (44577) on the Drive Rail.
3. Tie a knot in the end of the Nylon Cord and install it as shown in (Figure 25.)

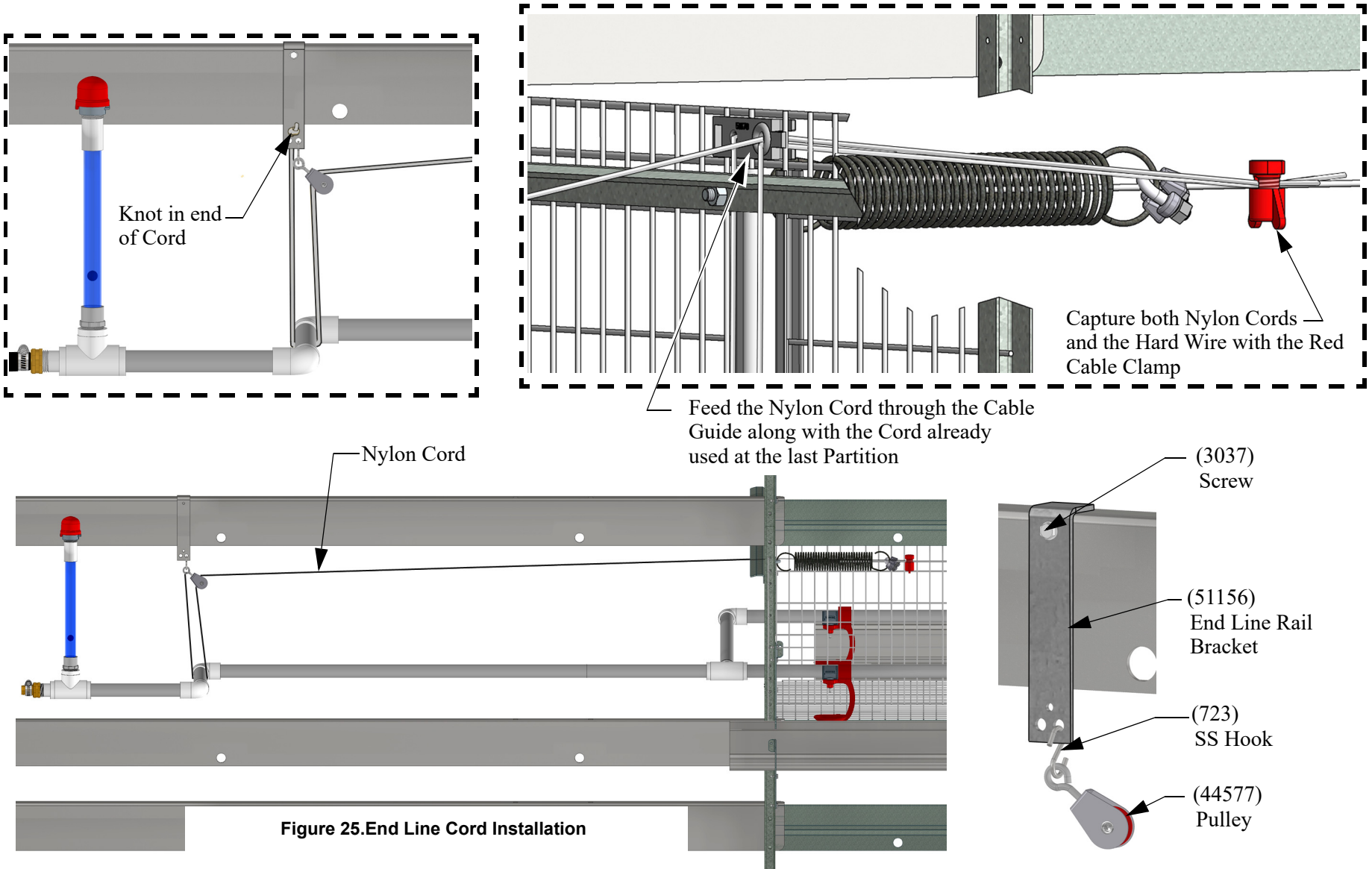

Figure 25. End Line Cord Installation

Filter Control Panel Installation

The filter control panel is used to remove foreign material from the incoming water, and, if necessary, add medication to the water.

The step down regulator and gauge assembly is used to reduce the water pressure supplying the filter control panel. The filter control panel and step down regulator should be installed in a convenient location where incoming and outgoing water supply lines can be easily run. The control panel must be out of the reach of birds.

The filter control panel is shipped secured to a mounting board. The mounting board and filter control panel should be secured to wall or post using lag bolts (not supplied).

The step down regulator and gauge assembly is shipped un-assembled. Assemble the step down regulator and gauge assembly components as specified in the instruction (MW1052) shipped with the kit.

Connect the step down regulator and gauge assembly to the filter control panel, as shown in **Figure 17**.

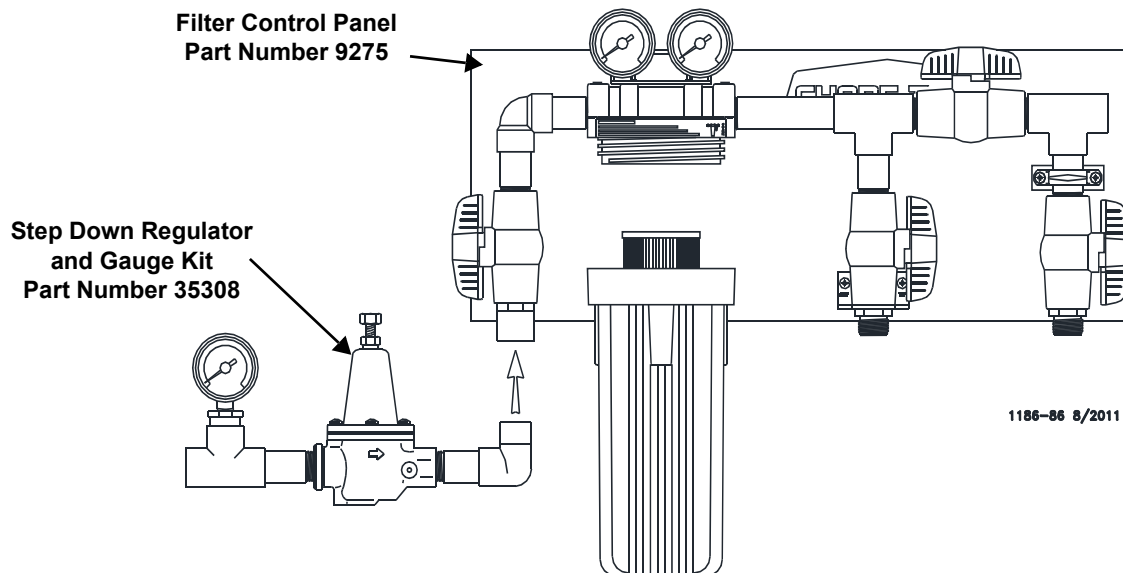

Figure 26. 9275 Control Panel

Flushable Filter Control Panel Installation

(Optional alternative to the standard filter control panel)

The flushable filter control panel is used to remove foreign material from the incoming water, and, if necessary, add medication to the water. This control panel features a filter that may be flushed, removed, cleaned, then reinstalled.

Two versions of the filter control panel are available.

The low pressure version is designed to accommodate gravity flow systems with 5 - 10 p.s.i. [34.5 - 69.0 kPa]. Do not exceed 15 p.s.i. [103.4 kPa] with this control panel, or damage will occur to the gauges.

Systems with 11+ p.s.i. [75.8+ kPa] should use the high pressure control panel. For systems above 35 psi, order a step down regulator.

The filter control panel should be installed in a convenient location where incoming and outgoing water supply lines can be easily run. The control panel must be out of the reach of birds.

The filter control panel is shipped secured to a mounting board. The mounting board and filter control panel should be secured to wall or post using lag bolts (not supplied).

The gauge assembly is shipped un-assembled. Assemble the gauge assembly components as specified in the instruction (MW1052) shipped with the kit.

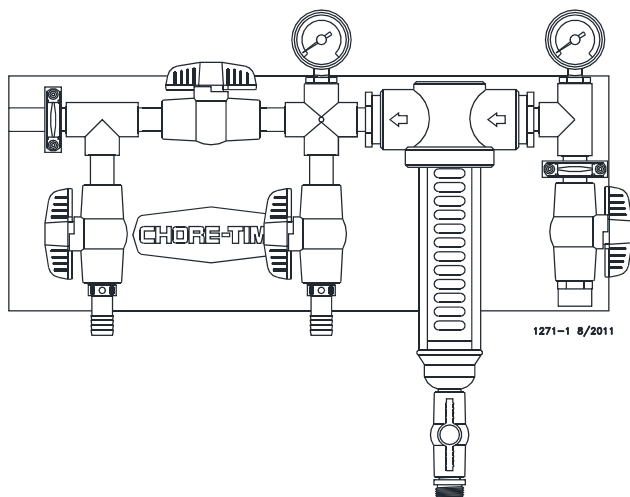

Low Pressure Control Panel
Part Number 36802-1
(5-10 p.s.i. [34.5 - 69.0 kPa])

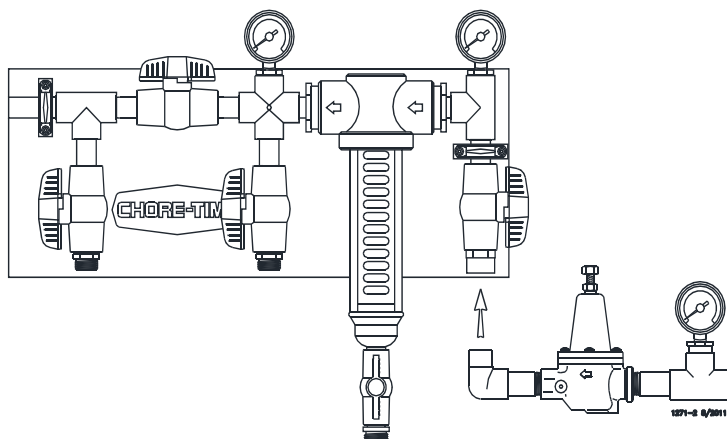

High Pressure Control Panel
Part Number 36802-2
(11+ p.s.i. [75.8+ kPa])

Figure 27.

Water Meter Installation

If using an Amco/ABB brand Water Meter, they are not polar sensitive. Therefore: when wiring a Amco/ABB Water Meter, the wire color does not matter.

Badger® Water Meter Installation

Wiring

The Badger® water meter is supplied with 10 ft. (3.05 m) of cable with red and black leads with stripped ends. When connecting to a Chore-Tronics® control, proper polarity must be maintained. The red lead is connected to the DI (digital input) of your choice, and the black lead is connected to the ground terminal of the chosen DI

Chore-Tronics™ Control
D1 of your choice



Figure 28. Water Meter Wiring

Mounting

The Badger® Water Meter must be installed with the Cap up as shown below. Refer to the Badger® installation manual for more information.

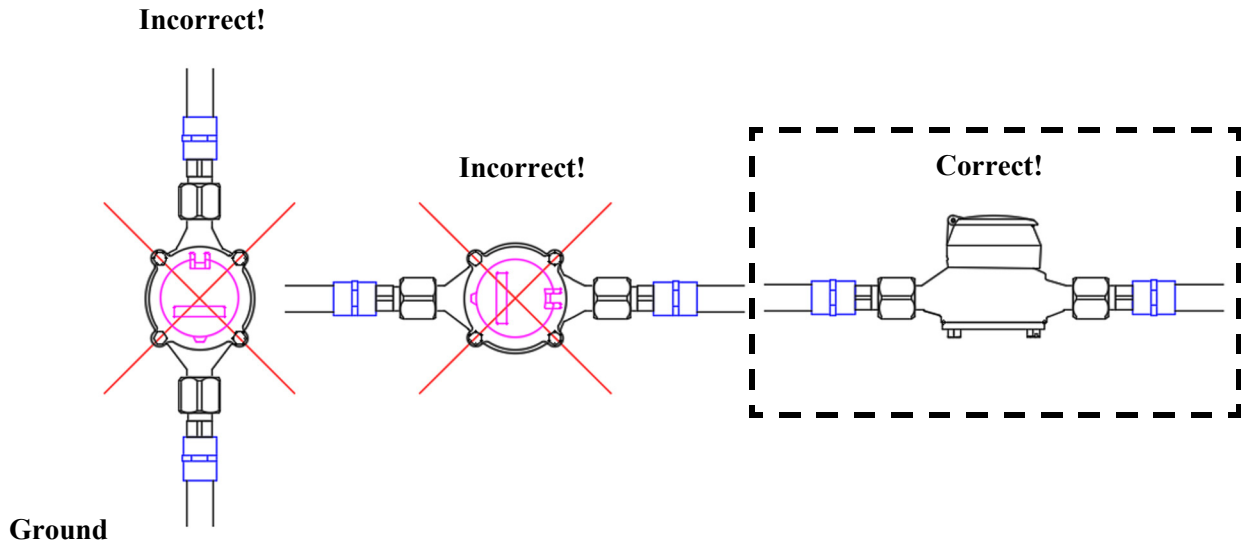

Figure 29. Water Meter Mounting

Water Meter Start Up

Attention! Air and debris in the supply line upstream of the meter installation must be removed before pressurizing the meter with water or damage to the meter is likely!

If the Water Meter is located very close to the Filter Panel- Valves #1 and #2 can be opened to remove any air and debris from the upstream piping to the inlet point of the Meter. After flushing, valve #2 can be closed and the Meter can be installed. Once installed, valve #2 must be opened **very slowly** to fill the downstream line and pressurize the Meter without damaging it.

If the water meter is not located very close to the Filter Panel- another optional valve can be installed close to the Meter. Before installing the meter, valves #1, #2 and the Optional valve can be opened to remove any air and debris from the upstream piping to the inlet point of the Meter. After flushing, the Optional valve can be closed and the Meter can be installed. Once the Meter is installed the Optional valve must be opened **very slowly** to fill the downstream line and pressurize the Meter without damaging it.

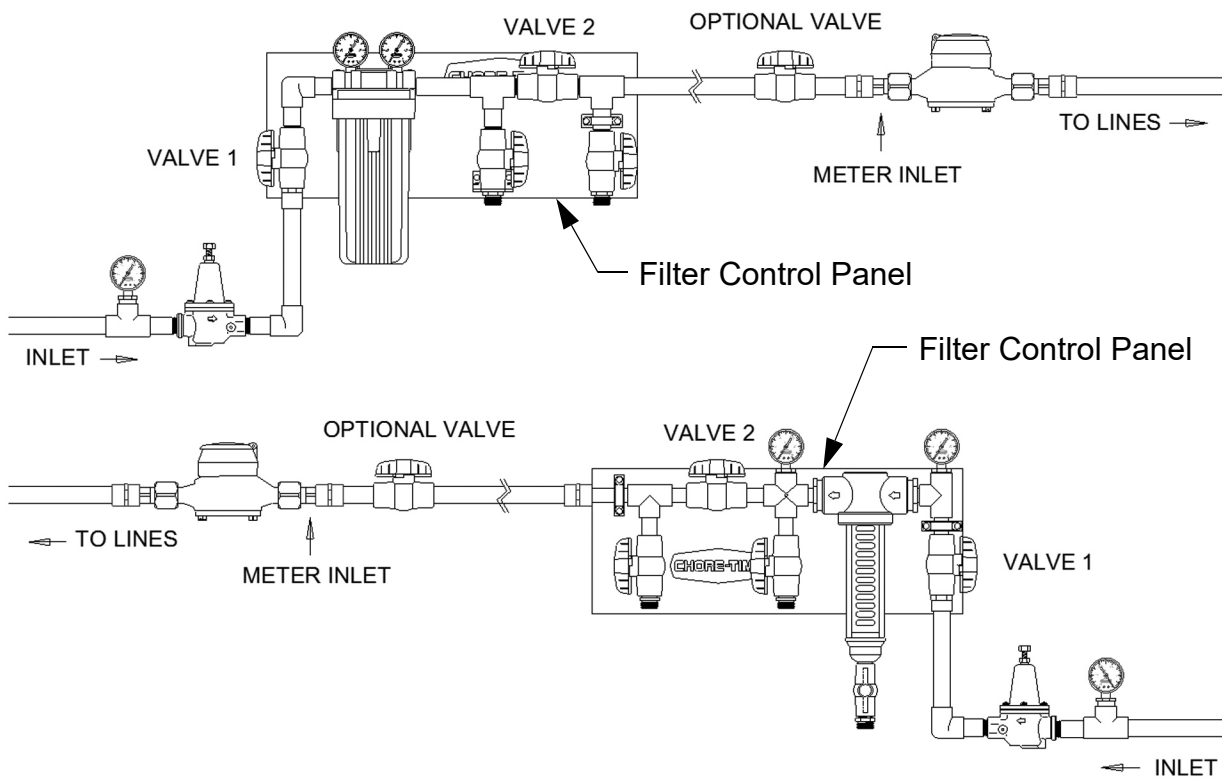
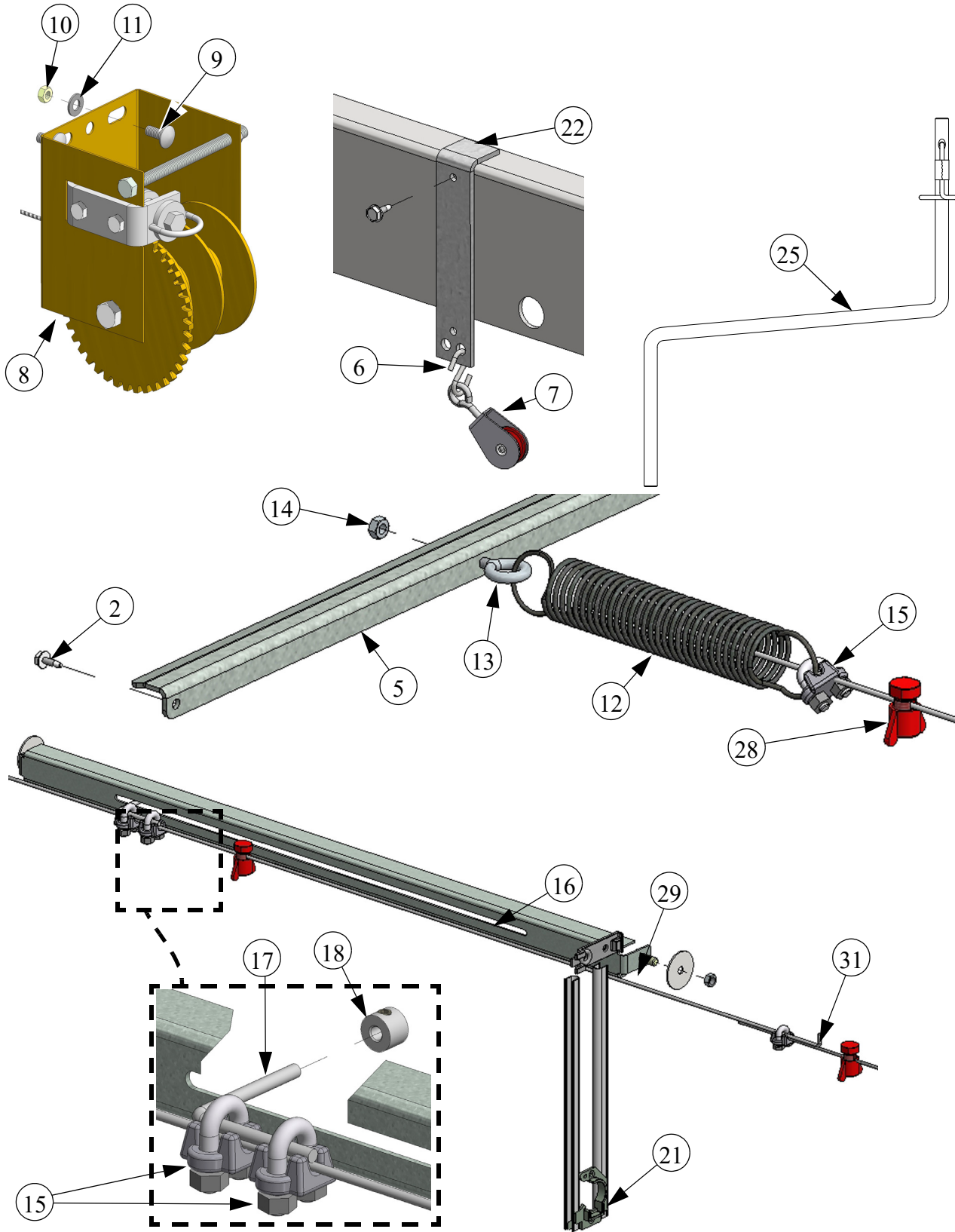

Figure 30. Water Meter Start Up

Parts Listing

Suspension Components



Hardware below is Full Scale

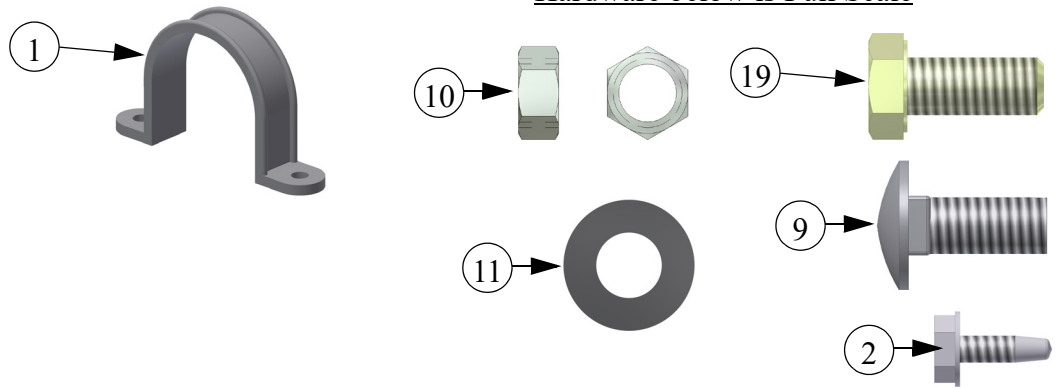

Suspension		
Item	Description	Part No.
1	Plastic Conduit Clamp	35301-1
2	10-16 x .50 Screw	3037
3	Water Regulator Kit (Shown on next page)	54536
4	Regulator Adjustment Bracket	50579-1
5	Watering Spring Brace 55.75"	50578-1
	Watering Spring Brace 57.60"	50578-2
	Watering Spring Brace 50.52"	50578-3
	Watering Spring Brace 55.75"	50578-1
6	12 Ga. Stainless Hook	723
7	.875 Nylon Pulley	44577
8	BG Nipple Winch	46058
9	5/16-18 x .75 Car. Bolt	20125
10	5/16-18 HX Nut	2145
11	.344 x .065 Washer	2230
12	1.25 x 7.5 Extension Spring	30082
13	1/4 20 x 1.75 Eyebolt	22911
14	1/4-20 Hx Nut	751
15	Cable Clamp.125	14898
16	20" Mmb Bg Anti Twist And Indicator Guide	50577
17	Bg Anti Twist/Indicator Arm	48957
18	.188x.50x.375 Set Collar	41857
19	Hh5 5/16-18x.75 Bolt	2046
20	Flat 5/16 X 1.5 Washer	E2700
21	Nipple Pipe Locator Hanger	43716
22	Drain Rail Bracket	51156
23	.562 x .250 Nylon Bushing	6343
24	Winch Drive Tube	2884-4
25	Drive Handle	2885
26	34" Rope (Not Shown)	14648-7
27	.125 Dia. Polyester Rope (Not Shown)	9247
28	Plastic Cable Clamp	13057
29	Winch Wire Guide	51678
30	1/8 x 7x7 Aircraft Cable (Not Shown)	8580
31	Wire,200' Bg Nipple Winch	46059-200
	Wire,300' Bg Nipple Winch	46059-300
	Wire,400' Bg Nipple Winch	46059-400
	Wire,500' Bg Nipple Winch	46059-500
	Wire,600' Bg Nipple Winch	46059-600

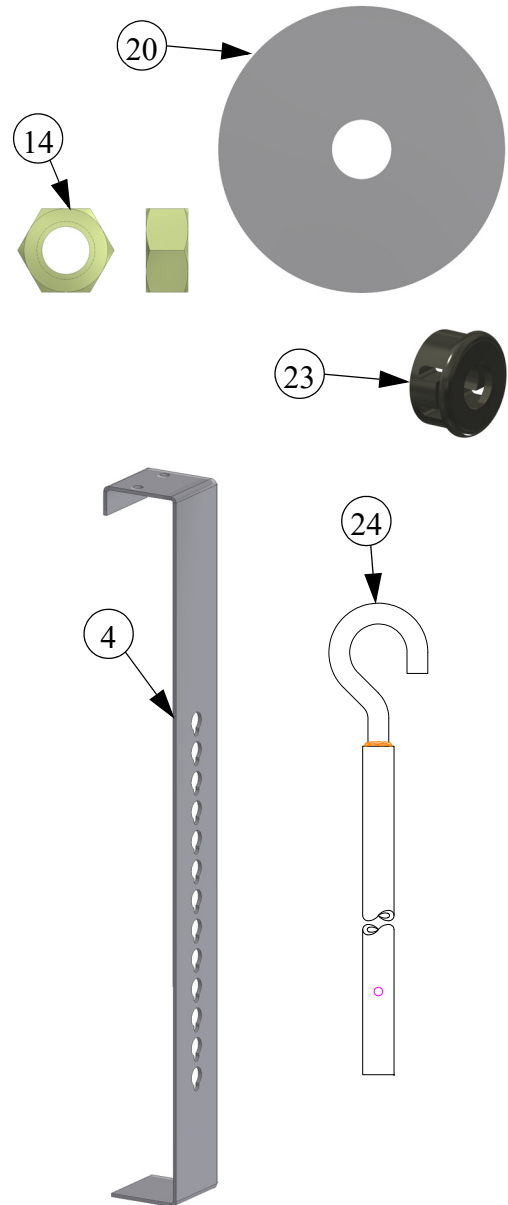

Water Line Parts

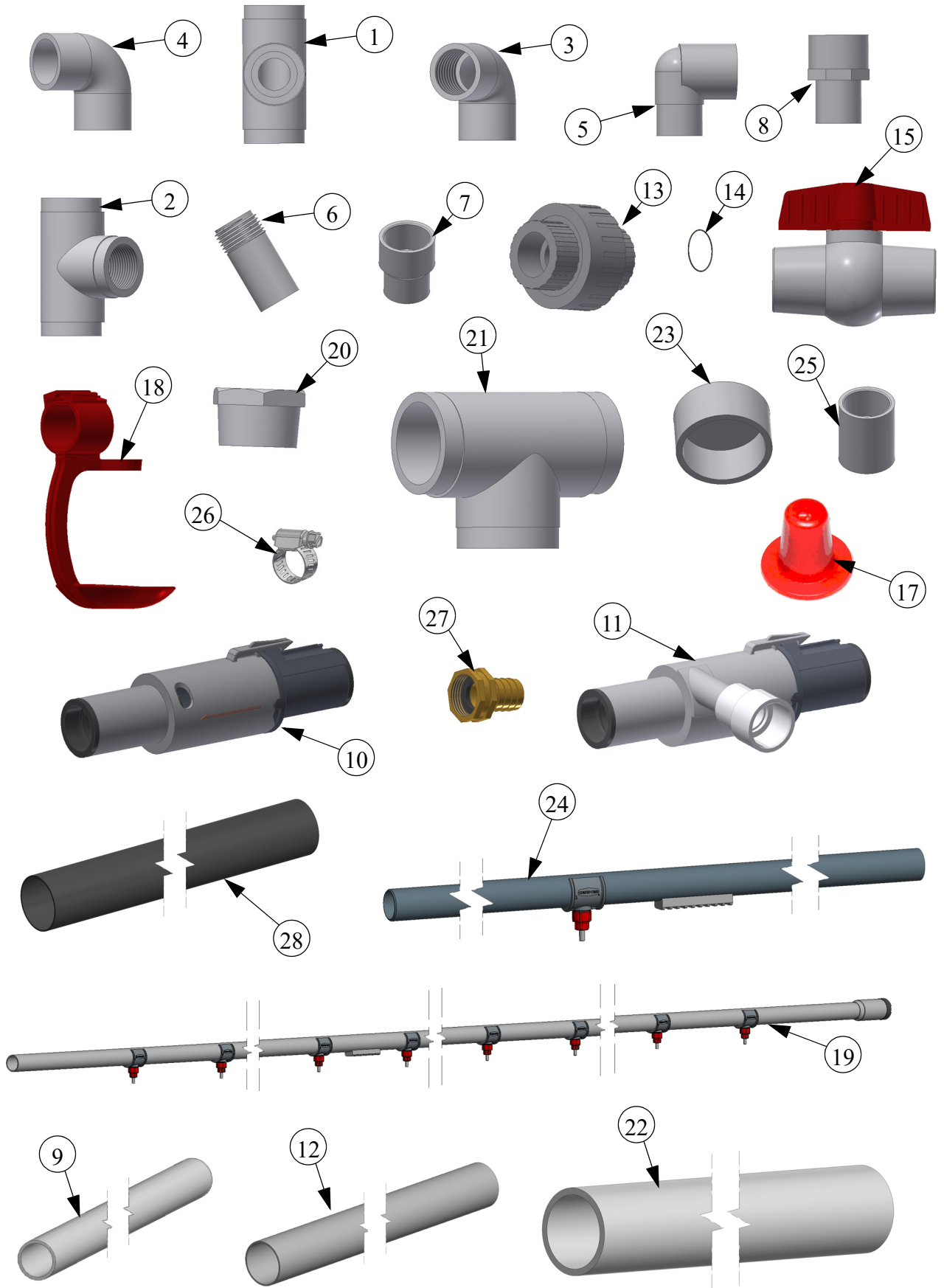

Water Line		
Item	Description	Part No.
1	3/4" PVC Tee	7538
2	.75 PVC Tee	8061
3	3/4 PVC Ell	7558
4	.75 PVC Ell	8141
5	.75 PVC Ell	30138
6	.75 Male Adapter Fitting	25098
7	.75 x .5 Reducer Coupling	8060
8	3/4 FTG Thrd. Adapter	7702
9	1.5x10ft Pvc Sch40 Pipe	38296
10	Hi Dif Slope Compensator w/o Vent	54035-1H
	Hi Dif Slope Compensator w/ Right Mach.Vent	54035-2H
	Hi Dif Slope Compensator w/ Left Mach.Vent	54035-3H (Shown)
11	Mid Line Air Remover w/Left Mach. Vent	49607-3 (Shown)
	Mid Line Air Remover w/Right Mach. Vent	49607-4
12	3/4 x 10' PVC SDR Pipe	8083-10
13	Union	8137
14	O-Ring	29118
15	3/4 Ball Valve	34728
16*	Rigid Stand Tube with 3/4NPT Fitting	54517-6
17	Tapered Nipple Cap Plug	54319-100
18	Catch Cup	50250
19	10' Cage Layer Steadi-Flow 30 Cage w/Button	50992
	10' Cage Layer Steadi-Flow 60 Cage w/Button	51001
20	.75 x 1.50 Bushing Reducer	36808
21	1.5 PVC Tee	38618
22	1.5 PVC Pipe	38296
23	1.5 PVC Cap	38498
24	STEADI-FLOW BG Nipple Pipe Section	51796
25	3/4" PVC (SXS) Coupling	7775
26	Adjustable Hose Clamp	7187
27	3/4 Female Swivel Swivel Fitting	50401
	3/4" I.D. Rubber Hose (50') [15.24m]	47820-50
	3/4" I.D. Rubber Hose (100') [30.48m]	47820-100
	3/4" I.D. Rubber Hose (200') [60.96m]	47820-200
*See "PDS™ Control (part no.'s: 54373-XX) (International part no.'s: 54373-XXIN)" on page 44.		

Water Regulator Kit (54536)

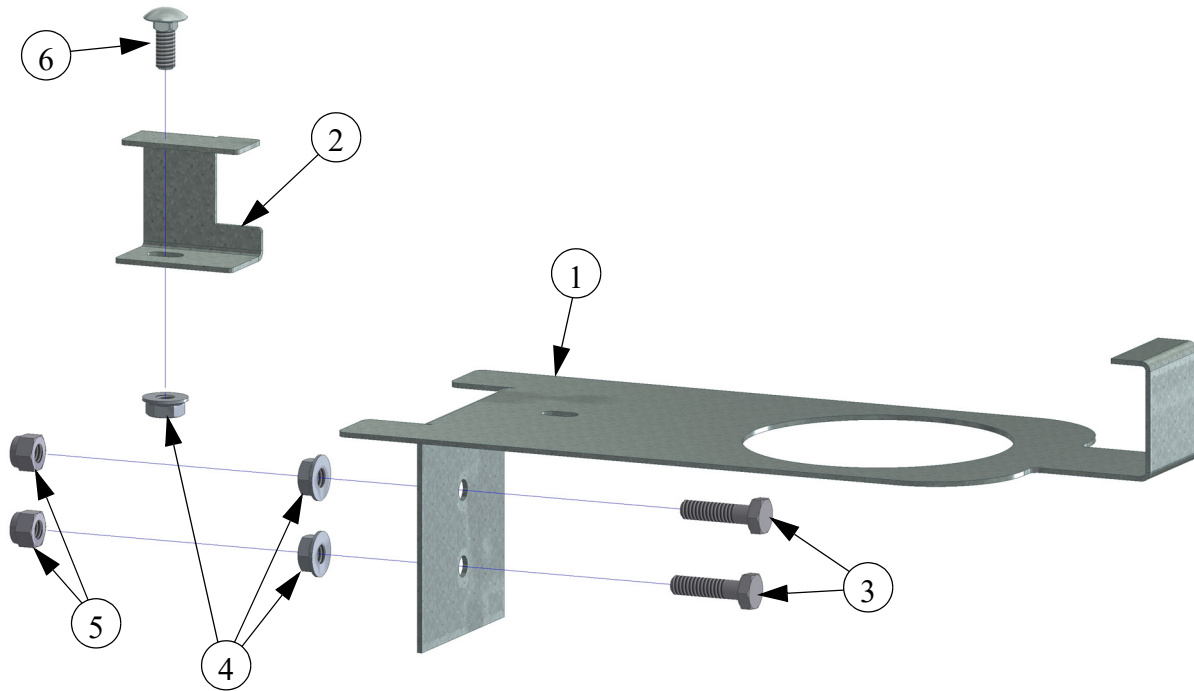

Water Regulator Kit		
Item	Description	Part No.
1	MMB BG Regulator Support	54424
2	MMB BG Regulator Clamp	53862
3	1/4-20 x 1 Bolt	2029
4	1/4-20 Serrated Flange Nut	46460
5	1/4-20 Ny Lock Nut	1269
6	1/4-20 x .50 Car. Bolt	7550-1

Hardware below is Full Scale

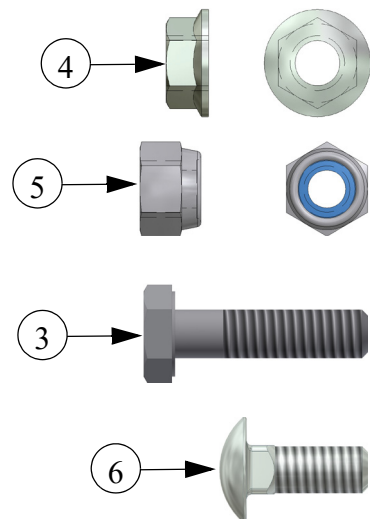

Water Conditioning Equipment

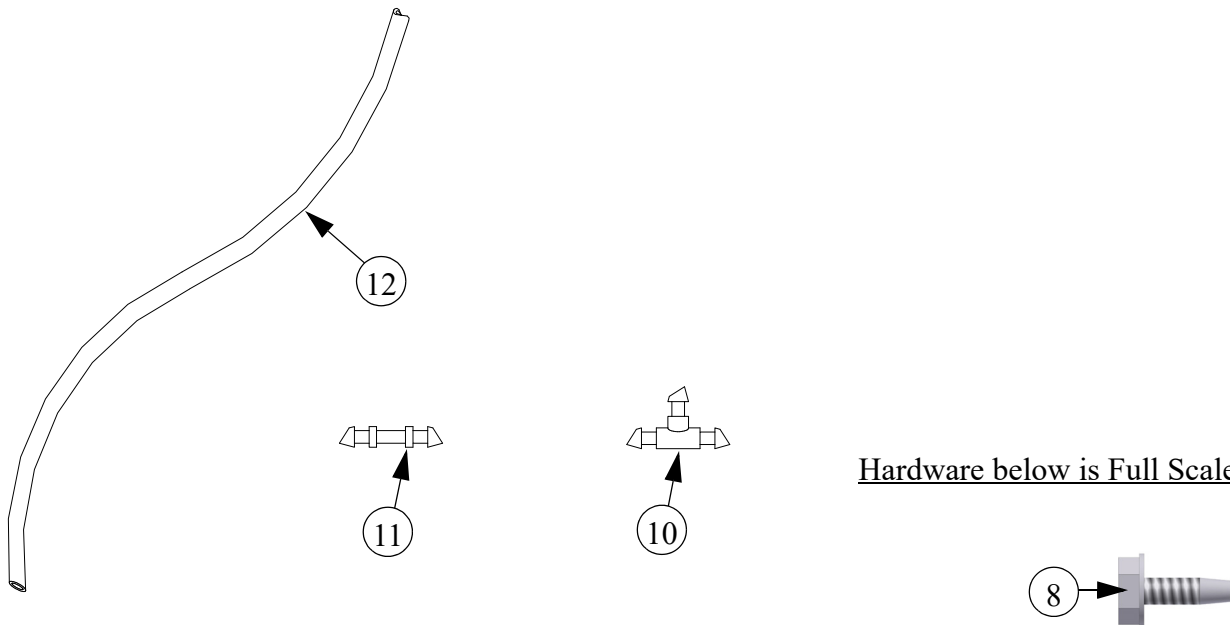

Water Conditioning Equipment		
Item	Description	Part No.
1*	Filter Control Panel (See Assembly next Page)	9275
2**	Filter Control 5-10 PSI Flush	36802-1
	Filter Control 11PSI & Up	36802-2
3***	3/4 Water Meter w/Connections	54579-G
	3/4 Pulser Water Meter w/Connections	54579-GP
	Liter Water Meter w/Connections	54579-CM
4*	Step Regulator & Gauge Module Kit	35308
5	1:100 Chemilizer Medicator (Not Shown)	41778-1
6****	Manual Adjust 3/4 FPT Outlet Cage Water Regulator	42400-11
7****	PDS Manual Adjust 3/4 FPT Outlet Cage Water Regulator	42400-14
8	10-16 x .50 Screw	3037
9	PDS 4 station Control	52430-4
	PDS 8 station Control	52430-8
	PDS 12 station Control	54373-12
	PDS 16 station Control	54373-16
	PDS 20 station Control	54373-20
	PDS 24 station Control	54373-24
	PDS 28 station Control	54373-28
PDS 32 station Control	54373-32	
10	1/4" Coupling	45893
11	1/4" Tee	45894
12	1/4" Tubing	45895-500
*See "Filter Control Panel with Step Regulator" on page 36.for individual parts that make up this assembly. **See "Flush able Filter Control Panel (36802-1 and 36802-2)" on page 37.for individual parts that make up this assembly. ***See "Pulse Water Meter (54579)" on page 38.for individual parts that make up this assembly. ****See "Regulator Assembly Manual (55476-4) and PDS (55476-5) Adjust)" on page 40.		

Filter Control Panel with Step Regulator

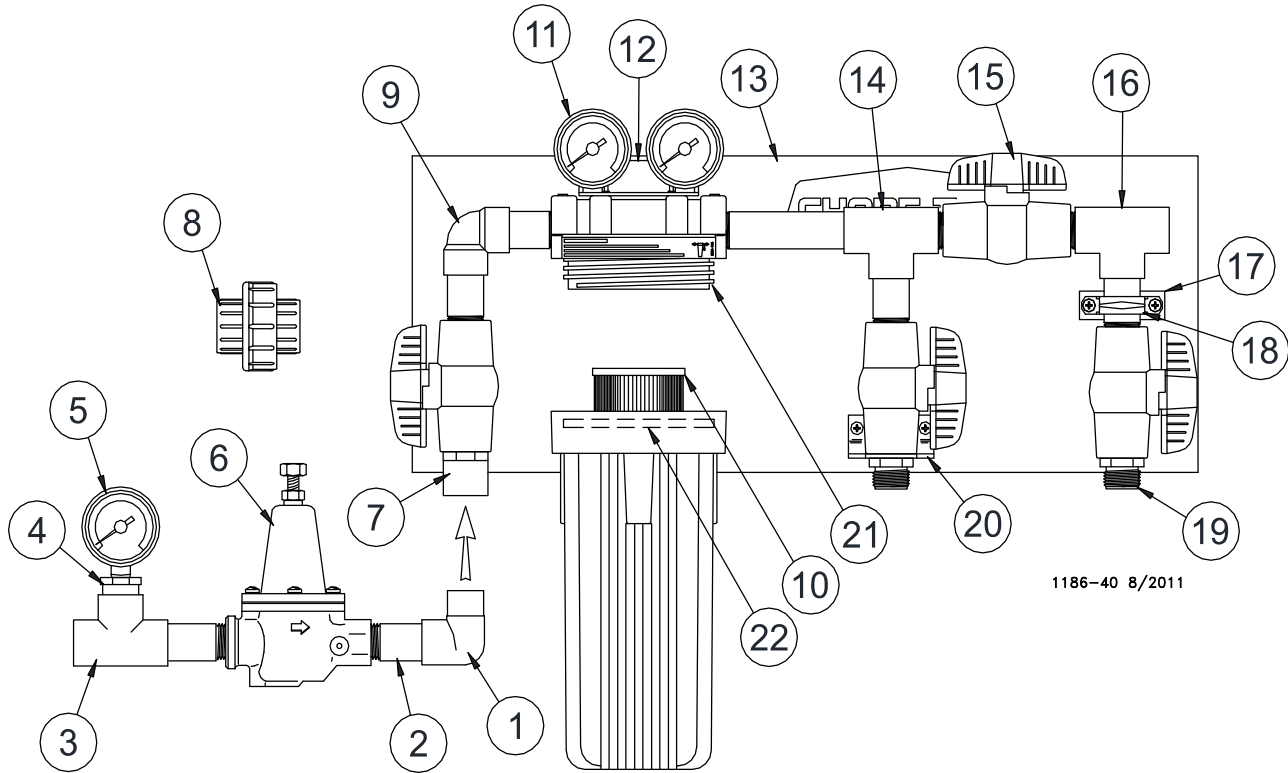

Item	Description	Part No.
1*	3/4" PVC Street Ell	30138
2*	3/4" Threaded PVC Nipple	7531-1
3*	3/4" PVC Tee	7538
4*	3/4 x 1/4 Reducer Bushing	7789
5*	High Press. Water Gauge	7191
6*	Regulator	29951
7**	3/4" PVC Male Adapter	34100
8*	Union	8137
9**	3/4" PVC Ell	8141
10**	10 Micron Filter Cartridge (Optional)	13145
	20 Micron Filter Cartridge (Standard)	7723
11**	High Press. Water Gauge	7191
12**	Filter Mounting Bracket	35302
13**	Mounting Board	35303
14**	Filter Outlet Assembly	35304
15**	3/4" Quarter Turn Valve	35781
16**	Medicator Outlet Assembly	35305
17**	Standoff Block	35300
18**	Plastic Conduit Clamp	35301
19**	3/4" Nylon Adapter	7543
20**	Medicator Connector Brace	35307
21**	Water Filter	35309
22	O-Ring	9191
<p>*These components may be ordered as an assembly under Part No. 35308.</p> <p>**These components may be ordered as an assembly under Part No. 9275.</p>		

Flush able Filter Control Panel (36802-1 and 36802-2)

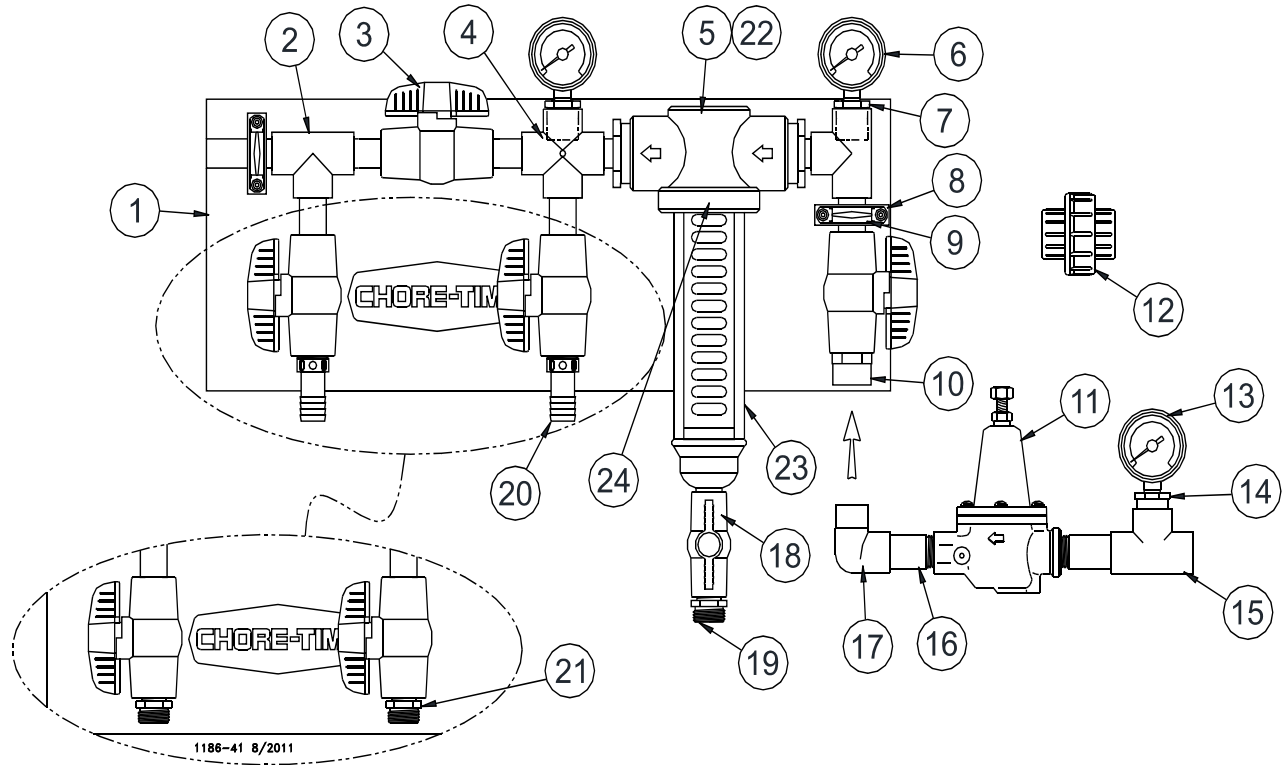

Item	Description	36802-1 36802-2	
		Part No	Part No
1	Mounting Board	35303	35303
2	Meditator Outlet Assembly	36805	36805
3	3/4" Valve	35781	35781
4	3/4" Cross	7536	7536
5	Filter Inlet Assembly	36810	36810
6	Pressure Gauge	27722	7191
7	3/4" x 1/4" Reducer Bushing	7789	7789
8	Standoff Block	35300	35300
9	3/4" Plastic Conduit Clamp	35301	35301
10	3/4" PVC Male Adapter	9229	9229
11*	Step Regulator	29951	---
12*	Union	8137	---

Item	Description	36802-1 36802-2	
		Part No	Part No
13*	High Pressure Gauge	7191	---
14*	3/4" x 1/4" Reducer Bushing	7789	---
15*	3/4" PVC Tee (S x S x S)	7538	---
16	3/4" Threaded PVC Nipple	7531-1	---
17	3/4" PVC Street Ell	30138	---
18**	1/2" Ball Valve	34961	34961
19**	Nylon Adapter	29141	29141
20	3/4" Barb x 3/4" Pipe Adapter	27422	---
21	3/4" Male Adapter (Nylon)	---	7543
22	Flush able Filter	36806	36806
23**	Filter Cover	46993	46993
24	O-Ring Kit	36807	36807

*Items not included with the flush able filter control panel. They may be ordered separately as a assembly, Part No. 35308.

**Included with Item 5.

Pulse Water Meter (54579)

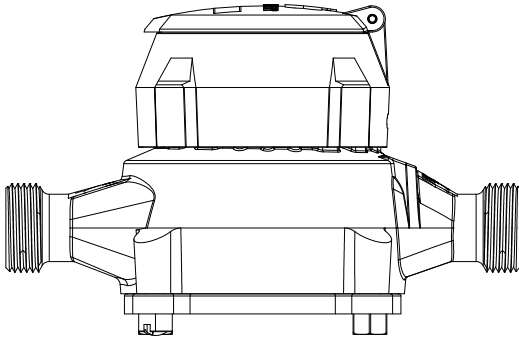

Part Number	Flow Range	Max. Operating Pressure
54579-G	.25-25 GPM	150 PSI
54579-GP	.25-25 GPM	150 PSI
54579-CM	.25-25	150 PSI

Slope Compensator (54035)

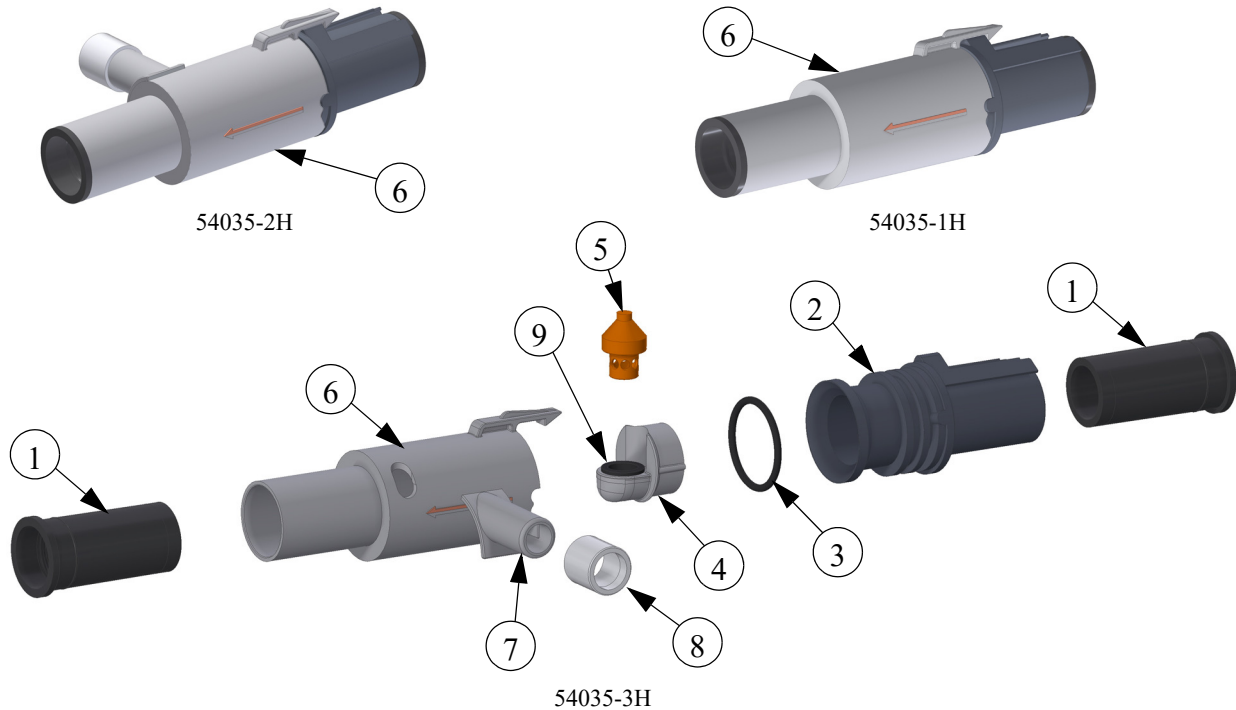

		54035-1H High Dif. w/o Vent	54035-2H High Dif. w/ Right Vent	54035-3H High Dif. w/ Left Vent
Item	Description	Part No.		
1	Half Liner	36501	36501	36501
2	Inlet Compensator	46464	46464	46464
3	O-Ring	44015	44015	44015
4	Slope Compensator Holder	53625	53625	53625
5	Plunger	46451	46451	46451
6	Outlet Compensator	36505-3	36505-6	36505-5
7	Compensator Vent Port	--	37557	37557
8	CTWR Bushing	--	42391	42391
9	Slope Compensator Insert	53624	53624	53624

Mid Line Body Assembly /Motor Bypass (49607)

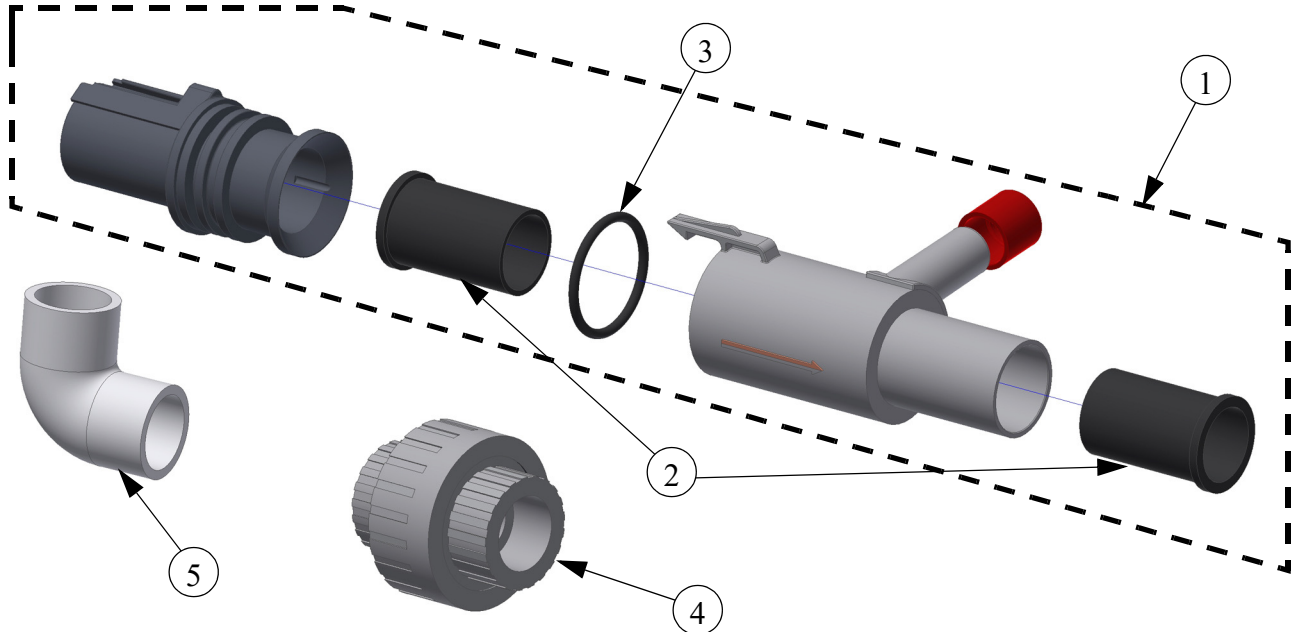

49607-3 Shown (Left Vent)

Item	Description	Part No.
1	Air Remover w/Left Vent	49607-3
	Air Remover w/Right Vent	49607-4
2	Half Liner	36501
3	O-Ring	44015
4	3/4 PVC Union	8137
5	3/4 PVC Ell	8141

Regulator Assembly Manual (55476-4) and PDS (55476-5) Adjust

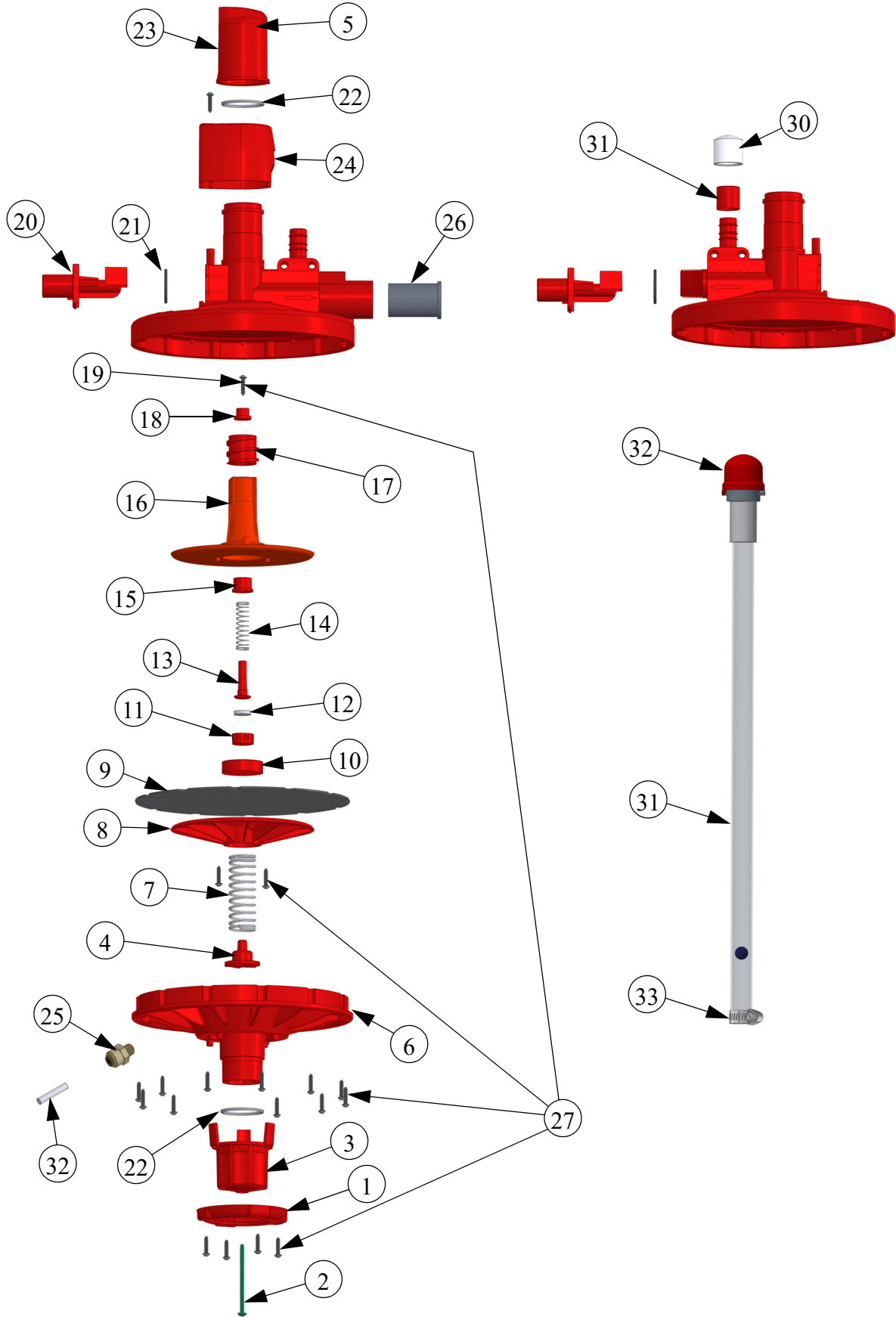

		Regulator Assembly	
		55476-4 NPT Standard Spring No Stand Tube	55476-5 NPT Outlet Standard Spring Rigid Stand Tube
Item	Description	Part No.	Part No.
1	Knob Retainer	55477	55477
2	#8-18 x 2-1/2" Screw	42387	42387
3	Adjustment Knob	55478	55478
4	Follower	42183	42183
6	Bottom Regulator Half	55479	55479
7	.78 x 2.8" Spring	42393	42394
8	Diaphragm Plate	42177	42177
9	Diaphragm	42181	42181
10	Diaphragm Center Support	42186	42186
11	Seat Cup	48199	48199
12	Seat	48225	48225
13	Seat Holder	42189	42189
14	.375 ID x 1.75" Spring	42392	42392
15	Seat Holder Sleeve	42187	42187
16	Top Diaphragm Plate	42182	42182
17	Barrel	42172	42172
18	Seat Holder Cap	42176	42176
19	Top Half Regulator	42174-1	42174-1
20	Inlet Orifice	42190	42190
21	O-Ring	29118	29118
22	O-Ring	42389	42389
23	Selector Knob	42178	42178
24	Shroud	42390	42390
25	1/8-27 NPT x 1/4 Tube Conn.	50820	50820
27	#6 x .625 Screw	52025	52025
30	Plug	55837	55837
31	Stand Tube Assembly	--	54517-4
32	Breather Cap Assembly	--	37142
33	Hose Clamp	--	7187

4 Station PDS™ Control 52430-4 and 8 Station PDS™ Control 52430-8

MM2397B

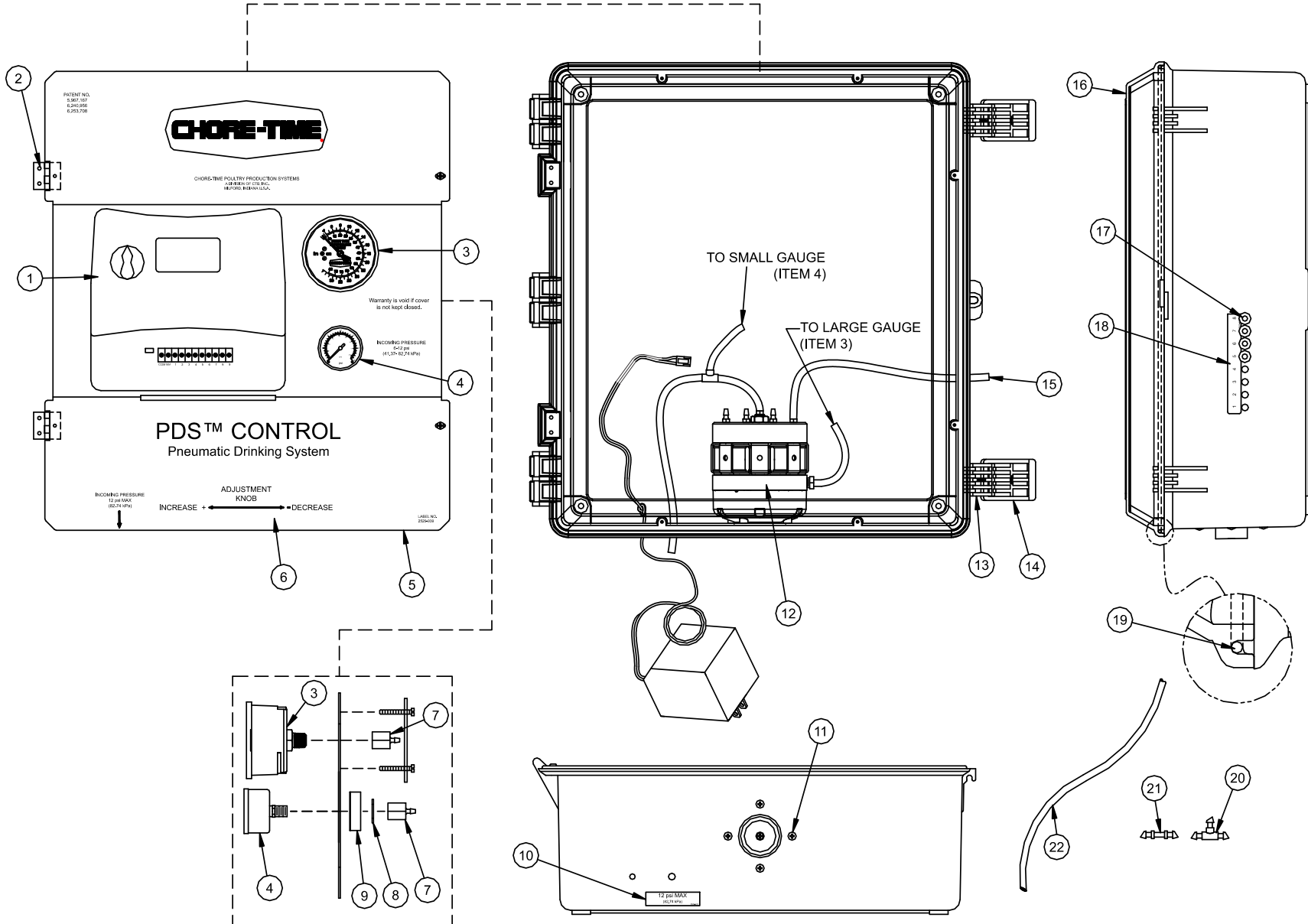

		52430-4	52430-8
Item	Description	Part No	Part No
1	120V Timer Control	52412-1	52412-2
2	Hinge	49482	49482
3	Water Column Gauge	44029	44029
4	Air Pressure Gauge	48585	48585
5	Control Plate	52411	52411
6	Control Decal	2529-939	2529-939
7	1/8" Female Pipe Adapter	48586	48586
8	1/2" Machine Washer	2499	2499
*9	Gasket	6968-1	6968-1
*10	Max Pressure Decal	2526-437	2526-437
11	#6-20 x 5/8" Screw	48577	48577

		52430-4	52430-8
Item	Description	Part No	Part No
13	Control Box Latch Pivot	30863	30863
14	Control Box Latch	30862	30862
*15	1/4" O.D. Tubing	48574	48574
16	Control Box Lid	42683	42683
17	1/4" Plug	48588	48588
18	Station Number Decal	2526-430	2526-430
*19	1/8" Diameter Seal	34767	34767
20	1/4" Tube Coupling Tee	45894	45894
21	1/4" Tube Coupling	45893	45893
22	1/4" O.D. Tubing (500 Ft Roll)	45895-500	45895-500

*Item sold in Feet.

PDS™ Control (part no.'s: 54373-XX) (International part no.'s: 54373-XXIN)

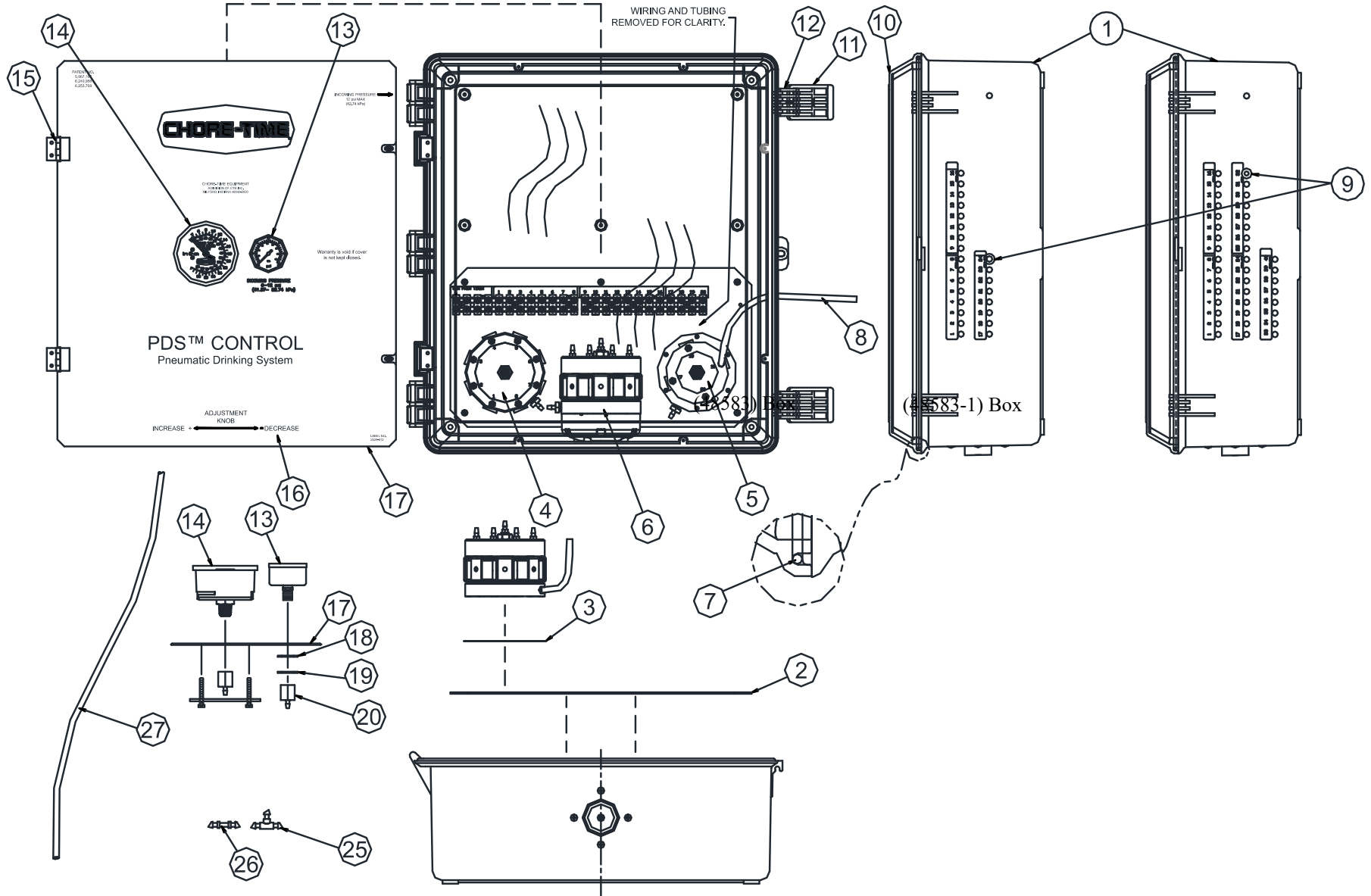

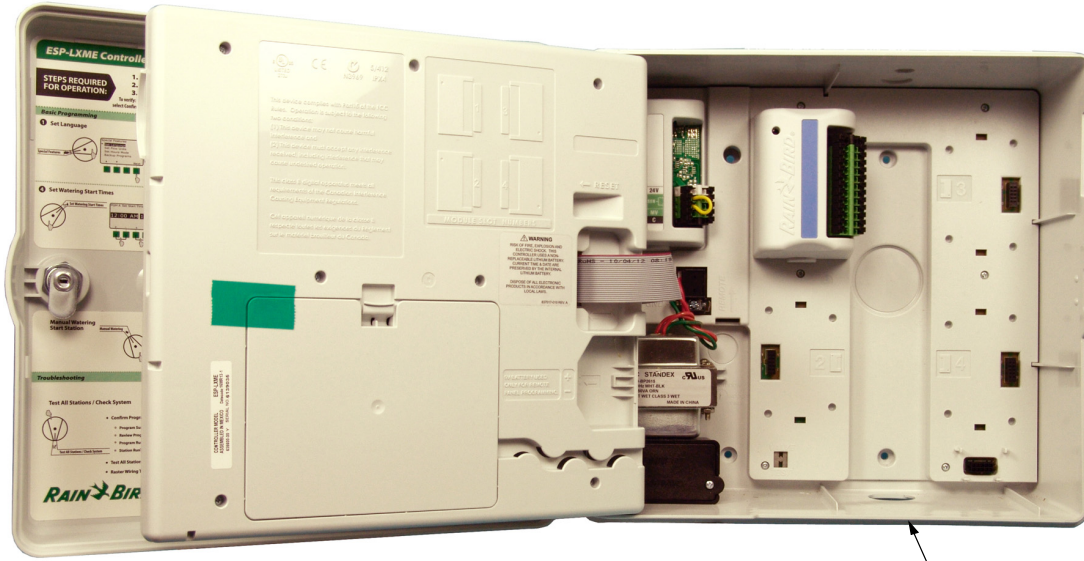

21



22**



23**



24**

Item	Description	Part No.
1	Control Box	48583
		48583-1
2	Lower PDS™ Plate	46333-1
3	Diaphragm	35891
4	8 Station Airloader	44452
5	4 Station Airloader	44451
6	8 Station Airloader W/Knob	48584
7	Seal	34767
8	Flexible Hose	48574
9	Caplug	48588
10	Control Box Lid	42683
11	Control Box Latch	30862
12	Control Box Latch Pivot	30863
13	PSI Gauge	48585
14	Water Column Gauge	44029
15	Panel Hinge	49482
16	PDS™ Control Decal	2529-812
17	Front Plate	46334-1
18	Neoprene Washer	2955-59
19	Washer	2499
20	Hose Adapter	48586
**21	12 Station Rain Bird® Control	54371-12
	12 Station Rain Bird® Control (International)	54371-12IN
**22	4 Station Module	54372-4
**23	8 Station Module	54372-8
**24	12 Station Module	54372-12
25	1/4" Connector Tee	45894
26	1/4" Coupling	45893
27	1/4" O.D. Tubing (500')	45895-500

****These components are individually boxed. Contact your nearby Chore-Time distributor or representative for additional Rain Bird® Control parts and information.**

Stand Tube Assembly

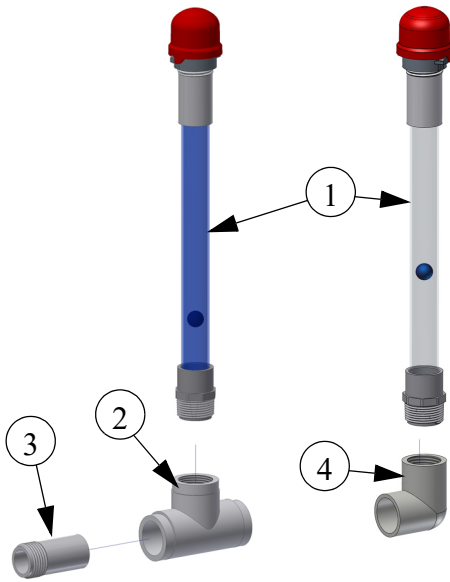

		End Line	Mid Line
Item	Description	Part No.	
1	Stand Tube Assembly	54517-6	54517-6
2	3/4 PVC sxsxtx Tee	8061	--
3	3/4 Thread .50 Slip Fitting	25098	--
4	3/4 PVC Ell	--	7558

Misc. Components List

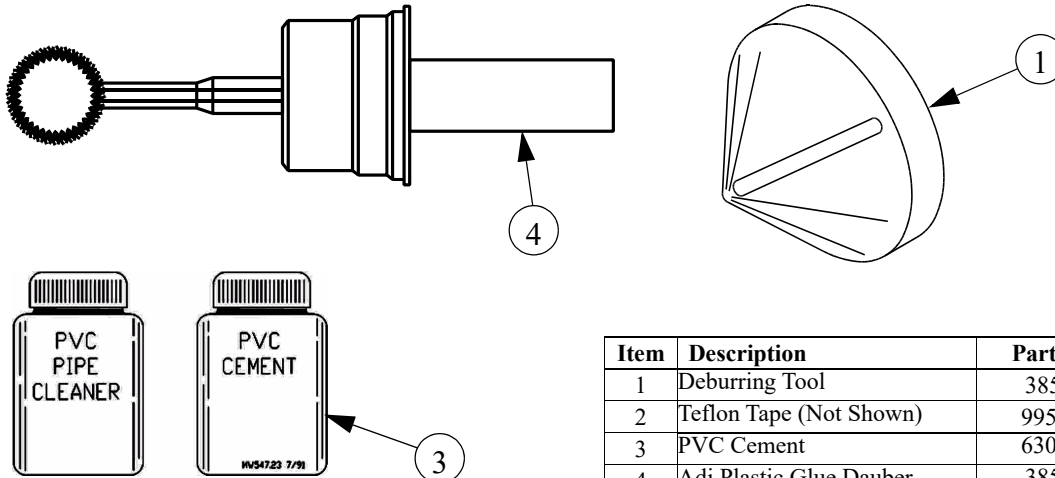

Item	Description	Part No.
1	Deburring Tool	38514
2	Teflon Tape (Not Shown)	9954-1
3	PVC Cement	6303-4
4	Adj Plastic Glue Dauber	38513
5	Layer Watering Operator Kit (Not Shown)	50991-2
6	Lubricant (Not Shown)	45911

Drain/Overflow Assembly Parts List

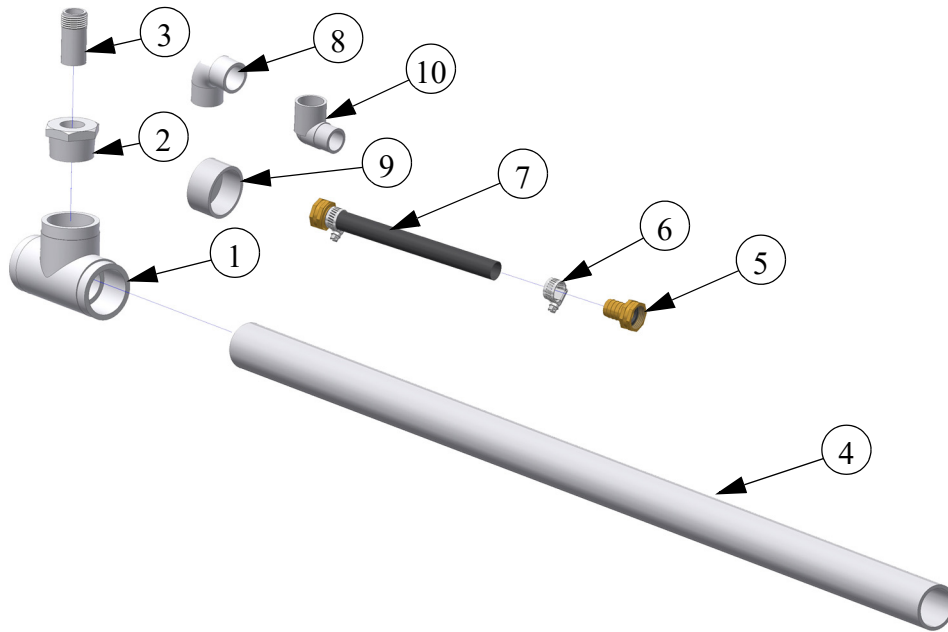

Item	Description	Part No.
1	3/4 PVC sxsxtx Tee	38618
2	Bushing Reducer	36808
3	3/4 Male Adapter	25098
4	1.5 PVC Pipe	38296
5	3/4 Female Swivel Swivel Fitting	50401
6	Hose Clamp	7187
7	3/4" Rubber Hose	47820-50 (50') [15.24m] 47820-100 (100') [30.48m] 47820-200 (200') [30.48m]
8	3/4 PVC Ell	8141
9	1.5" PVC Cap	38498
10	3/4 PVC ST Ell	30138



**Made to work.
Built to last.®**

Revisions to this Manual

Page No.	Description of Change	ECO
various	Shortened up cantilever on waterlines. Added Filter Panel Control installation, Changed to new Regulator Assembly. (Was 42400-11, and -14). Added explanation of cutting pipes at flush end.	32498

Contact your nearby Chore-Time distributor or representative for additional parts and information.

Chore-Time Group
A division of CTB, Inc.
PO Box 2000
Milford, Indiana 46542-2000 USA
Phone (574) 658-4101 Fax (877) 730-8825
E-mail: poultry@choretime.com
Internet: www.choretimepoultry.com