

CHORE-TIME®

Poultry Production Systems

ADVANTI-FLOW®
Poult Nipple Watering System

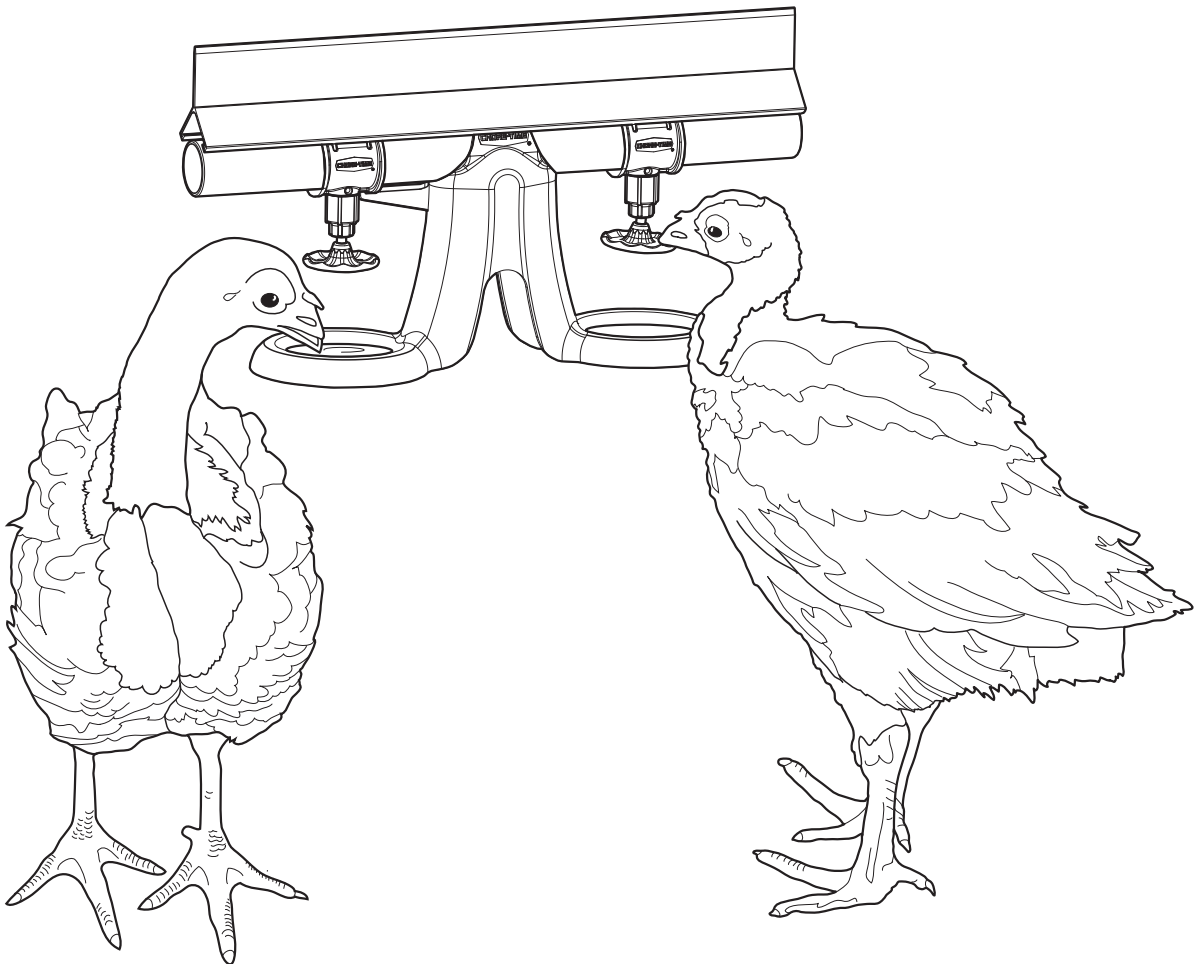

Installation and Operators Manual

Installation and Operators Manual

Warranty

Chore-Time Group, a division of CTB, Inc. (“Chore-Time”) warrants new CHORE-TIME STEDI-FLOW® and RELIA-FLOW® Nipple Drinker products manufactured by Chore-Time to be free from defects in material or workmanship under normal usage and conditions, for One (1) year from the date of installation by the original purchaser (“Warranty”). Chore-Time provides for an extension of the aforementioned Warranty period (“Extended Warranty Period”) with respect to certain Product parts (“Component Part”) as set forth in the table below. If such a defect is determined by Chore-Time to exist within the applicable period, Chore-Time will, at its option, (a) repair the Product or Component Part free of charge, F.O.B. the factory of manufacture or (b) replace the Product or Component Part free of charge, F.O.B. the factory of manufacture. This Warranty is not transferable, and applies only to the original purchaser of the Product.

CONDITIONS AND LIMITATIONS

THIS WARRANTY CONSTITUTES CHORE-TIME’S ENTIRE AND SOLE WARRANTY AND CHORE-TIME EXPRESSLY DISCLAIMS ANY AND ALL OTHER WARRANTIES, INCLUDING, BUT NOT LIMITED TO, EXPRESS AND IMPLIED WARRANTIES, INCLUDING, WITHOUT LIMITATION, WARRANTIES AS TO MERCHANTABILITY OR FITNESS FOR PARTICULAR PURPOSES. CHORE-TIME shall not be liable for any direct, indirect, incidental, consequential or special damages which any purchaser may suffer or claim to suffer as a result of any defect in the Product. Consequential or Special Damages as used herein include, but are not limited to, lost or damaged products or goods, costs of transportation, lost sales, lost orders, lost income, increased overhead, labor and incidental costs, and operational inefficiencies. *Some jurisdictions prohibit limitations on implied warranties and/or the exclusion or limitation of such damages, so these limitations and exclusions may not apply to you. This warranty gives the original purchaser specific legal rights. You may also have other rights based upon your specific jurisdiction.*

Compliance with federal, state and local rules which apply to the location, installation and use of the Product are the responsibility of the original purchaser, and CHORE-TIME shall not be liable for any damages which may result from non-compliance with such rules.

The following circumstances shall render this Warranty void:

- Modifications made to the Product not specifically delineated in the Product manual.
- Product not installed and/or operated in accordance with the instructions published by the CHORE-TIME.
- All components of the Product are not original equipment supplied by CHORE-TIME.
- Product was not purchased from and/or installed by a CHORE-TIME authorized distributor or certified representative.
- Product experienced malfunction or failure resulting from misuse, abuse, mismanagement, negligence, alteration, accident, or lack of proper maintenance, or from lightning strikes, electrical power surges or interruption of electricity.
- Product experienced corrosion, material deterioration and/or equipment malfunction caused by or consistent with the application of chemicals, minerals, sediments or other foreign elements.
- Product was used for any purpose other than for the care of poultry and livestock.

The Warranty and Extended Warranty may only be modified in writing by an officer of CHORE-TIME. CHORE-TIME shall have no obligation or responsibility for any representations or warranties made by or on behalf of any distributor, dealer, agent or certified representative.

Effective: **April 2014**

Chore-Time Group
 A division of CTB, Inc.
 PO Box 2000
 Milford, Indiana 46542-2000 USA
 Phone (574) 658-4101 Fax (877) 730-8825
 E-mail: www.choretimepoultry.com
 Internet: poultry@choretime.com

Contents

Topic	Page
Warranty	2
About This Manual	5
Safety Information	5
Safety Instructions	6
Follow Safety Instructions	6
Decal Descriptions	6
DANGER: Electrical Hazard	6
General	6
Support Information	6
General Information	7
Manufacturer's Recommendations: Birds per Nipple	7
Planning the System layout	8
Preferred Layouts	8
Suspension System Installation	9
Assembling and Hanging the Water Line	11
Cup Installation	11
Suspend Water Lines	12
Install Coupling Assembly	13
Mid-Line Stand Tube	14
Optional Mid-Line Shut-Off Valve:	14
Optional Slope Compensator:	15
Outlet Assembly	15
Regulator Assembly	16
Regulator Operation	16
Filter Control Panel Installation	17
Flushable Filter Control Panel Installation	18
Water Meter Installation	19
Badger® Water Meter Installation	19
Wiring	19
Water Meter Start Up	20
Anti-Roost Installation	21
Installing the Flush System	22
PDS™ Flush Control	23
Parts Listing	24
Filter Control Panel (9275, 9275-1)	24
Step Regulator & Gauge Module Kit (35308)	25
.....	25
Flush able Filter Control Panel	26
Low Pressure: 36802-1	26
High Pressure: 36802-2	26
Stand Tube Outlet Assembly	27
Manual Adjustment VOLUMATIC™ Regulator Assembly (55476-X)	28
Poultry Trainer (44943)	30
Nipple Line Assembly and Components	31

Contents - continued

Topic	Page
Slope Compensator Assembly	32
.	32
Mid Line Shut-Off Kit: 29658	32
.	32
Mid Line Stand Tube Assembly (52273-X)	33
Miscellaneous Kits and Components	34
Miscellaneous Hose Components	34
.	34
Water Medicator	34
Water Meters	34
Mid Line Shut-Off Kit with Flush: 34939-X	35
Suspension System Components:	36
CHORE-TIME ADVANTI-FLOW® Management Guideline	37
Operational Guidelines	38
Management Troubleshooting Guidelines	38
Component Troubleshooting Guidelines	39
Guide to Cleaning Water Lines	40
Standard Cleaning Procedure	40
Regular Maintenance	40
End of Grow Out Cleaning	40
After Administering Vitamins, Medication or other Chemicals	40
Between Flocks	40
Water Quality	41
Hardness	41
Iron	41
Iron Bacteria	41
Acid Water	41
Aggressive/Corrosive Water	41
Taste and Odor	41
Hydrogen Sulfide	41
Sand, Silt or Sediment	41

About This Manual

The intent of this manual is to help you in two ways. One is to follow step-by-step the order of assembly for your product. The other way is for easy reference if you have questions in a particular area.

Important: Read **ALL** instructions carefully before starting construction.

Important: Pay particular attention to all **SAFETY** information.

- *Metric measurements are shown in millimeters and in brackets, unless otherwise specified. “ ” equals inches and “ ’ ” equals feet in English measurements. Examples: 1" [25.4], 4' [1219]*
- Optional equipment contains necessary instructions for assembly or operation.
- Very small numbers near an illustration (*i.e.*, 1257-48) are identification of the graphic, not a part number.

Note: The original, authoritative version of this manual is the English version produced by CTB, Inc. or any of its subsidiaries or divisions, (hereafter collectively referred to as "CTB"). Subsequent changes to any manual made by any third party have not been reviewed nor authenticated by CTB. Such changes may include, but are not limited to, translation into languages other than English, and additions to or deletions from the original content. CTB disclaims responsibility for any and all damages, injuries, warranty claims and/or any other claims associated with such changes, inasmuch as such changes result in content that is different from the authoritative CTB-published English version of the manual. For current product installation and operation information, please contact the customer service and/or technical service departments of the appropriate CTB subsidiary or division. Should you observe any questionable content in any manual, please notify CTB immediately in writing to: CTB Legal Department, P.O. Box 2000, Milford, IN 46542-2000 USA.

Safety Information

Caution, Warning and Danger Decals have been placed on the equipment to warn of potentially dangerous situations. Care should be taken to keep this information intact and easy to read at all times. Replace missing or damaged safety decals immediately.

Using the equipment for purposes other than specified in this manual may cause personal injury and/or damage to the equipment.

Safety–Alert Symbol



This is a safety–alert symbol. When you see this symbol on your equipment, be alert to the potential for personal injury. This equipment is designed to be installed and operated as safely as possible...however, hazards do exist.

Understanding Signal Words

Signal words are used in conjunction with the safety–alert symbol to identify the severity of the warning.



DANGER indicates an imminently hazardous situation which, if not avoided, **WILL** result in death or serious injury.



WARNING indicates a potentially hazardous situation which, if not avoided, **COULD** result in death or serious injury.



CAUTION indicates a hazardous situation which, if not avoided, **MAY** result in minor or moderate injury.

Safety Instructions

Follow Safety Instructions

Carefully read all safety messages in this manual and on your equipment safety signs. Follow recommended precautions and safe operating practices.

Keep safety signs in good condition. Replace missing or damaged safety signs.

Decal Descriptions

DANGER: Electrical Hazard

Disconnect electrical power before inspecting or servicing equipment unless maintenance instructions specifically state otherwise.

Ground all electrical equipment for safety.

All electrical wiring must be done by a qualified electrician in accordance with local and national electric codes.

Ground all non-current carrying metal parts to guard against electrical shock.

With the exception of motor overload protection, electrical disconnects and over current protection are not supplied with the equipment.

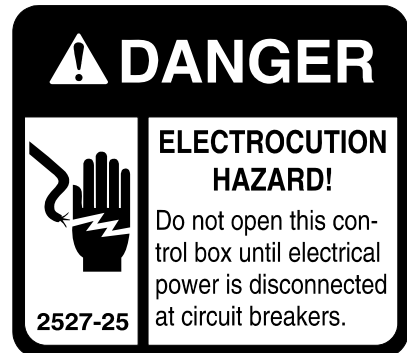

General

Support Information

The Chore-Time Nipple Watering System has been designed to provide water to poultry types. Using this equipment for any other purpose or in a way not within the operating recommendations specified in this manual will void the warranty and may cause personal injury.

This manual is designed to provide comprehensive planning and installation information. The table of contents provides a convenient overview of the information in this manual.

General Information

It is extremely important to maintain good water quality. Good water quality maximizes performance of the equipment, minimizes maintenance and repair, and increases the life of the system. The water should be free of foreign particles.

Pump the well prior to hookup of the system to clear sand, mud, or debris. Chore-Time recommends a water test by a reputable water treatment company in the area. Water treatment and/or extra filtration may be required, depending on the water test results.

Filter Control Panels		Regulators
36802-1	9275/36802-2	All
3-11 psi	11-35 psi*	3-35 psi
For incoming pressure between 35 and 125 psi use the 35308 pressure step down assembly with the filter control panel.		

For every 28" [711 mm] drop in height, water pressure increases one pound. Measure the operating pressure at the water line height.

Incoming water supply should be at least a 1" [25 mm] diameter incoming line (preferably PVC) from a single well. If there are two or more supply wells, the supply line should be larger. Other factors such as, the distance from the well(s) to the filter control panel and other equipment which requires water could demand larger lines.

The suspension system must be correctly installed to insure proper operation of the system. This manual includes the suspension installation information.

The Chore-Time ADVANTI-FLOW® Poults Nipple Drinker is available with nipples spaced six, eight, ten, or twelve on 10' [3 m] see figure 1.

Number of Nipples	Spacing "D"
6	34" [863.6 mm]
8	24" [609.6 mm]
10	18" [457.2 mm]
12	14" [355.6 mm]

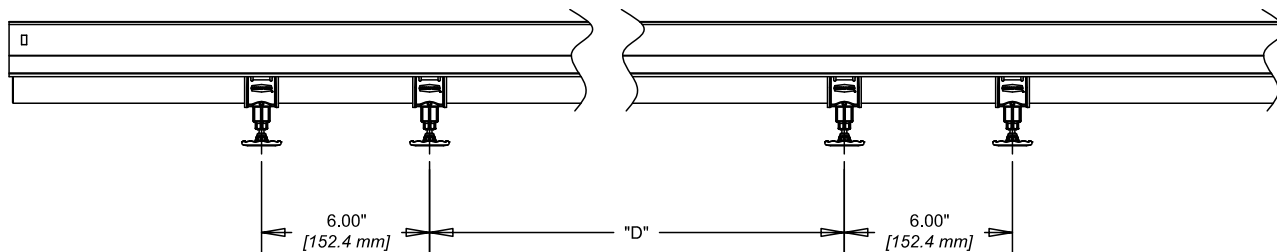

Figure 1. Nipple Spacing

Water lines up to 500' [152 m] may be supplied using (1) inlet assembly. Water lines over 500' [152 m] must be split (typically in the center of the house) and supplied with (2) inlet assemblies. However the management of the lines over 250' [76 m] becomes more critical. They must be kept very level, flushed, and cleaned several times per flock.

Manufacturer's Recommendations: Birds per Nipple

Weeks of Age	Recommended number birds per nipple
0-6	10-16 birds per nipple

Planning the System layout

The diagrams below reflect approved system layouts. Use these diagrams as guidelines. Your system layout may be different.

Preferred Layouts

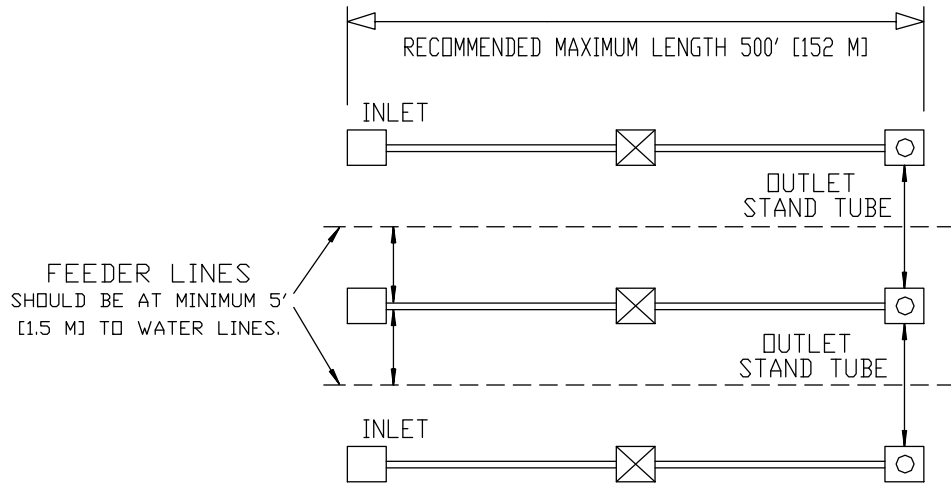

☒ MID LINE AIR REMOVER KIT (NEEDED FOR LINES ABOVE 150' [46 M] LONG)

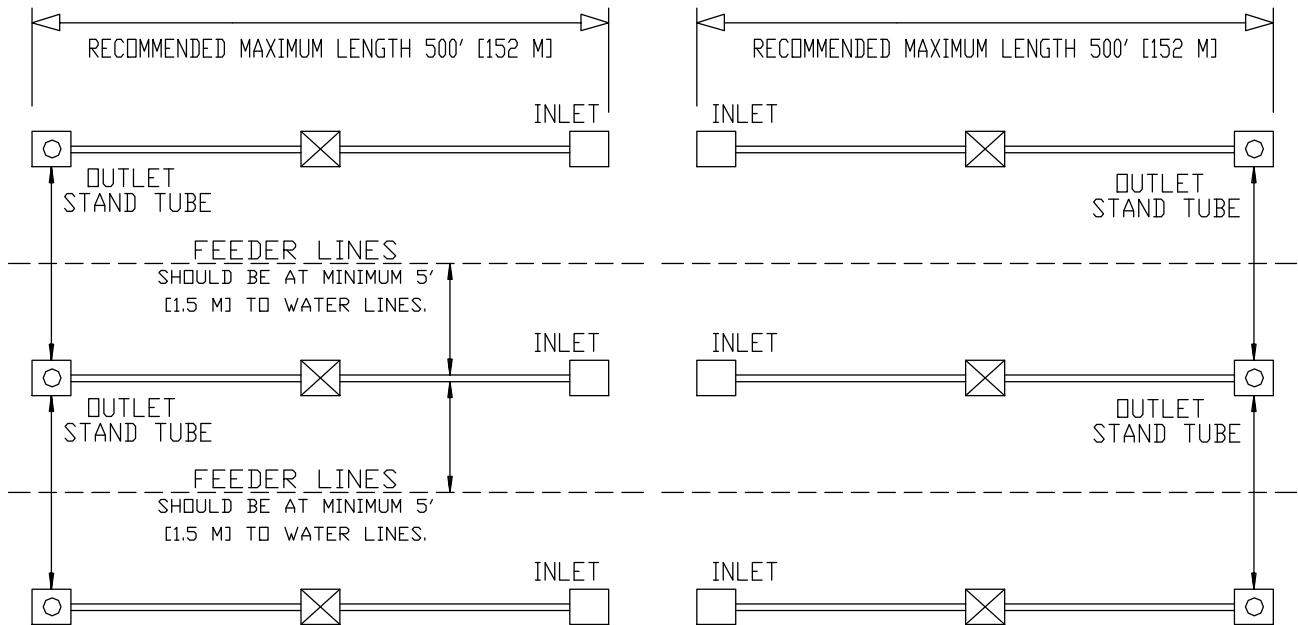

2323-15 4/2008

Suspension System Installation

The following installation instructions are for standard installations.

1. Determine where the water line is to be installed. Mark a straight line on the ceiling or rafters at this point using string or chalk line, or winch cable temporarily attached with staples or nails.
2. For installations using wood trusses, the standard screw hook or the optional ceiling hook may be used to hold the pulley assemblies.

For installations using steel trusses, the ceiling hooks are available to hold the pulley assemblies.

Screw hook installations: Install screw hooks along the line at 8' [2.4 m] or 10' [3 m] intervals.

Screw the threads all the way in to prevent bending. The opening of the hooks must point away from the direction the cable pulls. See **Figure 2**

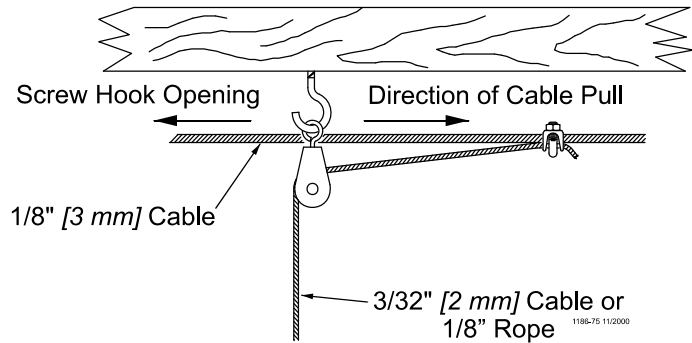

Figure 2. Screw Hook Installation

Ceiling hook installations: Install ceiling hooks along the line at 8' [2.4 m] or 10' [3 m] intervals. If the ceiling hook is to be secured with bolts or self-tapping screws, install as shown in **Figure 3**. The ceiling hooks may be welded in place, if desired, instead of bolting.

Note: If the distance the waterer is to be raised is greater than the distance between the pulleys, offset the pulleys from each other approximately 3" [75 mm].

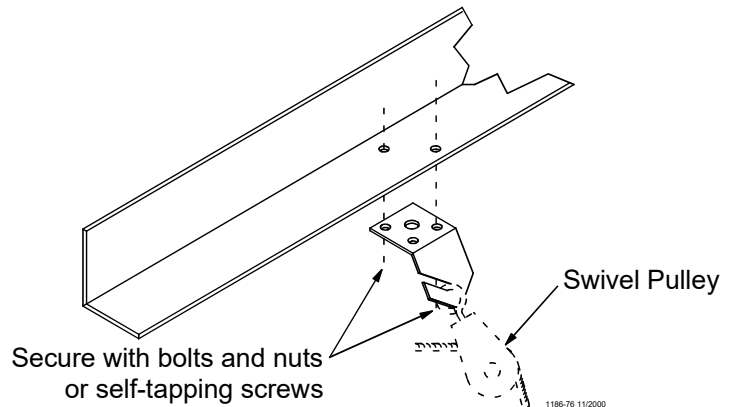

Figure 3. Ceiling Hook Installation

3. After the screw hooks or ceiling hooks have been secured to the trusses, install the pulley assemblies as shown in **Figures 2 & 3**. Make sure the screw hooks or ceiling hooks are pointing in the proper direction (opposite the winch).

4. Mount the split drum winch as shown in **Figure 5**. Mount the winch to the ceiling or on a 2 x 8" [50x200 mm] board spanning at least two rafters for support. Use at least (4) 1/4" lag screws (not supplied) to secure winch to support.

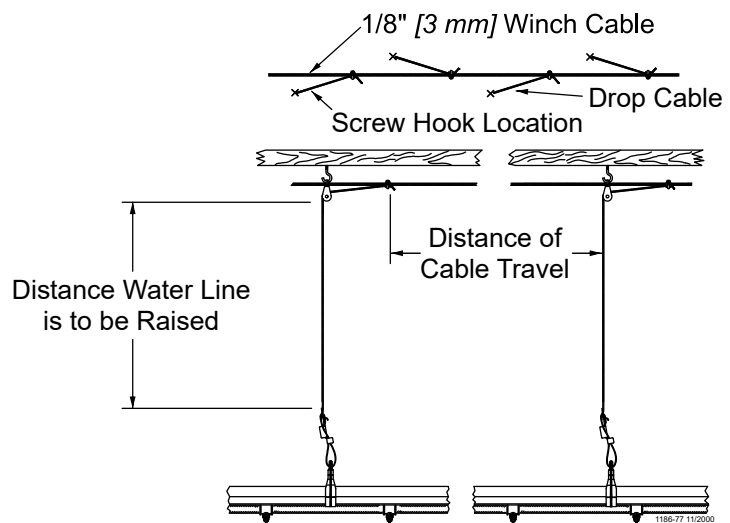

Figure 4. Offset the Screw/Ceiling Hooks

5. Bolt the winch to the bracket, as shown in **Figure 5**.

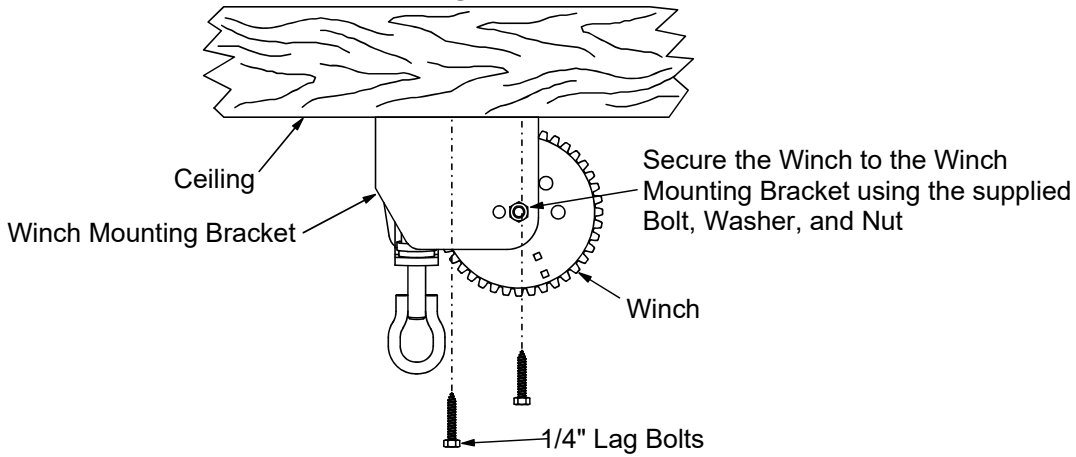

Figure 5. Winch Mounting

6. Attach one end of the 3/16" [4.8 mm] cable to the winch as shown in **Figure 6**. Unroll the cable along the length of the water line.

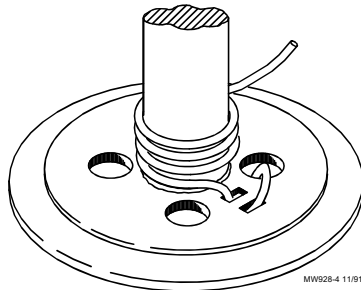

Figure 6. Cable Wrap on Drum

7. Cut a section of the 3/32" [2.3 mm] cable for each suspension drop. The cable should be approximately three feet [91 cm] longer than the distance from the floor to the ceiling so that it can be attached at the top and bottom.

Route the cable around the swivel pulley and attach to the main cable, using a clamp.

Helpful Hint: It may be necessary to fasten a weight to the end of the main cable to maintain tension while connecting the drop lines, etc.

8. Cable drop installations: Install a cable adjustment leveler on each suspension drop. See **Figure 7**.
 Cord drop installations: Install a cord adjustment leveler on each suspension drop. See **Figure 7**.

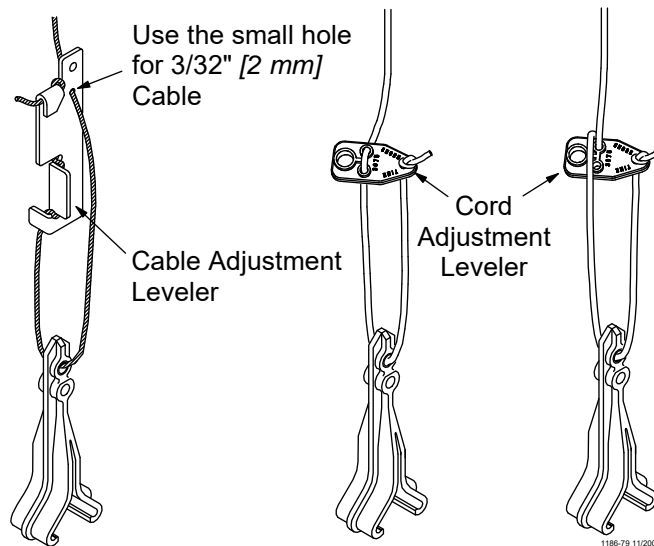

Figure 7. Suspension Drop Installation Options.

Assembling and Hanging the Water Line

Raise the suspension to a convenient working height.

A nail apron may be used to carry suspension hangers, channel connectors, couplers, and cable adjusters.

Figure 8 identifies several of the primary components used with the nipple waterer.

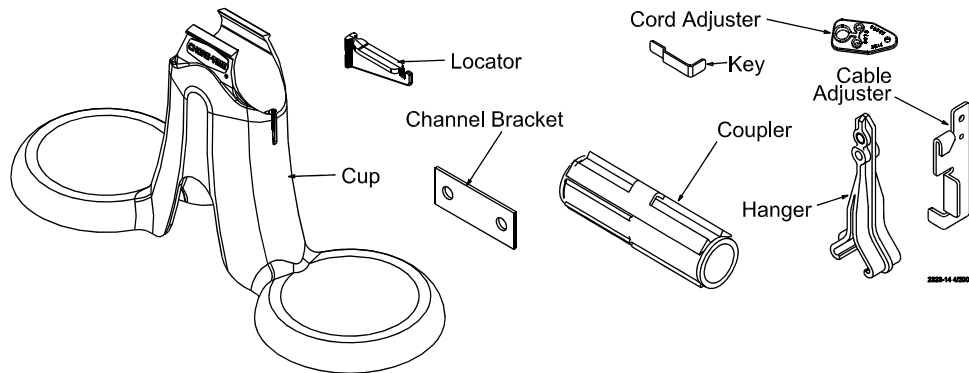

Figure 8. Nipple Waterer Components

Cup Installation

1. Install the locator to the cup as shown, see **figure 9**.

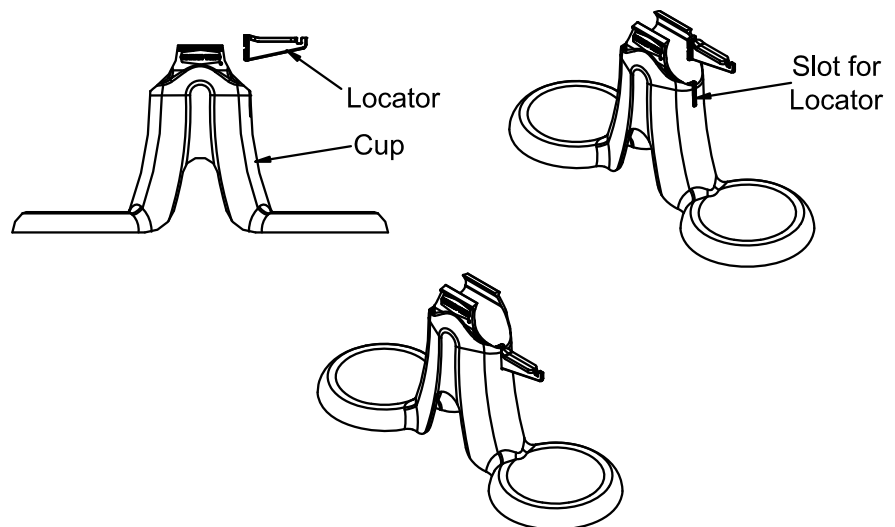

Figure 9. Locator Installation

2. Install cup and locator to the pipe assembly.
3. Turn pipe assembly over and install cup over the water pipe. The cup is to be located between a pair of saddle assemblies, see **figure 10**.

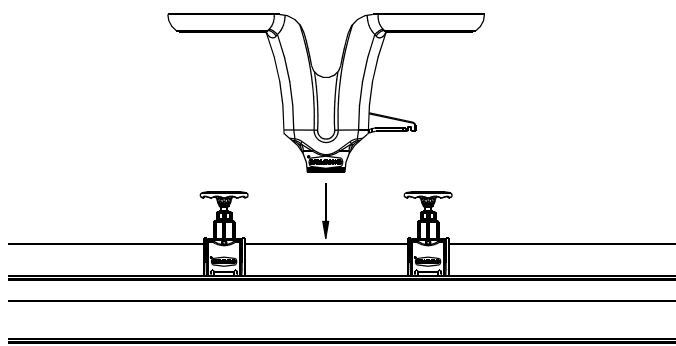

Figure 10. Cup Location

4. Line up slot in locator with rib on the saddle assembly, see **figure 11**.
5. Lock one side of the cup under the channel.

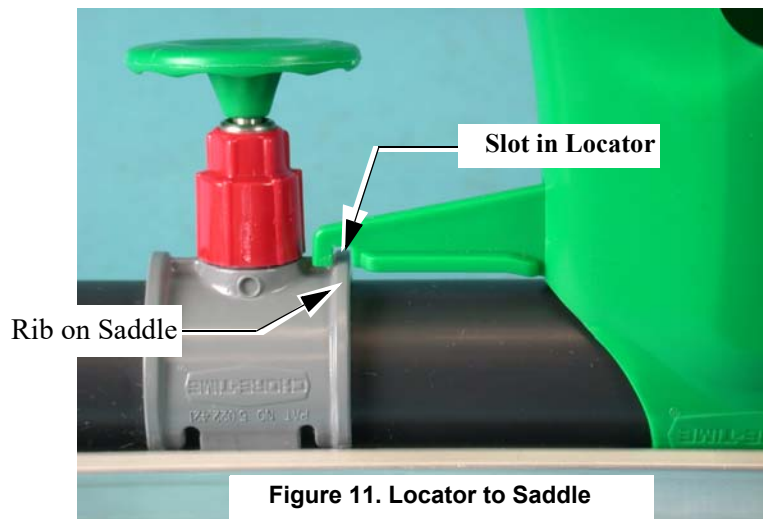

Figure 11. Locator to Saddle

6. Apply pressure to the unlocked side of the cup, see **figure 12**.
7. Rotate cup while applying pressure to the unlocked side of the cup until snapped in place. The cup will now hang straight down and in-line with the nipple assemblies.

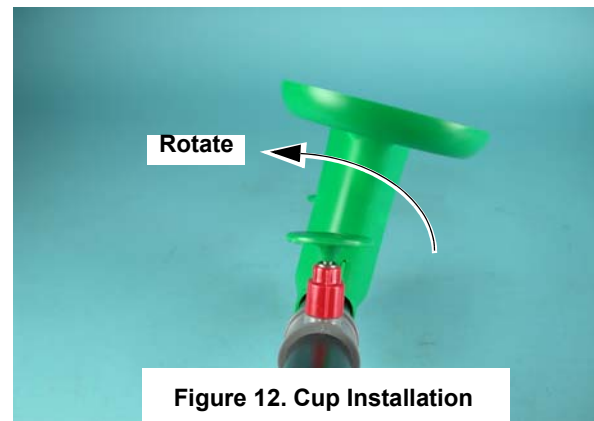

Figure 12. Cup Installation

Suspend Water Lines

Suspend the watering line every 8' [2.4 m] or 10' [3 m] at the suspension drops, as shown **Figure 13**.

1. Route the suspension cable through the top hole of the suspension hanger and around the cable adjuster as shown.
2. Assemble the suspension hanger over the channel at every suspension drop.
3. Additional suspension hangers need to be installed every 2' [610 mm] down the water line. These additional suspension hangers will not be connected to the suspension cable.

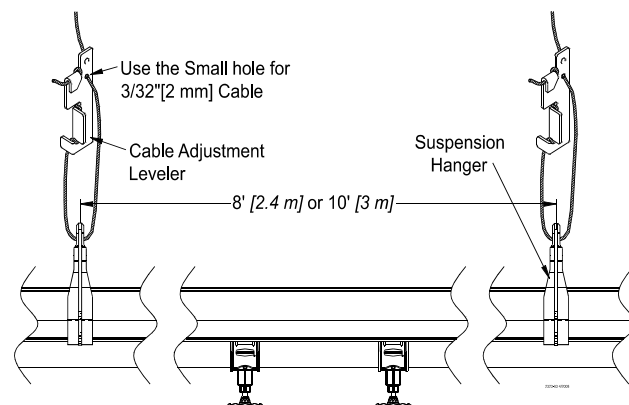

Figure 13. Suspension Hanger Location

Install Coupling Assembly

Install coupling assembly on the end of the water pipe, as shown in **Figure 14**. Insert the pipe until it contacts the stop rib inside the coupler assembly. It may be necessary to lubricate the inside of the coupling to allow for easy installation.

NOTICE

Use only acceptable lubrication as listed below for coupling assembly.

Failure to do so could result in damage to the water line components and will void the manufactures warranty.

Acceptable Lubrication:

- **Plain water or light dish soap and water mixture** may be used to lubricate the inside of the coupling assembly.
- **Silicone oil based Parker Super O-Lube** (available through Chore-Time part number 45911) may be used to lubricate the inside of the coupling assemblies. **Note: Very little (thin film) of this product is needed to provide necessary lubrication.**

Unacceptable Lubrication:

- **DO NOT use petroleum based Parker O-Lube Product!** Only the Parker Silicone oil based Parker Super O-Lube is acceptable.
- **DO NOT use silicone spray!** These may have petroleum based properties that may damage water line components.
- **DO NOT use any petroleum based product!** This would include, but is not limited to, items such as Vaseline, WD40, motor oil, etc.
- **DO NOT use vegetable or any other similar oil!** This would include, but is not limited to, sunflower oil, peanut oil, coconut oil, linseed oil, corn oil, etc.

Insert the next pipe into the other end of the coupler assembly until the support channels meet.

Make sure the water pipes are fully inserted into the coupling assembly.

Note: The support channels will be butted against each other when the coupling is properly installed.

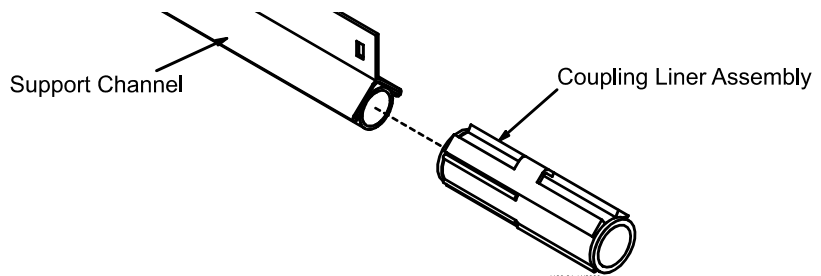

Figure 14. Coupling Assembly Installation

Loosely attach the channel bracket with the supplied 10-24 screw and 10-24 kep nuts to the support channel, as shown in **Figure 15**. Connect the second screw through the channel bracket into the second support channel. Once installed, tighten screws and nuts. This will prevent the water lines from separating at the joints.

If a key will be used for installation, insert the key into the first support channel, as shown in **Figure 15**. Insert the tab of the key through the hole in the second channel support. Once installed, bend the tab to secure in place. This will prevent the water lines from separating at the joints.

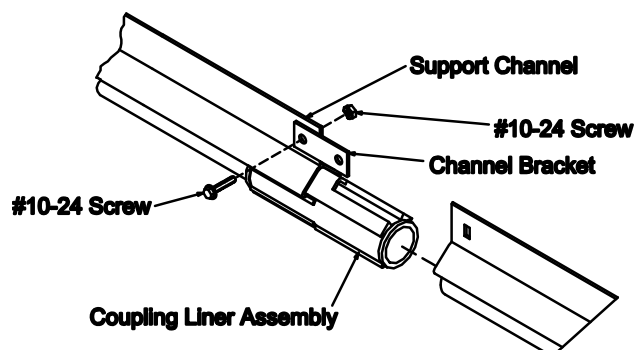

Figure 15. Securing the Water Line together Assembly Installation

Mid-Line Stand Tube

One mid-line stand tube is required for every 150' [46 m] of nipple water line. See **Figure 16**.

1. Insert the water pipe into the body.
2. The support channel will slide into the channels on top of the body.
3. The support channel should then be assembled to the support bracket with the supplied 10-24 stainless steel screw and lock nut.

Repeat this procedure on the opposite side of the Mid-Line Stand Tube Kit.

Optional Mid-Line Shut-Off Valve:

The mid-line shut-off valve may be located at any convenient location along the water line, except next to a joint.

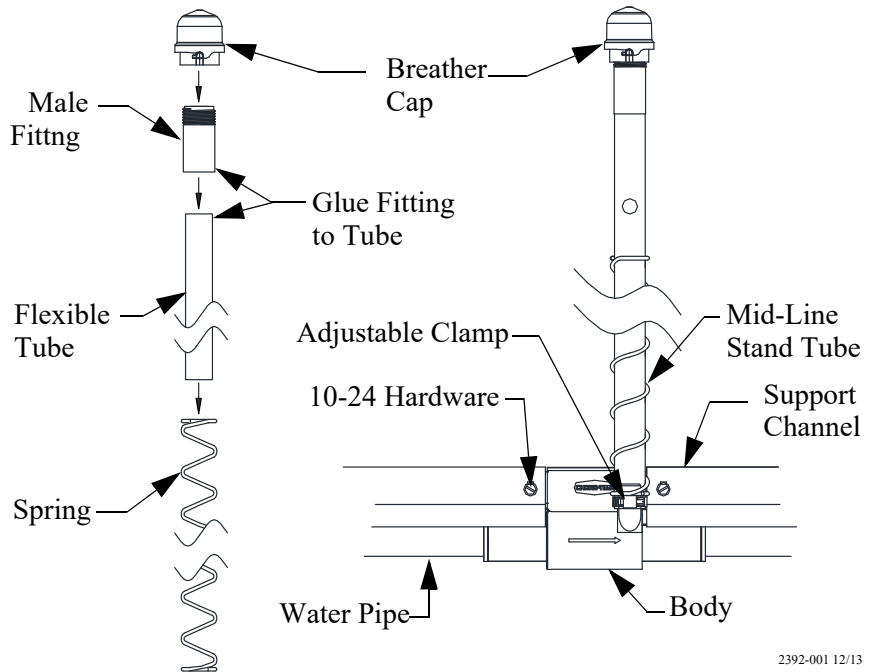

Figure 16. Mid-Line Stand Tube Installation

2392-001 12/13

1. Determine the desired location for the mid-line shut off valve.
2. Use a flat screwdriver to carefully pry 3 or 4 saddles away from the support channel. This will allow easy access to the water pipe for cutting.
3. Use PVC pipe cutters to cut a section out of the water pipe, **see figure 17**. The shut-off valve may be used as a template to determine the required size of the cut.
4. Apply PVC cement to the couplers on the mid-line shut-off valve assembly.
5. Install the mid-line shut-off valve on the water line.
6. Reinstall the saddles, previously loosened, in the support channel.

Note: Chore-Time recommends installing a mid-line stand tube at the first joint before a mid-line shut-off valve to insure proper air removal from the water line

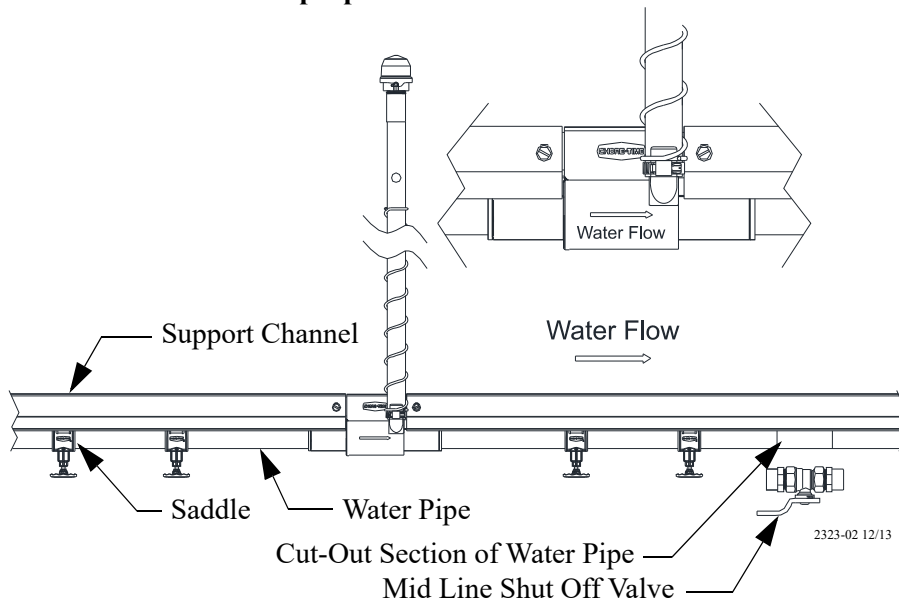

Figure 17. Mid-Line Shut-Off Valve Installation

2323-02 12/13

Optional Slope Compensator:

The slope compensator is used in houses that have a gradual slope over the length of the system. The slope compensator allows the water pressure to be re-adjusted along the line.

- The inlet end of the slope compensator must be at the top of the slope.
- The arrow must point in the direction of water flow. Do not attempt to push water uphill.
- The maximum amount of drop between the inlet assembly and the slope compensator, between two slope compensators, or between the slope compensator and the outlet assembly is 4 inches [100 mm], see figure 18.
- The maximum number of slope compensators to be used on any one water line is six.
- The maximum amount of slope over any water line is 28 inches [71 cm] of drop, see figure 18.

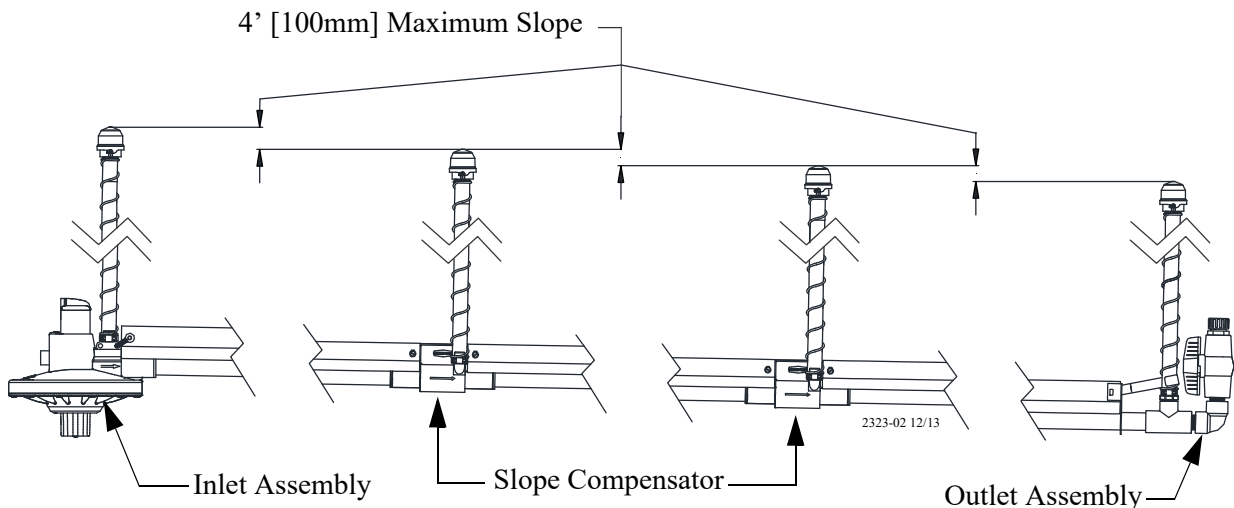

Figure 18. Slope Compensator Assembly Installation

Outlet Assembly

The outlet end must be located within 6" [152 mm] of a suspension drop line. This may require adding an additional suspension drop line or cutting the last section of water line to stop within 6" [152 mm] of an existing drop line.

Before installing the outlet assembly, make sure the end of the water pipe is flush with the end of the support channel. Install the outlet assembly as shown in Figure 19.

If the water line was shortened to terminate under a suspension drop line, it may be necessary to drill a hole in the support channel for the 10-24 truss head screw and lock nut. The hanger may be used as a template to determine proper hole location.

Assemble the stand tube and clamp to the stand tube outlet by sliding the tube over the barbs and tightening the hose clamp. Now push and twist the stand tube spring over the tube and barbs.

DO NOT USE LUBRICANT, ONLY USE WATER TO EASE STAND TUBE INSTALLATION.

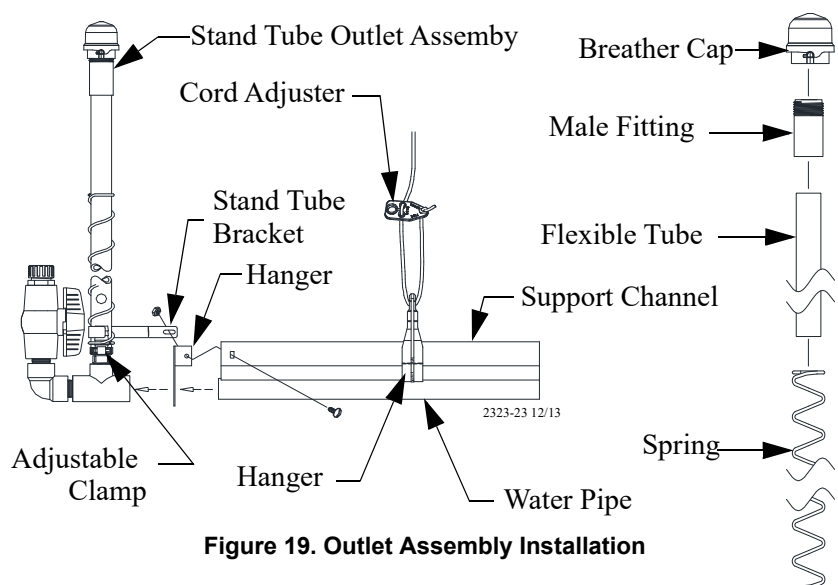

Figure 19. Outlet Assembly Installation

Regulator Assembly

Assemble and install the regulator assembly, as shown in **Figure 20**.

1. Glue the included NH male adapter fitting or optional street ell and NH male adapter fitting to the inlet. **Be careful not to get glue inside the inlet.**
2. Slide the outlet end of the regulator over the watering pipe, **it helps to wet the black outlet liner**, and into the end of the channel.
3. Slide the regulator bracket into the hole provided in the channel with the included #10-24 x 5/8" hex washer head screw and #10-24 hex nut.
4. Assemble the stand tube and clamp to the stand tube outlet by sliding the tube over the barbs and tightening the hose clamp. Now push and twist the stand tube spring over the tube and barbs. **DO NOT USE LUBRICANT!**

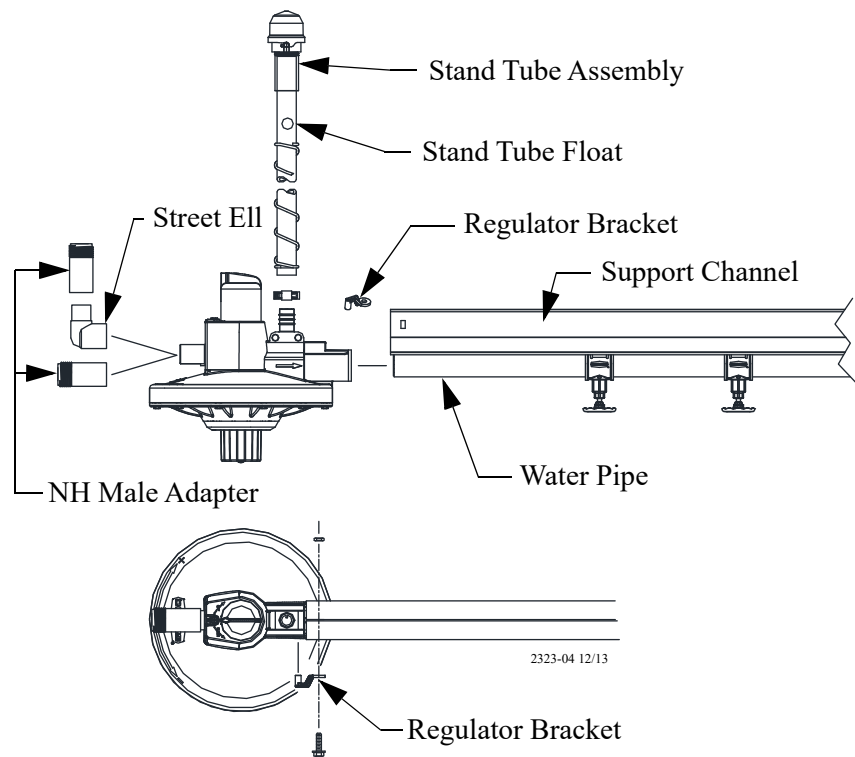

Figure 20. Regulator Assembly Components

DO NOT USE LUBRICANT, ONLY USE WATER TO EASE STAND TUBE INSTALLATION.

Regulator Operation

The VOLUMATIC™ Water Regulator can be shut off by turning the Selector Knob clockwise until it stops. To turn on the regulator, turn the selector knob until it points to the ON position indicated on the regulator. To activate the Flush mode turn the selector knob fully counter-clockwise until it stops.

Regulator Guidelines

Optimum incoming static pressure is 25 - 35 psi [172 - 241 kPa]. The VOLUMATIC Water Regulator can operate at pressures as high as 50 psi [345 kPa] however the life of the regulator seat and diaphragm will be shortened. Also, the supply hose must be of high quality and rated for the increased pressure.

When flushing, make sure the outlet line is clear of restrictions. Excessive back pressure can damage the regulator.

When using the manual adjustment version of the regulator, the water column is set by turning the manual adjustment knob on the bottom of the regulator in the direction shown on the regulator.

Adjust the operating pressure as recommended in the “CHORE-TIME ADVANTI-FLOW® Management Guideline” on page 37.

Important: When increasing the water column, as soon as resistance is noticed, stop turning the manual adjustment knob or damage will occur.

Filter Control Panel Installation

The filter control panel is used to remove foreign material from the incoming water, and, if necessary, add medication to the water.

The step down regulator and gauge assembly is used to reduce the water pressure supplying the filter control panel.

The filter control panel and step down regulator should be installed in a convenient location where incoming and outgoing water supply lines can be easily run. The control panel must be out of the reach of birds.

The filter control panel is shipped secured to a mounting board. The mounting board and filter control panel should be secured to wall or post using lag bolts (not supplied).

The step down regulator and gauge assembly is shipped un-assembled. Assemble the step down regulator and gauge assembly components as specified in the instruction (MW1052) shipped with the kit.

Connect the step down regulator and gauge assembly to the filter control panel, as shown in **Figure .**

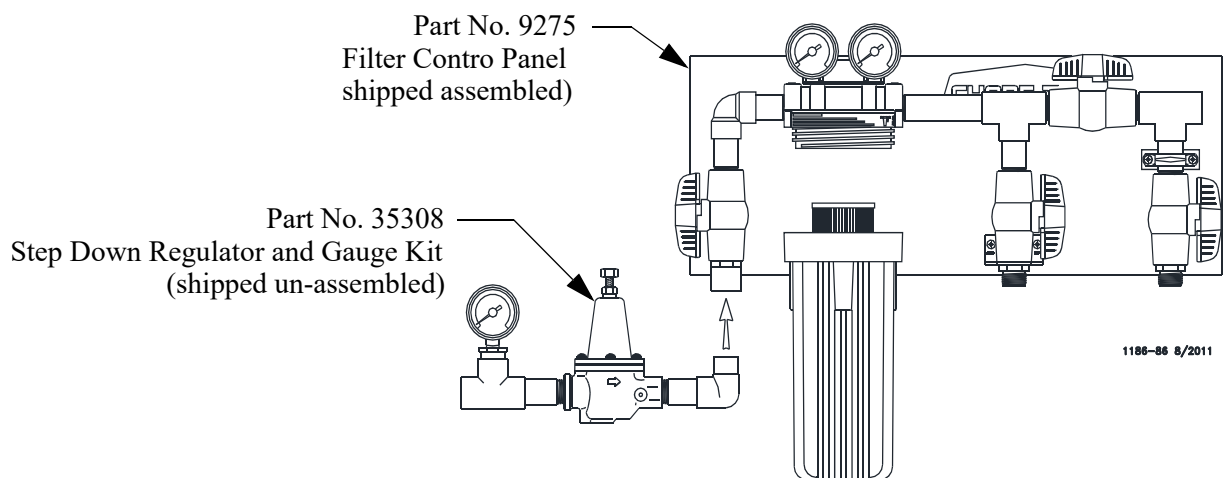

Figure 21. 9275 Control Panel

Flushable Filter Control Panel Installation

(optional alternative to the standard Filter Control Panel)

The flushable filter control panel is used to remove foreign material from the incoming water, and, if necessary, add medication to the water. This control panel features a filter that may be flushed, removed, cleaned, then reinstalled.

Two versions of the filter control panel are available.

The low pressure version is designed to accommodate gravity flow systems with 3 - 10 psi [20.68 - 68.95 kPa]. Do not exceed 15 psi [103.42 kPa] with this control panel, or damage will occur to the gauges.

Systems with 11+ psi [75.84+ kPa] should use the high pressure control panel. For systems above 35 psi, order a step down regulator.

The filter control panel should be installed in a convenient location where incoming and outgoing water supply lines can be easily run. The control panel must be out of the reach of birds.

The filter control panel is shipped secured to a mounting board. The mounting board and filter control panel should be secured to wall or post using lag bolts (not supplied).

The gauge assembly is shipped un-assembled. Assemble the gauge assembly components as specified in the instruction (MW1052) shipped with the kit.

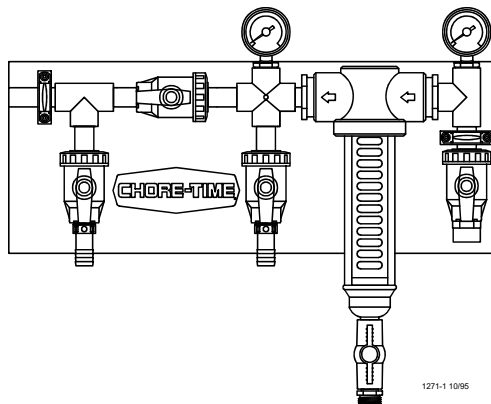

Low Pressure Control Panel
Part Number 36802-1
(3-10 psi [20.68 - 68.95 kPa])

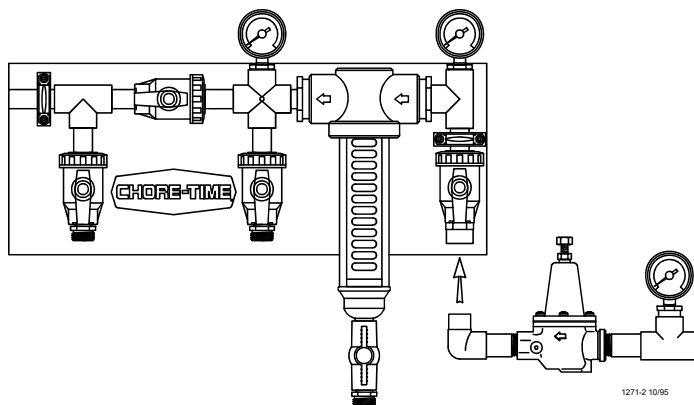

High Pressure Control Panel
Part Number 36802-2

Water Meter Installation

If using an Amco/ABB brand Water Meter, they are not polar sensitive. Therefore: when wiring a Amco/ABB Water Meter, the wire color does not matter.

Badger® Water Meter Installation

Wiring

The Badger® water meter is supplied with 10 ft. (3.05 m) of cable with red and black leads with stripped ends. When connecting to a Chore-Tronics® control, proper polarity must be maintained. The red lead is connected to the DI (digital input) of your choice, and the black lead is connected to the ground terminal of the chosen DI

Chore-Tronics™ Control
D1 of your choice



Figure 22. Water Meter Wiring

Mounting

The Badger® Water Meter must be installed with the Cap up as shown below. Refer to the Badger® installation manual for more information.

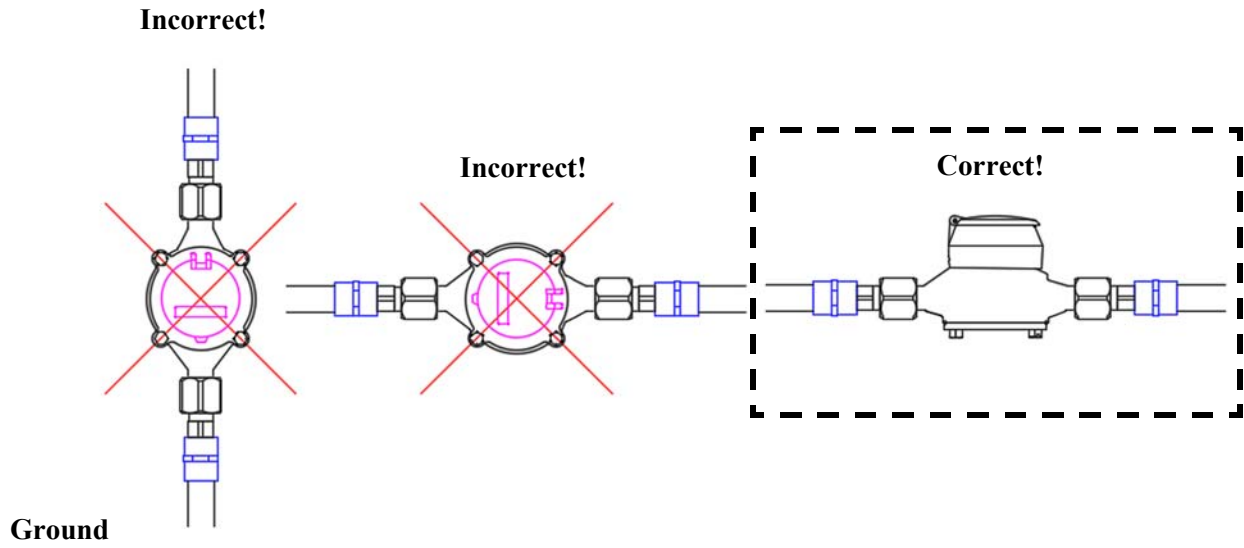

Figure 23. Water Meter Mounting

Water Meter Start Up

Attention! Air and debris in the supply line upstream of the meter installation must be removed before pressurizing the meter with water or damage to the meter is likely!

If the Water Meter is located very close to the Filter Panel- Valves #1 and #2 can be opened to remove any air and debris from the upstream piping to the inlet point of the Meter. After flushing, valve #2 can be closed and the Meter can be installed. Once installed, valve #2 must be opened **very slowly** to fill the downstream line and pressurize the Meter without damaging it.

If the water meter is not located very close to the Filter Panel- another optional valve can be installed close to the Meter. Before installing the meter, valves #1, #2 and the Optional valve can be opened to remove any air and debris from the upstream piping to the inlet point of the Meter. After flushing, the Optional valve can be closed and the Meter can be installed. Once the Meter is installed the Optional valve must be opened **very slowly** to fill the downstream line and pressurize the Meter without damaging it.

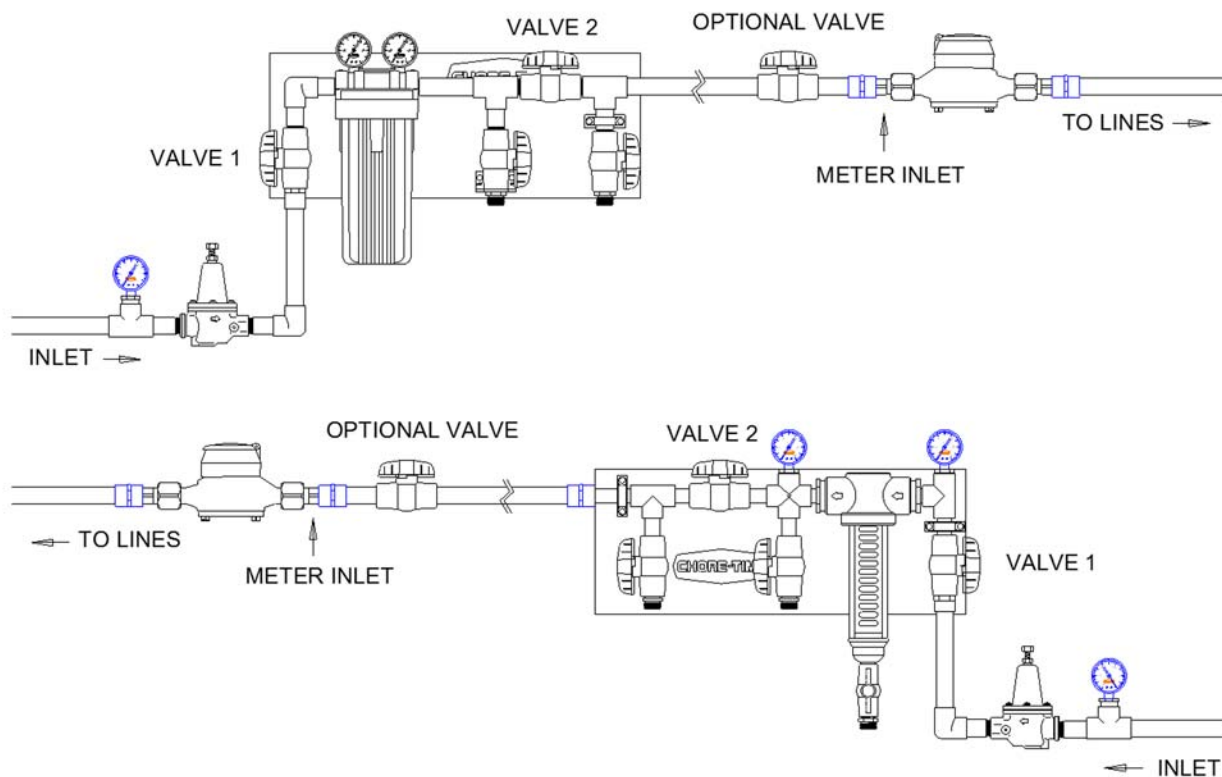

Figure 24. Water Meter Start Up

Anti-Roost Installation

The anti-roost system prevents the birds from setting on the water line. **Figure 25** shows an overview of the anti-roost system.

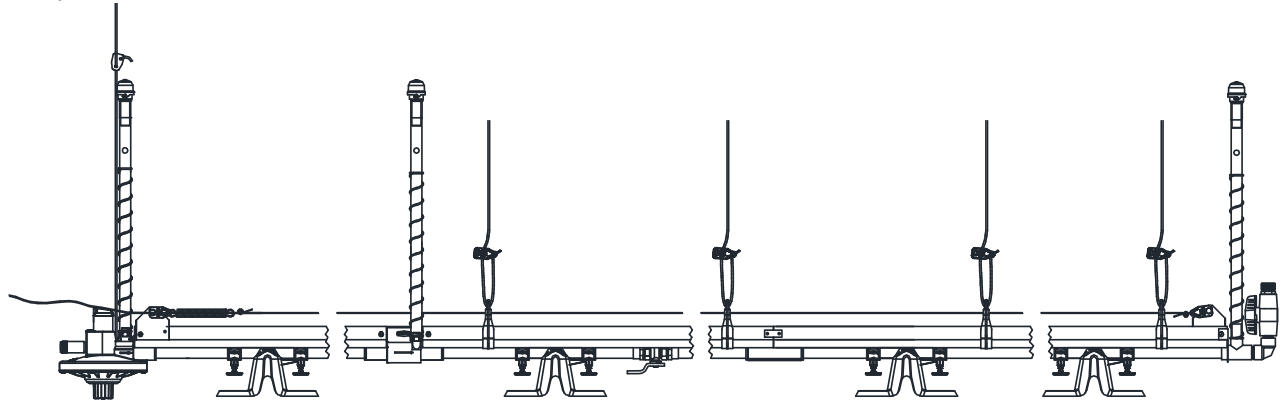

Figure 25. Regulator End Components

2323-05 12/13

1. Make certain that an anchor plate with adjustment leveler is installed at the beginning and end of each anti-roost line. See **Figure 26**.
2. When an anti-roost system is to be installed the channel bracket must be used in place of the key to connect the channels together.
3. Install a suspension hanger every 24" [610 mm]
4. Beginning at the first suspension hanger, thread the training cable the full length of the anti-roost line. Allow approximately 24" [610 mm] extra and cut the cable.
5. Create a small loop with the cable and a cable clamp.
6. Connect the cable loop to the adjustment leveler/anchor plate.
7. Install a spring on the adjustment leveler/anchor plate near the inlet assembly.
8. Pull the cable taught and create a small loop with the cable and a cable clamp.
9. Connect the cable to the spring.
10. The spring should be stretched to an overall length of approximately 8" [203 mm]. Adjust as required.
11. Repeat the above procedure on each of the anti-roost lines.

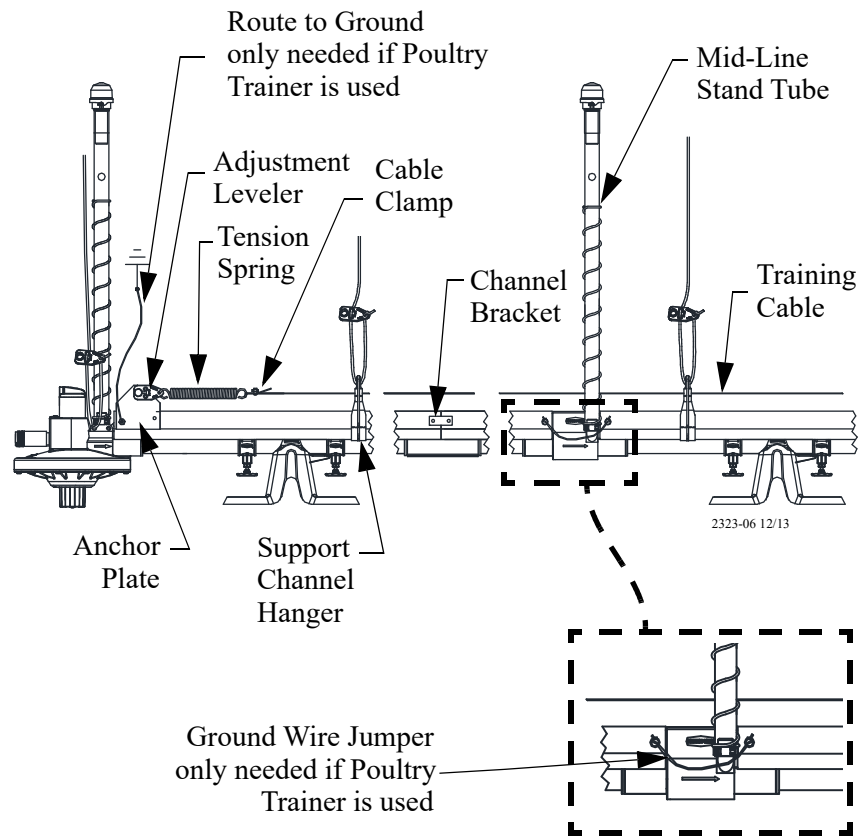

Figure 26. Anti-Roost Components

2323-06 12/13

12. **Optional Equipment:** Secure the poultry trainer to a wall or post near the water line. Chore-Time recommends wiring the poultry trainer into separate electrical circuit that can be switched at the door. Refer to the instructions supplied with the poultry trainer for wiring information. Note: Make sure that the support channel is attached to a ground (to insure proper operation of the poultry trainer). Also when mid-line stand tubes are used a jumper wire will need to be installed to continue electrical current. See **Figure 26**.

Installing the Flush System

The flush system provides convenient one-man system purging.

Chore-Time recommends flushing one line at a time to maximize the cleaning in each line.

The hose, PVC pipe and connections must be purchased locally.

Install the flush components as shown in **Figure 27**.

1. Notice that the exit line must exit through the building wall at a minimum height of 72" [182.8 cm] above floor level.

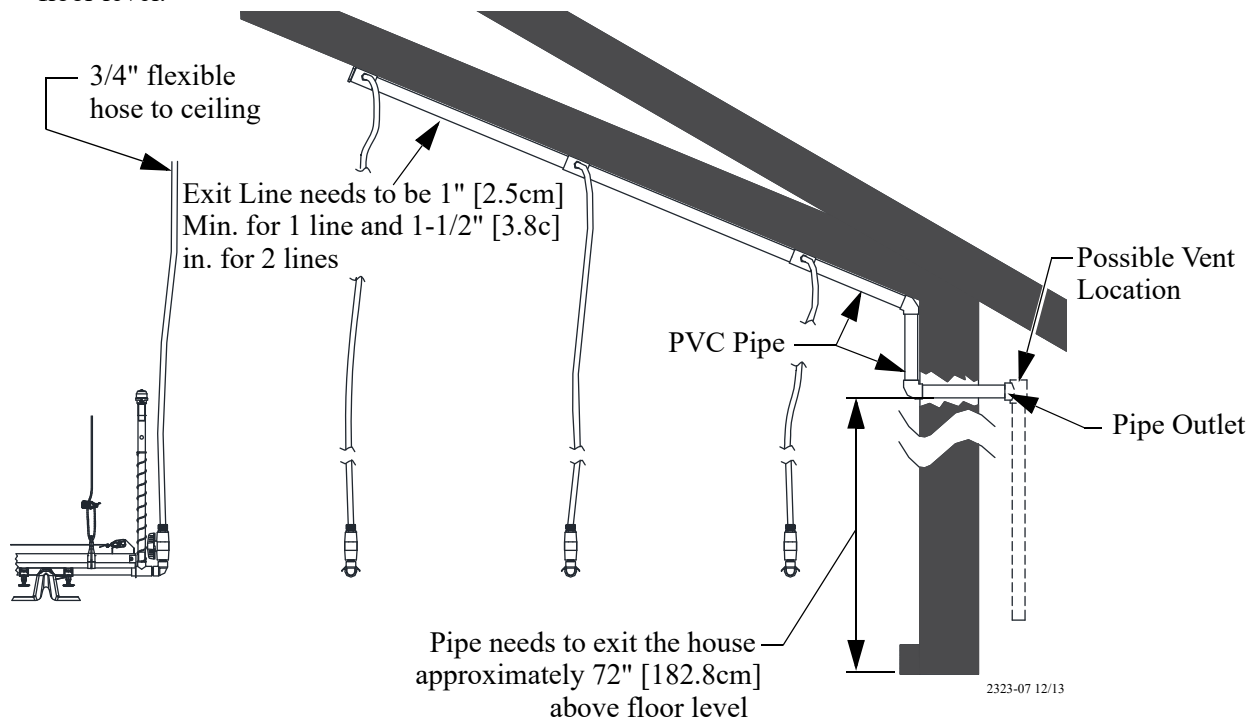

Figure 27. Anti-Roost Components

2. The exit line needs to be 1" [2.5 cm] minimum for 1 flushing line. To connect multiple flushing lines together (as shown) the exit line needs to be 1 1/2" [3.8 cm] minimum for 2 flushing lines.
3. The exit line should be attached to the ceiling of the house and must exit out the side wall of the house. This line needs to be at an adequate height to allow clearance for any equipment used in the house. It may be necessary to route the exit line out both sides of the house to ensure water leaves the exit line.
4. Measure and cut the plumbing to the required lengths for your individual system.
5. The hose attached to the end of the watering line that extends up to the exit line is to be made of a flexible material.

Note: A siphon will be created during flush if the PVC pipe outlet is at or below the level of the top of the stand tube in the house at grow-out.

If it is not possible to have the pipe outlet above the top of the stand tube a vent must be installed. The vent must be above the top of the stand tube at all times during operation of the watering system.

Caution! When flushing, the nipple line outlets must be free of any restriction such as kinked hose, closed outlet valve, etc. Obstructions will result in excessive back pressure which can damage the regulators and other water line components.

PDS™ Flush Control

Optional PDS™ (Pneumatic Drinking System) controls can be used with Chore-Time regulators as an option to the standard manual flush regulators.

PDS controls are programmable controls which can provide automatic flushing cycles. These controls also provide a central place to flush watering lines along with pressure adjustment which regulates the water column height.



4-8 station PDS control



12-40 station PDS control

The PDS control is available in station increments of 4 (ie. 12, 16, 20...). Each station is capable of controlling up to 2 individual Chore-Time regulators. For example a 12 station control can regulate and flush up to 24 individual regulators.

Available control part numbers:

Part Number	Number of stations
52430-4	4
52430-8	8
52430-12	12
52430-16	16
52430-20	20
52430-24	24
52430-28	28
52430-32	32
52430-36	36
52430-40	40

Parts Listing

Filter Control Panel (9275, 9275-1)

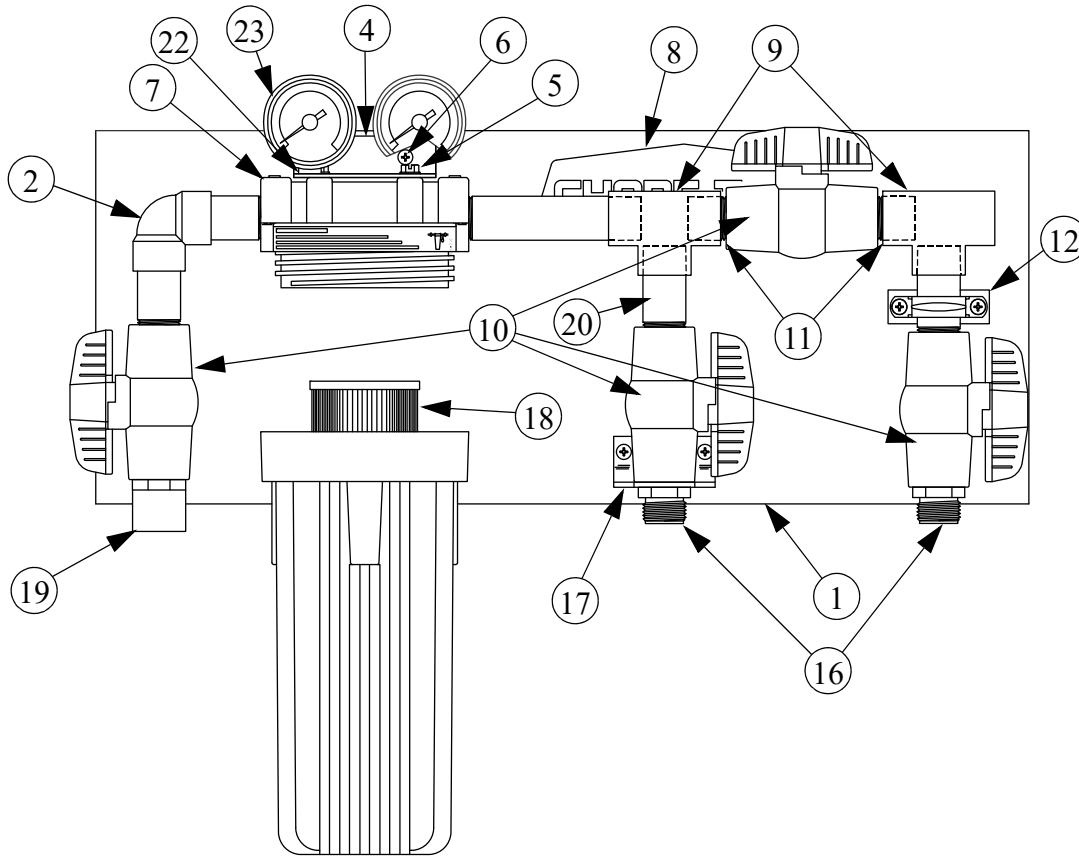

		9275	9275-1
Item	Description	Part No.	
1	Mounting Board	35303	35303
2	3/4" PVC Ell	8141	8141
4	Filter Mounting Bracket	35302	35302
5	1/4-14 x 3/4 Sheet Metal Screw	35425	35425
6	#10-13 x 5/8 Phil Screw	35423	35423
7	Water Filter with Gauge Ports	35309	35309-1
8	Chore Time Decal	2525-4	2525-4
9	3/4" PVC Tee	7538	7538
10	3/4" Quarter Turn Valve	35781	35781
11	3/4 x 1.44 PVC Nipple	7531	7531
12	Standoff Block	35300	35300
14	Plastic Conduit Clamp	35301	35301
16	3/4" Nylon Adapter	7543	7543
17	Medicator Connector Brace	35307	35307
18	20 Micron Filter Cartridge (Standard)	7723	7723
	10 Micron Filter Cartridge (Optional)	13145	13145
19	3/4 PVC Adapter	9229	9229
20	3/4 x 2.50 PVC Nipple	7531-9	7531-9
21	3/4 x 5" PVC Nipple	7531-11	7531-11
22	3/4" Thrd. Adapter	7702	7702
23	High Press. Water Gauge	7191	7191

Step Regulator & Gauge Module Kit (35308)

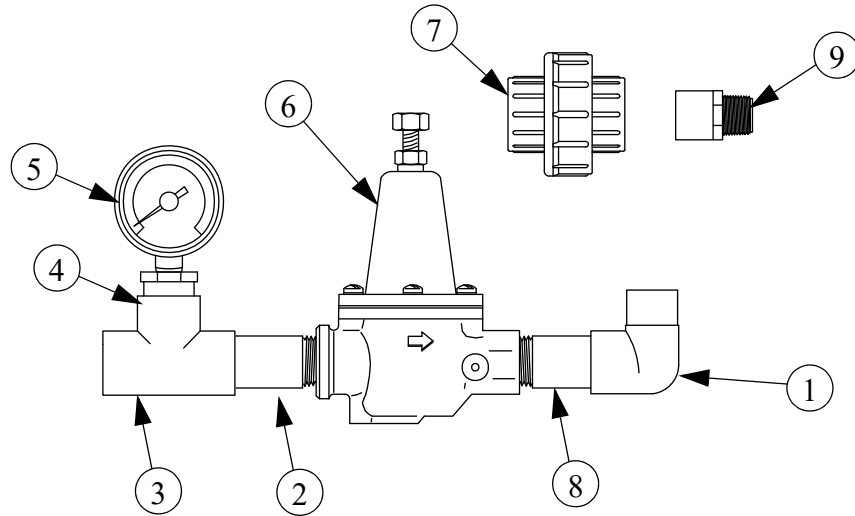

Item	Description	Part No.
1	3/4" PVC Street Ell	30138
2	3/4" x 3" Threaded PVC Nipple	7531-1
3	3/4" PVC Tee	7538
4	3/4 x 1/4 Reducer Bushing	7789
5	High Press. Water Gauge	7191
6	Regulator	29951
7	3/4 PVC Union	8137
8	3/4" x 2.5" Threaded PVC Nipple	7531-9
9	Male PVC Adapter	34100

Flush able Filter Control Panel

Low Pressure: 36802-1

High Pressure: 36802-2

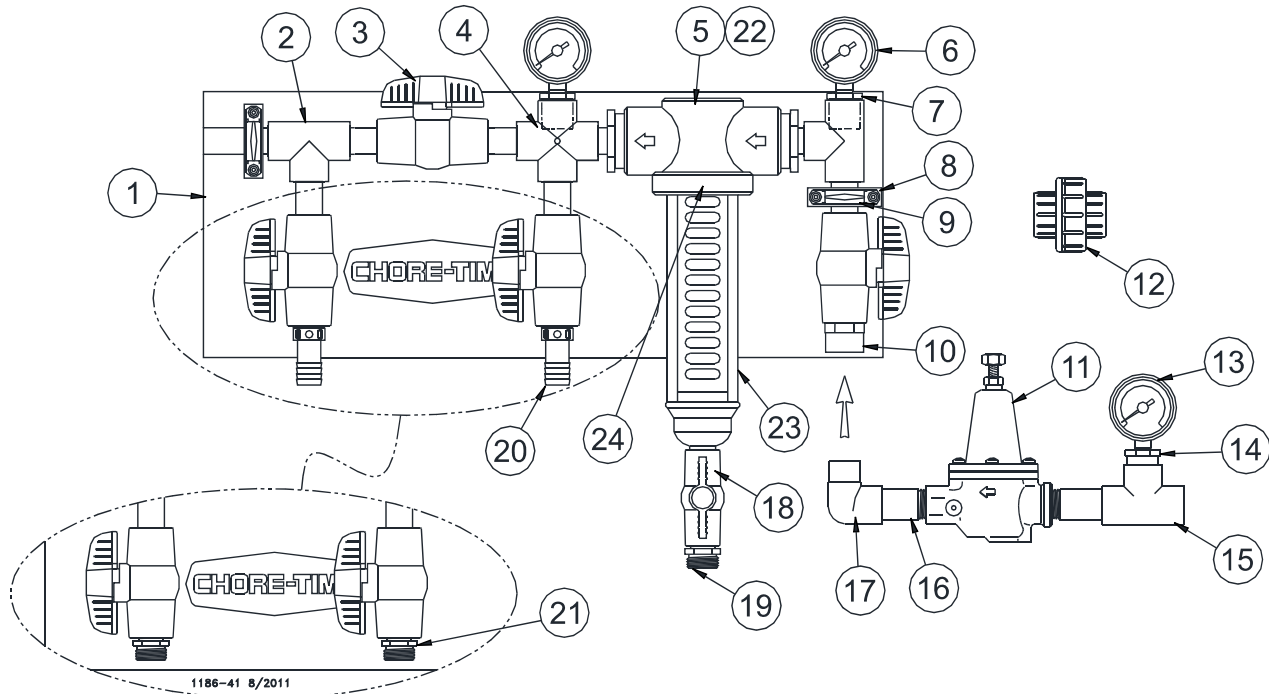

		36802-1	36802-2
Item	Description	Part No	Part No
1	Mounting Board	35303	35303
2	Meditator Outlet Assembly	36805	36805
3	3/4" Valve	35781	35781
4	3/4" Cross	7536	7536
5	Filter Inlet Assembly	36810	36810
6	Pressure Gauge	27722	7191
7	3/4" x 1/4" Reducer Bushing	7789	7789
8	Standoff Block	35300	35300
9	3/4" Plastic Conduit Clamp	35301	35301
10	3/4" PVC Male Adapter	9229	9229
11*	Step Regulator	29951	---
12*	Union	8137	---

		36802-1	36802-2
Item	Description	Part No	Part No
13*	High Pressure Gauge	7191	---
14*	3/4" x 1/4" Reducer Bushing	7789	---
15*	3/4" PVC Tee (S x S x S)	7538	---
16	3/4" Threaded PVC Nipple	7531-1	---
17	3/4" PVC Street Ell	30138	---
18**	1/2" Ball Valve	34961	34961
19**	Nylon Adapter	29141	29141
20	3/4" Barb x 3/4" Pipe Adapter	27422	---
21	3/4" Male Adapter (Nylon)	---	7543
22	Flush able Filter	36806	36806
23**	Filter Cover	46993	46993
24	O-Ring Kit	36807	36807

*Items not included with the flush able filter control panel. They may be ordered separately as a assembly, Part No. 35308.

**Included with Item 5.

These parts may be ordered separately, if needed.

Description	Part No.
1/2 Pint PVC Cement	6303-3
Replacement 140 Mesh Filter	36809
Flush able Filter Assembly	36810

Stand Tube Outlet Assembly

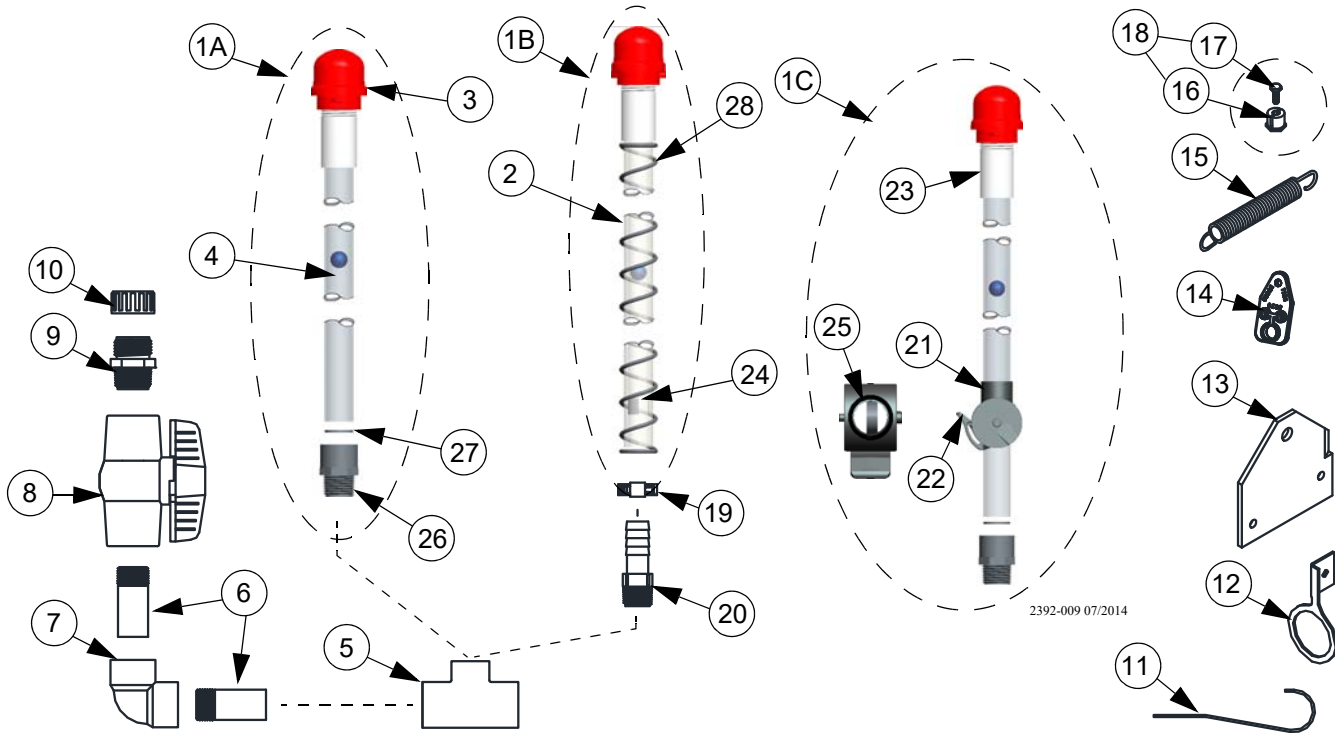

Item	Description	52275-2 Part No	52275-3 Part No	52275-4 Part No	52275-5 Part No	52275-6 Part No	52275-7 Part No
1A	Rigid Stand Tube Assembly	---	---	---	---	54517-3	54517-3
1B*	Flexible Stand Tube Assembly	54517-1	54517-1	---	---	---	---
1C	Folding Stand Tube Assembly	---	---	54517-7	54517-7	---	---
2**	Flexible Tubing	36840-1	36840-1	---	---	---	---
3**	Breather Cap Assembly	54606	54606	54606	54606	54606	54606
4**	Stand Tube Float Ball	37142	37142	37142	37142	37142	37142
5	Reducing Tee	34777	34777	34777	34777	34777	34777
6	3/4 x 2" Threaded PVC Pipe	7531-4	7531-4	7531-4	7531-4	7531-4	7531-4
7	3/4" S x T Ell	7558	7558	7558	7558	7558	7558
8	3/4" Ball Valve	35781	35781	35781	35781	35781	35781
9	3/4" Nylon Adapter	7543	7543	7543	7543	7543	7543
10	Hose Cap (Washer Included)	9811	9811	9811	9811	9811	9811
11	Stand Tube Bracket	33900	33900	33900	33900	33900	33900
12	Hanger	35481	35481	35481	35481	35481	35481
13*	Anchor Plate	---	42807	---	42807	---	42807
14*	Adjustment Leveler	---	3075	---	3075	---	3075
15*	Extension Spring	---	25353	---	25353	---	25353
16*	#10-24 Slotted Nut	---	1840	---	1840	---	1840
17*	#10-24 x 3/8" Machine Screw	---	1951	---	1951	---	1951
18	Cable Clamp	---	1826	---	1826	---	1826
19	Adjustable Clamp	49529	49529	---	---	---	---
20	1/2" Male Adapter	47881	47881	---	---	---	---
21**	Outer Stand Tube Body	---	---	54561	54561	---	---
22**	Inner Stand Tube Body	---	---	54560	54560	---	---
23**	3/4" NH Fitting	25098	25098	25098	25098	25098	25098
24**	Flexible Ball Stop	54590-1	54590-1	---	---	---	---
25**	O-Ring	---	---	52137	52137	---	---
26**	.50 MTXS Male Adapter	---	---	9067	9067	9067	9067
27**	Washer	---	---	2955-44	2955-44	2955-44	2955-44
28**	Spring	36839-1	36839-1	---	---	---	---

* Included in 34531-1 Kit, ** Included in 54517-X Assembly

Manual Adjustment VOLUMATIC™ Regulator Assembly (55476-X)

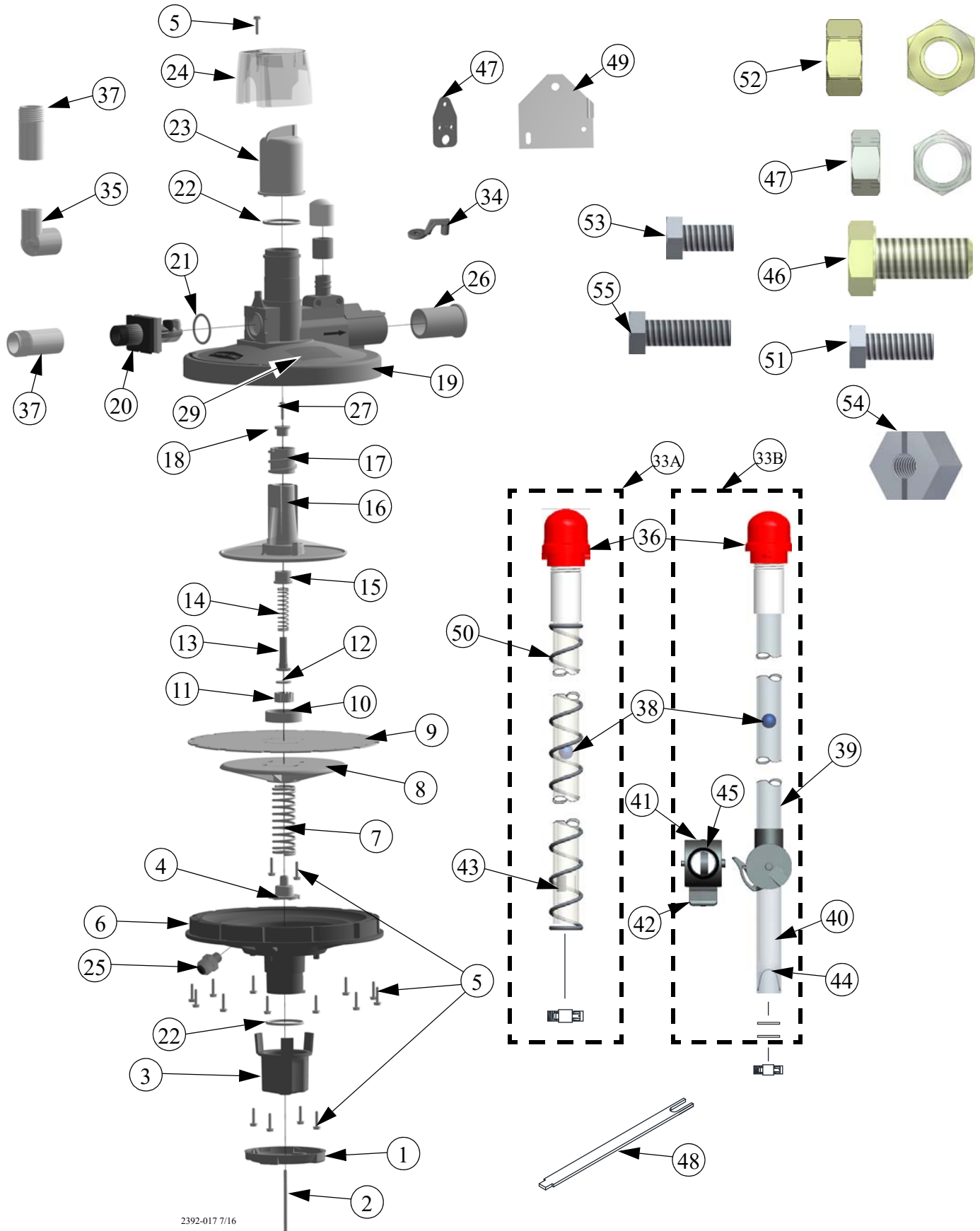

2392-017 7/16

Item	Description	Manual Adjust	Manual Adjust	Manual Adjust	Kit w/Poultry Trainer	Kit w/Poultry Trainer
		No Stand Tube 55476-1	w/ Folding Stand Tube & Anti-Roost 55476-2	w/ Flexible Stand Tube 55476-3	Manual Adjust w/ Folding Stand Tube & Anti-Roost 55476-2T	Manual Adjust w/ Flexible Stand Tube 55476-3T
		Part No.	Part No.	Part No.	Part No.	Part No.
1	Knob Retainer	55477	55477	55477	55477	55477
2	#8-18 x 2-1/2" Screw	42387	42387	42387	42387	42387
3	Adjustment Knob	55478	55478	55478	55478	55478
4	Follower	42183	42183	42183	42183	42183
5	6-20x.625 Screw	44946	44946	44946	44946	44946
6	Bottom Regulator Half	55479	55479	55479	55479	55479
7	.78 x 2.8" Spring	42393	42393	42393	42393	42393
8	Diaphragm Plate	42177	42177	42177	42177	42177
9	Diaphragm	42181	42181	42181	42181	42181
10	Diaphragm Ctr Support	42186	42186	42186	42186	42186
11	Seat Cup	48199	48199	48199	48199	48199
12	Seat	48225	48225	48225	48225	48225
13	Seat Holder	42189	42189	42189	42189	42189
14	.780 x 2.8 Spring	42392	42392	42392	42392	42392
15	Seat Holder Sleeve	42187	42187	42187	42187	42187
16	Diaphragm Plate	42177	42177	42177	42177	42177
17	Bottom Regulator Half	42180	42180	42180	42180	42180
18	Seat Holder Cap	42176	42176	42176	42176	42176
19	Regular Top Half	42174	42174	42174	42174	42174
20	Inlet Orifice	42190	42190	42190	42190	42190
21	O-Ring	29118	29118	29118	29118	29118
22	1.362x.103 O-Ring	42389	42389	42389	42389	42389
23	Selector Knob	42178	42178	42178	42178	42178
24	Shroud	42390	42390	42390	42390	42390
25	1/8 NPTx1/4 Connector	50820	50820	50820	50820	50820
26	Half Liner	36501	36501	36501	36501	36501
27	#6 x .625 Screw	52025	52025	52025	52025	52025
29	Decal	2529-813	2529-813	2529-813	2529-813	2529-813
32	Plug	55837	55837	55837	55837	55837
33A	Flexible St. Tube Assy.	---	---	54517-1	---	54517-1
33B	Folding St. Tube Assy.	---	54517-8	---	54517-8	---
34	Regulator Bracket	44846	44846	44846	44846	44846
35	1/2" Street Elbow	33895	33895	33895	33895	33895
36*	Breather Cap Assembly	---	54606	54606	54606	54606
37*	3/4 NH Fitting	---	25098	25098	25098	25098
38*	1/2" PP Ball	---	37142	37142	37142	37142
39*	Clear PVC Top Piece	---	38250-3	---	38250-3	---
40*	Clear PVC Bottom Piece	---	38250-2	---	38250-2	---
41*	Outer Stand Tube Body	---	54561	---	54561	---
42*	Inner Stand Tube Body	---	54560	---	54560	---
43*	Flexible Ball Stop	---	---	54590-1	---	54590-1
44*	Rigid Ball Stop	---	54817	---	54817	---
45**	O-Ring	---	52137	---	52137	---
46**	5/16-18 x .75 Bolt	---	2046	---	2046	---
47**	5/16-18 Hex Nut	---	2145	---	2145	---
48**	Adjustment Leveler	---	3075	---	3075	---
49**	Anchor Plate	---	42807	---	42807	---
50**	Spring	---	---	36839-1	---	36839-1
51**	10-24 x .50 Screw	---	4416-3	---	4416-3	---
52**	10-24 Nut	---	313	---	313	---
53**	10-24 x .38 Screw	---	1951	---	1951	---
54**	10-24 Slotted Nut	---	1840	---	1840	---
55	10-24 x 5/8 Screw	1876	1876	1876	1876	1876
56	Poultry Trainer (not shown)	---	---	---	44943	44943

*Included in 54517-X Assembly, **Included in 34531-X

Poultry Trainer (44943)

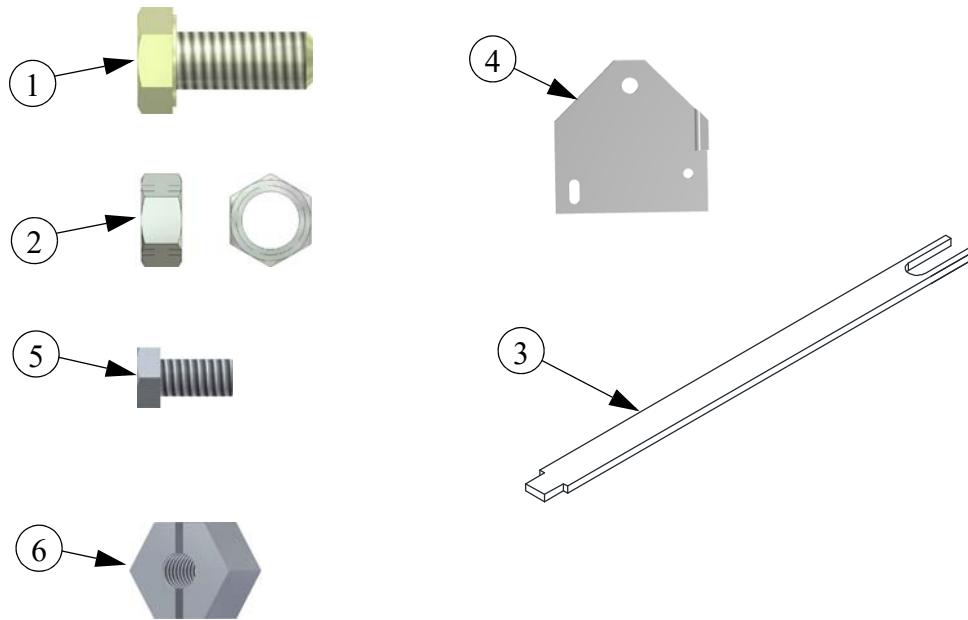

Item	Description	Part No.
1	5/16-18 x .75 Bolt	2046
2	5/16-18 Hex Nut	2145
3	Adjustment Leveler	3075
4	Anchor Plate	42807
5	10-24 x .38 Screw	1951
6	10-24 Slotted Nut	1840

Nipple Line Assembly and Components

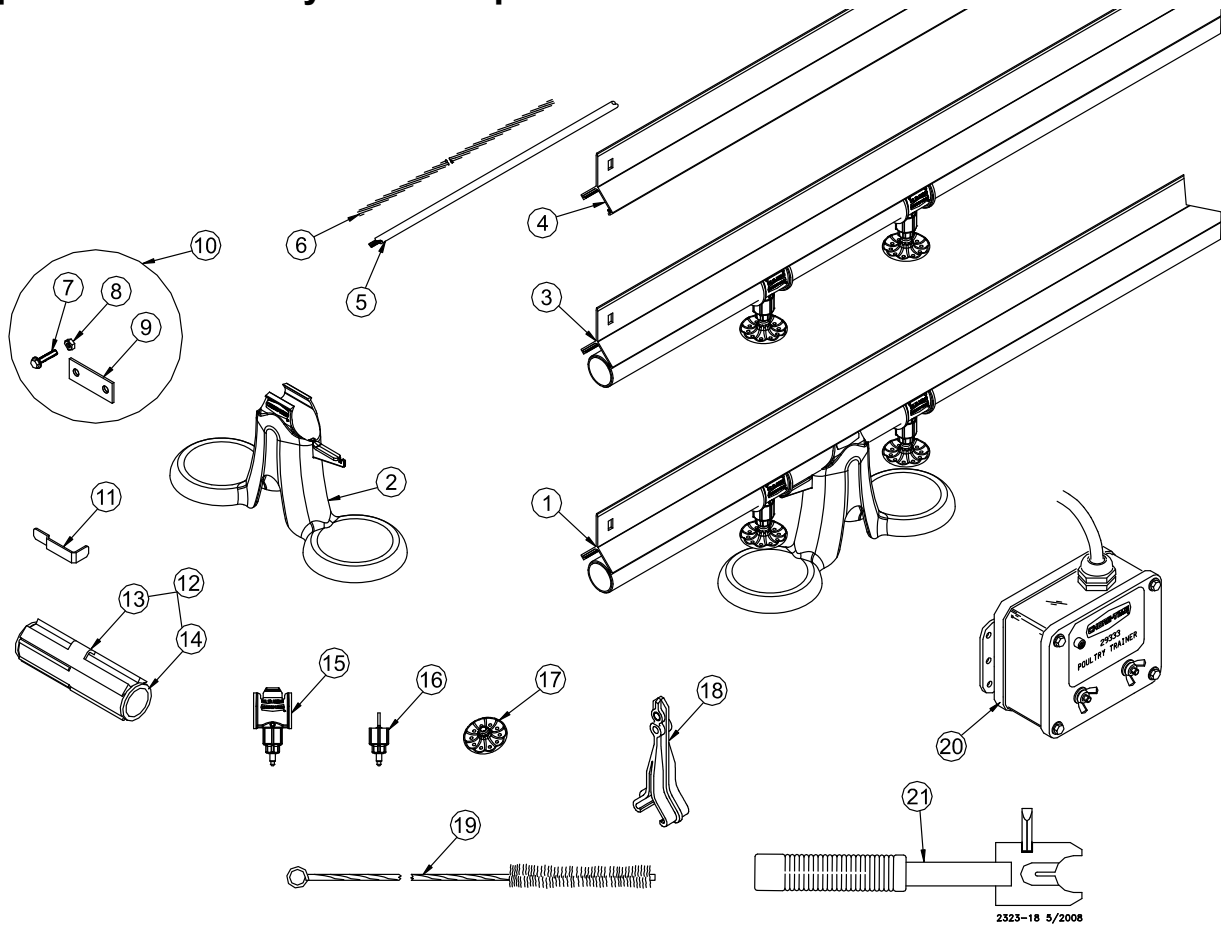

Item	Description	Part No.
1	ADVANTI-FLOW® Drinker Assembly with Cups	
	Strd. Flow Strd. Channel 40" Spacing w/Cups	51327-3
	Strd. Flow Strd. Channel 30" Spacing w/Cups	51327-4
	Strd. Flow Strd. Channel 24" Spacing w/Cups	51327-5
	Strd. Flow Strd. Channel 20" Spacing w/Cups	51327-6
	High Flow Strd. Channel 40" Spacing w/Cups	51328-3
	High Flow Strd. Channel 30" Spacing w/Cups	51328-4
	High Flow Strd. Channel 24" Spacing w/Cups	51328-5
	High Flow Strd. Channel 20" Spacing w/Cups	51328-6
2	ADVANTI-FLOW® Cup Package	51326
3	ADVANTI-FLOW® Drinker Assembly	
	Standard Flow Strd. Channel 40" Spacing	51271-2
	Standard Flow Strd. Channel 30" Spacing	51272-2
	Standard Flow Strd. Channel 24" Spacing	51273-2
	Standard Flow Strd. Channel 20" Spacing	51274-2
	High Flow Strd. Channel 40" Spacing	51271-1
	High Flow Strd. Channel 30" Spacing	51272-1
	High Flow Strd. Channel 24" Spacing	51273-1
High Flow Strd. Channel 20" Spacing	51274-1	
4	Standard Support Channel	35482-1
5	Training Wire (165 FT)	28994-165
	Training Wire (330 FT)	28994-330

Item	Description	Part No.
6	1/16" Training Cable (1 FT)	1922
	1/16" Training Cable (5000 FT)	1922-5000
7	#10-24 x 3/8" Hex Washer Head Screw	25124
8	#10-24 Kepnut	27725
9	Channel Bracket	46208
10	Channel Bracket Kit (40 Brackets per Kit)	46209-40
11	Support Channel Key	35480
12	Coupling Liner Assembly	35763
13	PVC Coupling Body	34318
14	Coupling Liner	34319
15	ADVANTI-FLOW® High Flow Saddle Assembly	51275-1
	ADVANTI-FLOW® Standard Flow Saddle Assembly	51275-2
16	ADVANTI-FLOW® High Flow Valve Assembly	51270-1
	ADVANTI-FLOW® Standard Flow Valve Assembly	51270-2
17	ADVANTI-FLOW® Disk	51266
18	Support Channel Hanger	33824-1
19	Pipe Brush	29465
20	Poultry Trainer	29333
21	Assembly Tool	41247

Slope Compensator Assembly

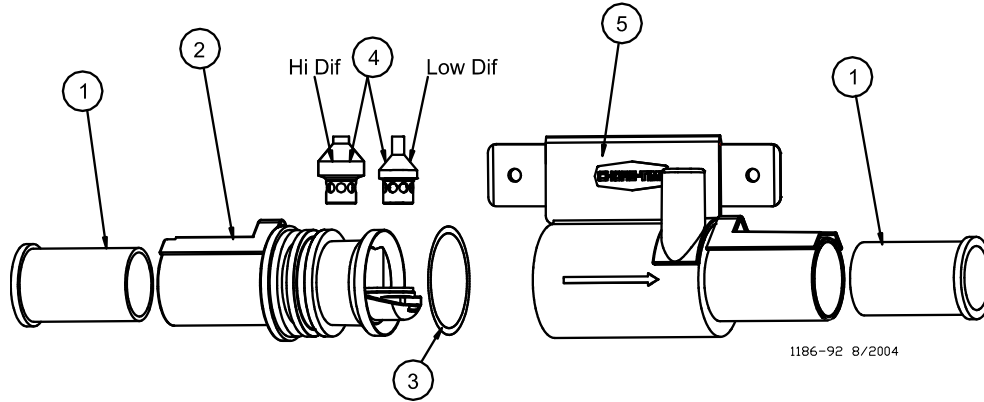

Item	Description	Low Dif	Hi Dif	Low Dif	Hi Dif	Low Dif	Hi Dif
		54036-1L	54036-1H	54036-2L	54036-2H	54036-4L	54036-4H
		Part No.	Part No.	Part No.	Part No.	Part No.	Part No.
1	Half Liner	36501	36501	36501	36501	36501	36501
2	Inlet Assembly	54037-L	54037-H	54037-L	54037-H	54037-L	54037-H
3	O-Ring	44015	44015	44015	44015	44015	44015
4	Plunger	46450	46451	46450	46451	46450	46451
5	Compensator Outlet	40902-1	40902-1	40902-1	40902-1	40902-1	40902-1
--	Stand Tube Assembly	54517-8	54517-8	54517-4	54517-4	54517-1	54517-1

Mid Line Shut-Off Kit: 29658

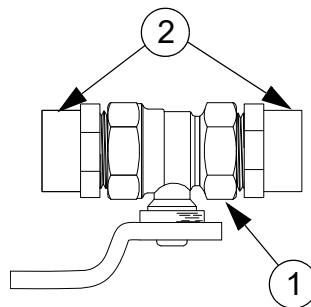

Item	Description	Part No
1	3/4" Quarter Turn Valve	29623
2	3/4" PVC Male Adapter	9229

Mid Line Stand Tube Assembly (52273-X)

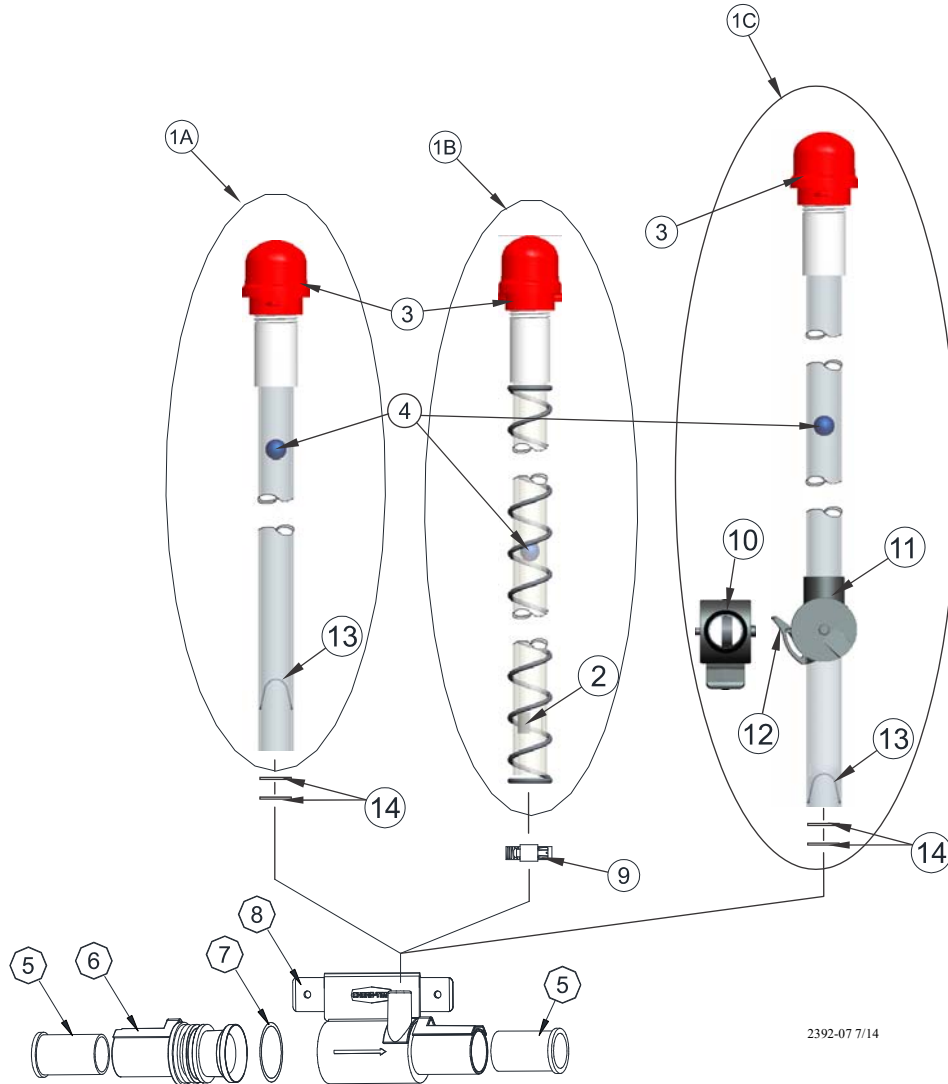

2392-07 7/14

Item	Description	52273-4 Part No.	52273-2 Part No.	52273-1 Part No.
1A	Rigid Stand Tube Assy	---	54517-4	
1B	Flexible Stand Tube Assy	54517-1	---	
1C	Folding Stand Tube			54517-8
2*	Flexible Ball Stop	54590-1	---	---
3*	Breather Cap Assembly	54606	54606	54606
4*	Blue Ball	37142	37142	37142
5	Half Liner	36501	36501	36501
6	Inlet Assembly	46464	46464	46464
7	O-Ring	44015	44015	44015
8	Compensator Outlet	40902-1	40902-1	40902-1
9*	Adjustable Clamp	49529	7187	7187
10*	O-Ring	---	---	52137
11*	Outer Stand Tube Body	---	---	54561
12*	Inner Stand Tube Body	---	---	54560
13*	Rigid Ball Stop	---	54817	54817
14*	O-Ring	---	48325	48325
--	Ground Wire	36500W	36500W	36500W
*Included in 54517-X Assembly				

Miscellaneous Kits and Components

Miscellaneous Hose Components

Description	Part No.
Female 3/4" Hose Coupling Kit	7812
3/4" NPT x 3/8" Hose Barb	37141
3/8" Nylon Hose Clamp	37144
3/4" Female Swivel Fitting	50401
Hose Clamp	7187
3/4" ID Rubber Hose	*47820-0

***47820-0 is available in lengths of 50', 100', 150' and 200'.**

The numbers following the dash represent the length of hose (47820-50 is 50' of hose).

Water Medicator

Description	Part No.
Chemilizer (1-100 Ratio)	41778-1

Water Meters

Important: Line must be flushed out before installing water meters. Bleed air out of the water line, running air through the water meter will damage it.

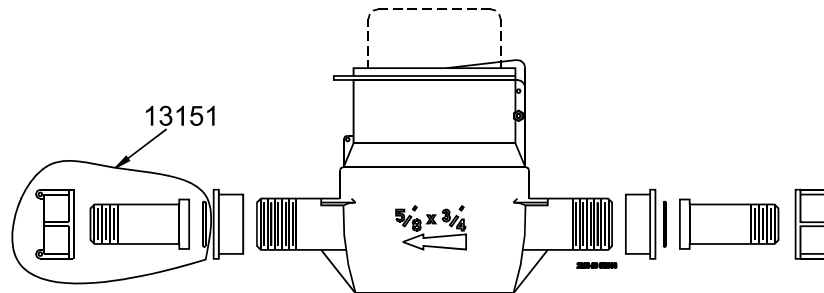

Description	Part No
3/4" Water Meter with Connectors (Liter)	54579-CM
3/4" Water Meter with Connectors (Gallon)	54579-G
3/4" Water Meter with Pulsar and Connectors (Liter)	E6900WM
3/4" Water Meter with Pulsar and Connectors (Gallon)	54579-GP

Mid Line Shut-Off Kit with Flush: 34939-X

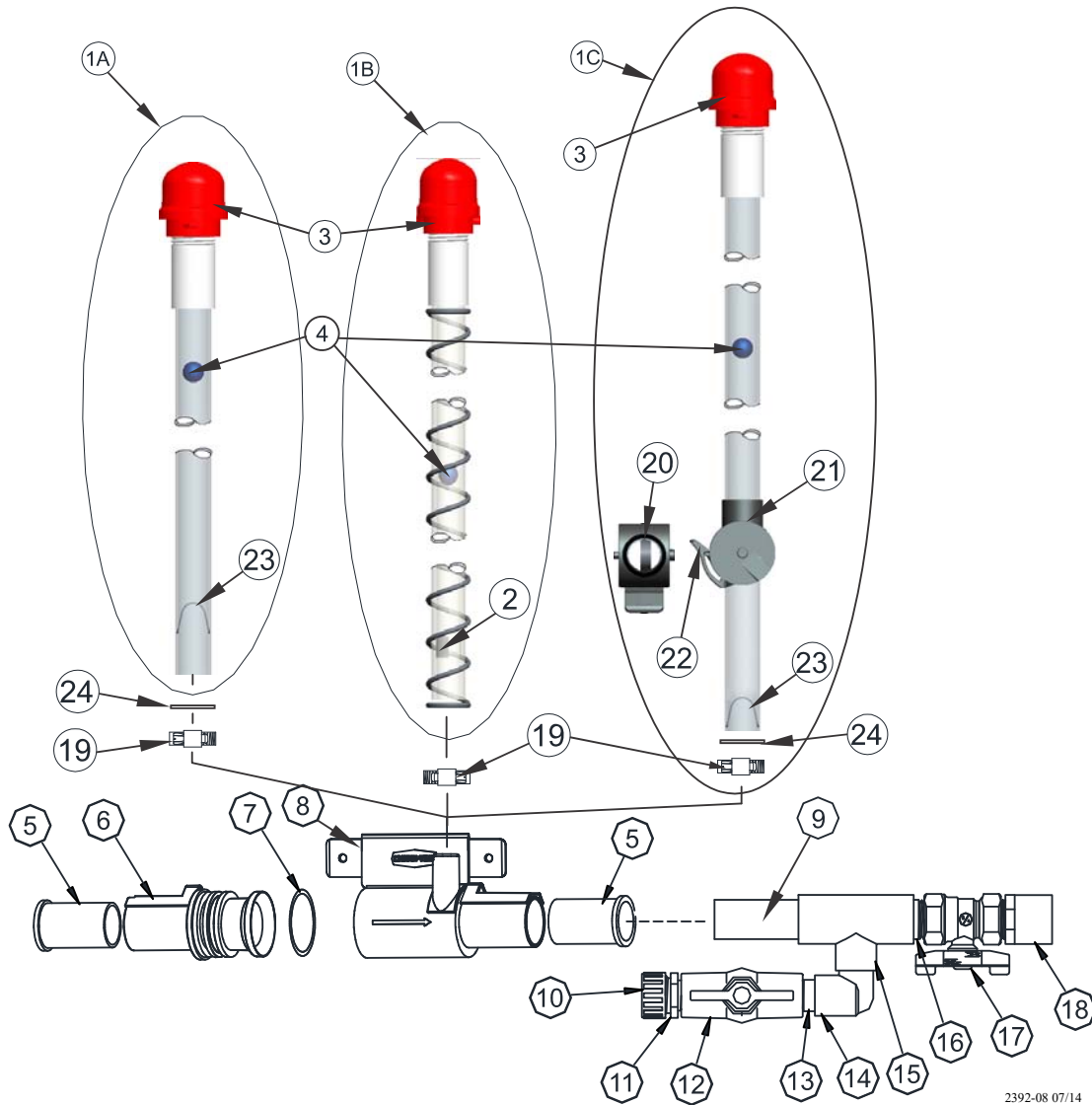

2392-08 07/14

Item	Description	34939-2 Part No	34939-4 Part No	34939-5 Part No
1A	Rigid Stand Tube Assy	---	54517-4	
1B	Flexible Stand Tube Assy	54517-1	---	
1C	Folding Stand Tube			54517-8
2*	Flexible Ball Stop	54590-1	---	---
3*	Breather Cap Assembly	54606	54606	54606
4*	Blue Ball	37142	37142	37142
5	Liner	36501	36501	36501
6	Inlet Assembly	46464	46464	46464
7	O-Ring	44015	44015	44015
8	Compensator Outlet	40902-1	40902-1	40902-1
9	3/4" x 3" PVC Pipe	9205-4	9205-4	9205-4
10*	3/4" Hose Cap	9811	9811	9811
11*	3/4" NH Nylon Adapter	29141	29141	29141
12*	1/2" Ball Valve	34961	34961	34961
13	1/2" Threaded PVC Pipe	34960-1	34960-1	34960-1

*Included in 54517-X Assembly

Item	Description	34939-2 Part No	34939-4 Part No	34939-5 Part No
14	1/2" Street S x S PVC Ell	33895	33895	33895
15	3/4 x 3/4 x 1/2" PVC Tee	7534	7534	7534
16	3/4" Threaded PVC Pipe	7531-5	7531-5	7531-5
17	3/4" Ball Valve	29623	29623	29623
18	3/4" PVC Male Adapter	9229	9229	9229
19	Adjustable Clamp	49529	7187	7187
20*	O-Ring	---	---	52137
21*	Outer Stand Tube Body	---	---	54561
22*	Inner Stand Tube Body	---	---	54560
23*	Rigid Ball Stop	---	54817	54817
24*	O-Ring		48325	48325
--	Ground Jumper Wire	36500W	36500W	36500W

*Included in 54517-X Assembly

Suspension System Components:

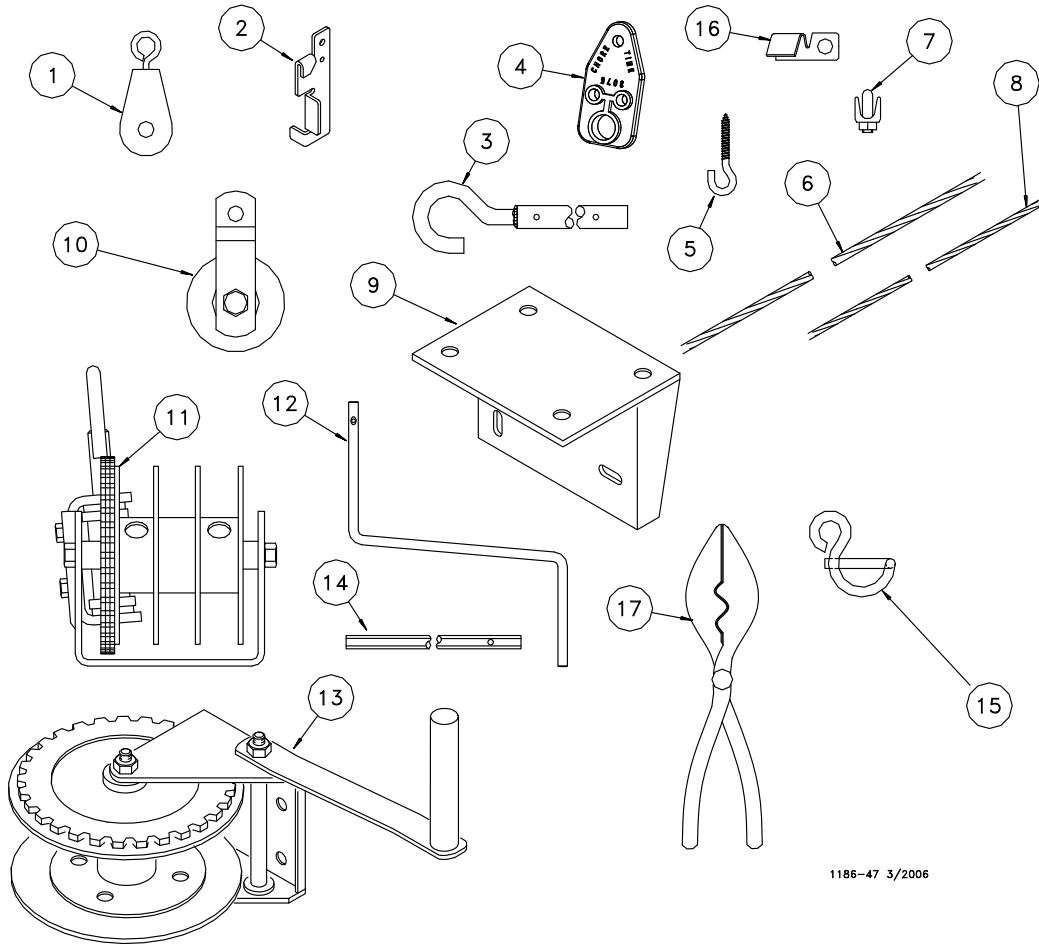

1186-47 3/2006

Item	Description	Part No.
1	Pulley with Swivel Hook	44577
2	Cable Lock	14337
3	Winch Drive Tube (4 ft.)	2884-1
	Winch Drive Tube (8 ft.)	2884-2
4	Rope Adjustment Leveler	3075
5	Screw Hook (Standard)	1214
	Screw Hook (Large)	2041
6	1/8" Cable	27975
7	1/8" Cable Clamp	14898
8	3/32" Drop Cable	4937
9*	Winch Bracket with Hardware	1193
10	Pulley	44596
11	Split Drum Winch	29428
12	Handle Shank	2885
13**	Hand Winch	1212
14	Drill Adapter Shaft	2886
15	Winch Handle Pin	3761
16***	Open 1/8" Cable Eyelet (Package of 100 pcs)	44598-100
17	Crimping Tool	44599
--	1/8" Rope	9247
<p>*Winch bracket to be used with hand winch only. **Hand winch is recommended for systems up to 150 ft [46 m] only.</p>		

CHORE-TIME ADVANTI-FLOW® Management Guideline

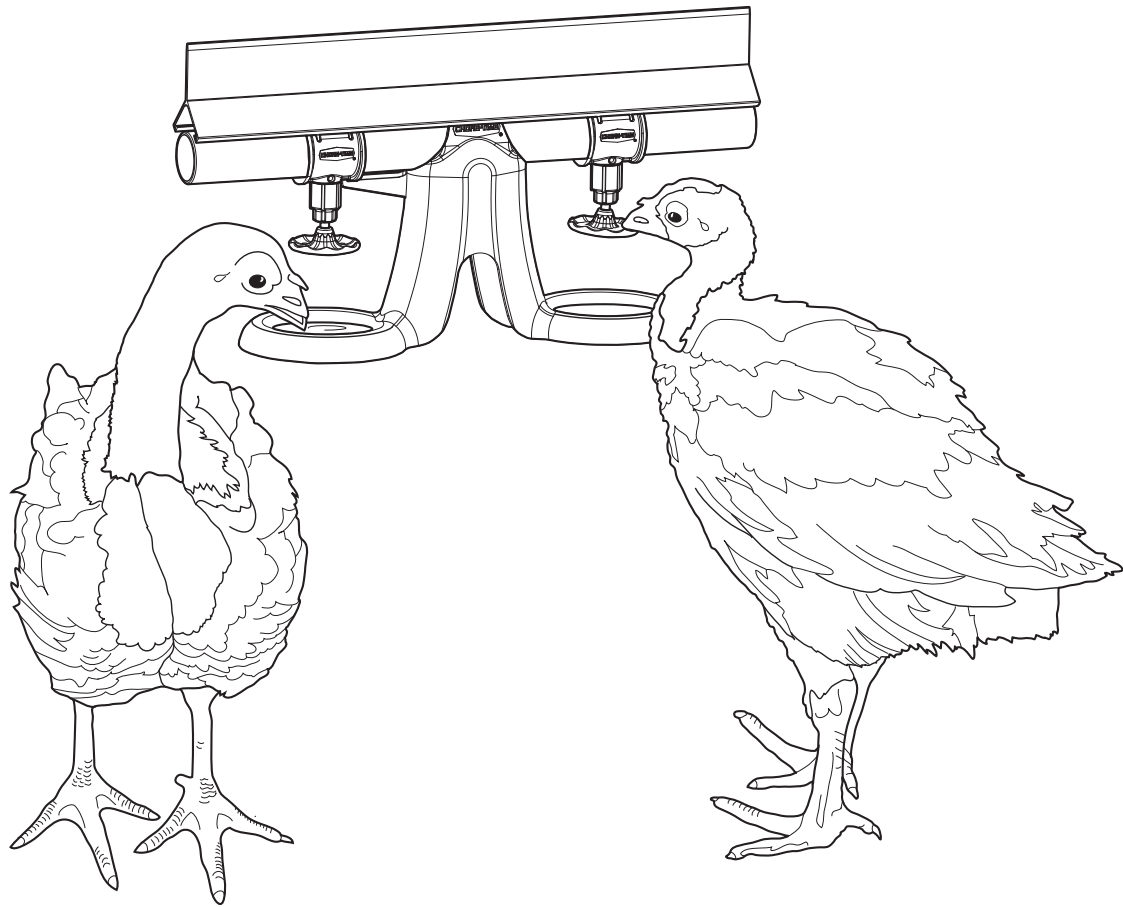

Weeks of Age	Water Column Height	
	Inches	cm
0 - 2	3 - 8	7.6 - 20.3
2 - 4	8 - 12	20.3 - 30.5
4 - 6 plus	12 - 20	30.5 - 50.8

- Water column height should be adjusted so water is present in the catch cups after one week, if the catch cups are empty the water column should be adjusted accordingly.
Be cautious adjusting the water column aggressively during the first week, this *could* increase mortality by making the nipples trigger harder.
- Drinker height should be managed so the disc is below the beak as shown in the picture above. Birds should not have to bend over, or reach excessively to trigger the disc.
- For maximum performance results and ideal house conditions, Chore-Time recommends starting birds with the ADVANTI-FLOW® Drinking system.

Note: The information provided in the tables is for reference only. It is up to the operator to use this guideline as a starting point to operate the system. Operator judgement of actual on site conditions may require modification to this management guideline.

Operational Guidelines

Topic	Recommendations
Initial Start-Up Procedure	<ol style="list-style-type: none"> 1. Thoroughly flush the water lines. 2. Set incoming water pressure to 25 psi [172 kPa] at the step regulator on the filter control panel. 3. Level the shavings under the water line to eliminate high/low spots. 4. Adjust the inlet regulators on the lines to the stand tube float corresponds to the recommended setting. Make sure there is water at the outlet sight tube and air is bled from the line. The indicator ball should be visible during operation. 5. Check the outlet assemblies and stand tubes to make sure water is passing throughout the system.
Bird Placement Procedure	Immediately before birds are housed, trigger all the nipples to ensure some water is present in the catch cups. Also, this ensures all nipple valves are working properly.
Operation During Bird Grow-Out	<ul style="list-style-type: none"> • Monitor drinker height based on the average bird size of the flock, See “CHORE-TIME ADVANTI-FLOW® Management Guideline” on page 37. Improper drinker height can lead to negative effects on bird performance. • Monitor water level in catch cups, See “CHORE-TIME ADVANTI-FLOW® Management Guideline” on page 37. • Monitor floor conditions under water lines.
Maintenance Between Batches	<ol style="list-style-type: none"> 1. Clean water lines with solution, See “Guide to Cleaning Water Lines” on page 40. 2. Check pressure drop across water filter - clean or replace if necessary. 3. Check regulator, shut-off valves, stand tube(s), and coupling assemblies for proper operation. 4. Adjust the cable levelers so the water lines are level. 5. Maintain house temperature above freezing or drain the lines thoroughly. Also drain regulator(s). 6. Clean stand tubes.
Precautions	<ul style="list-style-type: none"> • Do not over chlorinate. The maximum concentration is 2.5 ppm (parts per million) for extended periods and 5 ppm for flushing only. • If medication or other chemicals are added to the water, flush lines immediately after use, then chlorinate as specified. Allow 24 hours before adding additional chemicals (such as iodine, citric acid, etc.) or vitamins to the water,

Management Troubleshooting Guidelines

Problem	Cause	Solution
Catch Cups are Dry	Water Column is too low.	Increase water column height until desired water level is achieved.
	Nipples are obstructed or clogged due to build-up.	Clean with solution, See “Guide to Cleaning Water Lines” on page 40.
Floors are wet under drinker line	Drinker line is too high or low.	Adjust drinker height to the recommended guidelines,
	Water column is too high.	Decrease water column height and increase ventilation and/or heat.
Poor Water Consumption	Drinker line is too high or low	Adjust drinker height to recommended management guidelines.

Component Troubleshooting Guidelines

Problem	Cause	Solution
Nipples are leaking	Foreign material preventing proper valve operation.	Trigger nipple a few times to see if leak stops. If leak persists, disassemble valve, clean, and reassemble. Replace valve components and saddle if leak persists.
Leaking above cap assembly	Cap not properly tightened.	Tighten cap on saddle.
	Damaged saddle or cap.	Replace saddle or cap, nipple may not need to be replaced.
Leaking between saddle and PVC pipe	Damaged saddle.	Replace saddle nipple may not need to be replaced.
Leaking at coupler assembly	Damaged (flexible) coupler liner or damaged coupler.	Replace coupler liner and/or the PVC coupler.
Leaking or damaged regulator assembly	Damaged fittings or improperly installed fittings	Replace damaged or defective fitting(s). It may be necessary to order a union to reconnect the regulator fittings.
Stand tube not working properly, Attempts to adjust regulator have no effect on stand tube water column height.	<ul style="list-style-type: none"> • Depending on water quality and management techniques, the stand tube may require more frequent cleaning. • Stand tube is air-locked. • No activity on drinker valves. • Damaged cap or regulator. 	<ol style="list-style-type: none"> 1. Remove hose cap on top of stand tube. 2. Use a brush (available through Chore-Time) to thoroughly clean the stand tube. 3. Bend the flexible tube to allow the water and/or foreign material to exit the tube. 4. Clean and reassemble the components and check for proper water level. 5. Drinker valves must be triggered for water column height to change. 6. Repair or replace damaged cap or regulator.
	Drinker lines too close to feeder lines	See planning the system for recommended distance.
	System height is too low	Raise the system to the recommended management guidelines.
Regulator Leaking	A restriction or obstruction in the Nipple such as a kinked hose or closed valve at the end of the line.	Remove the restriction or obstruction

Guide to Cleaning Water Lines

Important: Chore-Time strongly recommends a regular cleaning program to eliminate water line contaminants.



WARNING: Mixing of incompatible chemicals can result in violent explosions or create combustible and toxic gases. Such chemicals pose a definite threat to personal health and safety.

Chore-Time does not recommend mixing chemicals without a specific formula provided by a reputable company.

Standard Cleaning Procedure

1. Mix the cleaning solution as indicated below.
2. Fill watering system with solution.
3. Allow solution to remain in lines 1 to 3 hours.
4. Flush system 1 minute per 100' [30.5 m] with clean water using high pressure.
5. Check filters, valve, and nipples for clogging from debris.
6. Adjust regulator pressure to normal operating pressure.

Regular Maintenance

The watering system should be cleaned one day every two weeks during the production cycle using a proportioner and **ONE of the following** stock solutions. Set the proportioner at 1 oz. (30 ml.) stock solution to 128 oz. (3785 ml.) of water.

- Vinegar stock solution = 64 fl. oz. (1893 ml.) white household vinegar + 64 fl. oz. (1893 ml.) water
- Citric Acid stock solution = 1 pack (205 gm) citric acid + 128 fl. oz. (3785 ml.) water.

End of Grow Out Cleaning

A chlorine solution should run through the watering system, using a proportioner, at 1 fl. oz. (30 ml.) stock solution to 128 fl. oz. (3785 ml.) water. The solution should be administered during one of the last 3 days of the grow out. This cleans the whole system including the nipple drinkers and sterilizes the entire system for the next grow out cycle.

1. Chlorine stock solution = 1 fl. oz. (30 ml.) 5-1/4% bleach (or similar source of 5-1/4% sodium hyperchlorite) + 128 fl. oz. (3785 ml.) water. This solution will yield about 2 PPM (parts per million) chlorine in the drinkers with average water. **Do not** exceed this level for an extended period of time (otherwise, damage to the system may occur). Also **do not** exceed 5 PPM for flushing watering system.

After Administering Vitamins, Medication or other Chemicals

Chore-Time recommends flushing and chlorinating lines immediately after administering vitamins, medication or other chemicals. Failure to flush and chlorinate can result in bacteria build-up which can reduce or prevent water flow. **Do not** exceed 5 PPM of Chlorine stock solution when flushing watering system.

Between Flocks

The watering system should thoroughly cleaned between flocks. A stronger cleaning solutions may be used since birds will not be drinking the water. It is important to thoroughly flush the system (after 1 to 3 hours) with clean water to prevent storing high concentrates of cleaning solution in the watering system until the next flock is placed.

Use **ONE of the following** stock solutions for cleaning the system between flocks. Set the proportioner at 1 oz. of stock solution to 128 oz. (3785 ml.) water.

- Vinegar stock solution = 128 fl. oz. (3785 ml.) white household vinegar.
- Citric acid stock solution = 4 pack (205 gm) citric acid + 128 fl. oz. (3785 ml.) water.

The watering system should also be thoroughly drained in cold weather.

Water Quality

Hardness

Hardness is the calcium and magnesium content of a water supply. These minerals are responsible for scaling that forms in hot water heaters, plumbing lines, humidifiers, dishwashers and all other water using appliances. Water containing hardness minerals are generally classified as:

Soft Water	0 - 1.0 GPG
Slightly Hard Water	1.1 - 3.5 GPG
Moderately Hard Water	3.6 - 7.0 GPG
Hard Water	7.1 - 10.5 GPG
Very Hard Water	10.6 GPG or greater

Iron

Iron, when present in amounts of 0.3 ppm or higher, can cause a yellow or rusty appearance in water. It can also cause staining of clothing and water fixtures. Iron can be found in two forms, clear (dissolved) or red (oxidized) water iron. Water refiners are capable of removing both types of iron. Higher amounts of iron may require further treatment.

Iron Bacteria

Iron bacteria can be found in water supplies containing clear water iron. The bacteria use the clear water iron as a source of energy, and at the same time, convert the iron to the red water state. These bacteria are not considered a health hazard, but can plug plumbing lines, fixtures and appliances. These bacteria also promote localized corrosion and impart a taste and/or color to water. Effective treatment requires shock chlorination of all plumbing lines prior to the installation of any equipment. This is followed by the installation of a chemical feed pump feeding chlorine to eliminate the bacteria, and a clarifying filter to remove the residue.

Acid Water

The acid content of a water supply is measured and reported in terms of pH units. Acid water causes staining of plumbing fixtures and corrosion of plumbing systems, which may necessitate expensive repairs. Water with a pH of less than 6.8 is considered acidic. A pH of 6.0 to 6.7 indicates a moderately acidic supply and should be treated with a neutralizing filter. A pH of 4.0 to 5.9 is considered extremely acidic and should be treated with a chemical feed pump feeding neutralizing compound.

Aggressive/Corrosive Water

Aggressiveness of water is measured by the stability index (A calculation from several factors in a water supply). A stability index of 7.5 or higher indicates the water may be corrosive tendencies. This type of corrosion may attack plumbing and fixtures causing rusty or blue/green stains. The use of a phosphate crystal cartridge will help to eliminate this problem.

Taste and Odor

Objectionable tastes and/or odors can be dissolved minerals, gases, organic contamination, or from chlorination. Treatment requires the installation of taste and odor tank filter for the whole house or a taste and odor cartridge filter for individual faucets.

Hydrogen Sulfide

Hydrogen sulfide is a dissolved gas common in some water supplies. It is detected by a rotten egg taste and/or odor of the water. Proper treatment requires the installation of a chemical feed pump system feeding household chlorine bleach, followed by a sediment filter to remove the precipitation.

Sand, Silt or Sediment

Sand, silt or sediments are found in many water supplies. It is usually detected by a cloudy or hazy appearance when the water is first drawn. Treatment requires the installation of a sediment filter to remove the particles.

**Made to work.
Built to last.**

Revisions to this Manual

Page No.	Description of Change	ECO Number
Various	Updated to new Regulator, Added Water Meter Info and various other changes	31800



Contact your nearby Chore-Time distributor or representative for additional parts and information.

Chore-Time Group
A division of CTB, Inc.
PO Box 2000
Milford, Indiana 46542-2000 USA
Phone (574) 658-4101 Fax (877) 730-8825
E-mail: www.choretimepoultry.com
Internet: poultry@choretime.com