

Cage Nipple Watering Installation & Operator's Manual

warranty • installation • operation •
parts list • maintenance

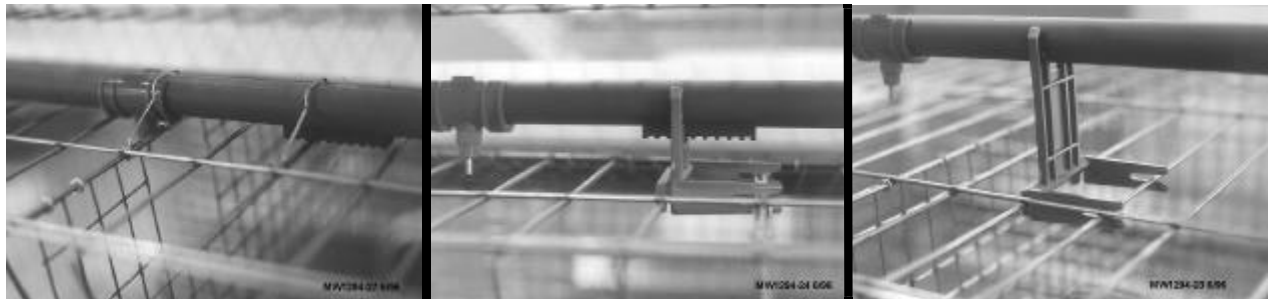

Warranty Information

Chore-Time Equipment warrants each new product manufactured by it to be free from defects in material or workmanship for one year from the date of initial installation by the original purchaser. If such a defect is found by Chore-Time to exist within the one year period, Chore-Time will, at its option, (a) repair or replace such product free of charge, F.O.B. the factory of manufacture, or (b) refund to the original purchaser the original purchase price, in lieu of such repair or replacement.

Additional extended warranties are herewith provided to the original purchaser as follows:

1. TURBO™ and RLX™ Fans, less motors, for three years from date of installation.
- *2. Poultry feeder pans that become unusable within five years from date of installation. Warranty prorated after three years usage.
3. MEAL-TIME® Hog Feeder pans that become unusable within five years of installation.
4. Rotating centerless augers, excluding applications involving High Moisture Corn (exceeding 18%), for ten years from date of installation. Note: MULTIFLO® and applications involving High Moisture Corn are subject to a one year warranty.
5. Chore-Time manufactured roll-formed steel auger tubes for ten years from date of installation.
- *6. Laying cages that become unusable within ten years. Warranty prorated after three years usage.
- *7. ULTRAFLO® Auger and ULTRAFLO® Feed Trough (except ULTRAFLO® Trough Liners) are warranted for a period of five (5) years from date of original purchase against repeated breakage of the auger or wear-through of the feed trough caused solely by the auger.

Conditions and limitations:

1. The product must be installed and operated in accordance with instructions published by Chore-Time or warranty will be void.
2. Warranty is void if all components of a system are not supplied by Chore-Time.
3. This product must be purchased from and installed by an authorized Chore-Time dealer or certified representative thereof, or the warranty will be void.
4. Malfunctions or failure resulting from misuse, abuse, negligence, alteration, accident, or lack of proper maintenance shall not be considered defects under this warranty.
5. This warranty applies only to systems for the care of poultry and livestock. Other applications in industry or commerce are not covered by this warranty.

Chore-Time shall not be liable for any consequential or special damage which any purchaser may suffer or claim to have suffered as a result of any defect in the product. "Consequential" or "special damages" as used herein include, but are not limited to, lost or damaged products or goods, costs of transportation, lost sales, lost orders, lost income, increased overhead, labor and incidental costs and operational inefficiencies.

THIS WARRANTY CONSTITUTES CHORE-TIME'S ENTIRE AND SOLE WARRANTY AND CHORE-TIME EXPRESSLY DISCLAIMS ANY AND ALL OTHER WARRANTIES, INCLUDING, BUT NOT LIMITED TO, EXPRESS AND IMPLIED WARRANTIES AS TO MERCHANTABILITY, FITNESS FOR PARTICULAR PURPOSE SOLD AND DESCRIPTION OR QUALITY OF THE PRODUCT FURNISHED HEREUNDER.

Any exceptions to this warranty must be authorized in writing by an officer of the company. Chore-Time reserves the right to change models and specifications at any time without notice or obligation to improve previous models.

*See separate Chore-Time Cage Wire Warranty as to these products.

CHORE-TIME EQUIPMENT, A Division of CTB, Inc.
P.O. Box 2000, Milford, Indiana 46542-2000 U.S.A.

Table of Contents

<u>Topic</u>	<u>Page</u>	<u>User*</u>
Warranty Information	2	C, D
Support Information	4	C, D
Tools Required	4	C, D
Miscellaneous Components	5	C, D, I
General Information.....	5	C, D, I
Planning the System Layout.....	6 - 7	C, D, I
Installing the Cage Nipple Watering System	8 - 18	I
Stand Locations	8 - 9	C, D, I
Wire Clip Locations	9	C, D, I
Stand Installations.....	9	C, D, I
Wire Clip Installations.....	9 - 10	C, D, I
Slop Compensators Installation (optional equipment).....	11	C, D, I
Mid-Line Air Remover Installation (optional equipment).....	12 - 13	C, D, I
Motor Location Installation	14	C, D, I
Pressure Regulator Assembly Procedure	14 - 15	C, D, I
Inlet End Assembly	15 - 16	C, D, I
Common Flush End Installation (preferred drain system).....	17	C, D, I
Hose Flush End Installation (alternative dray system)	18	C, D, I
Parts Listings	20 - 23	C, D, I
15 - 45 P.S.I. Regulator (Part No. 37147-5).....	20	C, D, I
4 - 14 P.S.I. Regulator.....	21	C, D, I
Cage Nipple Waterer Miscellaneous Components	22 - 23	C, D, I
Common Flush Drain Components.....	24	C, D, I
Hose Flush Drain Components	24	C, D, I
Operations Guidelines	25	C, D, I
Troubleshooting Guidelines.....	25	C, D, I
SURGE-PLUS™ Regulator Operation.....	26	C, D, I

*Legend: C = Customer (end user), D = Distributor (sales), I = Installer of equipment

Support Information

This manual is designed to provide comprehensive planning, installation, operation, and parts listing information. The Table of Contents provides a convenient overview of the information in this manual. The Table of Contents also specifies which pages contain information for the sales personnel, installer, and consumer (end user).

IMPORTANT: CE stands for *certified Europe*. It is a standard which equipment must meet or exceed in order to be sold in Europe. CE provides a benchmark for safety and manufacturing issues. CE is required only on equipment sold in Europe.

Chore-Time Equipment recognizes CE Mark and pursues compliance in all applicable products. Fill in the CE-Mark serial number in the blank space provided for future reference.

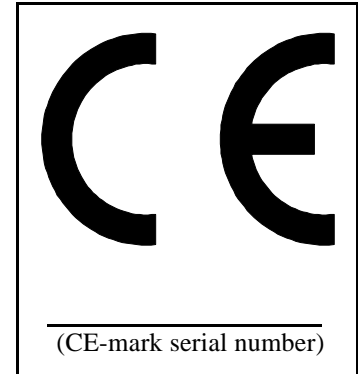

Please fill in the following information about your Nipple Watering System. Keep this manual in a clean, dry place for future reference.

Distributor's Name _____

Distributor's Address _____

Distributor's Phone _____ **Date of Purchase** _____

Installer's Name _____

Installer's Address _____

Installer's Phone _____ **Date of Installation** _____

System Specifications _____

Tools Required

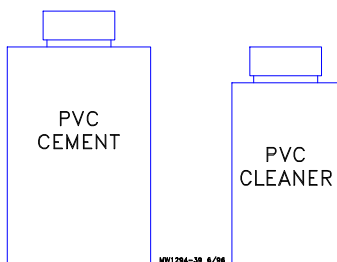

**PVC Cement
& Cleaner**

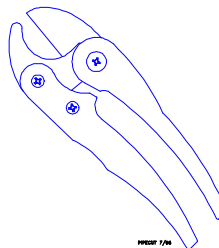

PVC Pipe Cutter

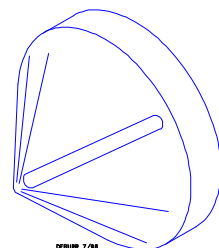

Deburring Tool

Miscellaneous Components

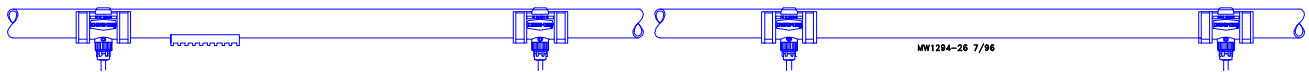

Nipple Waterer Pipe Assembly

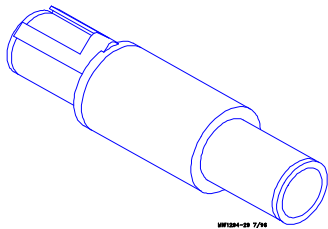

Slope Compensator

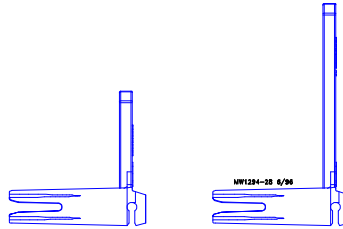

Short & Tall Stand

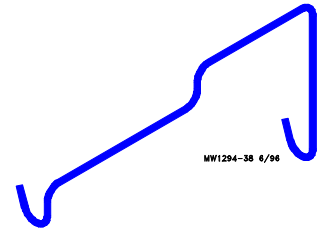

Wire Clip

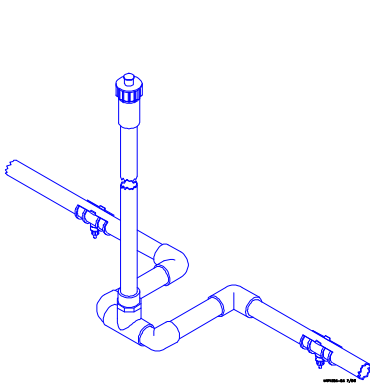

Mid-Line Air Remover

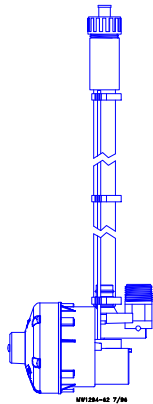

15 - 45 P.S.I. Regulator

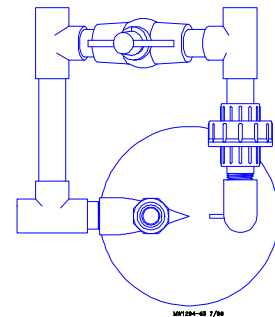

4 - 15 P.S.I. Regulator

General Information

It is extremely important to maintain good water quality. Good water quality maximizes performance of the equipment, minimizes maintenance and repair, and increases the life of the system. The water should be free of foreign particles.

Pump the well prior to hookup of the system to clear sand, mud, or debris. CHORE-TIME strongly recommends a water test by a reputable water treatment company in the area. Water treatment and/or extra filtration may be required, depending on the water test results.

The Nipple Watering System may be operated at incoming line pressures of 4 - 15 p.s.i. (27.6 - 110.1 kPa) or 15 - 45 p.s.i. (103.4 - 310.3 kPa).

CHORE-TIME recommends an incoming water supply pressure between 20 - 45 p.s.i. (137.8 - 310.2 kPa). If necessary, a Step Regulator should be installed to reduce the incoming pressure to 45 p.s.i. (310.3 kPa).

For every 28" (711 mm) drop in height, water pressure increases one pound. For every 28" (711 mm) rise in height, water pressure decreases one pound. Measure the operating pressure at the nipple height.

Incoming water supply should be at least a 1" (25 mm) diameter incoming line (preferably PVC) from a single well. If there are two or more supply wells, the supply line should be larger. Also depending on the distance from the well(s) to the Filter Control Panel, larger lines may be required.

Planning the System Layout

The single most important action the installer can do to insure proper operation and ease of installation is to carefully plan the installation process.

Due to the various options and nipple location choices available, it is very important that the installation process is carefully planned.

This manual includes the information necessary for installing the equipment, please follow it carefully.

Determine the Nipple Pipe Mounting Method

The Nipple Pipe may be mounted to the cage in several different ways. Determine which one best suits your individual needs (or which style you have received).

CHORE-TIME recommends locating the Waterer Line in directly in front of the Cage Leg on a Stand for most systems. If the lines are located behind the legs, excessive manure build up on the pipes may be expected.

Tall Stand

The Tall Stand may be used to hold the Nipple Waterer Line (bottom of pipe) approximately 3" (7.5 cm) above the cage.

This places the bottom of the Nipple approximately 1-3/4" (4.45 cm) above the top of the cage.

Figure 1. Tall Stand Installation

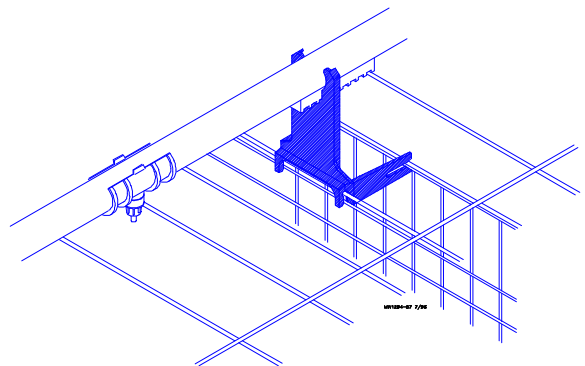

Short Stand

The Short Stand may be used to hold the Nipple Waterer Line (bottom of pipe) approximately 1-1/2" (3.8 cm) above the cage.

This places the bottom of the Nipple approximately 1/8" (3 mm) above the top of the cage.

Figure 2. Short Stand Installation

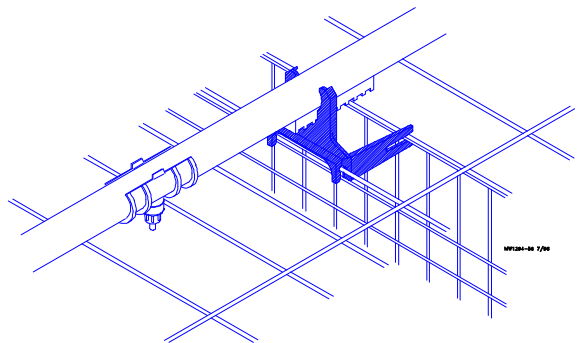

No Stand

The Nipple Waterer Line may be set directly on the top of the cage at the partition. The partition must be notched. See cage assembly manual.

Chore-Time does not recommend locating the Nipple in the center of the cage when no Stands are used.

Figure 3. No Stand Installation

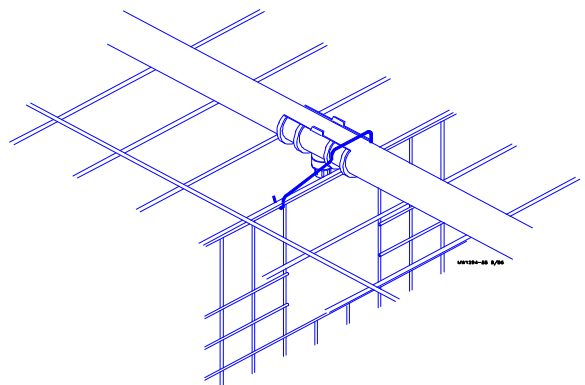

Planning the System Layout (continued)

Determine the Nipple Location

The Nipple Watering System may be installed so that the Nipples are located in the center of the cage, as shown in Figure 4, or at the Partition as shown in Figure 5.

Center of the Cage Location

If the Nipples are to be located in the center of the cage, make sure the Nipple is located in the center of the widest opening in the cage.

Figure 4 reflects a system supported by a Tall or Short Stand.

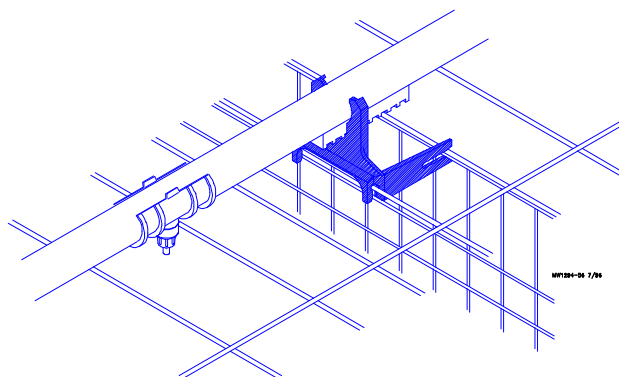

Figure 4. Nipple Located at Center of Cage

Partition Location

The Nipples may be located at the Cage Partition.

Figure 5 reflects a system with the water line setting on the cage top.

The Nipple should be located in the middle of the notch (front to back).

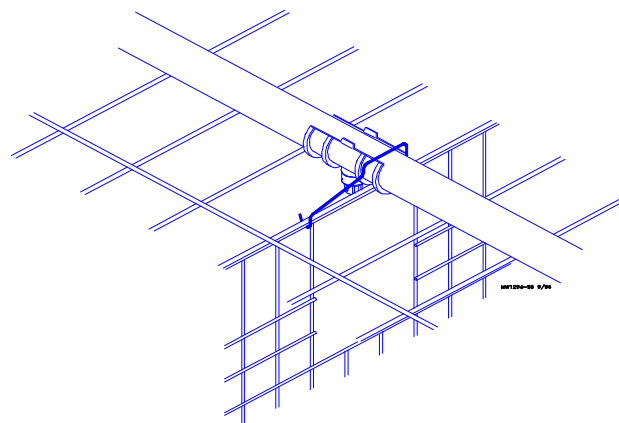

Figure 5. Nipple Located at Cage Partition

Installing the Cage Nipple Watering System

Lay out the Nipple Pipe Assemblies in the approximate locations they will be installed.

Determine the Nipple spacing on your system. Refer to the chart below to determine the distance between Stands or Wire Clips. Example: If your system will have Nipples on 15" (38.1 cm) spacings, the Stands or Wire Clips would be located every 30" (76.2 cm).

When laying the Nipple Pipe Assemblies on the cage, the Locator Block (on the Nipple Pipe Assembly) must be on the left.

- IMPORTANT -
Failure to position the Locator Block to the left will result in the Nipples not hanging in the cages straight. This will cause the Nipples to not seat properly.

Nipple Spacing (O.C.)	Stand Spacing (O.C.)	Wire Clip Spacing (O.C.)
12" (30.4 cm)	24" (60.9 cm)	24" (60.9 cm)
15" (38.1 cm)	30" (76.2 cm)	30" (76.2 cm)
16" (40.6 cm)	32" (81.2 cm)	32" (81.2 cm)
20" (50.8 cm)	40" (101.6 cm)	40" (101.6 cm)
24" (60.9 cm)	24" (60.9 cm)	24" (60.9 cm)
32" (81.2 cm)	32" (81.2 cm)	32" (81.2 cm)

- NOTE -
When using the Wire Clips, one additional Wire Clip for each Nipple Pipe Assembly is provided to be located at the Locator Block.

Stand Locations:

If the Nipples are to be located in the center of the cage, the Stands will be located at the Cage Partition. See Figure 6.

If the Nipples are to be located at the Cage Partition, the Stands will be located one wire to the left of the center of the cage. See Figure 7.

All Stand spacings will result in a Stand at the Locator Block.

- FEATURE -
The legs of the Stand are located in the Partition Wires. This prevents the Stands and Pipes from moving towards the front of the cage.



Figure 6. Stand Location with Nipple in Center of Cage

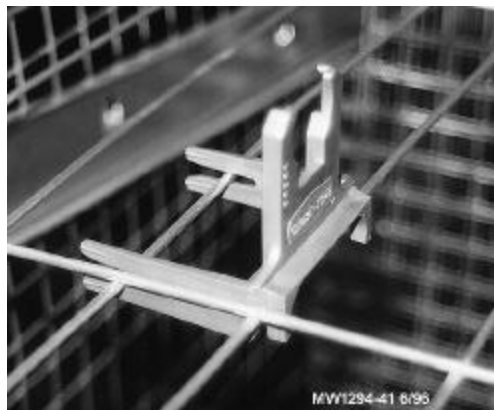

Figure 7. Stand Location with Nipple at the Partition

Wire Clip Locations:

A Wire Clip must be installed at the locations specified on page 8.

A Wire Clip must also be installed at each Locator Block. See Figure 8

- NOTE -

THE WIRE CLIP MUST BE LOCATED AROUND THE SADDLE BODY, AS SHOWN IN FIGURE 8.



Figure 8. Wire Clip Installation

Begin the installation at the inlet end of the water line.

Stand Installations:

Install the Stands on the first bank of cages, then position and snap a section of water pipe in place. Be sure the nipples are properly positioned in the center of the cages or at the partitions.

Position the Locator Block in the Stand. Notice which notch snaps into the Stand. Make sure all remaining Stands engage in the same notch throughout the system. This ensures consistent Nipple spacing.

Wire Clip Installations:

Position the first pipe on the first bank of cages. Be sure the nipples are properly positioned in the center of the cages or at the partitions. Also, make sure the Locator Block is straddling a cage wire. Install the Wire Clips as specified in Figure 8.

Install the remaining Stands (if used) on the top of the cages at the locations determined above and on page 8.

Refer to the Locator Block on the first pipe. Install the remaining pipes in the waterer line exactly the same. See Figure 9.

Example: If the Stand or cage wire is positioned in the fourth notch in the Locator Block, all the remaining pipes in the line **MUST** be installed with the Stand or cage wire in the fourth notch.

This will automatically maintain a proper distance between the pipes to allow for expansion and contraction.

- NOTE -
Make sure the Locator Blocks are on the left and the Nipples are straight down.

! Important !



Figure 9. Stand Installation

The pipes are connected using an Expansion Coupler, as shown in Figure 10. The Expansion Couplers include two O-Rings to seal the pipes and allow for expansion and contraction. Do not glue the Expansion Couplers to the pipes.

Center the Expansion Coupler over the pipe joint after both pipes have been properly set at the Locator Blocks.

Chore-Time Part Number for the individual components are shown on pages 20 - 21.

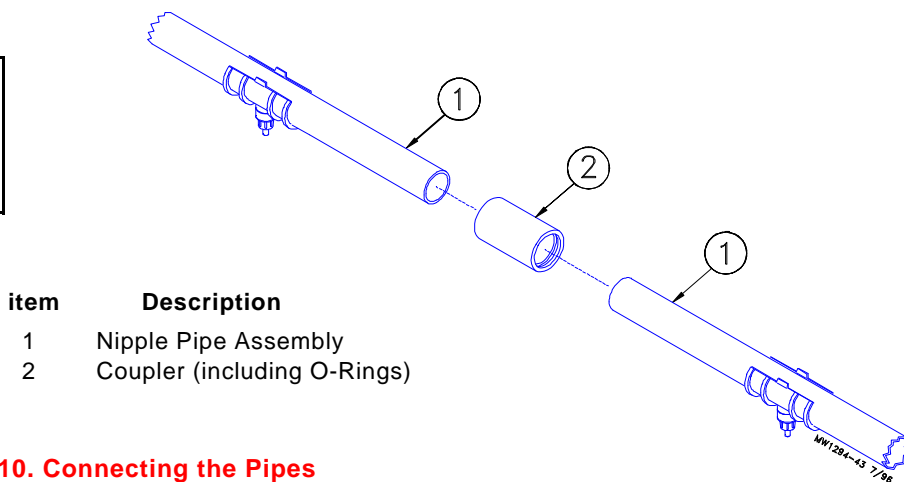

Figure 10. Connecting the Pipes

Slope Compensators Installation (optional equipment)

Installations that are sloped from one end of the house to the other, require the use of Slope Compensators. The Slope Compensators are optional equipment and must be ordered separately.

The Slope Compensators will be evenly spaced throughout the water line to reduce water pressure build up. They should be installed after the entire line has been installed.

Each Slope Compensator will reduce the water column by approximately 6" (15 cm).

Air Removers are optional but must be used when Slope Compensators are used.

1. Determine approximately where the Slope Compensator(s) should be located in the water line.

Water column will increase by 1" (2.5 cm) for every inch of slope in the floor. Therefore, if your floor is sloped 6" (15 cm) per 100' (30 m), a Slope Compensator should be located every 100' (30 m).

The Slope Compensator should be positioned **between the last two Nipples** on the appropriate Nipple Pipe Assembly. The Slope Compensator and Mid-Line Air Remover may be located next to each other in 20" & 24" spaced systems. All other spaced systems should have the Mid-Line Air Remover located as shown in Figure 11.

2. Cut approximately 4" (10.2 cm) out of the Nipple Pipe Assembly, as shown in Figure 11.

IMPORTANT

Note: Anytime the Nipple Waterer Line is cut, the ends must be deburred to prevent damage to the Expansion Couplers or Slope Compensators. Also, be sure to remove shavings from inside the pipe before continuing on with the installation.

The Slope Compensator includes Rubber Seals to prevent leaks to and allow for expansion and contraction.

3. For ease of installation, apply soapy water to the Rubber Seals prior to sliding on waterer pipe.

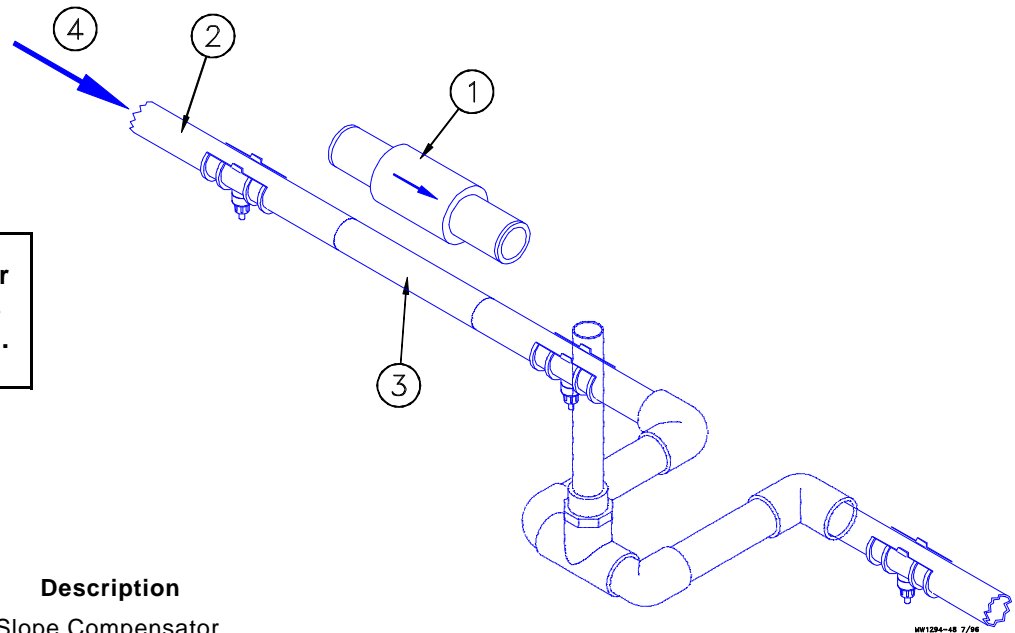

Chore-Time Part Number for the individual components are shown on pages 20 - 21.

Item	Description
1	Slope Compensator
2	Nipple Pipe Assembly
3	Cut out approximately 6" (15.2 cm) of Nipple Pipe Assembly for Slope Compensator.
4	Direction of Flow

Figure 11. Slope Compensator Installation

Mid-Line Air Remover Installation (optional equipment)

The Mid-Line Air Remover allows air to escape and serves as a visual gauge of how much water pressure (water column) is present down through the house.

Mid-Line Air Removers are required approximately every 150' (45.7 m) or just after each Slope Compensator (whichever results in more Air Removers).

The Mid-Line Air Remover is designed with a angle built in to slightly raise the Stand Tube/Breather Cap. This will provide improved air removal.

Each Mid-Line Air Remover requires the following components:

Base Components:

- (1) Cage Mid-Line Assembly (shipped assembled & glued)
- (2) 3/4" Elbows
- (2) 3/4" Pipe Nipples (not supplied, to be cut from 3/4" pipe)

Stand Tube Components:

- (1) Stand Tube (clear)
- (1) Indicator Ball
- (1) Breather Cap Assembly
- (1) Retaining Washer
- (1) Adapter (3/4" thread x 1/2" slip)
- (1) Slip Fitting (1/2" slip x 3/4" NH Thread)

Air Removers are optional but must be used when Slope Compensators are used.

1. Assemble the individual Stand Tube components (items 4 through 9, Figure 12), using PVC cement. It is suggested that these all be assembled on a work table and then distributed throughout the rows.

Note: Allow the glue to dry completely before placing the Indicator Ball in the Stand Tube.

2. Cut 3" (75 mm) off the right hand end of the proceeding pipe and cut 3" (75 mm) off the left hand end of the next pipe (this is where the Expansion Coupler would normally be located).

Note: Be sure the Stand Tube will not interfere with access to, and operation of, the cage door. The Slope Compensator and Mid Line Stand Tube Assembly may be located next to each other between the last two nipples of the appropriate Nipple Pipe Assembly (on 20" & 24" o.c. spaced nipple systems).

3. Loosely install the (2) elbows on the pipe ends, as shown in Figure 12. Do not glue the components together.
4. Thread one of the assembled Stand Tubes into a Cage Mid-Line Assembly (item #3, Figure 12).

The 3/4" Nipples must be measured and cut to the appropriate length to allow the Stand Tube to just clear the Egg Tray. The Stand Tube must be vertically straight. The (2) 3/4" Elbows must be 'flat' or 'square' with each other (to prevent air pockets from forming). See Figure 12.

5. Dry fit the complete assembly together, making sure;
 - a. it does not interfere with the cage door,
 - b. the Stand Tube is vertically straight,
 - c. the elbows are squarely aligned with each other,
 - d. the Stand Tube is against the Egg Tray, and
 - e. the Mid-Line Assembly is slightly higher than the Nipple Waterer Line.
6. Use PVC Cement to secure the Mid-Line Air Remover components together.
Use a Wire Tie (not supplied) to secure the Stand Tube Assembly to the Egg Tray.

Chore-Time recommends building the Mid-Line Assemblies and Stand Tubes on a work table.

- Cut enough 3/4" Nipples, as specified in step 4, for the remaining Mid-Line Air Removers.

Chore-Time Part Numbers for the individual components are shown on pages 20 - 21.

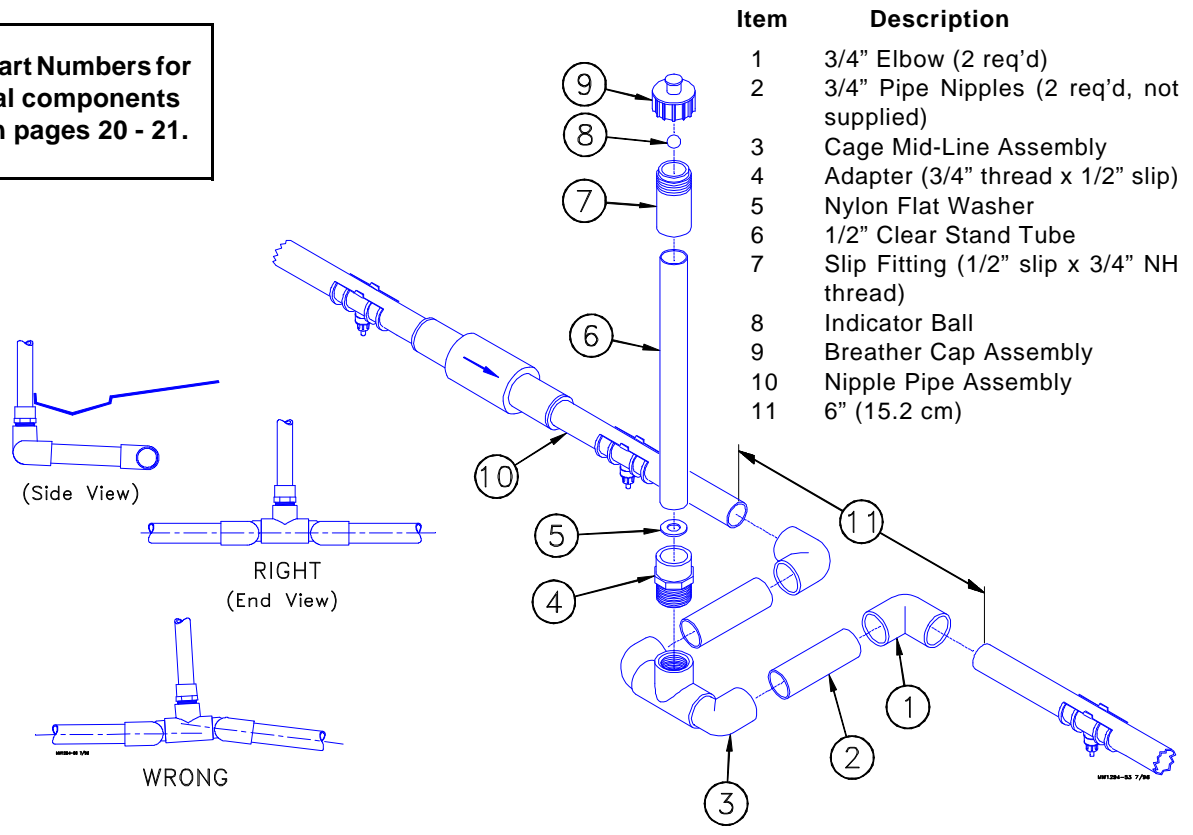

Figure 12. Mid-Line Air Remover Base Assembly

- Cut enough 3/4" Nipples, as specified in step 4, for the remaining Mid-Line Air Removers.
- If the ceiling height does not permit the use of the Stand Tube/air breathers, the low profile Mid-Line Air Remover is available. Do not use the low profile Mid-Line Air Remover at the front or back of the row, since they provide no visual indication of water pressure. If necessary, build a recessed area in the ceiling directly above the Mid-Line Air Remover to allow the Stand Tube Assembly to be used.
- Figure 13 shows a Mid-Line Stand Tube installed.

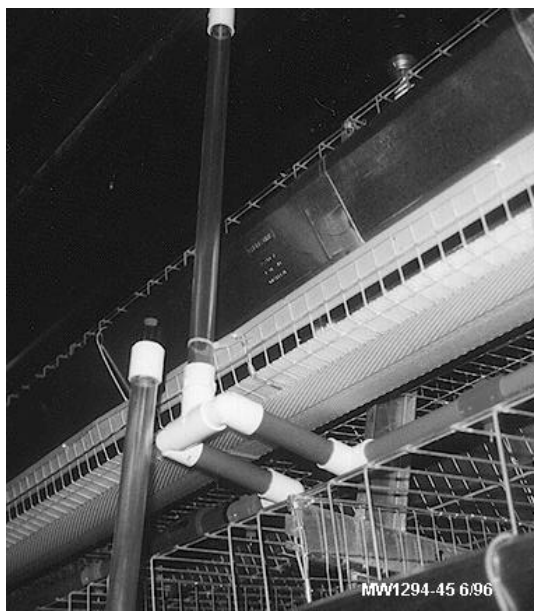

Figure 13. Stand Tube Assembly

Motor Location Installation

The Nipple Waterer Line must be cut at each motor location, then restarted after the motor.

Cut the Nipple Waterer Line near (or just inside) the motor opening. Be sure to properly deburr the end of the pipe to prevent damaging the O-Ring in the Slip Connector.

Install a Slip Connector on the end of the incoming Nipple Waterer Pipe, as shown in Figure 14.

Set the outgoing Nipple Waterer Line in it's appropriate location so that the Nipples and Locator Blocks are properly positioned.

Note: The Nipple and Locator Blocks should be positioned the same throughout the system.

Glue a Coupler on the incoming end of the outgoing Nipple Waterer Pipe.

Measure and cut an appropriate length 3/4" pipe to span the motor opening, as shown in Figure 14. Be sure to properly deburr the end of the pipe to prevent damaging the O-Ring in the Slip Connector.

Glue the 3/4" pipe in the Coupler, as shown in Figure 14, using PVC cement.

Insert the deburred end of the 3/4" pipe in the Slip Connector.

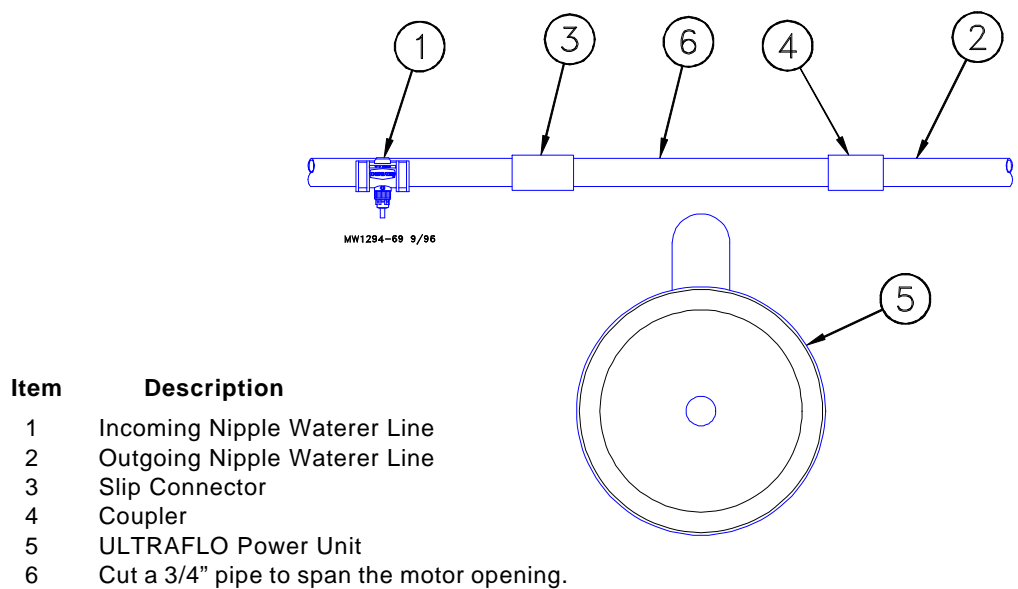

Figure 14. Motor Location Installation (front view)

Pressure Regulator Assembly Procedure

Assemble the Inlet Assembly components as shown in the appropriate diagram. Use PVC Cement (teflon paste on threaded connections) as required.

Figure 15 shows the High Pressure Inlet assembly procedure.

Figure 16 shows the Low Pressure Inlet assembly procedure. For ease of assembly, build Items 1, 2, 3, & 4 up as one assembly. Build the remaining components up as another assembly. Finally, glue the two assemblies together.

Chore-Time Part Numbers for the individual components are shown on pages 18 - 21.

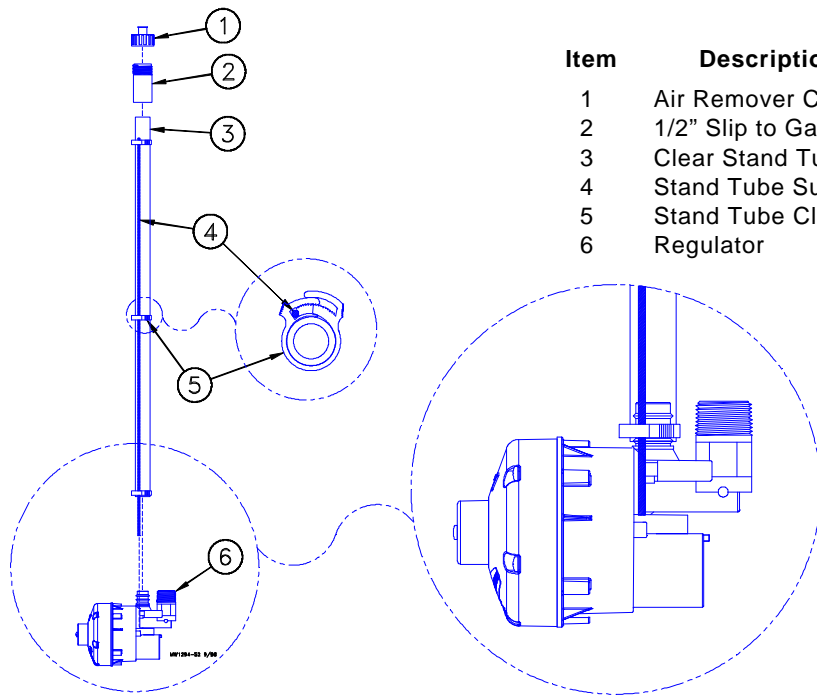

Item	Description
1	Air Remover Cap
2	1/2" Slip to Garden Hose Adapter
3	Clear Stand Tube - Flexible
4	Stand Tube Support Wire
5	Stand Tube Clamp
6	Regulator

Figure 15. 15 - 45 P.S.I Inlet Assembly

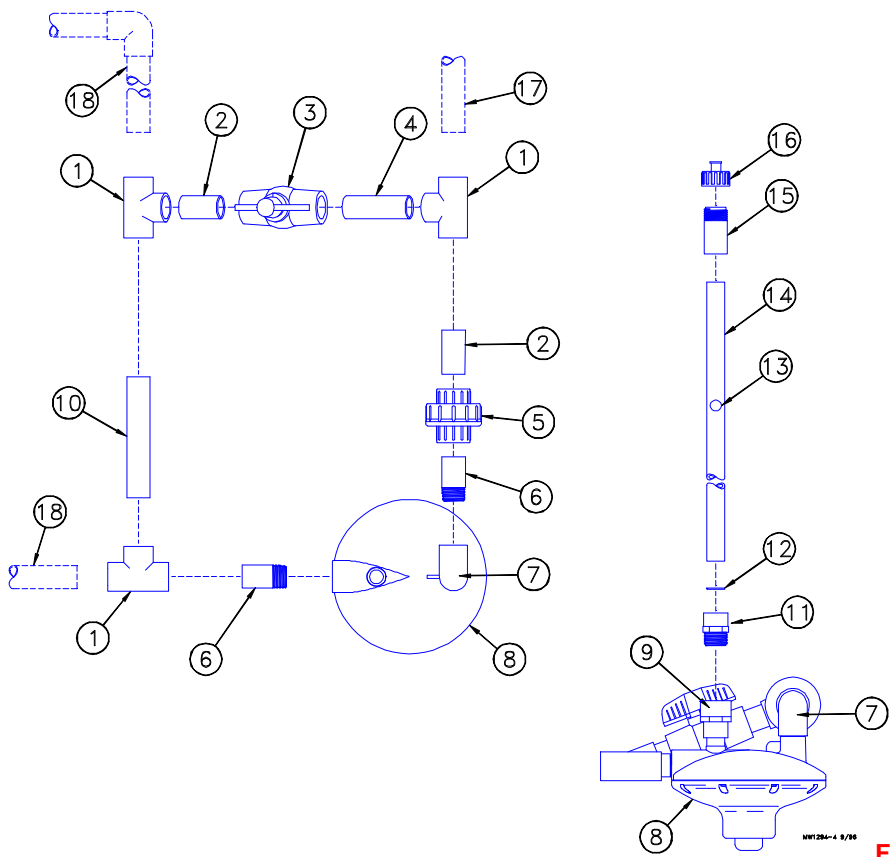

Item	Description
1	3/4" PVC Tee (sxsxs)
2*	3/4" x 2" PVC Pipe Nipple
3	3/4" PVC Ball Valve (sxs)
4*	3/4" x 3" PVC Pipe Nipple
5	3/4" PVC Union (sxs)
6	3/4" x 2" PVC Pipe Nipple
7	3/4" PVC Elbow (sxft)
8	Regulator
9	1/2 x 3/4 PVC Adaptor (sxft)
10*	3/4" x 5-1/2" PVC Pipe Nipple
11	Threaded Adapter
12	Washer
13	Indicator Ball
14	Clear Stand Tube
15	1/2" Slip to Garden Hose Adapter
16	Air Remover Cap
17	To Filter Panel
18	To Nipple Waterer Line

*These items must be cut in the field.

Figure 16. 7 - 15 P.S.I. Inlet Assembly

Inlet End Installation

Each Pressure Regulator is capable of supplying one tier (two lines) up to 600' (182.8 m). Systems over 600' (182.8 m) require two Inlet Assemblies per tier (one per line).

The Inlet Assemblies should be mounted on one side of the cage row in a location that can be easily reached for adjustment from the aisle and does not interfere with DBS, egg collectors, etc. Position the Inlet Assemblies in a position to prevent damage.

Note:
Make sure the Inlet Assembly is equal to or slightly higher than the nipple waterer line.

Dropping Board Scraper Systems: The Inlet Assemblies must be mounted in a location that does not interfere with the DBS equipment, Egg Collector, feeding equipment, vent (Turbo Baffle), etc. The installation location shown in Figure 17 is a suggestion, however, the Inlet Assemblies may be located in a variety of locations depending on the installation, operation, and location of other equipment. Additional Elbows and Tees may be required (order separately as required).

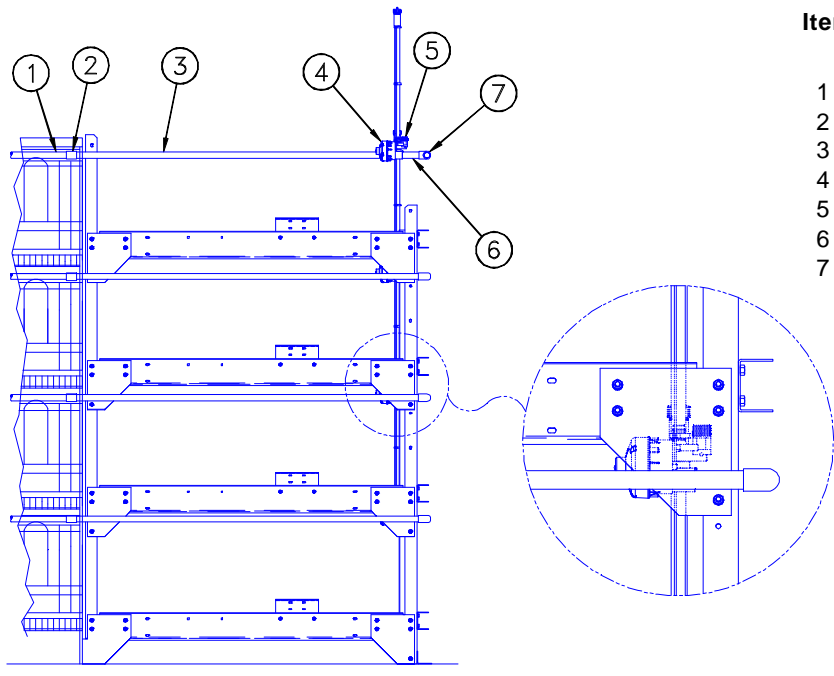

Item	Description
1	Nipple Pipe Assembly
2	3/4" Coupler
3	3/4" Pipe
4	Pressure Regulator
5	Incoming supply fitting
6	3/4" Nipple
7	3/4" Tee

Figure 17. Inlet End Installation on DBS Systems (side view)

Curtain Back Systems: The Inlet Assemblies should be installed near the end of the cage row. See Figure 18.

When one Regulator is used to supply both lines of a tier, use a 3/4" Nipple and 3/4" Tee to route water to each tier.

Chore-Time Part Numbers for the individual components are shown on pages 20 - 21.

Item	Description
1	Nipple Pipe Assembly
2	3/4" Coupler
3	3/4" Pipe
4	Pressure Regulator
5	Incoming supply fitting
6	3/4" Nipple
7	3/4" Tee

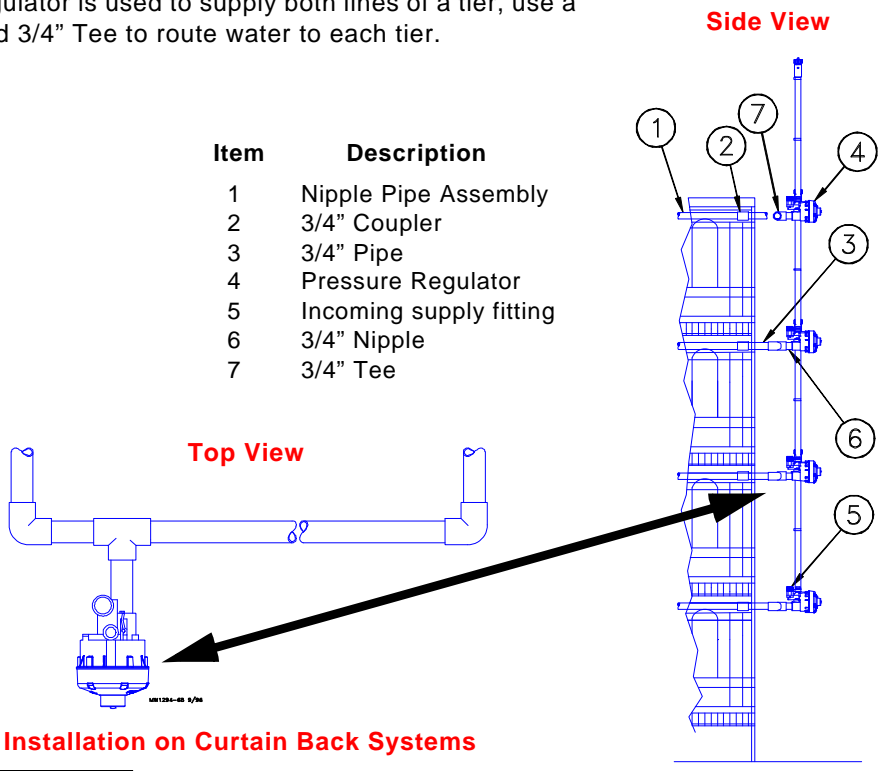

Figure 18. Inlet End Installation on Curtain Back Systems

Common Flush End Installation (preferred drain system)

The flush end components are shipped unassembled.

Figure 19 shows the flush end components assembled on a Curtain-Back Cage System. The quantity of each individual item required is listed for 3-Hi & 4-Hi systems.

Dropping Board System flush end components install similarly. However, the flush end components must be installed outside the End Framing to avoid interference with D.B.S. equipment. Use a section of 3/4" Pipe to extend the water lines to the End Framing.

Assemble the components as shown. Use PVC Cement to glue the fittings together.

Drill (4) 1/4" breather holes in the side of the 1-1/2" PVC Cap (near the top of the cap)

Chore-Time recommends connecting the 1-1/2" drain pipes to a properly sized cross drain line (1-1/2" minimum). Use an Elbow (not supplied) on one of the outside cage rows. This will serve as a common drain line to route the flush water to the pit, lagoon, etc.

Note: Make sure the Stand Tube Assemblies are slightly higher than the Nipple Waterer Line to aid in air removal.

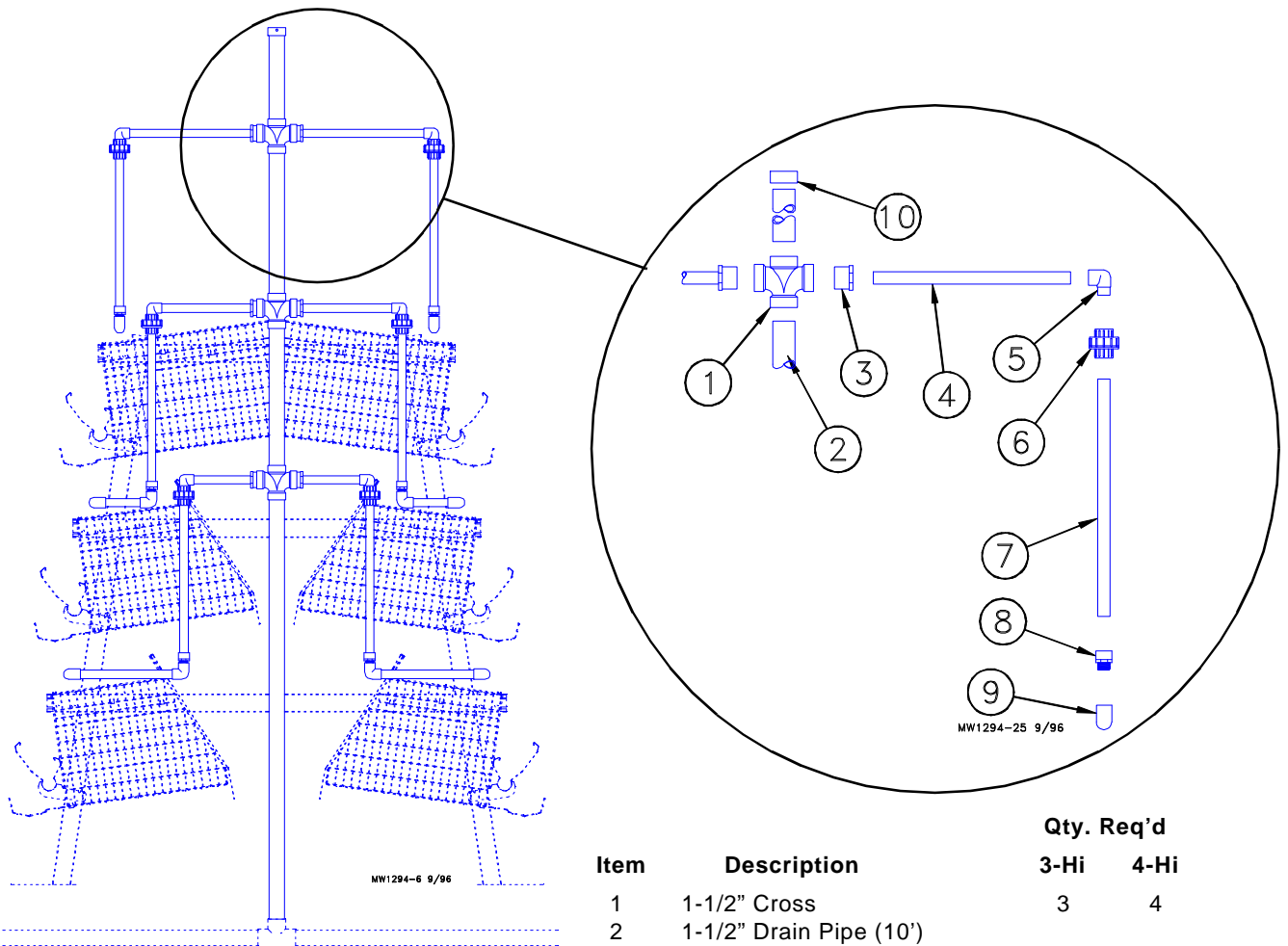

Chore-Time Part Number for the individual components are shown on page 22.

Item	Description	Qty. Req'd	
		3-Hi	4-Hi
1	1-1/2" Cross	3	4
2	1-1/2" Drain Pipe (10')		
3	1-1/2" x 3/4" Adapter (s x s)	6	8
4	3/4" PVC Pipe	6	8
5	3/4" Street Elbow	6	8
6	3/4" Union	6	8
7	Clear Sight Tube	6	8
8	3/4" Adapter (s x t)	6	8
9	3/4" Elbow (s x t)	6	8
10	1-1/2" PVC Cap	1	1

Figure 19. Flush End Installation

Hose Flush End Installation (alternative drain system)

The flush end components are shipped unassembled.

Figure 20 shows the flush end components assembled on a Curtain-Back Cage System.

Dropping Board System flush end components install similarly. However, the flush end components **may** be installed beyond the End Framing to avoid interference with D.B.S. equipment. Use a section of 3/4" Pipe to extend the water lines to the End Framing.

Assemble the components as shown. Use PVC Cement to glue the fittings together. Apply teflon paste to the threaded components (except item #8).

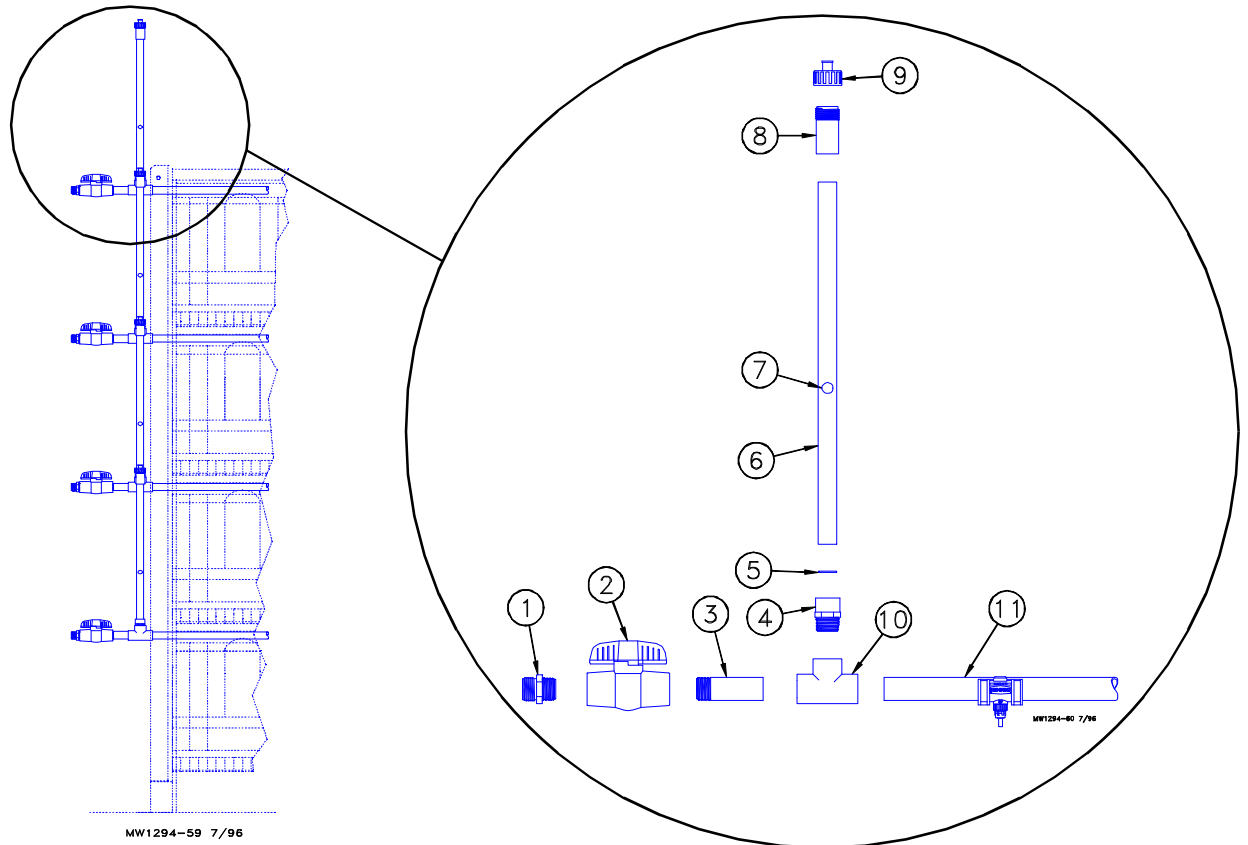

Figure 20. Stand Tube Assembly

Chore-Time Part Number for the individual components are shown on page 22.

Item	Description	Qty. Req'd	
		3-Hi	4-Hi
1	Adapter (thread x garden hose)	6	8
2	Shut-Off Valve (thread x thread)	6	8
3	3/4" x 3" Nipple (thread x slip)	6	8
4	Adapter (thread x slip)	6	8
5	Flat Washer	6	8
6	Clear Stand Tube	6	8
7	Indicator Ball	6	8
8	Adapter (thread x slip)	6	8
9	Breather Cap Assembly	6	8
10	3/4" Tee (slip x thread x slip)	6	8
11	Nipple Pipe Assembly	--	--

This page intentionally left blank.

15 - 45 P.S.I. Regulator Part No. 37147-5

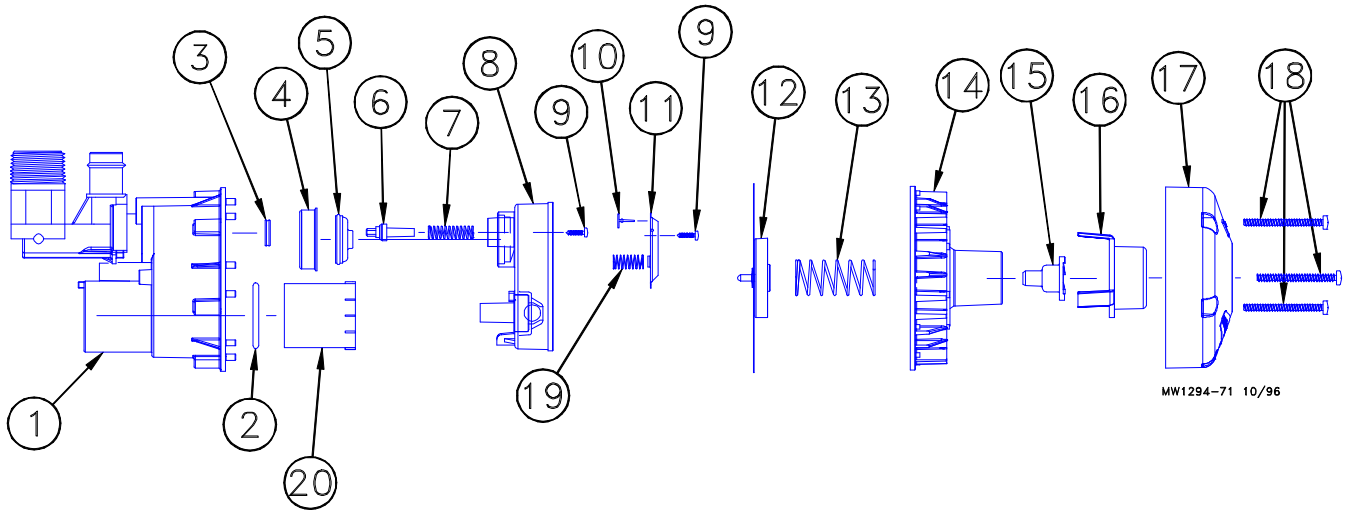

MW1294-71 10/96

Key	Description	Part No.
1	Inlet & Body Repair Part	----
2	O-Ring	----
2	Quad-Ring	----
4	Cup Valve	----
5	Valve Disc	----
6	Regulator Poppet	----
7	Compression Spring	----
8	Regulator Bulkhead Assembly	----
9	#2 Pan Head Screw	----
10	Seat	----
11	Regulator Lever	----
12	Regulator Plate	----
13	Compression Spring	----
14	Regulator Cap	----
15	Regulator Follower	----
16	Regulator Knob	----
17	Regulator Cover	----
18	#6 Pan Head Screw	----
19	Compression Spring	----
20	Regulator Sleeve	----

4 - 15 P.S.I. Regulator

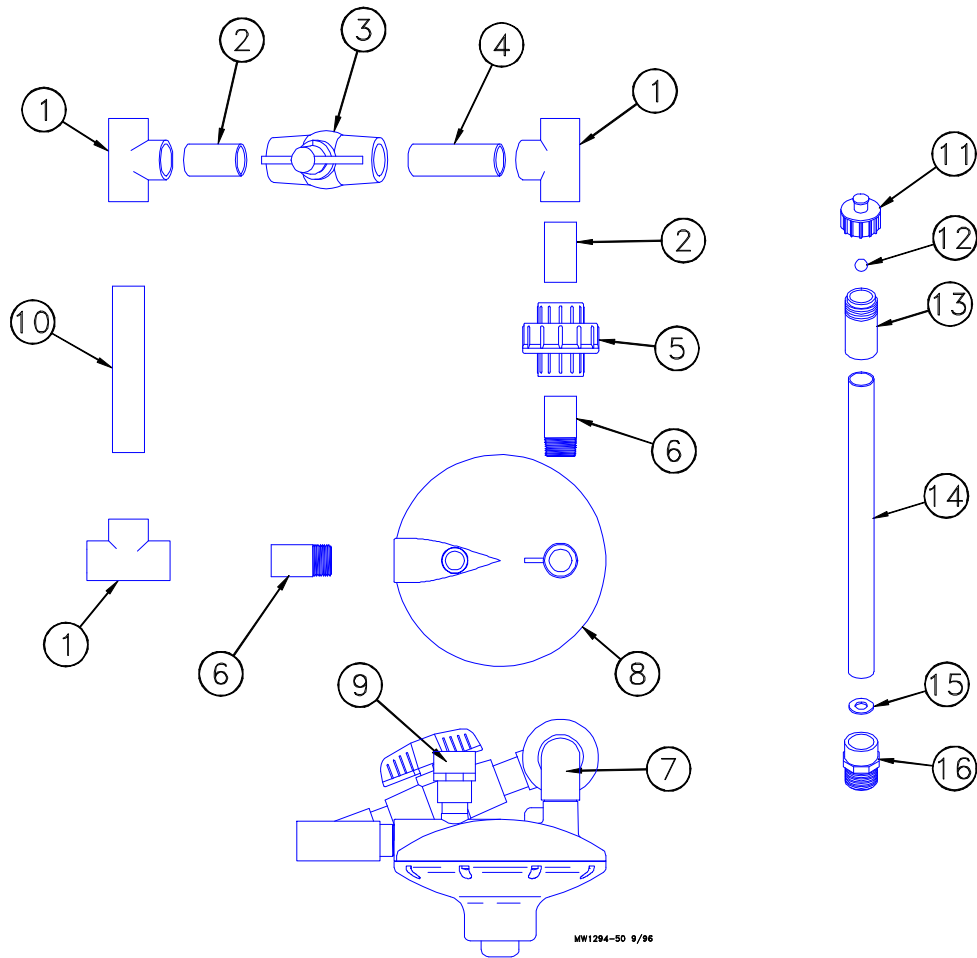

Key	Description	Part No.
1	3/4" PVC Tee (sxsxs)	7538
2*	3/4"x2" PVC Pipe Nipple	-----
3	3/4" PVC Ball Valve (sxs)	34728
4*	3/4"x3" PVC Pipe Nipple	-----
5	3/4" PVC Union (sxs)	8137
6	3/4"x2" PVC Pipe Nipple	7531-4
7	3/4" PVC Elbow (sxft)	7558
8	Low Pressure Regulator	35089
9	1/2x3/4 PVC Adaptor (sxft)	9062
10*	3/4"x5-1/2" PVC Pipe Nipple	-----
11	Breather Cap	38458
12	Indicator Ball	37142
13	1/2" Slip to Hose Adapter	25098
14	1/2" Clear PVC Pipe	38250-1
15	Restricting Washer	2955-54
16	1/2" to 3/4" PVC Adapter	9063

Note:

* Must be cut from pipe supplied by Chore-Time.

Cage Nipple Waterer Miscellaneous Components

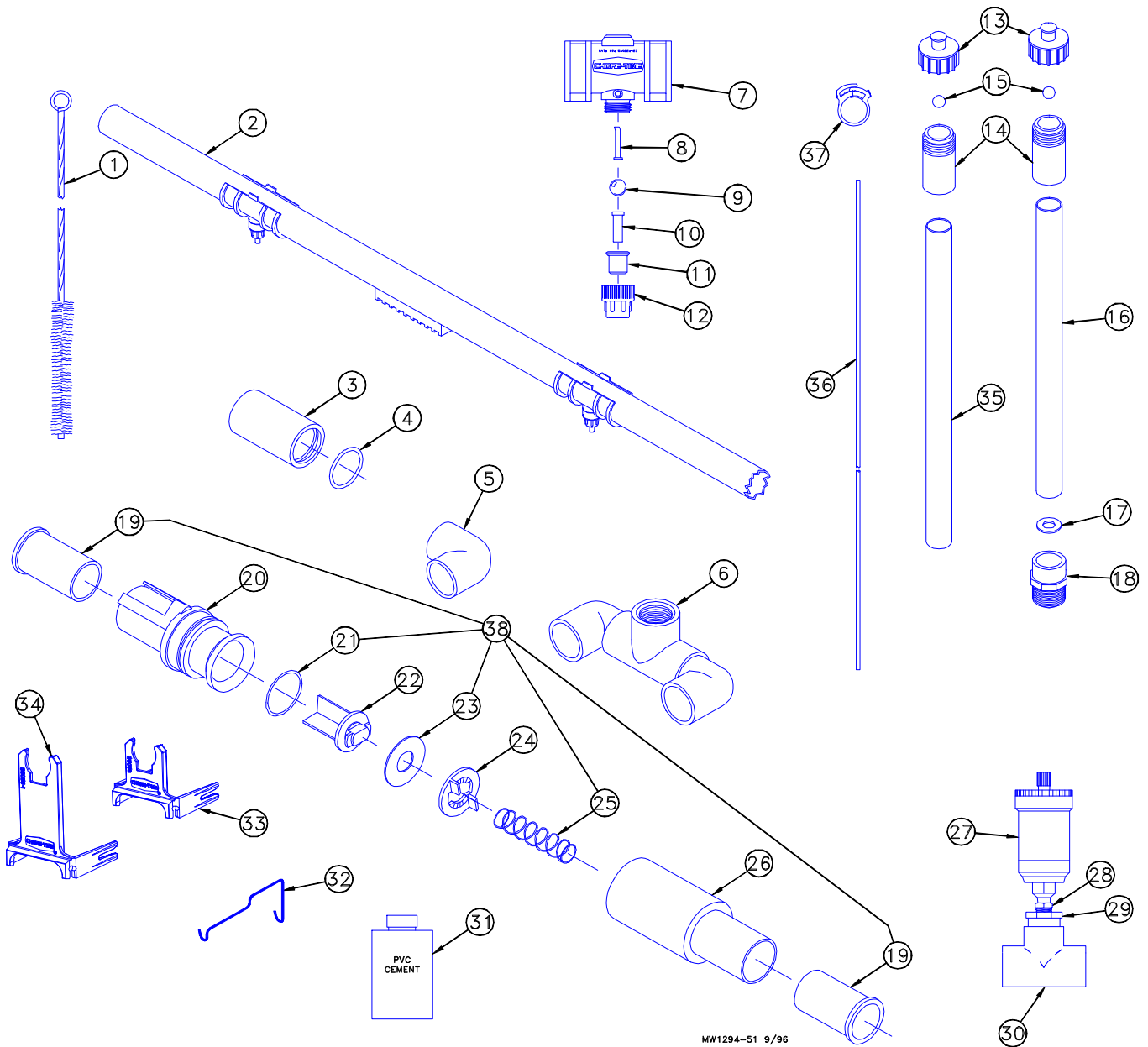

MW1294-51 9/96

Cage Nipple Waterer Miscellaneous Components (cont'd)

Key	Description	Part No.
1	Pipe Brush	29465
2	Cage Nipple Drinker Assembly	
	16" spacing (6 Nipples)	36108-16
	24" spacing (4 Nipples)	36108-24
3	Expansion Coupling Assembly	37311
4***	O-Ring	29118
5	3/4" S x S Ell	8141
6	Cage Midline Assembly	38249
7	Saddle Body	35457
8	Flow Control Pin	36725
9	Stainless Steel Ball	29117
10	Nipple Stem	29119
11	Nipple Insert	29470
12	Low Pressure Cap Assembly	29121
13	Breather Cap	38458
14	1/2" Slip to Garden Hose PVC Adapter	25098
15	Indicator Ball	37142
16	1/2" Clear PVC Pipe	38250-1
17	Restricting Washer	2955-54
18	1/2" Slip to 3/4" NPT PVC Adapter	9063
19**	Slope Compensator Liner	----
20**	Slope Compensator Inlet Housing	----
21**	O-Ring	----
22**	Slope Compensator Plunger	----
23**	Slope Compensator Seal	----
24**	Slope Compensator Washer Retainer	----
25**	Slope Compensator Spring	----
26**	Slope Compensator Outlet Housing	----
27§	Air Remover Valve	26151
28§	1/4 x 1/8 Reducer Bushing	27435
29§	1/2 x 1/4 Reducer Bushing	34405
30§	3/4 x 3/4 x 1/2 Tee (sxsxt)	34777
31	Clear PVC Solvent Cement	6303-4
32	CT Layer Nipple Pipe Clip	35952
33	Watering Pipe Bracket	35056
34	Watering Pipe Bracket	35056-1
35	Clear Stand Tube - Flexible	36840-1
36	Stand Tube Support Wire	38289
37	Hose Clamp Assembly	38288
38	Slope Compensator Repair Kit	39218

** These components may be ordered as an assembly under Chore-Time Part No. 36500-1 (non-vented, shown) or 36500-2 (vented, not shown).

***(2) O-Rings (Part Number 29118) are included with Item 3 (Part No. 37311).

§These components may be ordered as an assembly under Chore-Time Part No. 35780-3.

Common Flush Drain Components

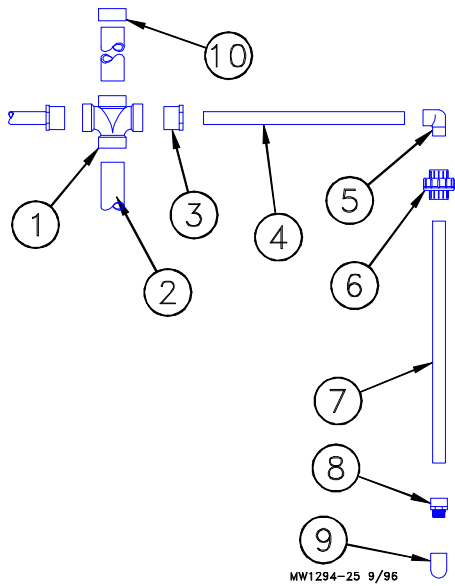

Key	Description	Part No.
1	1-1/2" PVC Cross (sxsxsxs)	38295
2	1-1/2" PVC Pipe	38296
3	1-1/2" to 3/4" PVC Reducer Bushing (sxs)	36808
4	3/4" PVC Pipe	8083-10
5	3/4" PVC 90 Degree St Elbow (sxs)	30138
6	3/4" PVC Union (sxs)	8137
7	3/4" Clear PVC Pipe	29153-2
8	3/4" PVC Male Adapter (sxt)	9229
9	3/4" PVC Ell (sxt)	7558
10	1-1/2" PVC Cap	38498

MW1294-25 9/96

Hose Flush Drain Components

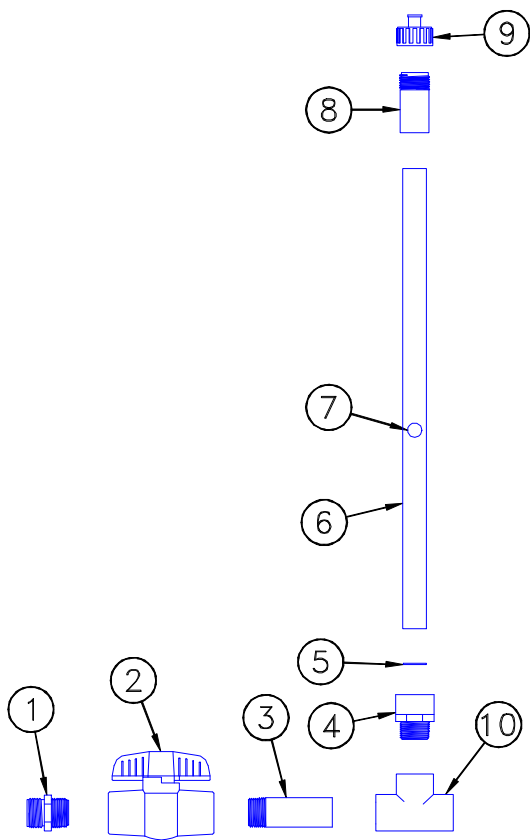

Key	Description	Part No.
1	Threaded Adapter (thread x garden hose)	7543
2	PVC Valve (thread x thread)	35781
3	3/4" x 3" Threaded Nipple	7531-4
4	Threaded Adapter (thread x slip)	9063
5	Flat Washer	2955-54
6	1/2" Clear PVC Pipe	38250-1
7	Indicator Ball	37142
8	1/2" x 3/4" Fitting	25098
9	Breather Cap	38458

MW1294-61 7/96

Operational Guidelines

Topic	Recommendations
Initial Start-Up Procedure	<ol style="list-style-type: none"> 1. Thoroughly flush the water lines. 2. Set incoming water pressure to 15 - 45 p.s.i. at the Filter Control Panel. 3. Adjust the Inlet Regulators on the lines so the red Stand Tube float corresponds to the drawing on page 30. Make sure there is water at the Outlet Sight Tube and air is bled from the line. Green Indicator Ball should be visible during operation. 4. Check Outlet Assemblies and Stand Tubes to make sure water is passing throughout the system.
Maintenance Between Batches	<p>Flush each line at full pressure for 5 minutes to remove deposits and sediments. Check pressure drop across water filter - clean or replace if necessary. Check Regulator, Shut-Off Valves, Stand Tube(s), and Coupling Liner Assemblies for proper operation. Maintain house temperature above freezing or drain the lines thoroughly. Drain Inlet(s). Make sure Air Remover Valves are in the open position.</p>
Precautions	<p>Do not over Chlorinate. The maximum concentration is 2.5 ppm (parts per million) for extended periods and 5 ppm for flushing only. If medication or other chemicals are added to the water, flush the lines immediately after use, then chlorinate, as specified. Allow at least 24 hours before adding additional chemicals (such as iodine, citric acid, etc.) or vitamins to the water.</p>

Troubleshooting Guidelines

Problem	Cause	Solution
Nipples are leaking.	Internal parts improperly assembled.	Disassemble and reassemble parts correctly.
	Foreign material preventing proper valve operation.	Disassemble valve, clean, and reassemble. Replace Valve components and Saddle if leaks persist.
Leaking above Cap Assembly	Cap not properly tightened.	Tighten Cap on Saddle.
	Damaged Saddle	Replace Saddle. Nipple may not need to be replaced.
Leaking between Saddle and PVC pipe.	Damaged Saddle.	Replace Saddle. Nipple may not need to be replaced.
Leaking at Coupler Liner Assembly.	Damaged (flexible) Coupler Liner or PVC Coupler.	Replace Coupler Liner and/or PVC Coupler.
Leaking or damaged Inlet Assembly.	Damaged component or improperly glued component.	Replace damaged or defective component(s). It may be necessary to order a union to reconnect the Inlet components.
Stand Tube not working properly.	Depending on water quality and management techniques, the Stand Tube may require more frequent cleaning.	<ol style="list-style-type: none"> 1. Remove Hose Cap on top of Stand Tube. 2. Use a brush (available through Chore-Time) to thoroughly clean the Stand Tube. 3. Bend the flexible tube to allow the water and/or foreign material to exit the tube. 4. Clean and Reassemble the components and check for proper water level.
End Line Assembly not functioning properly.	Air Remover Valve is closed.	Open Air Remover Valve.
	Depending on water quality and management techniques, the Air Remover Valve may require more frequent cleaning.	<ol style="list-style-type: none"> 1. Turn Air Remover Valve to closed position. 2. Remove the top of the Air Remover Valve, check internal parts for foreign material. 3. Reassemble the A.R.V.
	Depending on water quality and management techniques, the Air Remover Valve may require more frequent cleaning.	<ol style="list-style-type: none"> 1. Close water inlet valve. 2. Remove Outlet Air Remover at the female coupling. 3. Use a brush (available through Chore-Time) to thoroughly clean the Sight Tube. 4. Reassemble and install the components.

SURGE-PLUS™ Regulator Operation

The water column adjustment knob is on the back of the Regulator near the Chore-Time logo. To increase the water column turn the knob in the direction of the “I” or “+”. To decrease the water column turn the knob in the direction of the “D” or “-”.

The regulator has a unique “boost” option, that is, the Regulator will automatically increase the output water column as the flow rate increases. Do not operate the Regulator with the water column above the Stand Tube Spring top. Check this when water consumption is low.

For example, when the output water column is 12” (30.4 cm) the regulator will hold the water column steady until the flow rate reaches approximately .8 gallons (3 l.) per minute. At that time the Regulator will start to increase the water column. When the flow rate reaches one gallon (3.7 l) per minute the water column will increase approximately 4” (10 cm) from the original set point of 12” (30.4 cm). This will increase the flow rate the birds will be getting through the nipple.

For flushing, make sure the outlet valve on the end of the nipple line is in the open position and the line is not restricted in any way. To engage the flush mode push the small hexagon shaped pin on the front of the regulator in and to the side locking it open (it is normal for a small amount of water to leak through the open hole). The Regulator should go into high pressure flush immediately. To disengage the flush mode, push the pin in and center it in the small opening then allow it to “pop” out to its original position. Note: Once the pin is returned to the original position it will take 5 - 7 seconds for the Regulator to stop the flush mode. It may be necessary to create some back pressure on the regulator to make it come out of the flush mode (typical if the line length is short). This can be done by SLOWLY shutting off the outlet ball valve, or by raising the outlet flush hose in the air slightly.

This page intentionally left blank.

**THANK-YOU for purchasing a
Chore-Time Cage Nipple Watering System.**

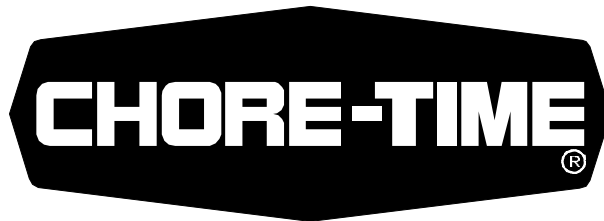

Made to work.
Built to last.™

Contact your nearby Chore-Time distributor or representative for additional parts and information.

Chore-Time Equipment, A Division of CTB, Inc.
P.O. Box 2000, Milford, Indiana 46542-2000 U.S.A.
Phone: 219-658-4101 • E-Mail: ctb@ctbinc.com

Printed in the U.S.A.