

CHORE-TIME[®]

Sprinkler System

Installation and Operators Instruction Manual

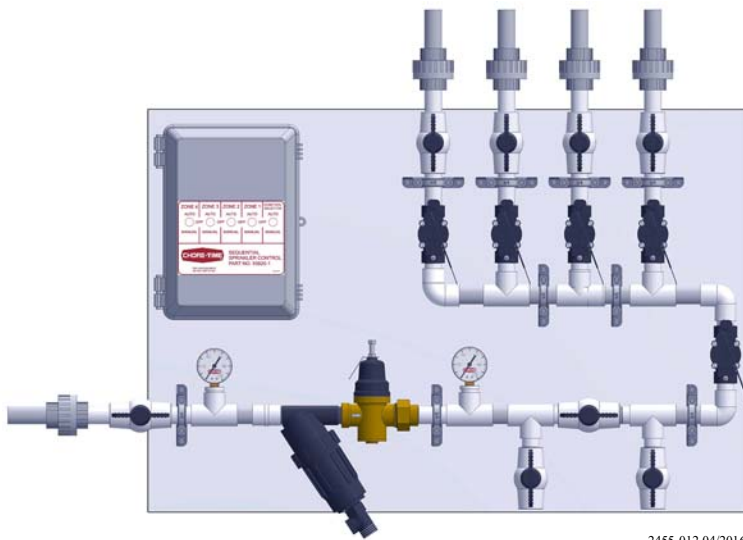

2455-012 04/2016



2455-016b 04/2016

Contact your nearby Chore-Time distributor or representative for additional parts and information.

Chore-Time Group
A division of CTB, Inc.
PO Box 2000
Milford, Indiana 46542-2000 USA
Phone (574) 658-4101 Fax (877) 730-8825
E-mail: www.choretimepoultry.com
Internet: poultry@choretime.com

Contents

Topic	Page
Safety and General Information	3
Follow Safety Instructions	3
DANGER: Electrical Hazard	3
General Information	3
Specifications	4
Water Supply Recommendations	4
Example Calculations	4
Features	4
Planning	5
Control Panel Location	5
Sprinkler Layout	6
.....	7
Plumbing Layout	8
Simultaneous (All at one time) Sprinkling	8
Sequential (Zone by Zone) Sprinkling	9
Installation	10
Control Panel Plumbing	10
Sequential (Zone by Zone) Control Panel (55630) with Doser Hook-up	10
Simultaneous Control Panel (55541-X)	10
Sprinkler Assembly/Plumbing	11
Flushing System	11
Installing Sprinkler Valves	12
Control Mounting	12
Wiring	13
Operation	14
Adjusting Water Pressure	14
Flushing	14
Functionality using Chore-Tronics® 2 and Chore-Tronics® 3	14
Overview and Requirements	14
Setup and Operation	14
Maintenance	16
Flushing System	16
Parts Listing	17
55630-X Sequential (with Doser Hookup) Sprinkler Control Panel	17
55541-X Simultaneous Sprinkler Control Panel	18
55644-XX Sprinkler Drop Line Kit (Qty 10 Sprinklers)	19
55620-1 Sprinkler Control (2-4 Zone Sequential)	20
.....	21
55620-2 Sprinkler Control (2-4 Zone Simultaneous)	22
.....	23

Safety and General Information

Caution, Warning and Danger Decals have been placed on the equipment to warn of potentially dangerous situations. Care should be taken to keep this information intact and easy to read at all times. Replace missing or damaged safety decals immediately.

Follow Safety Instructions

Carefully read all safety messages in this manual and on your equipment safety signs. Follow recommended precautions and safe operating practices.

Keep safety signs in good condition. Replace missing or damaged safety signs.

DANGER: Electrical Hazard

Disconnect electrical power before inspecting or servicing equipment unless maintenance instructions specifically state otherwise.

Ground all electrical equipment for safety.

All electrical wiring must be done by a qualified electrician in accordance with local and national electric codes.

Ground all non-current carrying metal parts to guard against electrical shock.

Electrical disconnects and over current protection are not supplied with the equipment.



General Information

The Chore-Time **Sprinkler System** is designed to aid in the cooling of Birds in a Poultry Broiler House. Using the equipment for purposes other than specified in this manual may cause personal injury and/or damage to the equipment.

A Cool, unstressed Bird is more likely to want water and feed, which promotes growth. Sprinkling birds causes them to stand up and move, which releases heat that is trapped between them and the litter into the air that can be removed from the building with ventilation.

Specifications

There are two types of Sprinkling Systems.

- Simultaneous, Whole House Sprinkling System w/1" water supply line hook up.
- Sequential (Zone by Zone) Sprinkling System with Doser Hook-up, and 3/4" water supply line hook up.

Important! Chore-Time does not recommend using the Sprinkling System for spraying Corrosive or harmful chemicals into the house. Corrosive chemicals may cause damage to equipment in the house. Chore-Time is not responsible for any corrosion caused by sprinkling chemicals.

Water Supply Recommendations

Chore-Time recommends enough water flow and pressure to the Control Panels to maintain a 30 PSI [2.07 BAR] outgoing pressure during sprinkling.

Each Sprinkler head will dispense 14 gallons [53 Liters] per hour @30 PSI [2.07 BAR] or .233 Gallons [.88 Liters] per minute at 30 PSI [2.06 BAR].

Water flows and pressures should be adjusted accordingly.

Example Calculations

$$.233 \text{ gallons} \quad (X) \quad \text{Number of Sprinklers to operate at one time} = \text{Minimum Gallons per minute required @ 30 PSI}$$

$$[.88 \text{ Liters}] \quad (X) \quad \text{Number of Sprinklers to operate at one time} = \text{Minimum Liters per minute required @ [2.06 BAR]}$$

Features

1. Pre-assembled Control Panels for 2,3, or 4 Zone applications.
2. Simple Programming using CHORE-TRONICS Controls.
3. Sprinkling based on actual House temperatures.
4. Simple, low voltage Electronic Controls.
5. Relatively low pressure System.
6. Aids in litter management.
7. Low Maintenance system components.
8. Allows dosing the house with needed insecticides.

Planning

Chore-Time offers two types of Control Panels for Sprinkling Systems: Whole House Simultaneous and Zone by Zone Sequential with Doser Hook-up.

Control Panel Location

The Control Panel for either type of system requires a mounting space of 24" x 36" [61cm x 91.4cm].

Warning! Do Not install Control Panel or any water lines above Electrical power sources.

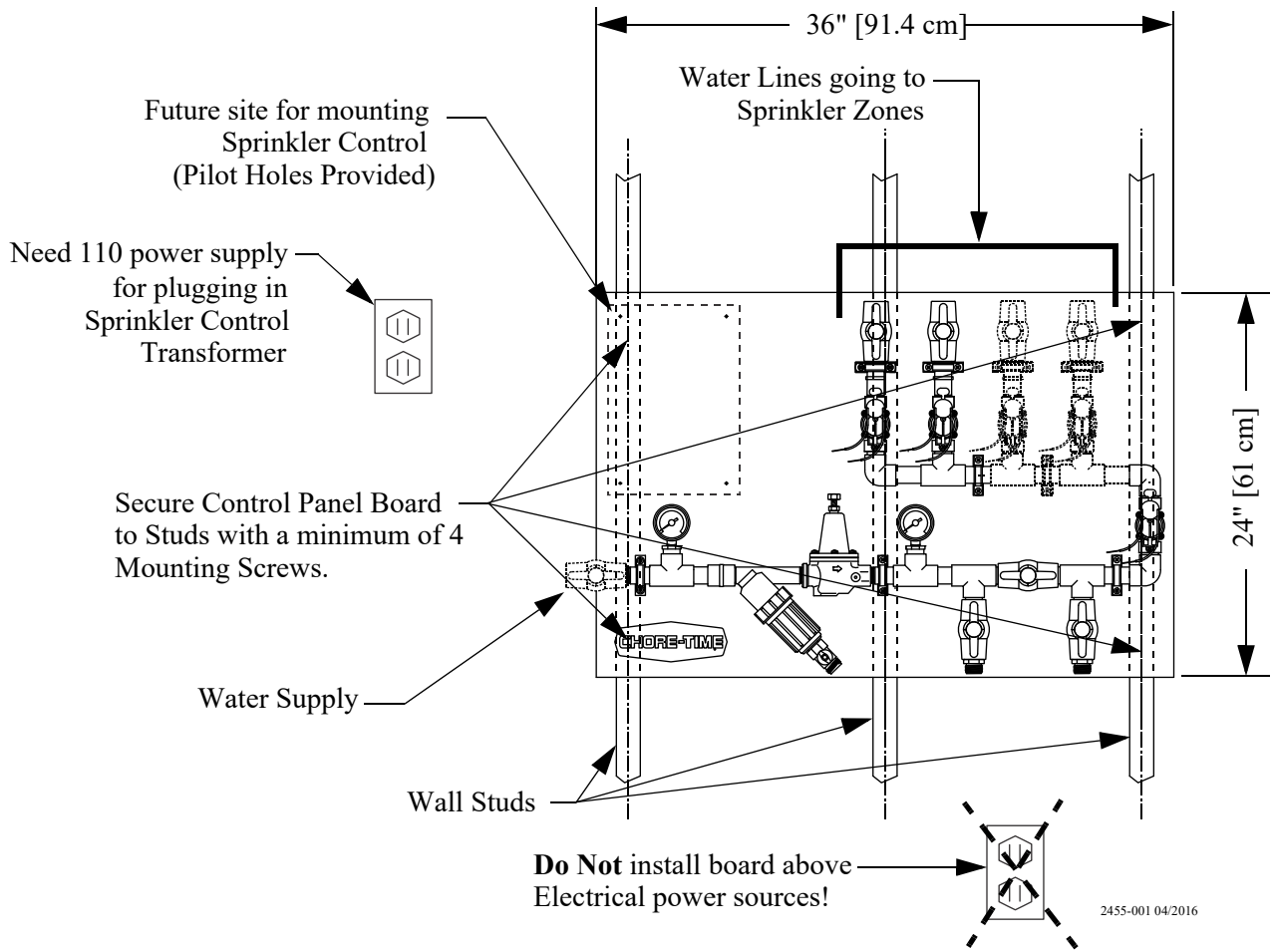

Figure 1.Mounting Planning

Sprinkler Layout

House width determines how many Sprinkler lines are required for coverage.

- Up to 52' [15.8m] - Two Lines
 - 53'- 60'[16.2m - 18.3m] - Three Lines
- Some Example Houses are shown below.

Example Building: 40' [12.2m] wide

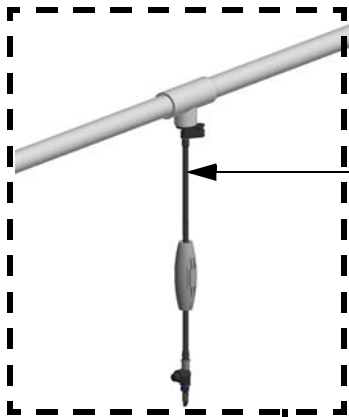
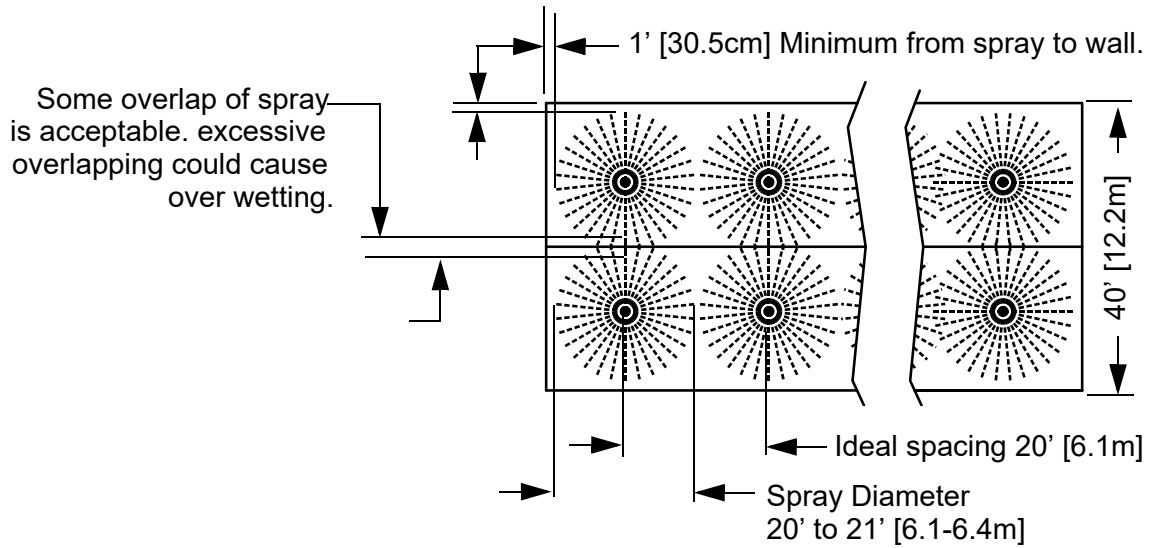

Use Sprinkler Assembly with desired length to achieve optimum height from Litter. Sprinkler Lengths are 12", 18", 24", and 30". [30.5cm,45.7cm,70cm,76.2cm.] See "55644-XX Sprinkler Drop Line Kit (Qty 10 Sprinklers)" on page 19.

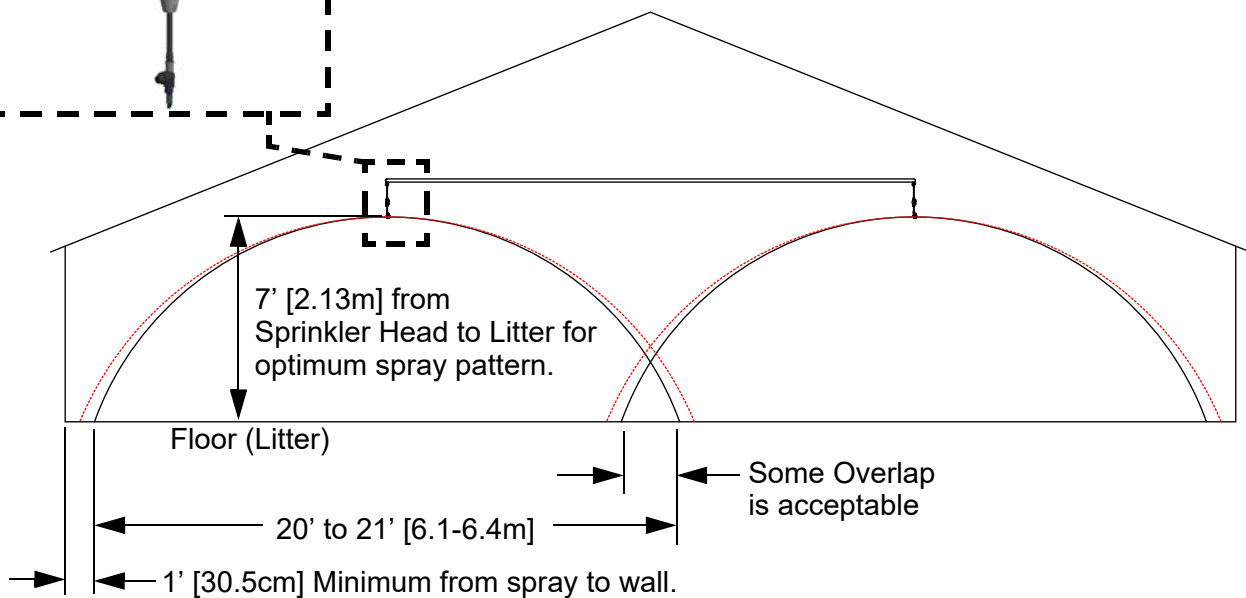
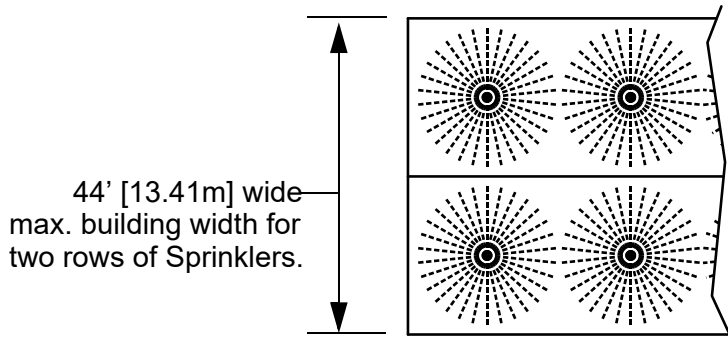
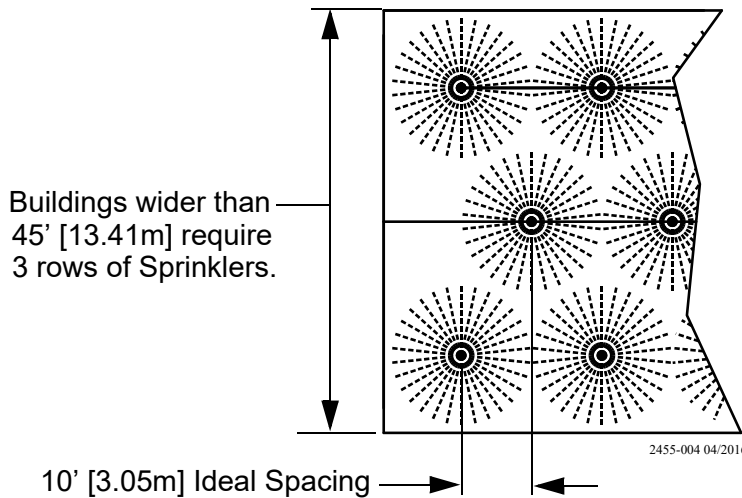

Figure 2.Sprinkler location Layout

Example Building: 44' [13.41m] wide



Example Building: 60' [18.3m] wide



Use Sprinkler Assembly with desired length to achieve optimum height from Litter. Sprinkler Lengths are 12", 18", 24", and 30". [30.5cm, 45.7cm, 70cm, 76.2cm.] See "55644-XX Sprinkler Drop Line Kit (Qty 10 Sprinklers)" on page 19.

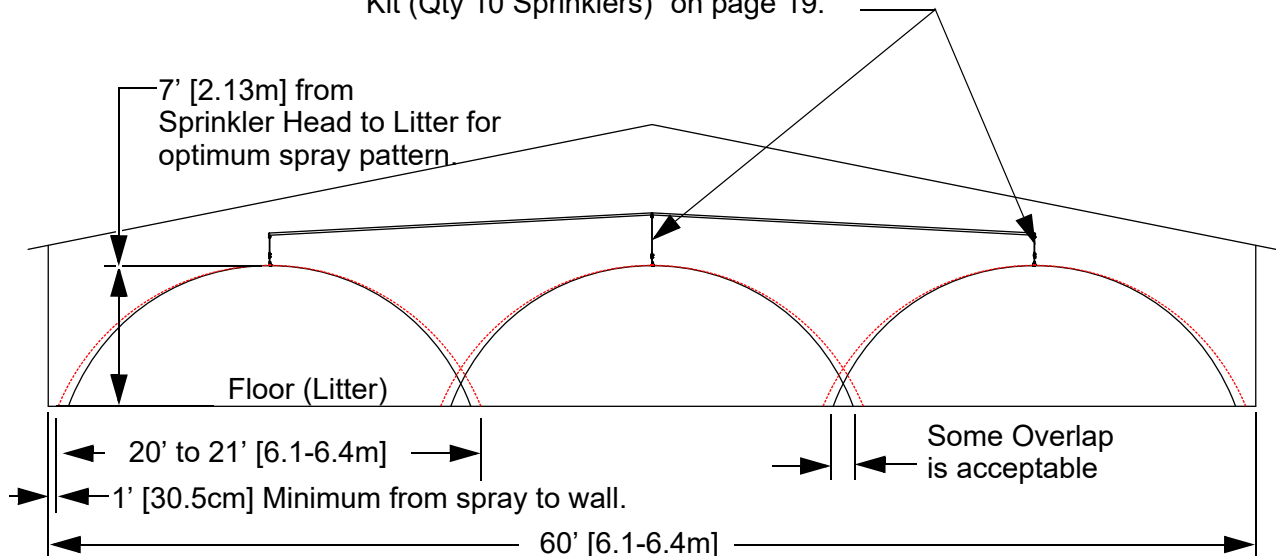

Figure 3.Example 60' [18.3m] Wide House

Plumbing Layout

Warning! Do Not install Control Panel or any water lines above Electrical power sources.

Simultaneous (All at one time) Sprinkling

- 9. Control Panel (55541-X) should be Close to Water Supply and a 115V outlet.
- 10. Use 1" PVC for supply line to the Control Panel and 3/4" lines out to Sprinklers.
- 11. Maximum 25 Sprinklers per Zone.
- 12. Each House Zone needs to have Flush lines.

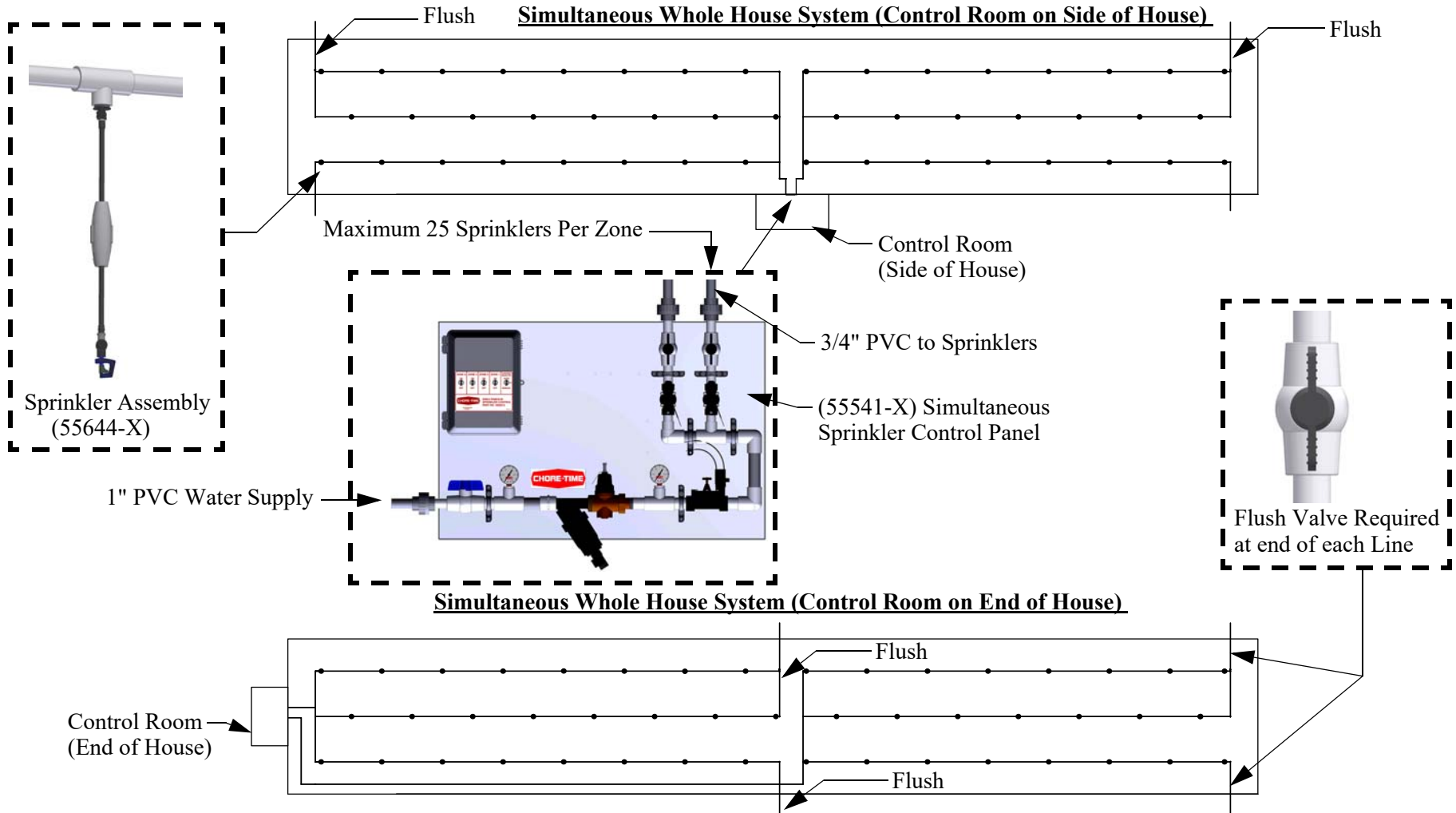

Figure 4. Plumbing Simultaneous System

2455-006 04/2016

Sequential (Zone by Zone) Sprinkling

- 13. Control Panel (55630-X) should be Close to Water Supply and a 115V outlet.
- 14. Use 3/4" PVC for supply to Sprinkler Control Panel and out to Sprinklers.
- 15. Maximum 25 Sprinklers per Zone.
- 16. Each House Zone needs to have Flush lines.

Sequential (Zone by Zone) System (Control Room on Side of House)

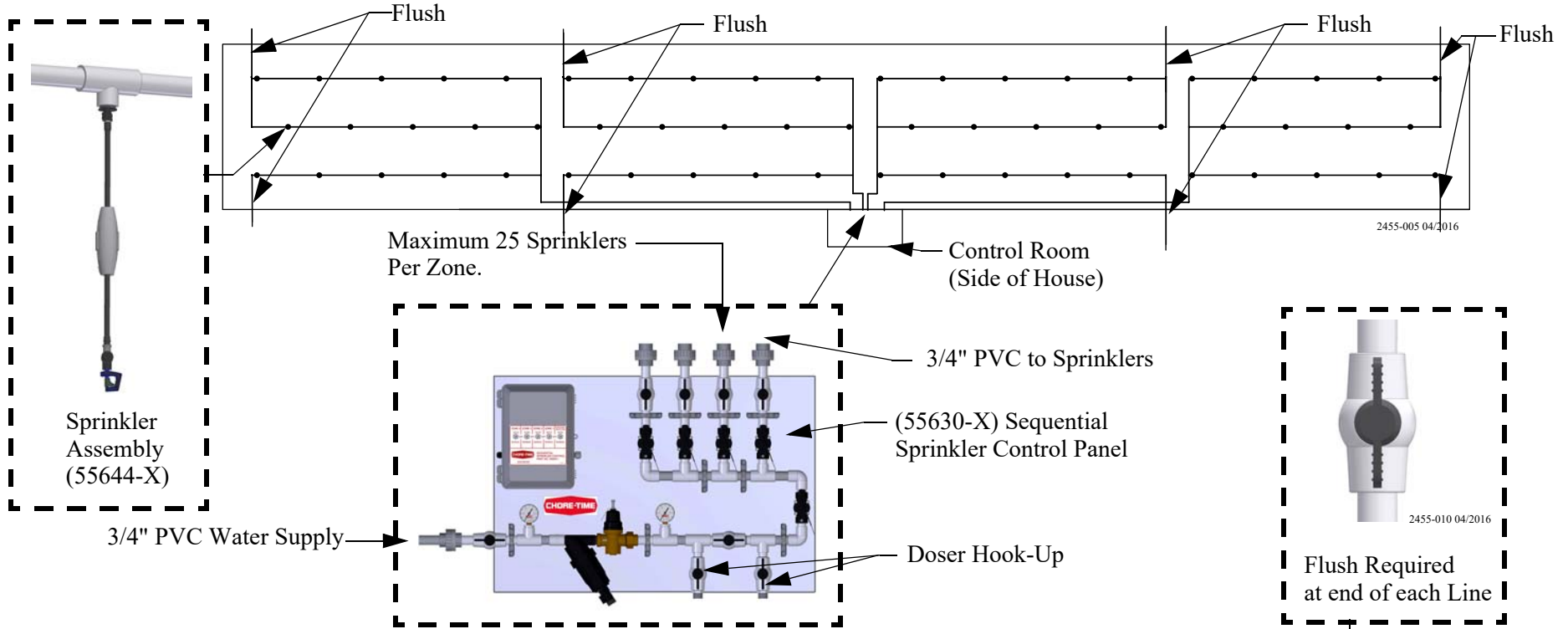

Sequential (Zone by Zone) System (Control Room on End of House)

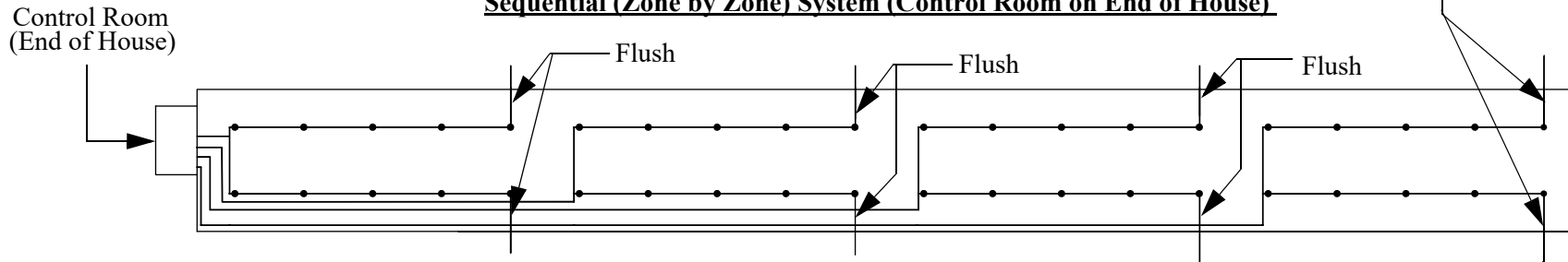

Figure 5.Plumbing Sequential (Zone by Zone) System

2455-005 04/2016

Installation

Control Panel Plumbing

Sequential (Zone by Zone) Control Panel (55630) with Doser Hook-up.

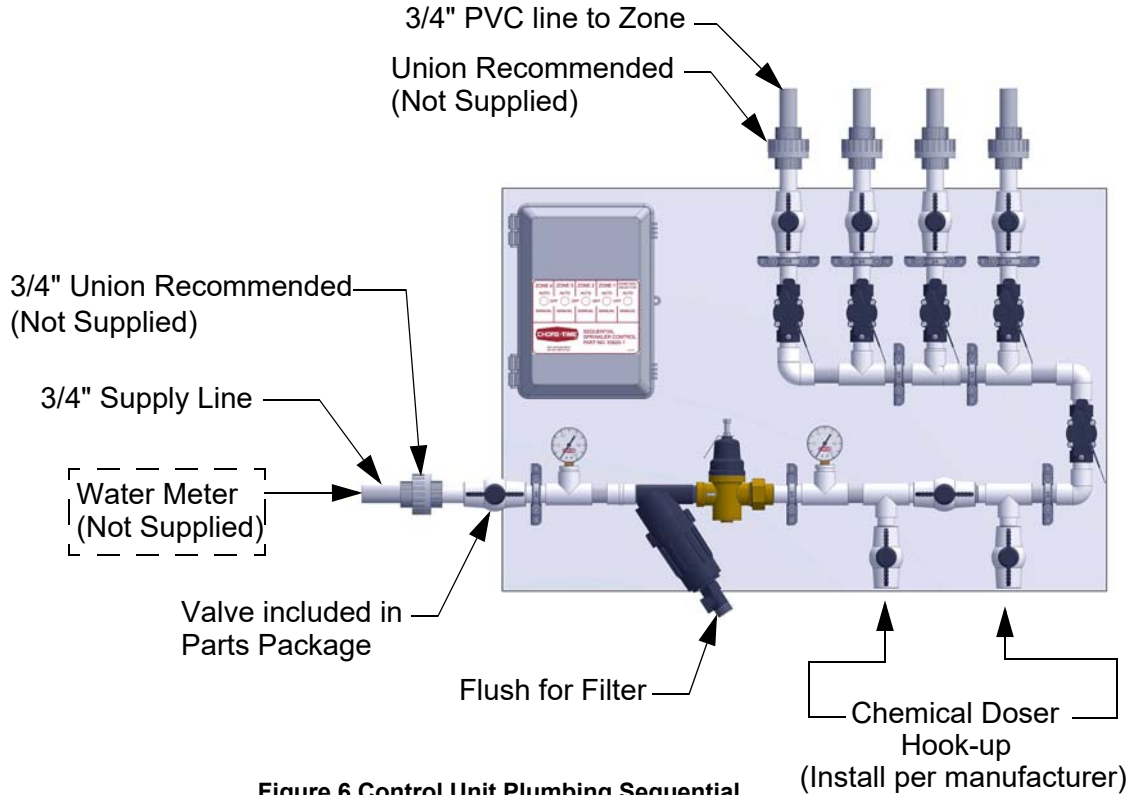

Figure 6. Control Unit Plumbing Sequential

Simultaneous Control Panel (55541-X)

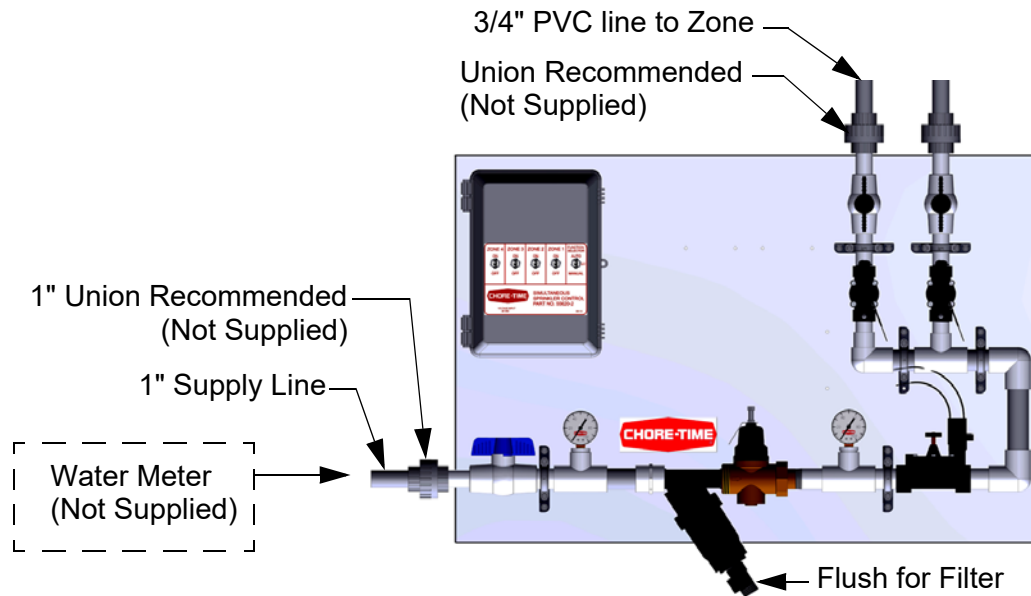

Figure 7. Control Unit Plumbing Simultaneous

Sprinkler Assembly/Plumbing

1. Install the 1/2" MPT x 1/4" Press Fit Adapter (**Item 1**) using Teflon Tape as shown.
2. Install the Sprinkler Drop Tubes (**Item 2**).
3. Do Not install the Non Drip Valve and Sprinkler Heads at this time.

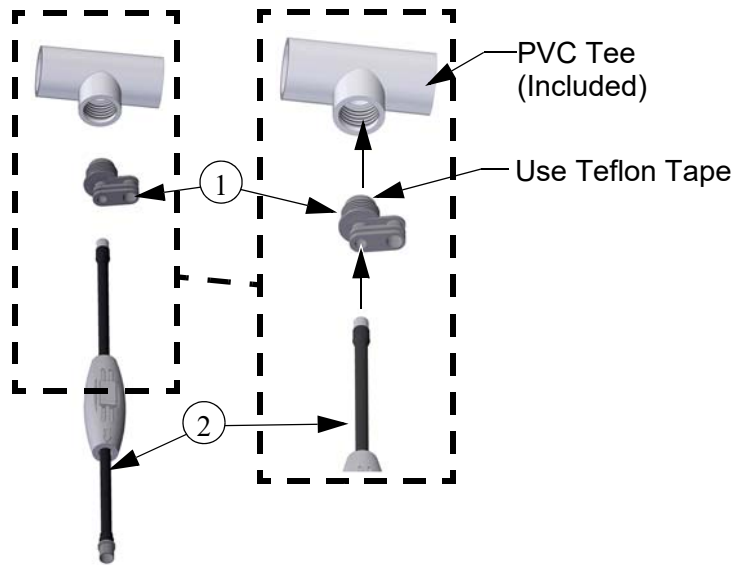

Figure 8.Sprinkler Assembly/Plumbing

Flushing System

Once all of the plumbing is in place, before the system is used the system must be flushed. The System should be flushed one or two lines at a time.

Solenoids at the Control Panel can be operated electronically or manually.

1. Open the Valves at the end of the zone.
2. Open the Master Solenoid on Control Panel.
3. Make sure the Control Panel Valve is open for the zone you want to flush.
4. Use the Solenoid at the Control Panel (See Figure Below) to Operate the zone until water has exhausted from line for at least a few seconds. Solenoids can be operated manually or electronically.
5. Use the Dial to close the Solenoid
6. Close the Flush Valve at the end of the zone.
7. Repeat for each zone desired to flush.

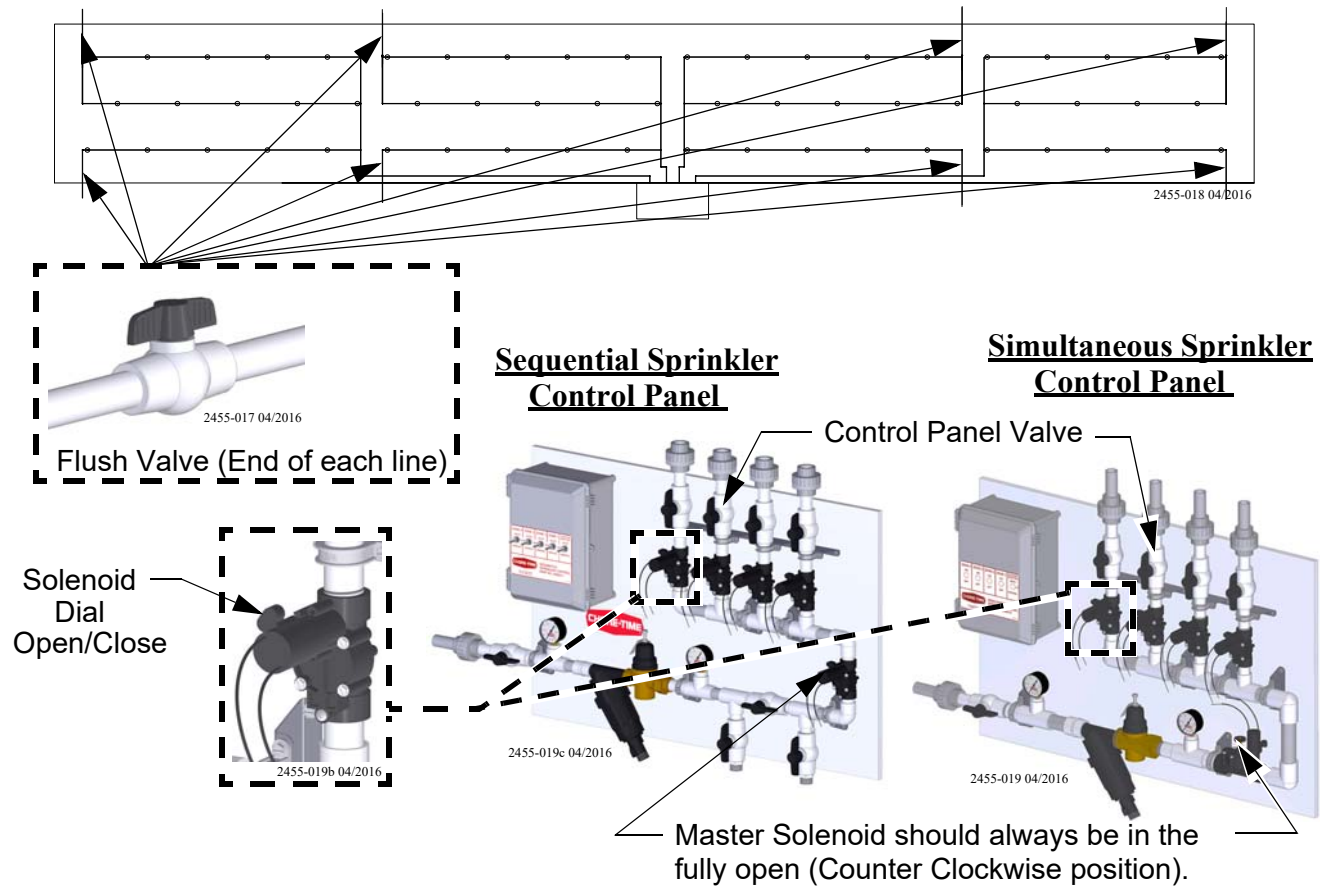

Figure 9.Flushing System

Installing Sprinkler Valves

1. Install the Press Fit Non-Drip Valves and Press Fit Sprinklers as shown.

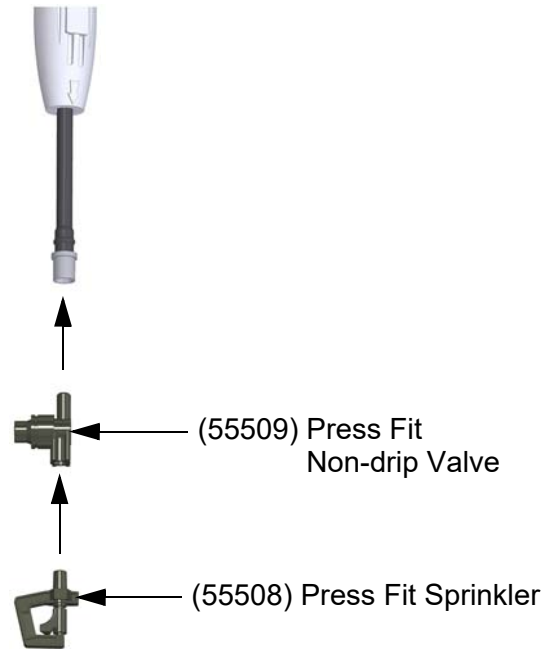

Figure 10. Installing Sprinklers

Control Mounting

1. Mount the Sprinkler Control to the Control Panel using the Pre-drilled Holes as shown.
2. Drill Holes in Control Box and install Liquid Tight Connectors as shown to allow for Wiring.

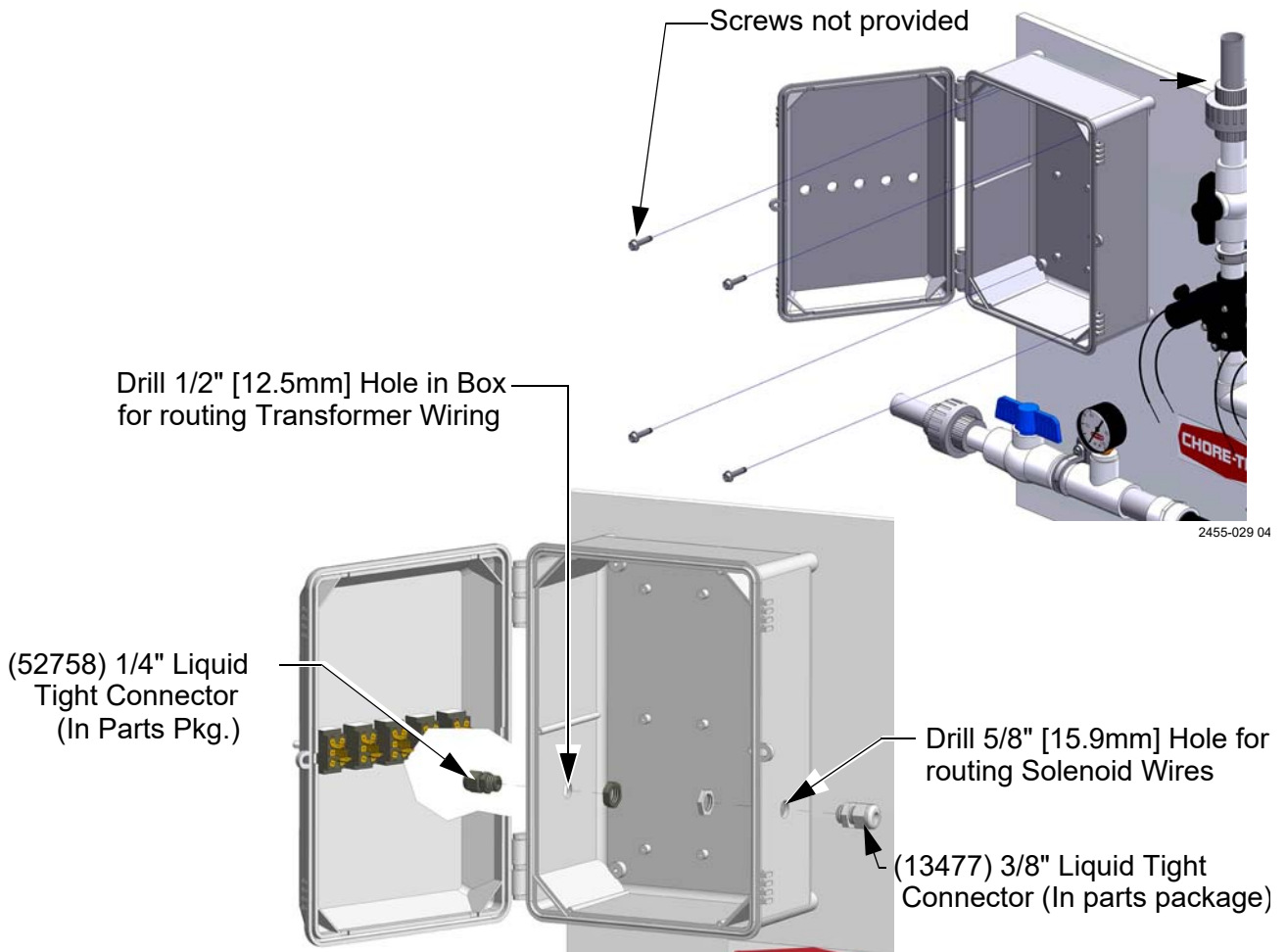

Figure 11. Sprinkler Control Mounting

Operation

Adjusting Water Pressure

The Pressure Regulator should be adjusted to maintain approximately 30 PSI to any one, or all zones operating at one time during the sprinkling cycle.

Flushing

Flush the System at initial startup and after each flock. See “Flushing System” on page 11.

Functionality using Chore-Tronics® 2 and Chore-Tronics® 3

Overview and Requirements

The functionality of the Sprinkler system is controlled using the Cool Outputs and Timers of the Chore-Tronics® Control. There must be 2 Cool Outputs (For example, Cool 1 and Cool 2) along with Timer 1 and Timer 2 to tell the Sprinklers when to run. The two Cool Outputs will be wired to the Sprinkler Control Box.

If not using a Chore-Tronics® Control, the system will require two cooling outputs with each output having its own cycle timer. If it is desired to only have the sprinkler operate during a certain time of the day, a timeclock will be needed to determine when the cooling outputs will be allowed to operate when the ON temperatures are reached.

Setup and Operation

The two Cool Outputs will need to setup to run in Tunnel (T) mode only.

House 1 Setup - Outputs / Relays						
Cool Output	Relay	Mode(s)	Sensor(s)			
Cool 1	-	-	35	T	-234	-----
Cool 2	-	-	36	T	-234	-----
Cool 3	-	-	-			

Figure 12. Cool Outputs set to Tunnel Mode

2455-021 04/2016

If it is desired to only allow the Sprinkler/Cool Outputs to run during a certain period of the day, this can also be entered in the setup screen.

Cool Outputs:
 Cool outputs disabled above RH %
 Allow Cool outputs from to
 Do not allow Cool to go below

Figure 13. Sprinkler Run Time

2455-022 04/2016

In the Outputs and Temperatures Screen, Timer 1 will need to be assigned to Cool 1 and Timer 2 will need to be assigned to Cool 2. This will allow the Cool outputs to cycle on the timers, once their On temperatures are reached.

House 1 Outputs and Temps				
On	Off	Output	Timer	
87.7	86.7	Cool Pad		
85.2	84.2	Cool 2	TIMER 2	
84.2		Tunnel Fan 10		---
83.2	82.2	Cool 1	TIMER 1	
83.2		Tunnel Fan 9		---
82.2		Tunnel Fan 8		---
81.2		Tunnel Fan 7		---

Figure 14. Timer assignments

04/2016

It is recommended to set the On temperatures of the Cool Outputs so that almost all or all Tunnel Fans are already running. This is to ensure that there is adequate airspeed in the house before water sprinkling begins. Cool 2 will need to have an ON temperature that is at least 1 degree Fahrenheit higher than Cool 1.

When the On temperature of Cool 1 is reached, the sprinkler system will put water on the birds at the rate set on Timer 1. When the ON temperature of Cool 2 is reached, the sprinkler system will put water on the birds at the rate set on Timer 2. Also when Cool 2 is functioning, Cool 1 is blocked by the Sprinkler Control Box.

For Timer 1 and Timer 2 setup, it depends on whether the sprinkler system used will turn on all zones on at one time (Simultaneous), or will each zone run sequentially.

Simultaneous Sprinkling

If all zones will be turning on at one time, it is recommended to start Timer 1 with an ON time of 5 seconds and OFF time of 295 seconds (5 seconds out of 5 minutes). Timer 2 should be set with an ON time of 10 seconds and an OFF time of 290 seconds (10 seconds out of 5 minutes)

House 1 Current Settings					
Set Temperature		65.0		Day 90	
					Current Stir On 0
Timer Settings(sec)	On	Off	Tot		Status
Min Ventilation	150	150	05:00		-
Timer 1	5	295	05:00		-
Timer 2	10	290	05:00		-
Stir On	60				NA

2455-024 04/2016

Figure 15.Simultaneous

Sequential Sprinkling

If each zone will run sequentially (and there are 4 zones), it is recommended to set Timer 1 with an ON time of 26 seconds and an OFF time of 274 seconds. Timer 2 will have an ON time of 52 seconds and an OFF time of 248 seconds. These settings allow each zone to run for 5 seconds or 10 seconds with a 2 second pause in between each zone respectively. For the 10 second run time, the 52 second ON time allows the sprinkler system to complete two-5 second cycles with a 2 second pause in between each cycle. If these settings need to be adjusted than it must be done in 5 second intervals per zone. For example, If each zone needs to be on for 15 seconds out of 5 minutes and there are 4 zones, then the ON time will need to 78 seconds and the OFF time will be 226 seconds.

Important: These settings are a starting point recommendation only. On times and temperatures may need to be adjusted based on Bird Age and House conditions. It is also recommended not to use the sprinkler system until birds are at least 21 days of age.

House 1 Current Settings					
Set Temperature		65.0		Day 90	
					Current Stir On 0
Timer Settings(sec)	On	Off	Tot		Status
Min Ventilation	150	150	05:00		-
Timer 1	26	274	05:00		-
Timer 2	52	248	05:00		-
Stir On	60				NA

2455-025 04/2016

Figure 16.Sequential (4 Zones)

If not using a Chore-Tronics® Control, the system will require two cooling outputs with each output having its own cycle timer. If it is desired to only have the sprinkler operate during a certain time of the day, a Time clock will be needed to determine when the cooling outputs will be allowed to operate when the ON temperatures are reached.

Maintenance

Flushing System

1. Zone lines should be flushed between each bird flock. See “Flushing System” on page 11.
2. Control Panel Filter should be flushed whenever the set pressure across the Pressure Regulator begins to decrease, or after each flock.

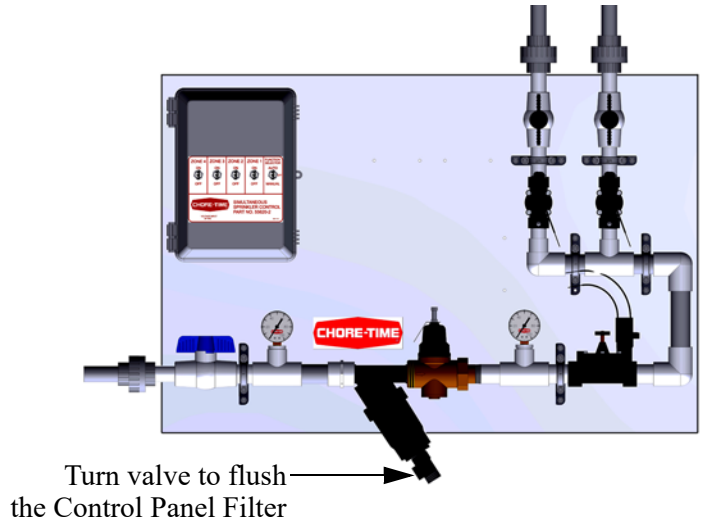

Figure 17. Control Panel Filter

3. If a Sprinkler Head drips after a sprinkler cycle has ended, do the following...
 - Clear the Sprinkler head of debris by applying light air pressure (15 to 20psi) to the Outlet side of the Non-drip Valve.
 - If clearing the Non-drip Valve of debris does not stop a drip, then replace the Valve.

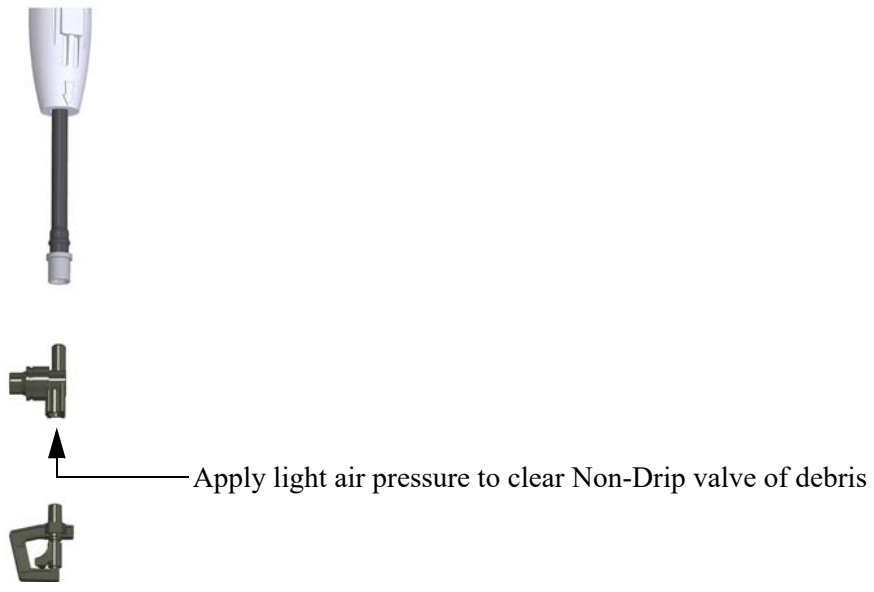
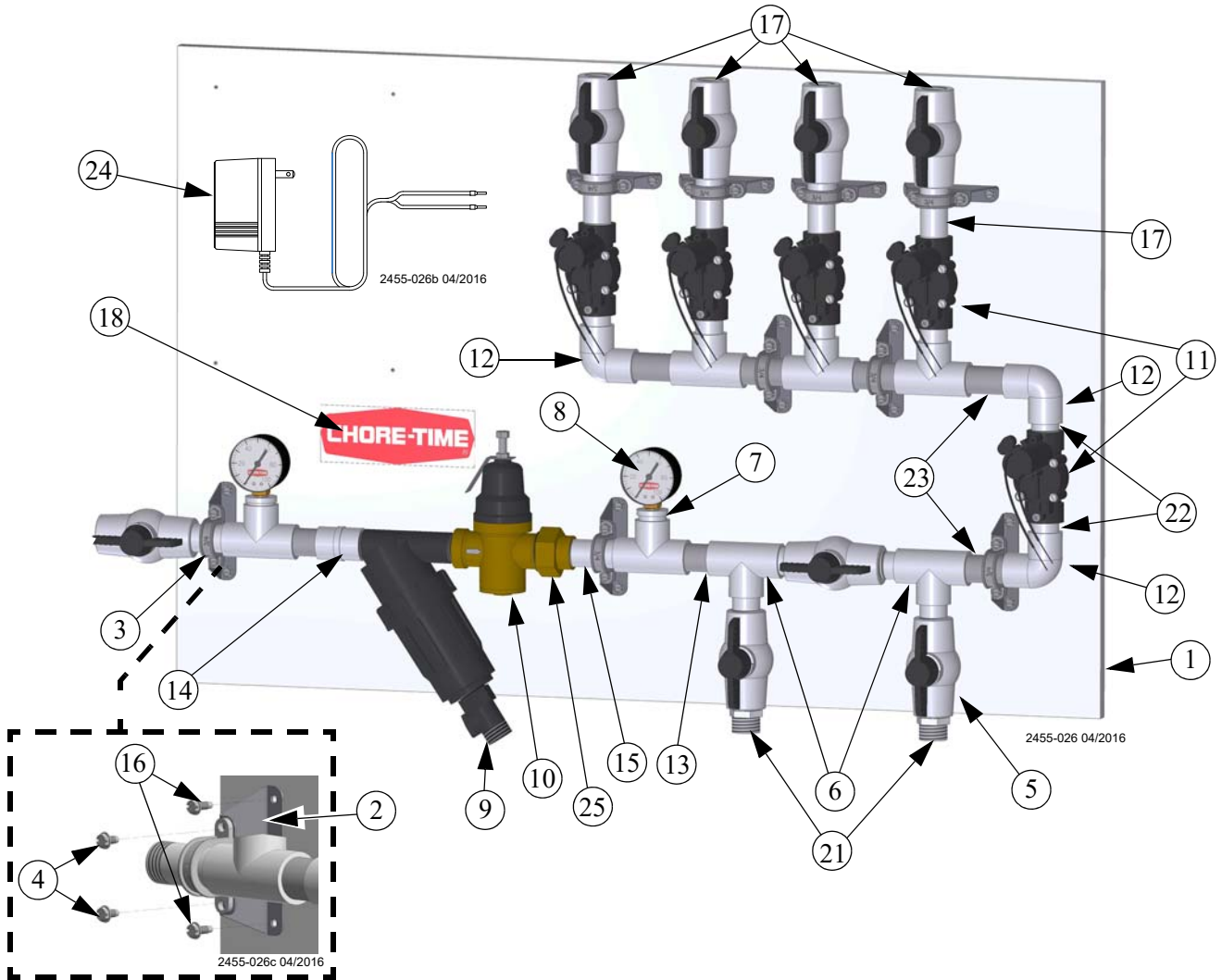

Figure 18. Clear Non-drip Valve of debris

Parts Listing

55630-X Sequential (with Doser Hookup) Sprinkler Control Panel



Item	Description	Part No.
1	Mounting Board	55553-1
2	3/4 Stand Off Bracket	55584
3	3/4 Plastic Conduit Clamp	35301
4	Wshr H Sftp #10-32 X 3/8 Screw	36115
5	Pvc .75-14 Threaded Valve	35781
6	3/4 PVC SxSxS Tee	7538
7	SxFT .75 x .25 Reducer Bushing	7789
8	Water Pressure Gauge	7191
9	Water Filter	55511
10	Regulator	29951
11	.75 Solenoid Flush Valve	40763
12	.75 PVC SxS Ell	8141

Item	Description	Part No.
13	.75 x 2.50 PVC Gray Pipe	29107-5
14	3/4 SxFT Female PVC Adapter	8160
15	3/4 x 3 Sch 80 Pipe	7531-1
16	#10 Twin Helix Screw	28075
17	3/4 x 3 Nipple	55538
18	CT Decal	2525-4
21	3/4 Nylon Adapter	7543
22	3/4 x 1.75 Sch 80 Pipe	7531-12
23	3/4 x 3.20 PVC Gray Pipe	29107-13
24	Transformer	55741
25	3/4 Single Union	55737
55630-2 (2 Zone), 55630-3 (3 Zone), 55630-4 (4 Zone)		

55541-X Simultaneous Sprinkler Control Panel

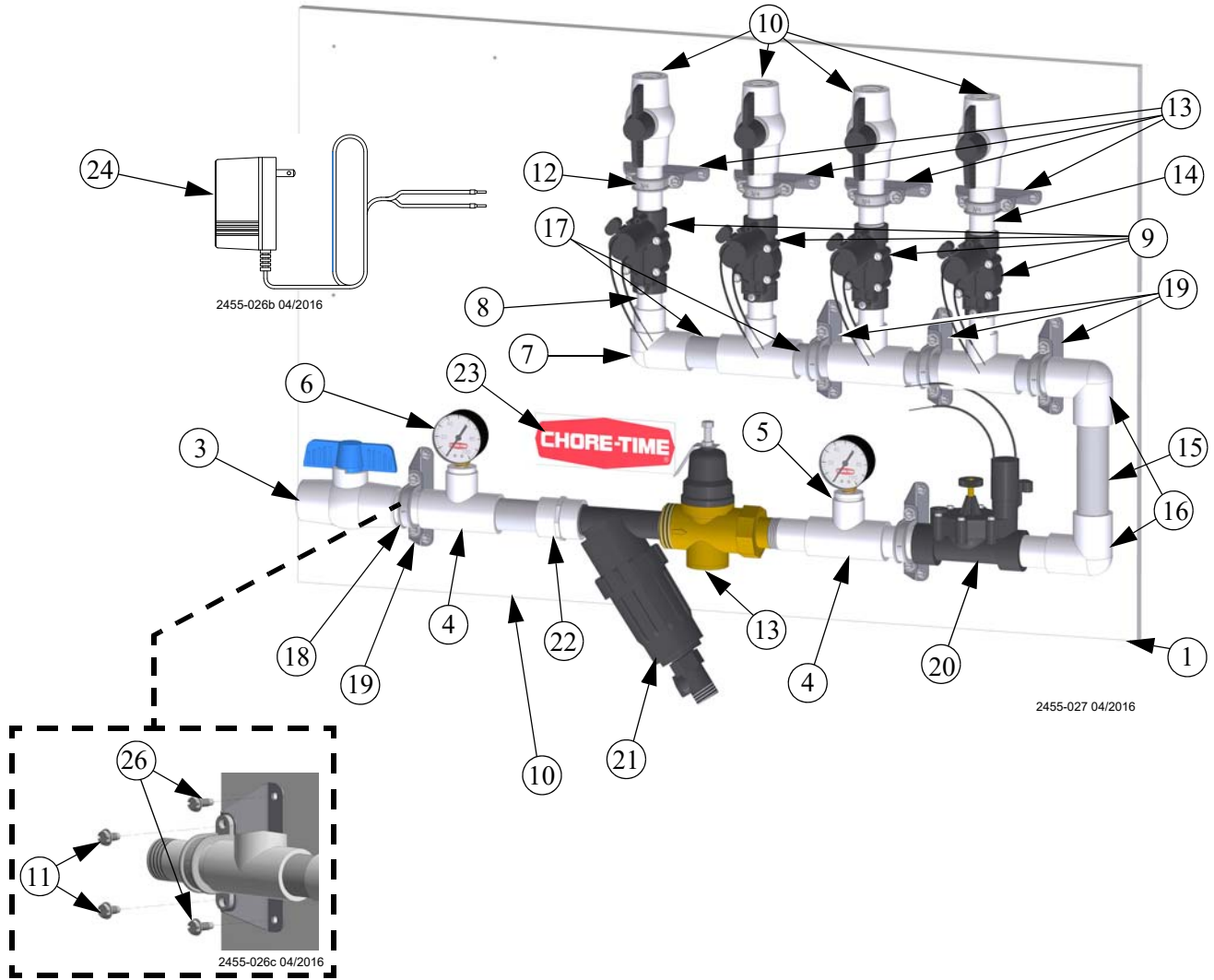

Item	Description	Part No.
1	Mounting Board	55553-2
2	1" x 3 Sch 80 Pipe	55552-1
3	1" (FPT x FPT) PVC Valve	55551
4	1 x 1 x .75 (SxSxS) PVC Tee	55550
5	SxFT .75 x .25 Reducer Bushing	7789
6	Water Pressure Gauge	7191
7	1" x .75 (SxS) Ell	55549
8	3/4 x 1.75 Sch 80 Pipe	7531-12
9	.75 Solenoid Flush Valve	40763
10	PVC .75-14 Threaded Valve	35781
11	Wshr H Sftp #10-32 X 3/8 Screw	36115
12	3/4 Plastic Conduit Clamp	35301
13	3/4 Stand Off Bracket	55584

Item	Description	Part No.
14	3/4 x 3 Nipple	55538
15	1 x 6 Gray PVC Pipe	55547-3
16	1" (SxS) Ell	55548
17	1 x 3.5 Gray PVC Pipe	55547-2
18	1" Plastic Conduit Clamp	55546
19	1" Standoff Bracket	55545
20	1" Solenoid Flush Valve	55544
21	1" Water Filter	55543
22	1" (S x FT) Female PVC Adapter	55542
23	CT Decal	2525-4
26	#10 Twin Helix Screw	28075
27	1" Pressure Regulator	55587
28	Transformer	55741
55541-2 (2 Zone), 55541-3 (3 Zone), 55541-4 (4 Zone)		

55644-XX Sprinkler Drop Line Kit (Qty 10 Sprinklers)



		55644-12 12" [30.5 cm] Drop (10 Sprinklers)	55644-18 18" [45.7 cm] Drop (10 Sprinklers)	55644-24 24" [61 cm] Drop (10 Sprinklers)	55644-30 30" [76.2 cm] Drop (10 Sprinklers)
Item	Description	Part No.	Part No.	Part No.	Part No.
1	.75 x .75 x .50 (SxSxFPT) PVC Tee	34777	34777	34777	34777
2	1/2" MPT x 1/4" Press Fit Adapt.	55591	55591	55591	55591
3	Drop Line Assembly	55574-12	55574-18	55574-24	55574-30
4	Non Drip Valve	55509	55509	55509	55509
5	Inverted Press Fit Sprinkler	55508	55508	55508	55508

55620-1 Sprinkler Control (2-4 Zone Sequential)

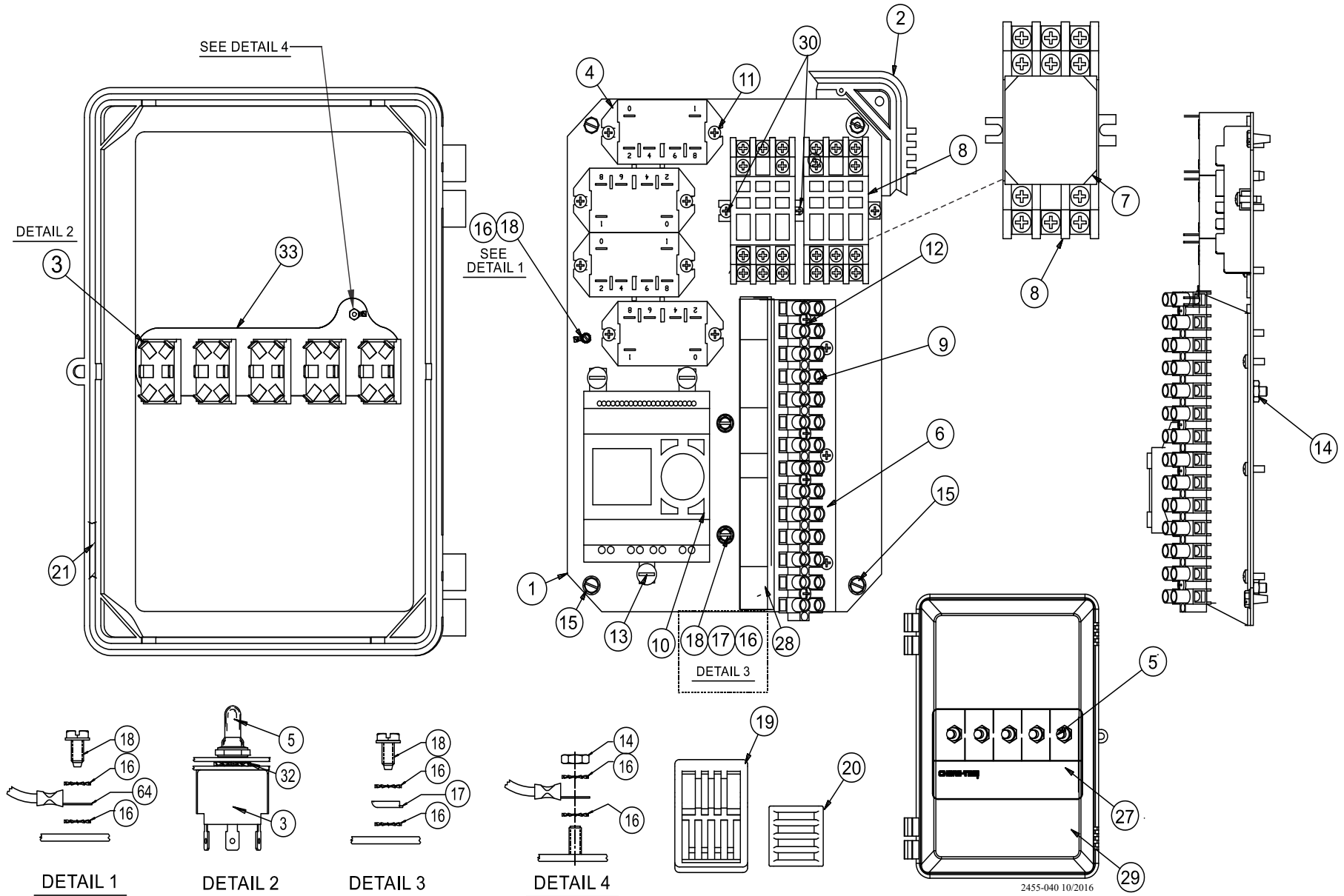

2455-040 10/2016

Item	Description	Part No.
1	Rear Mount Panel	55621
2	8 x 10 Plastic Box	30860-3
3	On Off Switch	20135
4	110 VAC Coil Power Relay	27051
5	Switch Boot	1739
6	Terminal Mounting Bracket	55628
7	Relay	20479
8	Relay Socket	20480
9	7 Pos Terminal Block	34925-7
10	PLC (230V) Programmed Relay	52061-SPK
11	#6-32 SFTP Screw	34660
12	#6-32 x .625 SFTP Screw	34661
13	10-24 x .375 Machine Screw	501
14	10-24 Nut	313
15	#6-32 SFTP Screw	46011
16	#10 Ext. Tooth Lck. Washer	305
17	Cup Washer	5775
18	#10 Green Screw	34662
19	Latch	30862
20	Pivot	30863
21	1/8" Closed Cell Neoprene	34767
27	Control Decal	2529-1158
28	Terminal Block Decal	2529-1160
29	Machined Cover	55629
30	#6-32 x .5 SFTP Screw	35367
32	15/32 Ext. Lock Washer	24671
33	Grounding Panel	55936

22 **55620-2 Sprinkler Control (2-4 Zone Simultaneous)**

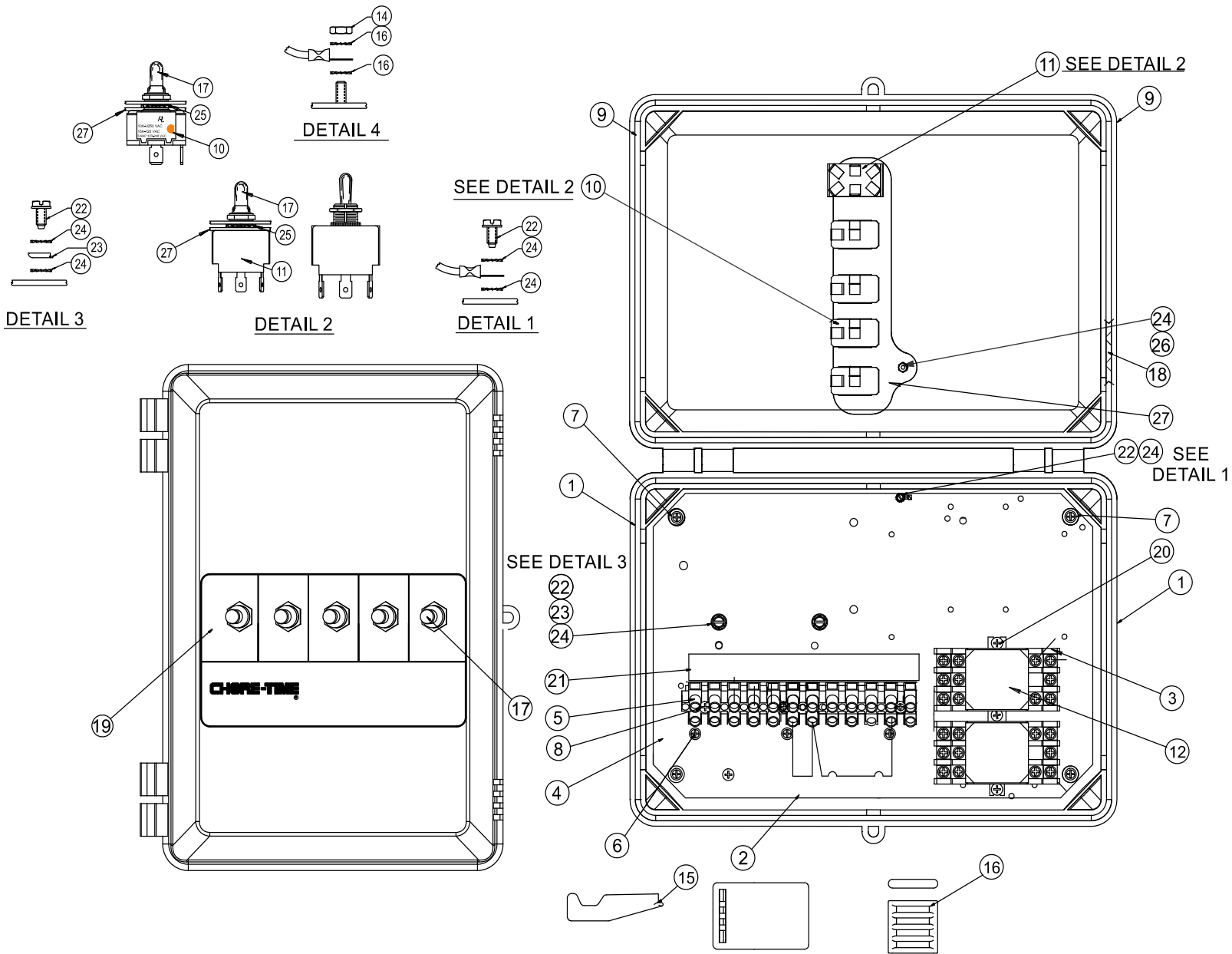

Item	Description	Part No.
1	8 x 10 Plastic Box	30860-3
2	Rear Mount Panel	55621
3	Relay Socket	20480
4	Terminal Mounting Bracket	55628
5	12 Pos Terminal Block	34925
6	#6-32 SFTP Screw	34660
7	#6-32 SFTP Screw	46011
8	#6-32 x .625 SFTP Screw	34661
9	Machined Cover	55629
10	Toggle Switch	48173
11	On Off Switch	20135
12	Relay	20479
15	Latch	30862
16	Pivot	30863
17	Switch Boot	1739
18	1/8" Closed Cell Neoprene	34767
19	Sprinkler Control Decal	2529-1165
20	#6-32 x .5 SFTP Screw	35367
21	Terminal Block Decal	2529-1160
22	#10 Green Screw	34662
23	Cup Washer	5775
24	External Lock Washer	305
25	15/32 Ext. Lock Washer	24671
26	10-24 Nut	313
27	Grounding Panel	55936

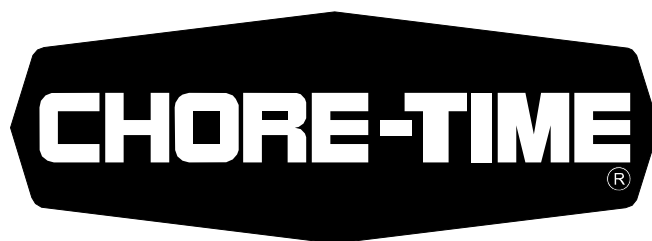

MADE TO WORK.

BUILT TO LAST.®

Revisions to this Manual

Page No.	Description of Change	ECO
4	Added Water supply recommendations	
14	Added "Adjusting Water Pressure"	32117
20-23	Added 55620-1, and 55620-2	

Contact your nearby Chore-Time distributor or representative for additional parts and information.

Chore-Time Group
 A division of CTB, Inc.
 PO Box 2000
 Milford, Indiana 46542-2000 USA
 Phone (574) 658-4101 Fax (877) 730-8825
 E-mail: www.choretimepoultry.com
 Internet: poultry@choretime.com