

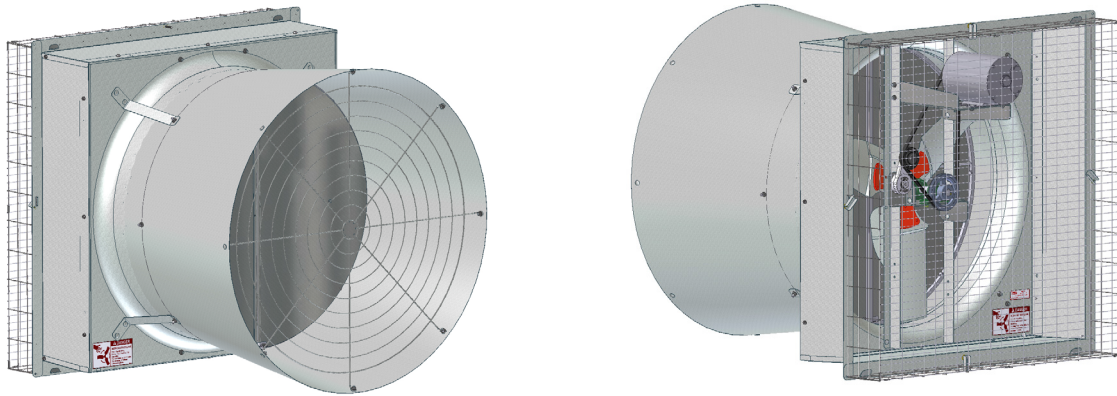

36" Galvanized Belt Drive HYFLO® Fans

Installation and Operators Instruction Manual Fan

Part No. 53096-52



Do Not operate these Fans with a variable speed control device. Operating static pressure should be less than 0.15 inches water column [37.4 pascal].

Safety Information

Carefully read all safety messages in this manual and on your equipment safety signs. Follow recommended precautions and safe operating practices. Keep safety signs in good condition. Replace missing or damaged safety signs.

DANGER: Electrical Hazard

Disconnect electrical power before inspecting or servicing equipment. Ground all electrical equipment for safety. All electrical wiring must be done by a qualified electrician in accordance with local and national electric codes. Ground all non-current carrying metal parts to guard against electrical shock. With the exception of motor overload protection, electrical disconnects and over current protection are not supplied with the equipment.

DANGER: Rotating Fan Blade

Keep Hands away. Disconnect power before servicing. Fan may start automatically. Do not operate the Fan without the screens in place. Disregard to these things will cause serious injury including death.



Warranty

LIMITED WARRANTY

Chore-Time Group, a division of CTB, Inc. ("Chore-Time") warrants new CHORE-TIME HYFLO® Fans manufactured by Chore-Time to be free from defects in material or workmanship under normal usage and conditions, for One (1) year from the date of installation by the original purchaser ("Warranty"). If such a defect is determined by Chore-Time to exist within the applicable period, Chore-Time will, at its option, (a) repair the Product or Component Part free of charge, F.O.B. the factory of manufacture or (b) replace the Product or Component Part free of charge, F.O.B. the factory of manufacture. This Warranty is not transferable, and applies only to the original purchaser of the Product.

CONDITIONS AND LIMITATIONS

THIS WARRANTY CONSTITUTES CHORE-TIME'S ENTIRE AND SOLE WARRANTY AND CHORE-TIME EXPRESSLY DISCLAIMS ANY AND ALL OTHER WARRANTIES, INCLUDING, BUT NOT LIMITED TO, EXPRESS AND IMPLIED WARRANTIES, INCLUDING, WITHOUT LIMITATION, WARRANTIES AS TO MERCHANTABILITY OR FITNESS FOR PARTICULAR PURPOSES. CHORE-TIME shall not be liable for any direct, indirect, incidental, consequential or special damages which any purchaser may suffer or claim to suffer as a result of any defect in the Product. Consequential or Special Damages as used herein include, but are not limited to, lost or damaged products or goods, costs of transportation, lost sales, lost orders, lost income, increased overhead, labor and incidental costs, and operational inefficiencies. *Some jurisdictions prohibit limitations on implied warranties and/or the exclusion or limitation of such damages, so these limitations and exclusions may not apply to you. This warranty gives the original purchaser specific legal rights. You may also have other rights based upon your specific jurisdiction.*

Compliance with federal, state and local rules which apply to the location, installation and use of the Product are the responsibility of the original purchaser, and CHORE-TIME shall not be liable for any damages which may result from non-compliance with such rules.

The following circumstances shall render this Warranty void:

- Modifications made to the Product not specifically delineated in the Product manual.
- Product not installed and/or operated in accordance with the instructions published by the CHORE-TIME.
- All components of the Product are not original equipment supplied by CHORE-TIME.
- Product was not purchased from and/or installed by a CHORE-TIME authorized distributor or certified representative.
- Product experienced malfunction or failure resulting from misuse, abuse, mismanagement, negligence, alteration, accident, or lack of proper maintenance, or from lightning strikes, electrical power surges or interruption of electricity.
- Product experienced corrosion, material deterioration and/or equipment malfunction caused by or consistent with the application of chemicals, minerals, sediments or other foreign elements.
- Product was used for any purpose other than for the care of poultry and livestock.

The Warranty and Extended Warranty may only be modified in writing by an officer of CHORE-TIME. CHORE-TIME shall have no obligation or responsibility for any representations or warranties made by or on behalf of any distributor, dealer, agent or certified representative.

Effective: **April 2014**

Fan and Fan Framing Dimensions

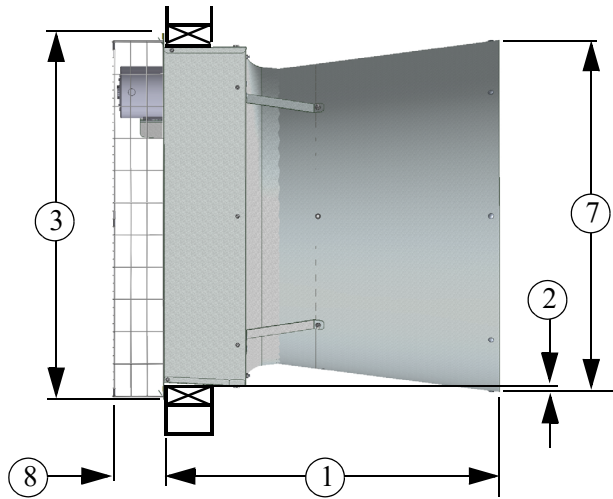

Planning the layout of the spacing between Fans is very important. Spacing too close together will cause interference between the discharge Cones. **The Rough Opening dimensions for Fans are shown above.**

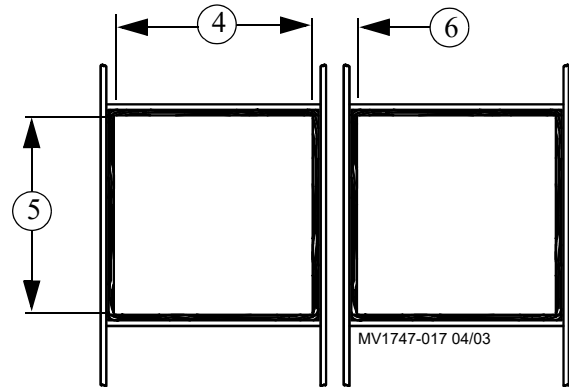

Item	Description	Dimension
1	Bottom Length	41-1/2" [105.41cm]
2	Vertical Dim. of Cone	1" [2.54cm]
3	Height (Outside of Flanges)	45-1/2" [115.57cm]
4	Rough Opening Width	43" [109.22cm]
5	Rough Opening Height	42-1/2 [107.95cm]
6	Minimum Spacing	3-1/2" [8.89cm]
7	Outside Diameter of Cone	43-3/4" [111.13cm]
8	Depth inside Building	6-1/2" [16.51cm]

Figure 1. Fan Dimensions

The Fan Inlet and exhaust must be kept clear of obstructions. Failure to keep the Fan airflow path clear of obstructions could cause loss of Fan performance and Fan damage.

Fan Assembly/Installation

Screen Clips

Set the Fan into the framed opening, but leave it hang out a few inches to allow for the insertion of four Screen Clips (**Item 1, Figure 7**). With the Screen Clips oriented with the tab lock as shown, push them into the slots in the Fan Housing Panels and rotate them forward until they lock into place as shown. Slide the Fan forward flush with the rough opening making sure that the Clips do not fall out.

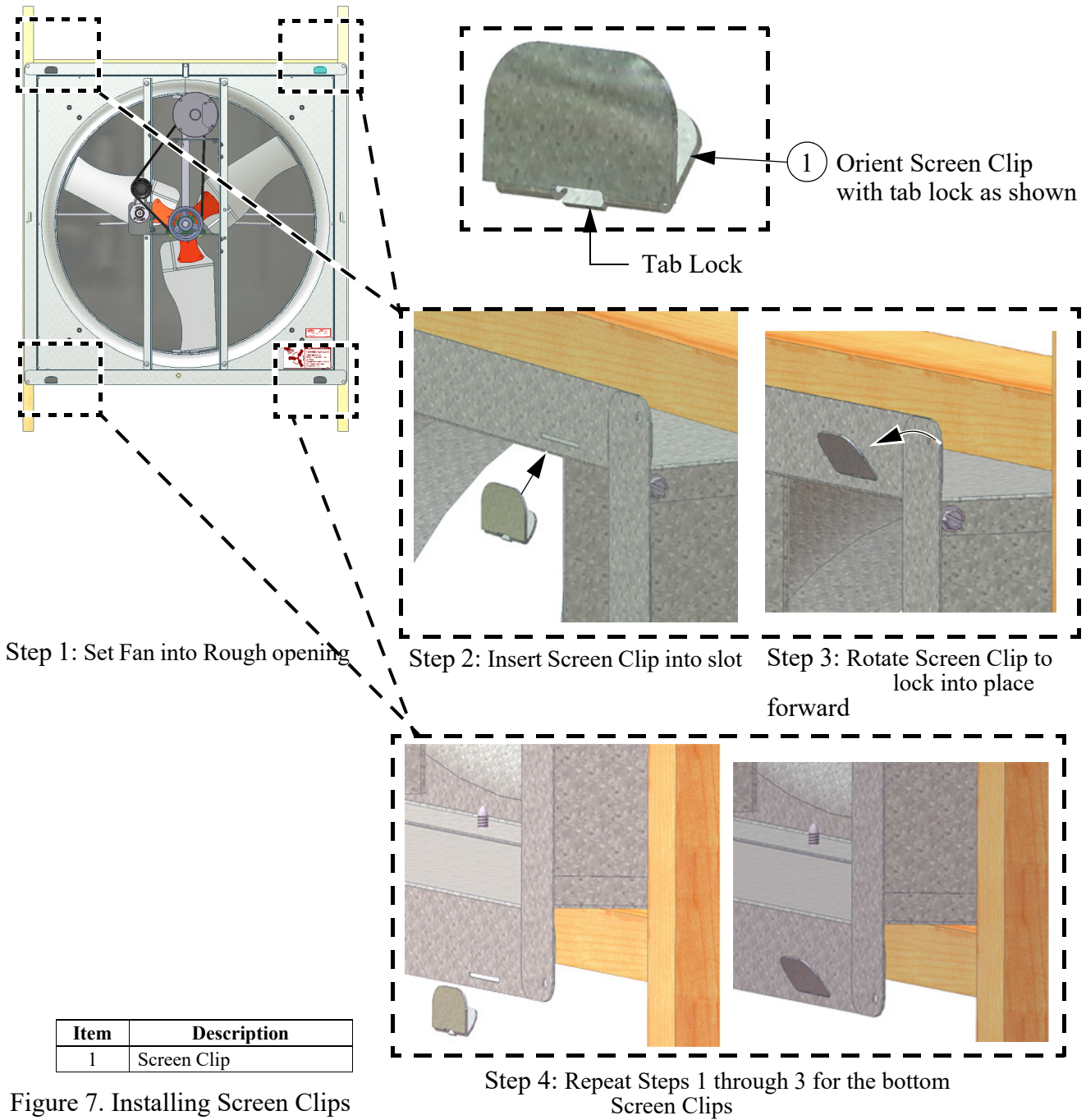

Figure 7. Installing Screen Clips

Attaching the Fan to the Wall

Slide the Fan assembly into the rough opening and starting with the side hole locations (**Detail A**), use 1/4 x 1-3/4" Lag Screws (**Item 1, Figure 8**), two Nylon Washers (**Item 2**), and a Screen Retainer (**Item 3**) to attach the Fan to the Wall as shown. Use 1/4 x 1-3/4" Lag Screws to attach the Fan at the four corners (**Detail B**) as shown.

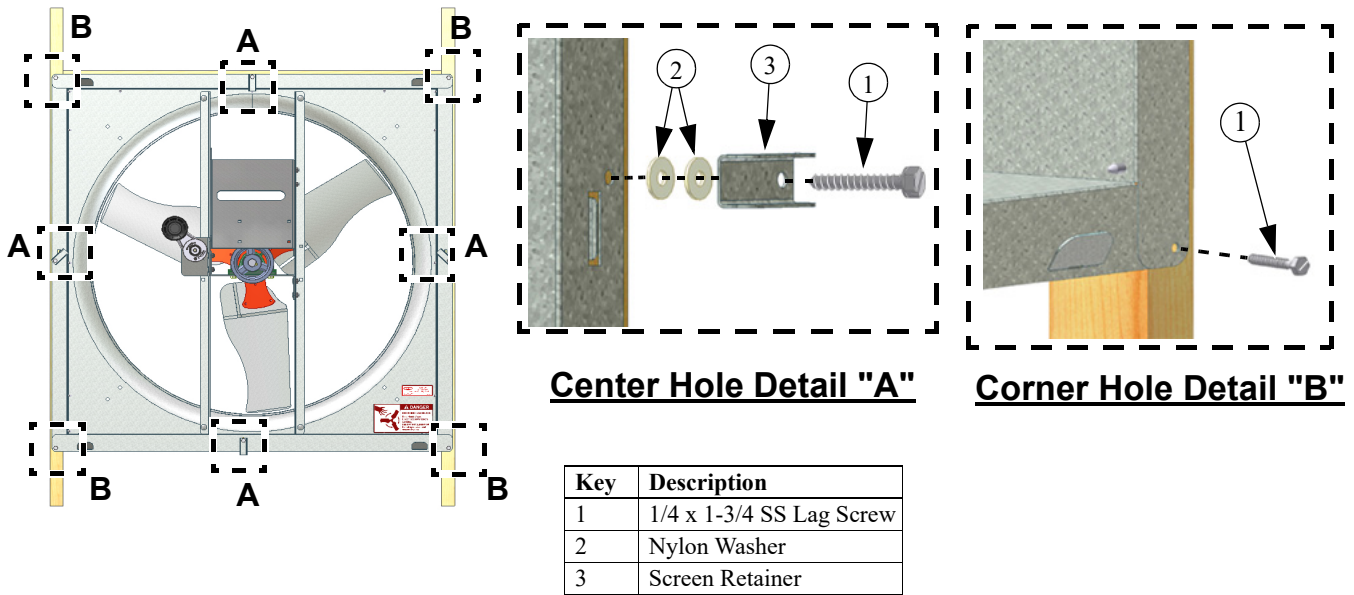

Figure 8. Attaching the Fan to the Wall

Motor Installation

Rotate the Motor Support Bracket into the upright position by removing the **Upper** Carriage Bolt and Nut and loosening the **Lower** Bolt and Nut (See **Figure 9**). Rotate the Motor Support Bracket until it is perpendicular to the Fan Posts and fasten with (4) 5/16 Carriage Bolts and (4) 5/16 Flange Nuts. *Note that the Nuts go outside the Posts.* Remove the Motor from the Crate and attach it to the Motor Support Bracket with (4) 5/16 Carriage Bolts and (4) 5/16 Flange Nuts as shown.

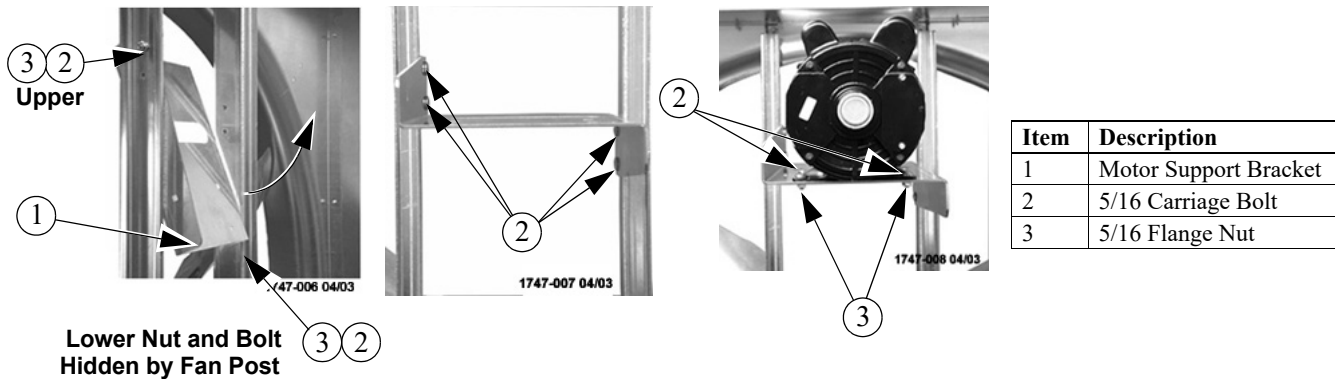

Figure 9. Attaching the Motor Support Bracket and Motor

Belt Installation

Guide the Belt through the Opening in the Motor Support Bracket and loop it over the Motor Sheave. Guide the Belt around the Tensioner Sheave and push on it to get enough slack to put the Belt on the Driven Sheave **as shown in Figure 10**. Make sure the Belt does not rub against the Motor Support Bracket.

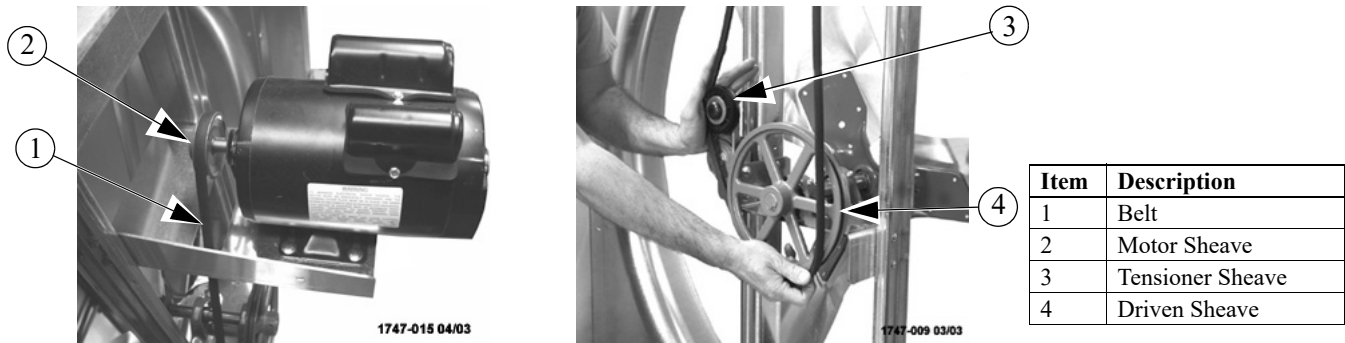
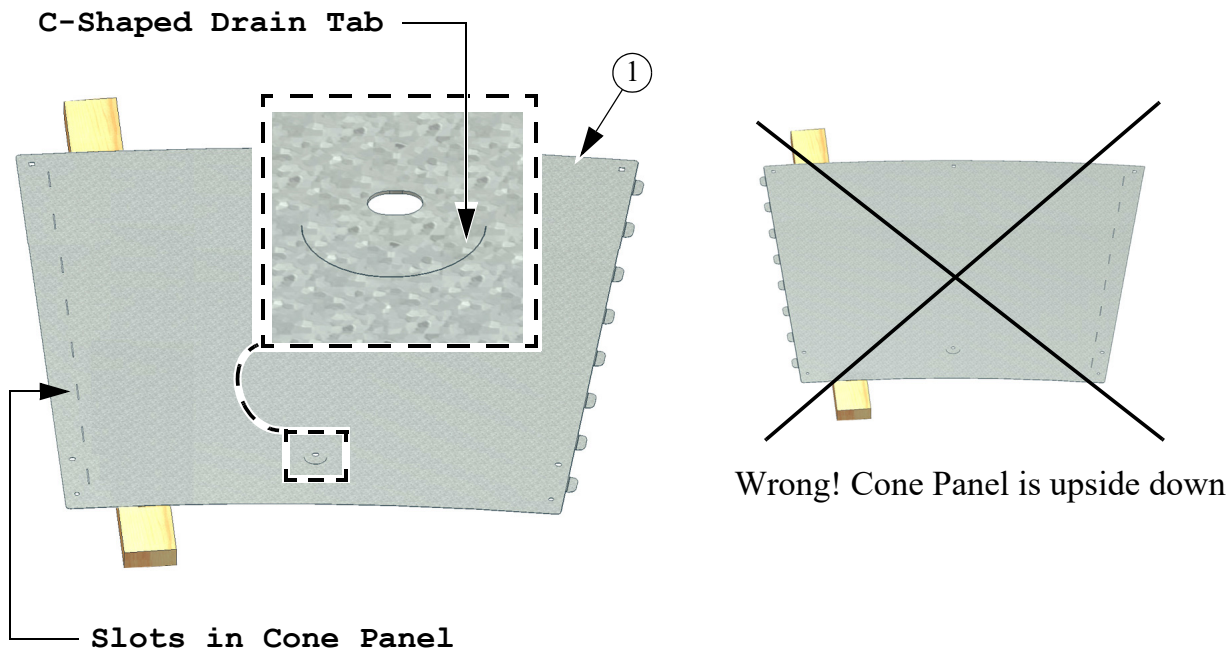

Figure 10. Installing the Belt

Cone Assembly and Installation

Step 1: Lay a Cone Panel down (Drain Tab at the bottom and slots to the left) and Prop the end up (Slotted end) with a 2 x 4 board.



Item	Description
1	Cone Panel

Figure 11. Assembling Cone Panels

Step 2: Insert the Tabs of a second Cone Panel into the slots of the 1st Panel and Lay it down locking the two Panels together.

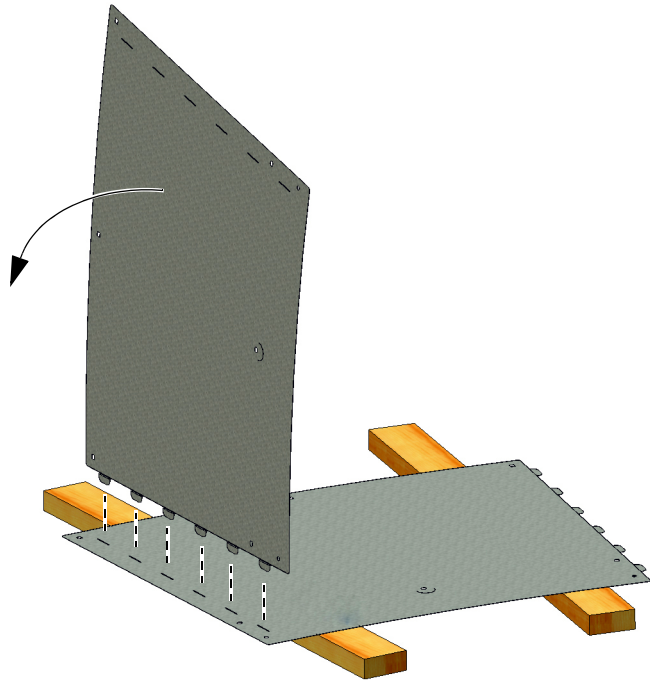

Step 3: Repeat Step 2 until all four Cone Panels are locked together.

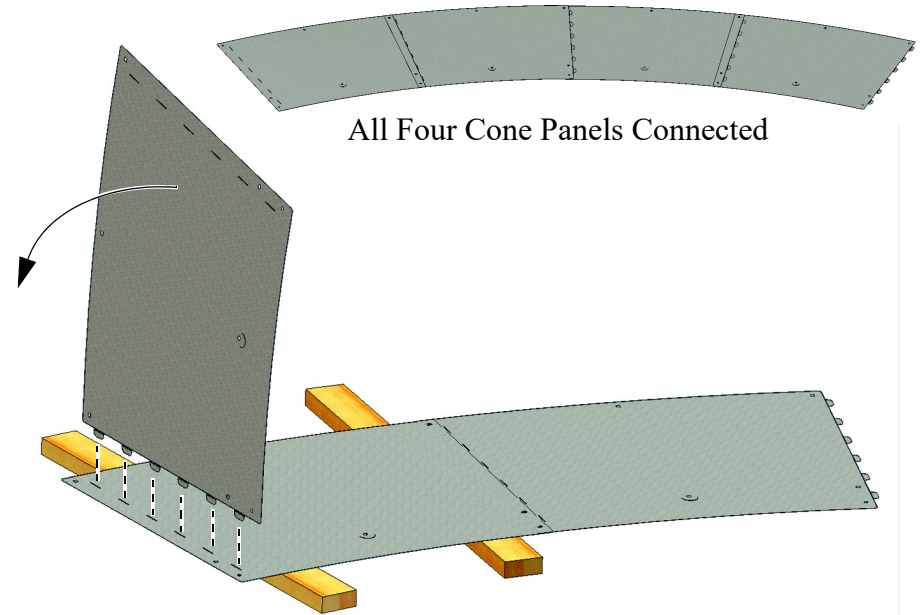

Step 4: Stand the Panels up on edge and curl the Panels around making a Cone shape with the smaller diameter up. Insert the Tabs of the last Panel into the Slots of the 1st and allow the Cone to take its shape.



1747-031 04/03

Step 5: Fasten the Cone Panels together with (4) 5/16" x 1/2" Hex Bolts threaded from inside the finished Cone. Do not tighten down the Nuts at this time. Leave the Nuts loose until the Cone is attached to the Fan.

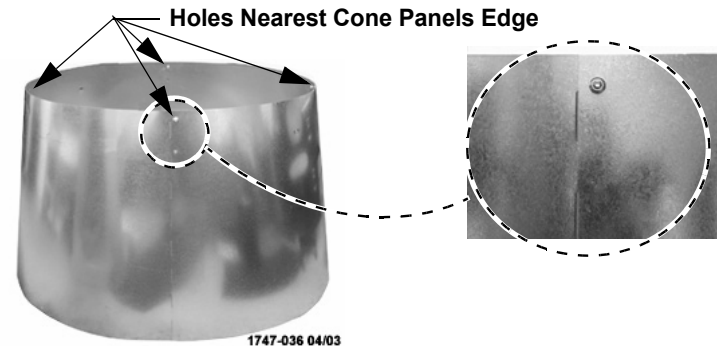

1747-036 04/03

Figure 12. Assembling Cone Panels

Installing Door Assembly

Step 1: Remove Tape (Item 1) holding the Nylon Cable (Item 2) to the Door.

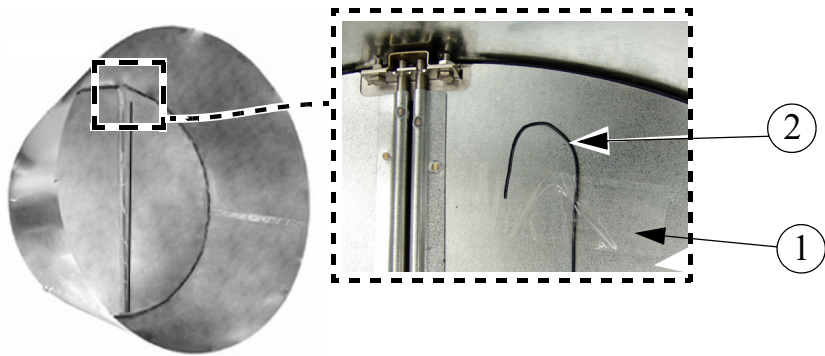

Step 2: Line up the Four Holes in the Door Ring with the holes in the Cone and thread (4) 5/16 x 1-1/4" Bolts (Item 3) in until they are tight. Do not install Nuts at this time. These Bolts will be used later to attach the Cone Brackets to the Cone Assembly.

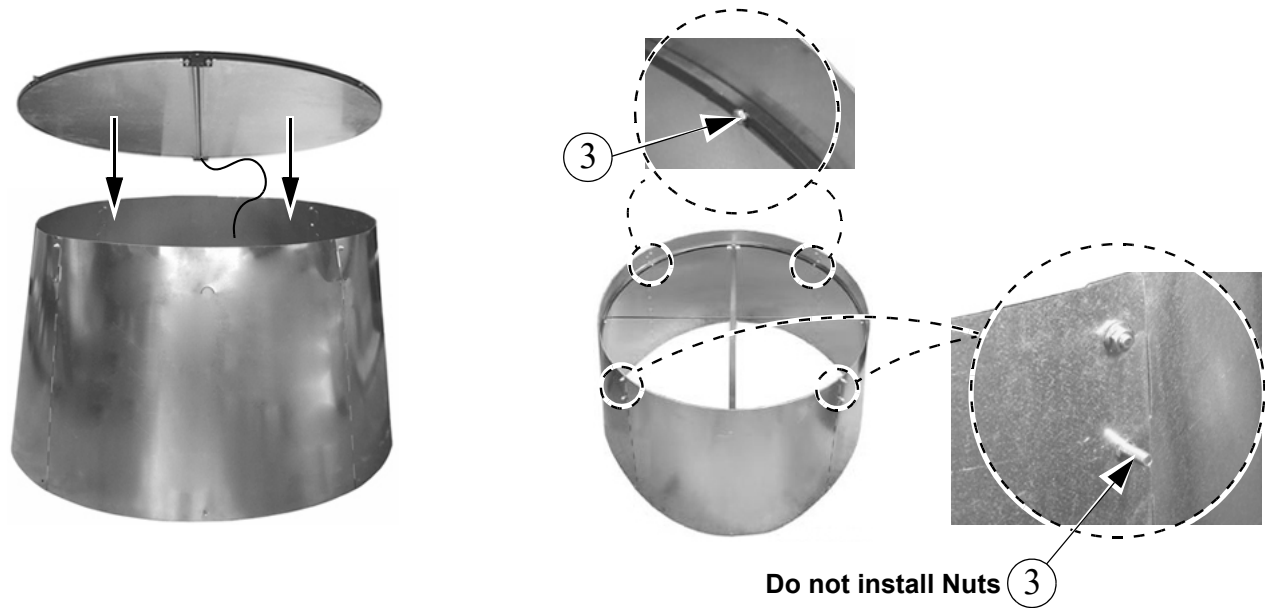

Step 3: Use (2) 5/16 x 1-1/4" Bolts (Item 3) and (2) 5/16" Flange Nuts (Item 4) to attach the Ring to the Cone using the holes located on both sides near the Door Center Brace (Item 5) as shown. The Nuts go outside the Cone.

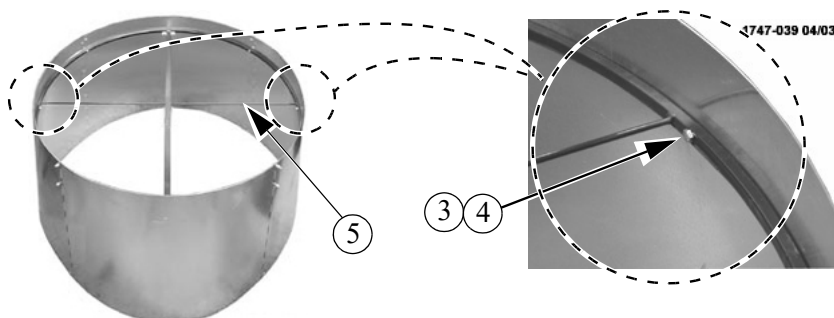

Item	Description
1	Tape
2	Nylon Cable
3	5/16 x 1-1/4" Bolt
4	5/16 Flange Nut
5	Door Center Brace

Figure 13. Installing the Door Assembly

Attaching the Door Stop Cable (Nylon Cable) and Grill.

Step 1: Line up the Grill Eyehooks with the holes in the Cone. Thread the free end of the Nylon Cable (**Item 2**) through the bottom Grill Eyehook (**Item 1**) until it is flush with the Cone and secure it with a 5/16-18 Carriage Bolt (**Item 3**) and Flange Nut (**Item 4**) as shown.

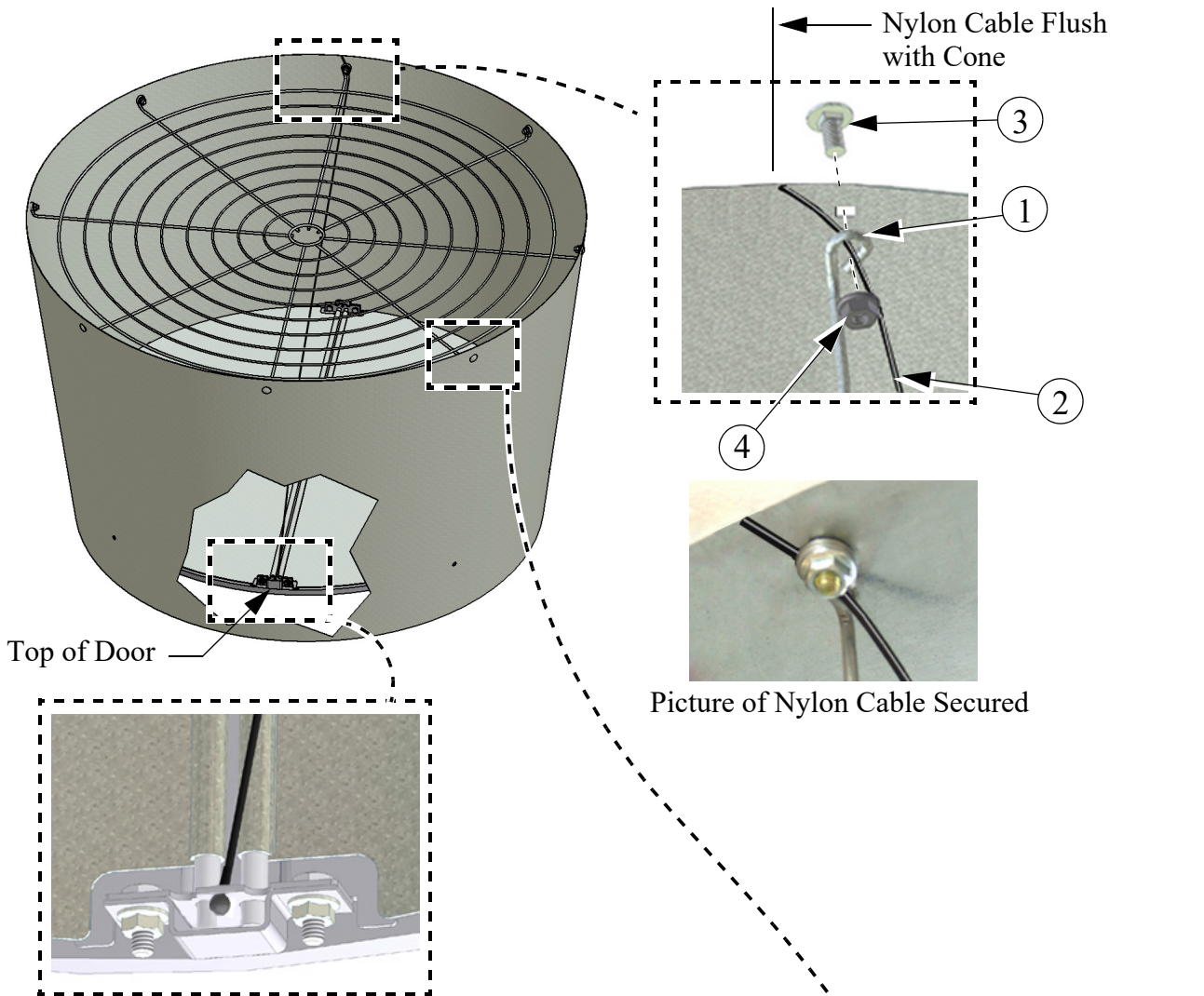

Step 2: Use 5/16 Carriage Bolts (**Item 3**) and Nuts (**Item 4**) to fasten Grill to Cone at remaining 7 locations.

Item	Description
1	Bottom Grill Eyehook
2	Door Stop Cable (Nylon Cable)
3	5/16-18 x .625 Carriage Bolt
4	5/16-18 Flange Nut

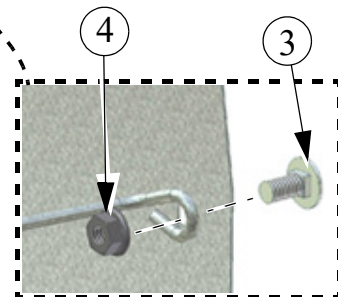
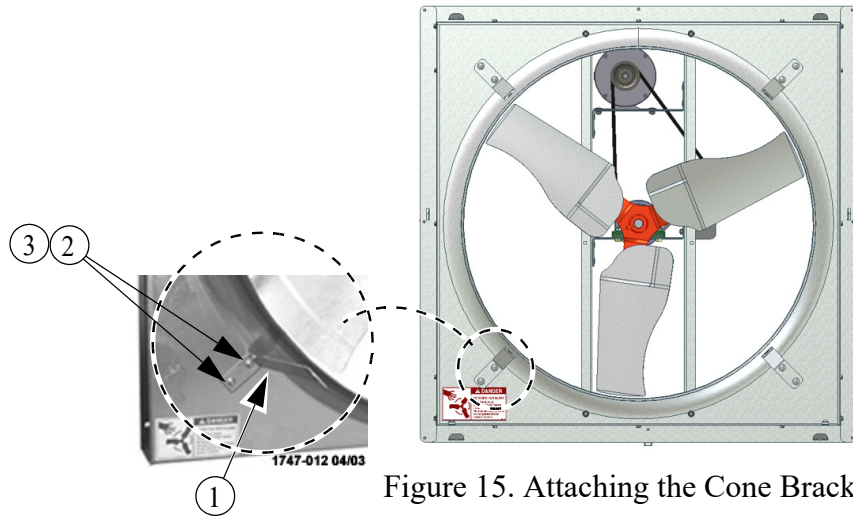

Figure 14. Installing the Door Stop Cable

Assembling the Cone to the Fan

Use 5/16 x 5/8" Carriage Bolts and 5/16 Flange Nuts to attach the **four** Cone Brackets to the Fan Shroud as shown in Figure 15.



Item	Description
1	Cone Bracket
2	5/16 x 5/8" Carriage Bolt
3	5/16 Flange Nut

Figure 15. Attaching the Cone Brackets

Mounting the Cone and Door Assembly on the Fan requires at least two people. Pick up and orient the Cone with the Door Stop Cable (**Item 1, Figure 16**) attached at the top and rest the Cone on top of the Fan Orifice as shown. Attach the top of the Cone to the Cone Brackets (**Item 2**) with the Bolts that were previously threaded through the Ring and Cone and secure with 5/16 Flange Nuts (**Item 3**). Only hand tighten the Nuts at this time. Working around the Fan Orifice from inside the fan, in a circular motion Slide the Cone over the Fan Orifice. The Cone will Fit snug. Use the Bolts previously threaded through the Ring and Cone and the 5/16 Flange Nuts to secure the bottom of the Cone to the Fan as shown. Use a Level and rotate the Cone until the Door center rail is Vertical (See Figure). Now tighten all Hardware.

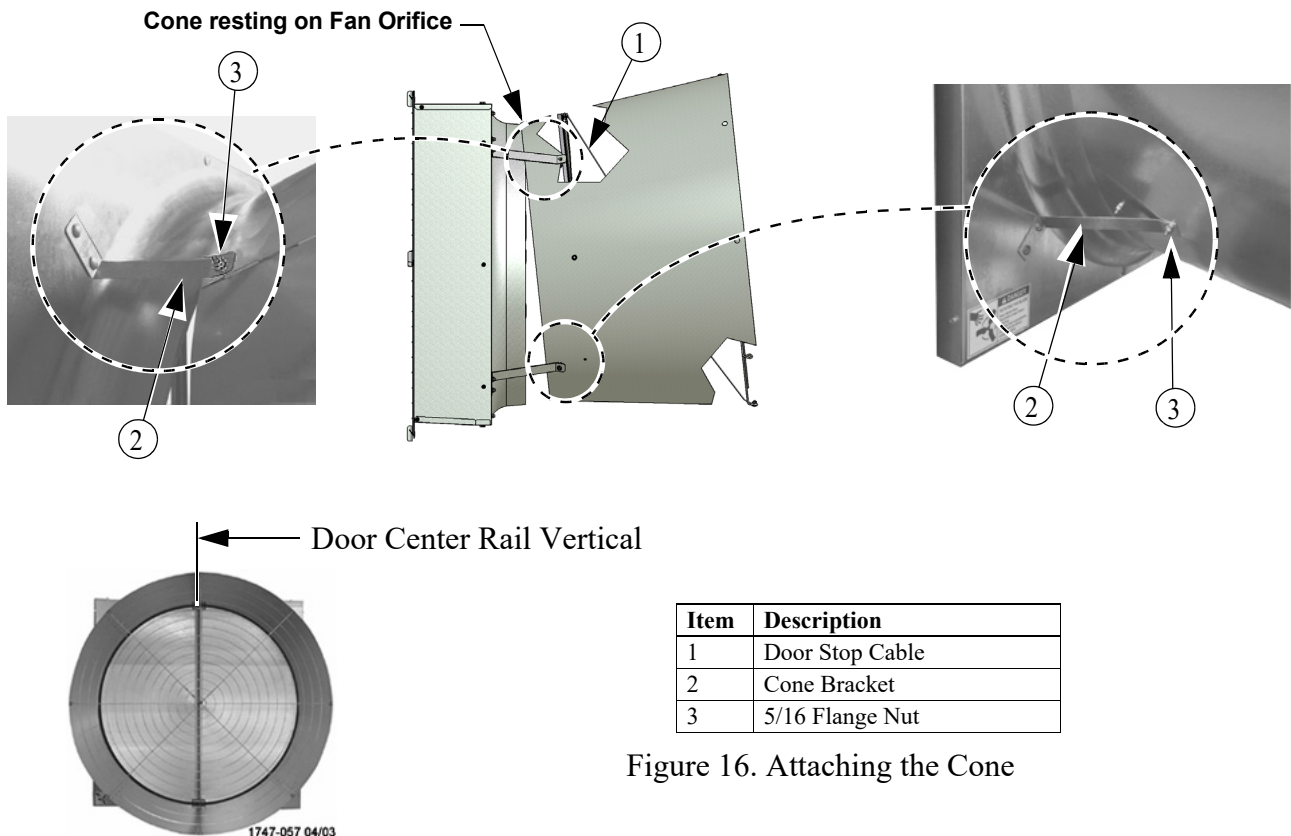

Item	Description
1	Door Stop Cable
2	Cone Bracket
3	5/16 Flange Nut

Figure 16. Attaching the Cone

Door Spring Assembly

Step 1: On the Door Assembly, at the middle of the Door Center Brace, attach the Spring Mounting Bracket (**Included in the Parts Package**)

Step 2: Hook the rounded ends of the Door Springs onto the Spring Mounting Bracket. Stretch the Door Springs out and hook them in the 3/32" holes in the Doors.

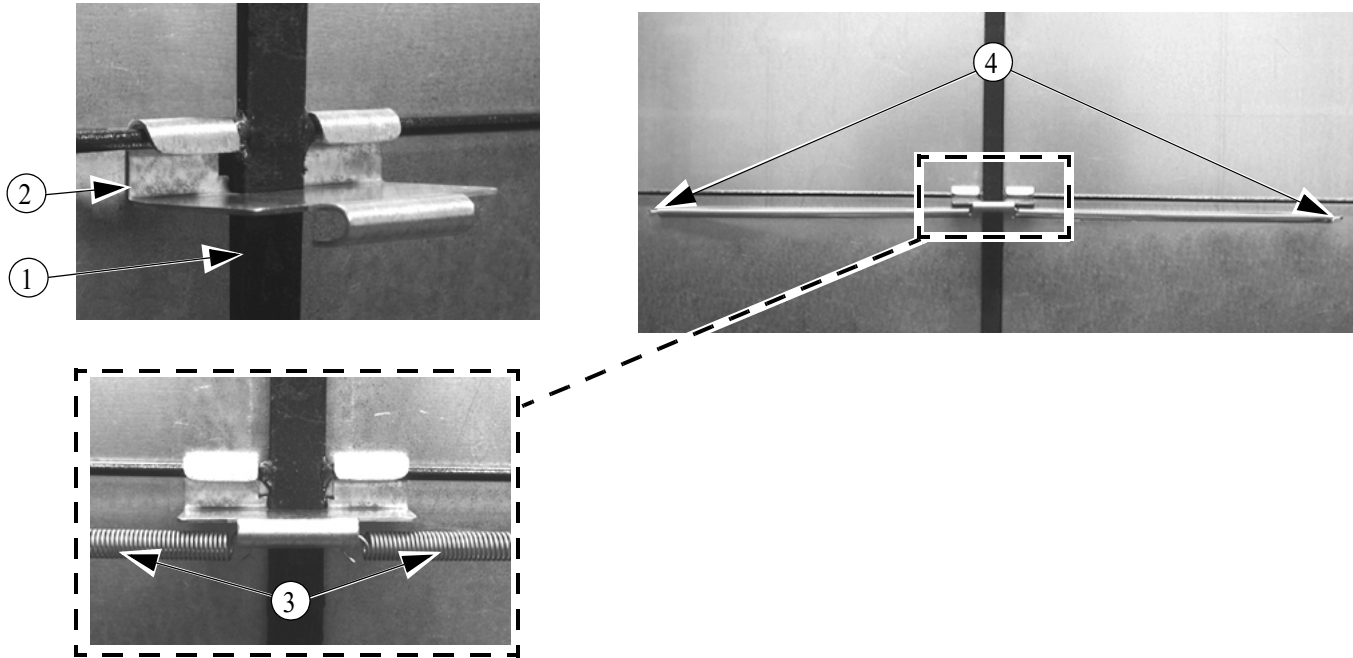

Item	Description
1	Door Center Brace
2	Spring Mounting Bracket
3	Door Spring
4	3/32" hole in Door

Figure 17. Attaching the Spring Mounting

Cone Drain Tabs

The Fan Cone is designed with a C-Shaped Drain Tab located at the back of the Bottom Cone Panel. Use a screw driver to push the Drain Tab out as shown in **Figure 18** below.

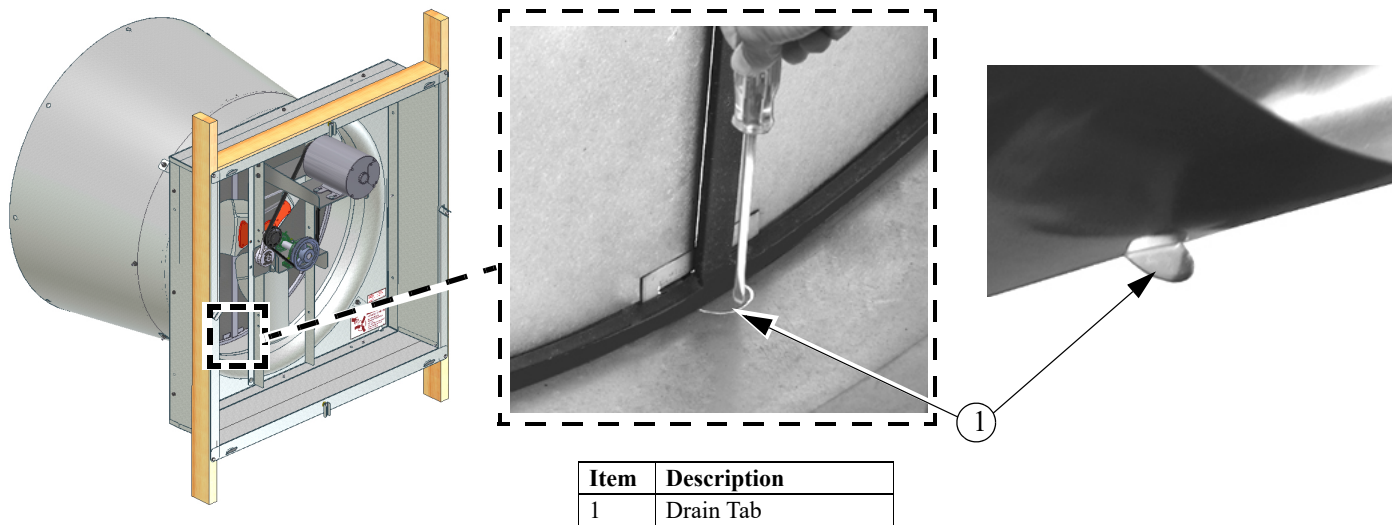
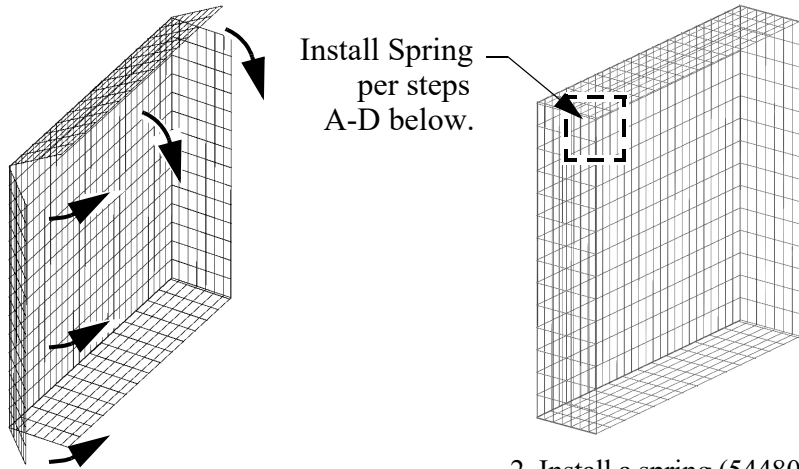

Figure 18. Cone Drain Tab

Assembling the Screen



1. Fold the Screen Sides as shown.

Install Spring per steps A-D below.

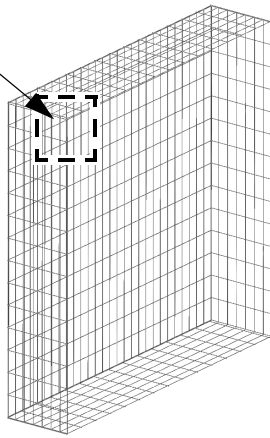

2. Install a spring (54480) in the **upper left corner** following steps A through D below. After Step D is complete go to step 3.

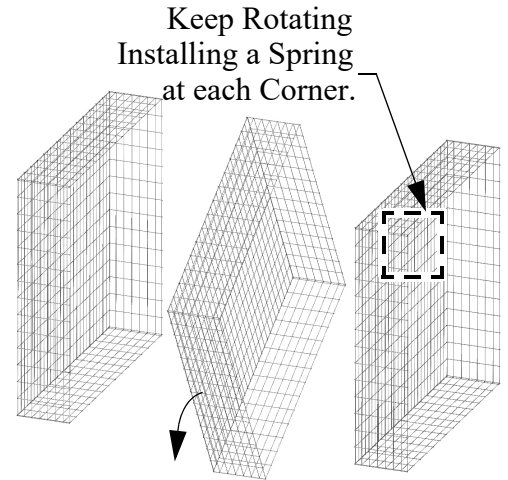

3. Rotate the Screen in the direction shown installing a Spring at a second corner. **Repeat for remaining Corners.**



A) Slide a Spring (54480) over both Screen Panel Wires exactly as shown.

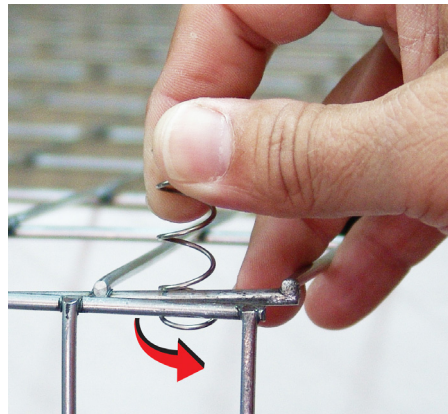

B) Rotate the Spring Counter-Clockwise until the end of the Spring snaps over the Side Panel Wire.

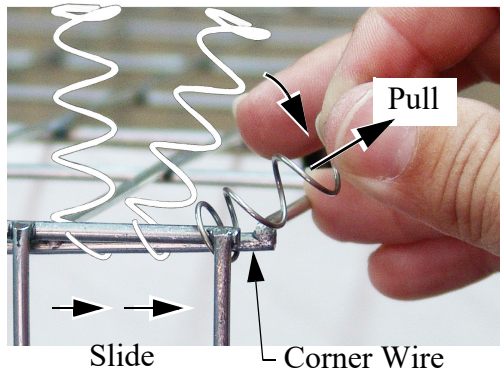
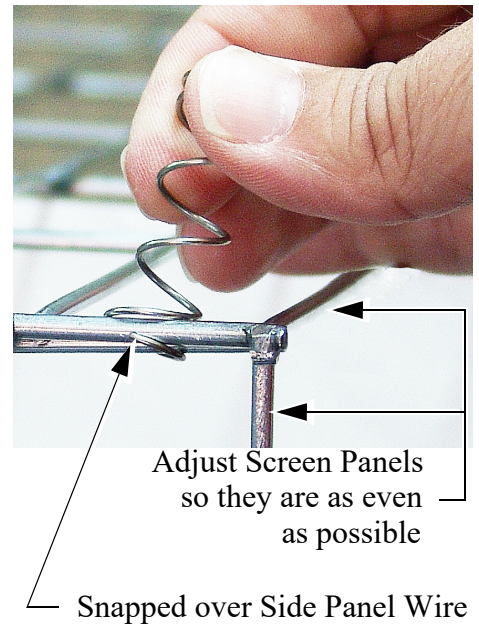

C) Slide and Pull Spring over Corner Panel Wire.

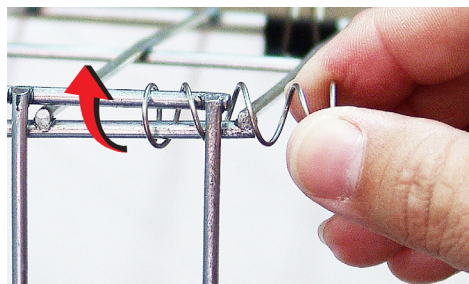

D) Twist Spring Clockwise until it is passed the outside wire and snapped firmly in place.

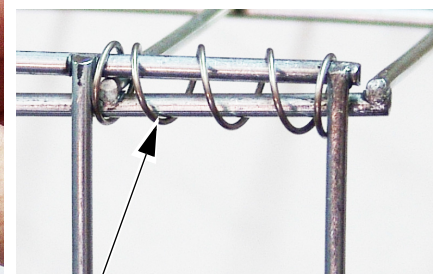

Spring snapped firmly between wires.

Figure 19. Assembling the Screen

Installing the Screen

Step 1: Hang the Screen (**Item 1**) on the four Screen Clips (**Item 2**) and position so that Screen Wire is captured between 1/8" tall Tabs and Screen Retainers (**Item 3**).

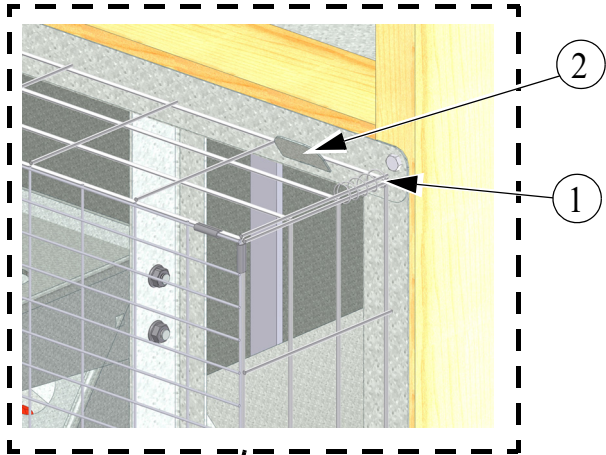

Step 2: Rotate the four Screen Retainers to capture the Screen.

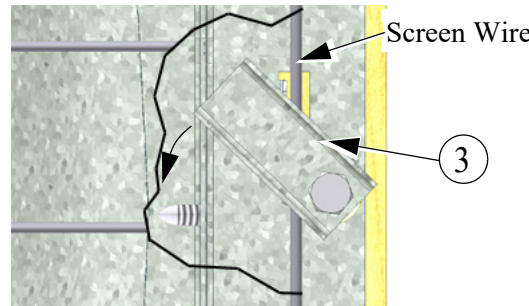
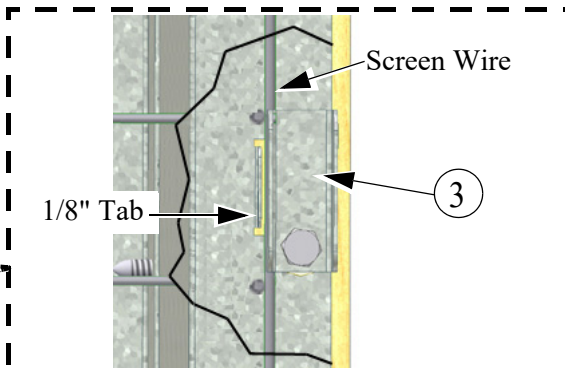
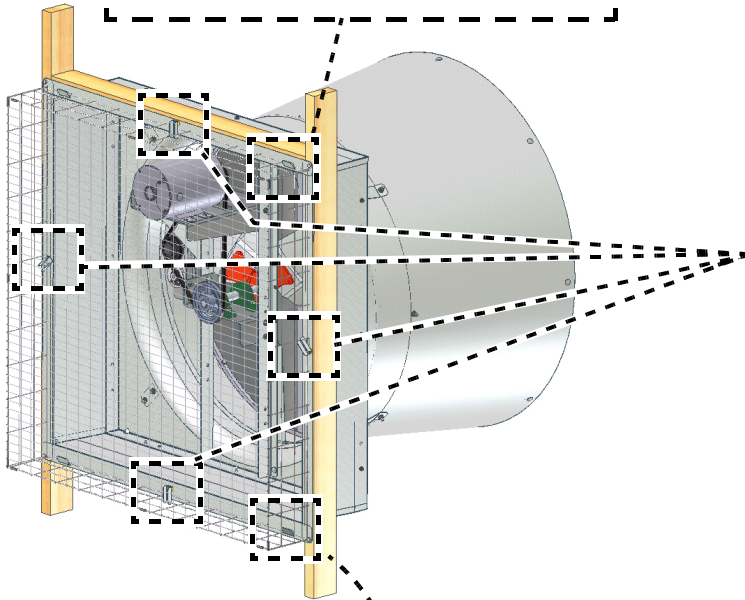

Front of Screen Cut away for Clarity

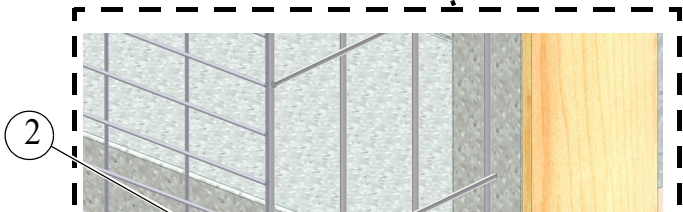

Wiring

1. Check that the electrical power being supplied to the Fan matches the electrical Specifications on the Fan and Motor Decals.
2. Remove the Motor Access Cover.
3. Install an electrical disconnect within reach of each Fan installed.
4. Connect the cord to the motor according to the wiring diagram on the motor. Verify that the motor is connected for counter clockwise rotation (viewing the back of the motor, opposite the shaft end.)
5. Follow local, state, and national electrical codes for wiring. Cut out one section of the Screen to route the cord out of the Fan: This will allow for the Screen to be removed without interfering with the Cord. (See **Figure 21**). Attach the cord to the Wall using a Lag Screw and Cord Clip. Allow enough slack in the cord to form a "drip loop" for moisture to fall away from the cord and not into the motor

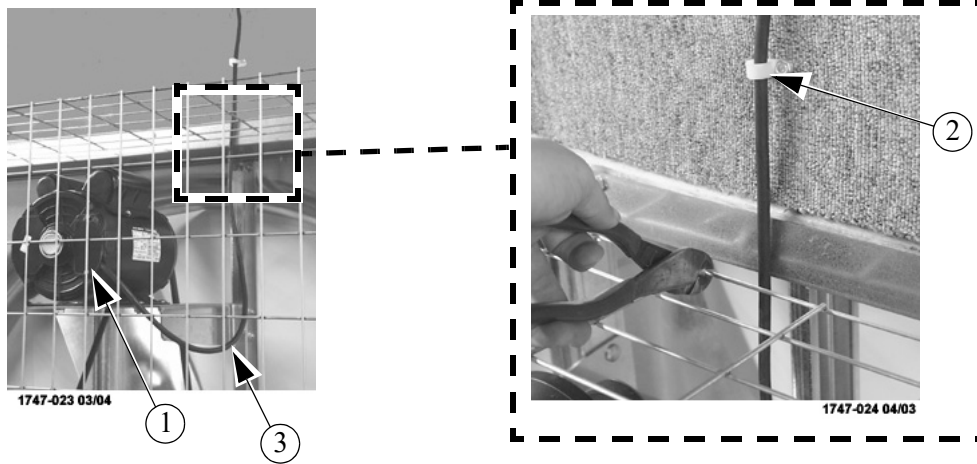

Item	Description
1	Motor Access Cover
2	Cord Clip
3	Drip Loop

Figure 21. Cut out Screen for Motor Wiring

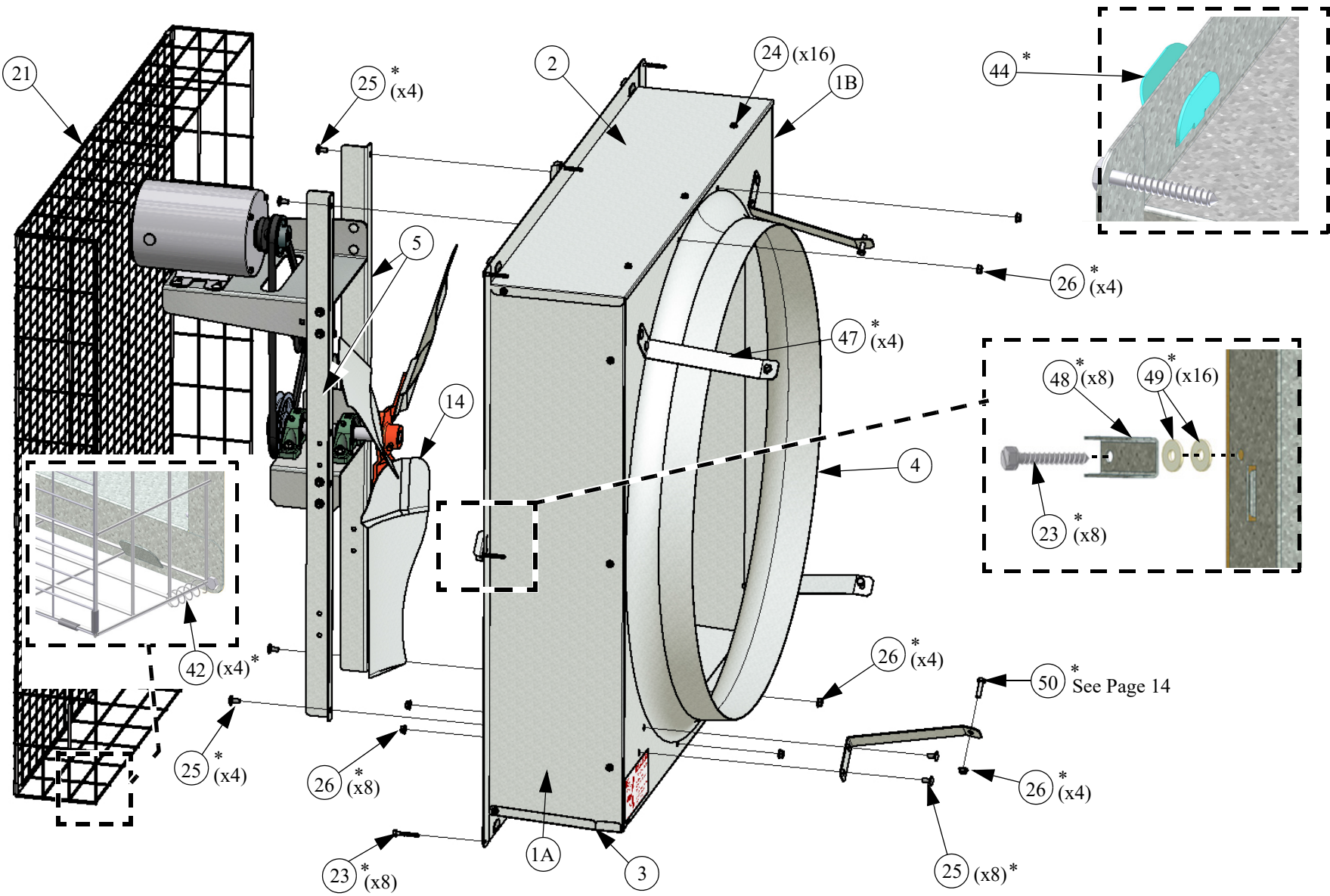

Itemized Parts

Part Numbers

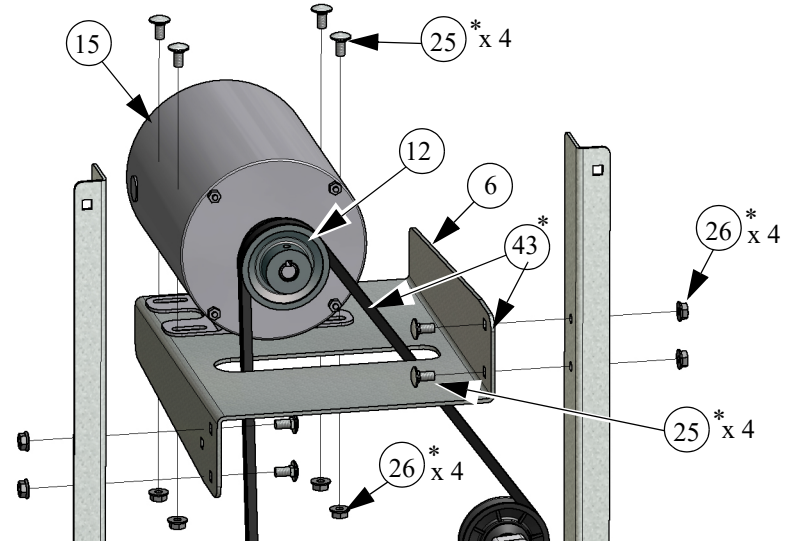
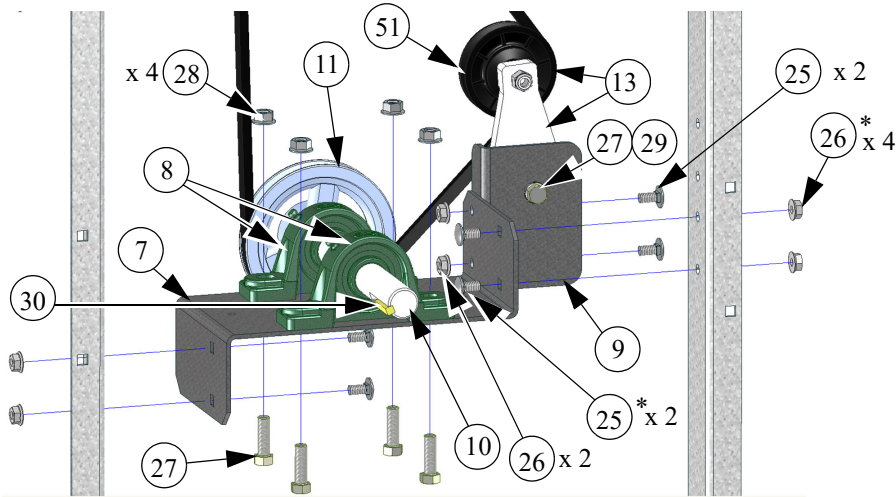

36" Fan Part Numbers

Item	Qty.	Part Description	Part No.
1A	1	R.H. Side Housing Panel	50278-2
1B	1	L.H. Side Housing Panel	50278-1
2	1	Top Housing Panel	50276
3	1	Bottom Housing Panel	50277
4	1	36" Fan Shroud	5538
5	2	36" Fan Post	53097
6	1	Idler Drive Motor Support	53099
7	1	Idler Drive Bearing Support	48395
8	2	1" Cast Pillow Block Bearing	50553
9	1	Tensioner Support	48394
10	1	1" Dia. (9.849") Fan Shaft	53098
11	1	AK51 x 1.00 Bore Sheave	42338
12	1	AK30 3" O.D. x 5/8 Bore	8773
13	1	3.5" Tensioner Assembly	48429
14	1	36" Fan Blade	56178
15	1	5HP 3Ph Motor	38566
17	4	36" HYFLO Cone Panel	50285
18	2	Danger Decal	2527-50
19	1	Fan Description Decal	39002-XXX

Item	Qty.	Part Description	Part No.
21	1	44" Wire Screen	53103
23*	9	1/4-10 x 1.75" Lag Screw	51039
24*	16	1/4-14 x 1/2" HXWH Screw	48439
25*	34	5/16-18 x .625 Carriage Bolt	8282
26*	44	5/16-18 HX Ser. Flange Nut	8490
27	5	3/8-16 x 1.25 HHCP Bolt	39-20414
28	4	3/8-16 Ser. Flange Nut	39-45692
29	1	3/8 Lock Washer	5747
30	2	1/4" Sq. x 1.13 Key	2419-2
31	1	Hardware Package	53104
32	AR	Anti-Seize	RML092
34	2	Wire Tie	RML120
42	1	Screen Spring (Package of 4)	54480-4
43*	1	48.2" (AX46) V-Belt	4409
44*	4	HYFLO Screen Clip .06 Offset	50409
47*	4	Cone Support Bracket	49445
48*	4	Screen Clip	36729
49*	8	.260 x .69 x .060 Nylon Washer	4856
50*	6	5/16-18 x 1.25 HH5 Bolt	2150
51	-	Idler Pulley (Repair Part)	50879

Itemized Parts (Continued).....

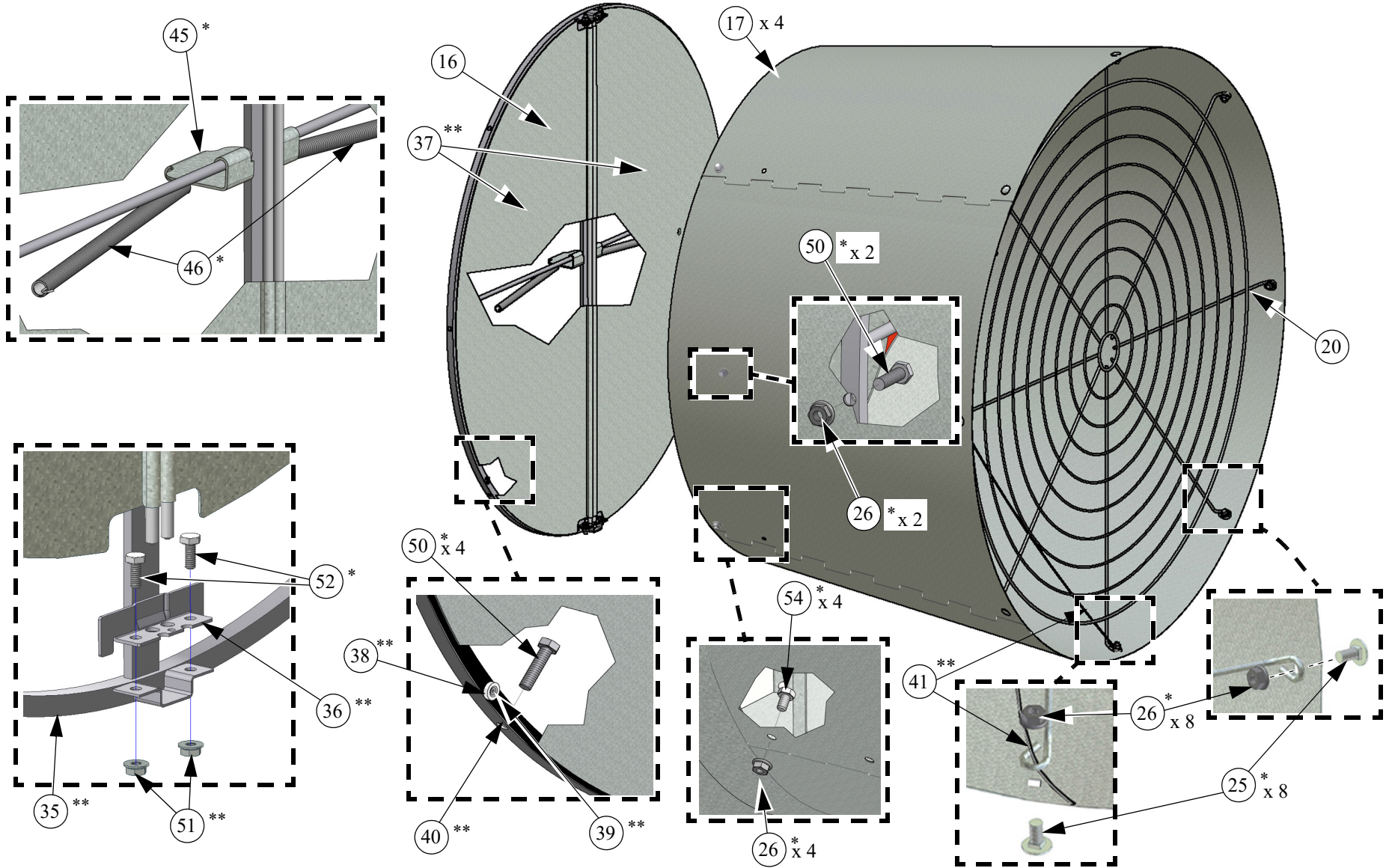

Part Numbers (Continued)

Item	Qty.	Part Description	Part No.
16	1	36" HYFLO Door Assembly	50311
20	1	36" Cone Grill	37629
25*	34	5/16-18 x .625 Carriage Bolt	8282
26*	44	5/16-18 HX Ser. Flange Nut	8490
35*	1	36" HYFLO Fan Frame	50293
36*	2	Fan Door Pivot Plate	49598
37**	2	36" HYFLO Fan Door	50292
38**	2	.125 x Ø.50 Magnet	48427
39**	2	1/8 x .40 Pop Rivet	48936
40**	10'	1/2" Foam Tape	48425
41**	1	46.75" Cable Assembly	50618-3
45*	1	Door Spring Support	49450
46*	2	.055 x .50 x 11" Spring	49629
51**	4	1/4-20 Serrated Flange Nut	46460
50*	6	5/16-18 x 1.25 HH5 Bolt	2150
52**	6	1/4-20 x 5/8" Bolt	2152
53*	1	Nylon Clip (Not Shown) Used to secure Cord to the Wall.	565
54*	4	5/16-18 x .50 HH5 Bolt	1839
(* Included in Parts Package 53104) (** Included in Door Assembly 50311)			

Maintenance

IMPORTANT! Disconnect Power Prior To Maintaining Or Cleaning The Fan. The fan may start automatically causing serious injury or death.

- Service and repair of fans should be done only by a qualified technician.
- Minimize contact of moisture or corrosive chemicals to the surfaces of the fan components to maximize fan life.
- After washing fans, operate fans long enough to remove moisture from all fan surfaces.
- Keep the fan clean for maximum life and best performance. **Do Not spray water on the Fan Shaft Bearings, the Belt Tensioner, or the Motor.**
- Periodically check the V-Belt and replace if necessary. A worn Belt will cause a substantial drop in Fan performance or it can break and cause Fan failure. If a Belt rides below the Sheave edge, replace the belt. (See Figure 22 below)

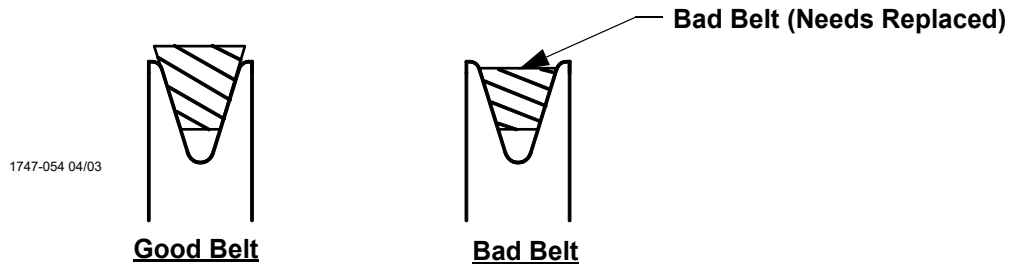

Figure 22. Belt Condition

- Check Belt Tension. The Belt should be tensioned just tight enough to minimize Belt slippage. Over tensioning the belt will cause premature Belt and Bearing wear. With a new Belt the Idler Sheave indicator mark should line up with the third notch in the Tensioner Housing (See Figure 23).

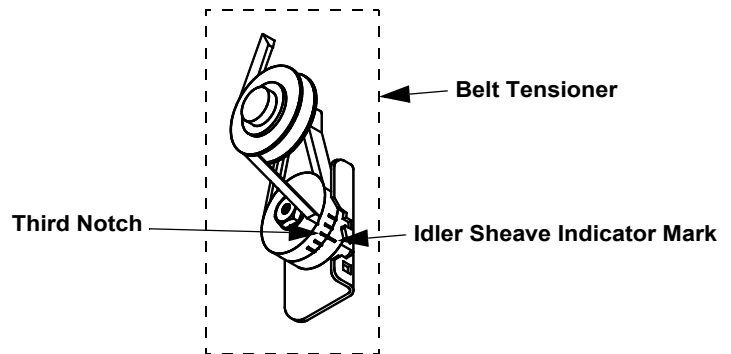

Figure 23. Idler Sheave Indicator Mark

- Keep Shutters, Blades, and Housing clear of obstacles for best air performance.
- Check Sheaves for wear. Replace if a Sheave groove is worn. (See Figure 24)

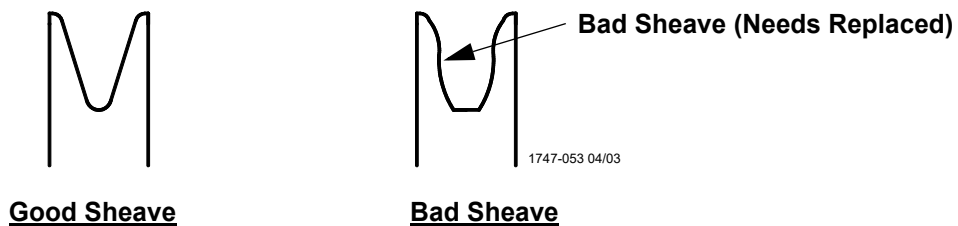
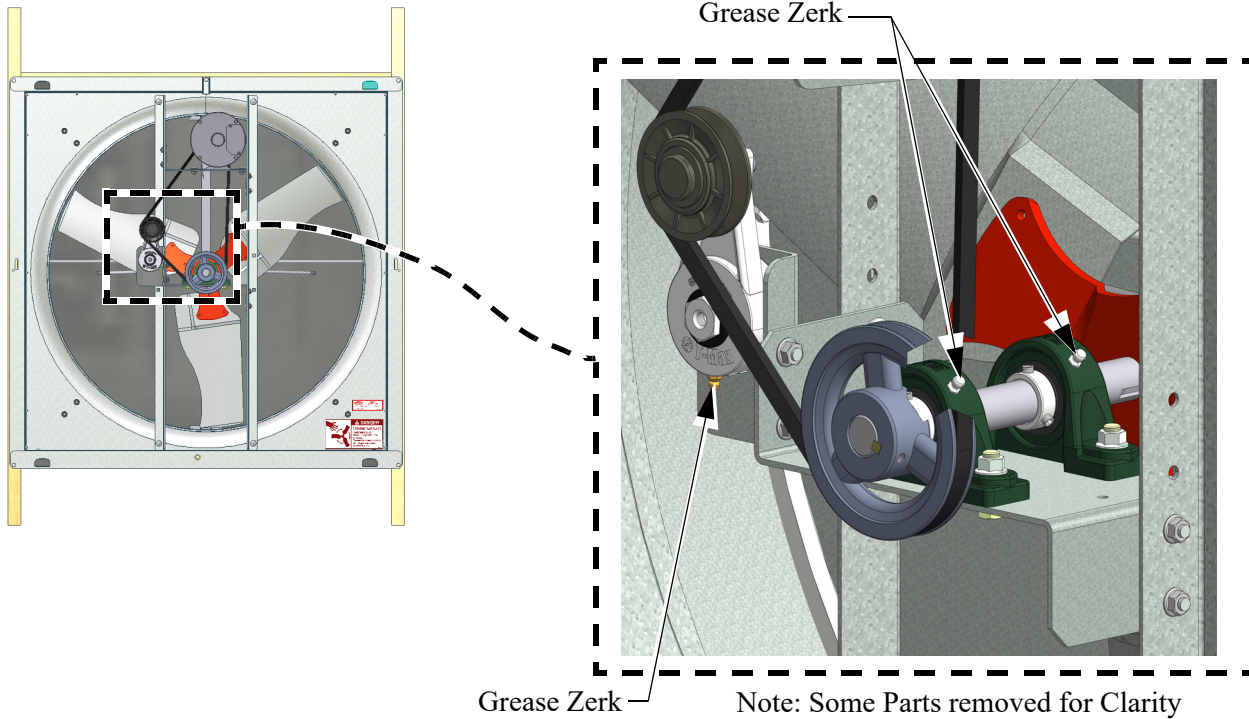

Figure 24. Sheave Condition

Fan Bearing and Belt Tensioner Lubrication

- Grease zerks are provided for lubrication on the fan shaft bearings and the belt tensioner.
- Lubricate the fan every 2-6 months or whenever these components get wet.
- Disconnect power to the fan before lubricating.
- Clean the zerk before lubricating to prevent contamination from entering the bearing.
- Use a high quality lithium based, NLGI #2, grease such as Shell Gadus S2 V100 2. Do not use incompatible greases containing aluminum, barium, calcium, bentonite clay or polyurea thickeners.
- Slowly rotate the fan shaft by hand while slowly applying the grease. Rapidly applying grease to a stationary bearing can damage the bearing seals.
- Apply about .10 oz (2.8 g, 3.1 cc) of grease at a time or until a slight amount of grease can be seen purging from the seal.





**Made to work.
Built to last.**

Note: The original, authoritative version of this manual is the [English] version produced by CTB, Inc. or any of its subsidiaries or divisions, (hereafter collectively referred to as "CTB"). Subsequent changes to any manual made by any third party have not been reviewed nor authenticated by CTB. Such changes may include, but are not limited to, translation into languages other than [English], and additions to or deletions from the original content. CTB disclaims responsibility for any and all damages, injuries, warranty claims and/or any other claims associated with such changes, inasmuch as such changes result in content that is different from the authoritative CTB-published [English] version of the manual. For current product installation and operation information, please contact the customer service and/or technical service departments of the appropriate CTB subsidiary or division. Should you observe any questionable content in any manual, please notify CTB immediately in writing to: CTB Legal Department, P.O. Box 2000, Milford, IN 46542-2000 USA.

Revisions to this Manual

Page No.	Description of Change	ECO
17	Added 50879 Pulley (Repair Part)	34048

**For additional parts and information, contact your nearest Chore-Time distributor or representative.
Find your nearest distributor at: www.choretime.com/contacts**

Chore-Time Group, A division of CTB, Inc.
PO Box 2000
Milford, Indiana 46542-2000 USA
Phone (574) 658-4101 Fax (877) 730-8825
Email: choretime@choretime.com
Internet: www.choretime.com