

Part Number 41920-18 Standard, and 44458-18 Chain Drive Version

Linear Lift™ 800 Assembly

Installation & Operator's Instruction Manual



1083-10 1/99

Chore-Time Warranty

Chore-Time Group, a division of CTB, Inc. (“Chore-Time”) warrants new CHORE-TIME Linear Lifts™ and Linear Lift™ Components manufactured by Chore-Time to be free from defects in material or workmanship under normal usage and conditions, for One (1) year from the date of installation by the original purchaser (“Warranty”). If such a defect is determined by Chore-Time to exist within the applicable period, Chore-Time will, at its option, (a) repair the Product or Component Part free of charge, F.O.B. the factory of manufacture or (b) replace the Product or Component Part free of charge, F.O.B. the factory of manufacture. This Warranty is not transferable, and applies only to the original purchaser of the Product.

CONDITIONS AND LIMITATIONS

THIS WARRANTY CONSTITUTES CHORE-TIME’S ENTIRE AND SOLE WARRANTY AND CHORE-TIME EXPRESSLY DISCLAIMS ANY AND ALL OTHER WARRANTIES, INCLUDING, BUT NOT LIMITED TO, EXPRESS AND IMPLIED WARRANTIES, INCLUDING, WITHOUT LIMITATION, WARRANTIES AS TO MERCHANTABILITY OR FITNESS FOR PARTICULAR PURPOSES. CHORE-TIME shall not be liable for any direct, indirect, incidental, consequential or special damages which any purchaser may suffer or claim to suffer as a result of any defect in the Product. Consequential or Special Damages as used herein include, but are not limited to, lost or damaged products or goods, costs of transportation, lost sales, lost orders, lost income, increased overhead, labor and incidental costs, and operational inefficiencies. *Some jurisdictions prohibit limitations on implied warranties and/or the exclusion or limitation of such damages, so these limitations and exclusions may not apply to you. This warranty gives the original purchaser specific legal rights. You may also have other rights based upon your specific jurisdiction.*

Compliance with federal, state and local rules which apply to the location, installation and use of the Product are the responsibility of the original purchaser, and CHORE-TIME shall not be liable for any damages which may result from non-compliance with such rules.

The following circumstances shall render this Warranty void:

- Modifications made to the Product not specifically delineated in the Product manual.
- Product not installed and/or operated in accordance with the instructions published by the CHORE-TIME.
- All components of the Product are not original equipment supplied by CHORE-TIME.
- Product was not purchased from and/or installed by a CHORE-TIME authorized distributor or certified representative.
- Product experienced malfunction or failure resulting from misuse, abuse, mismanagement, negligence, alteration, accident, or lack of proper maintenance, or from lightning strikes, electrical power surges or interruption of electricity.
- Product experienced corrosion, material deterioration and/or equipment malfunction caused by or consistent with the application of chemicals, minerals, sediments or other foreign elements.
- Product was used for any purpose other than for the care of poultry and livestock.

The Warranty and Extended Warranty may only be modified in writing by an officer of CHORE-TIME. CHORE-TIME shall have no obligation or responsibility for any representations or warranties made by or on behalf of any distributor, dealer, agent or certified representative.

Effective: **April, 2014**

Contents

Topic	Page	User
Chore-Time Warranty	2	C,D
Support Information	4	
General	4	C,D,I
Distributor and Installer Information	4	
About This Manual	5	C,I
Safety Information	5	C,I
Safety–Alert Symbol	5	
Understanding Signal Words	5	
Follow Safety Instructions	6	
Decal Descriptions	6	
DANGER: Moving Auger	6	
DANGER: Electrical Hazard	6	
Available Sizes and Speed of Operation	7	
Cable/Pulley Combinations	7	
Linear Lift™ 800 41920-18 Side Wall Installation	8	
Linear Lift™ 800 44458-18 (Chain Drive) Side Wall Installation	9	
Linear Lift™ 800 Installation	10	C,I
Grease Recommendation	10	
Wiring Diagram	12	I
Optional Suspension Parts Listing	13	C,D,I
Linear Lift™ 800 Parts List	14	C,D,I
Parts Listing and Identification	15	C,D,I

General

Support Information

The Chore-Time Linear Lift™ 800 Assembly is designed to open inlet doors. Using this equipment for any other purpose or in a way not within the operating recommendations specified in this manual will void the warranty and may cause personal injury.

This manual is designed to provide comprehensive planning, installation, safety, operation, and parts listing information. The Table of Contents provides a convenient overview of the information in this manual. The Table of Contents also specifies which pages contain information for the sales personnel, installer, and consumer (end user).

Distributor and Installer Information

Please fill in the following information about your Product.
Keep this manual in a clean, dry place for future reference.

Distributor's Name _____

Distributor's Address _____

Distributor's Phone _____ **Date of Purchase** _____

Installer's Name _____

Installer's Address _____

Installer's Phone _____ **Date of Installation** _____

System Specifications _____

About This Manual

The intent of this manual is to help you in two ways. One is to follow step-by-step in the order of assembly of your product. The other way is for easy reference if you have questions in a particular area.

Important ! Read **ALL** instructions carefully before starting construction.

Important ! Pay particular attention to all **SAFETY** information.

- *Metric measurements are shown in millimeters and in brackets, unless otherwise specified. “ ” equals inches and “ ’ ” equals feet in English measurements.*

Examples:

1" [25.4]

4' [1 219]

- Optional equipment contains necessary instructions for assembly or operation.
- Major changes from the last printing will be listed on the back cover.
- This Planning Symbol is used in areas where planning needs to take place before construction continues.
- Very small numbers near an illustration (*i.e.*, 1257-48) are identification of the graphic, not a part number.



Safety Information

Caution, Warning and Danger Decals have been placed on the equipment to warn of potentially dangerous situations. Care should be taken to keep this information intact and easy to read at all times. Replace missing or damaged safety decals immediately.

Using the equipment for purposes other than specified in this manual may cause personal injury and/or damage to the equipment.



Safety–Alert Symbol

This is a safety–alert symbol. When you see this symbol on your equipment, be alert to the potential for personal injury. This equipment is designed to be installed and operated as safely as possible...however, hazards do exist.

Understanding Signal Words

Signal words are used in conjunction with the safety–alert symbol to identify the severity of the warning.



DANGER indicates an imminently hazardous situation which, if not avoided, **WILL** result in death or serious injury.



WARNING indicates a potentially hazardous situation which, if not avoided, **COULD** result in death or serious injury.



CAUTION indicates a hazardous situation which, if not avoided, **MAY** result in minor or moderate injury.

Safety Information

Follow Safety Instructions

Carefully read all safety messages in this manual and on your equipment safety signs. Follow recommended precautions and safe operating practices.

Keep safety signs in good condition. Replace missing or damaged safety signs.

Decal Descriptions

DANGER: Rotating Parts

Severe personal injury will result, if the electrical power is not disconnected, prior to servicing the equipment.

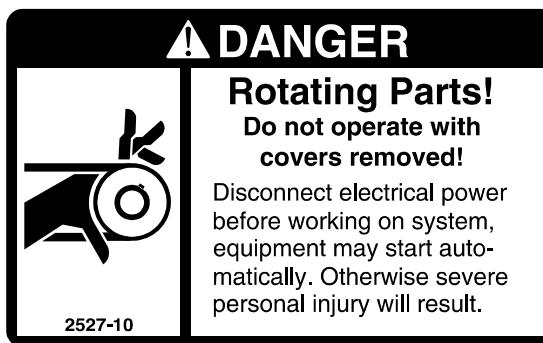

DANGER: Electrical Hazard

Disconnect electrical power before inspecting or servicing equipment unless maintenance instructions specifically state otherwise.

Ground all electrical equipment for safety.

All electrical wiring must be done by a qualified electrician in accordance with local and national electric codes.

Ground all non-current carrying metal parts to guard against electrical shock.

With the exception of motor overload protection, electrical disconnects and over current protection are not supplied with the equipment.

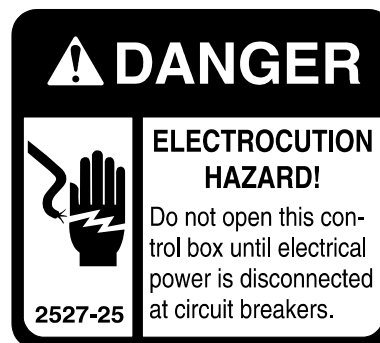

Available Sizes and Speed of Operation

- The Linear Lift™ 800 has a total stroke of 18".
- The lifting speed is 12" per minute.
- Total Weight Capacity of the Lift is 800 lbs.

Cable/Pulley Combinations

Same Speed (Ratio 1:1)

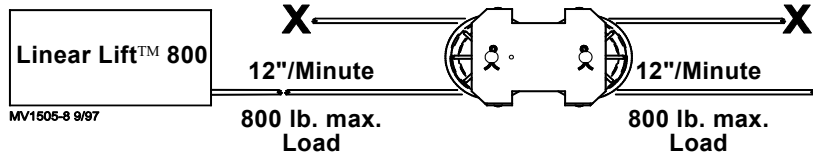

Speed Up (Ratio 1:2)

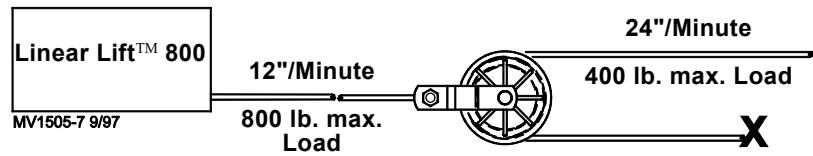

Slow Down (Ratio 2:1) (Standard)

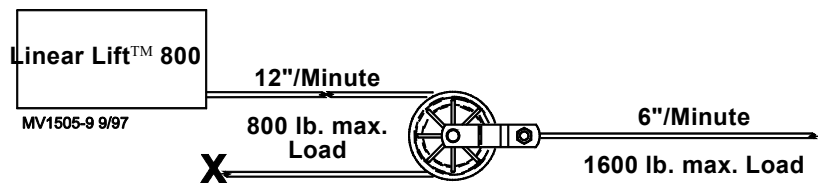
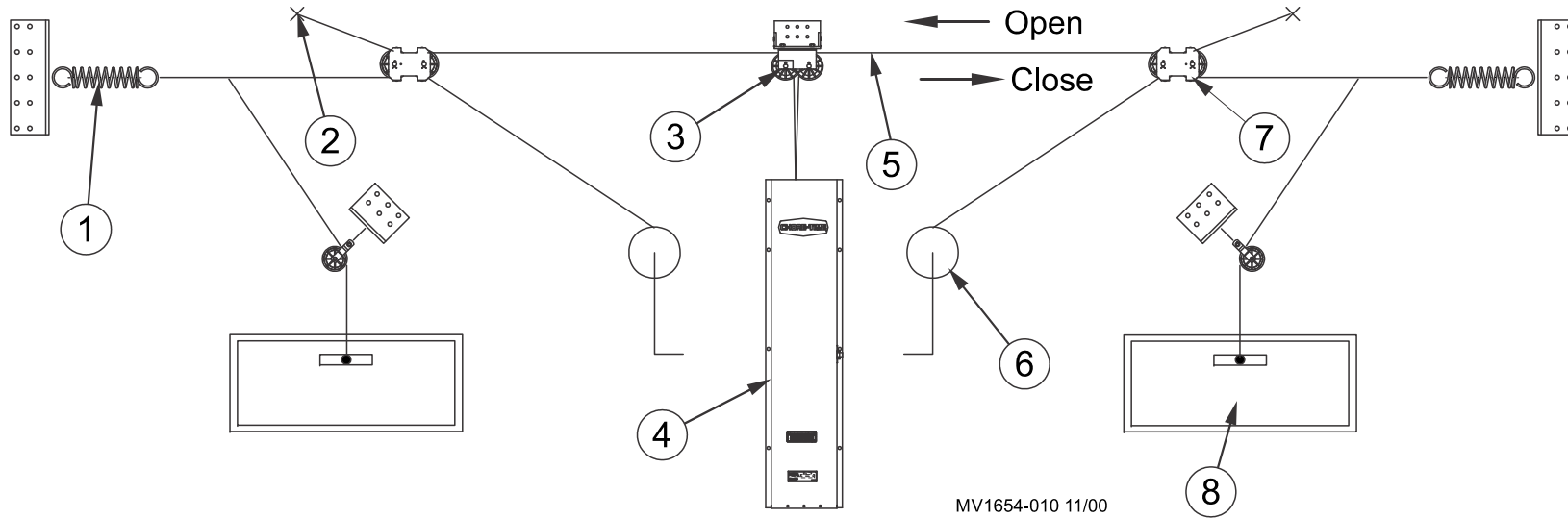

Figure 1. Cable Ratio Diagram (side view).

Linear Lift™ 800 (41920-18) Side Wall Installation With Spring Tension Closing Inlet Doors



MV1654-010 11/00

Linear Lift™ 800		
Item	Description	Part Number
1	Inlet Spring (Close Doors)	41143
2	Tie Down	
3	Double Pulley Assembly	43272
4	Linear Lift™ 800 (Open Doors)	41920-18
5	Curtain Cable	
6	Hand Winch Winch Mounting Assembly	1212 1193
7	Double Pulley Assembly	27772
8	Inlet Door	

Figure 4. Linear Lift™ 800 Side Wall Installation with a 1:1 double-back cable arrangement

Linear Lift™ 800 (44458-18 Chain Drive) Installation with Spring Tension Closing Inlet Doors

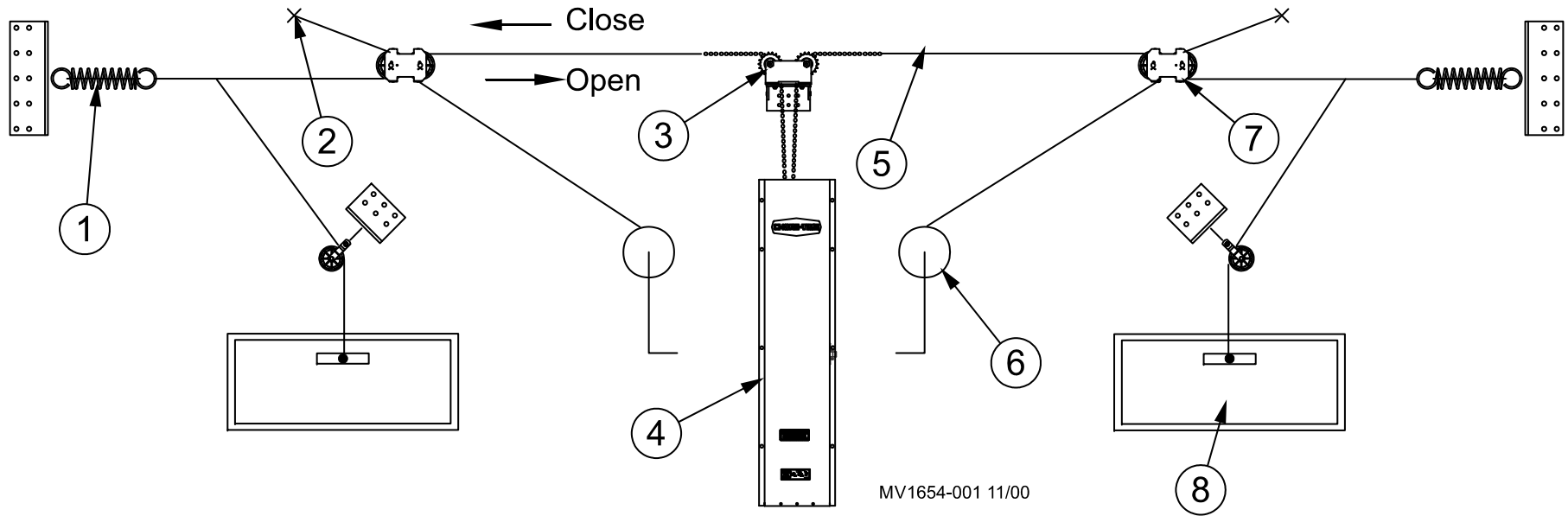

MV1654-001 11/00

(Chain Drive) Linear Lift™ 800		
Item	Description	Part Number
1	Inlet Spring (Close Doors)	41143
2	Tie Down	
3	Double Pulley Assembly	44520*
4	Chain Drive Linear Lift™ 800 (Open Doors)	44458-18
5	Curtain Cable	
6	Hand Winch	1212
	Winch Mounting Assembly	1193
7	Double Pulley Assembly	27772
8	Inlet Door	
*Standard with Chain Drive Linear Lift™ 800		

Figure 5. Side Wall (Chain Drive) Linear Lift™ 800 with a 1:1 double-back cable arrangement

Linear Lift™ 800 Installation

The Linear Lift™ 800 may be mounted to the wall or ceiling, using (8) 3/8" Lag Screws (included in the Hardware Package). **See Figure 8.**

1. Route the cable as required to the main curtain or baffle board cable.
2. Mount the Linear Lift™ 800 to the wall or ceiling using the hardware provided. **See note below.**

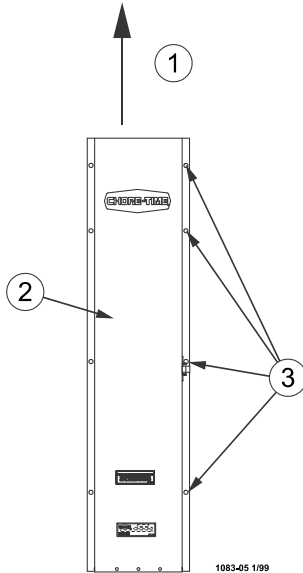

Item	Description
1	Cable Routing
2	Linear Lift™ 800
3	Mounting Hole Locations

Figure 8. Linear Lift™ 800 Installation (vertical wall view)

Grease Recommendation

The LINEAR-LIFT™ is fully greased at the factory. However, for maximum life, Chore-Time strongly recommends greasing the Linear Lift™ 800 at each grease fitting monthly. For best results apply grease through grease fitting while Linear Lift™ 800 is in operation to put an even coating of grease over the entire length of the Threaded Shaft.

Recommended Grease: Sunoco Construction Grease or Mobile CMP Grease (available through Grainger) or similar water-resistant with moly, extreme pressure (E.P.) grease. **See Figure 9.**

IMPORTANT: Grease monthly for maximum life.

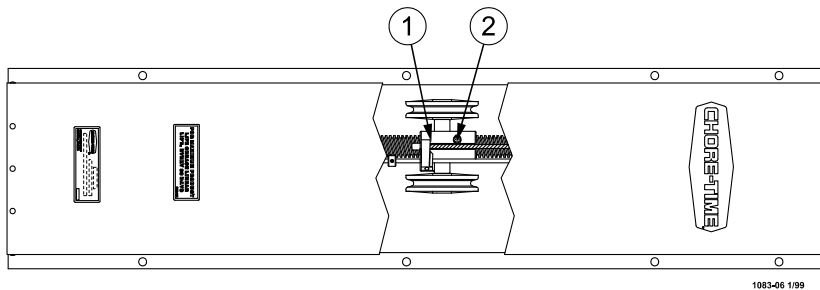

Item	Description
1	Machined Nut
2	Grease Fitting

Figure 9. Linear Lift™ 800 Critical Grease Fitting Locations (horizontal wall mount view)

Linear Lift™ 800 Switch Adjustment

The Linear Lift™ 800 has adjustable stops (Set Collars) that may be moved to accommodate a variety of inlet opening lengths.

A 1/8" Allen wrench is required to loosen the set screw on the Set Collar (see **Item 2 below**). Slide the Set Collar(s) on the Switch Rod allow for the maximum inlet opening travel (see **Item 4 below**).

Figure 10 shows the maximum travel settings (at a 1:1 ratio) of the Linear Lift™ 800s available.

Figure 10. Linear Lift™ 800 Adjustment (side view)

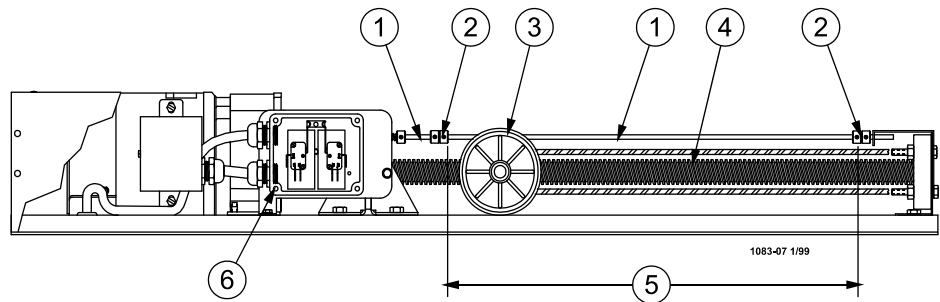

Item	Description	Part No.
1	Switch Rod	41915-1
2	Adjustable Stops (set collar)	41857
3	Nut Assembly	41957
4	Threaded Rod	35945-6
5	Maximum Travel (18")	-
6	Switch Assembly	41916

Wiring Diagram

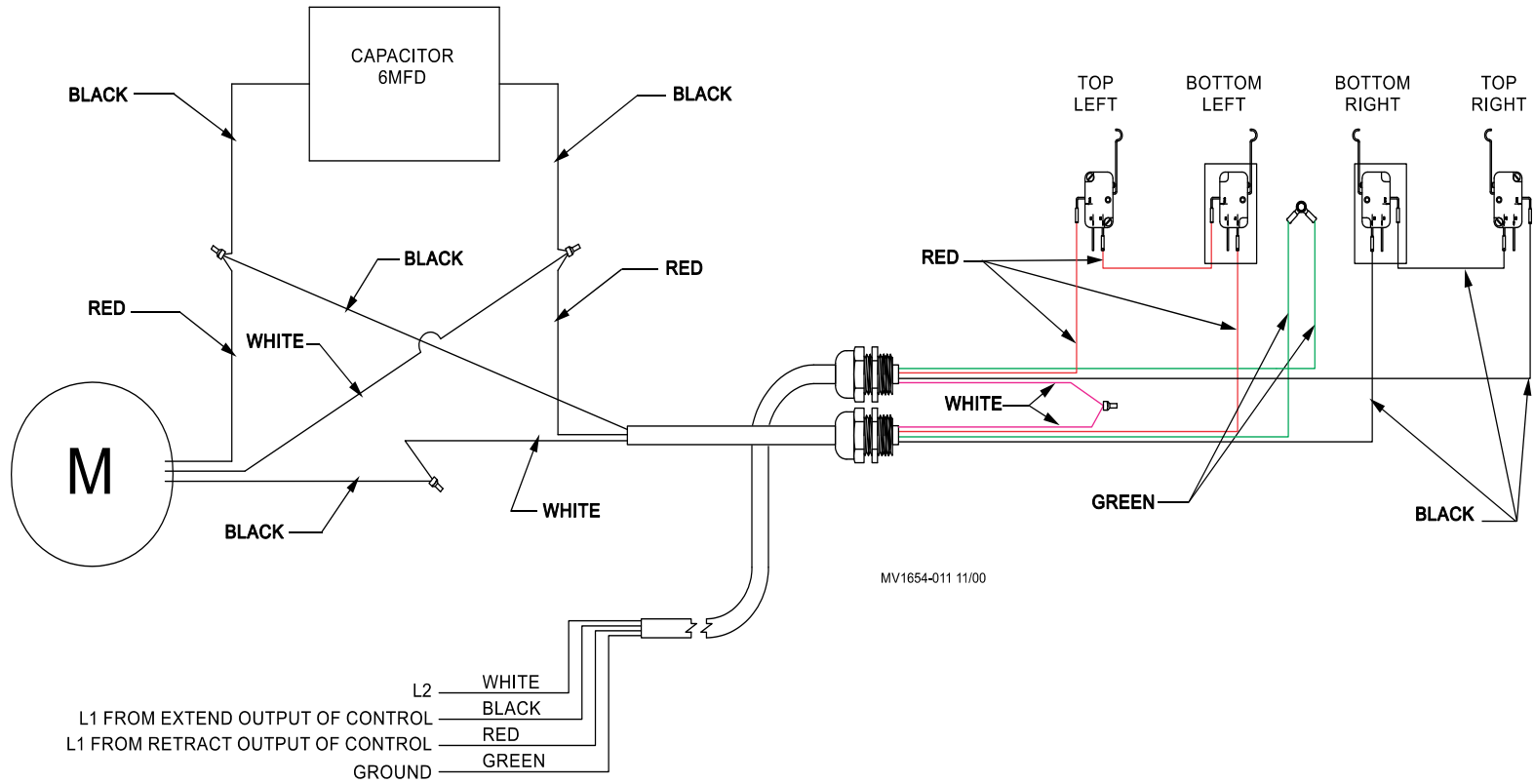

MV1654-011 11/00

Optional Suspension Parts Listing

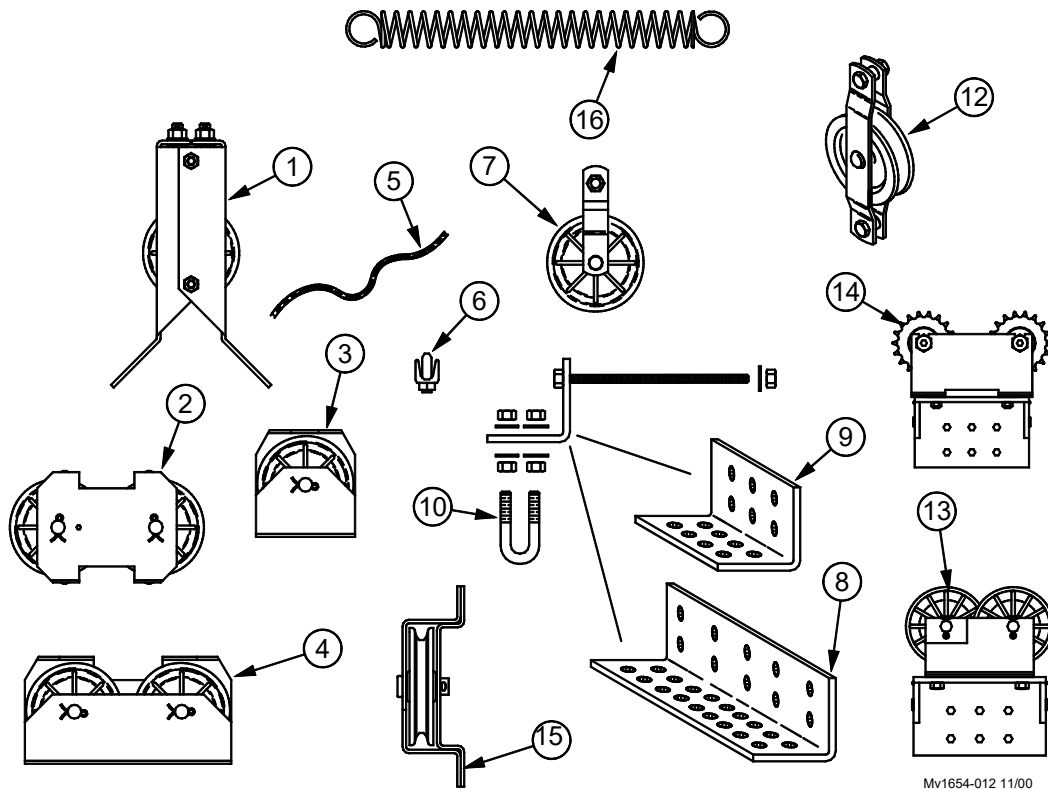

MV1654-012 11/00

Item	Description	Part No.
1	Corner Pulley Assembly	35597
2	Double Pulley Assembly	27772
3	Pulley Kit	27301
4	Center Pulley Assembly	27302
5	3/16" Cable (150')—7/19 3/32" Cable—galvanized	13976 4973
6	3/16" Cable Clamp	732
7	Pulley Assembly	2500
8	Double Pulley Mounting Brkt.	35404
9	Single Pulley Mounting Brkt.	35405
10	3/16-18x7" U Bolt with Nuts	35602
11	5/16-18x7" Bolt	4412-20
12	Double Eye Pulley	2501
13	Double Pulley Assembly	43272
14	Double Sprocket Assembly	44520
15	Pulley Assembly	28429
16	Inlet Spring	41143

Items 7, 8, 10, & 11 with a quantity of 2 each--may be ordered as a Double Pulley Assembly. Part No. 35600.
 Items 7, 9, 10, & 11 with a quantity of 1 each--may be ordered as a Single Pulley Assembly. Part No. 35598.

Linear Lift™ 800 Parts List

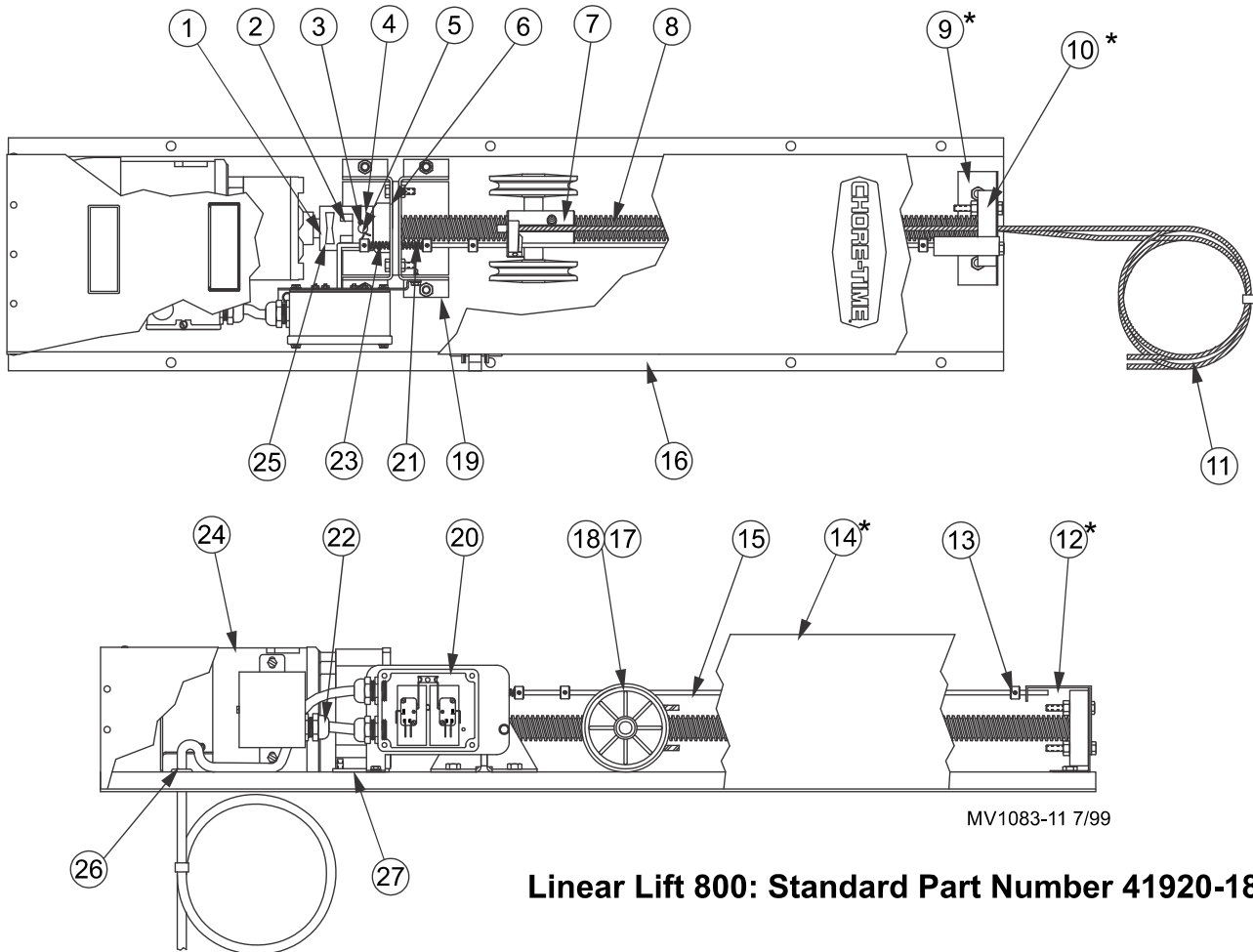

Linear Lift 800: Standard Part Number 41920-18

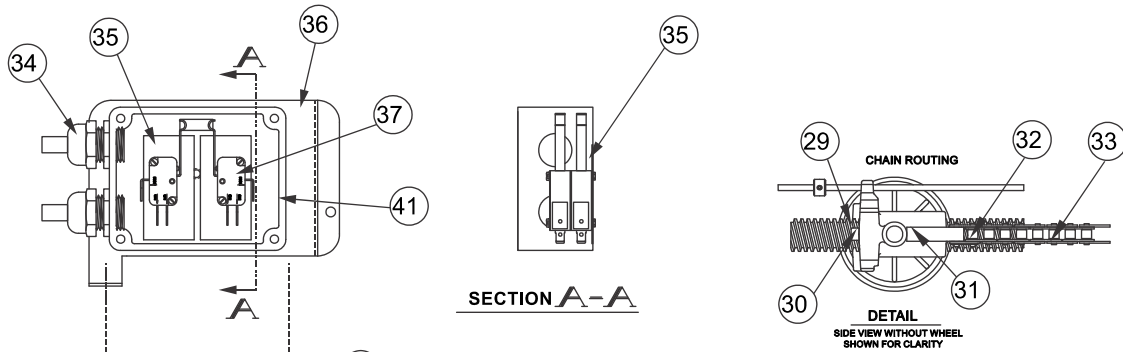

Linear Lift 800: Chain Version 44458-18

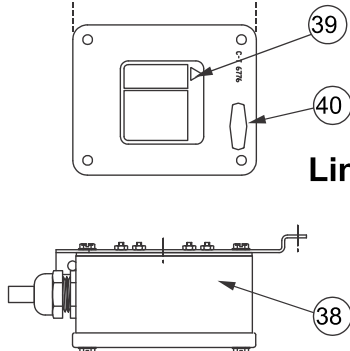

Linear Lift 800: Switch Assembly

Parts Listing and Identification

*Parts listed are Standard unless otherwise marked or stated.

Item	Description	Part No.
1	3/16 x 1 Square Key	2112-1
2	"Sox" Spider Spacer	36333
3	Cotter Pin	2663
4	Flexible Coupling	35944
5	Clevis Pin	36466-1
6	Thrust Plate	41911
7	Linear Lift™ Nut Assembly	41957
8	Threaded Shaft	35945-6
9	End Bracket	41913
10	Threaded Shaft Pilot	35569
11	Linear Lift™ Cable	41342
12	Rod Support	42385
13	Set Collar	41857
14	Cover Assembly	56086-1
15	Switch Rod	41915-1
16	Base	41912
17	Retaining Ring	41525
18	Machined Pulley Wheel	41540
19	LL 800 Thrust Bracket	42848
20	Switch Assembly	41916
21	Compression Spring	49813
22	Liquid Tight Connector	4999-95
23	Thrust Bearing	36397

Item	Description	Part No.
24	1/6 H.P. Gear Motor 28:1 Ratio	46379
25	Flexible Coupling	36363-3
26	Rubber Grommet	7256
27	Bison Motor Spacer	42859
*Chain Drive Version		
9*	Pilot End Bracket	44457
10*	Threaded Shaft Pilot	44413
12*	Rod Support	44459
14*	Cover Assembly	56086-2
29	1/4-20 x 1-1/2 Socket HD Cap Screw	5083-8
30	1/4-20 x 2-1/4 Socket HD Cap Screw	5083-2
31	Chain Connecting Rod	44417
32	Connecting Link (# 40)	20017
33	Drive Chain #10 (#40 Roller)	21045-12
Switch Assembly		
34	Liquid Tight Connector	23779
35	Switch Insulation	1907-8
36	Switch Mount Bracket	42857
37	Micro Switch	46324
38	Terminal Box	36334
39	Danger Decal	2527-35
40	Switch Box Cover	6776
41	Gasket	6777



**Made to work.
Built to Last.**

Note: The original, authoritative version of this manual is the [English] version produced by CTB, Inc. or any of its subsidiaries or divisions, (hereafter collectively referred to as "CTB"). Subsequent changes to any manual made by any third party have not been reviewed nor authenticated by CTB. Such changes may include, but are not limited to, translation into languages other than [English], and additions to or deletions from the original content. CTB disclaims responsibility for any and all damages, injuries, warranty claims and/or any other claims associated with such changes, inasmuch as such changes result in content that is different from the authoritative CTB-published [English] version of the manual. For current product installation and operation information, please contact the customer service and/or technical service departments of the appropriate CTB subsidiary or division. Should you observe any questionable content in any manual, please notify CTB immediately in writing to: CTB Legal Department, P.O. Box 2000, Milford, IN 46542-2000 USA.

Revisions to this Manual

Page No.	Description of Change	ECO
15	Changed Switch from 6049 to 46324	33946

**For additional parts and information, contact your nearest Chore-Time distributor or representative.
Find your nearest distributor at: www.choretime.com/contacts**

Chore-Time Group, A division of CTB, Inc.
PO Box 2000
Milford, Indiana 46542-2000 USA
Phone (574) 658-4101 Fax (877) 730-8825
Email: choretime@choretime.com
Internet: www.choretime.com