



Chore-Tronics® 3

Chore-Tronics® 3 Control Installation & Operator's Instruction Manual



For additional parts and information, contact your nearest Chore-Time distributor or representative.
Find your nearest distributor at: www.choretime.com/contacts

Chore-Time Limited Warranty

Instruments and Controls Group, a division of CTB, Inc. (“Chore-Time”) warrants new CHORE-TRONICS® Controls manufactured by Chore-Time to be free from defects in material or workmanship under normal usage and conditions, for One (1) year from the date of installation by the original purchaser (“Warranty”). If such a defect is determined by Chore-Time to exist within the applicable period, Chore-Time will, at its option, (a) repair the Product or Component Part free of charge, F.O.B. the factory of manufacture or (b) replace the Product or Component Part free of charge, F.O.B. the factory of manufacture. This Warranty is not transferable, and applies only to the original purchaser of the Product.

CONDITIONS AND LIMITATIONS. THIS WARRANTY CONSTITUTES CHORE-TIME’S ENTIRE AND SOLE WARRANTY AND CHORE-TIME EXPRESSLY DISCLAIMS ANY AND ALL OTHER WARRANTIES, INCLUDING, BUT NOT LIMITED TO, EXPRESS AND IMPLIED WARRANTIES, INCLUDING, WITHOUT LIMITATION, WARRANTIES AS TO MERCHANTABILITY OR FITNESS FOR PARTICULAR PURPOSES. CHORE-TIME shall not be liable for any direct, indirect, incidental, consequential or special damages which any purchaser may suffer or claim to suffer as a result of any defect in the Product. Consequential or Special Damages as used herein include, but are not limited to, lost or damaged products or goods, costs of transportation, lost sales, lost orders, lost income, increased overhead, labor and incidental costs, and operational inefficiencies. *Some jurisdictions prohibit limitations on implied warranties and/or the exclusion or limitation of such damages, so these limitations and exclusions may not apply to you. This warranty gives the original purchaser specific legal rights. You may also have other rights based upon your specific jurisdiction.*

Compliance with federal, state and local rules which apply to the location, installation and use of the Product are the responsibility of the original purchaser, and CHORE-TIME shall not be liable for any damages which may result from non-compliance with such rules.

The following circumstances shall render this Warranty void:

- Modifications made to the Product not specifically delineated in the Product manual.
- Product not installed and/or operated in accordance with the instructions published by the CHORE-TIME.
- All components of the Product are not original equipment supplied by CHORE-TIME.
- Product was not purchased from and/or installed by a CHORE-TIME authorized distributor or certified representative.
- Product experienced malfunction or failure resulting from misuse, abuse, mismanagement, negligence, alteration, accident, or lack of proper maintenance, or from lightning strikes, electrical power surges or interruption of electricity.
- Product experienced corrosion, material deterioration and/or equipment malfunction caused by or consistent with the application of chemicals, minerals, sediments or other foreign elements.
- Product was used for any purpose other than for the care of poultry and livestock.

The Warranty may only be modified in writing by an officer of CHORE-TIME. CHORE-TIME shall have no obligation or responsibility for any representations or warranties made by or on behalf of any distributor, dealer, agent or certified representative.

Effective: **April, 2014**

Contents

Topic	Page
Chore-Time Limited Warranty	2
General	5
Support Information	5
Safety Information	5
Follow Safety Instructions	5
Decal Descriptions	5
Introduction to the Control	6
Display Screen	6
Navigation	6
Relay Box Indication Lights and Auto/Manual Switches	11
Glossary of Terms	12
Analog Input	12
Anticipation	12
Back Up Relay Output	12
Bend Point (BP)	12
Cool Pad Output	12
Curve	12
Curve Value	12
Day Number	12
Digital Input	13
Event	13
Mode Sensor(s)	13
Natural Mode	13
Offset	14
Power Mode	14
Program	14
Set Temperature	14
Spare Temp Sensor	14
Static Pressure	15
Tunnel Mode	15
Wind Delay	15
Overview of Screens	16
Alarms (Active or Recovered)	16
Control Setup	18
General Setup	18
Analog Inputs	21
Analog Input Calibration	28
Digital Inputs	31
Setup House	36
Output Assignments	37
Assignments	52
Ventilation Settings	55
Curves	64
Management Screens	68
Programs/Setup Key Screens	73
Clocks	79
History	83
User Levels	89
Control Operation Overview	93

Contents - continued

Topic	Page
Standard Mode Functionality	93
Control Installation	94
Mounting the Control	94
Wiring the Control	98
Analog Inputs	100
Remote Light Dimmer Control Wiring	108
Bird Scale Wiring using the LCC Board (Scales Less than 150' from Control)	109
Bird Scale Wiring using the LCC Board (Scales More than 150' from Control)	110
Testing the Back Up Box	114
MS Board Dip Switch Positions	116
PC Connection	117
PC on the farm without internet	117
PC on the farm with internet.	117
Troubleshooting	118
Programming Trouble Shooting	118
Programming Troubleshooting Continued.....	120
Programming Trouble Shooting Continued.....	121
Equipment and Potentiometer Troubleshooting	121
Equipment and Potentiometer Troubleshooting Continued.....	123
Equipment and Potentiometer Troubleshooting Continued.....	125
Equipment and Potentiometer Troubleshooting Continued.....	126
Equipment and Potentiometer Troubleshooting Continued.....	127
IONet Error Addr:xx.	128
Wiring Diagrams	129
Backup Control Wiring (24Vdc)	129
Fan Wiring	130
Linear Lift Wiring Diagram	131
Turbo-Cool™ Wiring	132
I/O Board Wiring	132
Brooder Wiring	134
Improving Lightning Surge Suppression	136
Itemized Parts (Main Box).....	140
Parts Listing (Main Box)	141
Itemized Parts (Relay Box)	142
Parts Listing (Relay Box).....	143
Extra Parts and Kits.	144
Analog Input Add-On Kit (Part No. 49663).	144
Digital Input Add-On Kit (Part No. 49665)	144
Expansion Board Kit (Part No. 49667).	144
IMSCM.8 Red Repair Board (Part No. 49672)	144
IMSCM.16 Red Repair Board (Part No. 49673)	144
Input Wiring Assignment Diagram	145
Technical Specifications.....	146

General

Support Information

The Chore-Tronics® 3 Controls are used to control the Climate in a structure to insure efficient growth of Livestock. Using this equipment for any other purpose or in a way not within the operating recommendations specified in this manual will void the warranty and may cause personal injury.

This manual is designed to provide comprehensive planning, installation, safety, operation, and parts listing information. The Table of Contents provides a convenient overview of the information in this manual. The Table of Contents also specifies which pages contain information for the sales personnel, installer, and consumer (end user).

Safety Information

Caution, Warning and Danger Decals have been placed on the equipment to warn of potentially dangerous situations. Care should be taken to keep this information intact and easy to read at all times. Replace missing or damaged safety decals immediately.

Using the equipment for purposes other than specified in this manual may cause personal injury and/or damage to the equipment.

Follow Safety Instructions

Carefully read all safety messages in this manual and on your equipment safety signs. Follow recommended precautions and safe operating practices.

Keep safety signs in good condition. Replace missing or damaged safety signs.

Decal Descriptions

DANGER: Electrical Hazard

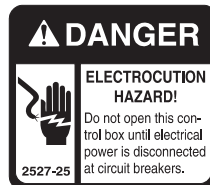

Disconnect electrical power before inspecting or servicing equipment unless maintenance instructions specifically state otherwise.

Ground all electrical equipment for safety.

All electrical wiring must be done by a qualified electrician in accordance with local and national electric codes.

Ground all non-current carrying metal parts to guard against electrical shock.

With the exception of motor overload protection, electrical disconnects and over current protection are not supplied with the equipment.

Introduction to the Control

Display Screen

The display screen is a 10.1 in. Full Color Touch screen. This screen will display the requested information when an Icon on the Touch Screen is pressed. The Display Screen always remains lit. When the Control is left dormant, the Current Conditions Screen will be visible.

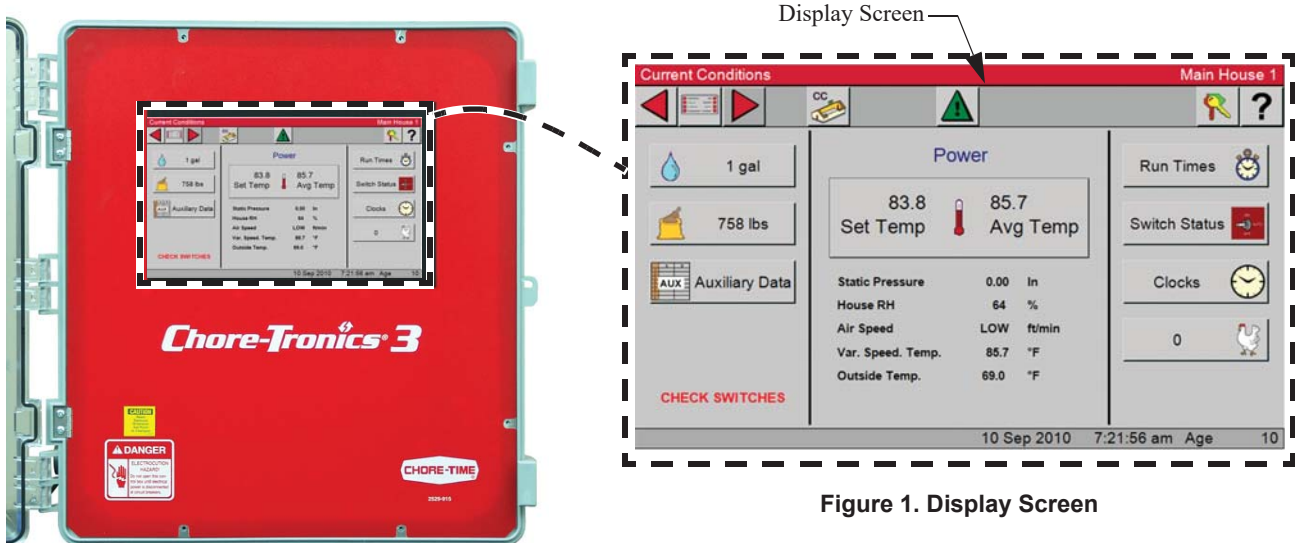

Figure 1. Display Screen

Navigation

Navigating the Control can be done in one of two ways.

Navigating option 1. (Touch)- Touch the Icon or simulated button displayed on the screen with your finger or stylus.



Figure 2. Navigation-Touch

Navigating option 2. (Mouse)- A USB mouse can be used by plugging it into the USB port located on the left side of the main Control Box.

To navigate using a mouse, position the cursor on the Icon or the simulated button displayed on the screen, and press the left mouse button to select.



Figure 3. Navigation-Mouse

Screen Layout

In the top left corner of every screen the path and the screen name is displayed to the screen you are viewing. In this example the Current Conditions screen is displayed.

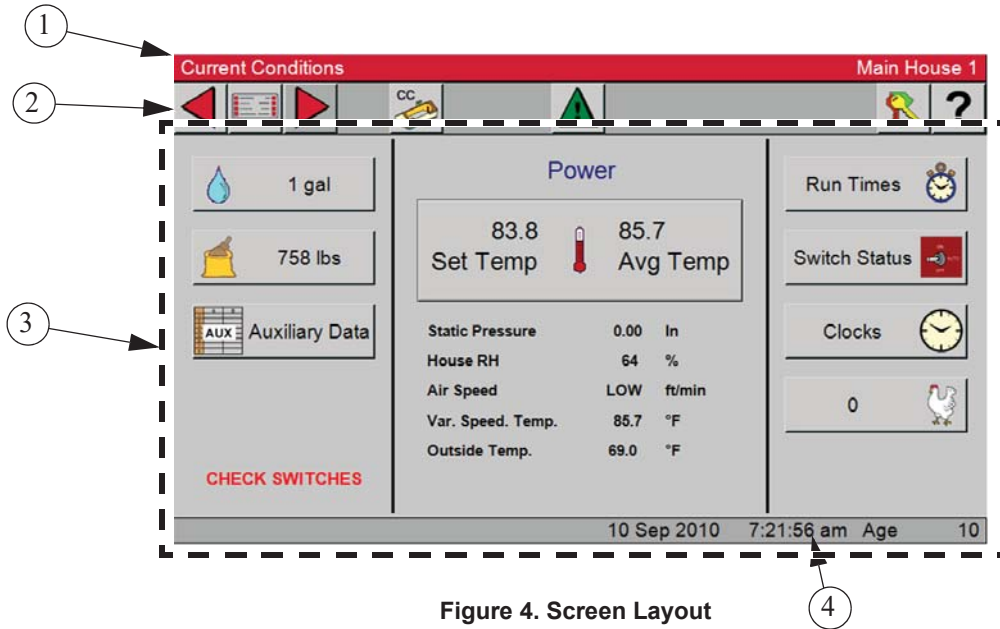



Figure 4. Screen Layout

1. Displays the Path and the house name or number.
2. (Task Bar) Navigation buttons from left to right are; Back button, Main menu, Forward button, Current Condition, Alarm, Password and the Help.
3. All menus, viewable data and editable fields.
4. Time, Date and Age.

Navigating the Control's Screens

In the Current Conditions screen you can view current data and some settings. Each button has an Icon that represents the data to be displayed.

Selecting the button with the water droplet  will display the current water usages from 12:00 am.

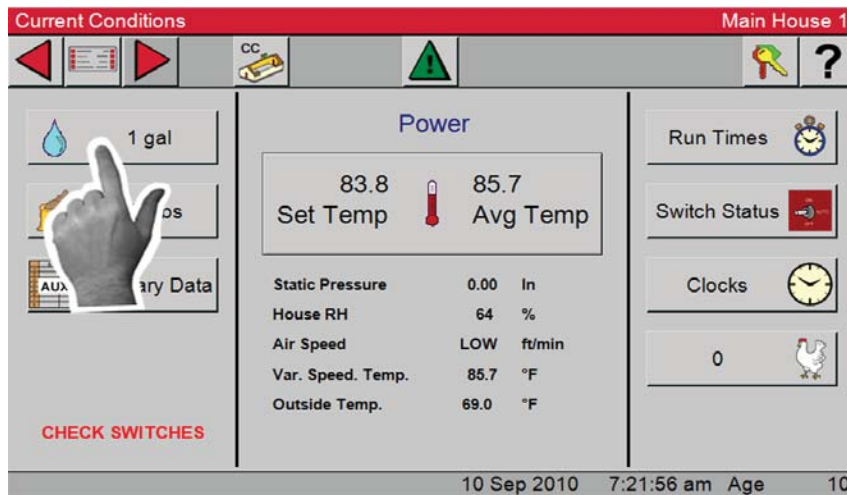

Figure 5. Screen Navigation

Notice the path displayed (Current Condition/Today's Water)

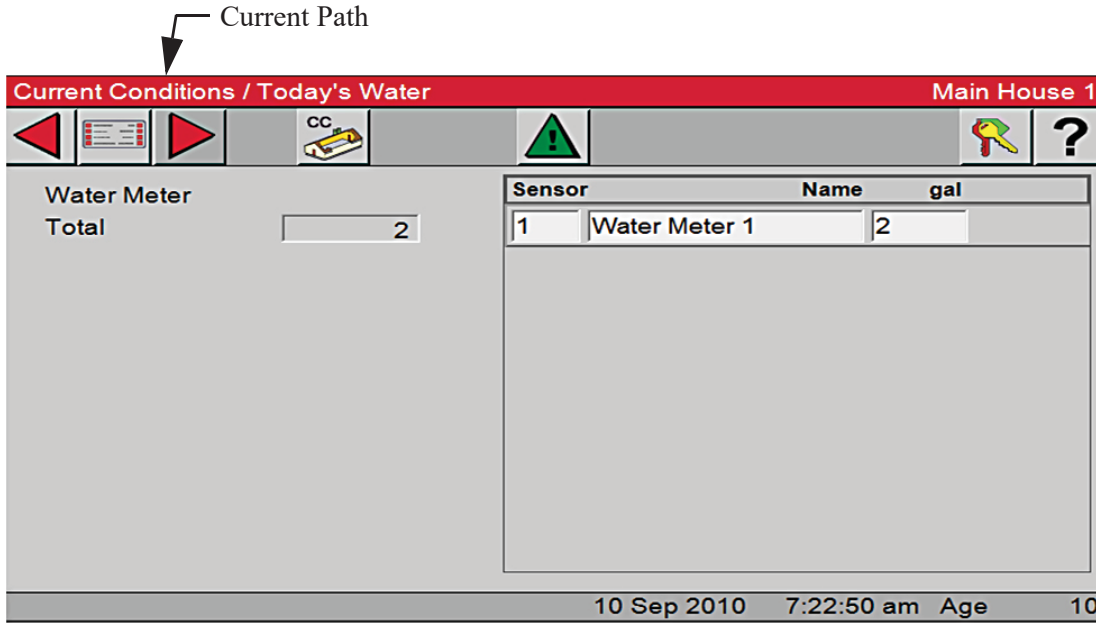



Figure 6. Current Path

To return to the Current Conditions screen, select the back  button at the top left corner of the screen, or select the CC  button. Note: Regardless of the screen you are in selecting the CC button will return you back to the Current Conditions screen.

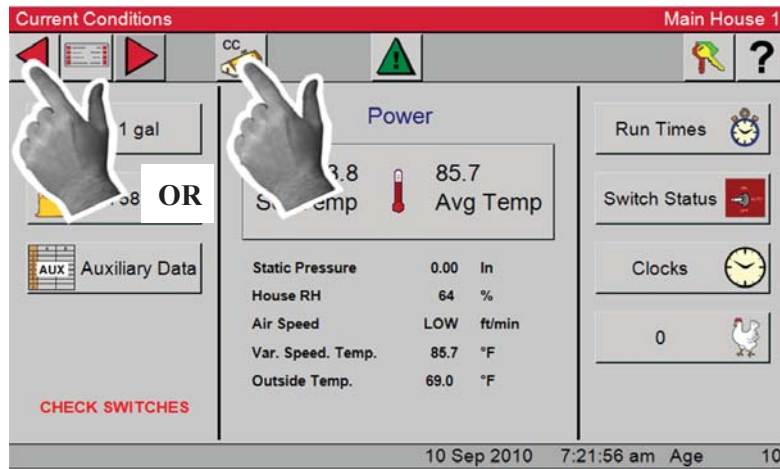

Figure 7. Returning to Current Conditions Screen

Numeric Keypad

In a screen that has editable fields, select the value you want to edit (In this example: Set Temperature). A Numeric Key Pad will be displayed. The name of the field will be displayed at the top of the Key pad.

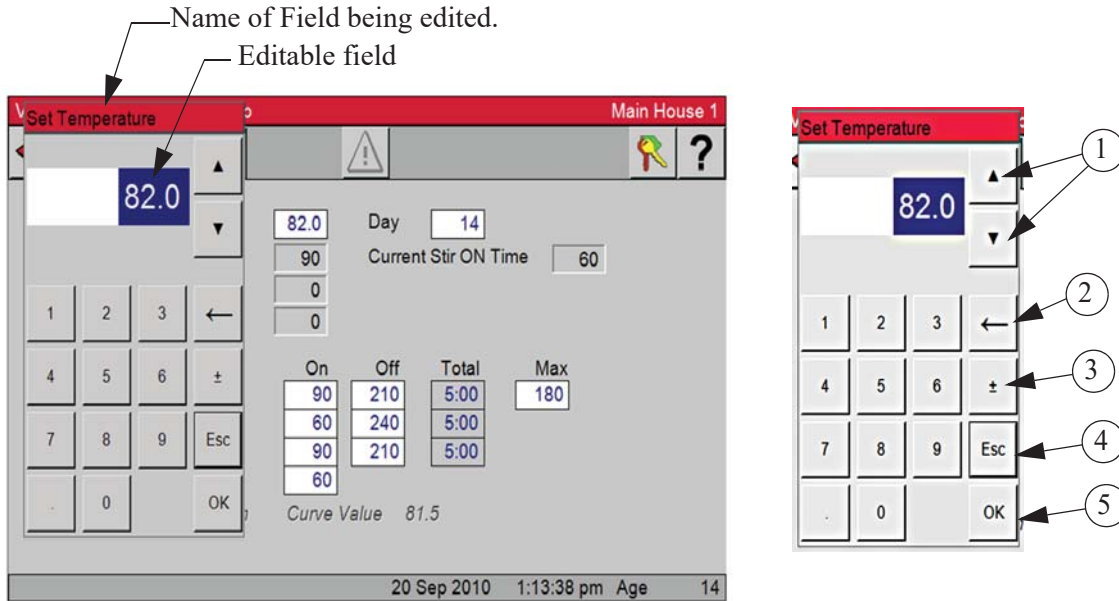

Figure 8. Numeric Keypad

1. Scrolls the value up or down.
2. Removes the last number on the right.
3. Changes the entre from a positive to a negative.
4. Removes the pop up with no changes to the value.
5. After you have made changes select "OK" to confirm the change. The pop up will disappear and the change will be displayed in the field.

In some editable fields you can enter text, if these fields are selected a Key Board will be displayed. If a number is needed with the text, select the button labeled 123 on the Key Board and a Numeric Key Pad will be displayed. To go back to the Key Board select the AZ button on the Numeric Key Pad. The OK button will save your entry.

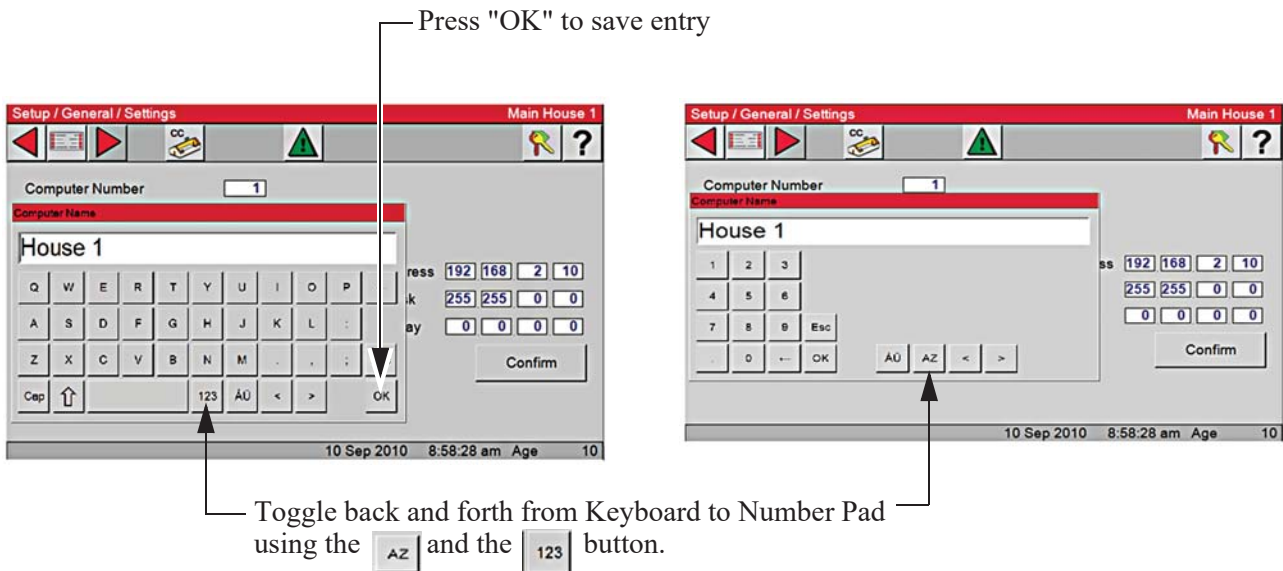
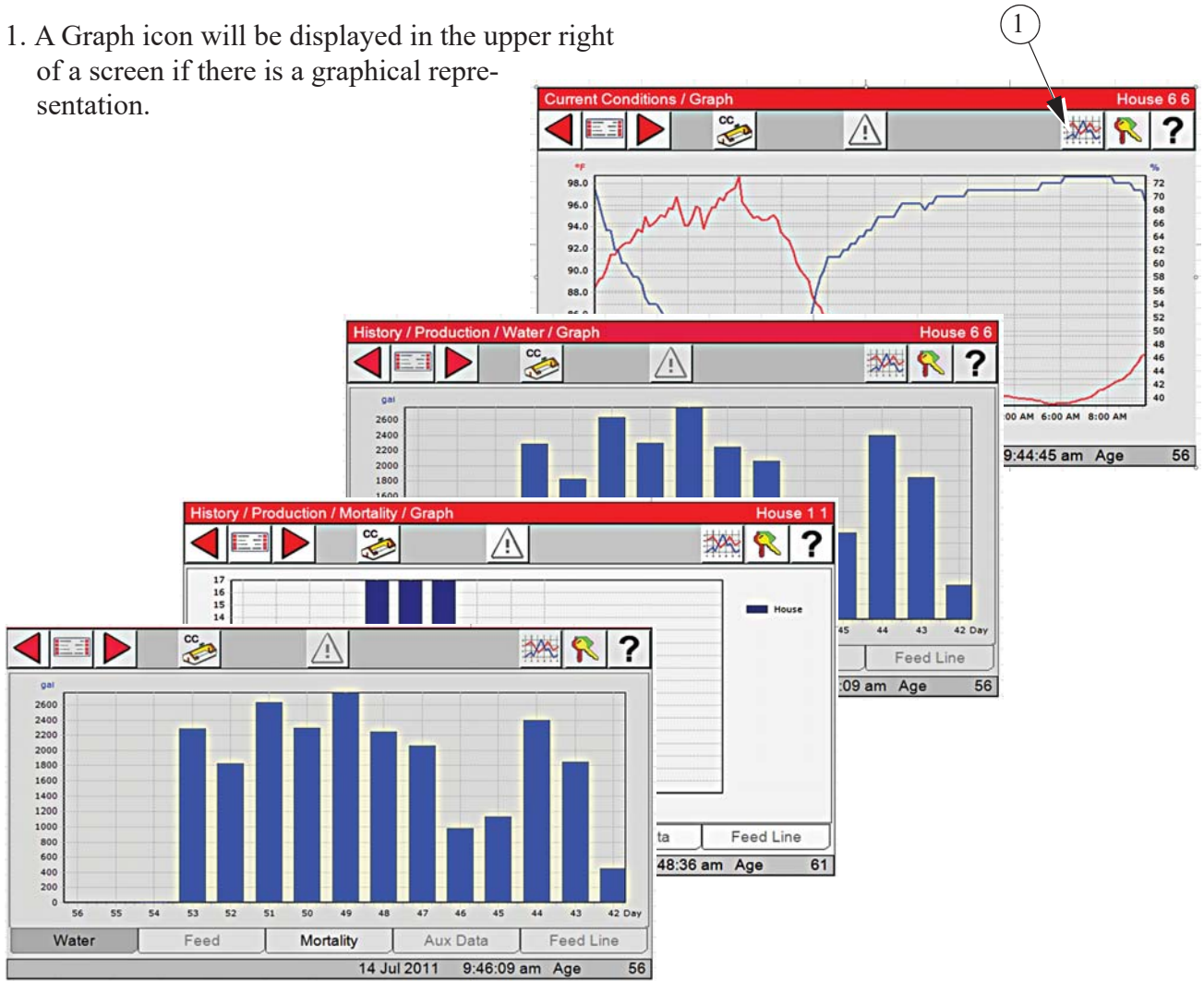

Figure 9. Toggling between Keyboard or Numeric Key Pad

Graphs

1. A Graph icon will be displayed in the upper right of a screen if there is a graphical representation.



Relay Box Indication Lights and Auto/Manual Switches

Each Relay Output has its own three position switch that allows the user to select manual, off or automatic control of each Relay. The Relays and their corresponding Switches are located in a separate box. Decals are supplied to label each Switch for the Output function that is assigned to that Switch. The Switches can be placed in three positions - "on", "off", or "auto". The "auto" position is for normal automatic operation. Changing a Switch to "on" or "off" overrides "auto" operations. When a switch that is assigned is placed in a position other than "auto", a message will appear in the Current Conditions screen advising you to "Check Switches". The light above each Switch indicates that the Switch's Relay is activated.

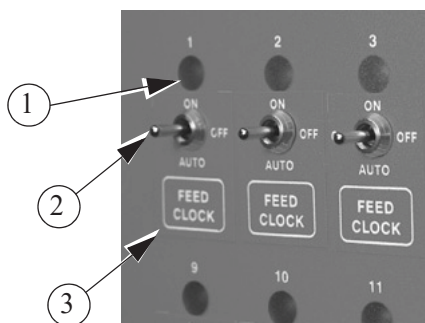

Item	Description
1	Indication Light
2	Switch
3	Decal

Figure 10. Indication Lights and Switches

Glossary of Terms

Analog Input

Analog Inputs can consist of the following:

Temperature sensors

Static Pressure sensor (4-20 mA)

Relative Humidity Sensor (0-10 volts)

Potentiometer (Natural Ventilation)

Anticipation

When the control is turning on the fans assigned to the Minimum Ventilation Timer, the control will open the inlets to the correct position for static pressure control before the fans are turned on. If calculated anticipation is used (default), the control teaches itself how much adjustment was required during the previous on-off cycle, and uses that amount of "anticipation" for the next cycle. If the optional fixed anticipation is used, the control will NOT teach itself what the correct anticipation should be. It uses the amount of "anticipation" that is entered in the Static Pressure screen (Screen 11). Anticipation will occur when the fans assigned to the Minimum Ventilation Timer turn on due to the timer reaches an ON cycle or the sensor(s) assigned to the fans reach the fans' ON temperature.

Back Up Relay Output

The backup up relay output is a relay that will be energized as soon as the backup output is assigned to a relay. This relay will stay energized as long as the control is communicating with the manual switch board where the output is assigned. The 24 Vdc signal that comes from the control to the back up box should be routed through this relay. If communication is lost between the main box and the manual switch board, the relay will drop out allowing the first fan stage in the back up box to turn on. See the Wiring Diagrams section of this manual for more wiring information.

Bend Point (BP)

The Bend Points (BPs) are simply the points on the curve that define the curve. For the Set Temperature and Minimum Ventilation Timer curves, the curve values are gradually changed between bend points. The bend point values are the exact values at midnight beginning the day # of each bend point. The curve takes over when you turn the curve "on" and the day number is equal to or greater than the day number assigned to BP #1.

Cool Pad Output

The COOL PAD Output is a special function for controlling evaporative cooling that allows you to modulate the addition of water to the cooling pad in such a way that the usual large temperature swings associated with a cooling pad are avoided.

Curve

A "curve" is a listing of up to 10 points in time (bend points) that defines how you want a parameter to automatically vary as the animals age.

Curve Value

The Control will list what the current value(s) the curve would be, if the current day number is greater than the day # of bend point #1, and the curve is "on", and there is no "offset" to the curve.

Day Number

The intention is that the day # is the age of the animals whose environment is being controlled. Day # 0 does not exist. Negative days (down to - 7) are allowed. Changing the day # in any screen that shows the day number, will change the day # in all the other screens that show the day #.

Digital Input

Digital Inputs can consist of the following:

Water meter

Feed scale

Air speed sensor

Low water pressure switch

Max feed run time Input

PDS flush feed back

Event

This term applies to the time clock Outputs. An "event" is an "on at" time combined with an "off at" time.

Mode Sensor(s)

The concept of Mode Sensor(s) is essential to the understanding what makes the Control change from one mode to another. The Mode Sensor(s), of a currently operating mode, determines when the Control will leave that mode. As an example, while in the Power Mode, the Power Mode Sensor(s) determines when it's too hot to stay in the Power Mode (i.e. above the tunnel "on" temperature). Because of this, it converts to the Tunnel Mode (assuming there is no Natural Mode) at the tunnel "on" temperature. It comes back to the Power Mode from the Tunnel Mode, when the Tunnel Mode Sensor(s) say it's too cold to stay in the Tunnel Mode (i.e. below the tunnel "off" temperature).

Natural Mode

Natural Mode requires the house to be equipped with Curtains in the side walls that are powered by Drive Units (Curtain Machines). The Control converts to this mode of operation when the temperature(s) inside the house raise to a level that the Fans of the Power Mode can't keep the temperature(s) under control. While in the Natural Mode of operation, the Curtains are opened or closed, as required, to control the temperature(s). This mode of operation generally happens during moderate weather.

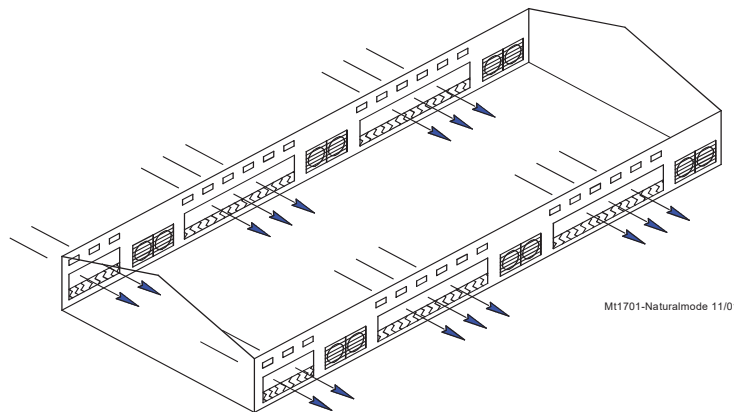

Noticing an Alarm

"Noticing" an alarm is a very important part of using the alarm system. See how to Notice an Alarm (Active or Recovered) in the "Alarm" section of this manual.

Offset

The term "offset" applies to the Set Temperature and Minimum Ventilation Timer curves only. If you manually adjust either the Set Temperature or the Minimum Ventilation Timer settings, while the curve is on, you create an "offset" to that curve relative to its "curve value". The "curve value" is not changed. (see the "curve value" definition above.) The curve value is shown as a convenience so that you know what you have to change it back to in order to get back on the actual curve's table listing. While an "offset" is in effect, the parameter of the curve is still modified versus time. However, the actual parameter value is the "curve value" modified by the "offset".

Power Mode

The building is closed up except for Inlets (usually Baffle Doors) which are powered open and close in order to control the static pressure level. In some cases Gravity Inlets are used where the static pressure is not controlled directly. The only ventilation provided is due to Fans mounted in the end or side walls. This mode of operation generally happens when the outside temperatures are somewhat lower than the set temperature.

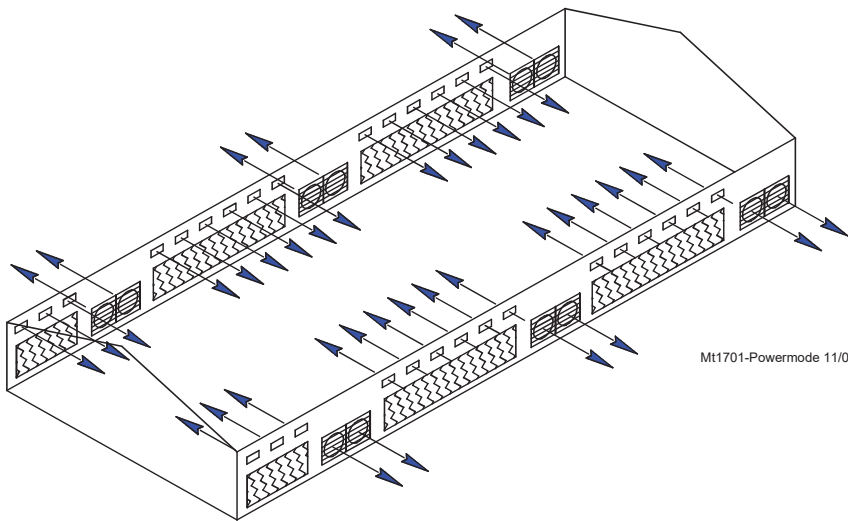

Program

A "program" is a complete set up of all the screens of a Control. In the main menu Program Tab, six different "programs" can be saved and later activated. This can be very convenient when it is desired to change the set up at different points during the grow out, barn cycle, or times of the year.

Set Temperature

The set temperature is another very important, basic, concept. All temperatures are referenced to the set temperature. When the set temperature is adjusted either manually, or because the set temperature curve is on, all other temperature settings move up or down by the same amount. For instance, even though you program an actual temperature for each Fan to come on and off, when you change the set temperature, those Fan's on and off temperatures are adjusted by the same amount you changed the set temperature.

Spare Temp Sensor

The spare temperature sensor is a temperature sensor that is separate from one of the 12 controlling sensors. This sensor can be used to control the temperature in a separate area of the house. The sensor has its own maximum and minimum alarm parameters that can be set up in the Alarms screen. The sensor can also turn on and off the Spare Temperature Sensor Output. This output functions like a fan output. The output has lower Off temperature than its On temperature. The On and Off temperatures for the Spare Temperature Sensor output are defined in the Outputs and Temperatures screen. The spare temperature sensor can not be used to control any other output.

Static Pressure

Static pressure refers to the pressure difference that exists between the inside of the house and the outside of the house. This pressure difference is the result of Fans in the walls running. The air that they exhaust enters the house through various types of air inlet openings. In the Power Mode the typical powered baffle inlets is where the vast majority of the air enters. In the Tunnel Mode, the tunnel inlet at the end of the house is where the air enters. The pressure drop, due to the resistance to the air flowing through the inlets, is the reason a static pressure difference exists. If the inlets are all the same size, the same amount of air will enter through each inlet. In the Natural Mode of operation, the outside wind is the source of the air, with no exhaust fans running. In general there is little or no static pressure during the Natural Mode due to the huge area of the open side wall curtains. When the incoming air is cooler than the inside air, it will tend to drop down onto the birds before it is warmed up. Adequate static pressure brings the air into the house high and fast so that it heats up before it can fall.

Tunnel Mode

This mode of operation requires a group of large fans at one end of the house with a large air Inlet area at the opposite end of the house. The control converts to this mode of operation from the Power or Natural Mode (if used), when the temperature(s) while in those modes get too high. The typical 5 or 6 mph. breeze, which can be created by the Tunnel Fans running, produces a wind chill effect that is significant. This mode of operation happens during warm to hot weather.

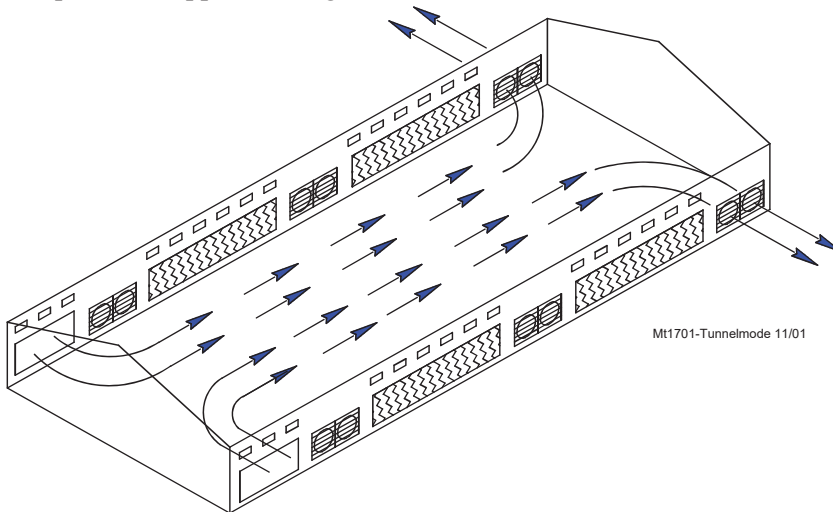

Wind Delay

The static pressure has to be out of the control limits continuously for the "wind delay" amount of time before the inlets are adjusted. If a fan or fans has turned on or off within the last 10 seconds, the wind delay does not happen and the inlets respond as soon as the static pressure leaves the control limits.

Overview of Screens

Alarms (Active or Recovered)

Active Alarms

To see any current "Active" alarms press the Alarms Button. If there are any Active alarms they will be listed here (See Figure below).

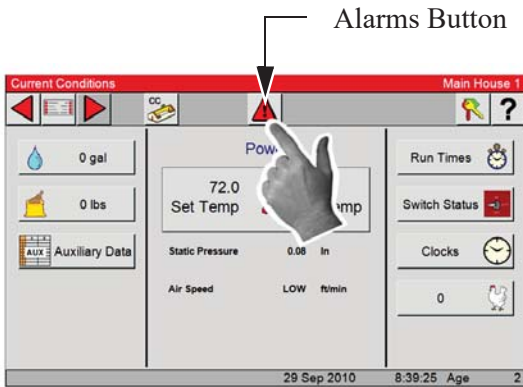

From any screen you can select the Alarm button. This will take you to the Alarm Overview screen.

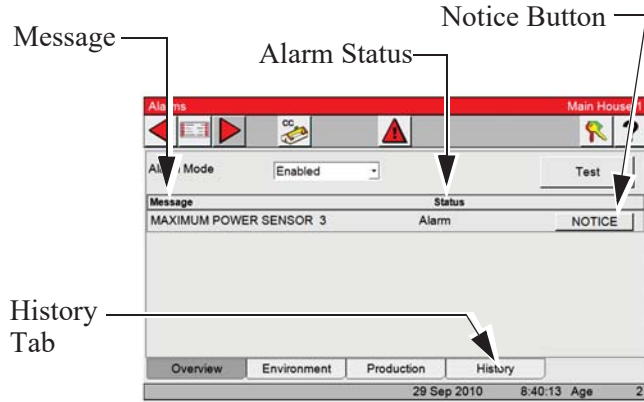

Alarm Overview Screen- In the Alarm Overview screen an Alarm is listed in three columns. Message (Type of alarm), Status (Alarm, Recovered and Off For) and a Notice button.

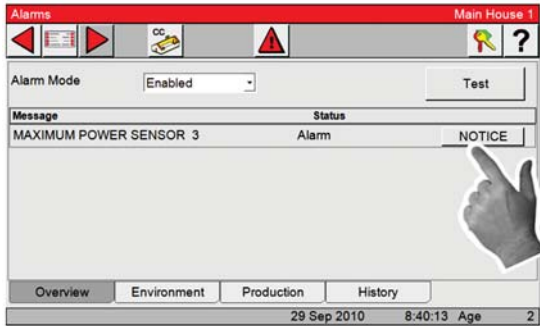

Active Alarm- Select the **Notice Button** to notice the Alarm

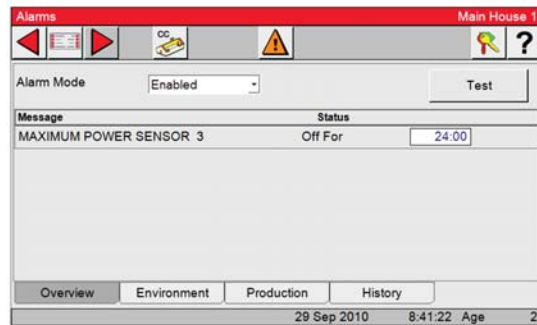

If the alarm condition is still active, Off For x:xx will be displayed in the Status column. The specific alarm will be inactive until it has recovered to within its normal range, at that point the alarm will be sent to the Alarm History (See below left).

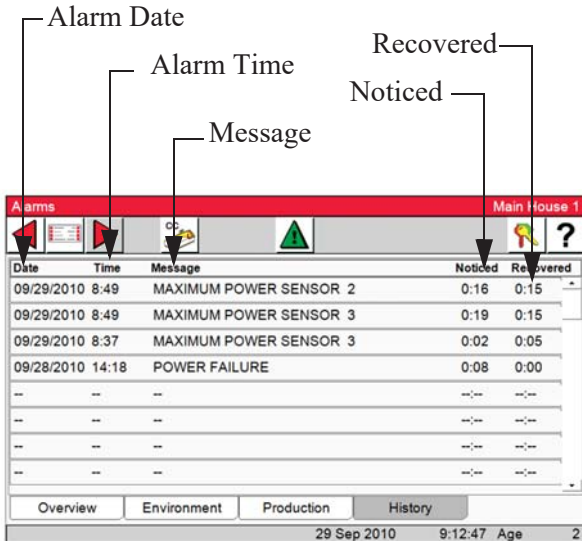

Recovered Alarms

To see "Recovered" alarms press the Alarms Button. If there are any Recovered alarms they will be listed here (See Figure below)

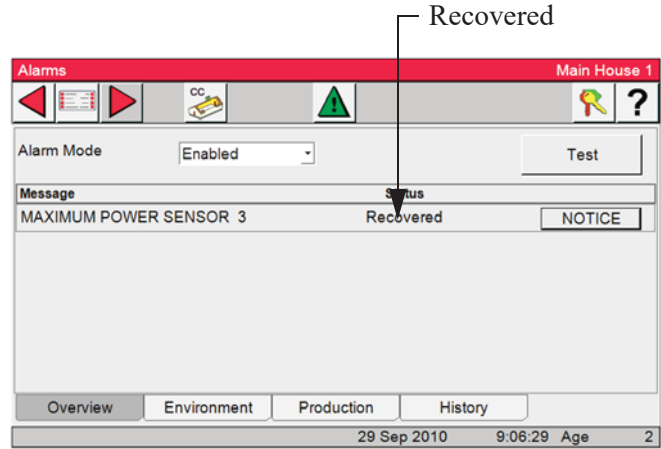
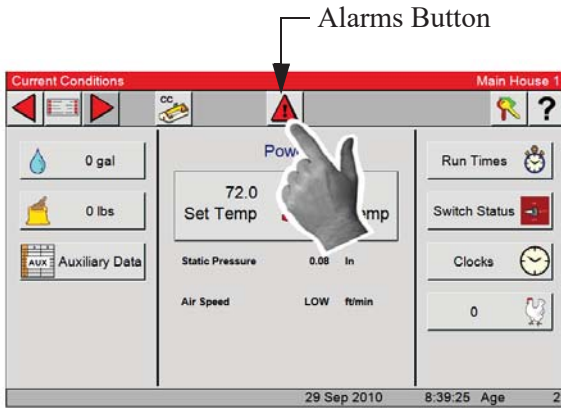

From any screen you can select the Alarm button. This will take you to the Alarm Overview screen.

Alarm Overview Screen- If there is a Recovered alarm it will be listed here (See above).

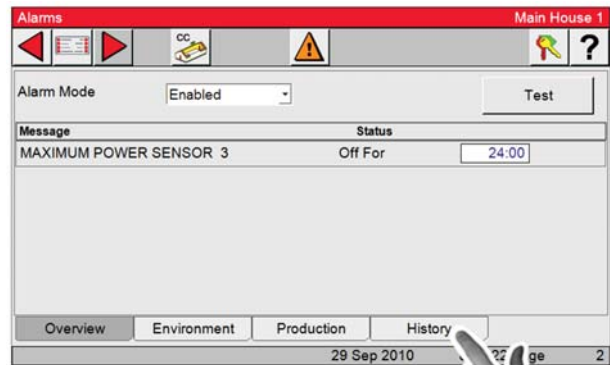
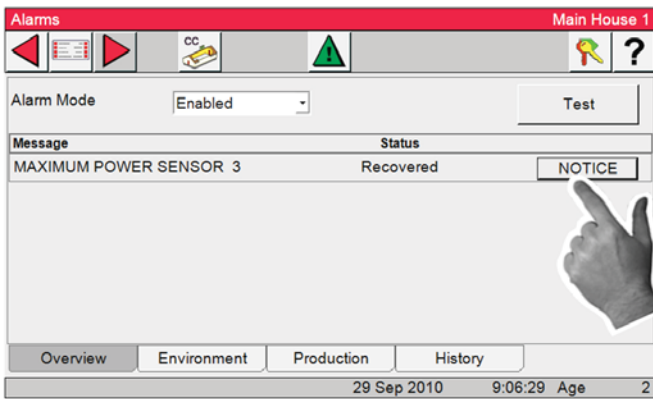

Notice Button- Select the Notice button to notice the alarm, the alarm will be sent to the Alarm History screen.

Alarm History- To view the alarm history, select the History tab at the bottom of the Alarm screen. The alarm date, time, message, noticed and recovered is displayed for each alarm listed (See below).

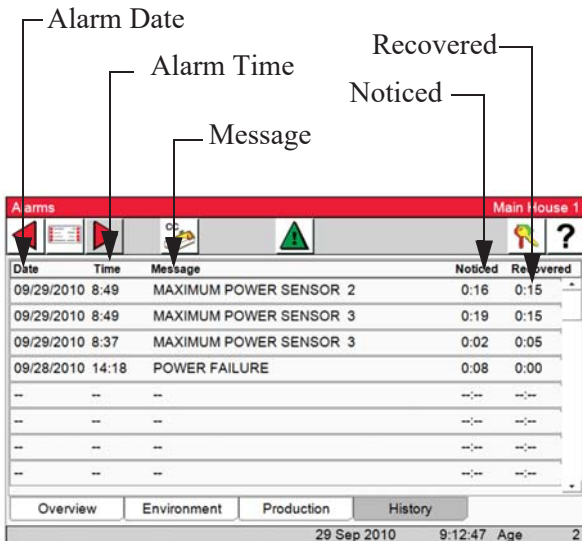

Control Setup

General Setup

From any screen select the Main Menu  button at the top left of the screen.

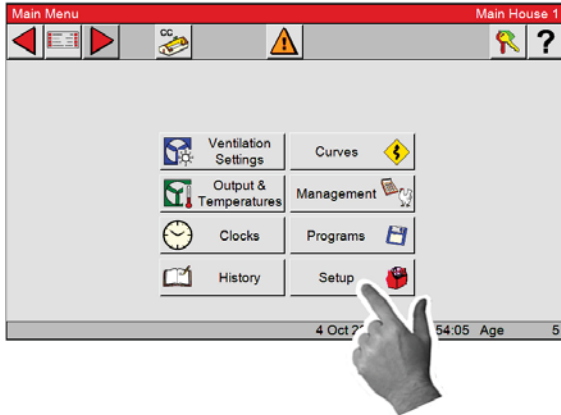

1. Select the Setup button.

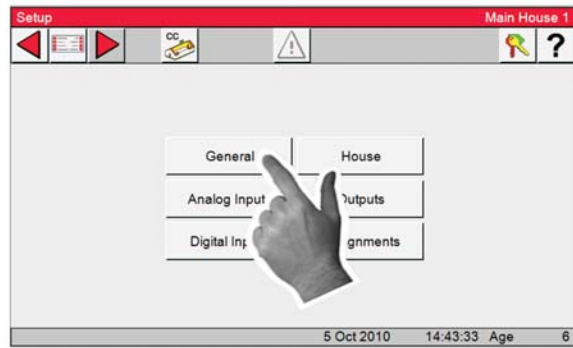

2. Select the General button to access the Setup/General screen.

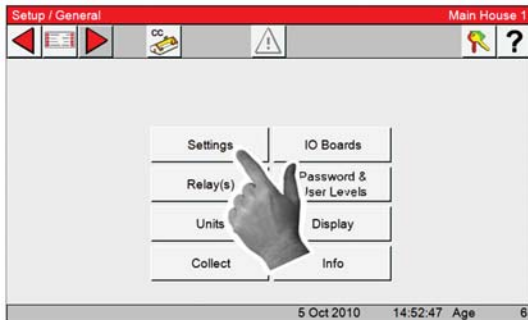

3. From the Setup/General screen select Settings .Setup/General/Settings screen.

Note: Path to the Screen being viewed

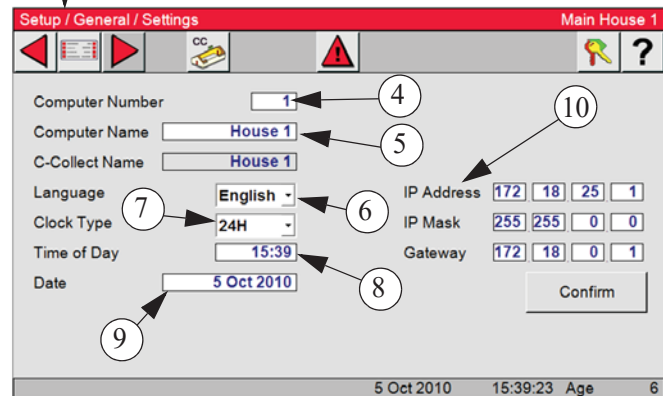

4. Enter the Computer Number. This will be your house number.
5. Enter the House Name. The house name can be whatever you want, it will be displayed at the top right of every screen. A maximum of 14 digits.
6. Choose the Language by pressing the dropdown and select English or Spanish.
7. Choose the Clock Type by pressing on the dropdown and select 12 hour or 24 hour clock.
8. Set the Time of Day by pressing on the time box, a numeric keypad will open allowing you to set the time of day. **(See following page).**
9. Set the Date by pressing the date box, a numeric keypad will open allowing you to set the date. Follow the same procedure used to set the Time **(See Following Page).**
10. The IP, IP mask and Gateway are used only if C-Central, WebLink and or C-Collect are in use. These settings are determined by the local network settings.

Setup / General / Settings Main House 1

Computer Number

Computer Name

C-Collect Name

Language IP Address

Clock Type IP Mask

Time of Day Gateway

Date

5 Oct 2010 15:39:23 Age 6

Time of Day

4 : 06 pm

1 2 3 ←

4 5 6

7 8 9 Esc

. 0 OK

Time of Day

1. Highlight the hours by selecting the hours. Change the hours by using the up/down arrows or the keypad.
2. Highlight the minutes by selecting the minutes. Change the minutes by using the up/down arrows or the keypad.
3. Highlight the am/pm by selecting the am/pm. Use the up/down arrows to toggle.
4. Select OK to save.

Date

The date must be enter in a specific format (Day.Month.Year)
The example shows, 05.10.2010 for 5 October 2010

Date

05.10.2010

5 Oct 2010

1 2 3 ←

4 5 6

7 8 9 Esc

. 0 OK

Units

In this screen you will choose the unit of measurement you want to display.

1. Select the General Button in the Setup Screen.

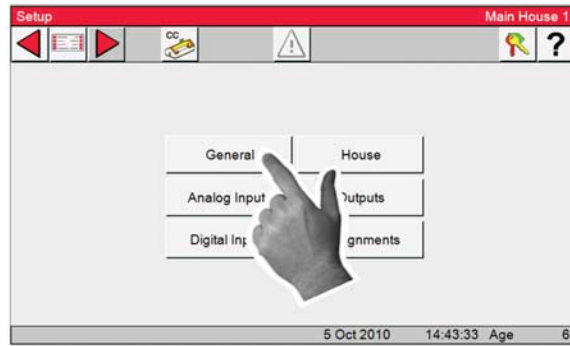

2. Select the Units button

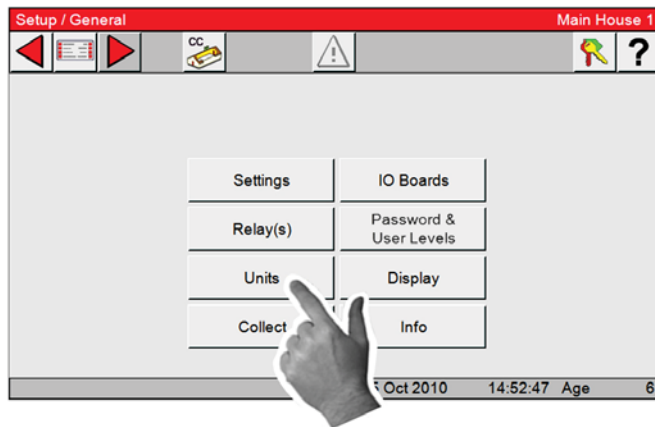

3. Choose the unit of measurement you want to display.

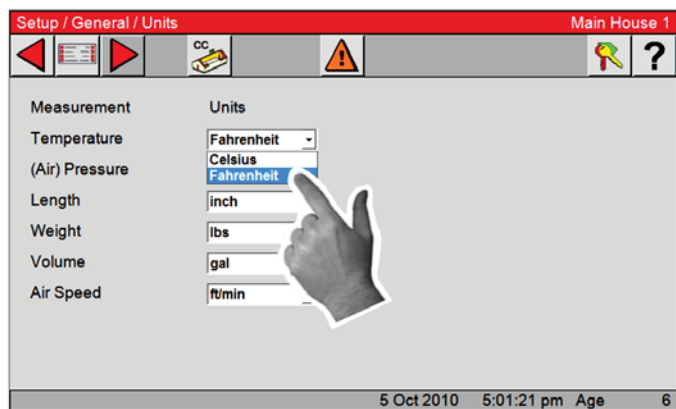

Analog Inputs

To access the Analog Inputs Setup screen start by accessing the Main Menu  screen.

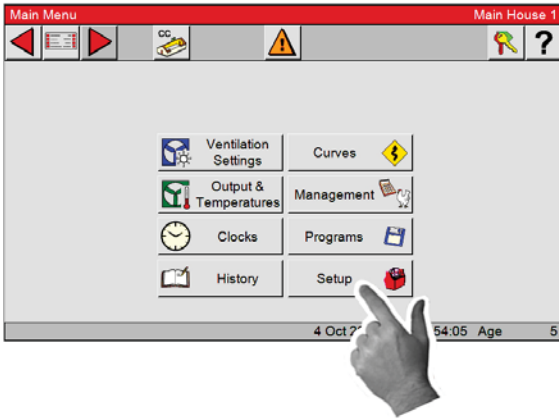

1. Select the Setup button.

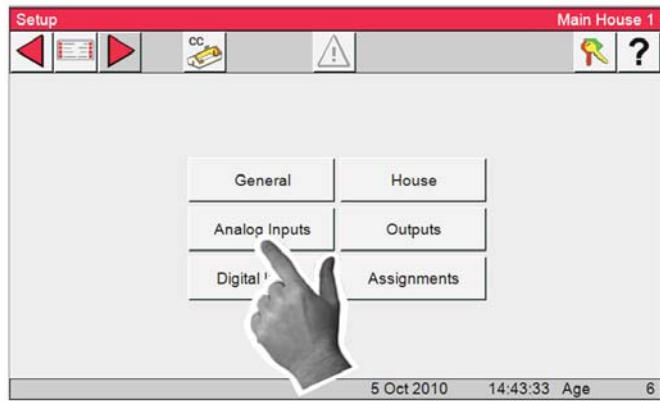

2. Select the Analog inputs

Analog Inputs-Sensor Type

Grayed out (Cannot select) Sensor Types Installed
Number of Sensors

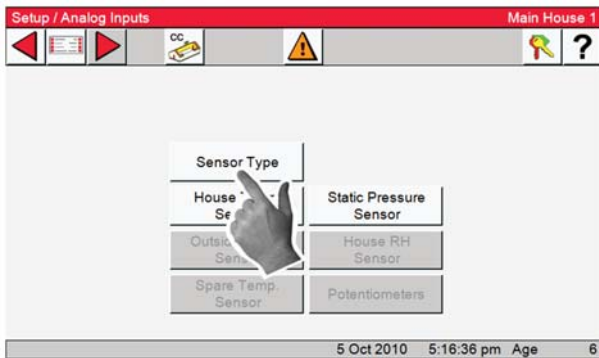

1. Select the Sensor Type button

In this screen you choose what type of Analog Inputs (temperature sensors, relative humidity sensor, and potentiometers) are connected to the Control. The Static Pressure Sensor and House Temperature Sensors 1-3 come from the factory pre-assigned.

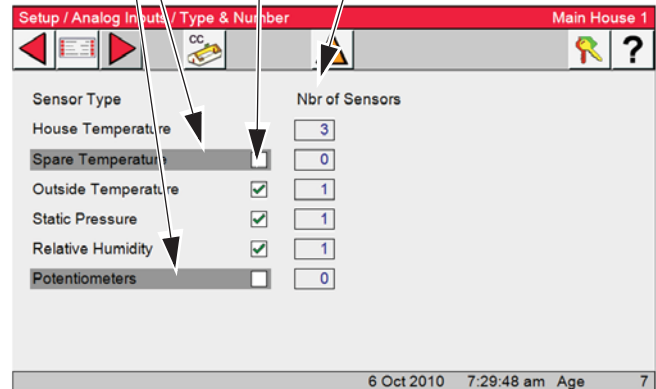

2. Enter Sensor Types installed

Select the box to the left of the sensor types installed. When a Sensor type is grayed out, that specific item cannot be selected. The number of specific sensors (Nbr Sensors) will be added as you continue with setup.

Analog Inputs-House Temperature Sensors.

1. Select the House Temp. Sensor button

From the Setup/Analog Inputs screen select House Temp. Sensors button. The Setup/Analog Input/House Temperature screen should be displayed at this time

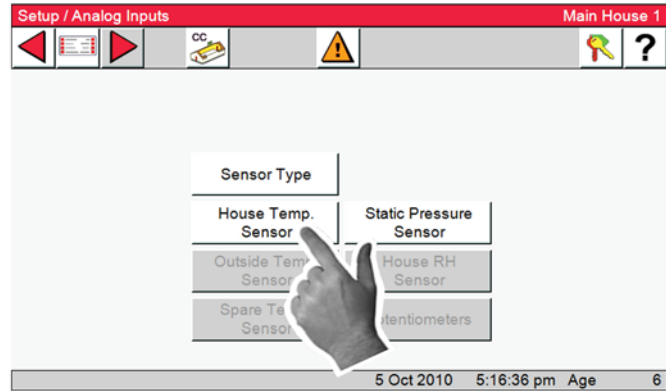

2. Factory assigned Sensor numbers

Temperature sensors 1-3 come from the factory pre-assigned. To assign the next sensor select the Add button and the next sensor will appear (See below right).

3. Adding Sensor assignments

Fill in the Board, Input, and backup by selecting from the dropdowns. Continue until all the temperature sensors have been assigned. If it is desired to skip a sensor and move to the next sensor in the list, select the - (not assigned) on the sensor that needs to be skipped and select the ADD button, next sensor will appear in the list.

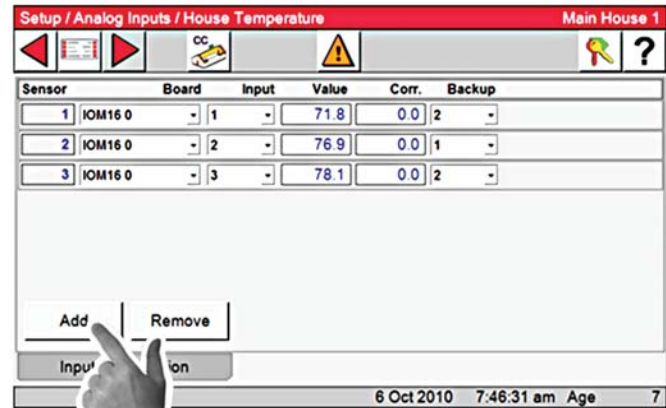

4. Board

The number of the Board the Sensor is connected. Board number 0 is the IOM16 Board. If the sensor is connected to an additional analog input board, then the Board number matches the address of the add on Board (see the installation section of this manual).

5. Input

This is the input number that the Sensor is connected to on the Board. On the IO Board the input number will be 1 thru 16. If the Sensor is connected to an additional Analog Input Board then the Input number will be 1-4.

6. Value

This is the current temperature reading.

7. Corr.

This is the amount of correction made when the sensor was calibrated. Calibration will be gone over later in the manual.

8. Backup

This is the sensor you want to be the backup if the sensor fails.

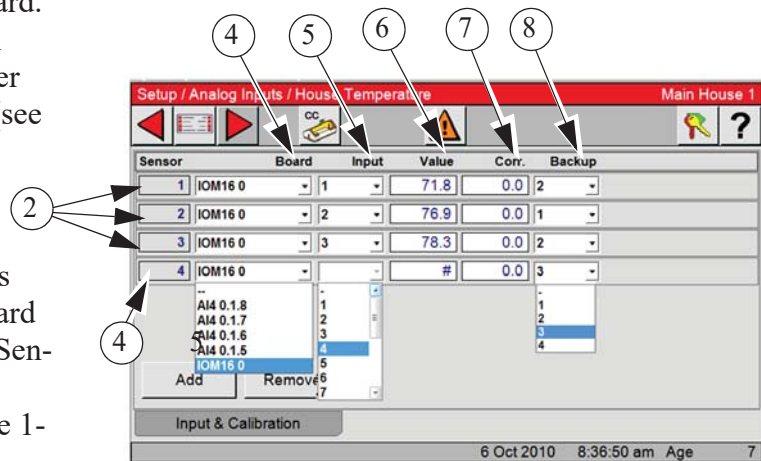

Select the Back button after all the House temperatures have been assigned.

Analog Inputs-Outside Temperature Sensor

1. Select the Outside Temp. Sensor button

In this screen the Outside sensor is assigned. Calibration is also done from this screen. Skip this Screen if no outside sensors are installed.

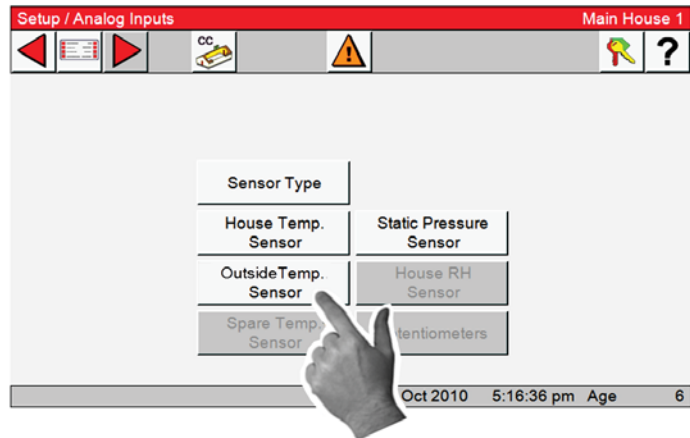

2. Adding Sensor Assignments

Fill in the Board and Input by selecting from the dropdowns.

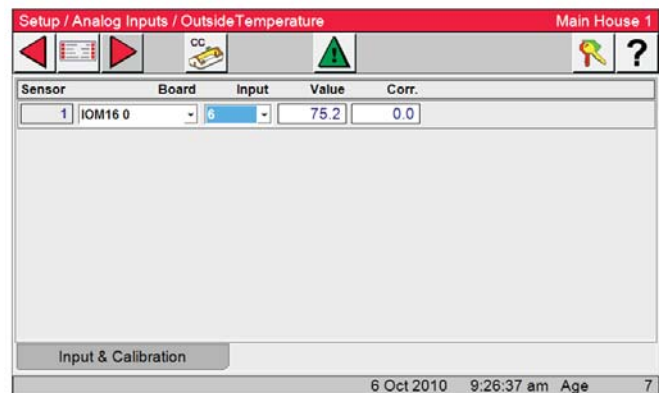

Select the Back button after the Outside temperature sensor has been assigned.

Analog Inputs-Static Pressure Sensors

1. Select the Static Pressure Sensor button

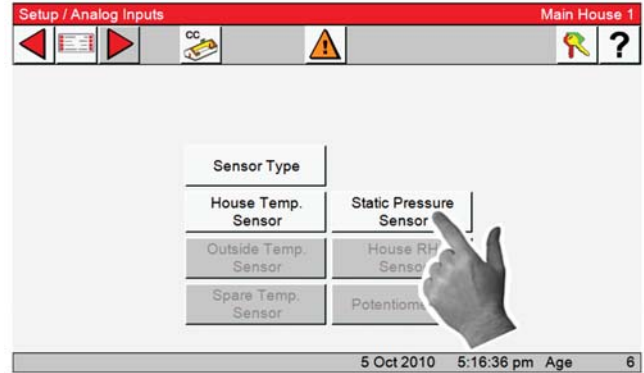

2. Assign Static Pressure input as you did for the House Temperature Sensors. Calibration is also done from this screen.

3. Select the Control Tab button

In this screen you set up the specifications for the Static Pressure Sensors

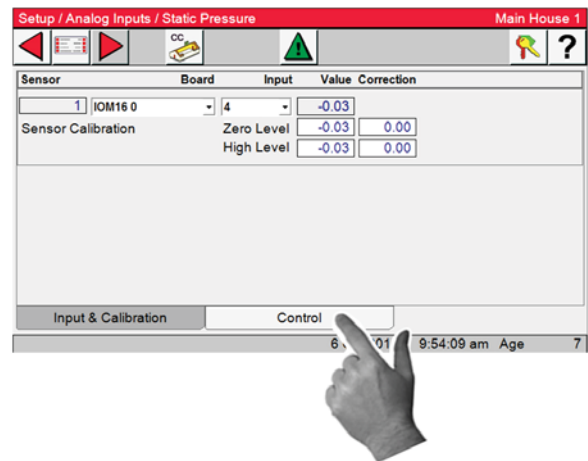

4. Current Safety Limit

Static Pressure Safety limit- Example: When the static pressure stays above 0.20 for a continuous minute, the Tunnel Curtain (if in Power Mode) and the Inlets (if in Tunnel Mode) will open until the static pressure reduces below 0.20. Once the problem is fixed and the static pressure reduces below 0.18, the Control returns to normal operation. The safety limit can be set from .18 to .27. This situation will always result in a High Pressure Alarm.

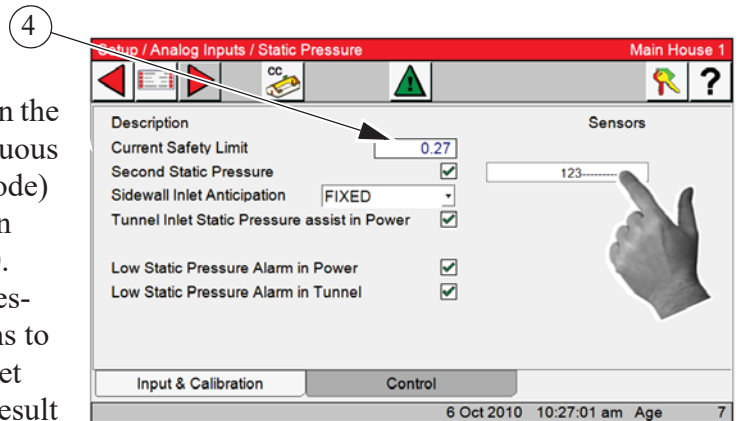

5. Second Static Pressure

Selecting this feature a second level of Power Mode static pressure can be chosen. The Temperature Sensor(s), (Inside Only), that measure that temperature is defined in this screen. Select the sensor edit field and a sensor assignment window will be displayed.

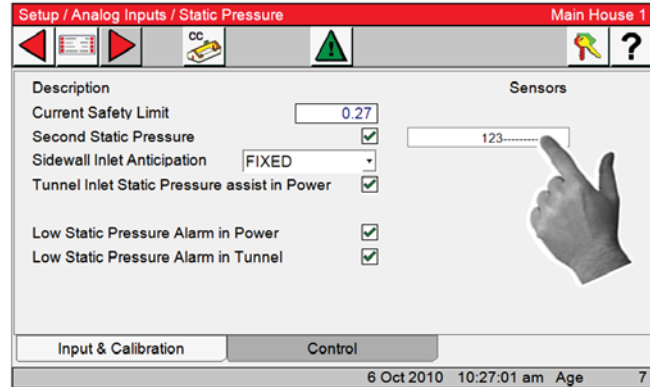

6. Select/Deselect sensor check box

Select or deselect the sensor check box to choose the sensor or sensors you want to use. Select OK to save. The temperature at which the second static pressure takes over is entered in Output and Temperature screen.

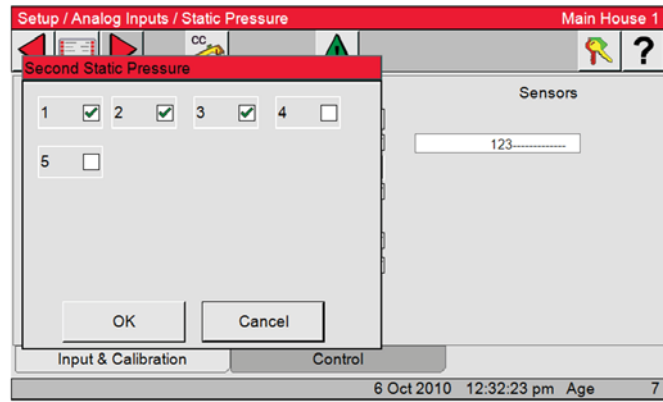

8. Tunnel Inlet Static Pressure assist in Power

If in the Power Mode, there is inadequate inlet area to keep the static pressure within the high control limits, the Tunnel Curtain will open to give additional air inlet area. The Inlets are given continuous open signals as the Tunnel Curtain takes over the responsibility of controlling the static pressure. The static pressure has to be above the high Static Pressure Control limit continuously for one minute with 3 or more Fans running for this to happen. Responsibility for Static Pressure Control is passed back to the Inlets as soon as there are fewer than 3 Fans running or the Tunnel Curtain cannot bring the static pressure back into the control range (while closing) from the low side. The static pressure has to be below the low Static Pressure Control limit continuously for one minute for this to happen.

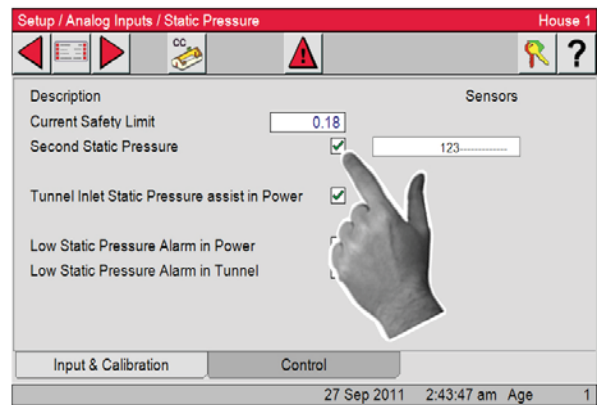

Select the Back button twice after the Static pressure has been assigned and Control screen is completed

Analog Inputs-Relative Humidity Sensor

1. House Relative humidity Sensor

From the Setup/Analog Input screen select House RH sensor Button.

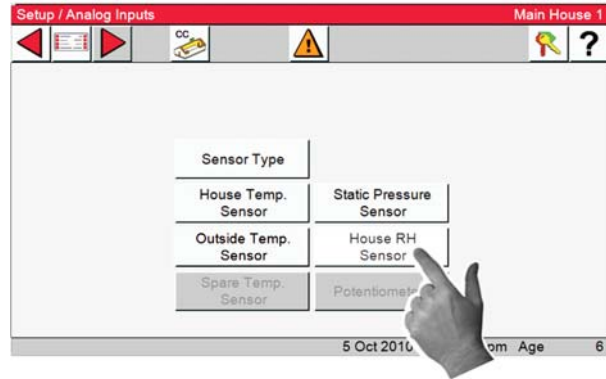

2. Assign the House RH sensor input as you did the House Sensors. Calibration is also done from this screen. See next manual section "Calibrating Analog Inputs".

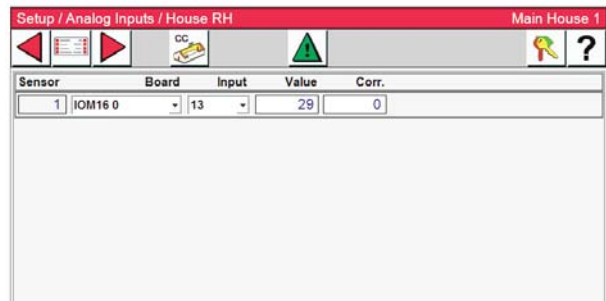

3. Select the Control tab.

4. Select the RH Influence On Minimum Ventilation box if you want the min/vent timer to be influenced by the RH.

5. The Minimum Ventilation timer will be adjusted based on house RH when the temperature is between set temperature and the Min-Vent fan's ON temperature. The Control will adjust the amount of ON time between the Min Ventilation value and the Max value. The OFF time will be adjusted by the same amount of time that the ON is adjusted, thus keeping the total cycle time constant. The temperature is checked 30 seconds before the beginning of the ON time cycle of the Minimum Ventilation Timer. This is in addition to any time added by Ventilation Timer Ramping.

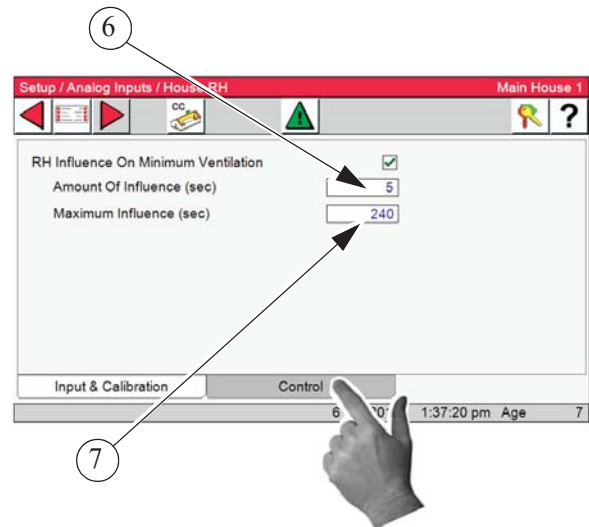

6. **Amount Of Influence (sec)**- is the amount of decrease or increase time pre movement.

7. **Maximum Influence(sec)**- is the maximum amount of RH timer influence you need.

Once the fans' temperature sensor(s) reach the fans' ON temperature, the fan will turn on and run continuously until the fans' OFF temperature is reached.

Once the fans' temperature sensor(s) reach the fans' ON temperature, the fan will turn on and run con-

Analog Inputs-Bird Scale

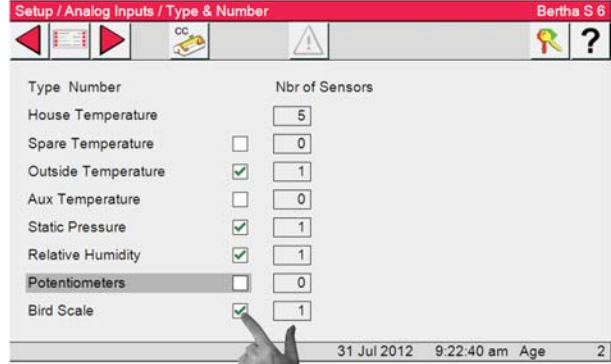
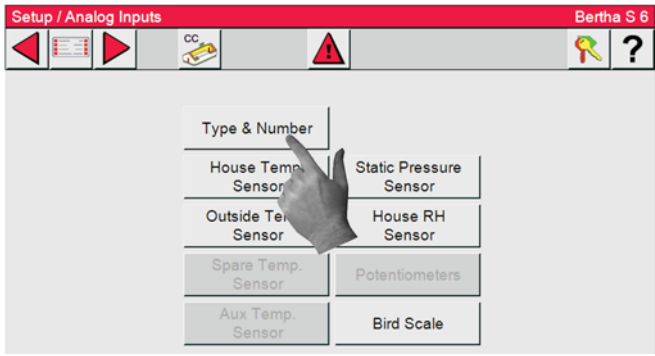

1. From the Setup/Analog Input screen select Type & Number.

2. Put a Check in the Bird Scale Box.

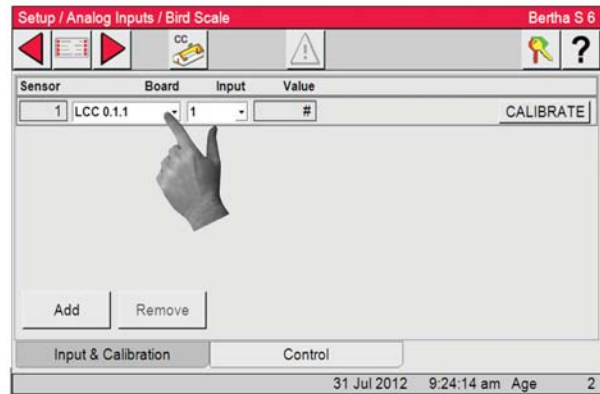
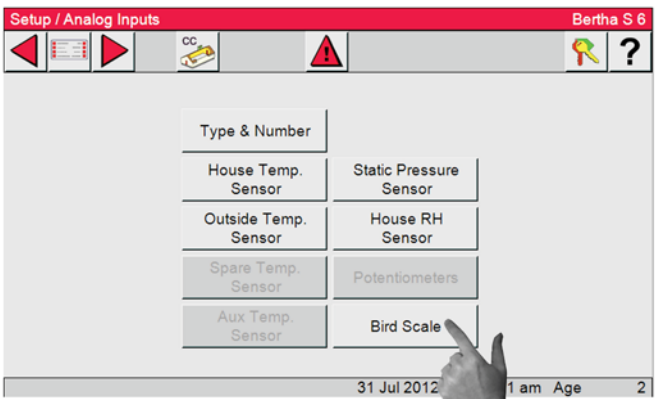

3. Select the Back  Button and then select

4. Select the Board number from the drop down.

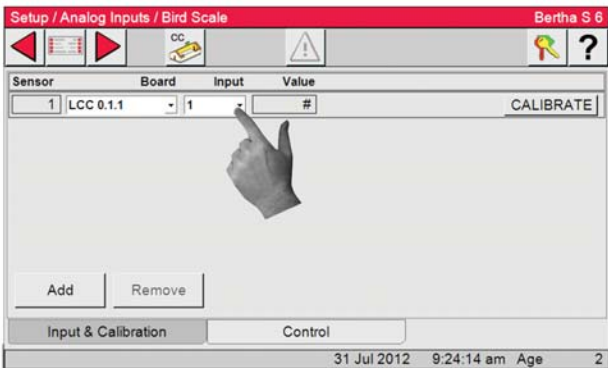

5. Select the Input from the drop down. Select 1.

Analog Input Calibration

The re-calibration section of this screen should not need to be used at initial installation and start-up of the Control unless natural ventilation is used. If natural ventilation is being used, then the Potentiometers will need to be calibrated at this time. If it is felt that one of the Inputs needs to be re-calibrated perform the following steps...

Temperature Sensor Calibration

1. To re-calibrate the Temperature Sensors, first obtain a digital thermometer that has a readout of at least $\pm 1^\circ$. Do not use a temperature gun. A temperature gun measures an object's temperature, not air temperatures.

2. Place the digital thermometer next to the Temperature Sensor that is being re-calibrated. Take the reading from the digital thermometer and enter that number under the Value column of the Sensor being calibrated.

3. The Correction column is used only for service information and to return the Control to the factory settings. The settings should be reset to factory whenever a re-calibrated Temperature Sensor is replaced. To return to factory settings change the number under the correction column by one digit. This will cause the correction to automatically zero out and return to factory setting.

Sensor	Board	Input	Value	Corr.	Backup
1	IOM16 0	1	89.2	0.0	2
2	IOM16 0	2	85.9	0.0	1
3	IOM16 0	3	89.2	0.0	2
4	IOM16 0	5	92.2	0.0	3
5	IOM16 0	6	90.0	0.0	4

All Temperature Sensors are calibrated the same way. (Outside, Spare and Aux temperature sensors)

Relative Humidity Sensor Calibration

1. To re calibrate the Relative Humidity Sensor first obtain a sling psychrometer or another humidity measuring device.

2. Operate the psychrometer in the same area that the Relative Humidity Sensor is installed. Take the reading on the psychrometer and compare it to the reading on the Setup/Analog Inputs/ House RH Screen. If the readings do not match, then change the reading under the Value column to match the reading of the psychrometer.

3. The correction column is to be used for service information and for returning to factory settings only.

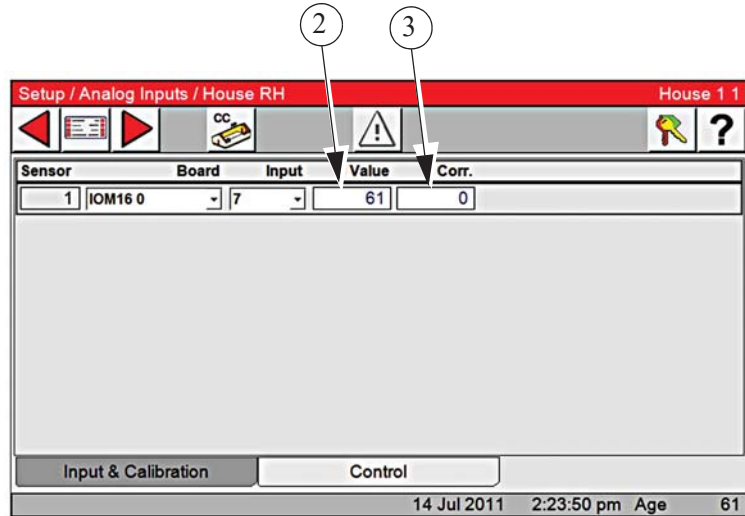

Static Pressure Sensor Calibration

1. To re-calibrate the Static Pressure Sensor first obtain a manometer or other static pressure measuring device. Then disconnect both hoses from the Static Pressure Sensor.

2. Go to Setup/Analog Inputs/Static Pressure screen and look at the Pressure reading in the Zero Level value box. If the reading is not zero then change the zero level value pressure to read zero. The zero level has now been calibrated.

3. To calibrate the high level, first make sure that the Manometer has been installed in the house and reconnect the hoses to the Static Pressure

Sensor. Open the Inlets slightly and turn on enough Fans to create a static pressure of at least 0.15 inches of w.c. at the Manometer. Compare the Manometer reading to the reading on the High Level line on the Control. If the readings do not match, edit the pressure reading on the High Level value box to match the reading of the Manometer. As with the Temperature Sensors, the Correction column of the static pressure calibration is used for service, and to return the Control to factory settings only. This completes the re-calibration of the static pressure Sensor.

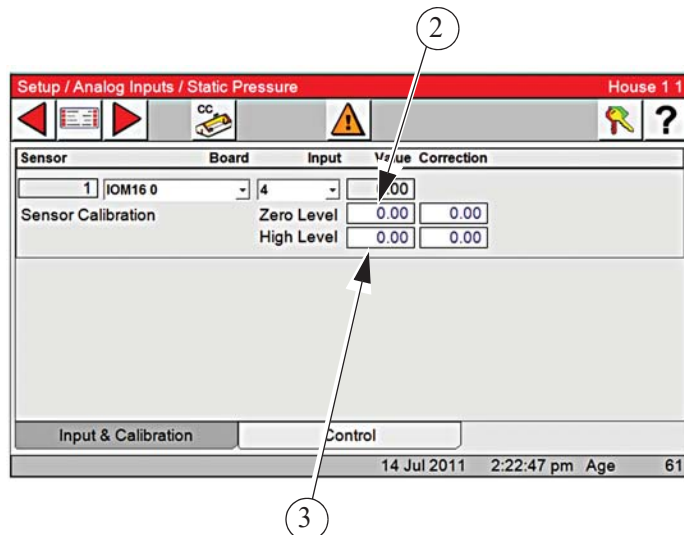

Bird Scale Calibration

1. Go to the Setup/Analog Inputs/Bird Scale Screen and Select Calibrate. (Platform should be hanging from the Load Cell)

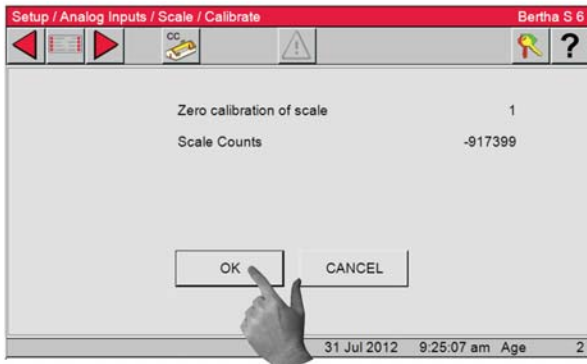
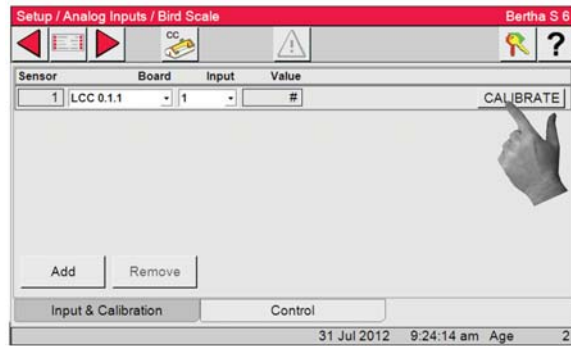

2. With no weight on the Platform select the OK Button. If there is no error then continue.

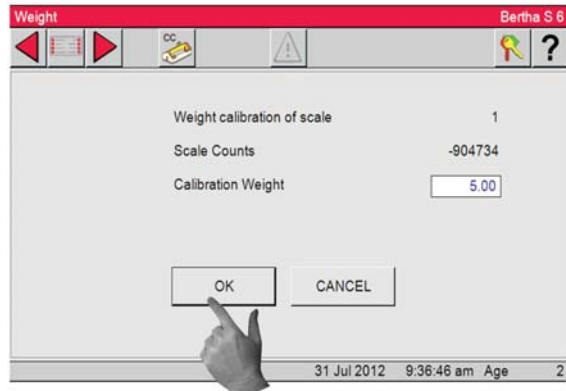

3. Place a 5.00 lb. weight on the Platform. In the "Calibration Weight Box" enter 5.00. Click the Ok Button. If no error then the calibration is done.

Digital Inputs

The Digital Input Screens are very similar to the Analog Input screens and setup the same way. In these screens the Control is told what digital inputs (Water Meters, Feed Scales, Airspeed Sensor, Low Water Pressure Switch, Flush Feed Back, Auger Run Time Alarm, etc.) are connected to the Control and where. All digital or pulsed inputs that are connected to the Control must be assigned a board number and an Input number. It is highly recommended that the Input Decal located inside the main box of the Control be completed before entering information in this screen.

Board- This is the number of the board where the water meter or other digital input device is connected. Board number 0 is the I/O Board. If the sensor is connected to an additional digital input board, then the board number matches the address of the add on board (see the installation section of this manual).

Input- This is Input number that the water meter or other digital input device is connected to on the board. For the I/O Board the input number will be 1 thru 8. If the sensor is connected to an additional analog input board then the input number will be 1-4.

Name- A name can be entered for the Water meter, feed scale, and auxiliary digital inputs using the alphanumeric keypad. The name entered here will appear in the Auxiliary Data and History screens.

Select Add and the next Sensor will appear in the list.

Select Remove and the last Sensor in the list will be deleted.

1. Select the Main menu button.  Select the Setup but-

ton  from the Main Menu screen. Finally,

select the Digital inputs Button.



Type and Number

2. Select the Type & Number button.

3. Select the Digital inputs you have connected to the Chore-Tronic's 3.

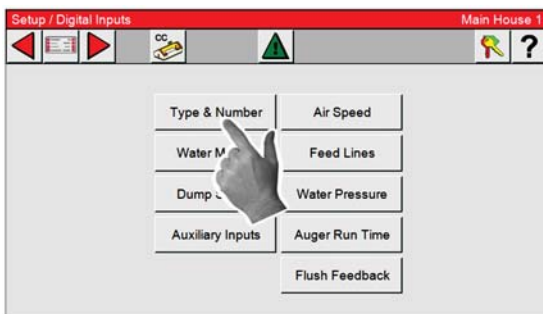

Digital Inputs

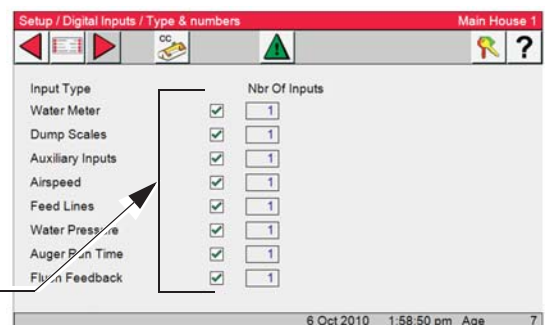

Water Meter

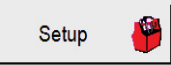
1. Select the Main menu button.  Select the Setup button  from the Main Menu screen. Finally, select the Digital inputs Button.

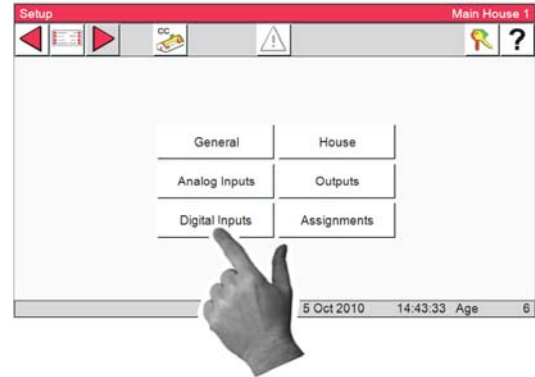

2. Select the **Water Meters** button.

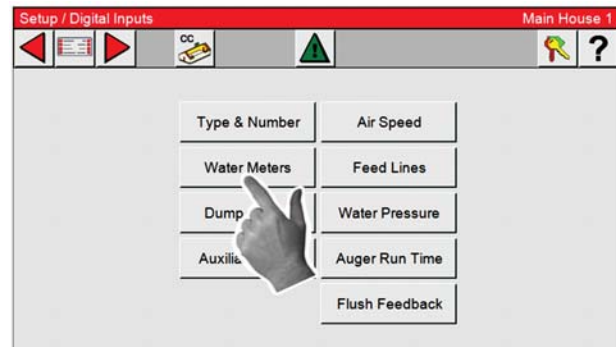

3. Enter all Drinker/Water Meters that are connected to the CT3 here. A Drinker Water Meter is a Water Meter that is monitoring the water being used by drinker water lines or the entire house (1 meter for both drinker lines and Cool Pads). If a Water Meter is assigned an input here, its daily usage will be added to the total amount of consumed water in the management screen. When a Water Meter or other digital input is assigned to a board and an input on that board, to add the next Water Meter or digital input select the ADD button and Meter #2 will appear. If it is desired to skip a Meter or other digital input and move to the next digital input in the list, enter (not assigned) for the input that needs to be skipped. it is desired to skip a Meter or other digital input and move to the next digital input in the list, enter (not assigned) for the input that needs to be skipped.

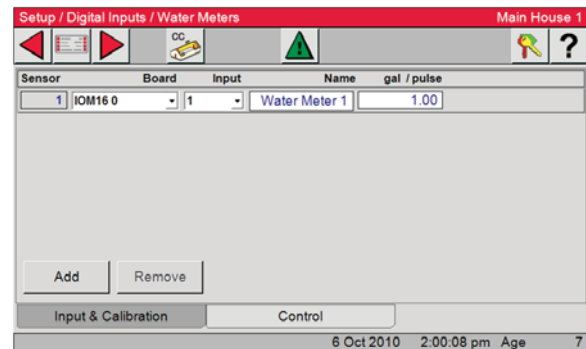

4. Select the **Control** tab

Water Flow Rate Alarm- Put a check in the box if you want an alarm when flow rate is too high. The parameters are setup in the Alarm screen under the Production tab.

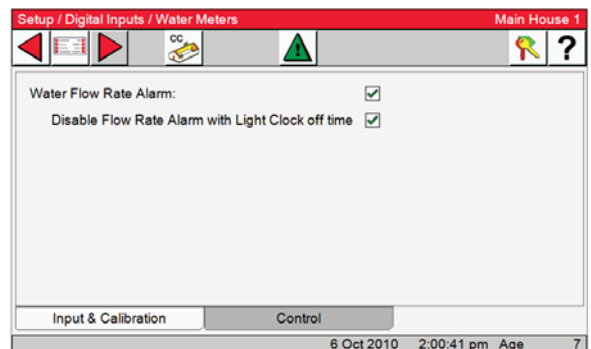

Dump Scale

1. Select the **Dump Scale** Button.
 All feed scales that are connected to the Control needs the input it is connected to assigned here. All feed scales that are assigned inputs here will have their daily usage added to the total amount of feed consumed in the management screen.

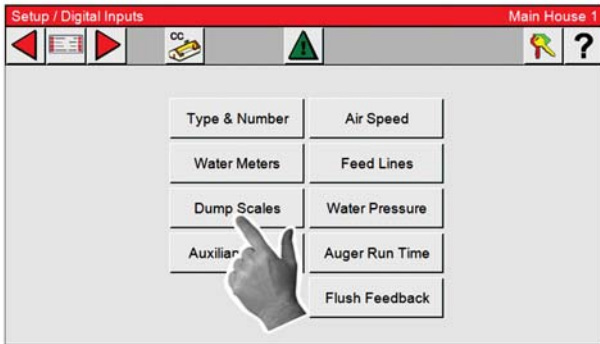

2. Assign an input to each of the feed scales connected to the Control here. Each Input assigned here will have its daily usage added to the total amount of feed consumed in the management screen.

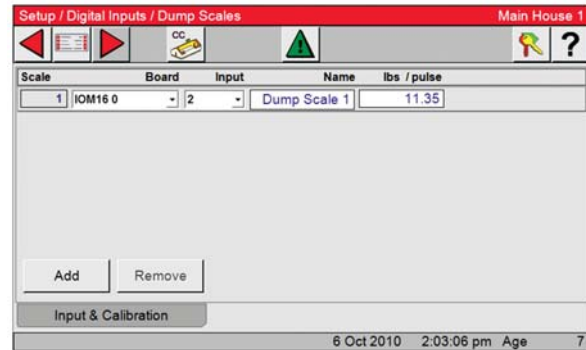

Auxiliary Inputs

1. Press Auxiliary Input button
 Many different types of auxiliary digital Inputs can be used with the Ct3.

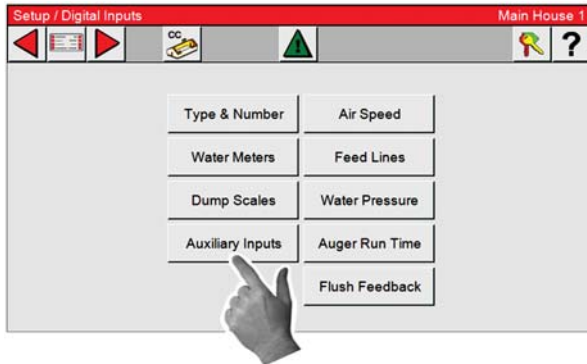

2. Types of auxiliary Inputs include non-drinker water meters (water meters attached to evaporative cool pads, etc.), pulsed output electric meters, pulsed output gas meters, etc. Each inputs usage will be monitored separately and will not be added to any total usage.

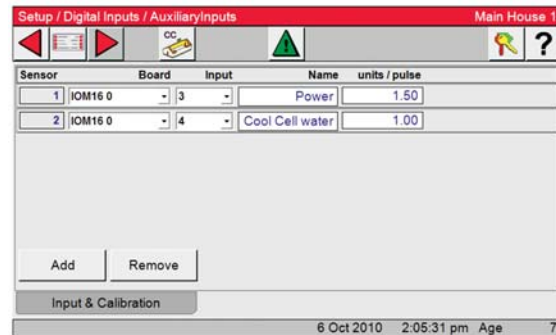

Airspeed Sensor

1. Press the Air Speed button.

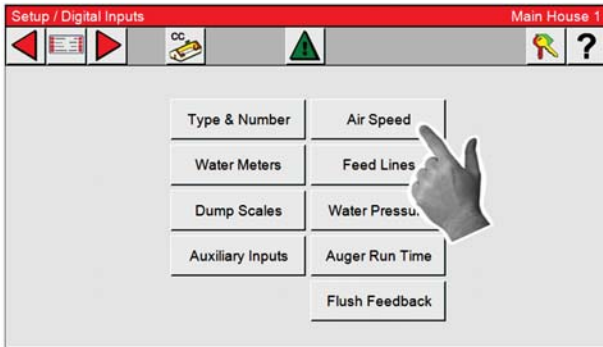

2. Enter the board and input numbers for the Air speed meter. The parameters are setup in the Alarm screen under the Environment tab.

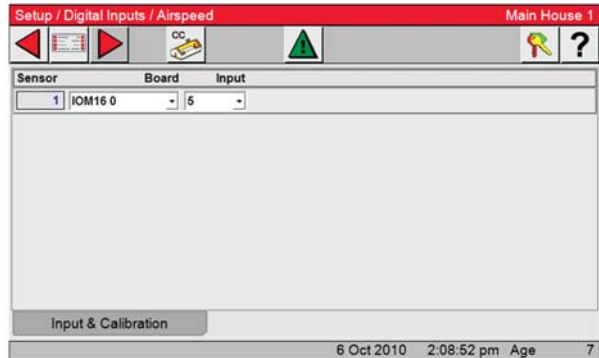

Feed Lines

1. Press the Feed Lines button.

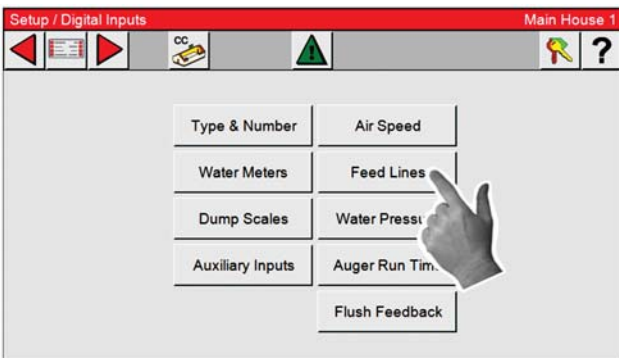

2. Enter the board and input of each Feed Line connected to the Control. Feed Line run times will be generated from these inputs.

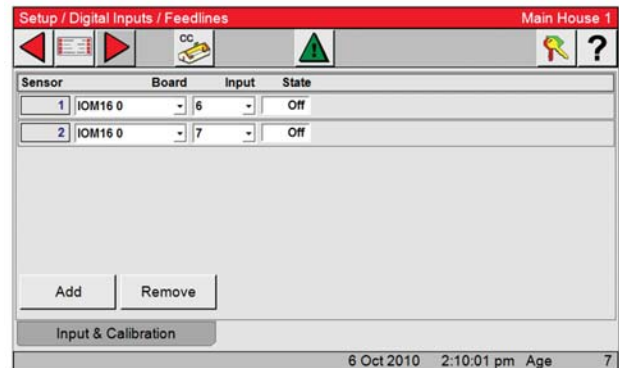

Water Pressure

1. Press the Water Pressure button.

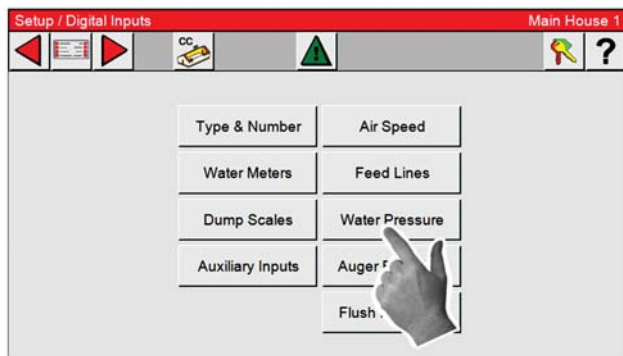

2. Enter the board and input for the Water pressure switch. Switch must open with low pressure. The parameters are setup in the Alarm screen under the Production tab.

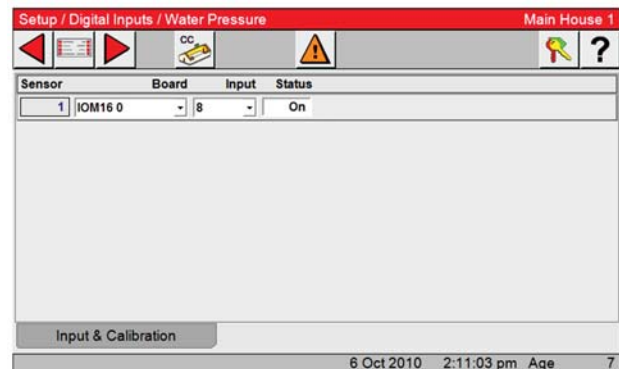

Auger Run Time

1. Press the Auger Run Time button.

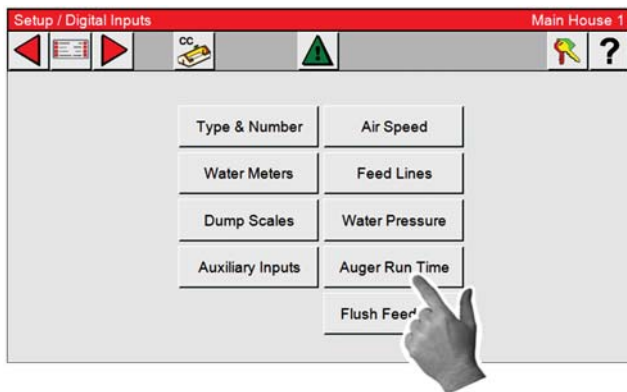

2. Enter the board and input of the Auger run time relay. The parameters are setup in the Alarm screen under the Production tab.

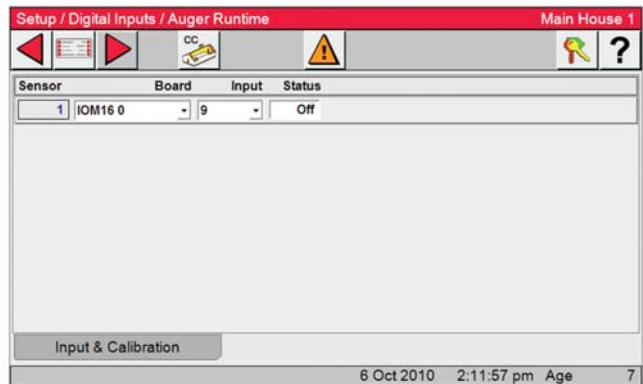

Flush Feedback

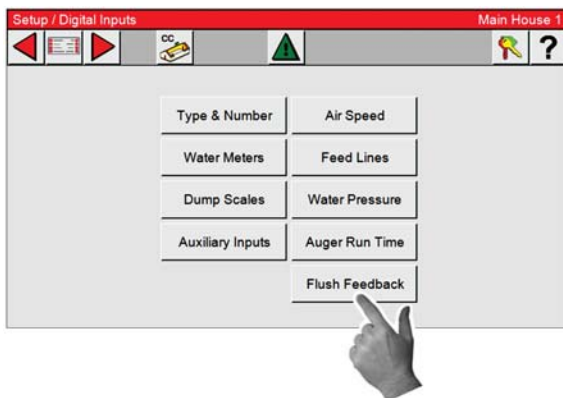

1. Press the Flush Feedback button.

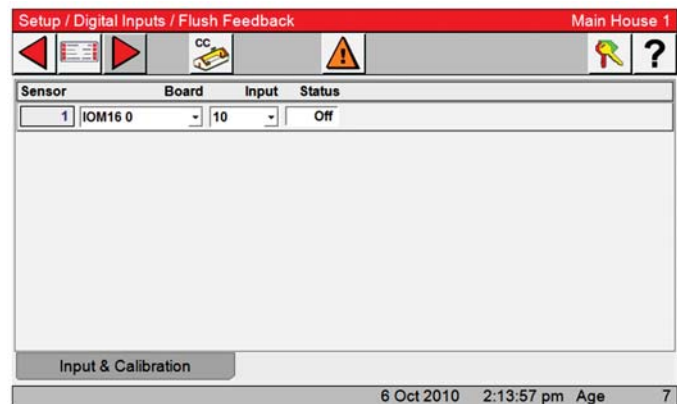

2. Enter the board and input of the PDS flush feedback. The parameters are setup in the Alarm screen under the Production tab.



Setup House

1. Select the Main menu button.  Select the Setup button  from the Main Menu screen. Finally, select the **House** Button.

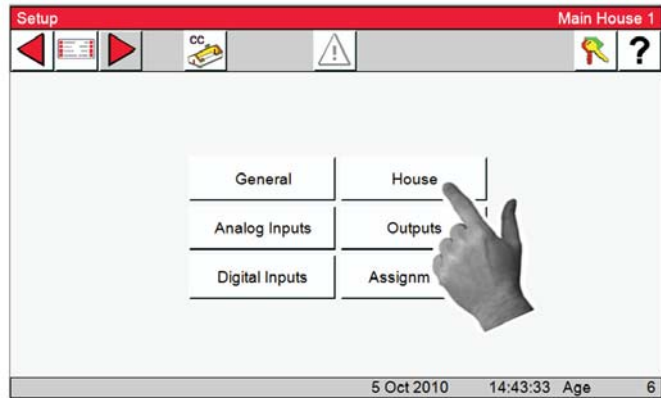

2. In this Screen you set what type of ventilation is being used in the House.

3. **Temp. Influence on Minimum Ventilation.** Select this box if you want the Min. Vent Timer to ramp up & down based on temperature. See **explanation and example below.**

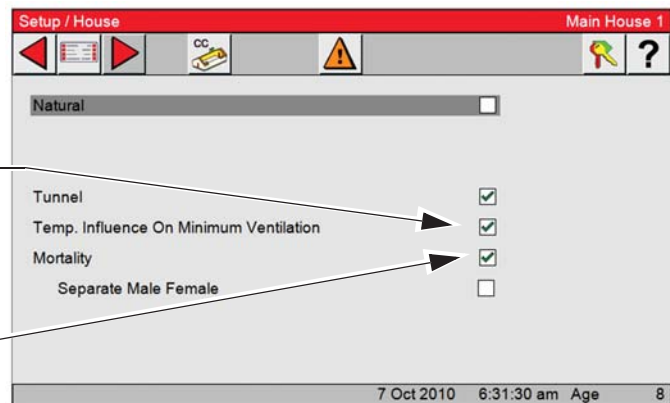

4. **Mortality** Select this box if you want to keep track of the Mortality. To separate male and female select Separate Male Female.

Ventilation timer ramping- If the sensor(s) that are assigned to the Minimum Ventilation fan(s) temperature is at or below set temperature then the fans will use the ON and OFF times that are listed for the Minimum Ventilation Timer. If the sensor (s) assigned to the Ventilation Time Ramping temperature is between set temperature and the fans' ON temperature the control will adjust the amount of ON time between the Min Ventilation value and the Max value. The OFF time will be adjusted by the same amount of time that the ON is adjusted, thus keeping the total cycle time constant. The temperature is checked 30 seconds before the beginning of the ON time cycle of the Minimum Ventilation Timer. Once the fans' temperature sensor(s) reach the fans' ON temperature, the fan will turn on and run continuously until the fans' OFF temperature is reached.

Example:

The set temperature is 70.0°F and the fans assigned to the Min Vent timer ON temperature is 72.0°F. The Minimum Ventilation Timer values are 30 seconds ON time and 270 seconds OFF time. The maximum ON time is 210 seconds. If the sensor(s) assigned to the Ventilation Time Ramping temperature is 71.0°F at the beginning of the anticipation cycle, then the fans will have an ON time of 125 seconds and an OFF time of 175 seconds.

Output Assignments

1. Select the Main menu button.  Select the Setup button  from the Main Menu screen.

2. Press the Outputs button
Some of the buttons on this screen may be grayed out at this point of the setup.

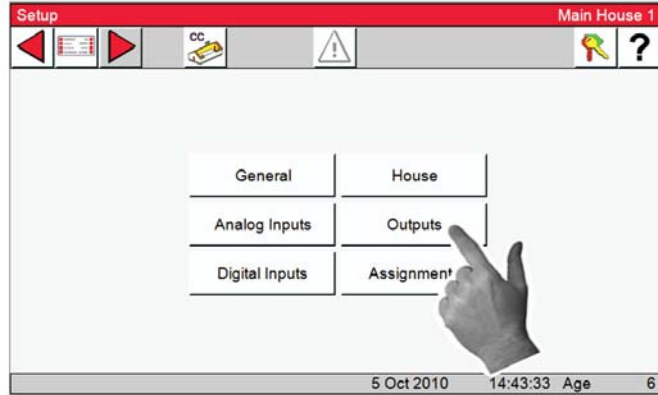

Outputs-Equipped/Numbers

1. Press the Outputs button
Some of the buttons on this screen may be grayed out at this point of the setup.

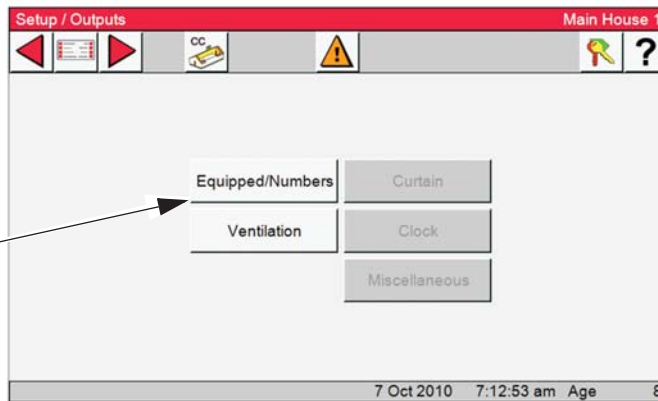

2. Press the Equipped/Numbers button
Some of the buttons on this screen may be grayed out at this point of the setup.

3. In this screen the Control is told what equipment it is connected to: Fans, Curtains, Inlets, clock type and backup relays. The Nbr. Of Outputs column is read only and will be filled in as Setup continues.

Output Type	Nbr of Outputs	
Cool Pad	<input checked="" type="checkbox"/> 1	Combined Inlets <input type="checkbox"/> 0
Cool	<input checked="" type="checkbox"/> 1	Sidewall Inlets <input checked="" type="checkbox"/> 1
Tunnel Fans	<input checked="" type="checkbox"/> 1	Ceiling Inlets <input checked="" type="checkbox"/> 1
Stir Fans	<input checked="" type="checkbox"/> 1	Main Curtains <input type="checkbox"/> 0
Exhaust Fans	<input checked="" type="checkbox"/> 1	Tunnel Inlets <input checked="" type="checkbox"/> 1
Variable Fans	<input checked="" type="checkbox"/> 1	Light Clocks <input checked="" type="checkbox"/> 1
Heat Zones	<input checked="" type="checkbox"/> 1	Water Clocks <input type="checkbox"/> 0
Spare Temp <input type="checkbox"/> 0		Feed Clocks <input checked="" type="checkbox"/> 1
		Spare Clocks <input checked="" type="checkbox"/> 1
		Feeder Window <input type="checkbox"/> 0
		Backup <input checked="" type="checkbox"/> 1

4. Select the Back  button to return to the Setup/Output screen.

Outputs-Ventilation

Notice that all the buttons are now active.

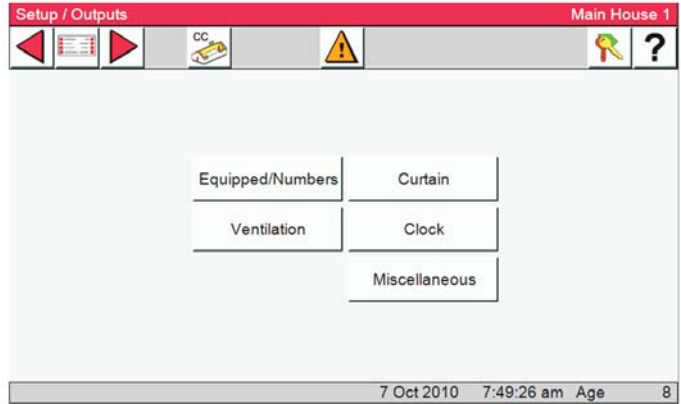

Ventilation-Tunnel Fans

1. Select the Ventilation button.

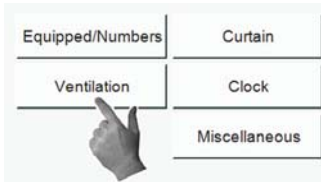

2. Every Output needs to have a relay, mode of operation (Power, Natural, Tunnel, or combinations of the three), and temperature sensor(s) assigned to it. Initially when pressing the Cool, Exhaust Fan, Stir Fan, Tunnel Fan and Heat Zone buttons only one output will appear.

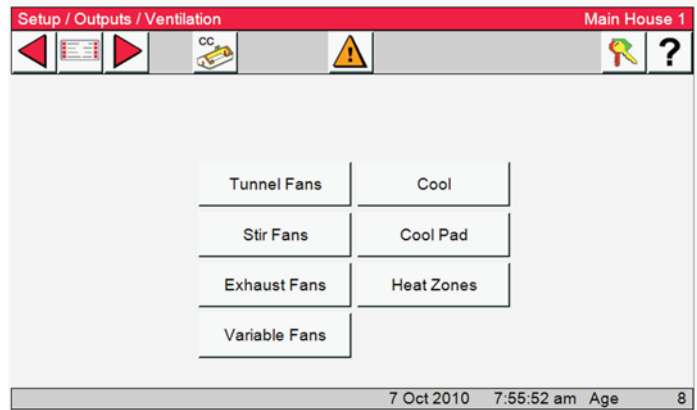

3. Select the Tunnel Fans button.

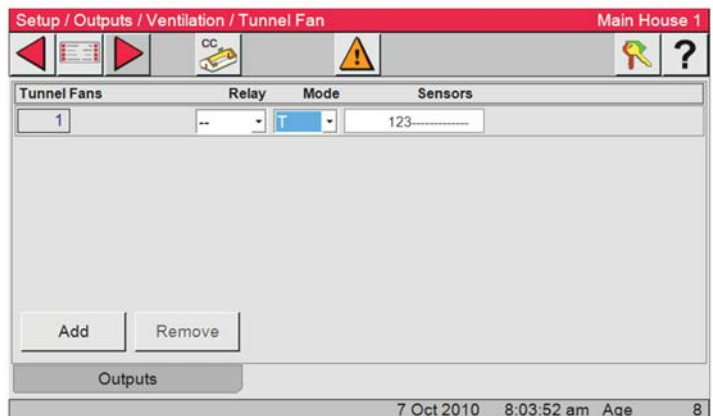
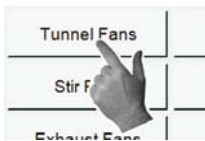

Continue to next page.....

Relay assignment Decal
(inside Relay Box)

Relay # Relay Assigned To...

Refer to the Relay Assignment Decal (Inside the Relay Box) to assign relays to each of the fans.

1		29
2		30
3	Tunnel Fan 1	31
4		32
5		33
6		34

2. Select the Relay dropdown to assign the proper Relay to each Tunnel Fan.

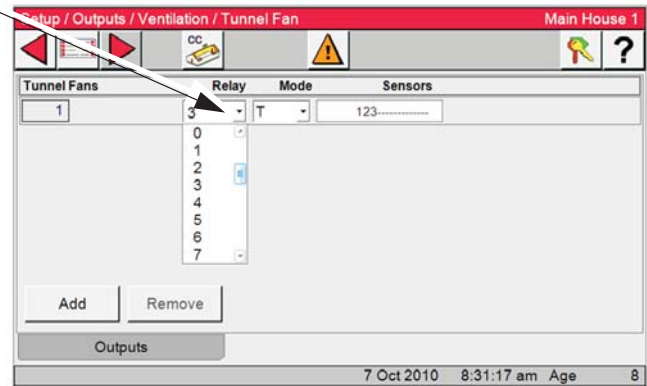

3. Select the Mode dropdown
A list of available Modes will appear. Select the mode (modes) that the Fan needs to operate in.

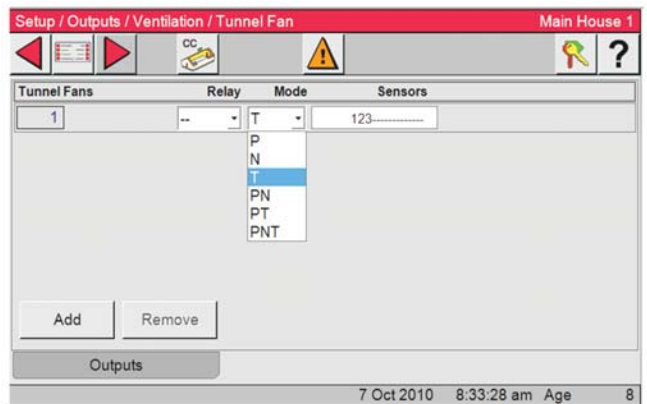

4. In the Sensors column select the sensor/sensors to be assigned to the Fan. Touch the sensor window and a select sensor box will appear with the available sensors. Select or deselect the sensors to come up with the sensor or sensors to control the Fan. Select OK to save.

This completes Tunnel Fan 1.

5. To assign additional Tunnel Fans, select the Add button. The next fan will appear. Follow the same steps as used for Tunnel Fan 1 to assign the relay, mode, and sensor assignments.

Using the same steps continue to add Tunnel fans until finished.

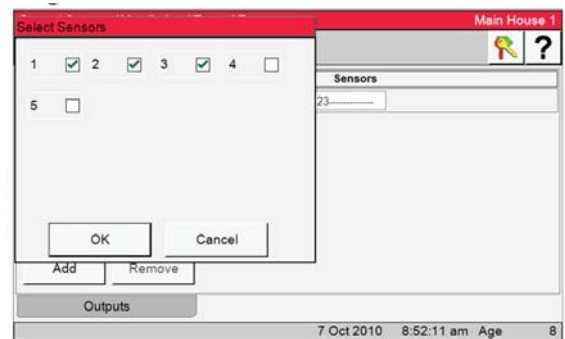

Note: Only house sensors can be assigned to outputs.

Ventilation-Stir Fans

1. Select the Ventilation button.

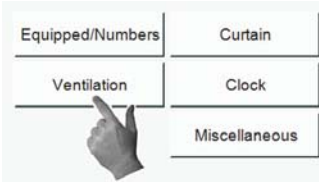

2. Select the Stir Fans button.

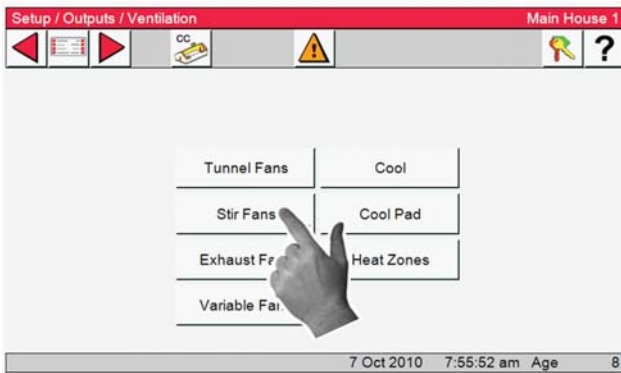

3. Assign Relays, Sensors and Mode values to the Stir Fans just as you did for Tunnel Fans. (See previous page)

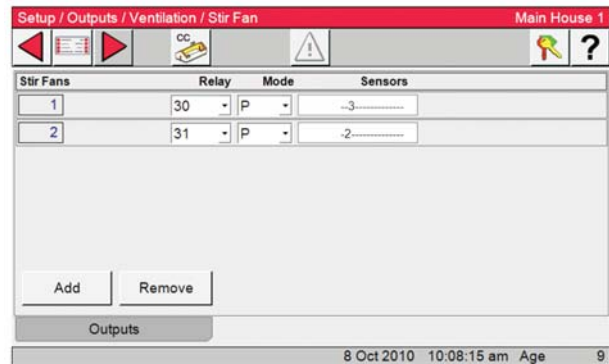

Ventilation-Exhaust Fans

1. Select the Ventilation button.

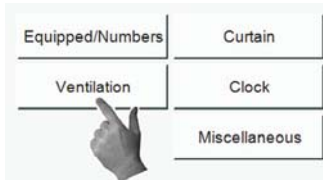

2. Select the Exhaust Fans button.

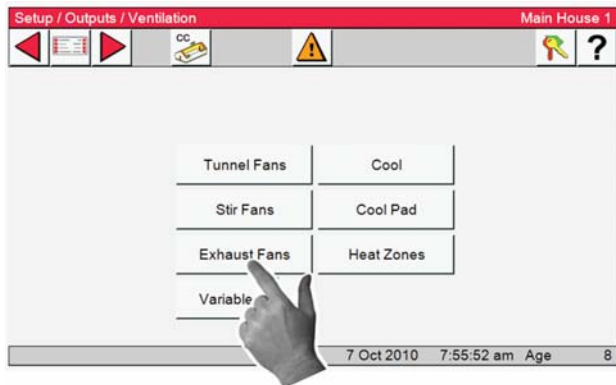

3. Assign Relays, Sensors and Mode values to the Exhaust Fans just as you did for Tunnel Fans. (See Tunnel Fans previous)

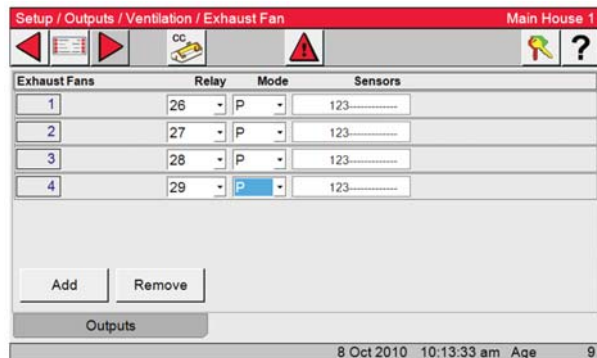

Ventilation-Variable Fans

Note: The Var. Speed output is a 0-10 or 10-0 vdc output on the IO board not the Relay box.

1. Select the Ventilation button.

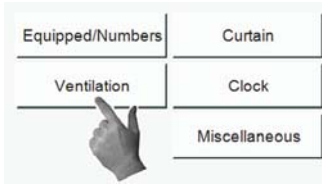

2. Select the Variable Fans button.

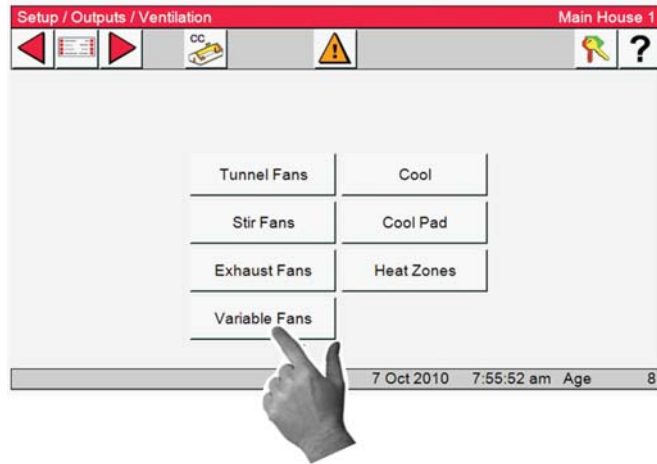

3. Assign Sensors and Mode values to the Variable Speed Fans.

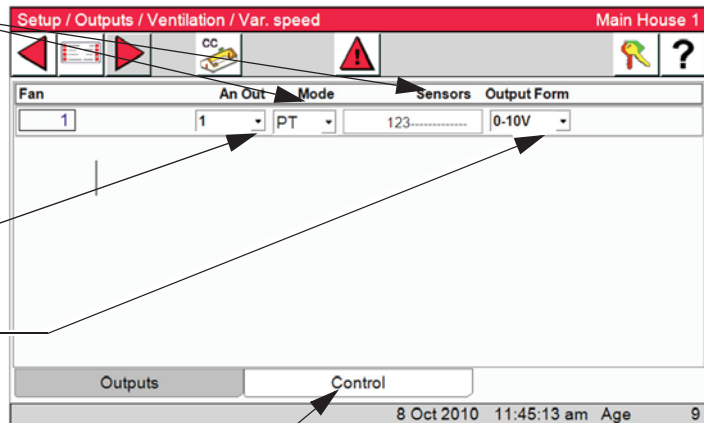

4. Assign the analog output from the dropdown.

5. Assign the Output Form- You will need to know the input range of the Frequency drive before choosing 0-10 or 10-0 vdc from the dropdown.

5. Assign the Output Form- You will need to know the input range of the Frequency drive before choosing 0-10 or 10-0 vdc from the dropdown.

5. Press the Control Tab

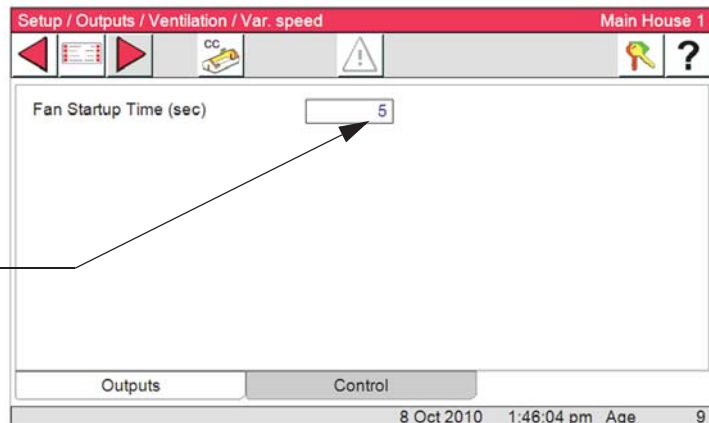

6. Enter the amount of startup time needed to open the fan shutters.

Example: If 5 is entered, the Variable speed fan will run at full speed for 5 sec. at startup, then return to the current speed.

Ventilation-Cool

The Cool outputs can be used for cool pads, fogger pads and or inside foggers. The Cool output can be setup to be on/off based the temperature setting in the Output & Temperature. A timer can be assigned to the Cool output. If a timer is assigned, at the on temperature the output will start timing on/off based on the timer setting and will not run constant.

Sixteen Cool outputs can be assigned up to four relays per Cool output.

1. Select the Ventilation button.

2. Select the Cool button to assign the Cool outputs..

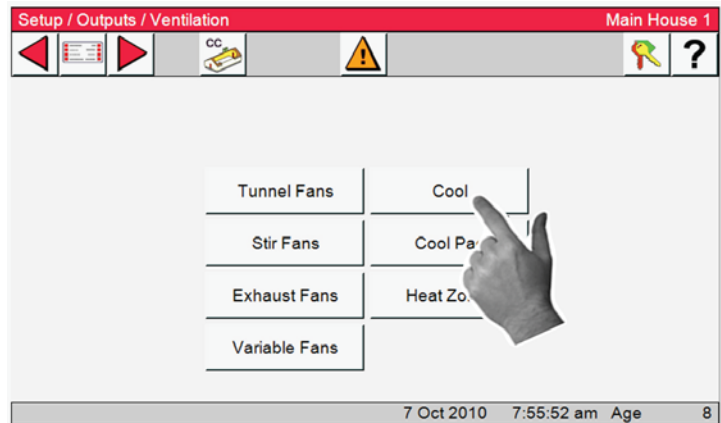
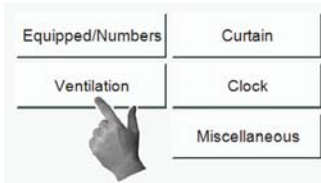

3. Assign Relays, Sensors and Mode values to each Cool item.

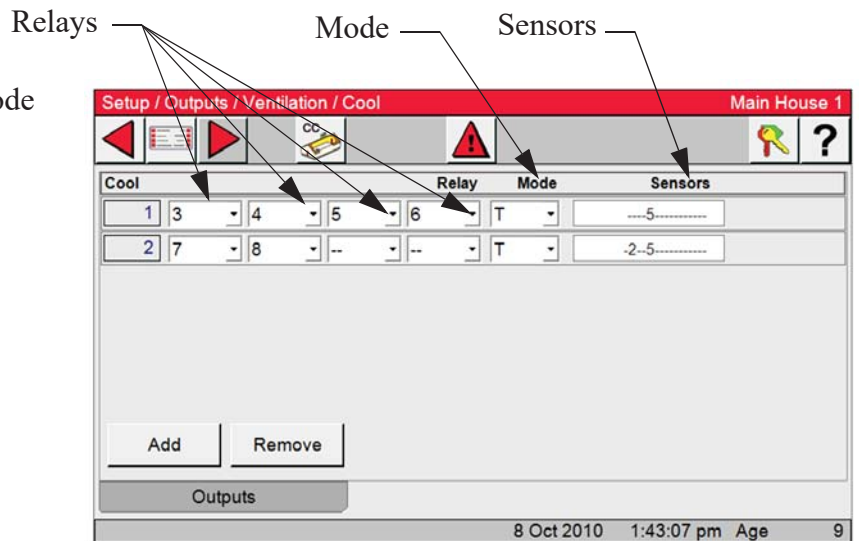

Ventilation-Cool Pad

The COOL PAD output is very different from a COOL output. It is not intended that the COOL PAD output and the COOL output would be used together, but it is possible. Both outputs are there to give the user the choice on which type of output to use. The COOL PAD's relay operation is designed to begin the cooling caused by the cooling pad by first adding 5 seconds of water to the pad every 5 minutes. If the temperature is still with the "Cool Pad Range" after 4 doses of 5 seconds of water, the amount of water added to the pad every 5 minutes remains the same. If the temperature is above or below the temperature limits of the "Cool Pad Range", the amount of water "on" time each 5 minutes is increased or decreased 5 seconds. With the default settings the temperature is only checked every 20 minutes. If it is desired for the temperature to be checked more often if a sudden large temperature change occurs, then values should be entered in the "Extra aggressive if" lines (Items and , Figure). For example, The Control is set to be extra aggressive if 3.0 degrees above the upper limit of the COOL PAD range. Whenever the temperature is more than 3.0 degrees above the upper limit of the COOL PAD range the Control will begin checking the temperature every 5 minutes (every repetition rate) instead of every 20 minutes (every 4 repetition rates) until the temperature returns to less than 3.0 degrees above the COOL PAD range. The default extra aggressive settings are 3 degree.

1. Select the Ventilation button.

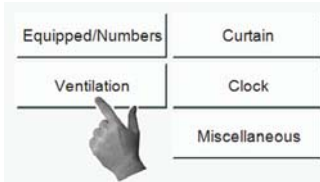

2. Select the Cool Pad button to assign the Cool Pad outputs.

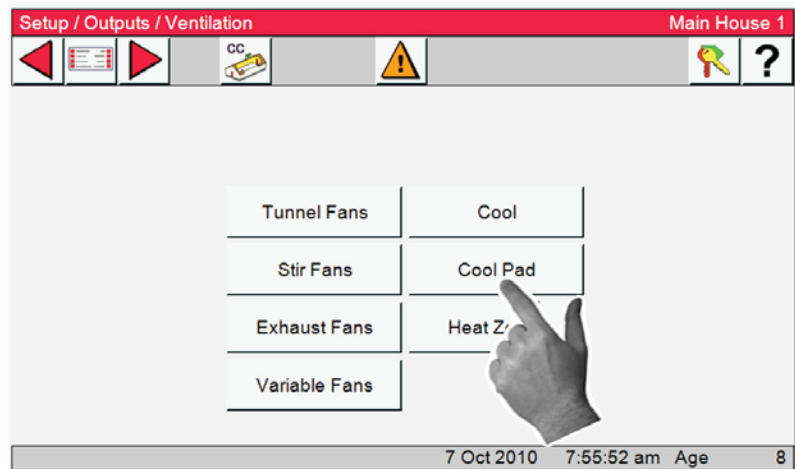

3. Assign a Relay, Sensors and a Mode value to the Cool Pads.

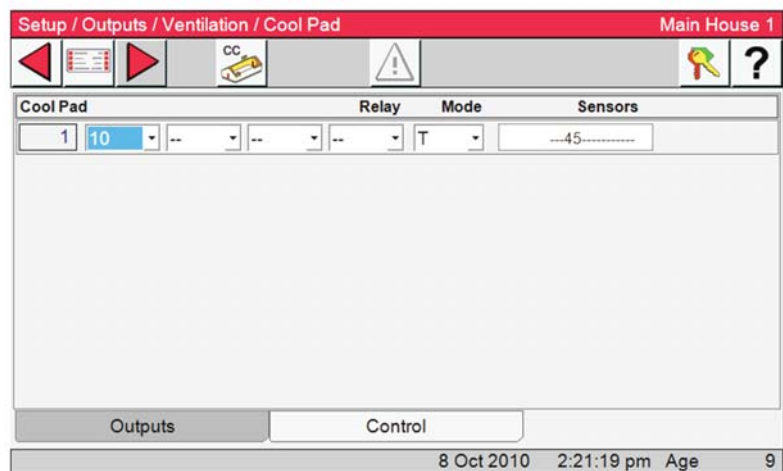

On a very hot day it would be possible for the water to be running continuously and the temperature to be in the "Cool Pad Range". A more moderate day might result in the water running a very small amount of time in order to keep the temperature within the "Cool Pad Range". Similarly, on a low humidity day the amount of water required to keep the temperature within the "Cool Pad Range" would be less than for a high humidity day. The Control will adjust the water as required to keep the temperature in the "Cool Pad Range". If it is desired to not allow the water to run continuously, then the Max water allowed (Item 4, Below) value should be changed so that it is less than the repetition rate value.

1. Select the Control Tab.

Important!! The parameters that determine exactly how the COOL PAD function reacts are programmed in two separate screens, (Setup/Outputs/Ventilation/Coolpad and Ventilation Setting/CoolPad). Chore-Time strongly recommends that the factory default settings be used, unless poor control of temperature during pad operation is noticed. Chore-Time also recommends that CTB

2. Measure the number of seconds it takes for water to start coming out of the holes in the pad system's top distribution pipe after turning on the COOL PAD manual toggle switch. This should be entered as the "Water pre-fill time" (**Item 2, right**) and is likely to be different for the different system manufacturers. This amount of time is added to the water run time each repetition because the top distribution pipe drains out during the off time of the on-off cycle.

3. Measure the number of seconds it takes for water to start dripping out the bottom of a dry pad after the COOL PAD manual toggle switch is turned to the on position. This amount of time should be entered as the "Time to wet dry pad" (**Item 3, above**). This will be less than the time to make the pad completely soaked. When the actual water on time reaches this "Time to wet dry pad" value, the next step is to run the water continuously, assuming that the temperature is above the Cool Pad Range at the next temperature check point.

4. If water running on the pad continuously is not desired, then the "Max water allowed" value (**Item 4, right**) should be changed so that it is less than the repetition rate time. Once the temperature decreases back below the Cool Pad Range, the actual water on time will return to the "Time to wet dry pad" value again. From there the water on time changes in the normal way, with 5 second changes every 20 minutes, depending on the temperature check points.

5. The "Actual water on time" is for information only. Showing the value makes it possible to create a graph of its variations if you have the PC connection (C-Central). The "Flush cool pad", (**Item 5, previous page**) is a feature that allows you to run the water continuously at a time of day each day for the duration you specify. This will guarantee that at least once a day the pad will be flushed to keep it as clean as possible and help lengthen the pad life. Leaving dashes for the settings disables this feature. Flushing the pad in the night will have the advantage of causing very little unwanted temperature drop.

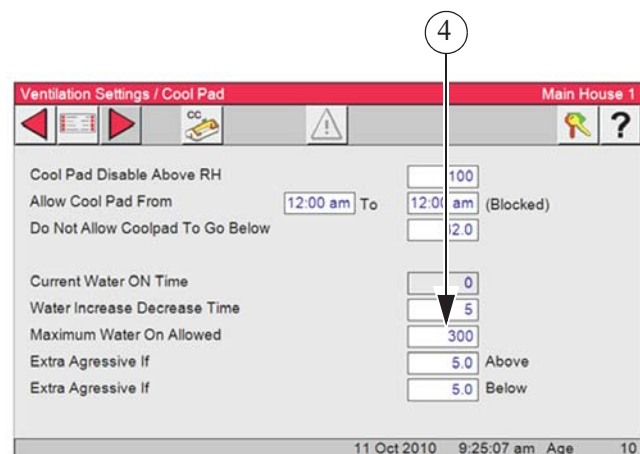
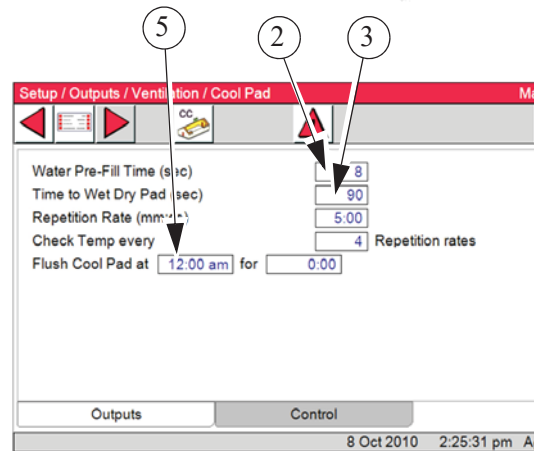
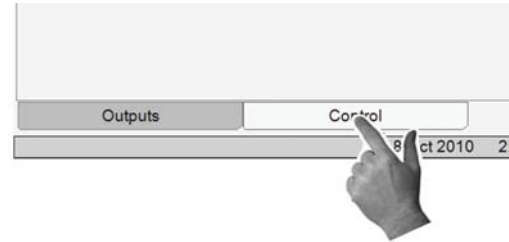

Ventilation-Heat Zones

1. Select the Ventilation button.

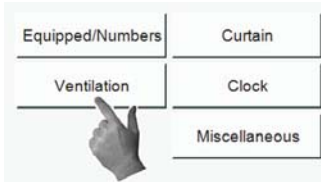

2. Select the Heat Zones button.

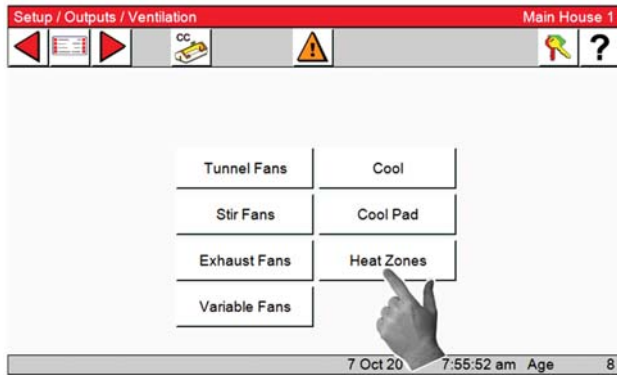

3. Assign Relays, Sensors, Mode values and Names just as you did for Tunnel Fans. (See previous)

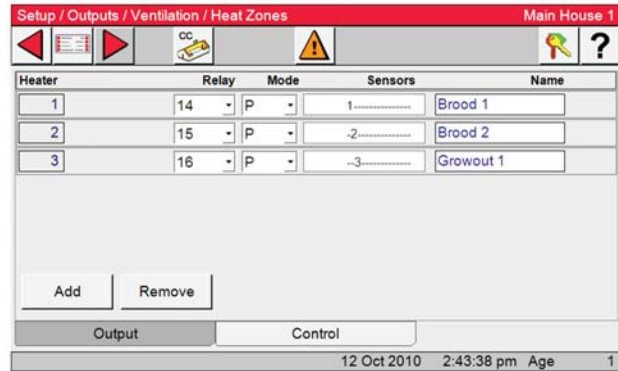

4. Select the Control Tab.

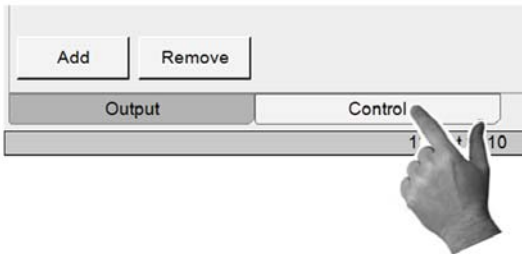

5. Select the box if you do not want the Heat Zones to run in Tunnel assist.

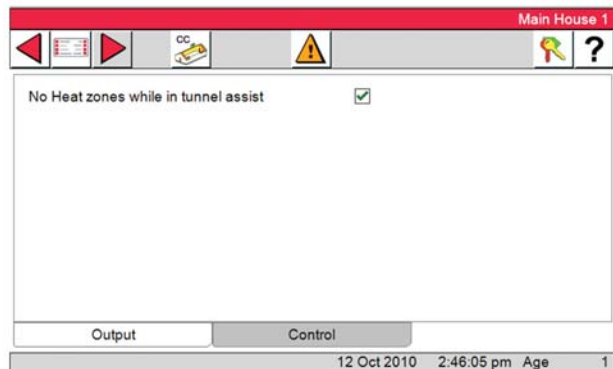

Curtain

1. Use the Back button to get to the Setup/Outputs screen and push the Curtain Button.

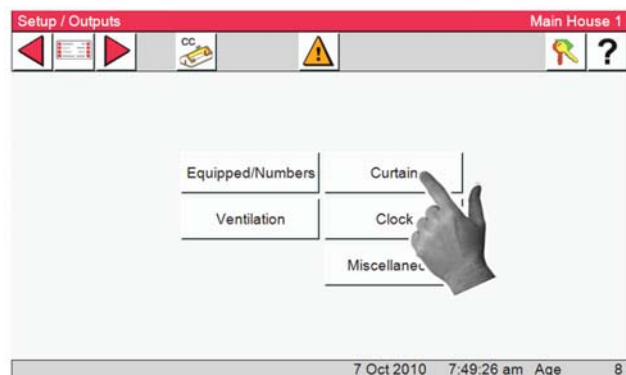

Sidewall Inlet

2. In this screen you will assign Relays to any and all of the air inlets connected to the Control.

3. Select Sidewall Inlet

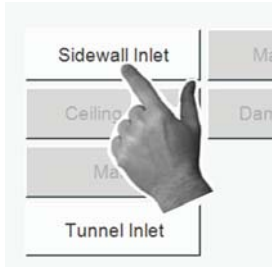

Once you enter in the Open relay number the Control will automatically enter the Close relay. Two inlet machines can be assigned to the Sidewall inlet output. Both machines will be given an open or close signal at the same time.

Open Relay Number Close Relay Number

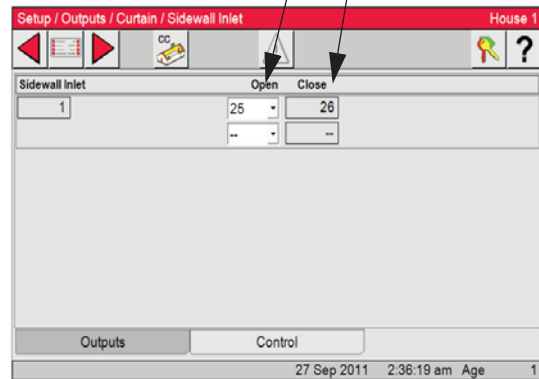

Note. The Open and Close outputs must always be side by side on the same relay row.

4. Select the Control tab and choose Calculated or Fixed Anticipation.

Calculated Inlet Anticipation– The Control determines the amount of time the Inlets will open prior to the Fans assigned to the Minimum Ventilation timer turn on at a given static pressure control limits. **(Screen not shown)**

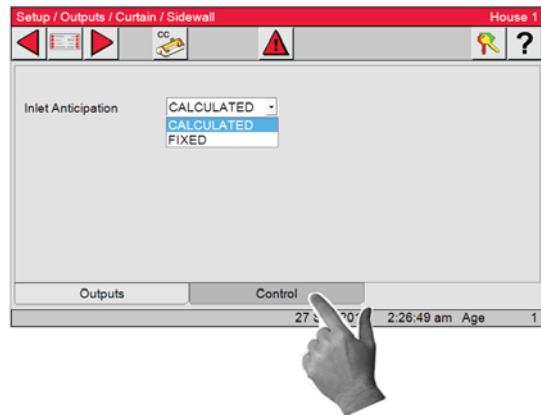

Fixed Inlet Anticipation- The amount of time the Inlets will open prior to the Fans assigned to the Minimum Ventilation timer turn on.

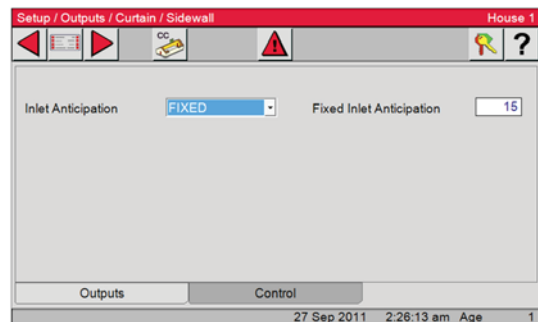

Tunnel Inlet

1. Use the Back button to get to the Setup/Outputs screen and push the Tunnel Inlet Button.

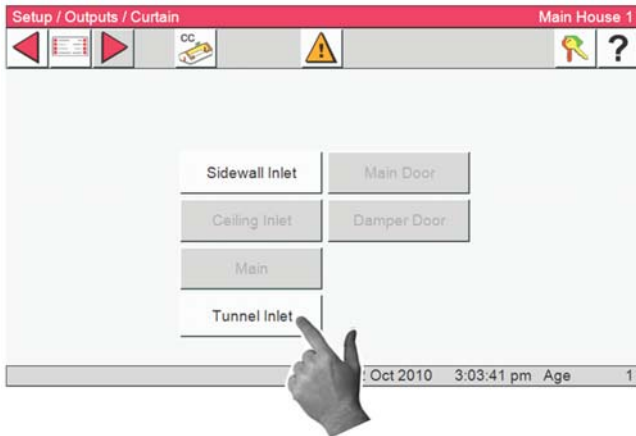

3. Press the Control Tab

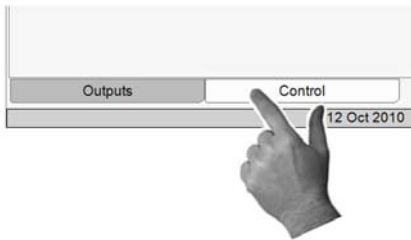

2. When you enter in the Open relay number the Control will automatically enter the Close relay.

Up to four machines can be assigned to the Tunnel inlet output. All machines will be given an open or close signal at the same time.

Note. The Open and Close outputs must always be side by side on the same relay row.

Open Relay Number

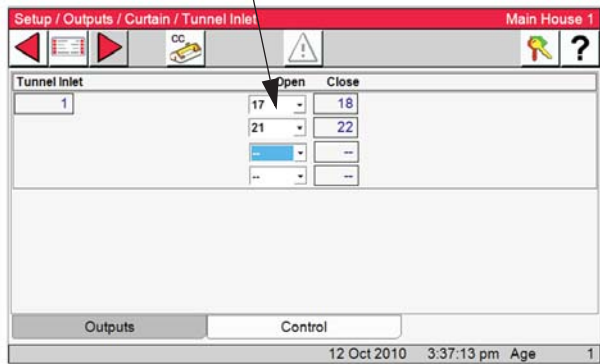

4. These numbers are needed for proper Mode transitions. (Power to Tunnel and Tunnel to Power).

Full Movement

Measure the full movement of the Curtain or Tunnel door and enter that number in the FULL Movement edit box.

Tunnel Speed

With a closed inlet measure 18 inches of the tunnel curtain or door movement. Toggle the open relay switch to the Manual position. Time how long it takes to move the the Inlet 18 inches. Enter that number in to the Tunnel Speed edit box.

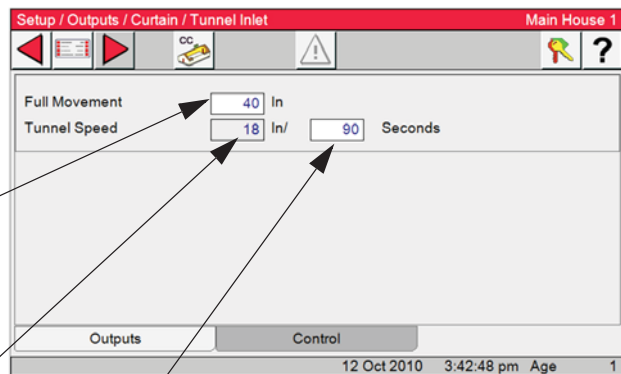

Clock Assignments

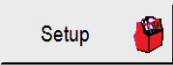
1. Select the Main menu button.  Select the Setup button  from the Main Menu screen. Finally, select the **Outputs** button.

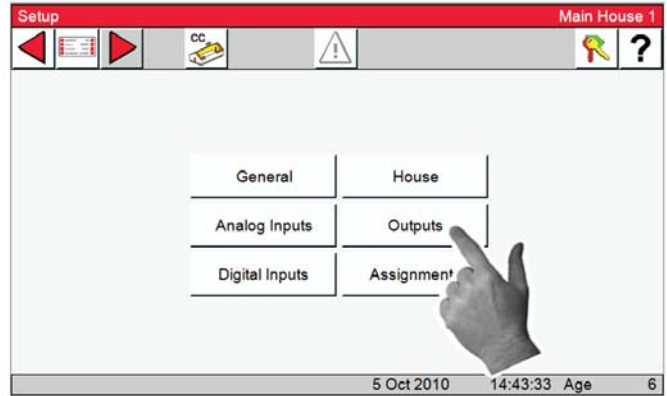

2. Press the Clock button. All of the Clock output Relays are assigned here.

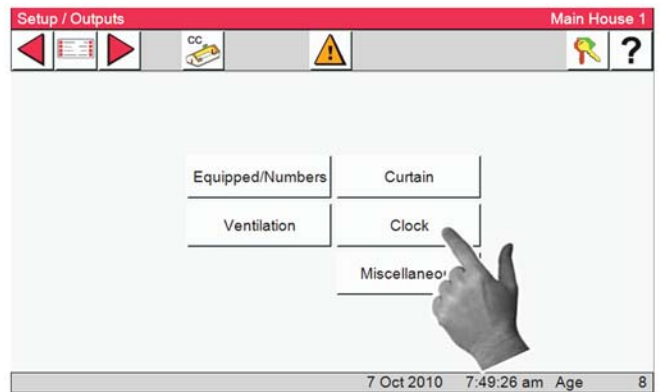

Light Clock

1. Press the Light button.

2. Up to four Light clocks can be assigned with four relays for each Light clock. Use the Add button to add additional clocks.

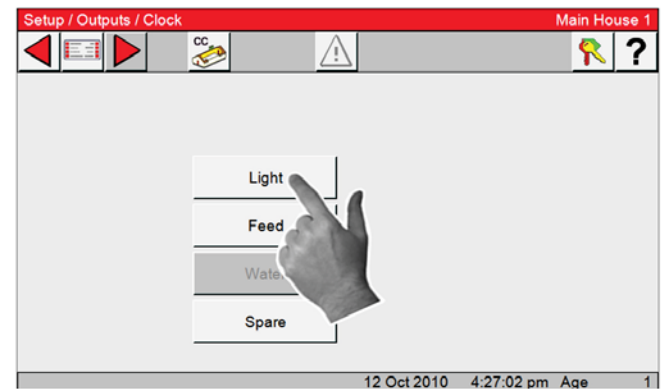

External Light Dimmer Control

3. In the "An Out" column, select from the drop-down the Analog out (on the IO board) used to control the Dimmer.

4. In the Output from column select ether 0-10 vdc or 10 to 0 vdc. (0 vdc = no light or 10 vdc = no light)

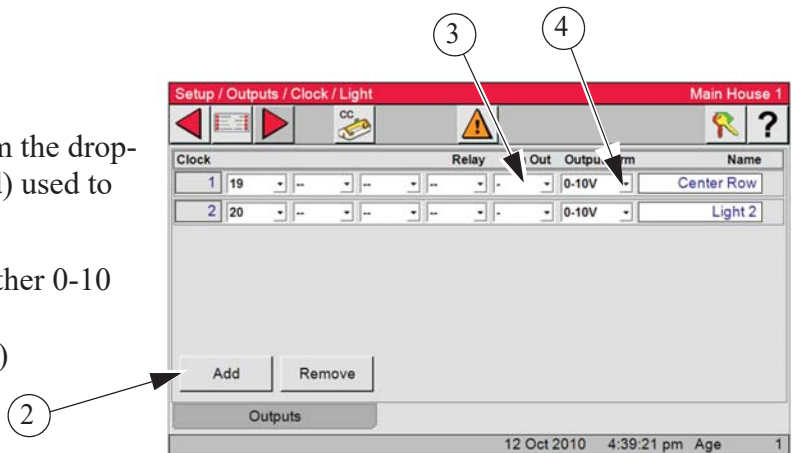

Feed Clock

1. Press the Feed button.

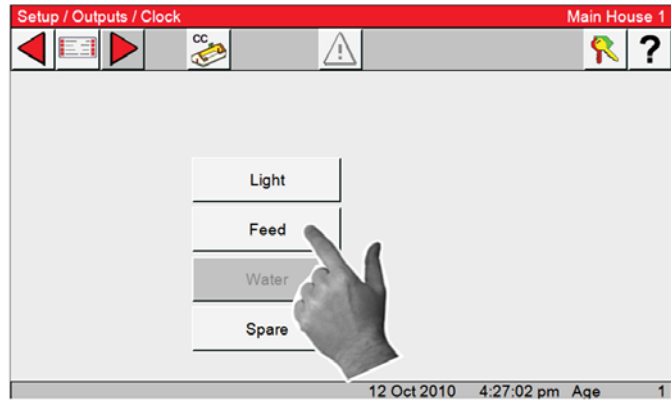

2. Enter the Relay or Relays that the feeders have been wired to. Only one Feed clock can be assigned with up to four relays. All four relays will be activated at the same time.

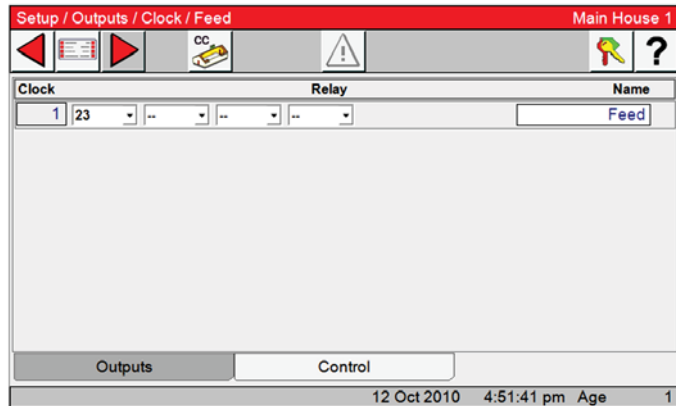

3. Select the Control Tab.

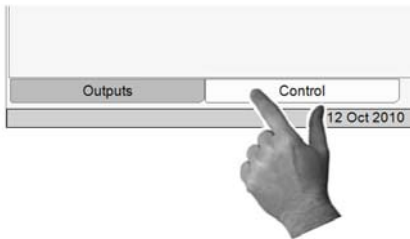

4. If the you wish to turn the Fill System OFF, check the box.

If a Dry Contact Relay whose coil is energized when the fill system's Hopper Level Switch calls for the fill system to run is connected to a digital input of the Control Then the Control can be set to detect excessive fill system run time and activate the Alarm Relay.

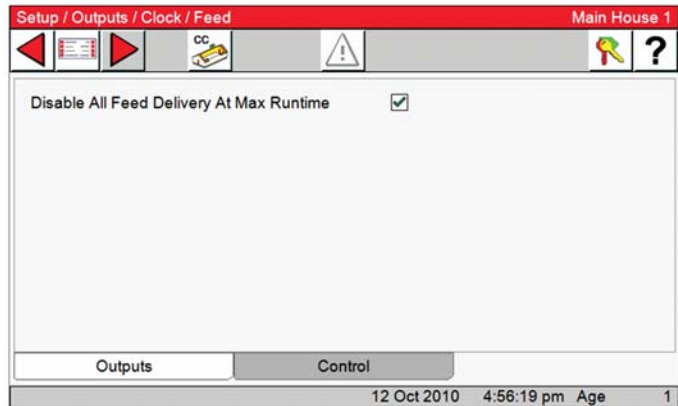

Spare Clock

1. Press the Spare button.

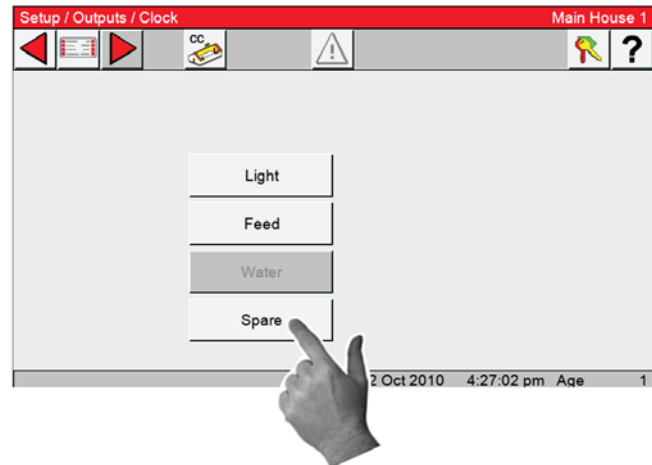

2. The Spare Clocks have 8 on and off events and cannot be curved. A maximum of 8 Spare Clocks can be used, with up to four Relays per Clock. To add additional Spare Clocks to the list, select the Add button. Each Spare Clock can be given a specific name to identify the Clock with a particular use. Enter the Relay number (s) For each Clock in the list and change the name if needed.

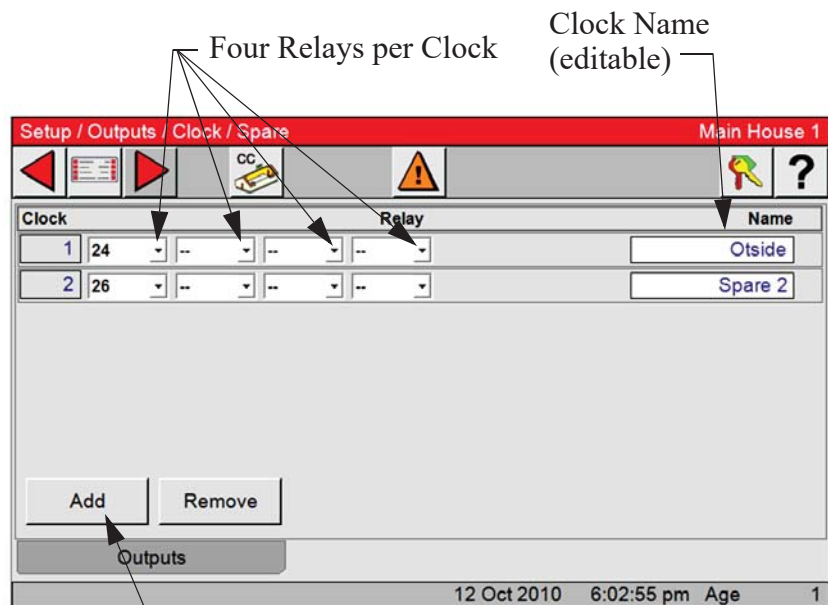

Miscellaneous Outputs

Backup Relay

1. Select the Main menu button.  Select the Setup button  from the Main Menu screen.

2. Press the Outputs button.

3. Press the Miscellaneous button.

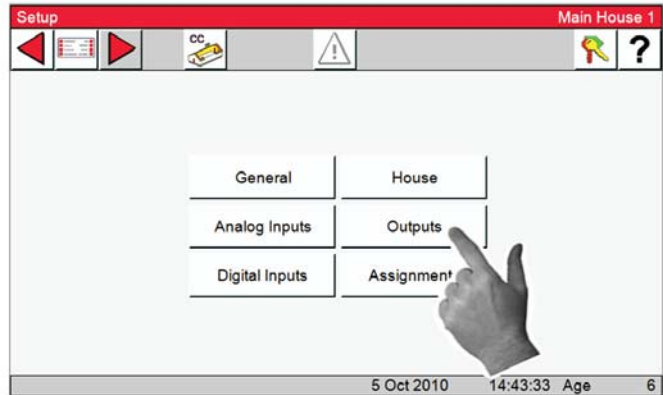
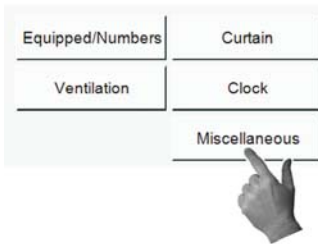

4. select the Backup  button.

5. Assign a Backup relay from the drop-down list of available Relays.

Backup Relays are needed when the Chore-Tronic's Standard or Expanded backup is installed for backing up the Control. If the the brain of the Control goes down for any reason, the Backup Relay will open, and the first stage of backup will be activated. **See backup wiring diagram** in the Backup installation manuals. Part # MT1805A of MT1561b

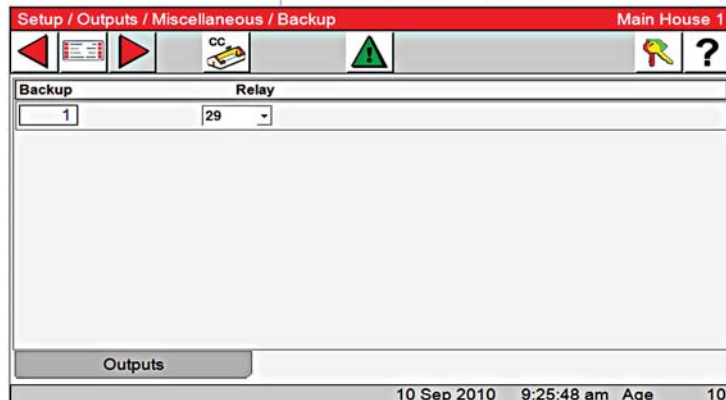
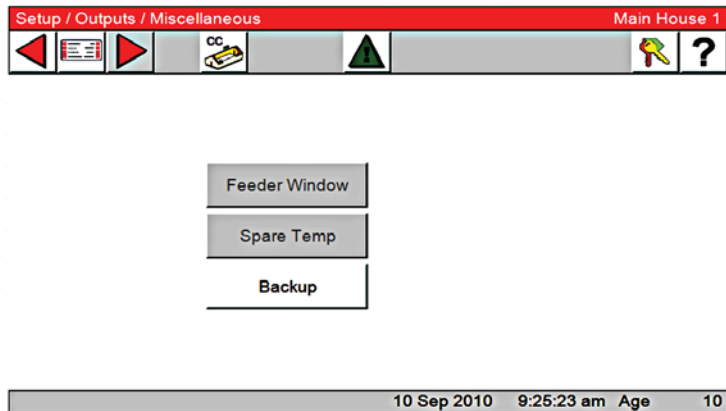

Verify Relay Assignments

After assigning all the outputs, verify the Relay assignments with the Output Stickers on the Manual Toggle Switches.

Relay # Relay Assigned To...		
1	Feed Clock 1	29
2	Feed Clock 2	30
3	Feed Clock 3	31
4		32
5		33
6		34

Relay Assignments
(Inside Cover of Relay Box)

Manual Toggle Switches

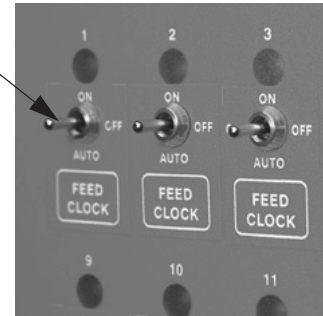

Assignments

Sensors

1. Select the Main menu button.  Select the Setup but-

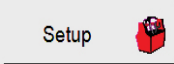
ton  from the Main Menu screen.

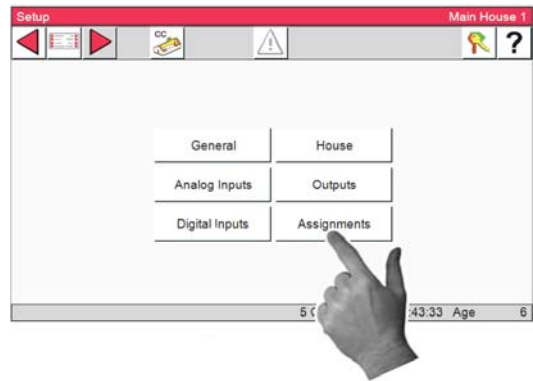

2. Select the Sensor button.



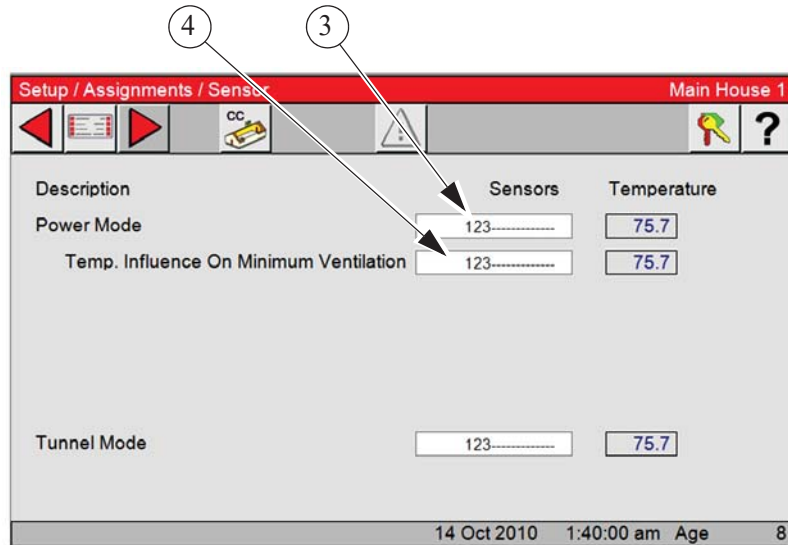

3. Power Mode- The temperature sensor (s) assigned here will determine what the control will use to transition from Power to Tunnel mode.

4. Temp. Influence On Minimum Ventilation

The temperature sensor (s) assigned here will determine the amount of time added or subtracted away from the Minimum Ventilation timer in Power mode.

For this feature you must first check the box in the (Setup/house screen) for Temp. Influence On Minimum Ventilation.

Ventilation timer ramping-

If the sensor(s) that are assigned to the Minimum Ventilation fan(s) temperature is at or below set temperature then the fans will use the ON and OFF times that are listed for the Minimum Ventilation Timer. If the sensor (s) assigned to the Ventilation Time Ramping temperature is between set temperature and the fans' ON temperature the control will adjust the amount of ON time between the Min Ventilation value and the Max value. The OFF time will be adjusted by the same amount of time that the ON is adjusted, thus keeping the total cycle time constant. The temperature is checked 30 seconds before the beginning of the ON time cycle of the Minimum Ventilation Timer. Once the fans' temperature sensor(s) reach the fans' ON temperature, the fan will turn on and run continuously until the fans' OFF temperature is reached.

Example: The set temperature is 70.0°F and the fans assigned to the Min Vent timer ON temperature is 72.0°F. The Minimum Ventilation Timer values are 30 seconds ON time and 270 seconds OFF time. The maximum ON time is 210 seconds. If the sensor(s) assigned to the Ventilation Time Ramping temperature is 71.0°F at the beginning of the anticipation cycle, then the fans will have an ON time of 125 seconds and an OFF time of 175 seconds

Function

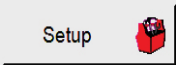
1. Select the Main menu button.  Select the Setup button  from the Main Menu screen.

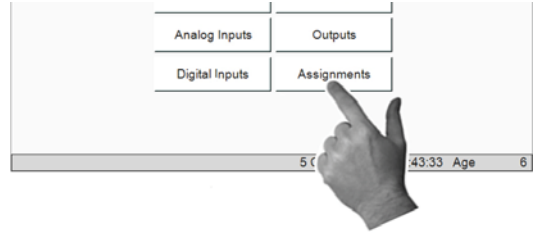

2. Select the Function button.

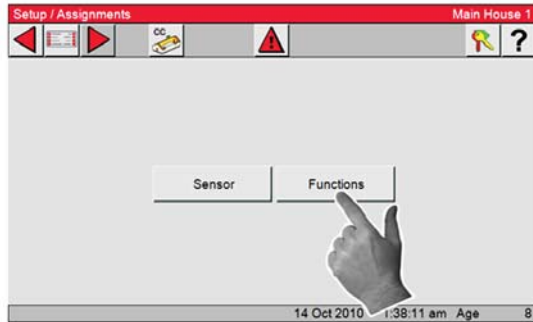

3. Alternate Min Vent Fans **(Select if you want feature)**

The Min Cycle (Alternate Minimum Ventilation fans) allows the fan(s) assigned to the Min Vent Timer to alternate with the fans assigned to the Min Cycle. In the above example, Exhaust Fans 1 and 2 will run on the Min Vent timer first. At the next ON time of the Min Vent Timer the fans assigned Exhaust Fans 3 and 4 (the fans assigned to the Min Cycle) will run. The feature will stop when the fans assigned to the Min Vent Timer turn on due to temperature.

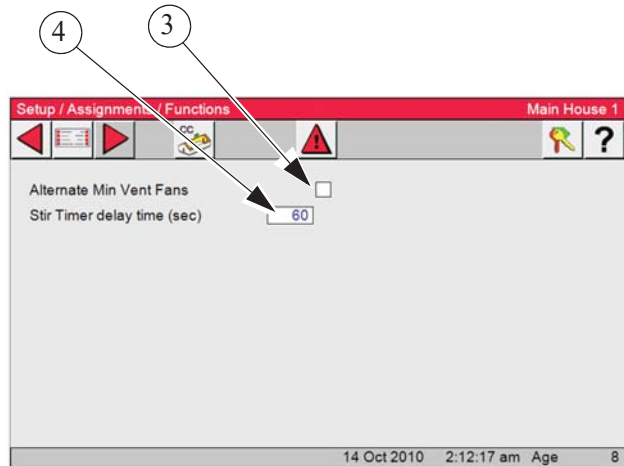



4. Stir Timer Delay time (sec)

Enter the amount of time you want the Stir fans to delay after the Min.Vent. fans have turned off.

In screen Setup/Output/Equipped, Stir fans must be checked, and at least one Relay assigned in the Setup/Outputs/Ventilation/Stir Fans screen to use this feature.

Ventilation Settings

Set Temp Timer

1. Select the Main menu button.  Select the Ventilation Settings button. 

2. Select the Set Temp Timer button.

Note: Only the values with a white background are editable. All other boxes are information only.

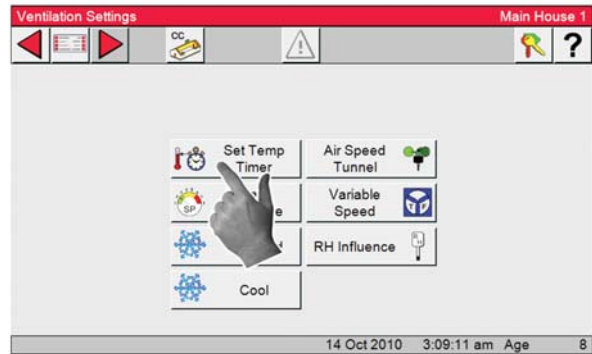

3. Set temperature

Set Temperature is a very important parameter. All other temperatures are dependant on the set temperature. When the set temperature is changed, all other temperature settings are also changed by the same amount to maintain the same temperature differences relative to the set temperature.

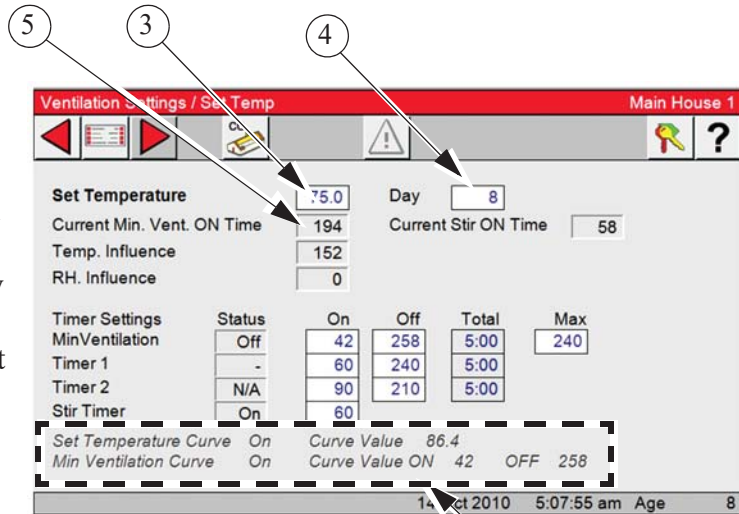

4. Day

Day is the age of the animals or birds. Changing the age with Set temp and or Min Vent curve on will change their values to the current curve values.

5. Current Min.Vent. ON Time

Current Min. Vent. ON Time is the current amount of ON time the fans assigned to the Minimum Ventilation Timer will run while cycling on the timer. This amount of time compines both Temperature and if being used RH influence. If (TMP) is displayed the Min. Vent. Fan (s) are on by temperature.

6. The status of the Set Temperature and Min Vent curve and curve values are displayed at the bottom of this screen.

The Temp Curve and Min Vent Curve "on" indications are not editable. They only indicate that the curve(s) are "on" and the curve's value. If a curve is not "on", there is no indication in this area. The values shown at the bottom of the screen are the current curve's values. If the actual values are different, the difference represents the "offset". Editing the actual values to be the same as the values displayed at the bottom of the screen will erase the offset(s). An "offset" is caused if you change a value when its curve is on.

7. Current Stir ON Time

Current Stir ON Time is the current amount of Stir On Time. If (TMP) is displayed the Stir Fan (s) are on by temperature.

The "stir on" Timer is different than the other Timers. It can only be attached to Stir Fan Outputs in the "Outputs" screen. The "stir on" time value is set in this screen. The purpose of this feature is to allow you to cause a Stir Fan Output to run for the "stir on" amount of time immediately following the end of the Minimum Ventilation Timer's "on" time. Because of this, the Stir Fan is synchronized with the minimum ventilation Timer. The "stir on" setting can be any value up to the "off" time of the minimum ventilation Timer. The Stir Fan Outputs will come on full when the temperature rises to the "on" temperature value set in the "Outputs and Temperature" screen.

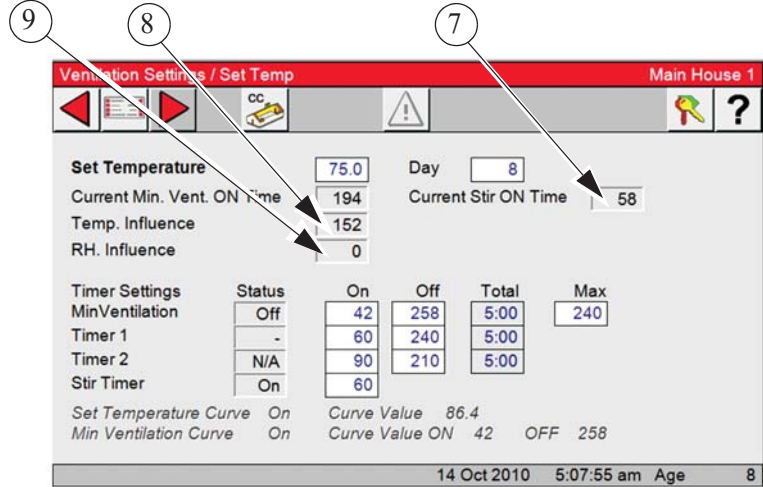

8. Temp. Influence

is the amount of time added by Ventilation timer ramping- If the sensor(s) that are assigned to the Minimum Ventilation fan(s) temperature is at or below set temperature then the fans will use the ON and OFF times that are listed for the Minimum Ventilation Timer. If the sensor (s) assigned to the Ventilation Time Ramping temperature is between set temperature and the fans' ON temperature the Control will adjust the amount of ON time between the Min Ventilation value and the Max value. The OFF time will be adjusted by the same amount of time that the ON is adjusted, thus keeping the total cycle time constant. The temperature is checked 30 seconds before the beginning of the ON time cycle of the Minimum Ventilation Timer. Once the fans' temperature sensor(s) reach the fans' ON temperature, the fan will turn on and run continuously until the fans' OFF temperature is reached.

Example:

The set temperature is 70.0°F and the fans assigned to the Min Vent timer ON temperature is 72.0°F. The Minimum Ventilation Timer values are 30 seconds ON time and 270 seconds OFF time. The maximum ON time is 210 seconds. If the sensor(s) assigned to the Ventilation Time Ramping temperature is 71.0°F at the beginning of the anticipation cycle, then the fans will have an ON time of 125 seconds and an OFF time of 175 seconds.

9. RH Influence

The actual amount of influence time the RH function is adding to the minimum ventilation timer. The Control may not always add the full amount of time if the amount of influence would add up to be more than the maximum allowed.

Timer Settings

1. Min Ventilation Timer

Min Ventilation Timer can be attached to Exh Fan, Tun Fan, and Stir Fan Outputs in the "Outputs" screen. The "on" and "off" times for this Timer are set up here in there. The Timer turns the Fan on or off when the temperature is below the Fan's "on" temperature. A Timer can only be attached to a Tun Fan Output if the "on" temperature setting of the Tunnel Fan is set lower than the "on" temperature of the Tunnel Mode.

Allowable "on" times for this Timer are 0 or greater than 30 seconds (5 through 29 seconds is only allowed if fixed Anticipation is used). Allowable "off" times for this Timer are 0 or greater than 60 seconds (1 through 59 seconds is not allowed). The "on" and "off" times cannot both be set at 0.

Timer Settings	Status	On	Off	Total	Max
MinVentilation	Off	42	258	5:00	240
Timer 1	-	60	240	5:00	
Timer 2	N/A	90	210	5:00	
Stir Timer	On	60			

2. Max Ventilation On Time

Max Ventilation On Time-The maximum amount of ON time the fans assigned to the Minimum Ventilation timer can run before reaching the fans' ON temperature. The maximum allowed value for the Max Ventilation On Time is the amount of ON time (seconds) + the amount of OFF time(seconds) of the Min Vent timer - 60 (seconds).

3. Timers 1 and 2

Timers 1 and 2 can be attached to Cool, Tun Fan, Exh Fan, and Stir Fan Outputs in the "Outputs/ Temperature" screen. The "on" and "off" times for these Timers are set in this screen. These Timers behave like the minimum ventilation Timer except when they are attached to a Cool Output. When attached to a Cool Output, the timer has no effect until the Cool Output is "on" due to its temperature settings. At that point the Cool Output goes on and off with the Timer. The Cool Output never comes on continuously when Timer 1 or Timer 2 is attached to it. There are no limitations to the "on" and "off" settings for Timer 1 and Timer 2 except that the "on" time and "off" time cannot both be set at 0.

4. Stir Timer

is different than the other Timers. It can only be attached to Stir Fan Outputs in the "Outputs" screen. The "stir on" time value is set in this screen. The purpose of this feature is to allow you to cause a Stir Fan Output to run for the "stir on" amount of time immediately following the end of the Minimum Ventilation Timer's "on" time. Because of this, the Stir Fan is synchronized with the minimum ventilation Timer. The "stir on" setting can be any value up to the "off" time of the minimum ventilation Timer. The Stir Fan Outputs will come on full when the temperature rises to the "on" temperature value set in the "Outputs" screen

5. Status

Status-The status column shows the current status of each of the timer. If the Status is ON then the timer is active and the Output(s) currently assigned to that timer should be running. If the Status is OFF, then the timer is active, but the Output(s) assigned to that timer should NOT be running. If the Status is "-" or "tmp", then the timer is not currently active and the Output(s) assigned to that timer may or may not be running (depends on the type of Output due to temperature). If there is a NA (not active) in the Status column then the timer is not assigned to any Outputs and will not be active.

Static Pressure

The Static Pressure screen indicates the current static pressure plus provides the fields that can be edited to set the Static Pressure Control limits and the wind delay. The open and close Inlet Relays respond as required to keep the static pressure within the Control limits while in the Power Mode and the open and close Tunnel Curtain Relays do the same to control the static pressure during the Tunnel Mode. If it is not desired to control the static pressure during the Tunnel Mode, the high control limit in the Tunnel Mode must be edited to be .00. Static Pressure Control w/ Tunnel Curtain during Power Mode-If in the Power Mode, there is inadequate inlet area to keep the static pressure within the high control limits, the Tunnel Curtain will open to give additional air inlet area. The Inlets are given continuous open signals as the Tunnel Curtain takes over the responsibility of controlling the static pressure. The static pressure has to be above the high Static Pressure Control limit continuously for one minute with 3 or more Fans running for this to happen. Responsibility for Static Pressure Control is passed back to the Inlets as soon as there are fewer than 3 Fans running or the Tunnel Curtain cannot bring the static pressure back into the control range (while closing) from the low side. The static pressure has to be below the low Static Pressure Control limit continuously for one minute for this to happen.



2. Select the Static Pressure button.

3. **Current Static Pressure**- The amount of static pressure currently measured by the Control.

4. **Current Static Pressure Limits**- The Current SP Limits are the current high and low limit settings the Control is using to control the inlets or tunnel curtain.

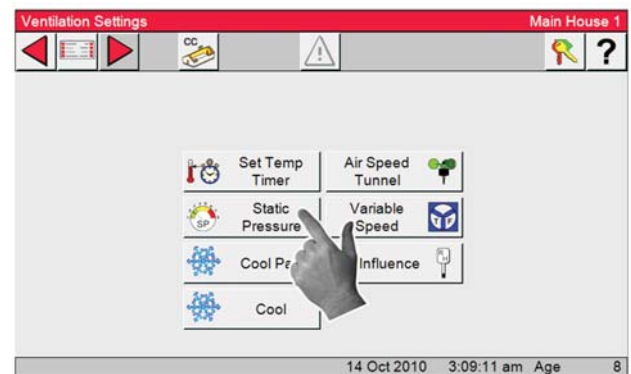

5. **Static Pressure Control Limits**- The Static Pressure Control limits are the values of static pressure the Control attempts to maintain by using the powered Inlets, the Tunnel Curtain, or both. A second level of Power Mode static pressure can be chosen in the (Setup/Analog Inputs/Static Pressure) screen in the Control tab. The temperature at which the second static pressure takes over is entered in the (Output/Temperature) screen. The Temperature Sensor(s), (Inside Only), that measure that temperature is defined in the (Setup/Analog Inputs/Static Pressure) screen.

6. **Fixed Inlet Anticipation**- Fixed Inlet Anticipation is the amount of time the inlets will open prior to the fans assigned to the Minimum Ventilation timer turn on. Fixed inlet anticipation must be selected from the (Setup/Analog Inputs/Static Pressure) screen in the Control tab.

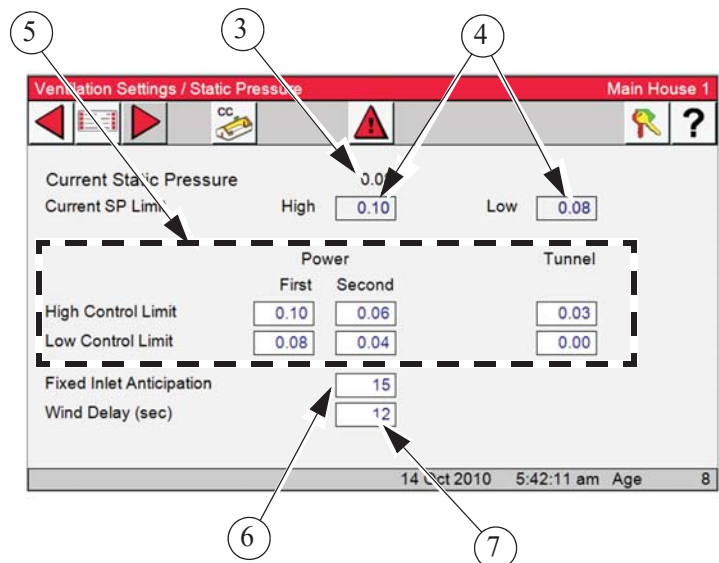

7. **Wind Delay**- The wind delay is the amount of time the static pressure has to be continuously outside of the Control limits before the appropriate open or close Relay will be energized to bring the static pressure back within the control limits. The wind delay is bypassed if a Fan or Fans turning on or off is what causes the static pressure to move outside the Static Pressure Control limits

Cool Pad

The parameters that determine exactly how the COOL PAD function reacts are programmed in two separate screens, (Setup/Outputs/Ventilation/Coolpad and Ventilation Setting/CoolPad). Chore-Time strongly recommends that the factory default settings be used, unless poor control of temperature during pad operation is noticed. **Chore-Time also recommends** that CTB service personnel is contacted before changing the settings.

1. Select the Main menu button.  Select the Venti-

lation Settings button. 

2. Select the Cool Pad button.

3. Measure the number of seconds it takes for water to start coming out of the holes in the pad system's top distribution pipe after turning on the COOL PAD manual toggle switch. This should be entered as the "Water pre-fill time" (**Item 3**) and is likely to be different for the different system manufacturers. This amount of time is added to the water run time each repetition because the top distribution pipe drains out during the off time of the on-off cycle.

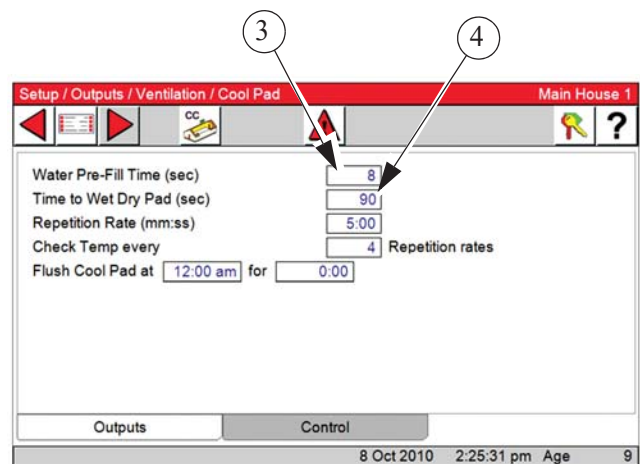
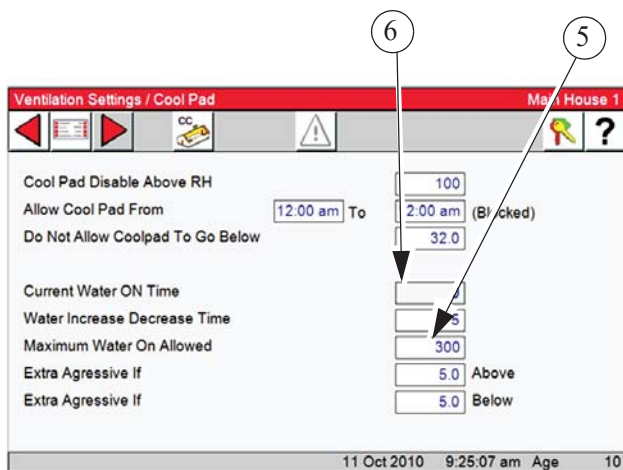
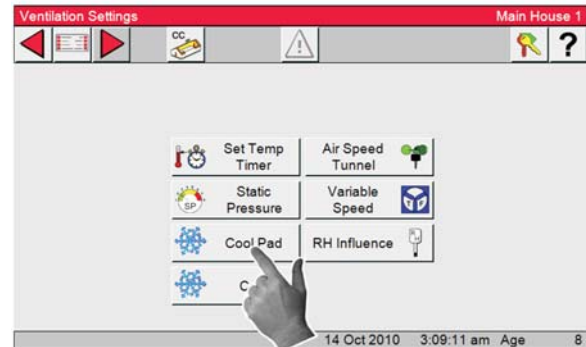

Setup/Outputs/Ventilation/Coolpad Screen...

4. Measure the number of seconds it takes for water to start dripping out the bottom of a dry pad after the COOL PAD manual toggle switch is turned to the on position. This amount of time should be entered as the "Time to wet dry pad" (**Item 4**), This will be less than the time to make the pad completely soaked. When the actual water on time reaches this "Time to wet dry pad" value, the next step is to run the water continuously, assuming that the temperature is above the Cool Pad Range at the next temperature check point.

5. If water running on the pad continuously is not desired, then the "Max water allowed" value (**Item 5**), should be changed so that it is less than the repetition rate time. Once the temperature decreases back below the Cool Pad Range, the actual water on time will return to the "Time to wet dry pad" value again. From there the water on time changes in the normal way, with 5 second changes every 20 minutes, depending on the temperature check points.

6. **Actual water on time-** For information only. Showing the value makes it possible to create a graph of it's variations if you have the PC connection (C-Central).

Cool Setting

1. Select the Main menu button.  Select the Ventilation Settings button. 



2. Select the Cool button.

3. **Cool Outputs Disabled Above RH-** If there are relays assigned to cool output(s), and a relative humidity sensor is connected to the Control, the Control can block the cool output from turning on if the relative humidity sensor reading is higher than entered value.

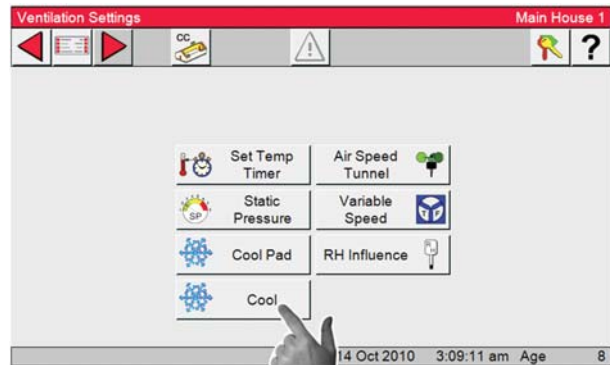

4. **Allow Cool From-** User can also specify a specific time of day in which the cool outputs are allowed to operate. A setting of 12:00a to 12:00a means that the cool outputs are allowed to operated 24 hours per day.

5. **Do Not Allow Cool To Go Below-** Outputs can have a minimum temperature setting. If the cool or Cool Pad outputs reach this minimum temperature due to the set temperature changing the outputs will not go below this minimum temperature even though the set temperature may continue to lower due to the set temperature curve.

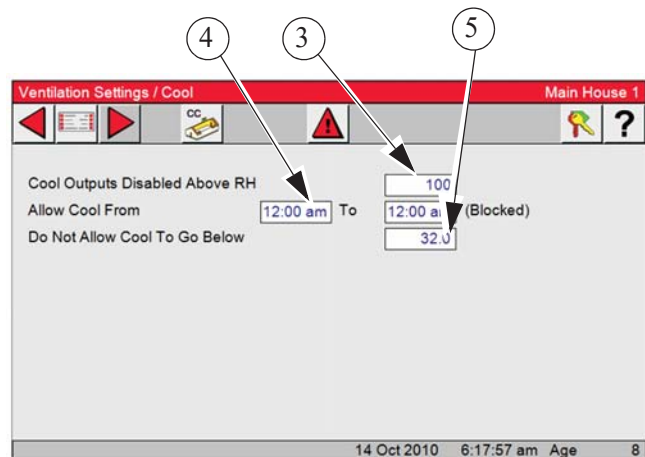

Airspeed Tunnel Settings

1. Select the Main menu button.  Select the

Ventilation Settings button. 

2. Select the Air Speed Tunnel button.

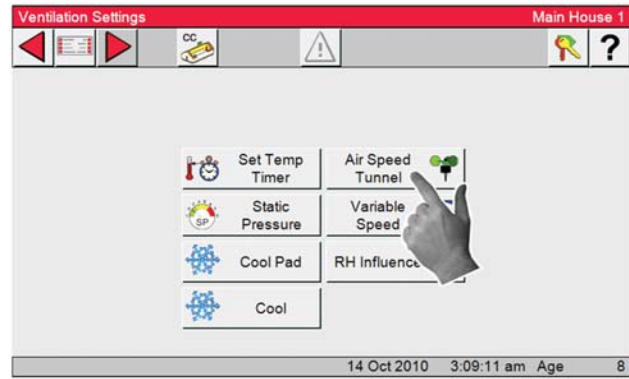

3. Selecting Airspeed Control in Tunnel-

To activate put a Check Mark in the Box as shown. This function is used to maintain a minimum airspeed while in Tunnel mode. After making the transition from Power to Tunnel mode, the Control will turn on enough Fans until the airspeed reaches the speed entered in the Start turning on Fans Below line above. When coming out of full tunnel, the Control will continue to allow fans to turn off according to temperature until the airspeed reaches the number entered in the **Start turning Fans off line (Item 1, Right)**.

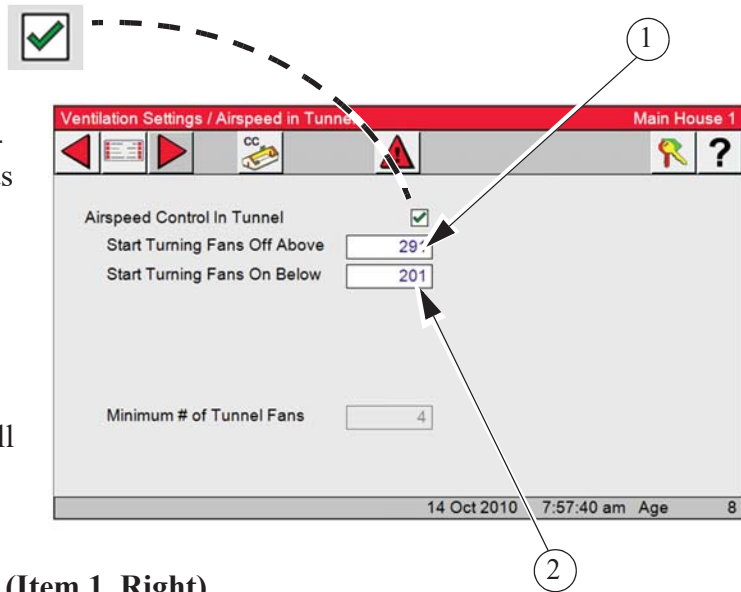

Example: Using the settings above, when the Control completes the transition to Tunnel Mode, the Control will check to the airspeed to make sure it at or above the Start turning on Fans Below setting. It will turn on Fans until the minimum airspeed is reached. The Control will stop allowing Fans to turn off once the airspeed drops below the number entered in the **"Start turning off Fans"** box (Item 2, above). It will maintain that airspeed until the control reaches the Tunnel Off temperature.

Deselecting Airspeed Control in Tunnel-

Enter the minimum number of Tunnel Fans needed in Tunnel. The number of Fans entered will stay on until the control transition back to Power, overriding the fans off temperature setup in the (Outputs/ Temperature) screen. The tunnel fans picked will be the first Tunnel fans in the (Outputs/Temperature) setup.

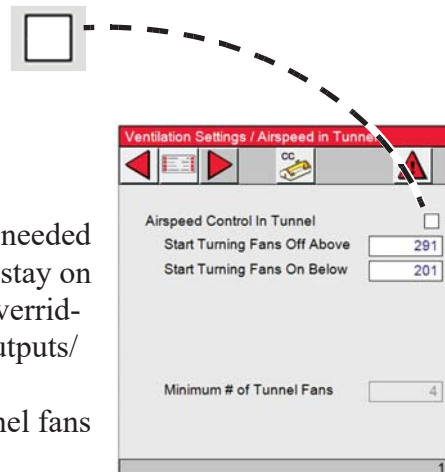

Variable Speed Settings

1. Select the Main menu button.  Select the Ventilation Set-

tings button. 

2. Select the Variable Speed button.

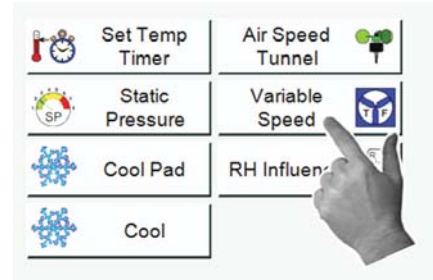

4. **Variable Speed Maximum-** Enter the maximum speed in percent that you want to operate the Var. Speed fan.

3. **Current Speed-** is the current speed in percent and cannot be edited.

5. **Variable Speed Minimum-** Enter the minimum speed that you want to operate the Var. Speed fan.

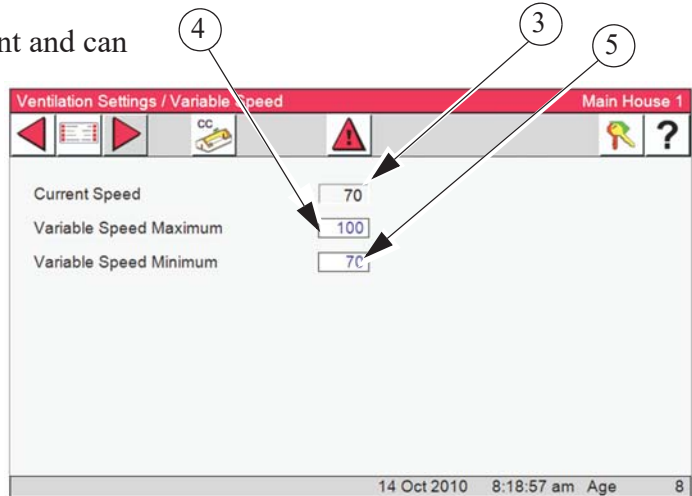

RH (Relative Humidity) Settings

1. Select the Main menu button.  Select the Ventilation Settings button. 

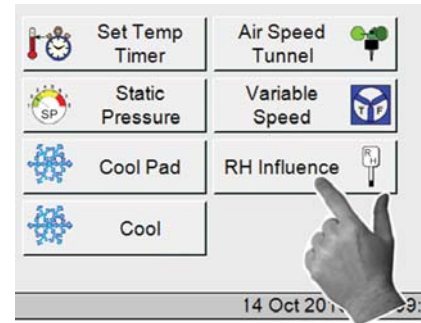

2. Select the RH Influence button.

3. **Actual Influence-** The actual amount of influence time the RH function is adding to the minimum ventilation timer. The control may not always add the full amount of time if the amount of influence would add up to be more than the maximum allowed setup in the (Ventilation Settings/Set Temp) screen.

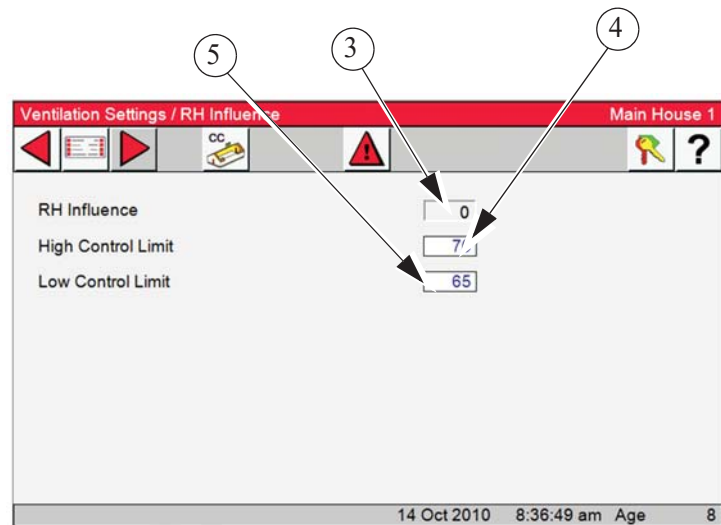

4. **High Control Limit-** If the RH in the house is above this setting than the control will add an increment of on time to the minimum ventilation timer up to the maximum amount of influence allowed or the maximum possible amount of ventilation on time that is set in the (Ventilation Settings/Set Temp) screen.

5. **Low Control Limit-** If the RH in the house is below this setting than the control will subtract an increment of on time to the minimum ventilation timer down to the minimum setting is (Ventilation Settings/Set Temp) screen.

Note: If the RH is between the High and Low Control limit, then the control will neither add or subtract on time to the minimum ventilation timer. The RH is check 30 seconds prior to an ON time cycle of the minimum ventilation timer.

Curves

Curves/Set Temp

1. Select the Main menu button.

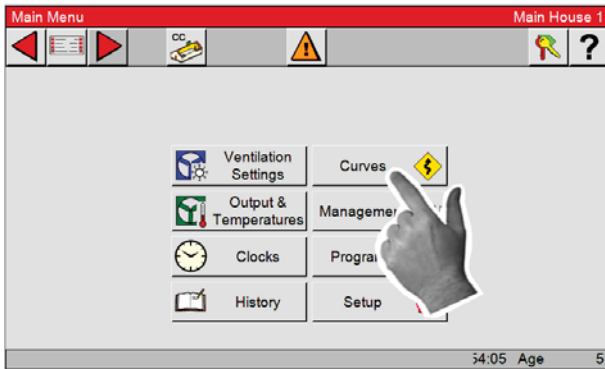

3. Select the Set Temp button.

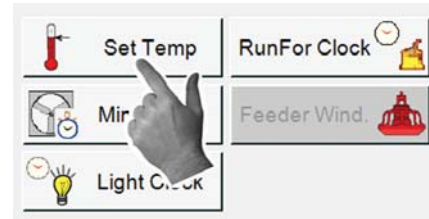

There are several terms that need to be defined in order to understand the Set Temperature Curve Screen.....

4. A **"curve"** is a listing of up to 10 points in time (bend points) that defines how you want a parameter to automatically vary as the animals grow. Turn curves on here.

5. **Curve Value**- This indicates the current value(s) of the specified curve.

6. **The Bend Points (BPs)**- are points on the curve that define the curve. The curve values are adjusted between the Bend Points. The bend point values are the exact values at midnight of the day # of each Bend Point. The curve takes over when you turn the curve "on" and the day number is equal to or greater than the day number assigned to BP #1.

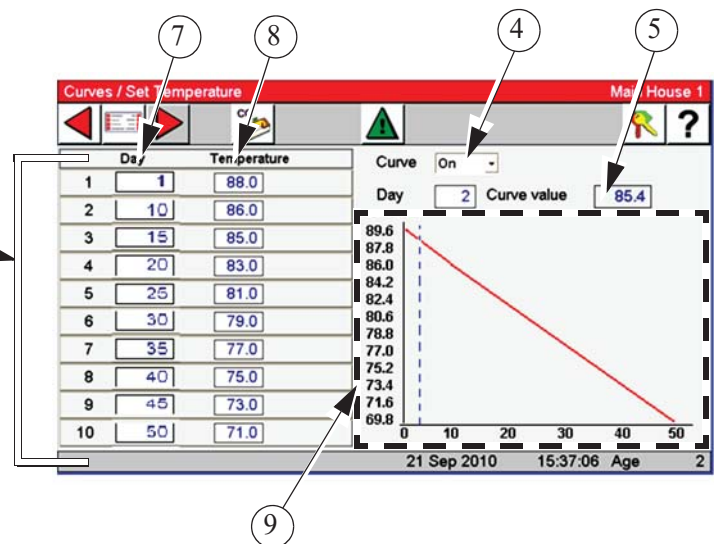

7. **Day**- The intention is that the day # is age of the animals. Negative days (down to - 7) are allowed if it is desired to preheat the house, for example, prior to the arrival of the animals. The day # of a BP can also be negative, if desired. Changing the day # in any screen that shows the day number, will change the day # in all the other screens that show the day #.

8. **Temperature**- is the temperature you want the Set temp.to be at 12:00am on a specific day. Based on the bend points setting the temperature increase or decrease between bend points.

9. **The graphs** on the right side of Set temperature screen shows the progress of the curve. The dashed line indicated the current day number of the curve.

Minimum Vent Curve Settings

1. Select the Main menu button.
2. Select the Curves Button.

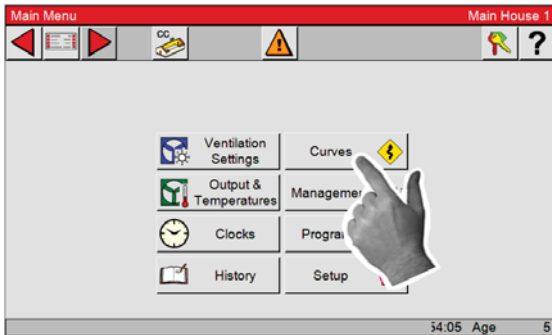

3. Select the Min Vent button.

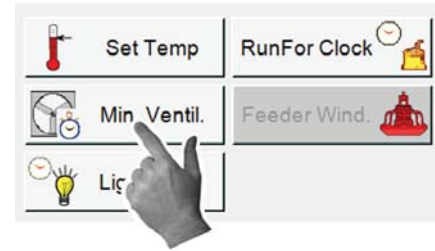

There are several terms that need to be defined in order to understand the Minimum Ventilation Curve Screen.

4. A "curve" is a listing of up to 10 points in time (bend points) that defines how you want a parameter to automatically vary as the animals grow. By turning the curve "on" the Control will follow the curve settings .

5. **Curve Value-** This indicates the current value(s) of the specified curve.

6. **The Bend Points (BPs)-** are points on the curve that define the curve. The curve values are adjusted between the Bend Points. The bend point values are the exact values at midnight of the day # of each Bend Point. The curve takes over when you turn the curve "on" and the day number is equal to or greater than the day number assigned to BP #1.

7. **Day-** The intention is that the day # is age of the animals. Negative days (down to - 7) are allowed if it is desired to preheat the house, for example, prior to the arrival of the animals. The day # of a BP can also be negative, if desired. Changing the day # in any screen that shows the day number, will change the day # in all the other screens that show the day #.

8. **On and Off columns-** are the Min. Vent. time for a specific bend point

9. **The graphs** on the right side of the Minimum Ventilation Curve screen shows the progress of the curve. The dashed line indicated the current day number of the curve.

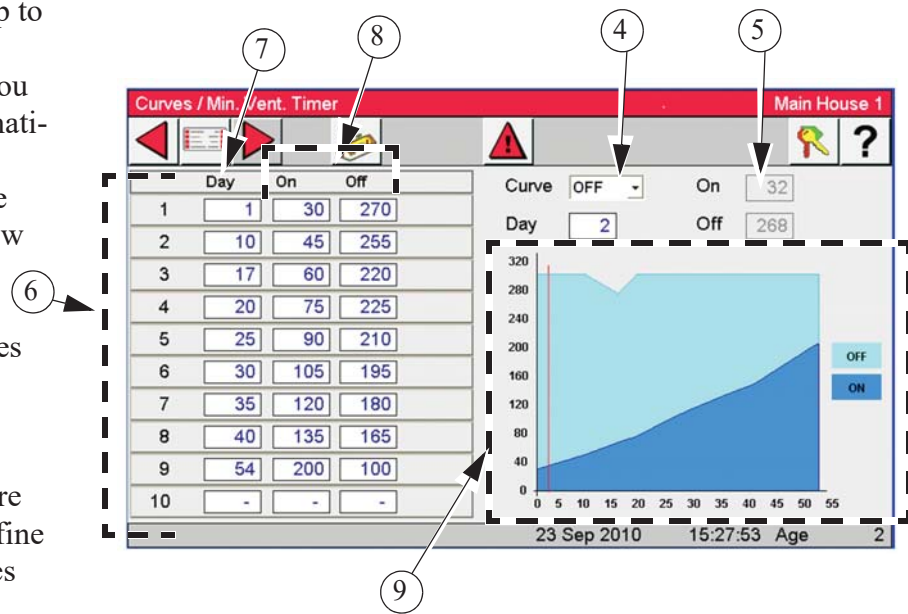

Light Clock Curve Settings

1. Select the Main menu button.



2. Select the Curves Button.

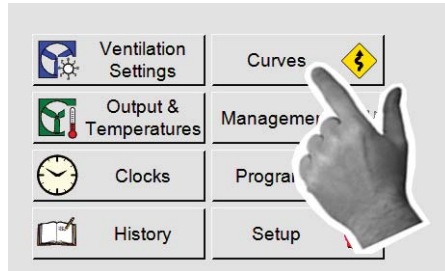

3. Select the Light Clock button.

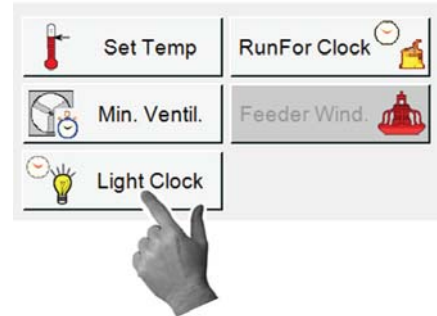

4. **Curves**- Four different curves can be setup and assigned to four different Light clocks. For light level spiking and for the use of independent clocks to control different light types (incandescent and fluorescent for example) within the house. Select the curve you want to setup from the drop down.

5. **Bend Point**- This is the current displayed bend point of the Light Clock Curve. Only one bend point can be shown at a time. Up to ten bend points can be used on each Curve. Select the Bend point you want to setup from the drop down.

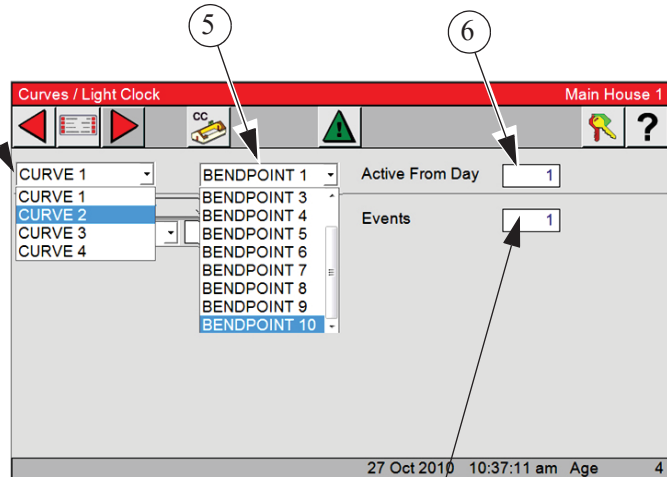

6. **Active From Day**- This is the day that current bend point will become the active light clock settings.

7. **Events**- The Control allows a maximum of 24 events. Each event the user chooses whether the Relay (if used, assigned to the clock turns on or off, what the dimmer (if used) level setting should be at the time of the event and how long it should take to get to that dimmer setting (sunrise/sunset time).

8. **Time**- Enter the time of day.

9. **Relay**- Turns the relay assigned to the Light clock that the curve has been assigned to on or off.

10. Enter the amount of time you want to ramp up or down the output to the Dimmer. If OFF is selected in the relay column the lights will be turned off with no ramping.

	Time	Relay	Dim perc
1	5:00 am	ON	70
2	9:00 am	ON	100
3	10:00 am	ON	70
4	10:00 pm	OFF	0

11. **Dim perc**- Enter the percentage of light level wanted.

See Next Page for Example.....

Example: In the example (right), the lights will turn on at 5:00a and will take 15 minutes to go from 0 percent light to 70 percent light. At 9:00a the lights will take 5 minutes to "spike" up to 100 percent. At 10:00a the light spike is removed immediately (no sunset time) and the lights return to 70 percent. At 10:00p the lights are immediately turned off.

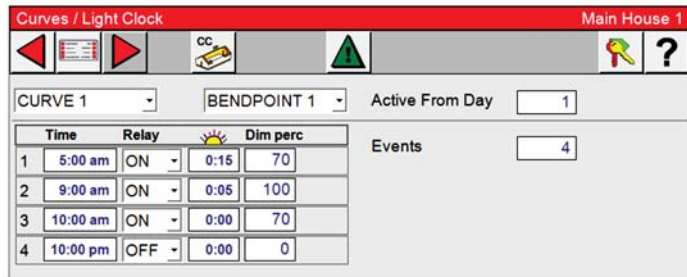

RunFor Clock Settings

1. Select the Main menu button.



2. Select the Curves Button.



3. Select the RunFor Clock button.



4. **Curves-** Four different curves can be setup. Select the curve you want to setup from the drop down. The curves are assigned to the Feed clock in the (Clocks/Feed/Feed Clocks) screen.

5. **Bend Point-** This is the current displayed bend point of the Light Clock Curve. Only one bend point can be shown at a time. Up to ten bend points can be used on each Curve. Select the Bend point you want to setup from the drop down.

6. **Active From Day-** This is the day that the current bend point will become the active light clock settings.

7. **Events-** A maximum of 24.

8. **On-at-** Enter the start time of the feeding in this column.

9. **Off-at-** Enter the off time of the feeding. This column allows the user to enter a time down to the second for operating feeders that only need to run for (mins. /sec or stimulations).

10. **Run-for-** Shows the amount of feeding time per Event.

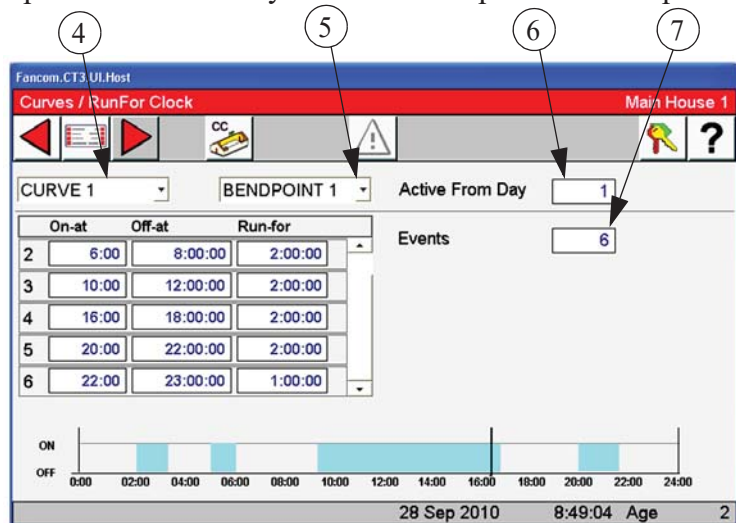

	On-at	Off-at	Run-for
1	5:00 am	5:20:30 am	0:20:30
2	6:30 am	6:50:30 am	0:20:30
3	8:00 am	8:00:30 am	0:00:30
4	10:00 am	10:20:30 am	0:20:30
5	2:00 pm	2:00:30 pm	0:00:30

Management Screens

Mortality Screen

1. Select the Main menu button.



2. Select the Management Button.

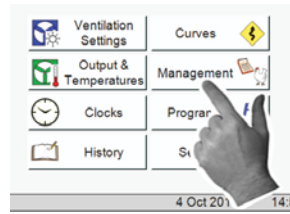

3. Select the Mortality button.



4. **Picked Up**- The number of dead and culled animals collected is entered on the Picked Up line. Select the Agreed button and the number(s) entered in the picked up line will be added to the Today and the Accum lines. The %Mort and the Curr (Current) Housed will be recalculated. The total daily mortality will also appear in the Daily History-Production screen.

5. **Agreed**- When the Agreed button is selected, the number(s) entered in the picked up line will be added to the Today and the Accum lines, the % Mort and the Curr (Current) Housed will be recalculated, and the total daily mortality will also appear in the Daily History-Production screen.

6. **Partial Taken Out**- This is used if live birds/animals are removed for any reason other than dead or culled.

7. **Initial Housed number**- must be entered first.

	Dead	Culled	Total
Picked Up	12	5	17
Today	0	0	0
Accumulated	0	0	0
Percentage	0.0	0.0	0.0
Initial Housed			25810
Partial Taken Out			0
Current Housed			25810
Total			

7. If Males and Females are being entered separately, use the tab buttons toggle between the Male, Female and Total Screens. When Male and Female Mortality is entered separately, the Total Mortality Screen is a summary of the Male and Female screens and is non-editable. See the Setup/House screen from the Main menu to tell the Control to keep track of Male and Female Mortality separately.

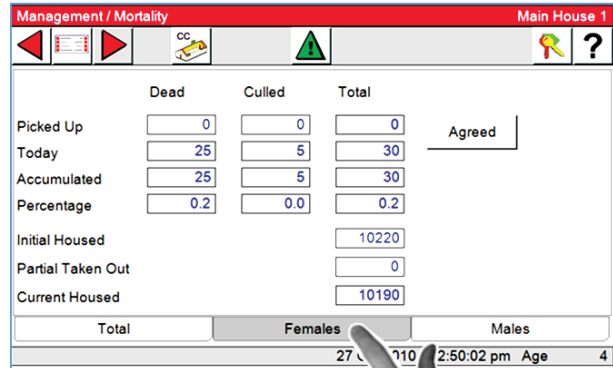
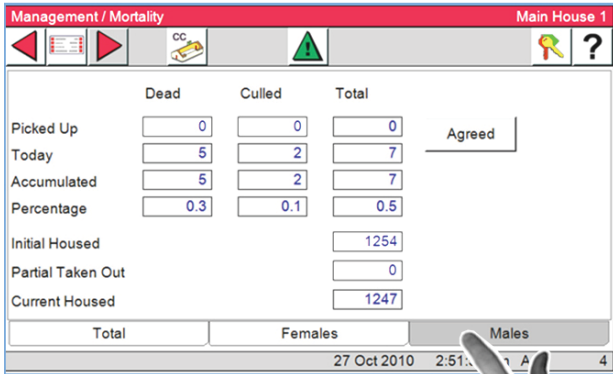
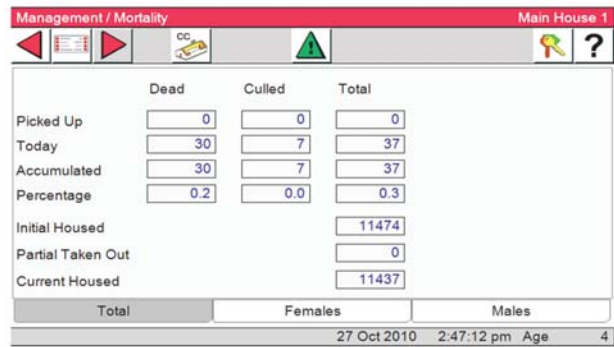

Water Screen

This screen will be available if a drinker line Water Meter is connected to the Control. This screen indicates the total water consumed in the house and how much water has been consumed in a certain period of time (for example, how much water was consumed in the house in the previous 5 minutes). If house mortality is being entered into the Control, then the total amount of water per 1000 birds (or per animal) will also be displayed.

1. Select the Main menu button.
2. Select the Management Button.
3. Select the Water button.



4. **Water Consumed Previous-** This number can be 1 to 60 minutes.
5. **Water Cumulative Per-** Select from drop down 1, 100 or 1000 birds.
6. **Water Today Per-** Select from drop down 1, 100 or 1000 birds.

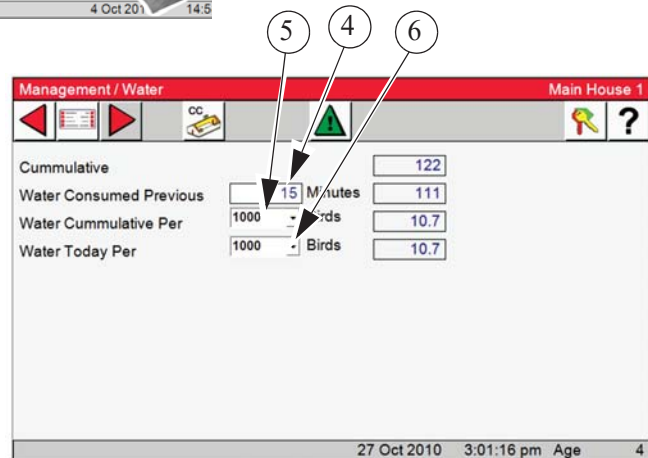

Flock Setup

1. Select the Main menu button.



3. Select the Flock button.



2. Select the Management Button.

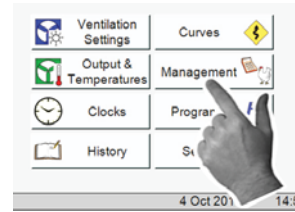

4. Select the Standard button.



5. **Growth Curve-** Enter the Growth curve for the type of bird you have. This can be entered by Day # or by Week # by selecting from the drop down in the "Use" box.

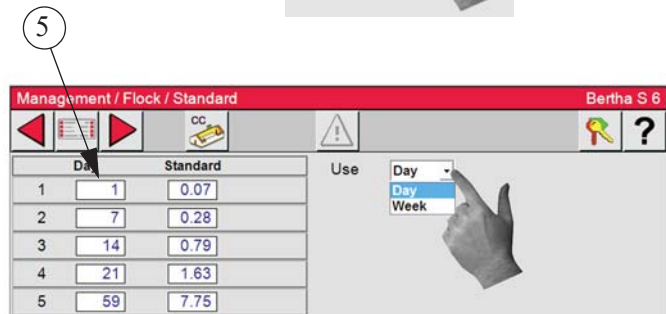

6. Click on the Back Button  and select "Info".



7. Select the Setup button.



8. Enter the Setup Day number. This example shows Day 2.

9. Enter the Flock number.

10. Enter Initial Weight.

11. Setup Date- Enter the current weight of the birds.

12. Click on Agreed when you are done.

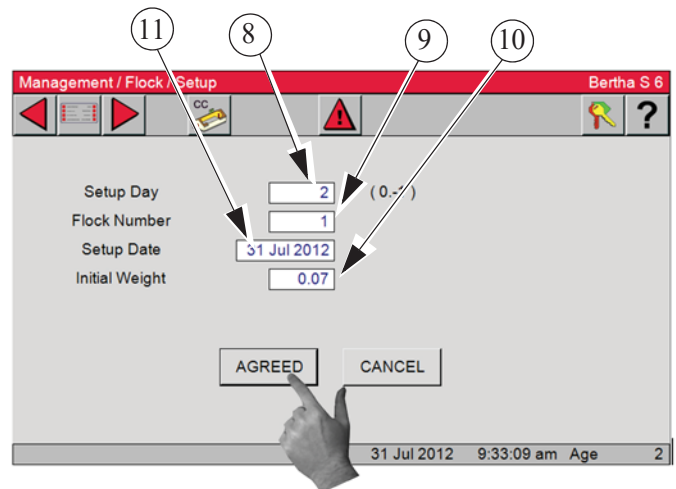

Flock Setup/Delivery

13. Select the Deliver Button.

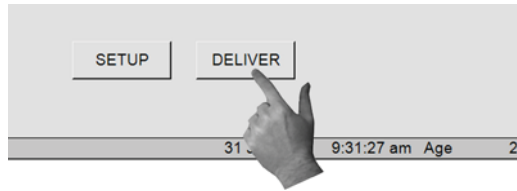

14. **Delivery Day** (Optional)

15. **Delivery weight**- The measured live weight in the slaughterhouse can differ from the wight readout on the CT3 Control. This difference in live weight can be caused by transport, animals having empty/full stomachs, differences in the house, etc. Using this option can correct the difference and take this correction into account during the next flock.

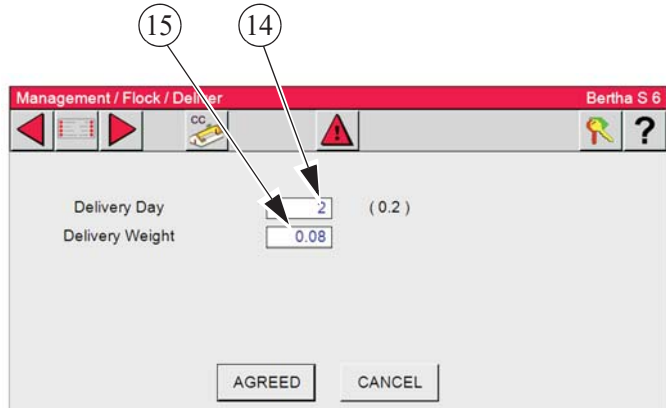

Flock Setup/Zero Calibration

1. Select the **Main menu** button.



2. Select the **Management** Button.

3. Select the **Flock** button.

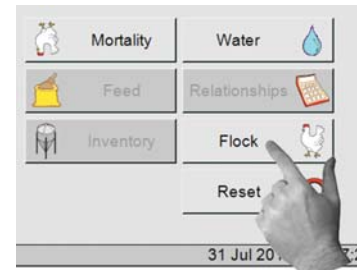
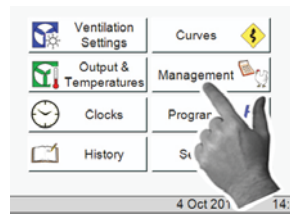

4. Select the **Zero Calibration** button.

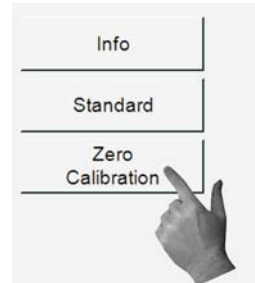

4. Calibrate- Ensure that the weighing scale is empty and select the **Calibrate** Button.

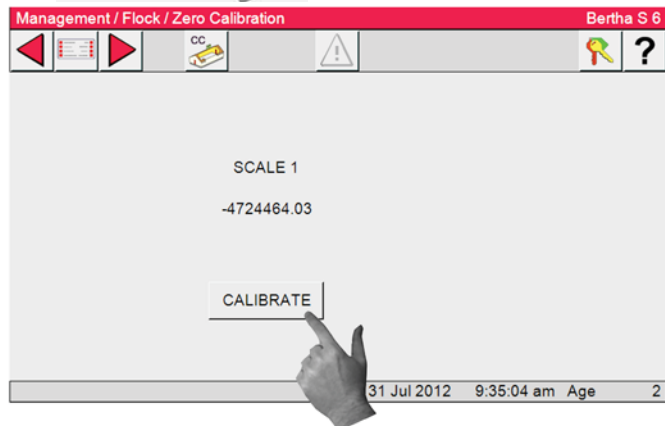

Management Reset Button

Selecting the Reset button from the Management screen will erase all management data.

Warning!! Once the Reset Button has been pressed it **can not** be reversed.

1. Select the **Main menu** button.
2. Select the Management Button.
3. Select the Reset button.
3. Select the "OK" button.

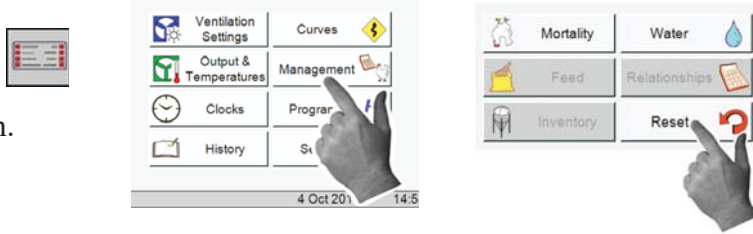

All History will be lost!!

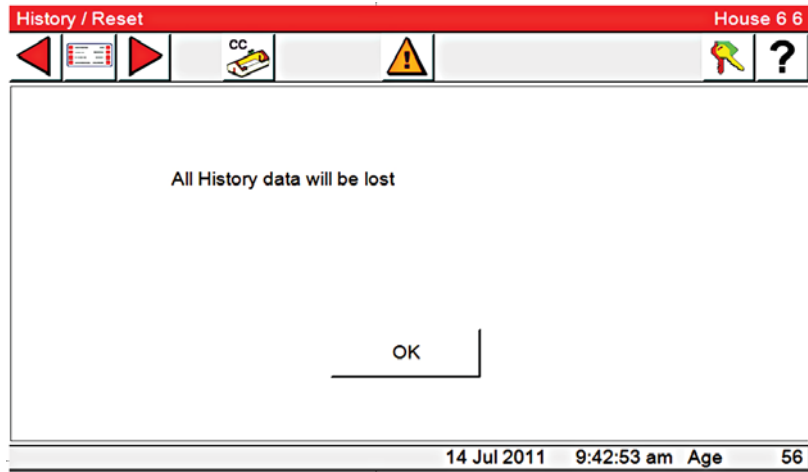

Programs/Setup Key Screens

Programs Screen/ Activate

1. Select the **Main menu** button. 
2. Select the **Programs** Button.
3. Select the **Programs** button.
4. In this screen you can choose from available **Programs** already programmed into the Control.



You then can choose an action for each program as follows: Activate Program Settings, Delete Program Settings, Save Program Settings, Yesterday's Settings. This is a very powerful screen that allows the user to store up to 6 complete setups of the Control that can be re-activated at any time.

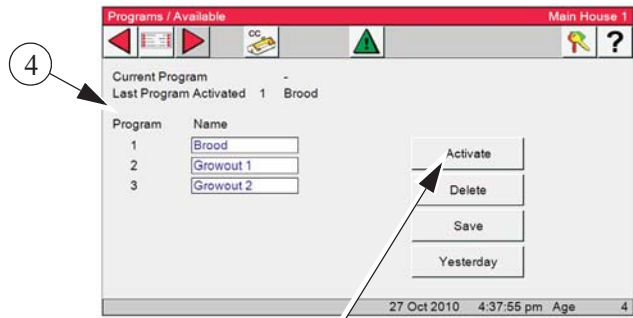

5. Select the **Activate button** from the Programs / Setup Key screen. The Programs / Activate screen will open.

6. Select the **desired saved program** from the drop down.

7. Select the **OK button**.

8. A window will open to ask you if you are sure you want to continue and that all control settings will be overwritten. **Select OK** to continue with the activation or **Cancel** to cancel the activation of the program.

9. If **OK is selected** the control will restart with all the selected program settings.

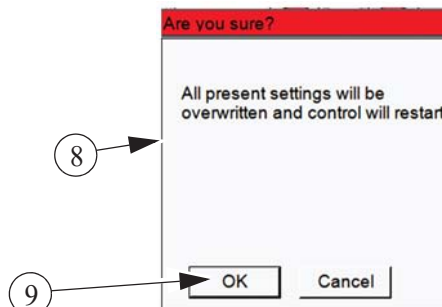
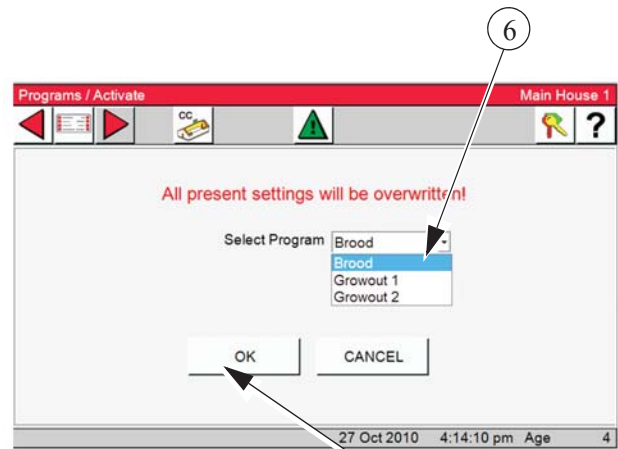

Programs Screen / Delete

1. Press the Programs Screen/ Programs Button



2. Programs Available- Choose from available Programs already programmed into the Control.

3. Choose **Delete** from action choices.

4. Select the **OK** button.

5. A window will open to ask you if you are sure you want to delete the selected program.

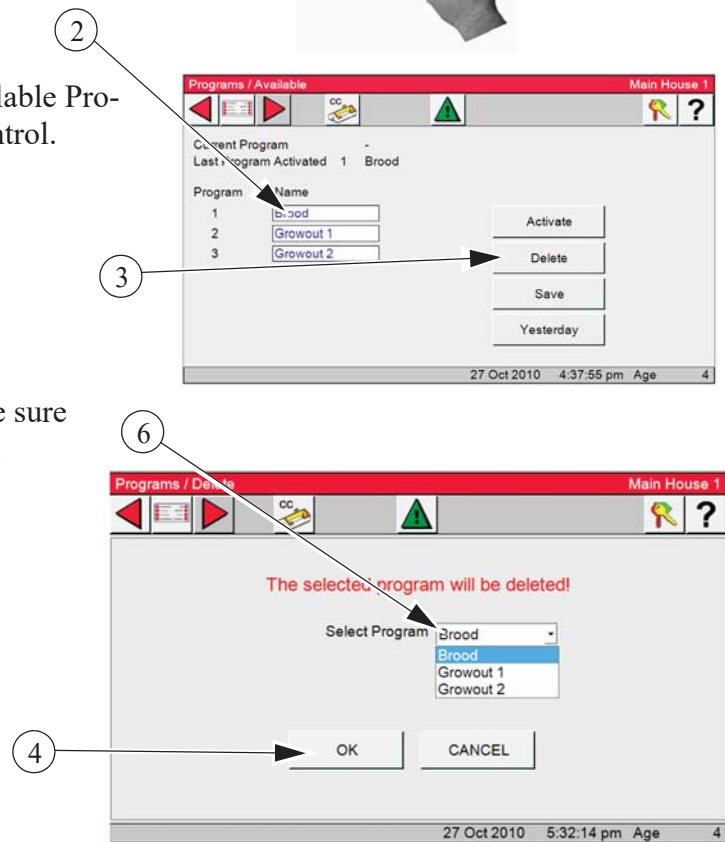

6. A window will open to ask you if you are sure you want to delete the selected program. **Select OK** to delete the program or **Cancel** to stop the operation.

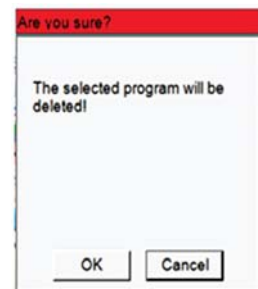

This **Does Not** delete the current setting in the Control, just the saved program.

In the Program / Available screen Program 1 (Brood) has been removed from the list.

Program Screen / Save

1. Press the Programs Screen/ Programs Button



2. **Programs Available-** Choose from available Programs already programmed into the Control.

3. Choose **Save** from action choices.

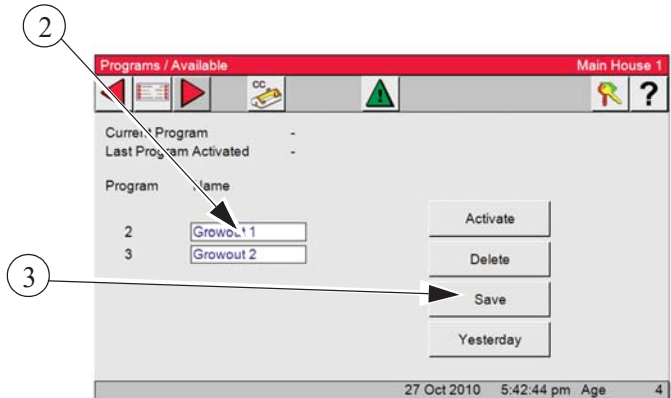

4. Select the **Program Number** from the drop down. 1 - 6

5. Enter the **Program Name**. Ten characters or less.

6. **Select OK** to Save the program or **Cancel** to stop the operation.

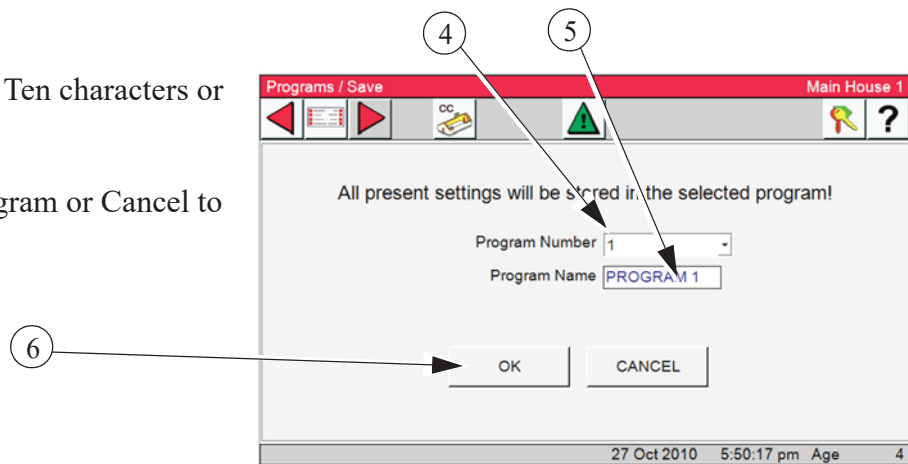

7. A confirmation window will open letting you know that all the present settings will be stored in the selected program. Select **OK** to Confirm or **Cancel** to stop the operation.

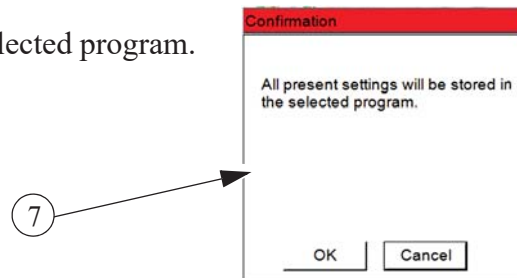

Programs / Yesterday

1. Press the Programs Screen/ Programs Button



2. Programs Available- Choose from available Programs already programmed into the Control.

3. Select Yesterday from action choices.

Every day at midnight, the settings of the Control is saved which can be activated anytime during the following day. This can be helpful if a mistake in setup is made and it is desired to undo the changes and go back to Yesterdays settings.

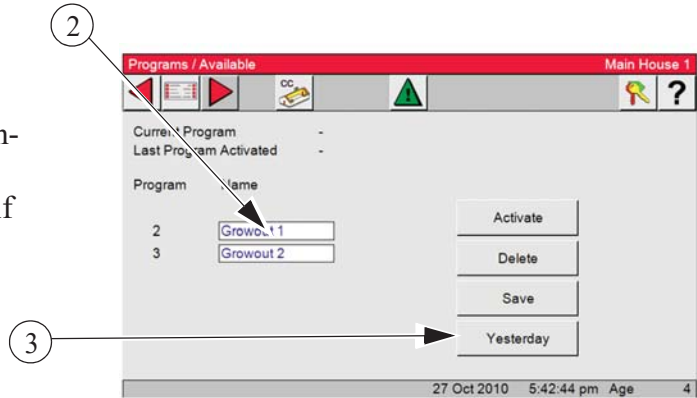

4. Select OK from the Program/Yesterday screen.

A window opens letting you know that all the present settings will be overwritten and the Control will restart.

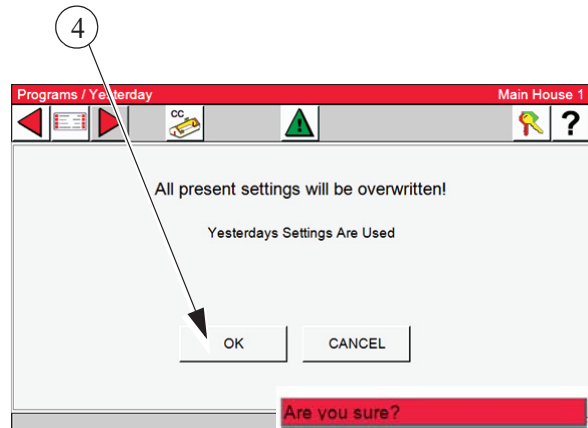

5. Select OK to confirm or cancel to stop the operation.

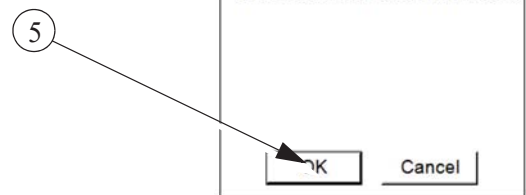

6. The Alarm will be sent two messages, Power Failure and Program "X" Activated. At this time notice the alarms and they will be sent to the Alarm history. These are not hard alarms.

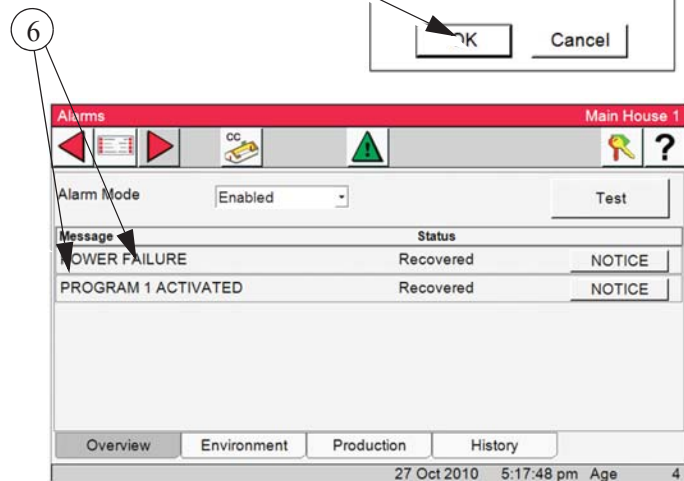

Setup Key Screen/ Activate

Insert a USB Flash Drive into the USB adaptor located on the lower left side of the main box. Unscrew the protective cap and plug-in the Flash Drive.



1. Select the **Programs** Button.

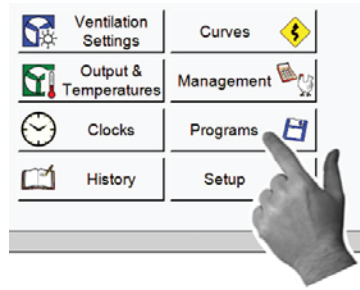

2. Select the **Setup Key** button. This screen is only available if a Setup Key (USB drive) is inserted in the USB plug located on the lower left side of the Control.

3. **Info Control**- The current software level operating on the Control.

4. **Info Setup Key**- The software level of the contents stored on the Setup Key. The software level stored on the Setup Key must match the current Control software level in order to transfer settings from the Setup Key to the Control.

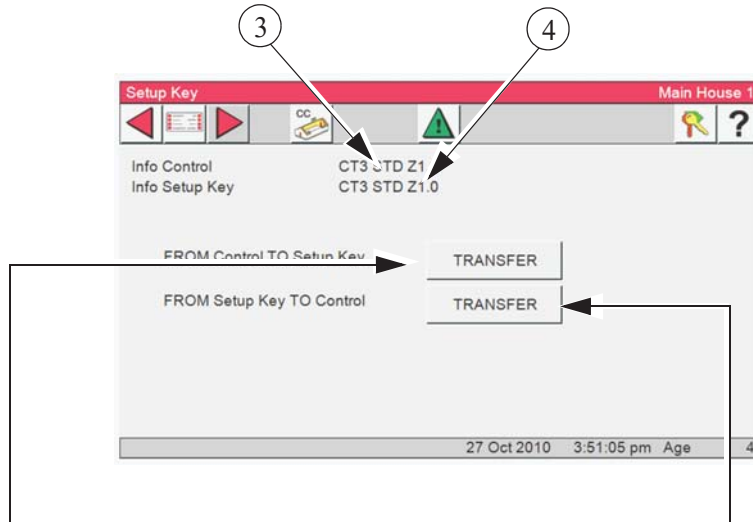

5. **Transfer FROM Control TO Setup Key**- Select the Transfer button to the left of Transfer FROM Control TO Setup Key to transfer all of the Controls settings to the setup key.

A dialog box with a red header 'Are you sure?'. The text inside reads: 'All present settings will be overwritten and control will restart!'. At the bottom are 'OK' and 'Cancel' buttons.

6. **Transfer From Setup Key to Control**- Select the Transfer button to the left of Transfer From Setup Key to Control to transfer the settings currently stored on the Control to the Setup Key.

A dialog box with a red header 'Are you sure?'. The text inside reads: 'All present settings will be overwritten and control will restart!'. At the bottom are 'OK' and 'Cancel' buttons.

The Alarm will be sent two messages, Power Failure and Program "x" Activated. At this time you should notice the alarms and they will be sent to the Alarm history. **These are not hard alarms.**

Clocks

The Clocks screen consists of the Current Light Clock, Current Feed Clock and Spare Clocks. The Lights and Feed Curves are assigned to their specific Clock in these screens.

1. Select the **Main menu** button. 
2. Select the **Clocks** Button.

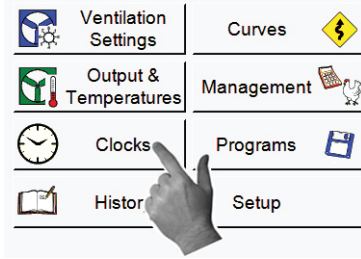

Light Clock

1. Select the **Light** button.

This screen displays all the Light Clocks assigned to relays and/or analog outputs. Each Light Clock button is assigned to a particular Light Clock.

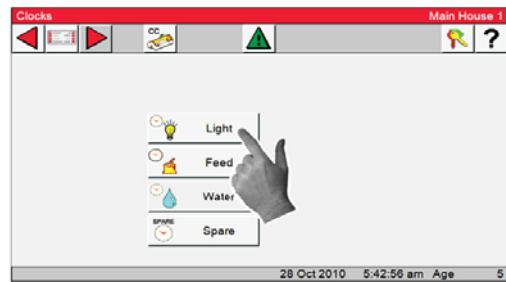

2. A **number or icon** is displayed to the left of the Light clock buttons.
3. If a Dimmer is used the current light level percent is displayed.

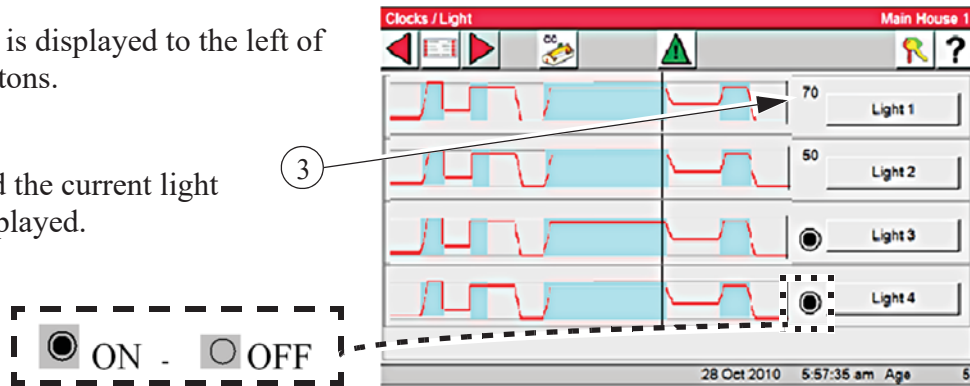

4. If no dimmer is used, the icon shows if the lights are On or Off.

5. To access the settings for each Light Clock press the desired Light Clock button. Press the **Light 1** button.

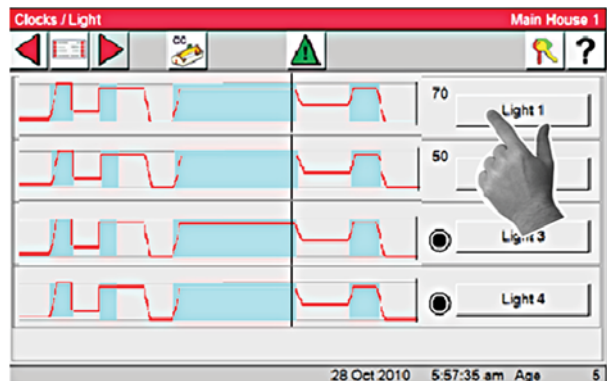

- 6. **Name Clock**- Is the current displayed clock.
- 7. **Events**- The current number of events that the Clock is using to control the lights.
- 8. **Use Curve**- selecting **On** or **Off** from the dropdown activates or deactivates the curve selected. If the light clock curve is set to **ON**, then the current light clock settings will **not** be **editable**. To temporarily change the current light clock settings, first set the curve to **OFF**, then make the desired changes. To return to the curve settings, change the curve back to ON.

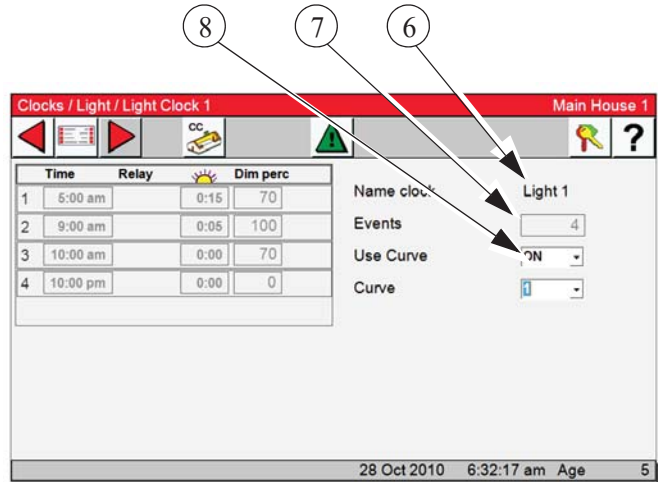

Light Clock Curve Set "ON"

	Time	Relay		Dim perc
1	5:00 am	ON	0:15	70
2	9:00 am	ON	0:05	100
3	10:00 am	ON	0:00	70
4	10:00 pm	OFF	0:00	0

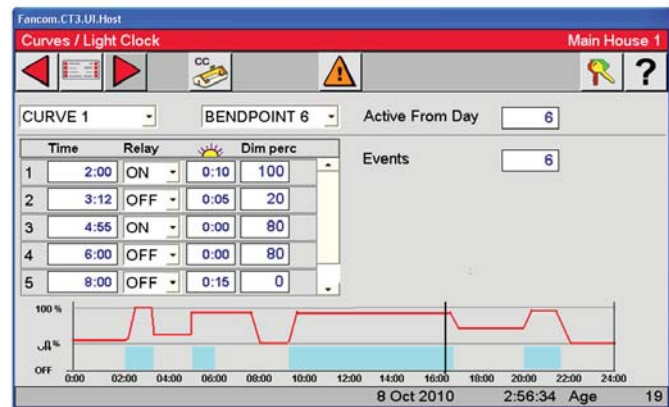

Light Clock Curve Set "OFF"

- 9. **Time**- Enter the time of day.
- 10. **Relay**: Turns the relay assigned to the Light clock that the curve has been assigned to on or off. This column will be blank if only an Analog output is assigned.

Feed Clock

1. Select the **Main menu** button.



2. Select the **Clocks** Button.

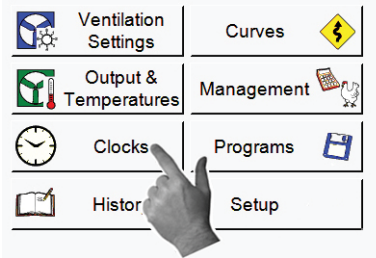

3. Select the **Feed** button.



4. This screen displays the Feed Clock settings link for the Feed clock.

5. The icon displayed to the left of the Feed button indicates if the feed output is on or off.

6. Selecting the Feed button will open Feed clock. Only one Feed clock is available.

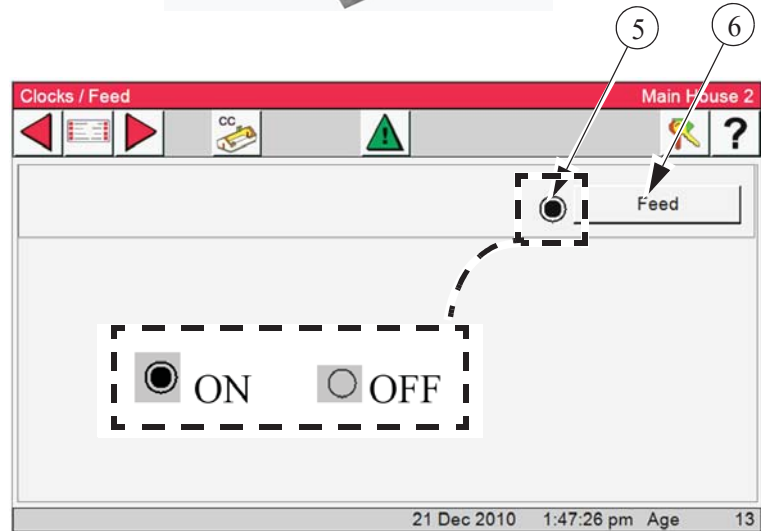

7. **Name Clock**- Is the current displayed clock.

8. **Events**- Is the current number of event the clock is using to control the Feeder.

9. **Use Curve**- selecting On or Off from the dropdown activates or deactivates the curve selected. If the Feed clock curve is set to ON, then the current Feed clock settings will not be editable. To temporarily change the current light clock settings, first set the curve to OFF, then make the desired changes.

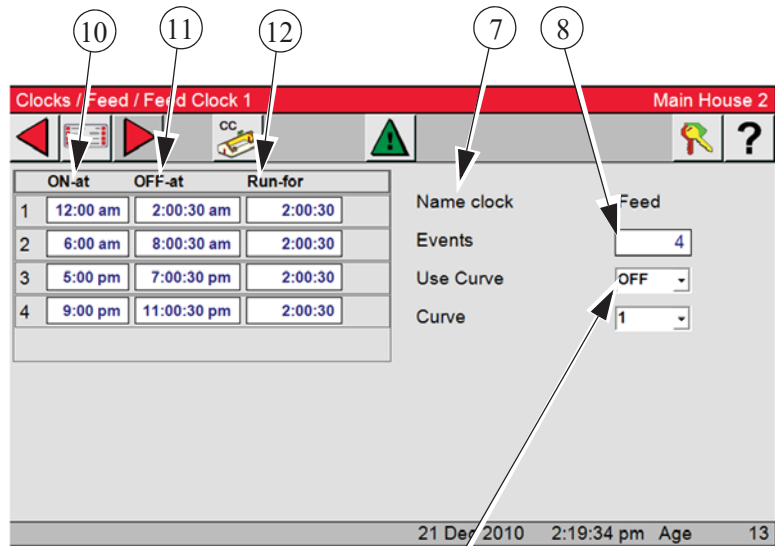

If the Use Curve is set to **OFF**, the Feed output will follow the settings displayed ever day until the Use Curve is set to ON then the output will follow whatever curve is selected.

10. **On-at**:- Enter the start time of the feeding in this column.

11. **Off-at**:- Enter the off time of the feeding. This column allow the user to enter a time down to the second for operating feeders that only need to run for (mins. /sec or stimulations).

12. **Run-for**:- Shows the amount of feeding time per Event.

Spare Clocks

1. Select the **Main menu** button. 

2. Select the **Clocks** Button.

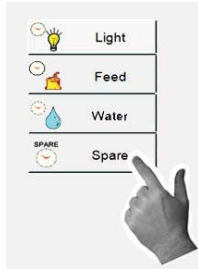

3. Select the **Spare** button.

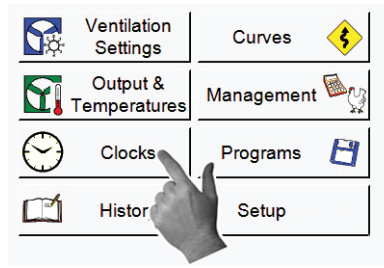

4. This screen displays the Spare Clock settings links for the Spare clock. Up to eight Spare clocks.

5. Use the slide bar on the right to display the other Spare clocks if more than four Spare clocks are in use.

6. The icon displayed to the left of the Feed button indicates if the Clock Output is on or off.

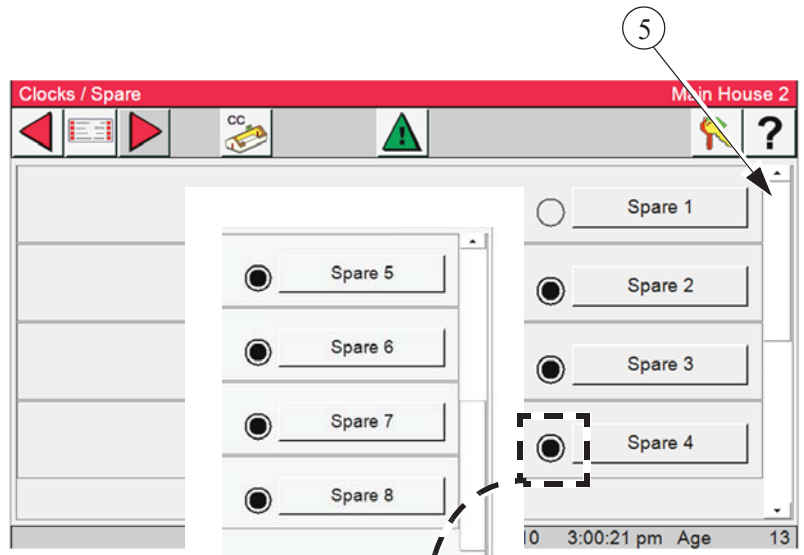

Spare Clock Setup- Example:

7. Select the Spare Clock you wish to set up. In the example shown we chose Spare Clock 1.

8. **Name Clock**- Is the current displayed clock.

9. **Events**- Is the current number of event the clock is using to control the Feeder.

10. **On-at**: Enter the start time of the feeding in this column.

11. **Off-at**: 11. Off-at: Enter the off time of the feeding. This column allows the user to enter a time accurate to the number of seconds.

12. **Run-for**: displays the amount of time per Event.

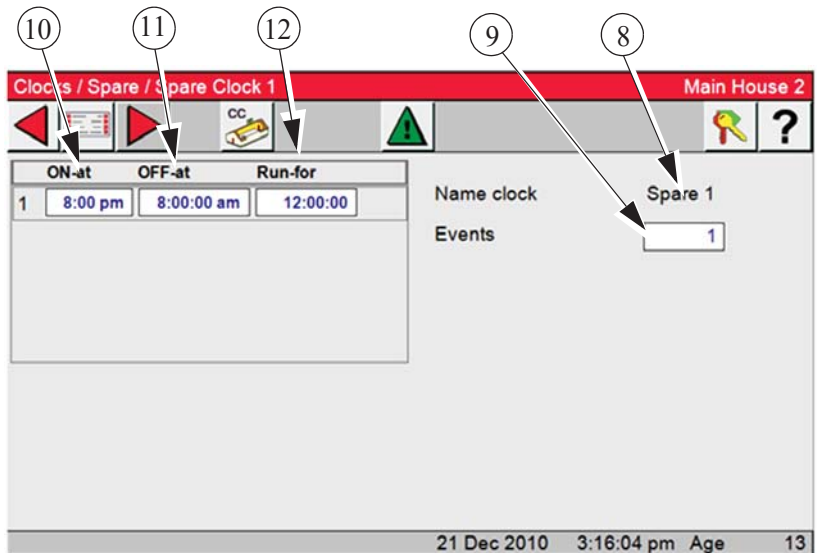

History

1. Select the **Main menu** button.
2. Select the History button.

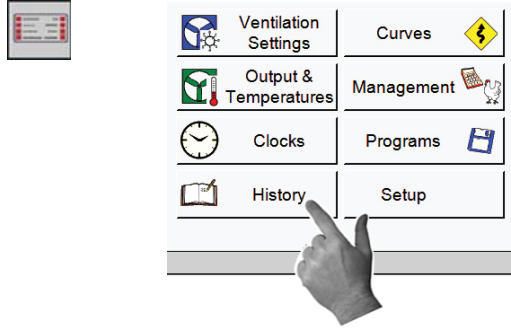

History-Environment

1. Select the Environment button.

<u>History</u>	<u>Number of days.</u>
Mode Temperature	100 days
Sensors (all assigned)	14 days
Humidity House	14 days
Heat Run Times	14 days

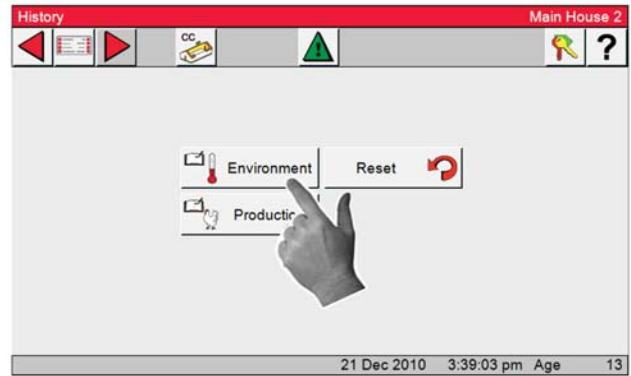

2. Select one of the tab buttons along the bottom to view that Tab's History.

Note: Tabs that are grayed out have no history because no sensor has been installed.

3. Press the **Mode Temperature Tab**
4. Use the slide bar on the right to move history up and down.

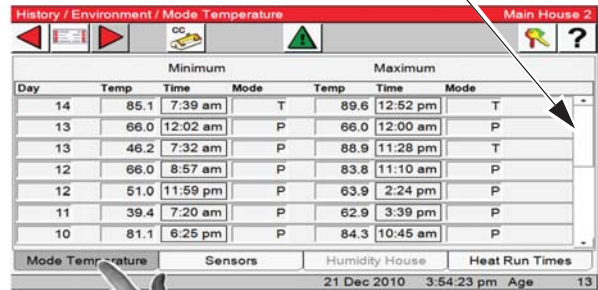

5. Press the **Sensors Tab**
Some of the history selections have more than one sensor. To select a Sensor, use the drop down as shown to the right.

Environment

Code	Number of days.
Water	14 days
Feed	14 days
Mortality	100 days
Auxiliary	14 days
Feed Lines	14 days

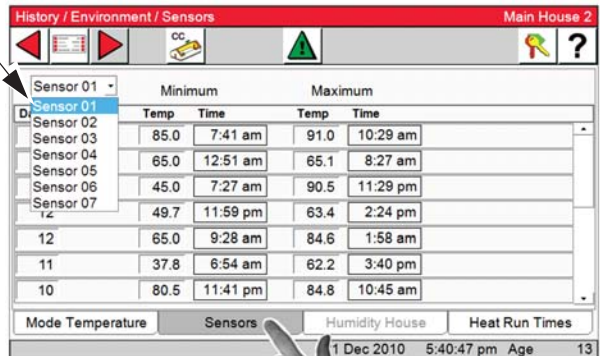

History-Production

1. Select the **Main menu** button.



2. Select the **History** button.



3. Select the **Production** button.

4. To view production history for; Water, Feed, Mortality, Auxiliary, or Feed line, select the Tab at the appropriate Tab at the bottom of the screen. Water History has been selected in the example.

5. Use the Slide Bar at the right of the screen to scroll through the history.

Some of the history selections have more than one sensor. To view select the sensors from the drop down in the upper left of the screen.

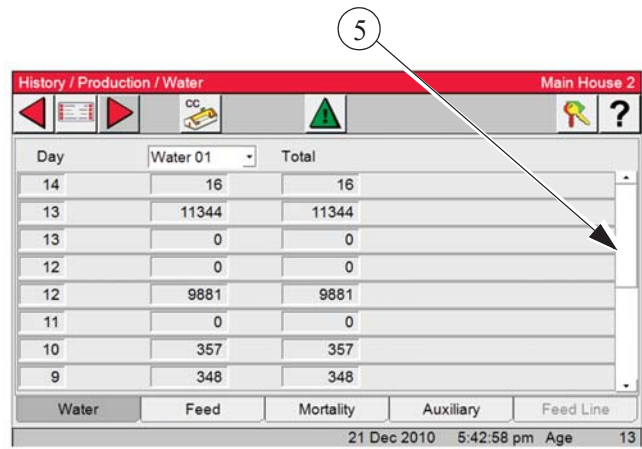
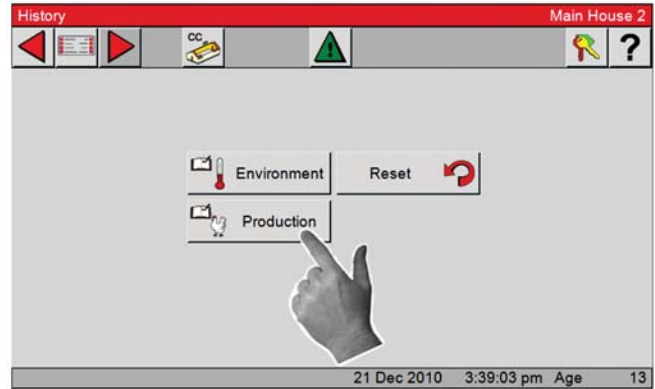

History-Reset

1. Select the **Main menu** button.



2. Select the **History** button.



3. Select the **Reset** button.

4. If "OK" is selected, **all History will be lost.**

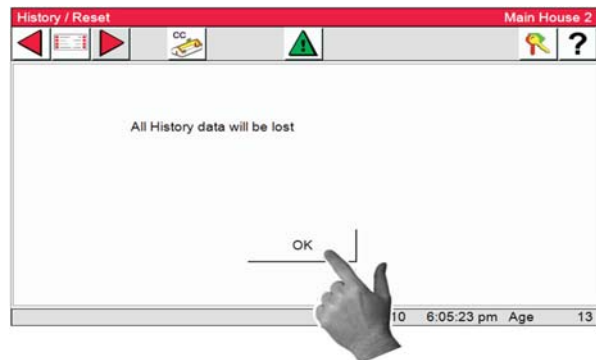
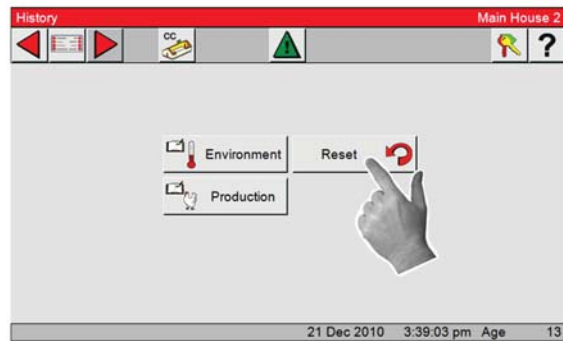

Setting up Sidewall Inlets

1. Select the **Main menu** button.
2. Select the Setup button.

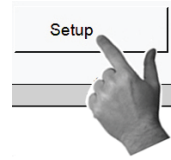

3. Select the **Outputs** button.
4. Select the Equipped/Numbers button.

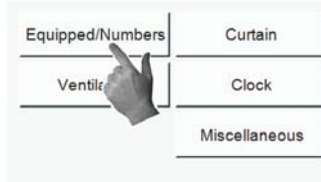
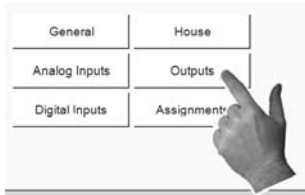

5. Select both the Sidewall inlets and Ceiling inlets check boxes. The number 1 will appear in the box to the right. This shows that at least one pair of relays are to be used. (Open/Close)

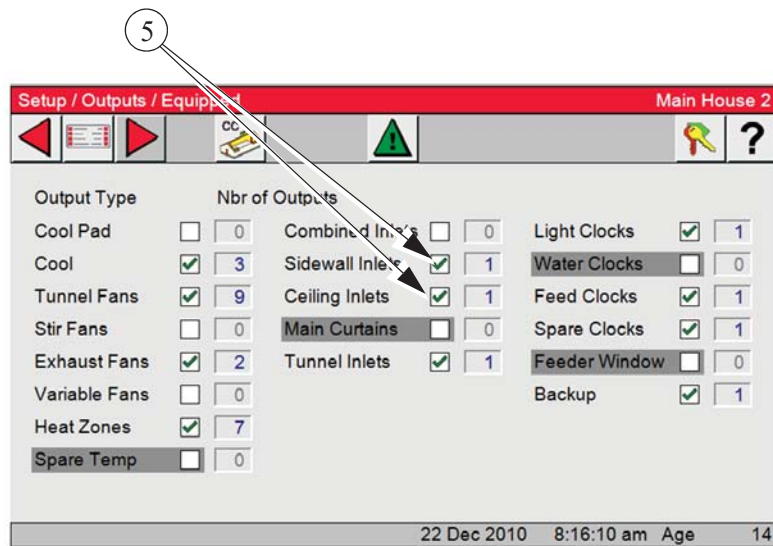

6. Select the Back button  to return to the Outputs Screen.

7. Select the Curtain button



8. Select the Sidewall Inlet button.

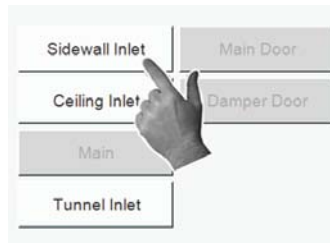

9. In the Setup/Outputs/Curtain/Sidewall inlet screen select the relays that are to be assigned to the Sidewall inlets. Select the Open relay from the drop down and the Close relay will be assigned by the control. Only two sets of (Open/Close) relays can be assigned. External relays must be used if there are more than two machines. Both sets of relays are operated at the same time.

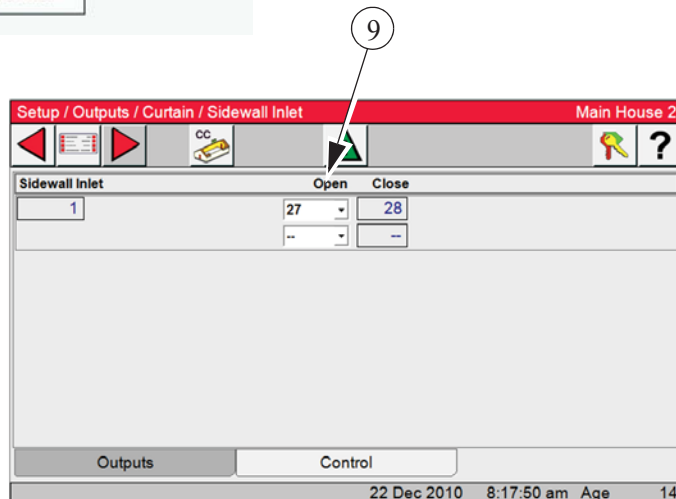

10. Select the Control Tab at the bottom of the screen.



11. **Inlet Anticipation**- Select from the drop down Calculated or Fixed.

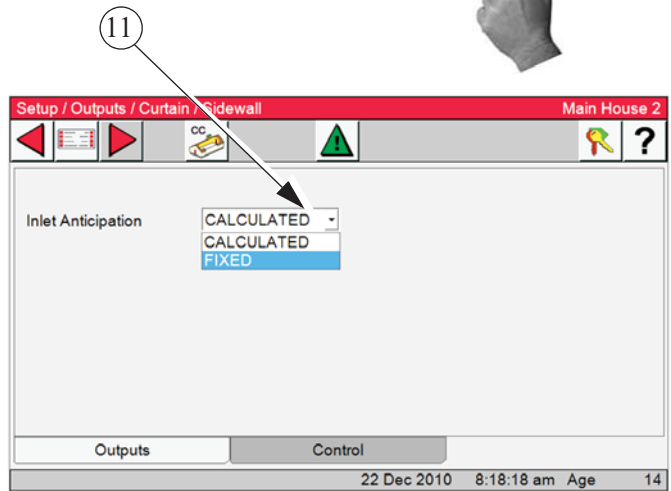

11a. If **Fixed anticipation** is chosen fill in the amount of time in seconds you want the inlets to anticipate.

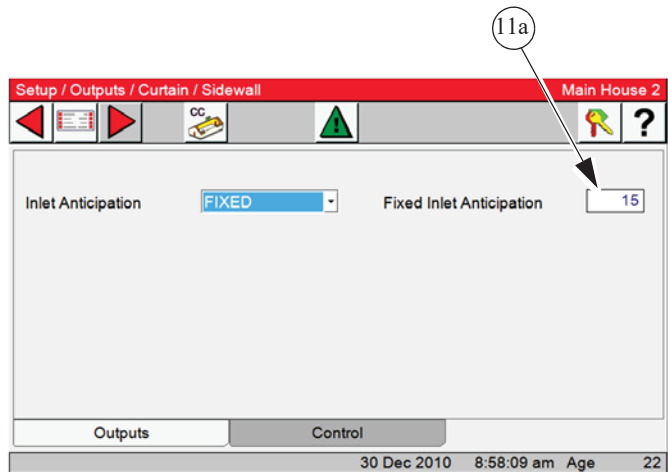

Setting up Ceiling Inlets

If continuing to setup Ceiling Inlets from the Sidewall screen above, select the Back button  twice to return to the Setup/Outputs/Curtain Screen.

1. Select the **Main menu** button. 

2. Select the Setup button. 

3. Select the **Outputs** button. 

4. Select the Ceiling Inlet button. 

5. In the Setup/Outputs/Curtain/Ceiling Inlet screen select the relays that are to be assigned to the Ceiling inlets. Select the Open relay from the drop down and the Close relay will be assigned by the control. Only two sets of (Open/Close) relays can be assigned. External relays must be used if more than two machines are installed. Both sets of relays are operated at the same time.

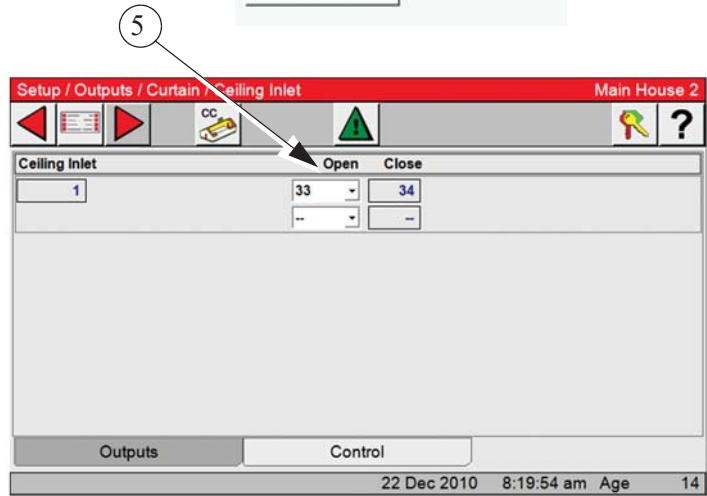

Continue Setup of the Attic Inlet by selecting the Control Tab...

6. **Use Attic Air Sensors-** Choose the inside sensor (s) you want to use as controlling sensors.

7. **Inlet Anticipation-** Select from the drop down Calculated or Fixed.

8. **Controlled By-** Select from the dropdown SP (Controlled by static pressure or Gravity) If Gravity is selected the Inlet anticipation Fix or Calculated will have no effect.

9. **Allow Attic Air From-** Enter the time of day you want to use the attic

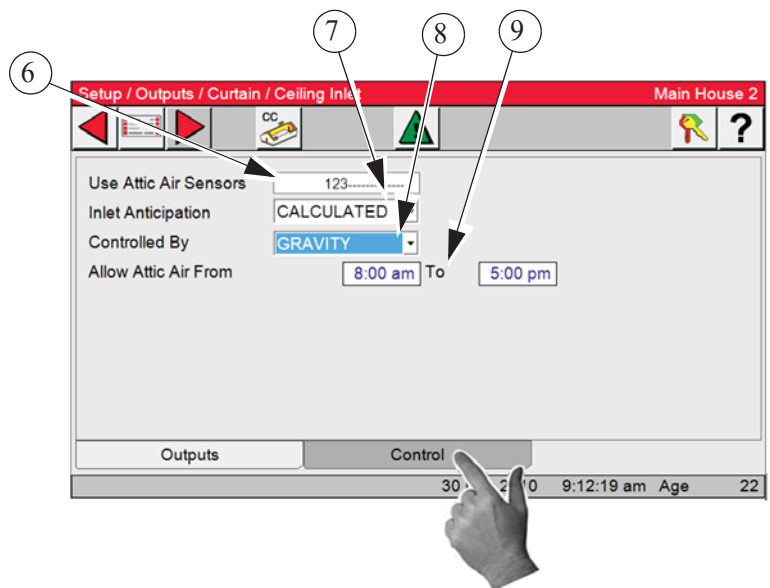

Setting up Ceiling Inlet Parameters

Setting the parameters for the Ceiling Inlet is done in the Outputs and Temperature screen.

1. Select the **Main menu** button. 
2. Select the **Outputs and Temperature** button.
3. In the output column you will see "Use Attic Air output".
4. To the left are an ON and Off temperature.

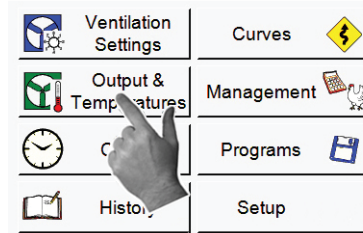

Example:

- a) On temp of 84.2. All the air will come from the attic if the temperature of the sensor(s) assigned to the Ceiling inlet is at or below the on temperature.
- b) if the temperature of the sensor(s) assigned to the Ceiling inlet is above the on temperature but at or below the Off temp of 85.2. and the static pressure stays above the high setting for one minute the Side wall inlets will open to maintain the correct static pressure and allow the mixing of attic and outside air.
- c) If the temperature of the sensor(s) assigned to the Ceiling inlet is above the Off temperature the Ceiling inlet will close. The Sidewall inlets may open or close to maintain the correct static pressure.
- d) If the temperature drops below the ON temp the Sidewall inlets will close and the Ceiling inlets will open to maintain static pressure. If the static pressure is above the high setting the Sidewall inlets will open to maintain the correct pressure.

The screenshot shows the 'Outputs and Temperatures' screen for 'Main House 2'. The screen displays a table with columns for 'On', 'Off', 'Output', 'T-Avg', and 'Timer'. Callouts 'a', 'b', and '3' point to specific values in the 'On' and 'Off' columns.

On	Off	Output	T-Avg	Timer
88.2	85.9	Tunnel Fan 4	66.0	--
86.7	84.4	Tunnel Fan 3	66.0	--
85.2	82.9	Tunnel Fan 2	66.0	--
84.2	82.4	Exhaust Fan 1	66.0	--
84.2	85.2	Use Attic Air	64.0	
83.7	82.2	Exhaust Fan 2	66.0	--
83.2	82.2	Tunnel Fan 1	66.0	MIN VENT
82.2		Set Temperature	66.0	
0.0	0.0		0.0	

Callout 'a' points to the 'On' value 84.2 in the 'Use Attic Air' row.
 Callout 'b' points to the 'Off' value 85.2 in the 'Use Attic Air' row.
 Callout '3' points to the 'Off' value 82.4 in the 'Exhaust Fan 1' row.

User Levels

1. Select the User Level button, select Admin from the list.

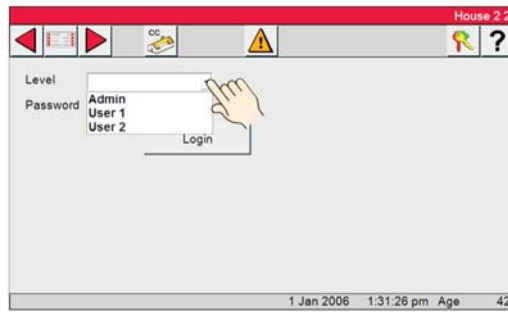
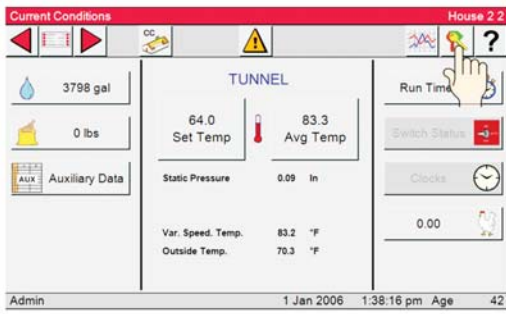

2. Enter Password and Select Login

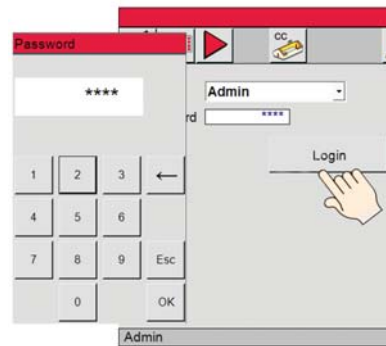
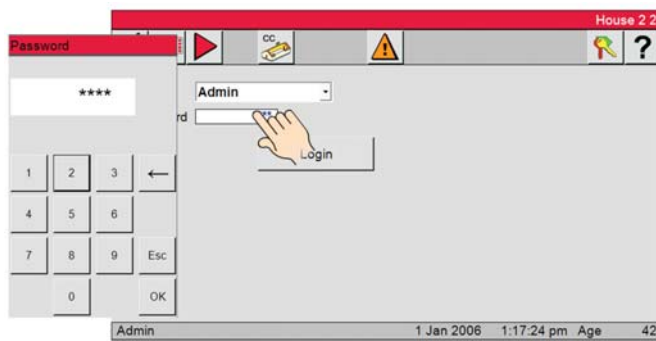

3. Select Admin



4. Back space, then enter a new 4 number password.

Select OK.

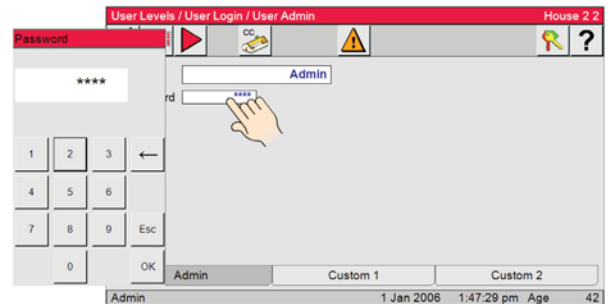

5. Select Current Conditions, Main Menu, or the Alarm Button to exit User Levels

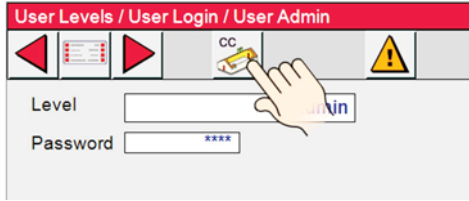

6. Log in after 5 minutes or after Logout.

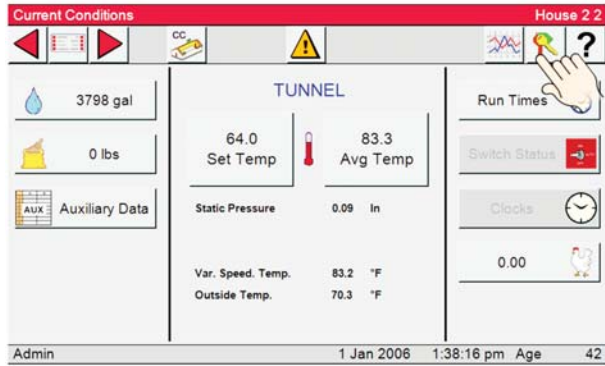

7. Select Admin from the dropdown or one of the Users if a User has been setup.

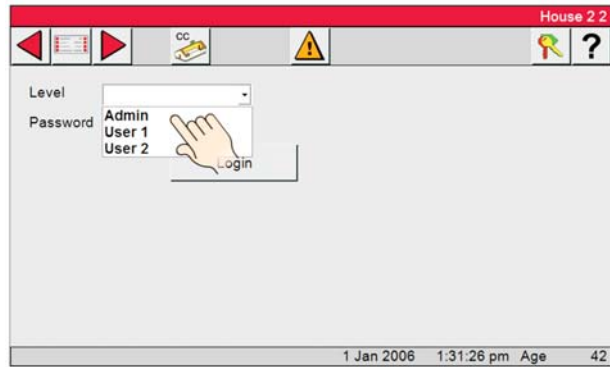

8. Select in the Password box and enter your Password, Select OK, and then Select Login.

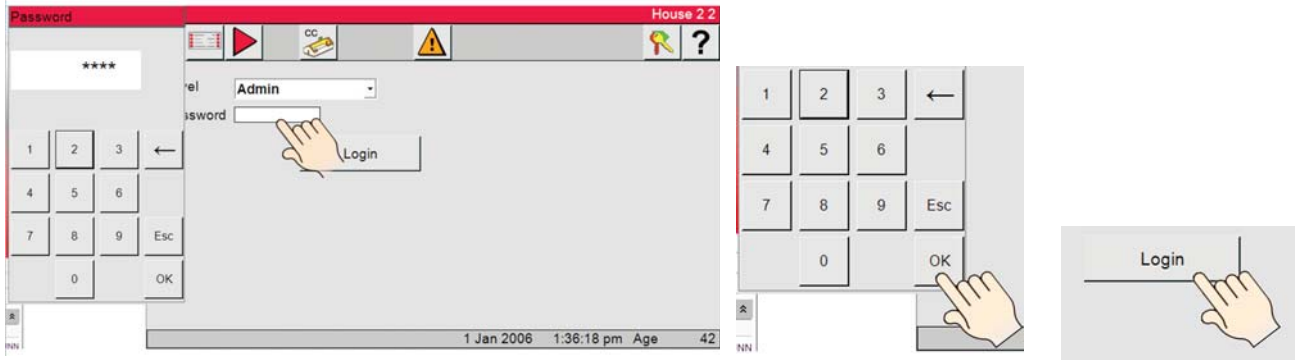

After making all of the desired changes, you can Logout. All Users will have to Login to make changes.



9. Screens after Admin Logout if Users 1 and 2 settings at default. All editable fields are grayed out.

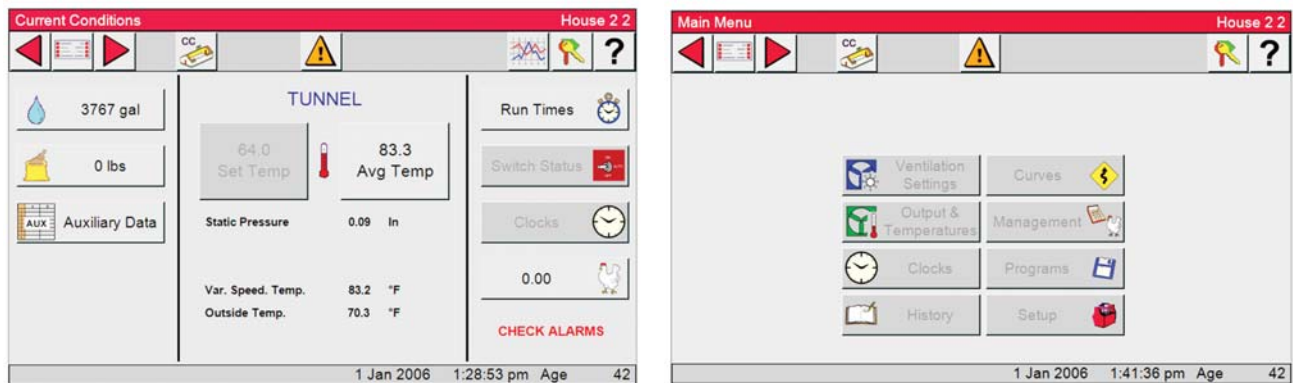

Setting up Custom User Levels

1. Select the User Level Button.

2. Select the Admin Button.

3. Select Custom 1 or Custom 2.

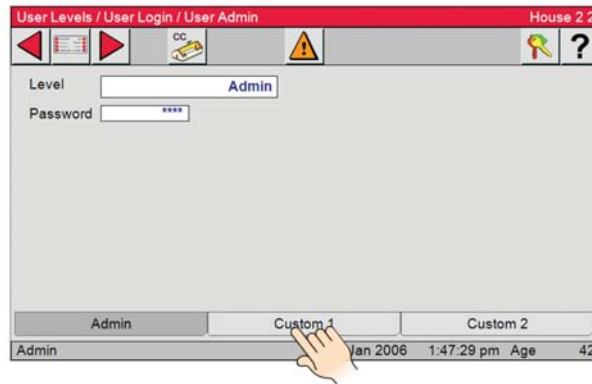

4. From this screen you can edit the User Name, Password, or select which screens can be edited or viewed. Only the Admin can make changes to the User Levels.

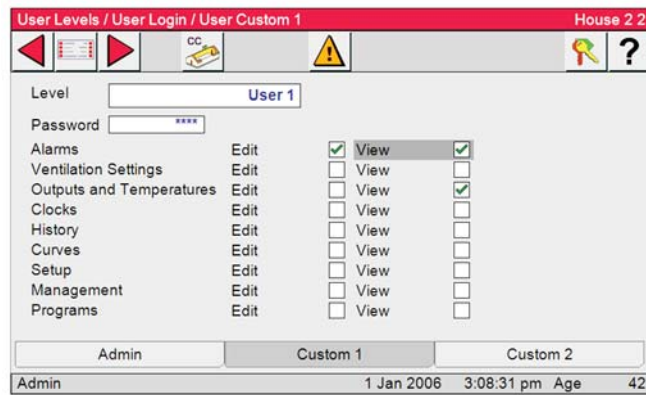

Note: You must Login as the Admin to setup User Levels.

Control Operation Overview

Standard Mode Functionality

Power Mode

All curtain(s) are given a continuous close signal. Inlets are controlled by static pressure (if used). All outputs that are allowed to operate in Power Mode turn on and off per screen 4 trying satisfy their sensors assigned in Screen 13.

Natural Mode

Main Curtain Range- The Main curtain range is defined in the Outputs and Temperature screen (Screen 4) and has a default setting of + or - 1.5 degrees F of the set temperature. Once the Control has made the full transition from Power to Natural mode (or Tunnel to Natural), each main curtain's control sensor will either open or close the main curtain(s) to try to keep the sensor's temperature within the Main curtain range. If the curtain's control sensor temperature goes above the range then the curtain will open. If the curtain's control sensor temperature goes below the range then the curtain will close. The amount the curtain moves is based upon how far the curtain's control sensor(s) is from the AVERAGE of the Main curtain range. If the curtain's control sensor(s) goes more than 8 degrees F ABOVE the AVERAGE of the Main curtain range, the curtains will be given a continuous open signal until the temperature returns to within the Main curtain range. If the curtain's control sensor(s) goes more than 8 degrees F BELOW the AVERAGE of the Main curtain range the curtains will be given a continuous close signal until the temperature returns to within the Main curtain range or until the Control returns to Power Mode. The control returns to power mode when the main curtain(s) reach the first opening position (see Natural to Power Mode transition).

Time Between Curtain Movements

The Time between curtain movements is the amount of time the control will wait after an opening or closing of the main curtain(s) before checking the temperature again and doing another open or close movement. The default time between curtain movements is 2 minutes. The amount time between curtain movements can be set between 1 minute and 5 minutes. The time between curtain movements is set in Screen 14, Curtains tab.

Rate of Curtain Movement

The Rate of Curtain Movement is the amount the control will either open or close the curtain(s) during a curtain movement. The actual amount of curtain movement is calculated by taking the Rate of curtain movement and multiplying by the number of degrees the curtains control sensor is from the AVERAGE of the Main Curtain Range. For example, if the Rate of curtain movement is 1.2 inches per degree F, the AVERAGE of the Main Curtain Range is 74.0 degrees F and the curtains control sensor is reading 76.0 degrees F then the control will open the curtain 2.4 inches ($1.2 \times [76-74]$). The default Rate of Curtain Movement is 1.2 inches per degree F and can be set between 1 in and 4 inches per degree F. The rate of curtain movement is set in Screen 14, curtains tab.

All Outputs that are allowed to operate in Natural Mode turn on and off per the Outputs and Temperatures screen (Screen 4) trying to satisfy their sensors assigned in the Setup-General screen.

Control Installation

Mounting the Control

56 Output Control Mounting

A 56 Output Chore-Tronics® 3 Control consists of a Main Box and a Relay Box. The Main Box requires a minimum mounting area of 21 in. [53 cm] x 21 in. [53 cm] (See Figure below). The Relay Box requires 22 in. [56 cm] x 27 in. [69 cm]. This dimension allows extra room for the control doors to open. The boxes should be mounted level and square on a solid backing using the mounting holes provided.

Note: When mounting the Main Box and the Relay Box, make sure the two boxes are as close together as possible to reduce the likely hood of a communication failure. Make sure that the Relay Box is mounted so that the relay indicator lights are visible when standing at the Main Box.

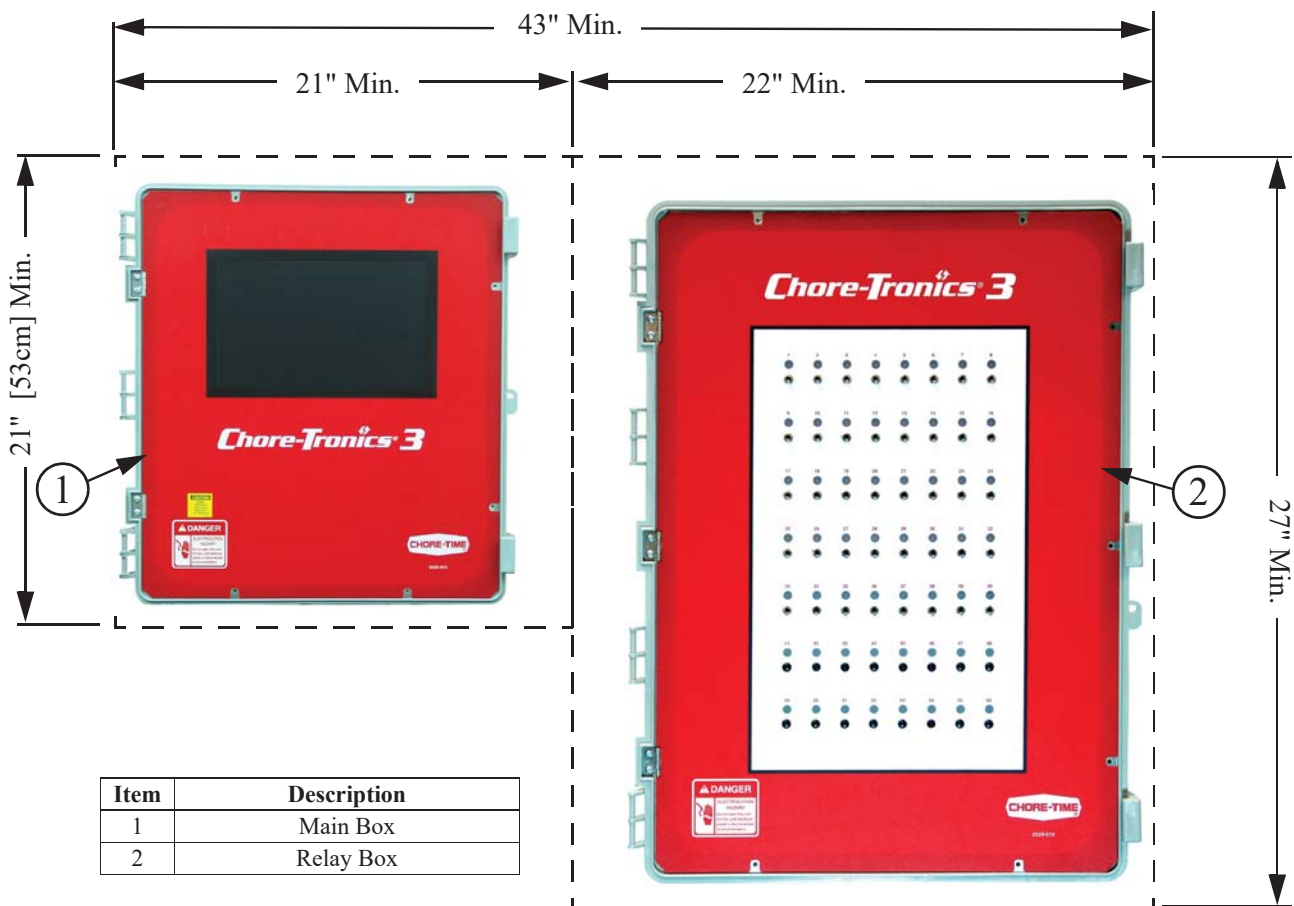

Figure 11. 56 Output Control Mounting

Warning! Do Not run I/O Net or 24 Vdc Twisted Pair wire close to and/or parallel with line voltage wires. (See Figure 75)

The I/O Net terminals of the Main Box and the Relay box must be connected together using the Non-Shielded Twisted Pair Wire (Chore Time Part no. 42208) included within the Main Box. There is a Decal (Figure 11, Item 4) on the Main Box as well as the Relay Box showing the location to route the I/O Net wires (Communication Wires). I/O Net is polarity sensitive so be sure that the positive and negative I/O Net terminals of both the Main Box and the Relay Box are connected properly (See Figure 12). Make sure that the Jumper on the I/O Board is in the ON position (See below). The 24 Vdc must also be connected from the Main Box to the Relay Box using the Twisted Pair wire included within the Main Box. Route the wires along with the I/O Net Wires according to the Communication Wire Decals (Item 4) on the Boxes.

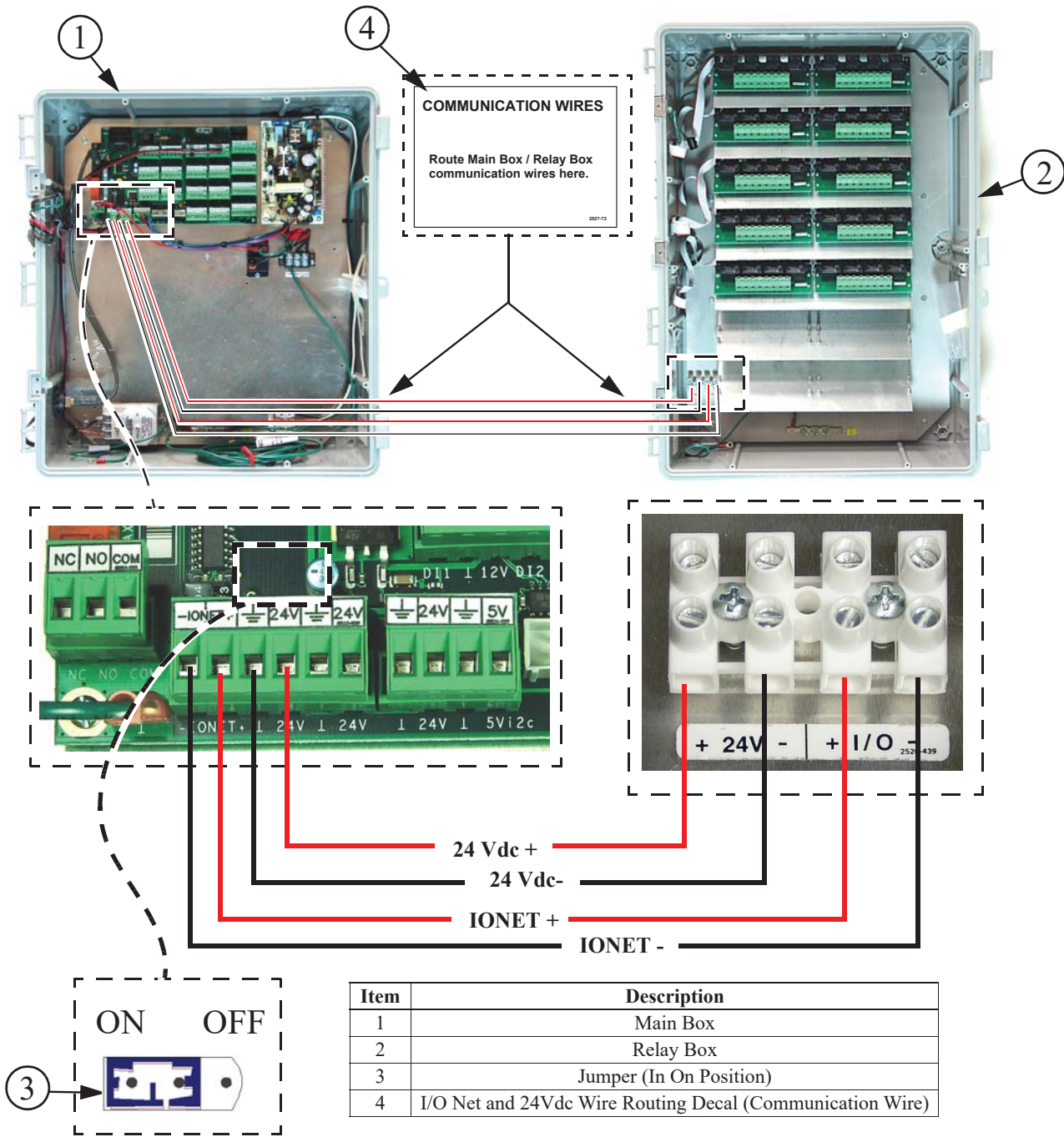

Figure 12. I/O Net and 24Vdc Wiring (Communication Wire)

Caution: Do NOT run 24 Vdc and I/O Net wire close to and/or parallel with line (120 Vac or greater) voltage wires. Doing so can cause operational failure in the Control and will void Warranty. If 24 Vdc or I/O Net wires need to cross line voltage wires make sure the wires cross at a 90 degree angle. Also, no other electrical devices such as transformers, light dimmers, additional relays, etc. should be mounted inside the Main Box or near the 24 Vdc power or I/O Net wires.

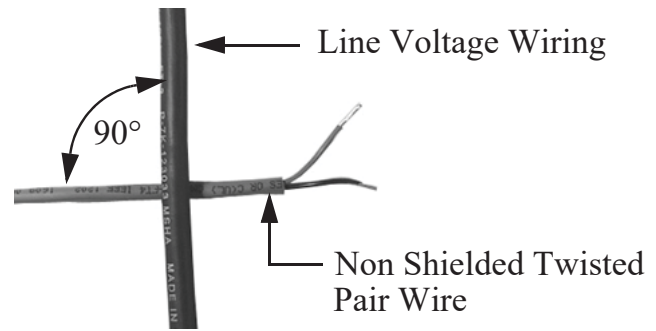
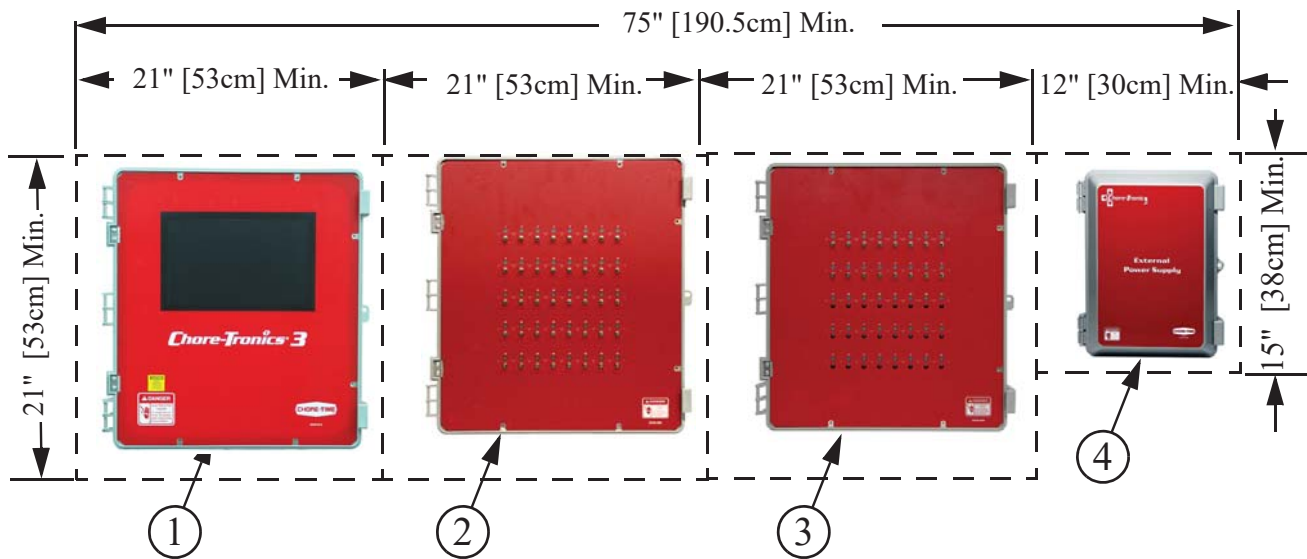

Figure 13. 90° Crossover

56 Output Controls

A 56 Output Chore-Tronics® 3 Control consists of a Main Box, *two* Relay Boxes, and an External Power Supply for the Second Relay Box. The Main Box and the Relay Box/s Each require a space of 21 in. [53 cm] x 21 in. [53 cm]. The External Power Supply requires 12" [30cm] x 15" [38cm]. These dimensions allow extra room for the Control doors to open. The boxes should be mounted level and square on a solid backing using the mounting holes provided.

Note: When mounting the Main Box and the two Relay Boxes, make sure that the boxes are mounted as close together as possible to reduce the likely hood of a communication failure. Make sure that the Relay Boxes are mounted so that the relay indicator lights are visible when standing at the Main Box. (See Figure 14)



Item	Description
1	Main Box
2	Relay Box
3	2nd Relay Box
4	External Power Supply

Figure 14. 56 Output Control Mounting

The I/O Net terminals of the Main box and the two Relay Boxes must be connected using Non-shielded Twisted Pair Wire (Chore-Time part no. 42208). Using the Twisted Pair Wire provided, hook the I/O Net wires from the first Relay Box to the Main Box, then from the Main Box to the Second Relay Box. I/O Net is polarity sensitive so be sure that the positive and negative I/O Net terminals in all boxes are connected properly (Figure 15). Also make sure that DIP switch #1 on the IO board of the Main Box is in the OFF position. 24 Vdc must be connected from the Main Box to the first Relay Box (relays 1-40) using the Twisted Pair Wire provided. The 24 Vdc for the Second Relay Box (relays 41-56) must be connected to the External Power Supply (See Figure 15).

Important! The supply voltage for the External Power Supply needs to come from the same breaker as the Main Box.

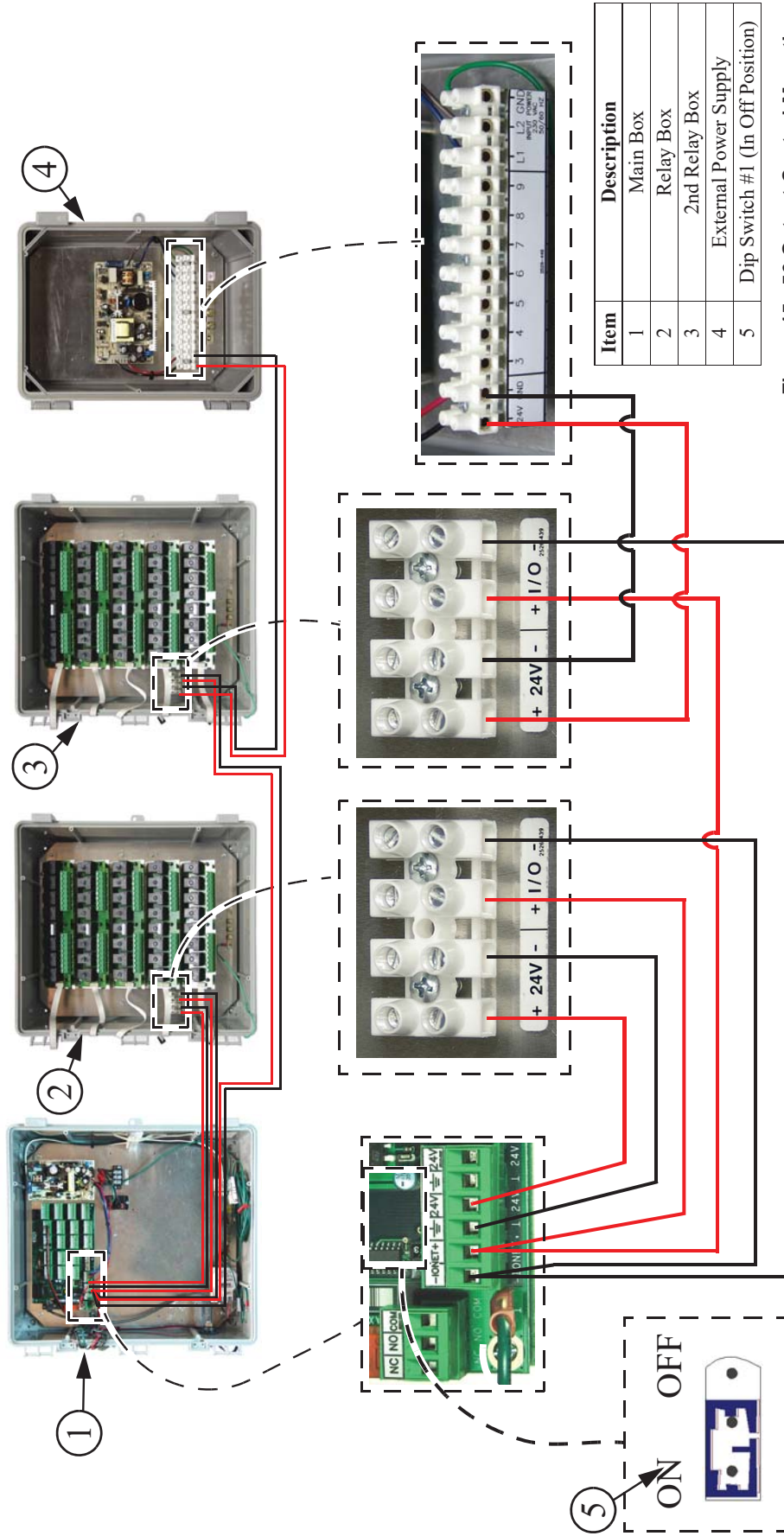

Figure 15. 56 Output Control Mounting

Caution: Do NOT run 24 Vdc and I/O Net wire close to and/or parallel with line (120 Vac or greater) wires. Doing so can cause operational failure in the Control and Void Warranty. If 24 Vdc or I/O Net wires need to cross line voltage wires make sure the wires cross at a 90 degree angle (See Figure 13). Also, no other electrical devices such as transformers, light dimmers, additional relays, etc. should be mounted inside the main box or near the 24 Vdc power or I/O Net wires.

Wiring the Control

Note: As with all electronic controls, we recommend the use of a backup system. This will provide continuous operation in the unlikely event of Control failure. Use the current Back Up Box Manual for wiring instructions.

The Chore-Tronics® 3 Controls consist of several different types of boards shown in **Figure 16**. The two Boards involved in wiring the Controls are the I/O Board and the Relay Module (RM Board).

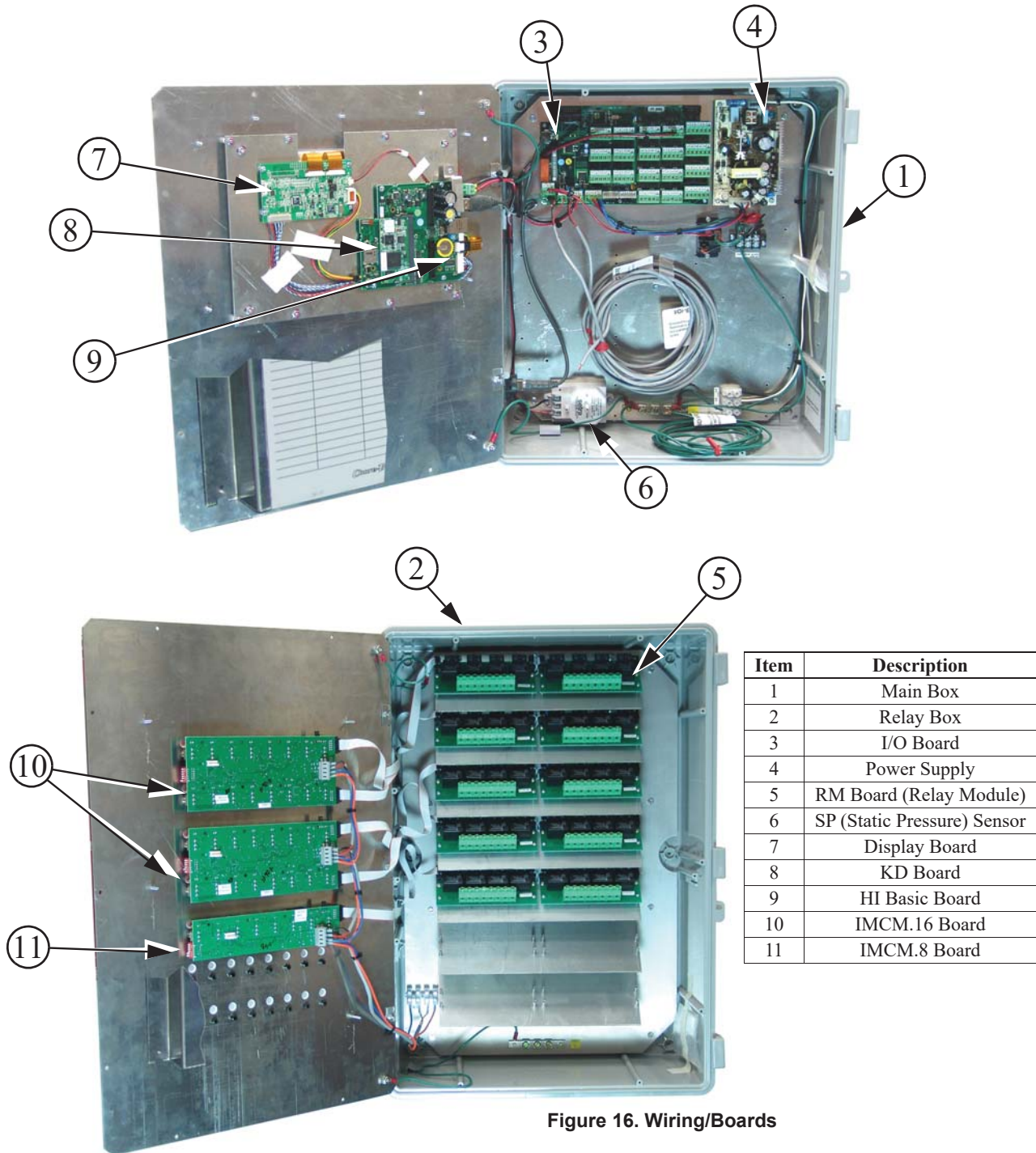

Figure 16. Wiring/Boards

When wiring the Control it is recommended that the line voltage wires be brought into the bottom of the Boxes and the low voltage wires (Temperature Sensors, Potentiometers, relative humidity, etc.) be brought in the side of the Control Box (See Figure 17).

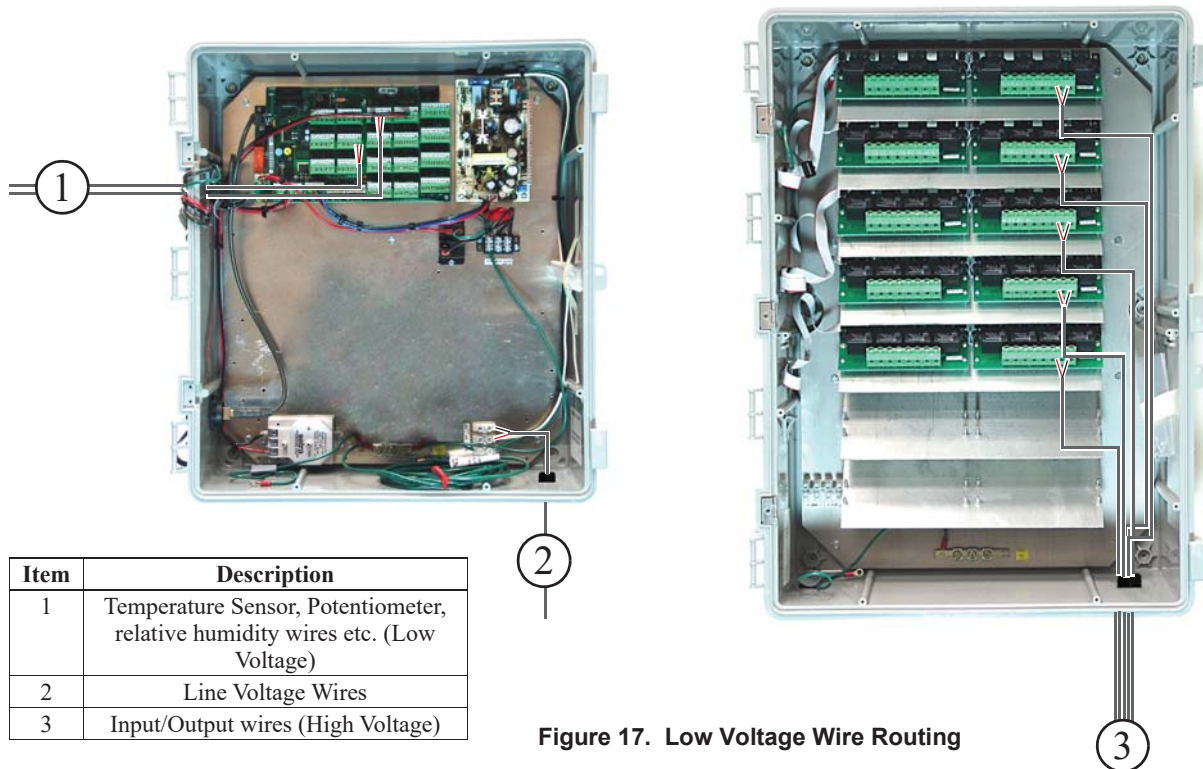

Figure 17. Low Voltage Wire Routing

When grounding the Control, connect only the Ground Rail of the Main Box to the Earth ground. Connect the Ground Rail from the Main Box to the Ground Rail of the Relay Box. It is recommended that a ground rod be located no more than 8' [2.438 m] to 10' [3.048 m] away from the Control. The Chore-Tronics® 3 Control should be connected to ground using a 12 gauge wire or larger. As always, check the local electric code for additional requirements.

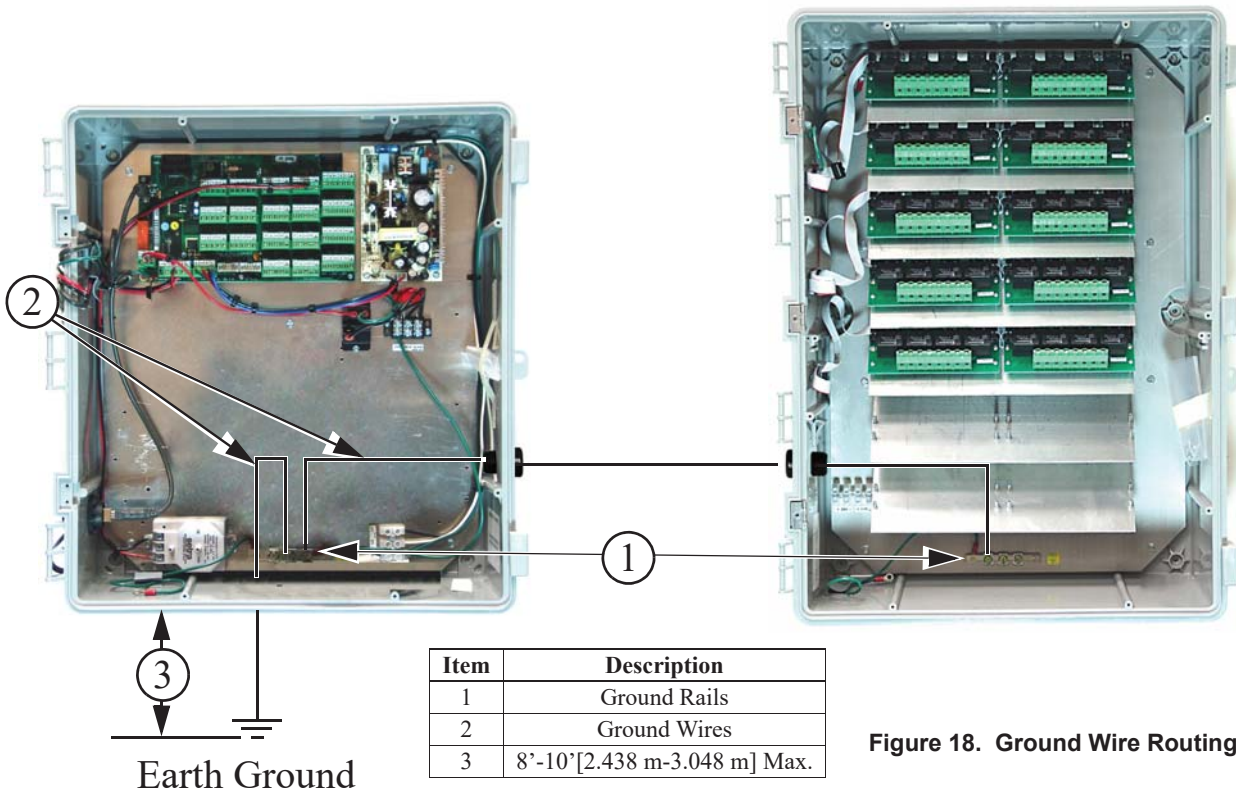

Figure 18. Ground Wire Routing

Analog Inputs

Analog Inputs consist of temperature sensors, the static pressure sensor, the relative humidity sensor and potentiometers (natural ventilation only). These inputs can be wired to any of the analog inputs (AI 1 thru AI 12) on the I/O board. The inputs that are pre-assigned are temperature sensors 1, 2 and 3, and the static pressure sensor. Use the diagram located on page 137 to record where each Input is wired to the Control.

Temperature Sensors

The Temperature Sensors require Non-Shielded 20 Gauge Twisted Pair Wire. This wire is available through Chore-Time. When routing this wire in the house be sure to keep it a minimum of 12"(305mm) away from line voltage wiring. If there is a need for the Sensor wire to cross line voltage wires cross them at a 90° angle to each other **as shown below**.

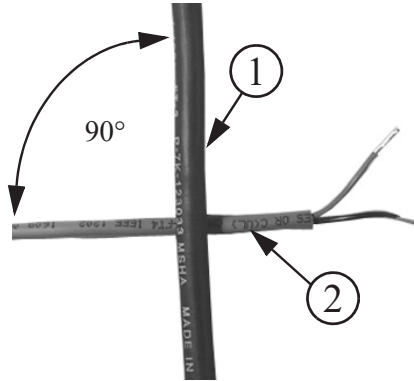

Item	Description
1	Non-Shielded Twisted Pair Wire
2	Line Voltage Wiring

Figure 19. 90° Cross-

The Temperature Sensor wires can be connected to any one of the Analog Inputs (AI1 through AI16) of the I/O board. Whatever AI Inputs the Temperature Sensors are connected to, make sure that the blue jumper above each Input is set to "R" as shown in **Figure 82 below**. There are no polarity restrictions for the Temperature Sensors.

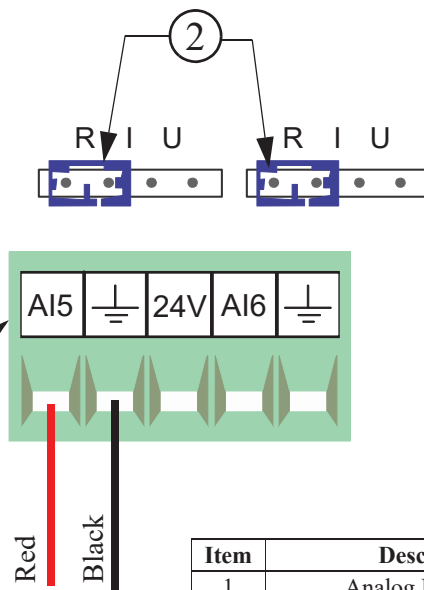
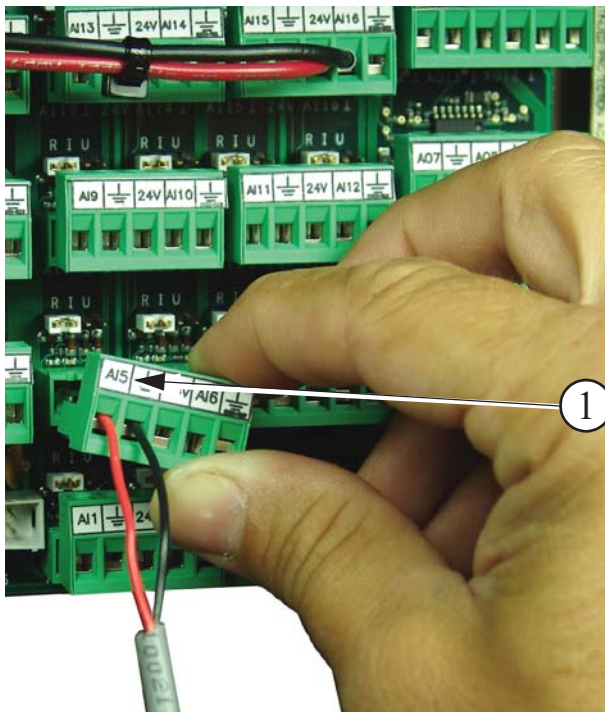

Item	Description
1	Analog Input (AI5)
2	blue jumper set to "R"

Figure 20. Temperature Sensor Wiring

Temperature Sensors Continued....

Route the wire through the back of the Temperature Sensor and connect it as shown in **Figure below**. Pull the wire through the back of the box until a drip loop is formed as shown.

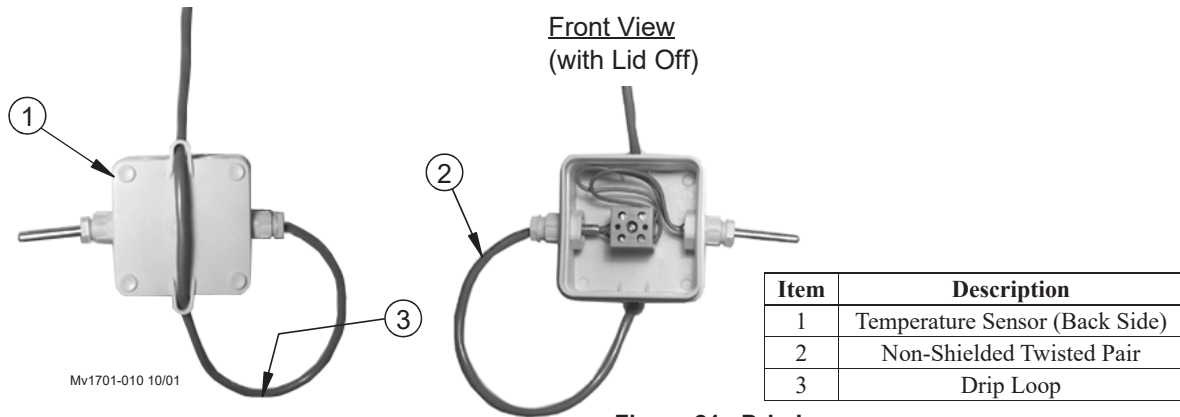

Figure 21. Drip Loop

Static Pressure (SP) Wiring

There is a Static Pressure Sensor included with every Chore-Tronics® 3 Control. This sensor is pre-wired from the factory to Analog Input #16 (AI 16) (**Figure 22**). If it is desired, the Static Pressure Sensor can be wired to any of the Analog Inputs (AI1 through AI16) (**See Figure 23 for example wired to AI1**). Please note that the Red wire must always be connected to the +24 volt terminal and the Black wire must be connected to the AI terminal being used. Make sure that whichever AI Input the SP sensor is connected to, that the Jumper above the Input is set to "I" position as shown. The Terminal Block is removed for clarity.

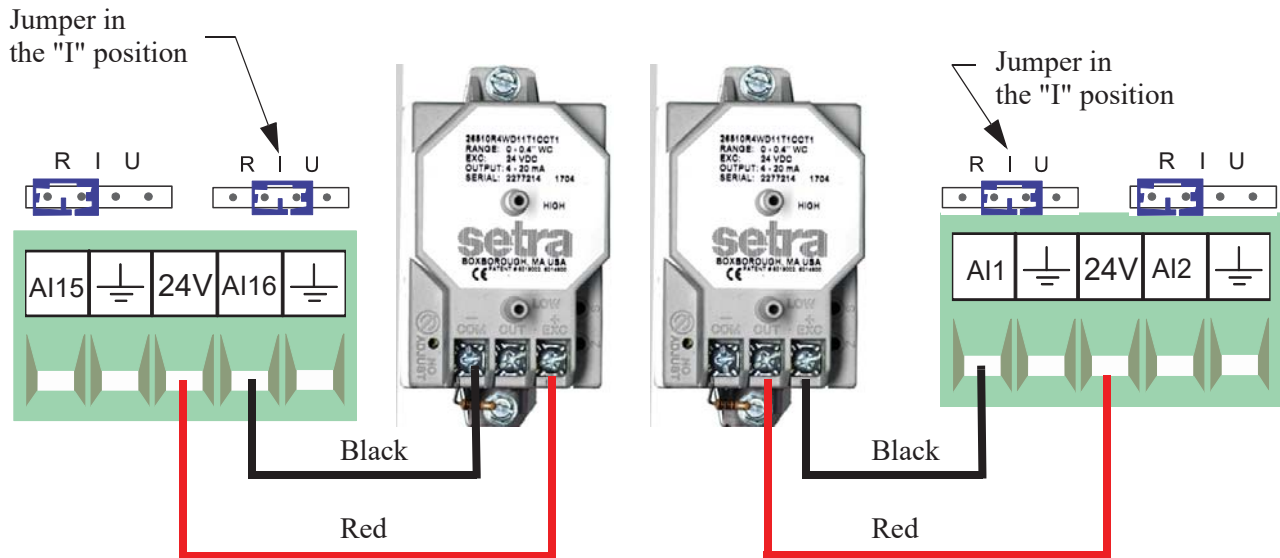
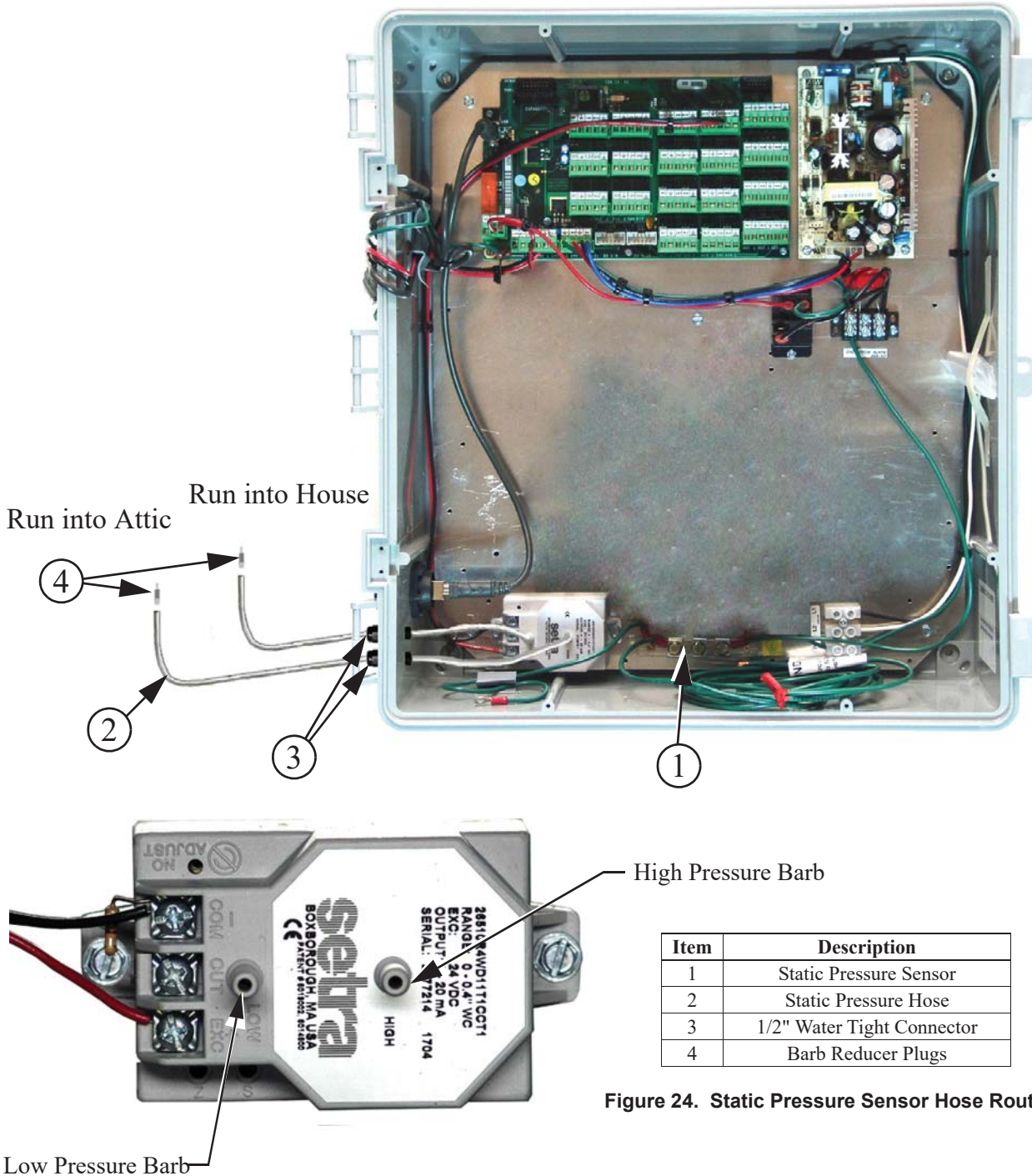

Figure 22. Static Pressure Sensor Pre-wired to AI16

Figure 23. Static Pressure Sensor Wired to AI1

To route the Static Pressure Hoses into the Chore-Tronics® 3 Main Box, first drill two 5/8" holes in the side of the Box, next to the sensor. Place a 1/2" water tight connector (Item 3, Figure 24) into each hole and tighten using the hardware provided. Route a 3/16" ID hose (Chore-Time part number 43071) through each of the Water Tight Connectors. Connect one hose to the low pressure barb on the SP module, and run that hose into the house. Connect another hose to the high pressure barb on the Sp Module. Run that hose into the attic or to outside air. Make sure the high pressure hose is in still air. Once the hoses have been routed and connected, place the Barb Reducer Plugs into the end of the hose opposite of the SP sensor.



Item	Description
1	Static Pressure Sensor
2	Static Pressure Hose
3	1/2" Water Tight Connector
4	Barb Reducer Plugs

Figure 24. Static Pressure Sensor Hose Routing

Relative Humidity Sensor(RH) Wiring

The optional Relative Humidity Sensor (**Item 1, Figure 25**) requires a three-conductor wire to connect the sensor to the Chore-Tronics® 3 I/O board. The Sensor is connected to one of the Analog (AI) Inputs on the IO board.

Note: Terminal #1 on the relative humidity sensor is connected to the +24 v terminal on the IO board (see diagram). This is the same +24 v terminal used by the Static Pressure Sensor. Terminal #2 on the Relative Humidity Sensor is connected to the Analog Input (AI) terminal of the analog Input being used (**See Figure 25**). Terminal #3 is connected to the ground terminal of the Analog Input (AI) being used. Make sure that the Blue Jumper above the Analog Input that the RH sensor is connected to is set to "U".

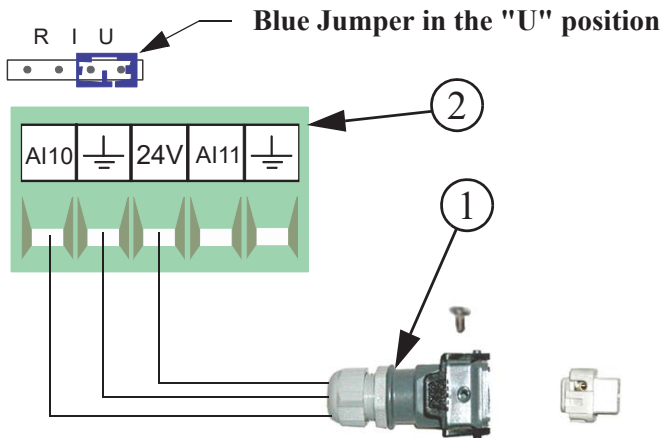

Item	Description
1	Relative Humidity Sensor Quick Connect
2	I/O Board Analog Input (AI) Terminal of your Choice

Figure 25. Relative Humidity Sensor Wiring

Potentiometer Wiring (Natural Ventilation only)

If natural ventilation is being used, the Potentiometer(s) that are attached to either the main curtain machine(s) (Internal Potentiometer), or the main curtain cables (External Potentiometer) need to be wired to the Chore-Tronics® 3 I/O Board. The Potentiometers need to be connected using the same Twisted Pair Wire that is used for the Temperature Sensors and follows the same wiring rules. Each Potentiometer needs to be wired to one of the Analog Input (AI) Terminals on the IO board. Make sure that whichever AI Input the Potentiometer is connected to that the Blue Jumper above the Input is set to "R" (**See Figure 26**). To connect the sensor wire to the Potentiometer itself, please see Chore-Time instruction manual MV1251 for internal Potentiometer wiring, or MV1566 for external Potentiometer wiring.

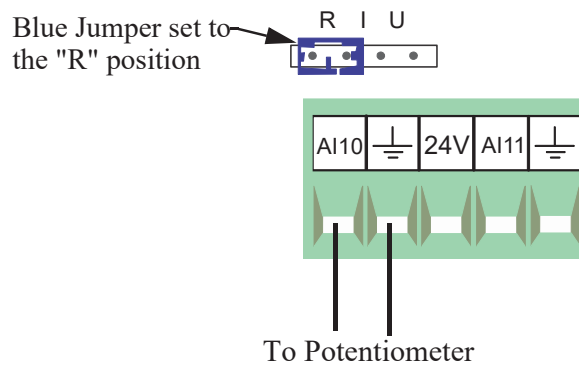

Figure 26. Potentiometer Wiring

Digital Inputs Wiring

Digital inputs consist of Water Meters, Feed Scales, Air Speed Sensor, Low Water Pressure Switch, Max Feed Run Time Alarm Input, and PDS Flush Feedback. These Inputs can be wired to any of the digital inputs (DI 1 thru DI 8) on the IO board (Figure 27 below). Complete the analog input Assignment diagram on page 137 to indicate where each digital input is connected to the IO board and also record it on the Input Assignment Decal (Item 1, Figure 27) that is placed on the Cover Plate inside the Chore-Tronics® 3 Main Box. Also refer to the following sections for information specific to each type of digital input.

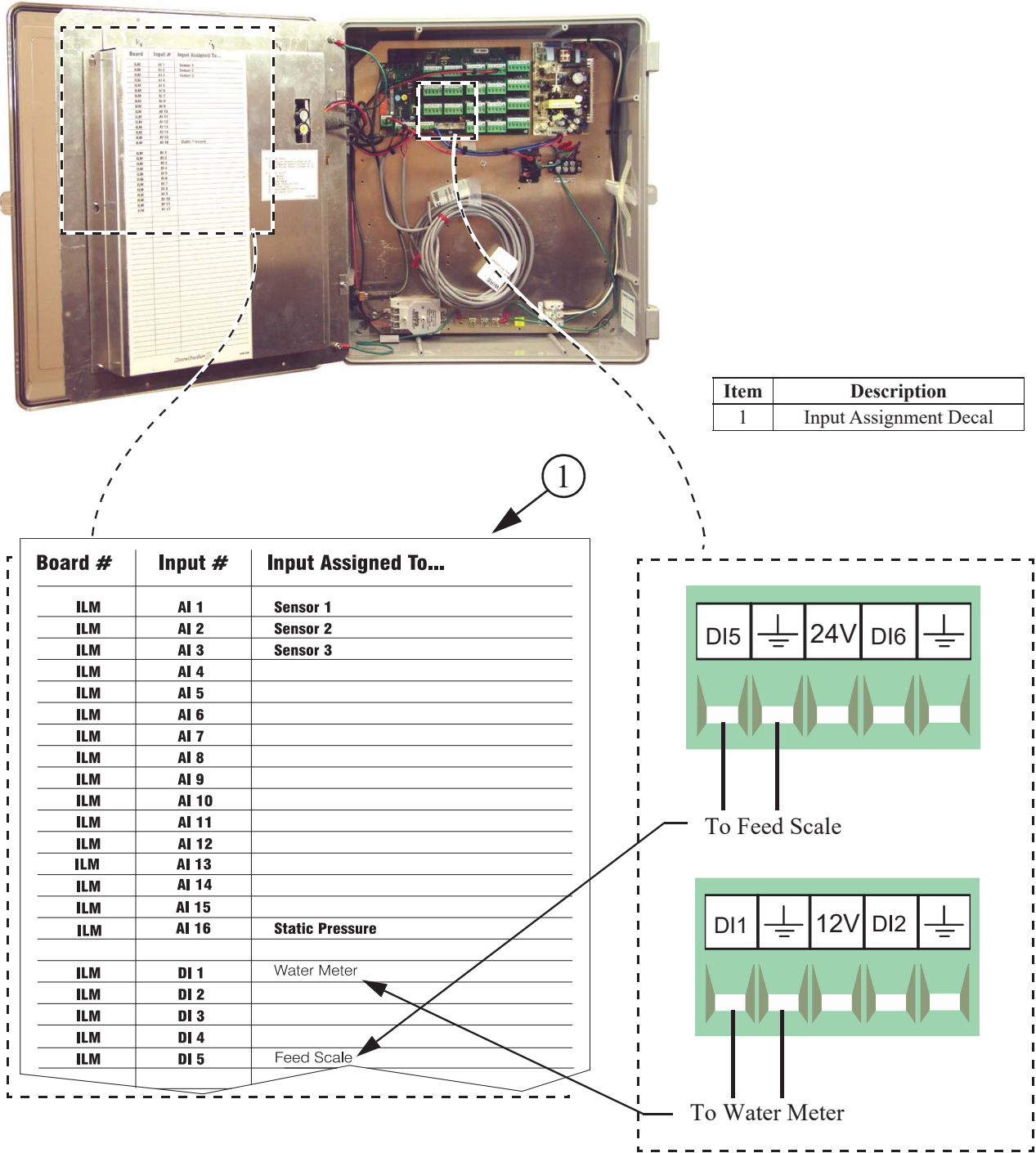

Figure 27. Digital Input Wiring

Water Meter Wiring

If there are Water Meters connected to the Control, they need to be connected to one of the Digital (DI) Inputs of the IO board. Use Twisted Pair Wire to connect the terminals on the Water Meter with the Chore-Tronics® 3 Control. If a Water Meter not sold by Chore-Time is used, make sure that it has a dry contact output. **Do not** use a Water Meter that sends voltage out with every pulse.

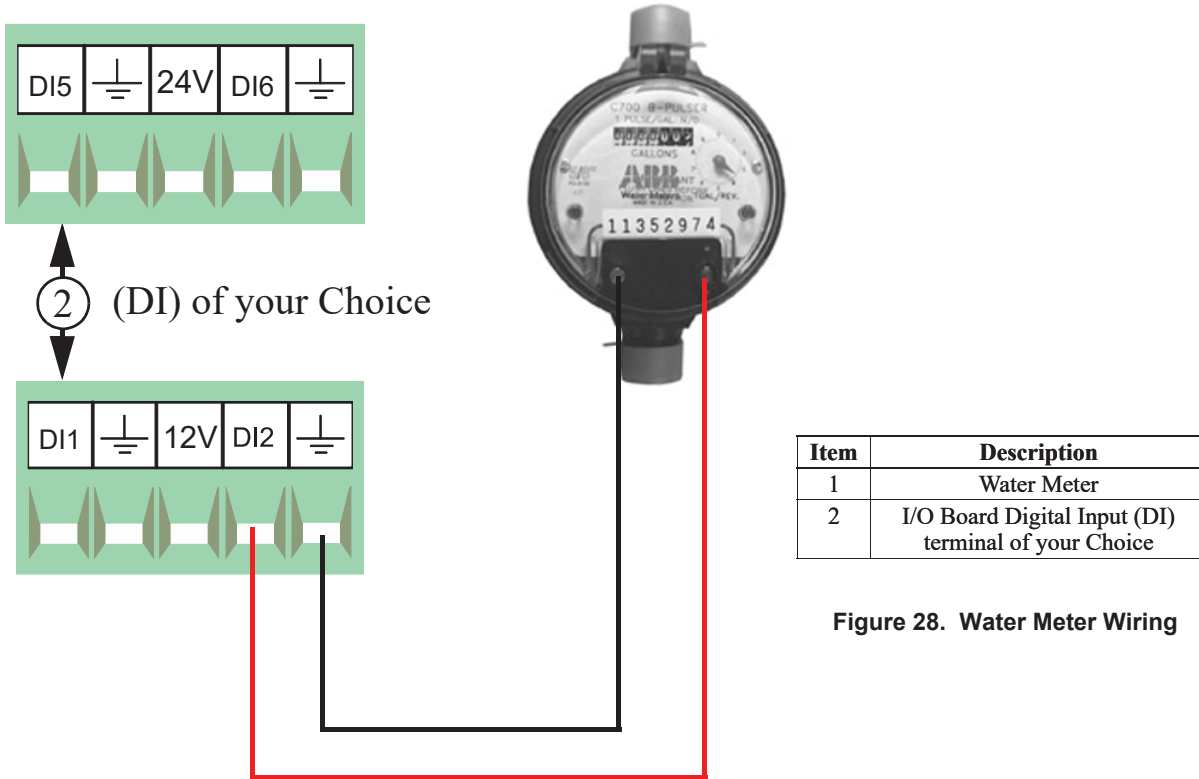

Figure 28. Water Meter Wiring

Low Water Pressure Switch Wiring

If the Low Water Pressure Switch (Chore-Time part no. 46597) is used, it needs to be connected to one of the Digital (DI) Inputs of the IO board. Use Twisted Pair Wire to connect the Low Water Pressure Switch to the Control. If a non-Chore-Time pressure switch is used, make sure it is a low pressure, reverse action switch.

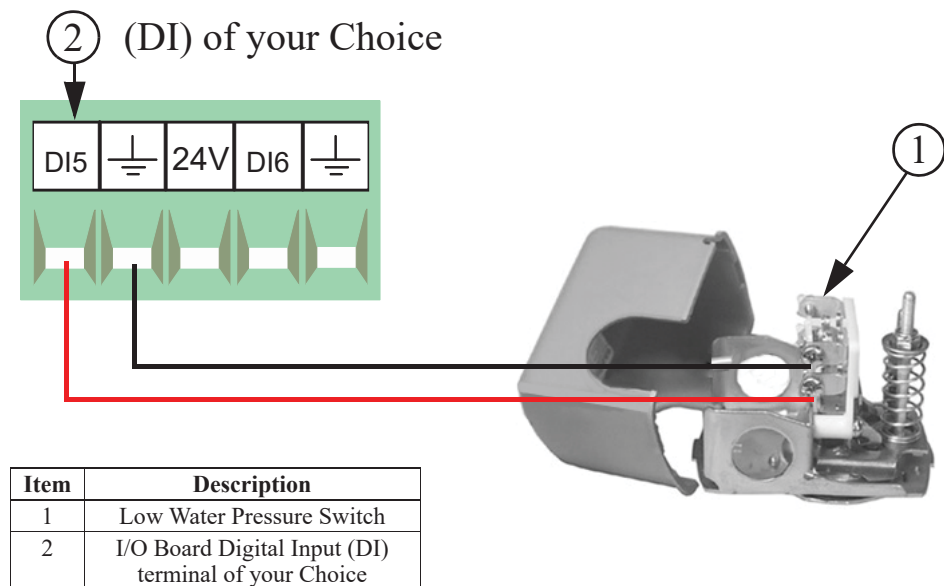

Figure 29. Low Water Pressure Switch Wiring

Maximum Feed Runtime Alarm Input

If the Maximum Feed Runtime Alarm is used, the Input for the alarm must be connected to one of the Digital (DI) Inputs of the IO board. A dry contact relay must be connected to the IO board. The coil of the relay should energize whenever the fill system's hopper level switch closes (See Figure 30).

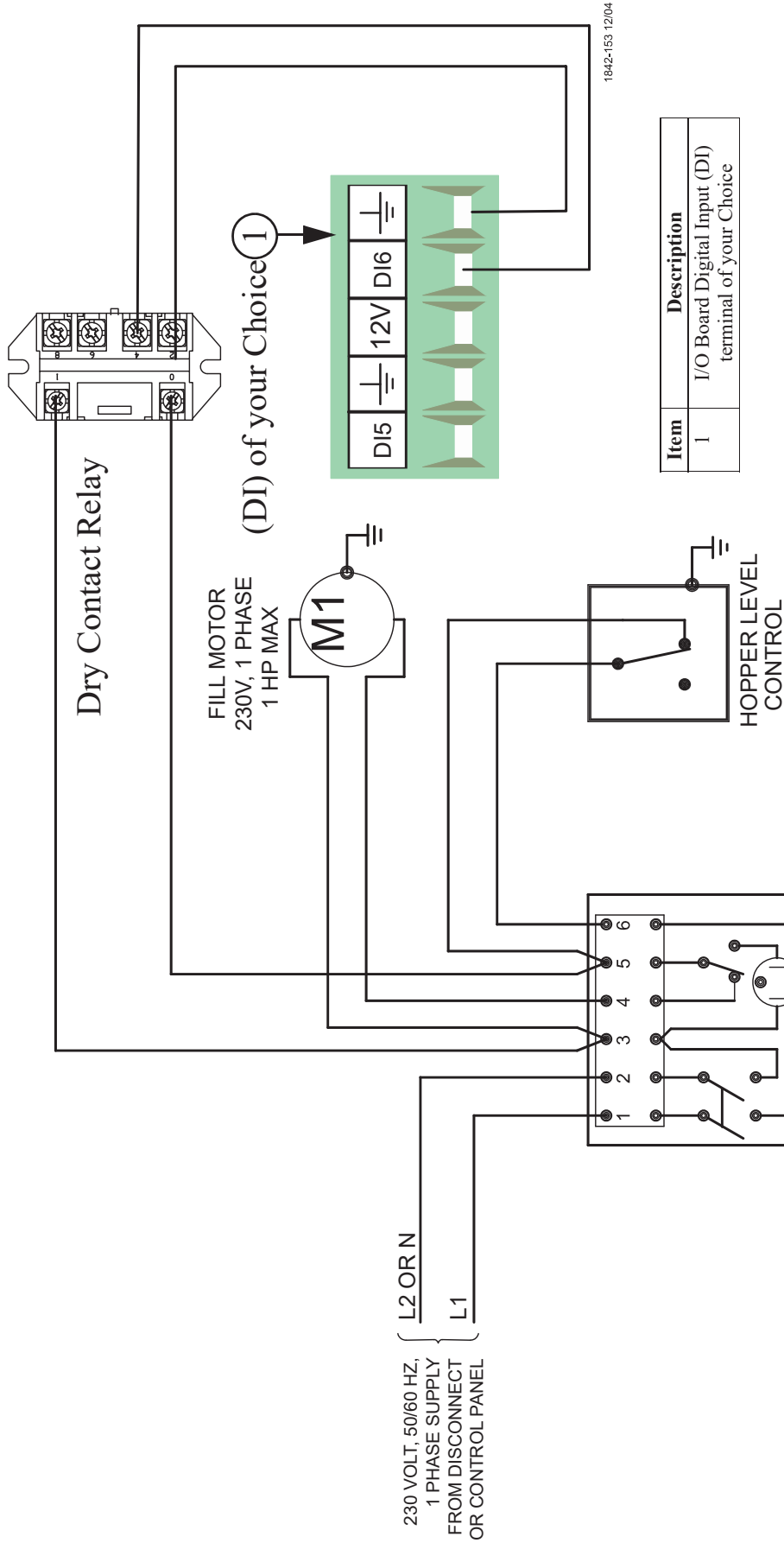
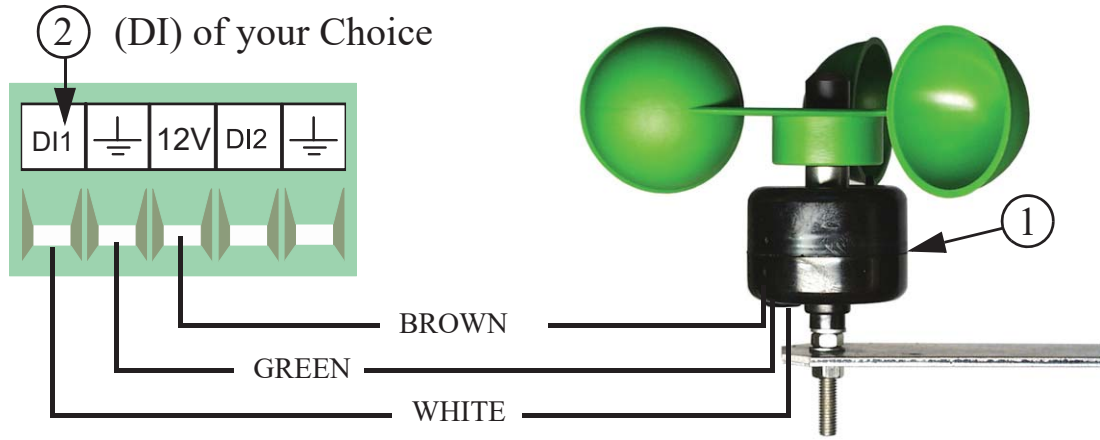

Figure 30. Max Feed Runtime Alarm Input Wiring

Airspeed Sensor Wiring

The Airspeed Sensor requires a three conductor wire to connect the Sensor to one of the Digital (DI) Inputs on the IO board. It is recommended that the digital input chosen is adjacent to one of the 12 volt outputs on the IO board (**Figure 31**). The Brown wire on the Sensor needs to be connected to the +12 volt output, the Green wire on the Sensor needs to be connected to the ground terminal of the digital input being used, and the White wire needs to be connected to the DI(x) terminal of the digital input being used.



Item	Description
1	Airspeed Sensor
2	I/O Board Digital Input (DI) terminal of your Choice

Figure 31. Airspeed Sensor Wiring

Feed Scale Wiring

If one or more Feed Scales are used, they need to be connected to one of the Digital (DI) Inputs on the IO board using Twisted Pair Wire. Connect the switch located on the side of the Feed Scale to the IO Board using the blue and brown wires (**Figure 32**). See manual MT1811 for more information.

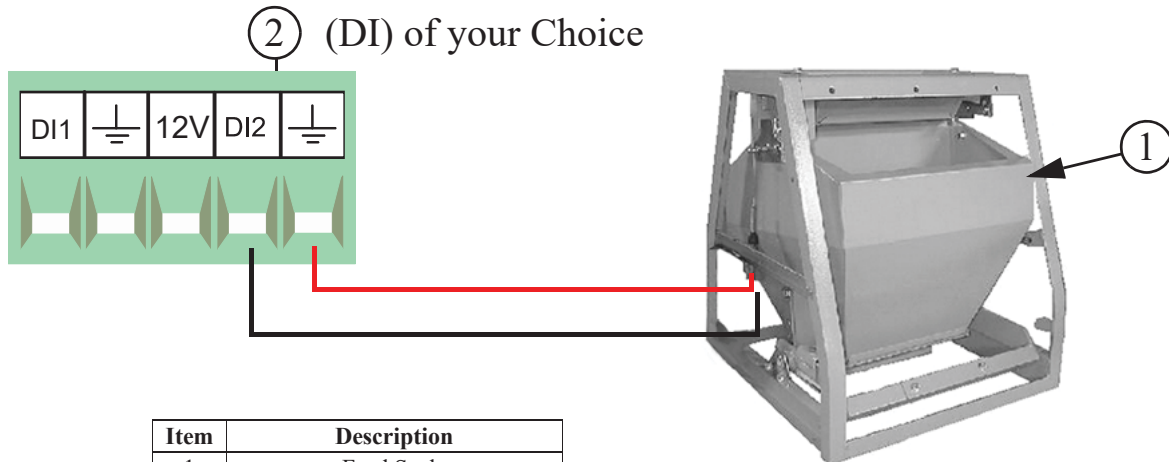

Item	Description
1	Feed Scale
2	I/O Board Digital Input (DI) terminal of your Choice

Figure 32. Feed Scale Wiring

PDS Flush Feedback Wiring

If a PDS Drinker Control is being used to automatically flush water lines, then the Control can ignore pulses coming from the Water Meter(s) while flushing is taking place. If this option is used then a dry contact relay must be connected to one of the Digital (DI) Inputs of the IO Board. The coil of the relay should be energized whenever the Control begins its flushing sequence. See **Figure 33 below** for connecting the relay to the IO board of the Control.

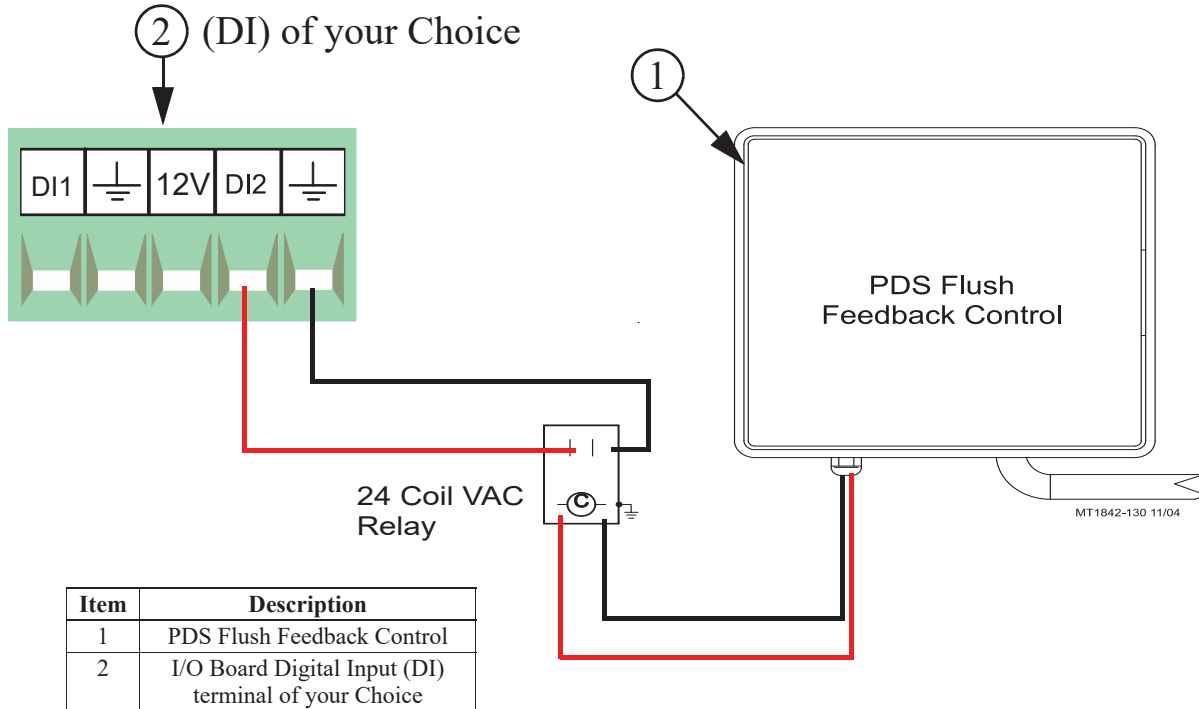

Figure 33. PDS Flush Feedback Wiring

Remote Light Dimmer Control Wiring

Before connecting the I/O board to a Light Dimmer, be sure to check that the light dimmer is equipped for remote control dimming. The Light Dimmer must be able to accept a 0-10 or 10-0 Vdc signal from the I/O board. Refer to the information provided by the Light Dimmer manufacturer for remote dimming wiring instructions.

The Light Dimmer connects to the I/O board at the Analog Output #1 (AO1) (See **Figure 34 below**). Be sure that the positive terminal on the I/O board matches with the positive wire/terminal on the Light Dimmer.

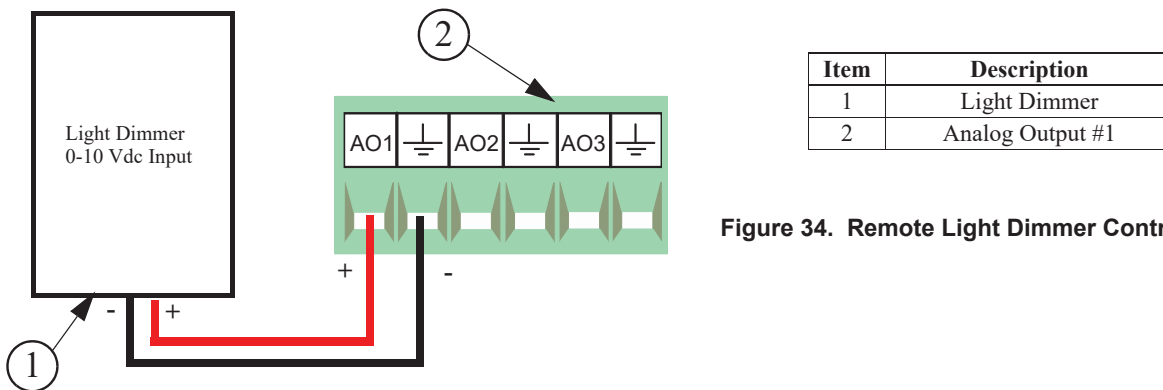
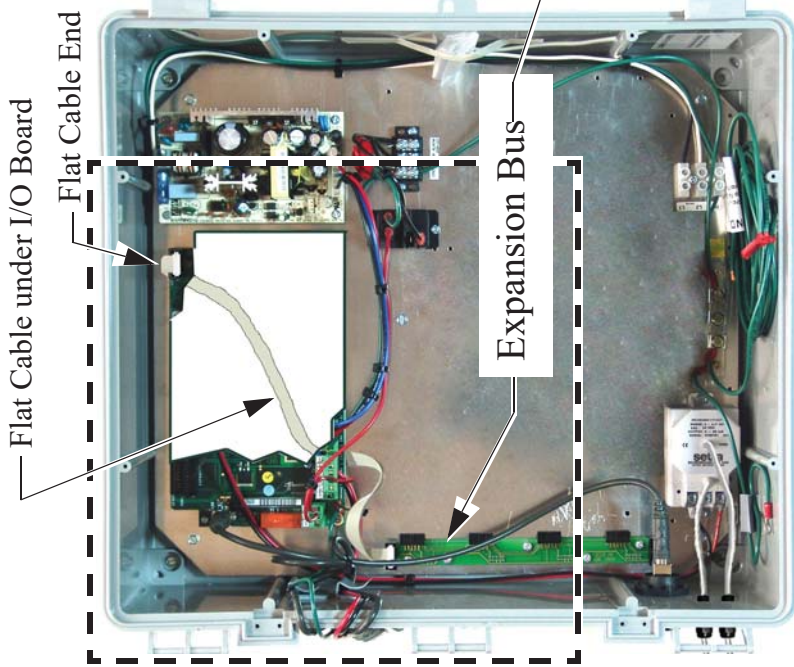
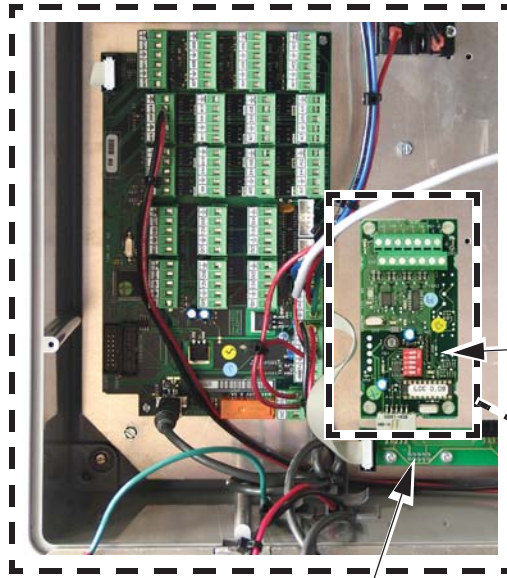

Figure 34. Remote Light Dimmer Control Wiring

Bird Scale Wiring using the LCC Board (Scales Less than 150' from Control)



Insert a Small Screw Driver and press while inserting wires to lock in place



LCC Board (48735)

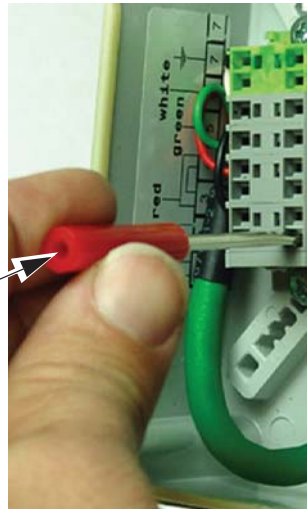

Bird Scale Load Cell

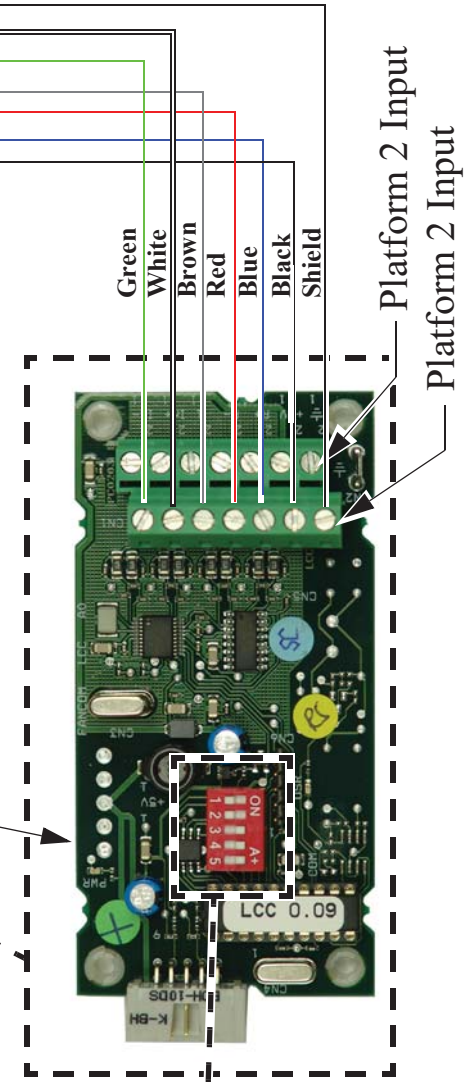

Address Settings		Dip Switch				
Address #	1	2	3	4	5	
0	-	-	-	-	-	-
1	X	-	-	-	-	-
2	-	X	-	-	-	-
3	X	X	-	-	-	-
4	-	-	X	-	-	-
5	X	-	X	-	-	-
6	-	X	X	-	-	-
7	X	X	X	-	-	-
8	-	-	-	-	X	-

"X" is Dip switch in the On position

Bird Scale Wiring using the LCC Board (Scales More than 150' from Control)

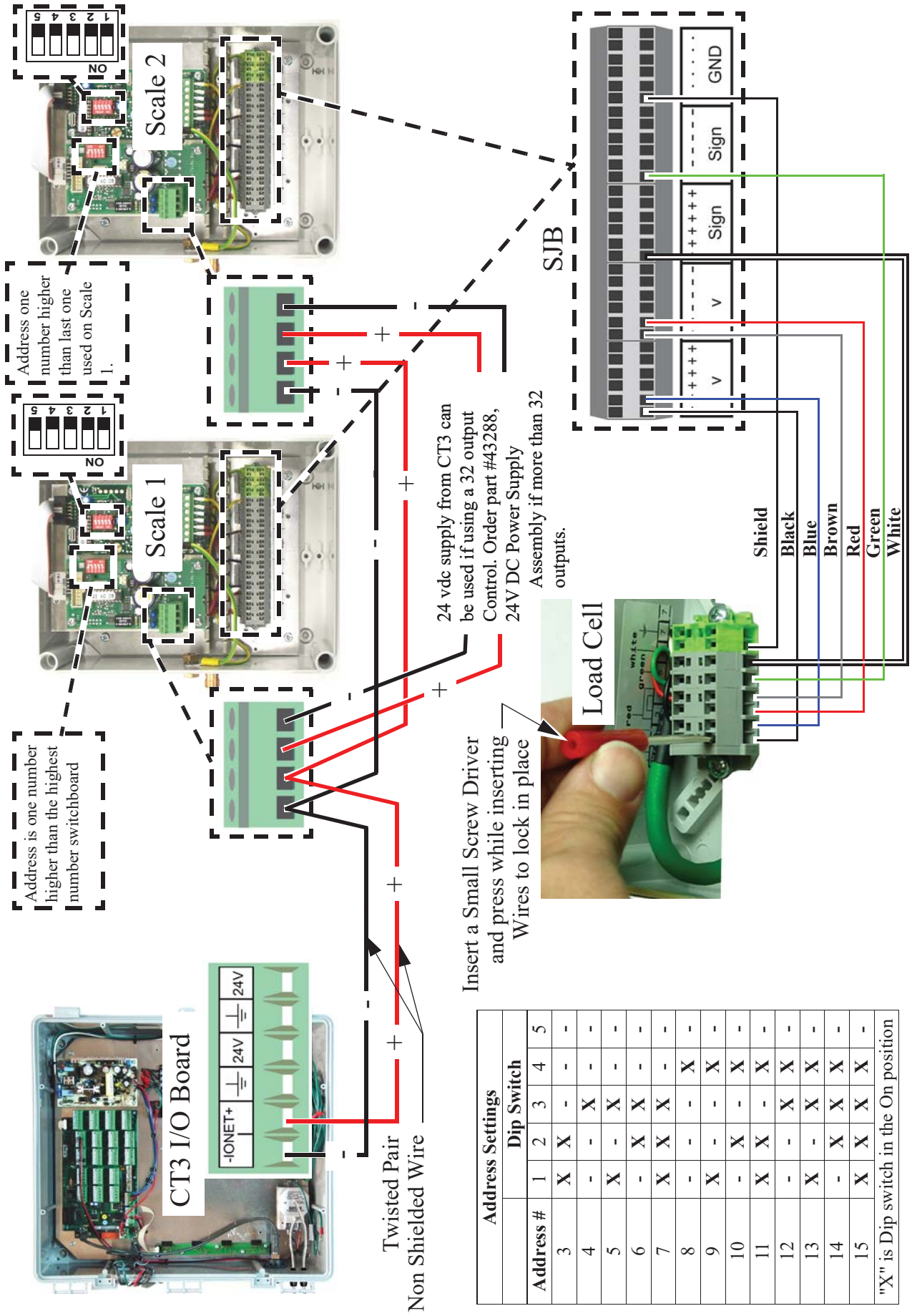

Expansion Board Installation/Wiring

If it is desired to have more than 12 analog inputs and/or 8 digital inputs, then an Expansion Board(s) is needed to connect the inputs. There can be a maximum of 7 Expansion Boards added to the Chore-Tronics® 3 Main Box. These seven boards can consist of Analog Expansion Board, Digital Expansion Boards, or both.

To add an Expansion Board, an Expansion Bus (I2C board) kit part no. 49667 must first be installed. Attach the Expansion Bus to the Back Plate using the hardware provided using existing holes as **shown in Figure 35 below**. Slide an Expansion Board into one of the Expansion Bus connectors. Attach the Expansion Board to the Back Plate using the hardware provided. Connect the Expansion Bus to the I/O Board with the Flat Cable provided as **shown**. **Note:** Remove the I/O Board and run the Flat Cable underneath it to keep it out of the way **as shown**.

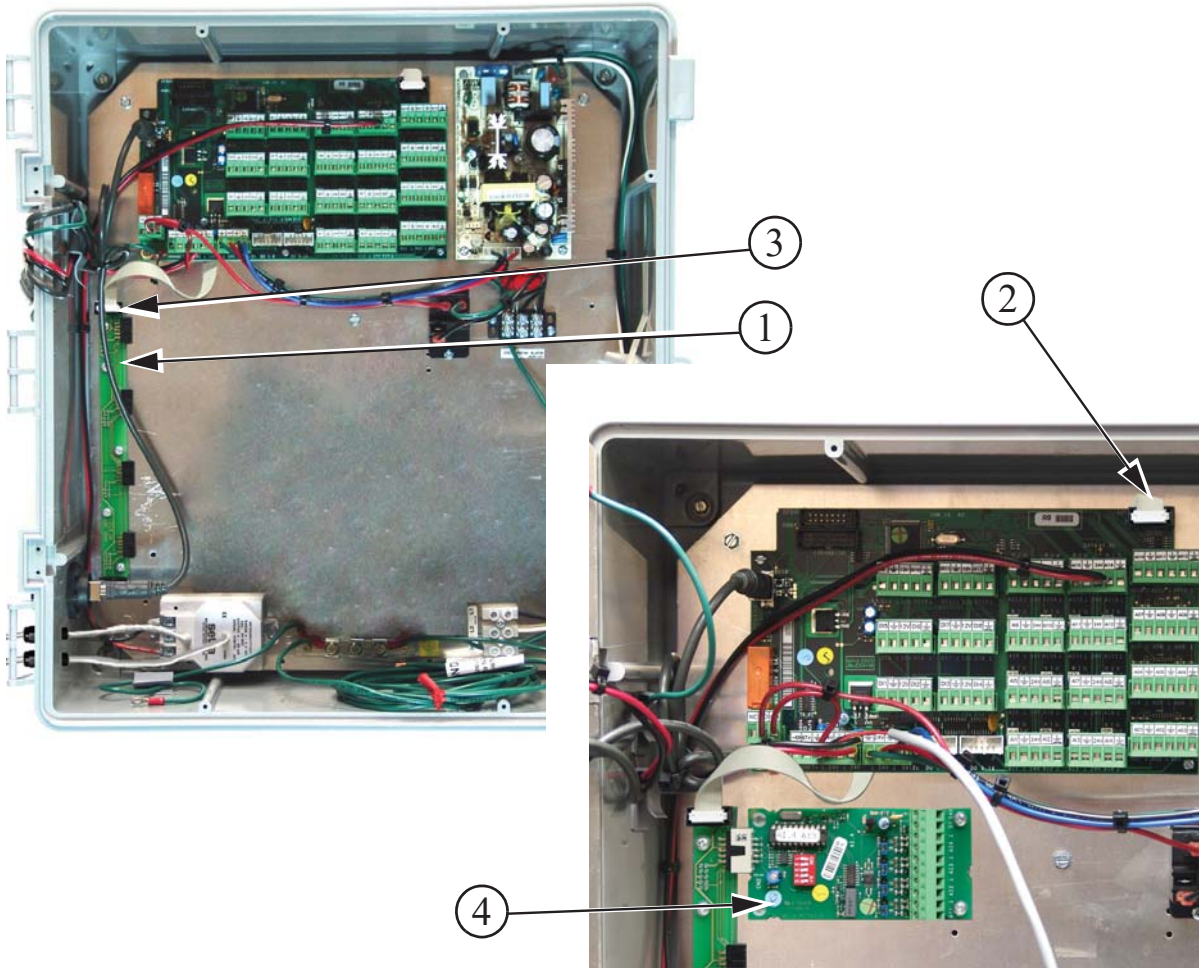

Item	Description
1	Expansion Bus
2	Flat Cable End (I/O Board End)
3	Flat Cable End (Expansion Bus end)
4	Expansion Board

Figure 35. Expansion Boards

Expansion Board Dip Switch Setting- Each Expansion Board installed must have the DIP switches set properly. These DIP switches are used to assign a number to each Expansion Board so the Control can identify each Board. To assign the first Expansion Board installed to #1, set the DIP switches for Expansion Board 1 so that the number one switch is in the "OFF" position and the rest of the switches are in the "ON" position. See Figure 36 below for Dip Switch settings for all seven Expansion Boards. **Note:** Only the first two Expansion Boards are shown.

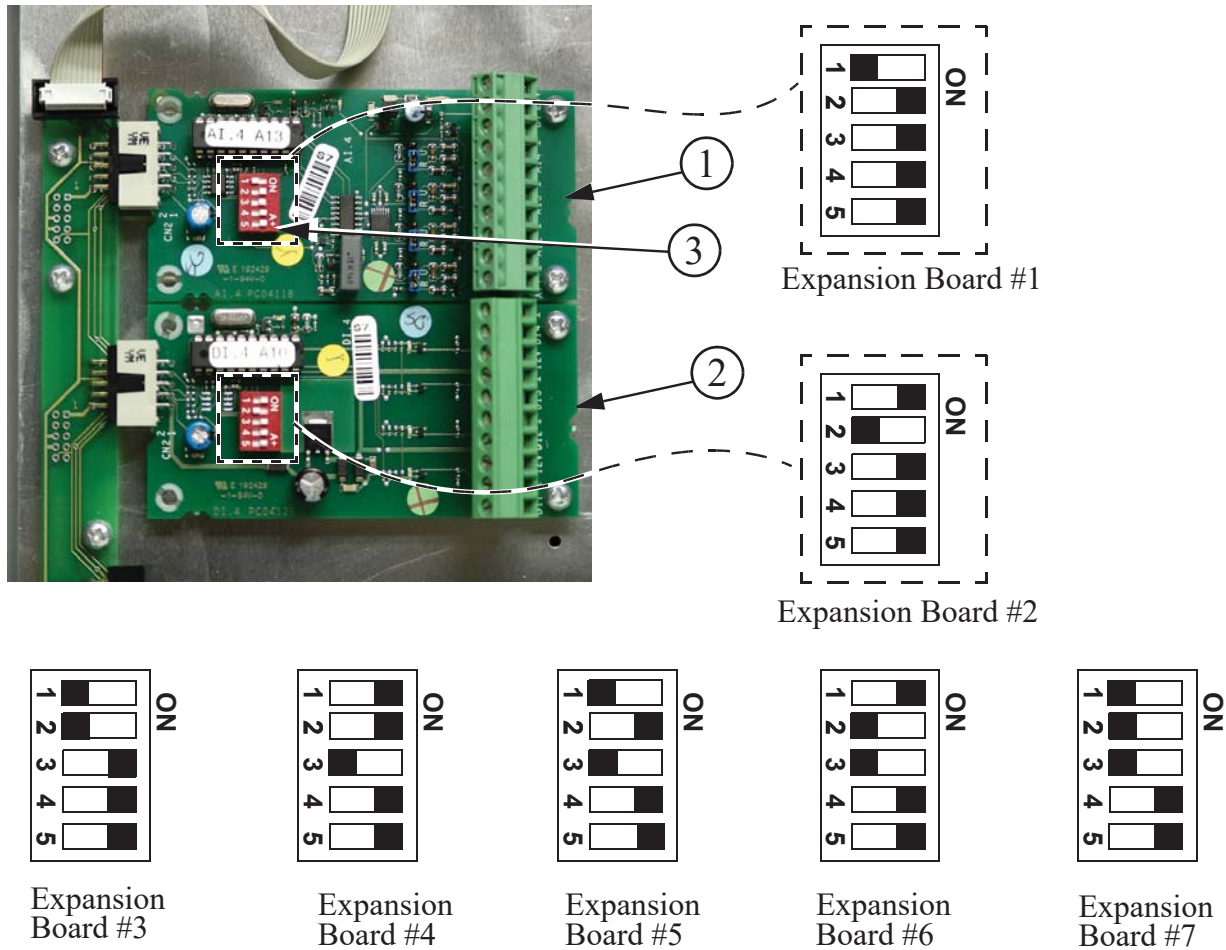

Item	Description
1	Expansion Board #1
2	Expansion Board #2
3	Expansion Board Dip Switch

Figure 36. Expansion Board Dip Switch Settings

Analog Expansion Boards- Each Analog Expansion Board (AI.4 board) adds 4 additional Analog Inputs to the Chore-Tronics® 3 Control. There is a Blue Jumper located above each Analog Input (**Item 2, Figure 37**). This Blue Jumper needs to be set in the "R" position if a resistive Analog Input (Temperature Sensors and Potentiometers) is connected. The Blue Jumper should be set to "U" if a voltage Analog Input (Static Pressure Sensor, Relative Humidity Sensor) is connected. There is a +24 Vdc output available if needed. When assigning the Input in the Setup-General screen make sure that the number of the Analog Expansion Board is correct along with the number of the Analog Input itself (1-4). It is highly recommended that the name of the Input as well as its assigned location be written on the Input Decal located on the Cover Plate of the Main Box and also recorded in the **Input Assignments Diagram on page 137**.

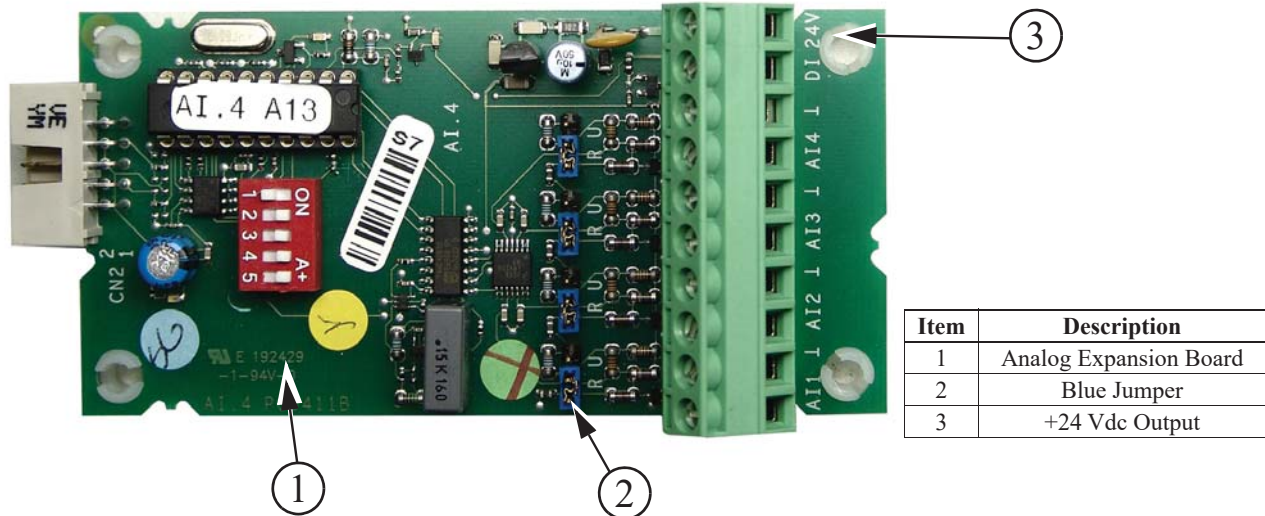

Figure 37. Analog Expansion Board

Digital Expansion Boards- Each Digital Expansion Board (DI.4 board) adds 4 additional digital inputs to the Chore-Tronics® 3 Control. There are multiple +12 Vdc outputs available if needed (**Item 2, Figure 38**). When assigning the Input in the Setup-General screen make sure that the number of the Digital Expansion Board is correct along with the number of the digital input itself. It is highly recommended that the name of the Input as well as its assigned location be written on the Input decal located on the cover plate of the main box and also recorded in the **Input Assignment Diagram on page 137**.

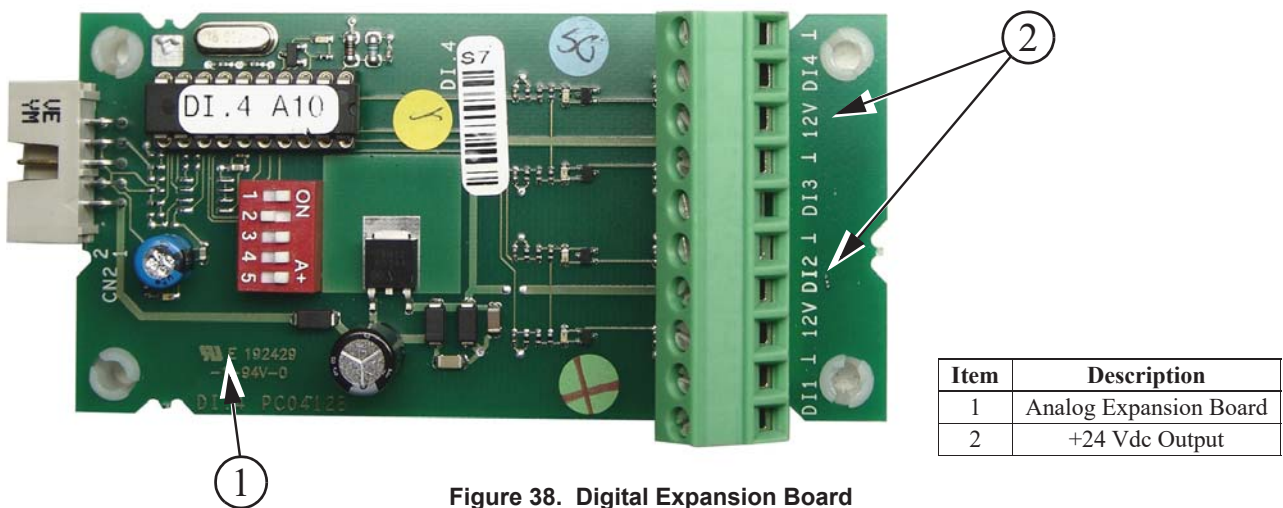

Figure 38. Digital Expansion Board

Once the screen has been adjusted, all assigned outputs should be tested individually by placing the Manual Switches located on the Relay Box to the "MANUAL ON" position (See **Figure 39**). This will also serve as a way of verifying that the proper output was wired to the proper Relay and/or the proper Output Sticker was placed over the Toggle Switch.

Caution: Before turning any Switch to the on position, make sure all people and objects are clear of the device being turned on to avoid injury or damage.

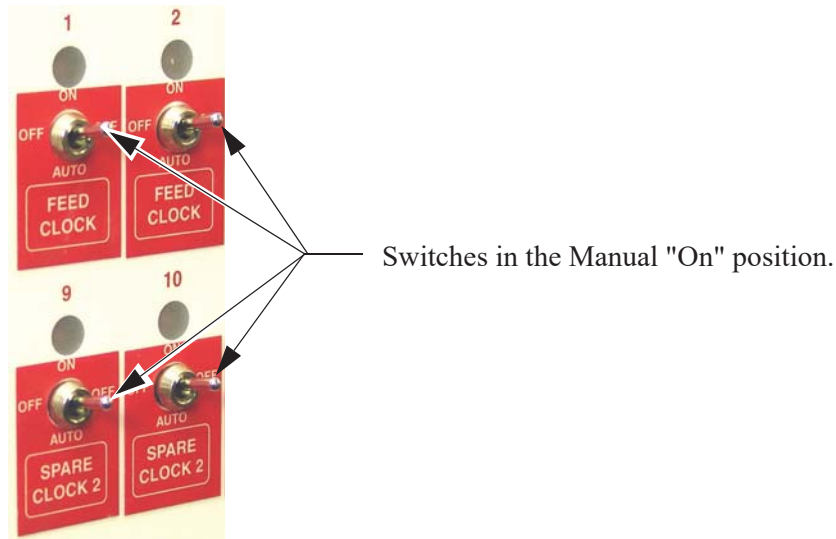

Figure 39. Manual "On"

When testing the Toggle Switches for the Curtain and Inlet Machines, be sure to test them one Switch at a time.

After testing the open switch, place it in the manual "off" position before placing the close switch in the manual "on" position. If you try to put both switches in the manual "on" at the same time you will send a double signal to the Curtain Machine Motor.

Testing the Back Up Box

To test the Back Up Box, first turn the power off to the Chore-Tronics® 3 Control only. This should cause the Tunnel Curtain to open and the first set of Back Up Fans should activate. If this test is successful, turn the power back on to the Chore-Tronics® 3 Control. Then adjust thermostat number one until it activates. Then adjust the second thermostat until it activates. This should cause the second set of Back Up Fans to activate. After all Back Up Fans are operating, deactivate the first two thermostats. Then adjust the third thermostat until it activates. This should cause the Back Up Heaters to activate.

After all of the outputs and back ups have been successfully tested, make sure all manual toggle switches are in the manual "off" position and proceed to the "**Setup**" portion of this manual beginning on **Page 18**.

Wiring of Outputs

The outputs for the Chore-Tronics Controls (Fans, Curtain Machines, Brooders, etc.) are wired to one of the Relays on the Relay Module or (RM Board(s)). The RM Board consists of eight 1hp motor load Relays. Each Relay has single-pole, single-throw normally open contacts. It is strongly recommended that the assignment of outputs to the Relays be done before starting to wire the Control. This will make routing of the electrical wires through the Relay box much easier (See Figure 40).

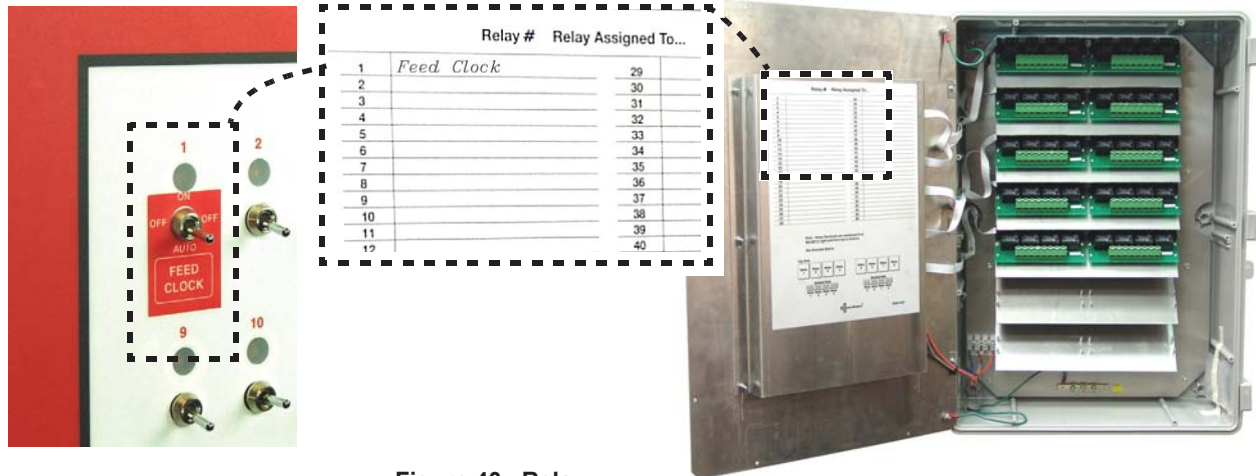

Figure 40. Relay

The appropriate output stickers should be placed over the toggle switches used, if it has not already been done prior to mounting. Please see the wiring diagrams on the following pages for wiring Chore-Time ventilation equipment. (Wiring diagrams for Fans, Linear Lifts, Super Lifts, Brooders, Turbo Cool, Mister Cool). For other types of equipment please refer to wiring diagrams supplied with the equipment.

MS Board Dip Switch Positions

The MS Board Dip Switches are located on the ends of the Manual Switch Boards as shown in **Figure 107 below**. New Controls come from the factory preset. This information is provided only when a replacement board is used. See **Figures 41 and 42 below** for Dip Switch settings for the First and a Second Relay Box if used.

Note: If the bottom most Board is replaced, make sure the Jumper in the upper right hand corner of the board is in the "On" position.

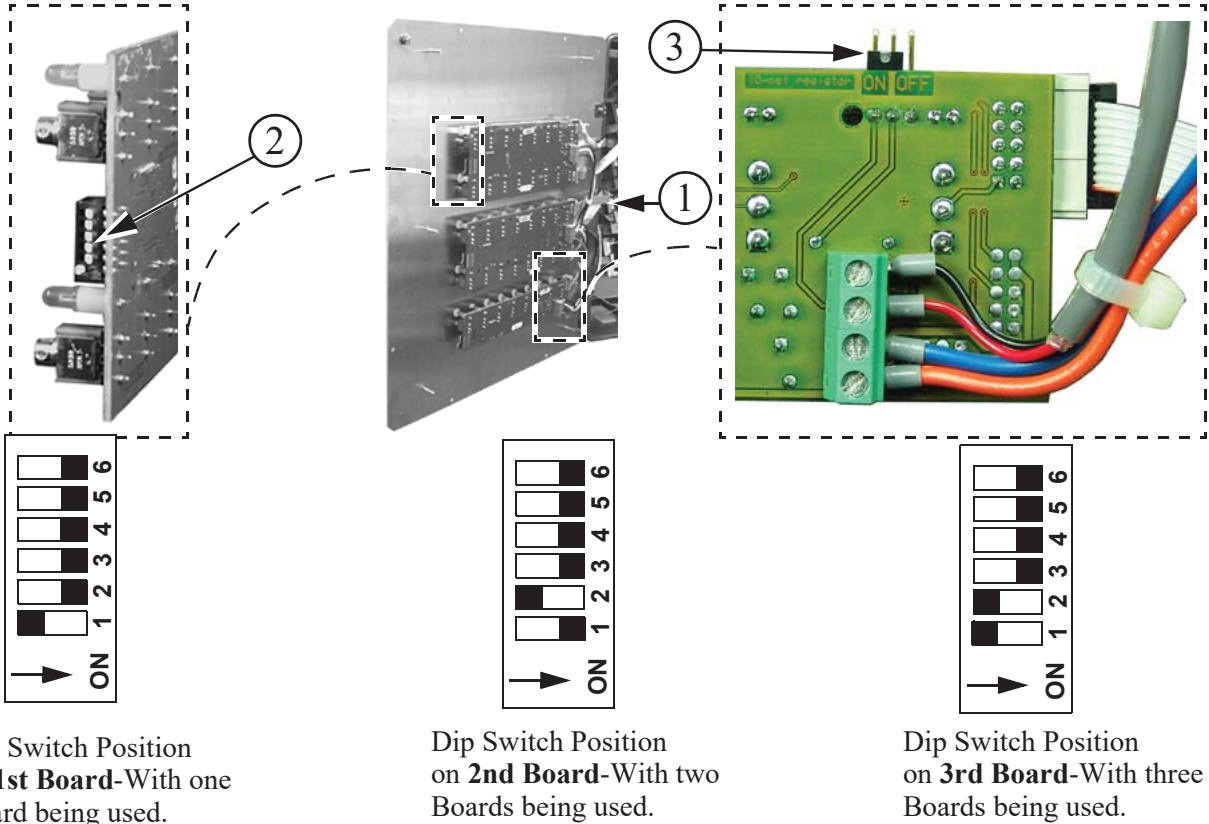

Item	Description
1	Relay Box
2	Dip Switch
3	Jumper "ON" position

Figure 41. Dip Switch Settings 1st Relay Box

Dip Switch Settings for the Second Relay Box

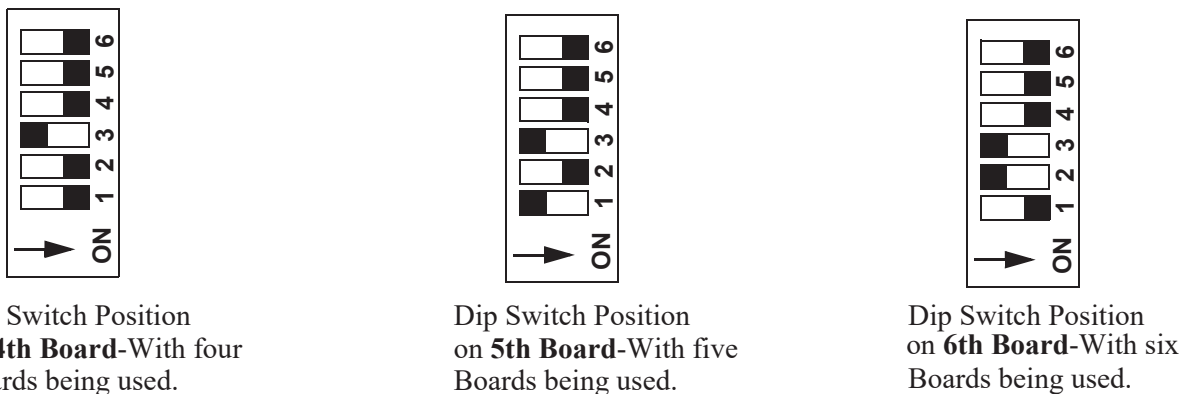

Figure 42. Dip Switch Settings 2nd Relay Box

PC Connection

Chore-Tronic's 3 controls communicate via Ethernet. The controls are networked together using Cat. 5e Ethernet cable. The max distance of a cable run is 315 ft. A Ethernet switch or router must be used to continue the network if more than 315ft.

A specific IP address must be assigned to each controller that is in the same IP range as the Computer and or Router. Refer to "General Setup" on page 18 item 10 in this manual on where to edit the IP address.

PC on the farm without internet

A static IP address must be enter in the LAN network settings in the PC. In this example the static IP address of 192.168.2.21 was used. The IP address of each controller has to been set in the same range (192.168.2.?) the last number of the IP must be different and the first 3 the same.

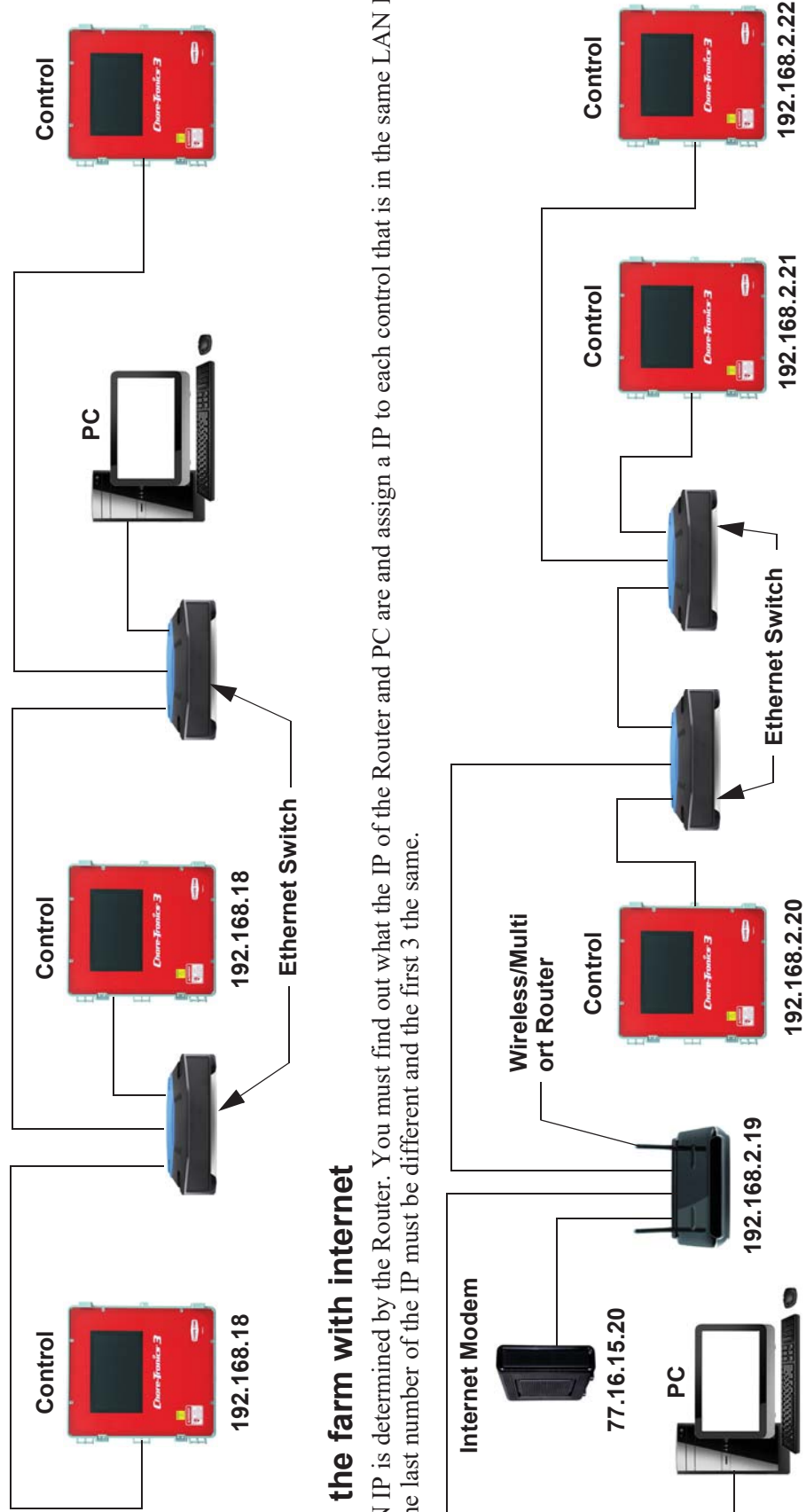

PC on the farm with internet

The LAN IP is determined by the Router. You must find out what the IP of the Router and PC are and assign a IP to each control that is in the same LAN IP range. The last number of the IP must be different and the first 3 the same.

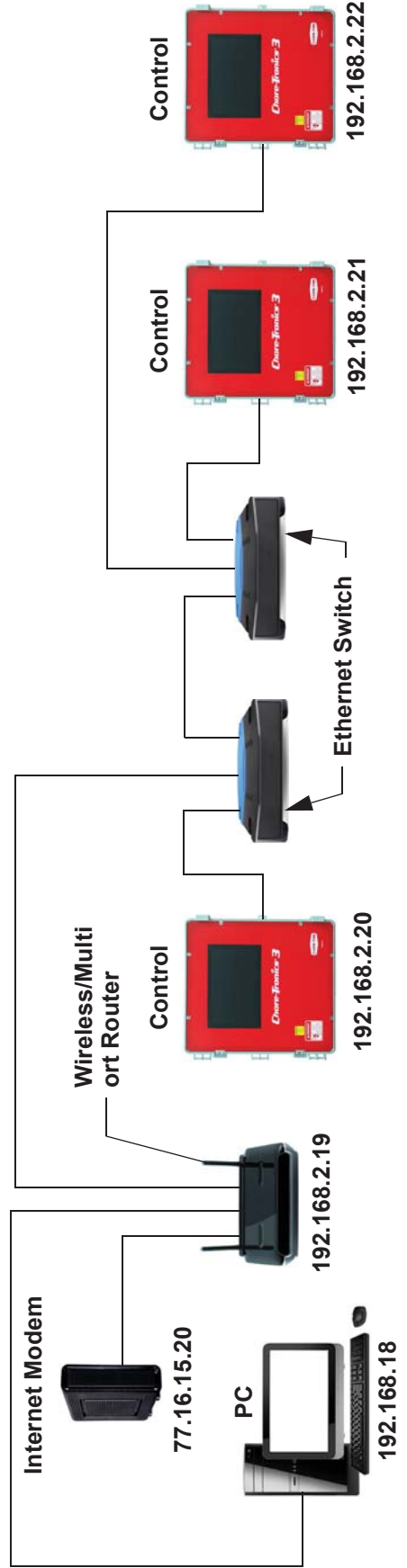

Troubleshooting

Programming Trouble Shooting

Table 1:

Problem	Possible Cause	Possible Solution
Can not lower set temperature below 32.0° F. and can not raise the set temperature above 120.0° F.	Normal set temperature range.	The Control has been set up so that set temperature range is between 40.0° F. and 120.0° F.
Have one Fan set to come on at 80°F and another Fan to come on at 80.3°F, but the Control won't accept the 80.3° setting.	Offsets too close.	There must be at a .5°F difference between any two Fan outputs. Two or more Fans may be set to come on at the same temperature. Heater outputs follow the same rules, however the cool out puts do not.
Fan(s) turns on, Mode Sensor(s) temperature is at set point.	<p>A.) Fan is assigned to a Timer.</p> <p>B.) Temperature Sensor(s) assigned to operate the Fan are different than the mode Sensor(s).</p> <p>C.) Fan's manual switch is set to the manual "on" position.</p> <p>D.) Bad Relay Module/MS Board.</p>	<p>A.) If Timer is not wanted on Fan remove the Timer in the "Outputs and Temperatures" screen.</p> <p>B.) Change Temperature Sensor(s) assignments in the Setup-General: Outputs Screen if desired.</p> <p>C.) Put manual switch in "automatic" position.</p> <p>D.) Replace Module/Board</p>
Fan(s) will not turn on when mode Sensor(s) reach the Fan's on temperature.	<p>A.) Fan's assigned Sensor(s) are different than the mode Sensor(s)</p> <p>B.) Fan is set to run in a different mode (example: Tunnel instead of Power).</p> <p>C.) Fan's manual switch is set to the "off" position.</p> <p>D.) Bad Relay Module/MS Board.</p>	<p>A.) Change Temperature Sensor(s) assignments if desired.</p> <p>B.) Go to the "Setup" screen and change modes of operation if desired.</p> <p>C.) Put manual switch in "automatic" position.</p> <p>D.) Replace Module/Board</p>

Table 1:

Problem	Possible Cause	Possible Solution
Fan(s) will not shut off.	<p>A.) Fan has not reached the “off” temperature.</p> <p>B.) Fan assigned Temperature Sensor(s) is different than mode Temperature Sensor(s).</p> <p>C.) Fan’s manual switch is set to the manual “on” position.</p> <p>D.) Bad Relay Module.</p> <p>E.) Back-up thermostat is overriding the Control.</p>	<p>A.) The Fan’s “off” temperature is the “on” temperature of the next Fan below it, or if desired you can program the "off" temperature.</p> <p>B.) Change Temperature Sensor(s) assignments in the Setup-General: Outputs screen if desired.</p> <p>C.) Put manual switch in “automatic” position.</p> <p>D.) Replace Module/Board.</p> <p>E.) Check setting of back-up thermostat and correct if necessary.</p>
Fan assigned to operate in Power Mode only is running in Natural Mode.	<p>A.) A “Pot Not Responding” or a “Pot Outside Limits” alarm has occurred.</p> <p>B.) Fan Switch in "Manual ON" position</p>	<p>A.) Find out cause of alarm and correct. Please see Potentiometer troubleshooting section for suggestions.</p> <p>B.) Move Switch to automatic</p>
Fan anticipation feature is not working.	<p>A.) Minimum Ventilation Fans assigned to something other than Minimum Ventilation Timer, or no Timer at all.</p> <p>B.) Other Fans (example: Stir Fans) are already operating due to temperature settings.</p>	<p>A.) All Fans intended for minimum ventilation must be assigned to the Minimum Ventilation Timer.</p> <p>B.) If any other Fans are operating at the time the Minimum Ventilation Timer reaches its On Time, the anticipation function is disabled.</p>

Programming Troubleshooting Continued.....

Table 2:

Problem	Possible Cause	Possible Solution
<p>Tunnel Curtain does not completely open when going into Tunnel Mode.</p>	<p>A.) If in the "Static Pressure" screen the high Control limit is set to something other than .00 under Tunnel Mode, than the Control will adjust the Tunnel Curtain for static pressure. B.) Limit Switches on Curtain machine are not set properly C.) Problem with Curtain and/or cabling.</p>	<p>A.) To stop Static Pressure Control on the tunnel, set the high static pressure limit to .00 under Tunnel Mode in the (Main Menu) "Static Pressure" screen. B.) Check limit switches and adjust as necessary. C.) Correct cabling and/or Curtain problem.</p>
<p>Tunnel Curtain opens completely before adjusting to static pressure.</p>	<p>A.) Tunnel Curtain speed and/or full movement distance improperly entered in the "Setup" screen B.) .00" static pressure setting in the (Main Menu) "Static Pressure screen".</p>	<p>A.) Correct Tunnel Curtain speed and/or full movement numbers. B.) Set desired static pressure settings for Tunnel Mode</p>
<p>Tunnel Curtain opens in Power Mode.</p>	<p>A.) Power-Tunnel Mode Transition. B.) High static pressure alarm safety feature has taken over. C.) Additional inlet area through the Tunnel Curtain feature has taken over.</p>	<p>A.) Normal Operation B.) Static pressure had quickly built to above 0.20” and stayed there for over the wind delay setting. Tunnel Curtain will open to maintain a static pressure of between 0.18 and 0.20.” This is usually accompanied by a high static pressure alarm. Find cause of high static pressure and correct. C.) Normal operation. Whenever the air Inlets do not provide enough air, the Tunnel Curtain will also open enough to maintain static pressure within the Power Mode limits.</p>

Programming Trouble Shooting Continued.....

Table 3:

When half-house brooding the Minimum Rel. alarm is continually going off. The Sensor(s) indicated are always in the non-brood end.	One or more non-brood end Sensors are assigned as Mode Sensors and/or there are non-brood sensors assigned to the power mode sensors in the Alarms Screen.	Remove non-brood Sensor(s) as Mode Sensors when brooding. Sensor(s) can still be assigned to heaters, etc. to keep non-brood end temperature above freezing.
It is a cool-breezy day, and when the Control goes into Natural Mode the Curtains open to the first opening position (example: 12 inches on a 48-inch Curtain). After about 30 seconds the Control goes back into Power Mode and the Curtains close right back up. It does this several times.	Normal Operation	If the temperature drops .6× F in the first two minutes, the Curtains are given a continuous close signal and the Control goes back into Power Mode. This is the quick temperature check as described in the Mode Transitions, " Power to Natural ", section of this Manual.

Equipment and Potentiometer Troubleshooting

Table 4:

Problem	Possible Cause	Possible Solution
Display difficult to read.	A.) Back light on display board unplugged or defective.	A). Check two wire plug on Display board. Replace if defective.
Display Completely Blank.	A.) Flat cable(s) between KB board and Display board is unplugged or defective. B.) Defective Display board. C.) Defective HI board. D.) Defective KB Board	A). Check flat cable connections. Replace cable if defective. B). Replace Display Board. C). Replace KD Board. D.)Replace KB Board

Table 4:

<p>The Control says that the pressure in the house is .00" and will not move.</p>	<p>There is a wire connection problem between the static pressure monitor and the IO board. When the static pressure monitor is disconnected from the IO Board the Control defaults to a reading of .00"</p>	<p>Check for wires being switched, broken wires, wires not making a good connection, etc. An easy way to remember the wiring is that the red wire is connected to the positive terminal of both the IO board and the static pressure monitor.</p>
<p>Temperature Sensor reading very low, but is not stuck on 0° F.</p>	<p>A.) Connections in Temperature Sensor junction box, and/or I/O Board have become loose and/or corroded. B.) Defective Temperature Sensor.</p>	<p>A.) Check all Temperature Sensor connections, correct any problems. B.) Replace Temperature Sensor.</p>
<p>Temperature Sensor reading very high or shows a “#” in place of a temperature reading.</p>	<p>A.) Moisture inside Temperature Sensor junction box causing short. B.) A Break in the Temperature Sensor wire is causing a short. C.) Defective Temperature Sensor.</p>	<p>A.) Remove moisture from Sensor box and recheck temperature. B.) Check Sensor wire and wire connections. Correct any problems. C.) Replace Temperature Sensor.</p>
<p>Temperature readings are not steady (changing half a degree or more every five seconds). It is causing Tunnel Fans and heaters to run at the same time.</p>	<p>There is excessive noise on the Temperature Sensors. This can be caused by not using a Twisted Pair Wire for the Temperature Sensor, running the Sensor wire inside conduit with high voltage wire, or using a shielded wire and grounding the shield.</p>	<p>To prevent noise from both-ering the Sensors, use non-shielded Twisted Pair Wire (part no. 42208) and run the wire by itself away from high voltage wires. Preferably the wire should also enter the Control in a separate place from the high voltage wire, but this is not always possible. Do not use Romex, SJO cord, shielded wire, etc. as Temperature Sensor wire.</p>

Equipment and Potentiometer Troubleshooting Continued.....

Table 5:

Problem	Possible Cause	Possible Solution
Water meter not recording.	<p>A.) Loose connection on Water Meter and/or I/O Board on Chore-Tronics® 3.</p> <p>B.) Wrong type of Water Meter.</p> <p>C.) There is excessive noise on the Water Meter. This can be caused by not using a Twisted Pair Wire for the Water Meter, running the Water Meter wire inside conduit with high voltage wire, or using a shielded wire and grounding the shield.</p> <p>D.) Faulty I/O Board.</p> <p>E.) Faulty Water Meter.</p>	<p>A.) Check connections and correct.</p> <p>B.) Make sure Water Meter is a dry contact pulsed Water Meter (Chore-Time part no. 13228-GP) and that the pulser unit is working correctly.</p> <p>C.) To prevent noise from bothering the Water Meter, use non-shielded Twisted Pair Wire part no. 42208) and run the wire by itself away from high voltage wires. Preferably the wire should also enter the Control in a separate place from the high voltage wire, but this is not always possible. Do not use Romex, SJO cord, shielded wire, etc. as Water Meter wire.</p> <p>D.) Replace I/O Board.</p> <p>E.) Replace/repair Water Meter.</p>
Low Water pressure switch alarm going off constantly but water pressure is NOT low.	<p>A.) Wrong style or pressure switch.</p> <p>B.) Bad or loose connection on water pressure switch and/or I/O Board on the Chore-Tronics® Control.</p> <p>C.) Faulty switch.</p>	<p>A.) Switch needs to be a reverse action low water pressure switch (Chore-Time part no. 46597).</p> <p>B.) Check connections and correct.</p> <p>C.) Replace switch.</p>

Table 5:

<p>I2C Alarm.</p>	<p>A.) Loose, mis-align, or defective flat cable. B.) Defective I/O, I2C, or Expansion Board. C.) Expansion Board address Dip Switches set incorrectly.</p>	<p>A.) Check all flat cables and correct or replace as necessary. B.) Replace Defective Board. C.) See “Expansion Board Installation/Wiring” on page 111 for correct Dip Switch settings.</p>
<p>MS Board not functioning correctly, or outputs not functioning correctly.</p>	<p>A.) The DIP switches found on the side of the MS board are in the wrong position. B.) Defective MS Board or Relay Module. C.) Poor I/O NET Connection. between the Relay Box and Main. Box, or between MS Boards.</p>	<p>A.) Replacement boards come from the factory with all three DIP switches in off position. If you have an MS board operating switches 17-32 or 33-40 then the DIP switches need to change positions. See “MS Board Dip Switch Positions” on page 116. B.) Replace Board. C.) Check I/O Net Connection.</p>
<p>The lights above the manual switches are dimmer when on in the automatic mode than in the manual mode. Also Lights flash bright for a second in automatic mode.</p>	<p>Normal Operation.</p>	<p>The indicator light is wired directly across the coils of the Output Relay. When the switch is placed in the manual on position the full 24 volts are placed on the coil, causing the light to glo bright. When the Relays are told to come on by the Control in automatic the full 24 volts is applied to pull the contacts in. The voltage is then reduced to hold the contacts in. This causes the light to glo dim. When the Relays are on in automatic mode, the Control occasionally puts full voltage across the coils to assure the Relay is still engaged.</p>

Equipment and Potentiometer Troubleshooting Continued.....

Table 6:

Problem	Possible Cause	Possible Solution
Relays are constantly failing.	A.) Relays are overloaded. Maximum is 1HP. B.) There is a short in the wiring connected to that Relay. C.) One of the stand-offs holding the Relay module is broken and is causing the board to touch the back plate. D.) Voltage from Back-up Thermostat is wrong phase of 220.	A.) Reduce load on Relays. B.) Find problem in wiring and correct. C.) Replace stand-off. D.) Connect other Phase of 220 to Back-up Thermostat.
Pot not responding alarm (internal pot) .	A.) Gear not making contact with screw. B.) Gear set screw not tight on Potentiometer shaft. C.) Potentiometer not connected to Control and/or bad connection between Potentiometer and Control. D.) Bad Potentiometer. E.) First Opening movement too small.	A.) Loosen Potentiometer assembly mounting bolts and slide until gear makes contact with the screw. B.) Tighten gear set screw. C.) Connect Potentiometer to the Control and/or look for bad connection and correct. D.) Replace Potentiometer. E.) Make Sure that the first opening movement causes at least a 10-count change Potentiometer reading.

Equipment and Potentiometer Troubleshooting Continued.....

Table 7:

<p>Pot not responding alarm (external pot)</p>	<p>A.) Main Curtain cable and/or Potentiometer cable caught, or broken.</p> <p>B.) Return spring frozen or broke inside Potentiometer assembly.</p> <p>C.) Potentiometer not connected to Control and/or bad connection between Potentiometer and Control.</p> <p>D.) Bad Potentiometer.</p> <p>E.) First Opening movement too small.</p>	<p>A.) Make sure that both the Main Curtain cable and the Potentiometer cable can move freely. Make sure Potentiometer cable does not drag on grommet. Make sure there is adequate weight to keep Main Curtain cable taught.</p> <p>B.) Check Cable wrap on wheel. Repair or replace spring.</p> <p>C.) Connect Potentiometer to the Control and/or look for bad connection and correct.</p> <p>D.) Replace Potentiometer</p> <p>E.) Make Sure that the first opening movement causes at least a 10-count change Potentiometer reading.</p>
<p>Pot outside limits alarm (internal pot).</p>	<p>A.) Potentiometer has not been calibrated (especially new installations).</p> <p>B.) Gear not making contact with screw.</p> <p>C.) Limit switch(es) has been moved on the Curtain machine.</p> <p>D.) Potentiometer not connected to Control and/or bad connection between Potentiometer and Control.</p> <p>E.) Bad Potentiometer.</p>	<p>A.) Go to the "Setup" screen and scroll down to the Main Curtain calibration to set up the open and close limits of the Curtain.</p> <p>B.) Loosen Potentiometer assembly mounting bolts and slide until gear makes contact with the screw.</p> <p>C.) If limit switches have been moved, then re-calibration is required.</p> <p>D.) Connect Potentiometer to the Control and/or look for bad connection and correct.</p> <p>E.) Replace Potentiometer.</p>

Equipment and Potentiometer Troubleshooting Continued....

Table 8:

<p>Pot outside limits alarm (external pot).</p>	<p>A.) Potentiometer has not been calibrated (especially new installations).</p> <p>B.) Potentiometer cable is wrapping around the Main Curtain cable.</p> <p>C.) Limit switch(es) has been moved on the Curtain machine.</p> <p>D.) Potentiometer not connected to Control and/or bad connection between Potentiometer and Control.</p> <p>E.) Bad Potentiometer.</p>	<p>A.) Go to the Setup screen and scroll down to the Main Curtain calibration to set up the open and close limits of the Curtain.</p> <p>B.) Unwrap Potentiometer cable from main cable. Consider installing Anti-twist balls to keep Potentiometer cable from wrapping, or possibly change how the pot cable attaches to the main cable.</p> <p>C.) If limit switches have been moved, then re-calibration is required.</p> <p>D.) Connect Potentiometer to the Control and/or look for bad connection and correct.</p> <p>E.) Replace Potentiometer.</p>
<p>Pot reading is not stable (changing more than 3 counts when the Curtain machine is not running).</p>	<p>A.) Did not use Twisted Pair Wire.</p> <p>B.) Ran Potentiometer wire close to, or in same conduit with high voltage lines.</p>	<p>A.) Make sure that the wire used to connect the Potentiometer to the Control is a twisted pair unshielded wire.</p> <p>B.) Keep Potentiometer and Temperature Sensor wire away from high voltage lines. When high voltage lines must be crossed, be sure to cross as close to 90 degrees as possible.</p>

IONet Error Addr:xx

This is a communication failure between the Main box and 1 or more of the Manual Switch Boards (iMSCM). The number following the address indicates which board is having the communications issues. These trouble shooting steps assume that the I/O Net alarm occurred on a previously functioning control and no boards have been replaced. Do the following steps:

1. Clear the alarm. See if it reappears in approx. 30 seconds. Check to make sure the same board address appears. If the same address appears go to Step 2. If the I/O Net alarm does not appear at all or the alarm does occur, but at a different address go to Step 3.
2. Open the door to the Relay Box and remove the protective cover plate. **Caution: Line voltage will be present!** Check the light in the center of the switch board where the I/O Net alarm occurred to see if it is flashing (normal operation). If the light is flashing go back to Step 1. If the light is not flashing go to Step 4.
3. Power off the Control. Check the polarity of the twisted pair that is connected to the I/O Net terminals in both the main box and the relay box **Caution: Line voltage will be present!** Also, check the polarity of the 24 Vdc Twisted Pair in both the Main Box and the Relay Box. Correct if necessary. If the I/O Net alarm is still occurring go to Step 4.
4. Check to make sure that the #1 DIP switch on the IO Board of the Main Box is set to the ON position for 32 and 40 output Controls or to the OFF position for 56 outputs Controls. For all Controls, check that the jumper in the upper right hand corner of the Switch Board closest to the bottom is set to the ON position. Correct if necessary. If the I/O Net alarm is still occurring go to Step 5.
5. Check the routing of the Twisted Pair wire for both the I/O Net and the 24 Vdc. Make sure that Twisted Pair wire is used, the wires are run separately from line voltage wires, and that when the pair does cross line voltage wires it is at a 90 degree angle. Correct if necessary. If the I/O Net alarm is still occurring go to Step 5.
6. Check the grounding of the Control. There should be one ground wire connected from Earth ground to the Ground Rail of the Main Box of the Control. There then should be a ground wire connecting the ground rail of the Main Box to the Ground Rail of the Relay Box. Correct if necessary. If the I/O Net alarm is still occurring go to Step 6.
7. Remove power from the Control. Open the Relay Box and remove the protective cover plate. Check all the terminals of all boards that have had an I/O Net alarm occur. Make sure that all wires from the wiring harness are securely in the correct terminal position and that the screws are tight. Correct if necessary. If I/O Net alarm is still occurring go to Step 8.
8. Replace the Switch Board.

Wiring Diagrams

Backup Control Wiring (24Vdc)

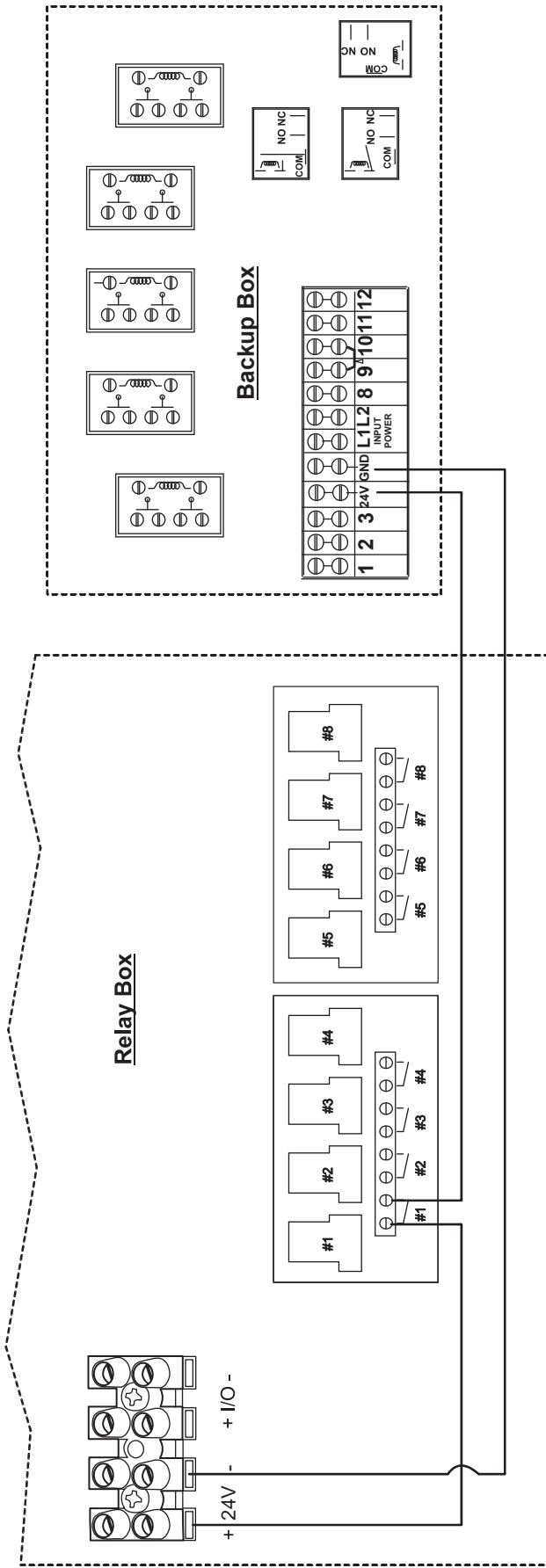
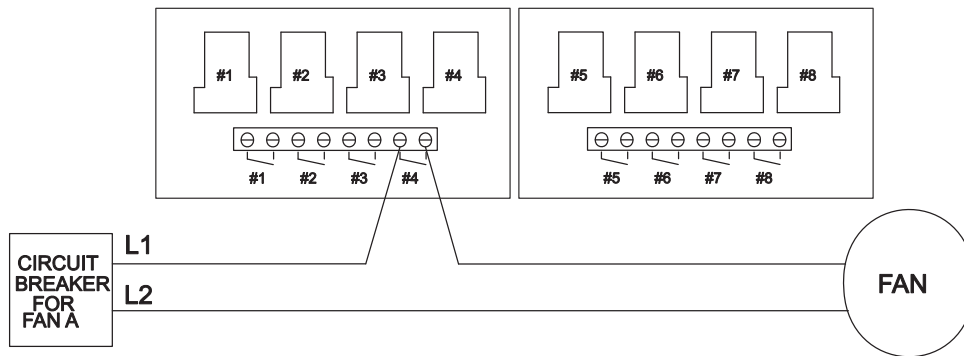

Figure 44. Backup Box Wiring

Fan Wiring

TYPICAL WIRING OF OUTPUT RELAYS



ALL OUTPUT RELAYS ARE SPST WITH DRY CONTACTS AS SHOWN. THIS SHOWS A TYPICAL SITUATION WHERE A FAN HAS BEEN ASSIGNED TO RELAY 4 IN THE SETUP SCREEN.

NOTE: EACH RELAY'S CONTACTS ARE CLOSED WHEN THE OUTPUT THAT IS ASSIGNED TO THAT RELAY IS SUPPOSED TO BE ON.

Figure 45. Fan Wiring

Linear Lift Wiring Diagram

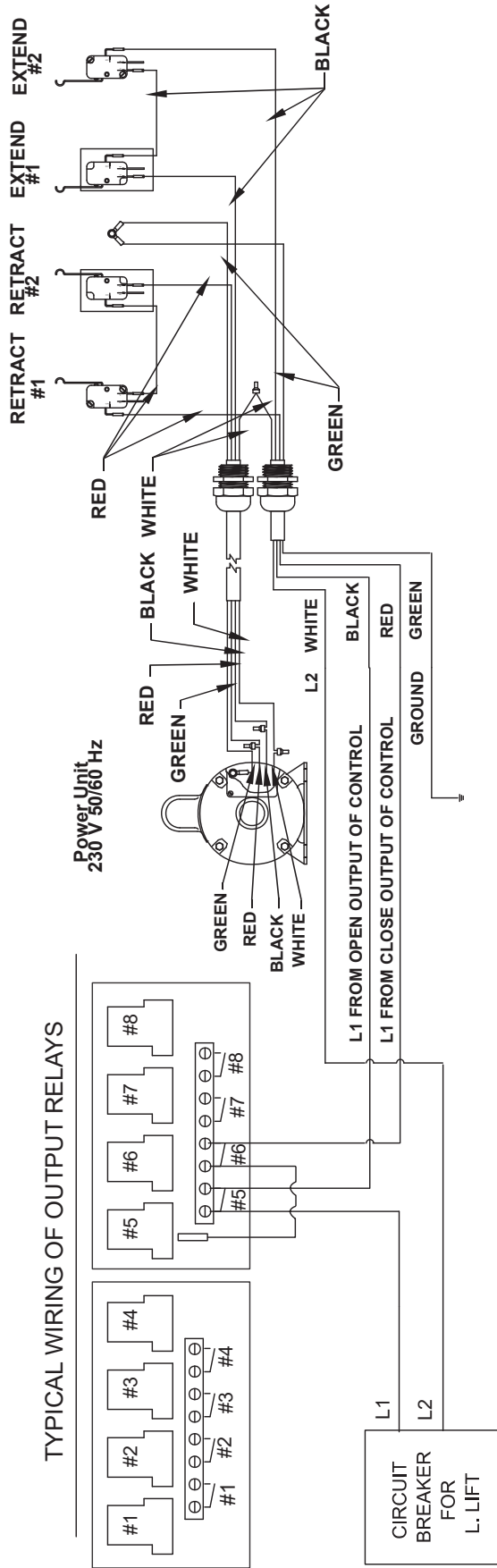

NOTE: THIS ASSUMES THE LINEAR LIFT OPENS THE INLET WHEN IT EXTENDS AND CLOSES THE INLET WHEN IT RETRACTS

Figure 46. Linear Lift Wiring

Turbo-Cool™ Wiring

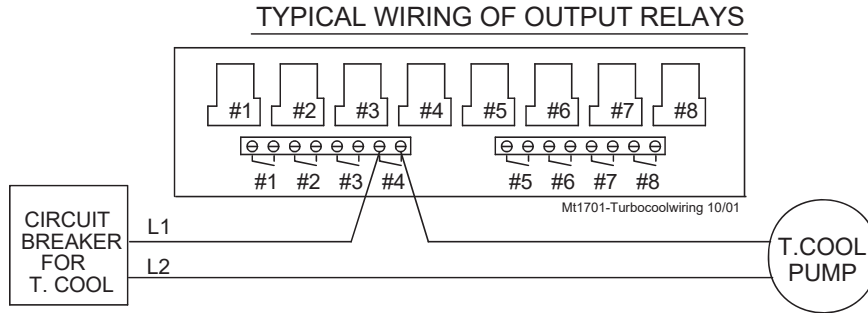

ALL OUTPUT RELAYS ARE SPST WITH DRY CONTACTS AS SHOWN. THIS SHOWS A TYPICAL SITUATION WHERE THE TURBO COOL PUMP HAS BEEN ASSIGNED TO RELAY 4 IN THE SETUP SCREEN.

NOTE: EACH RELAY'S CONTACTS ARE CLOSED WHEN THE OUTPUT THAT IS ASSIGNED TO THAT RELAY IS SUPPOSED TO BE ON.

Figure 47. Turbo-Cool Wiring

I/O Board Wiring

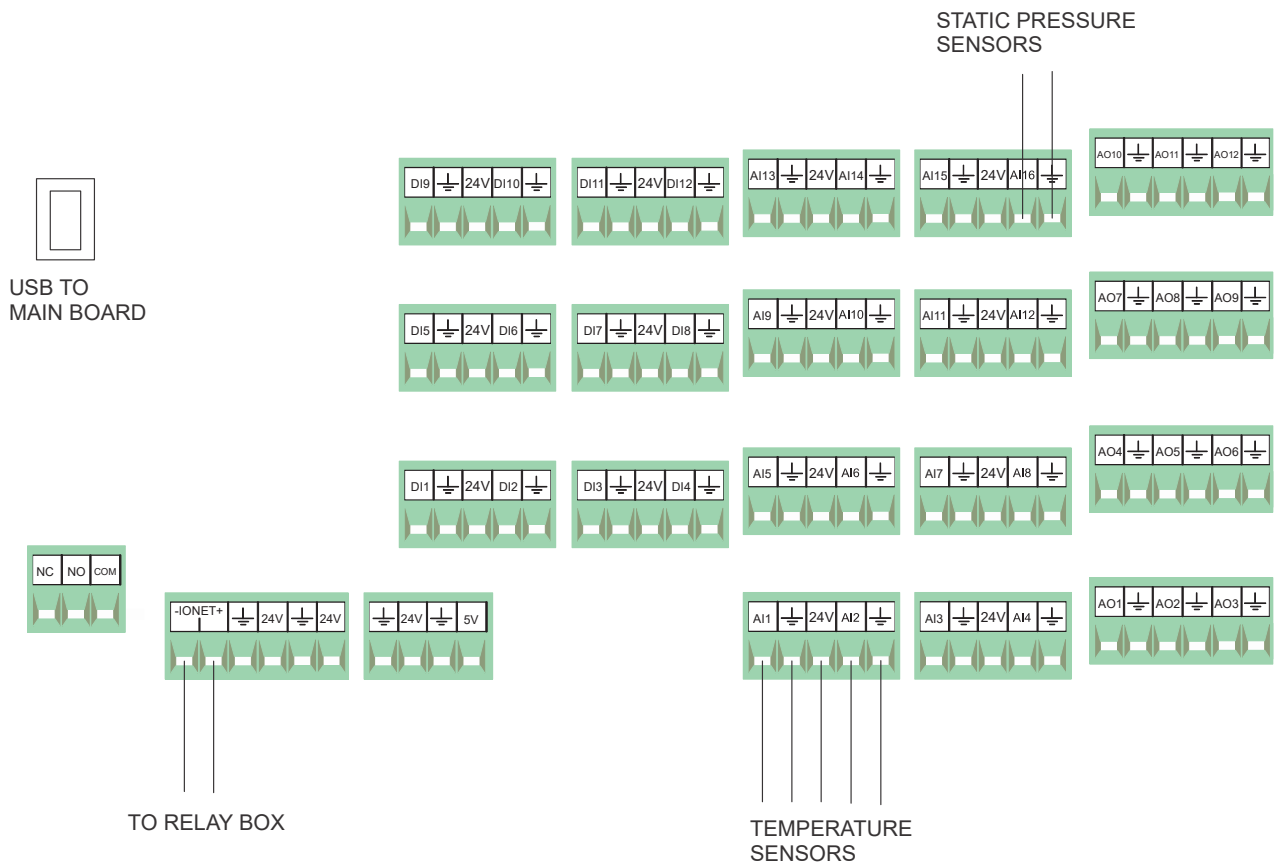
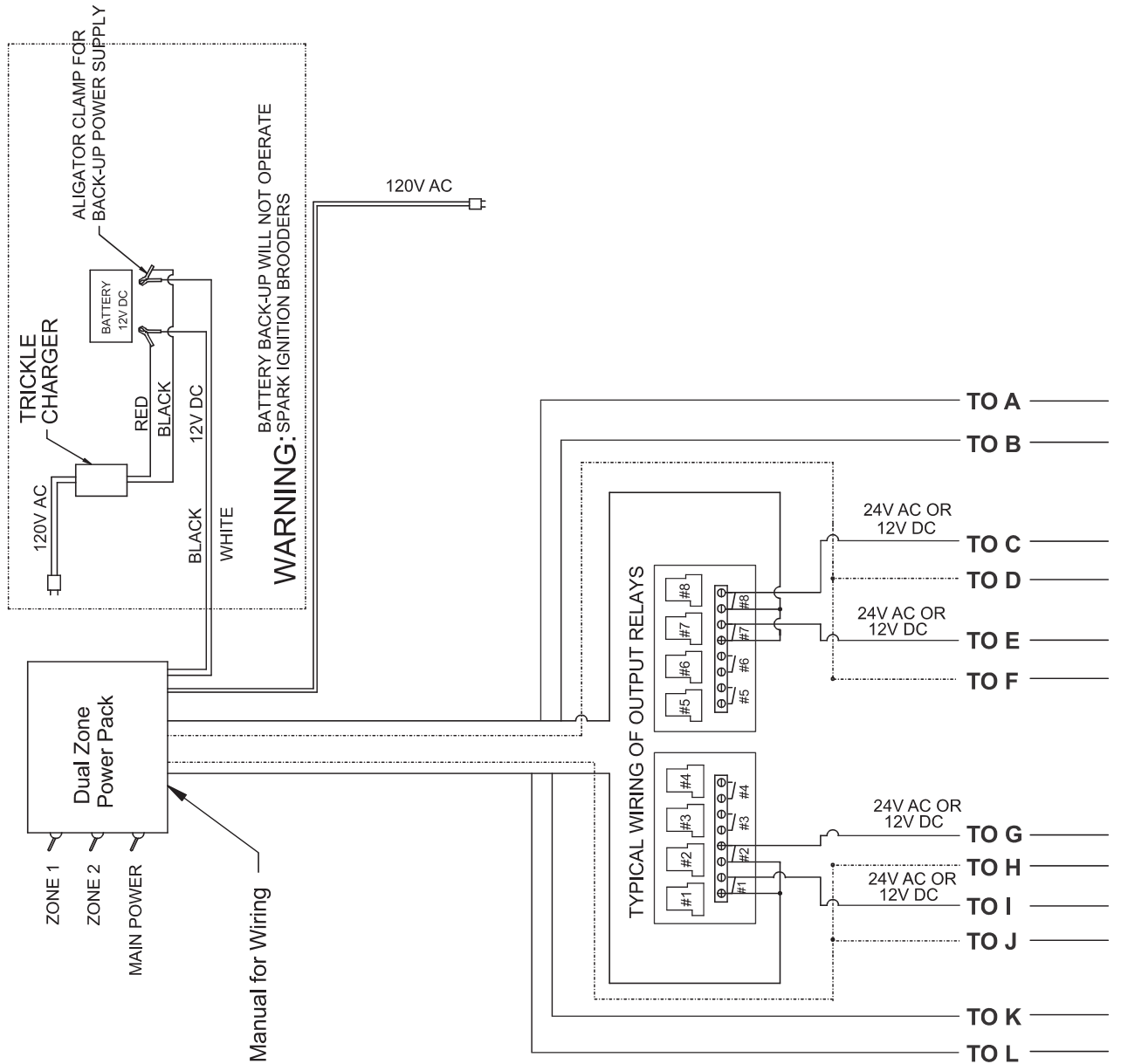

Figure 48. I/O Board Wiring

This page left blank intentionally.....

Brooder Wiring



ial Zone Power Pack Manual for Wiring

2398-350 11/13

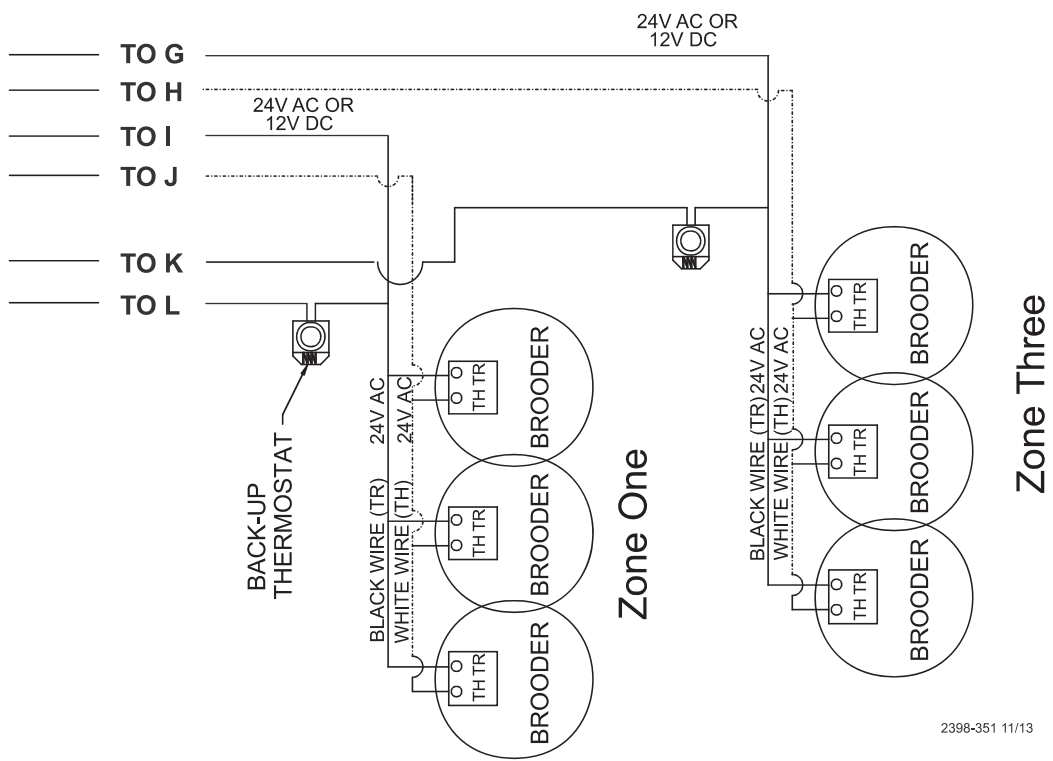
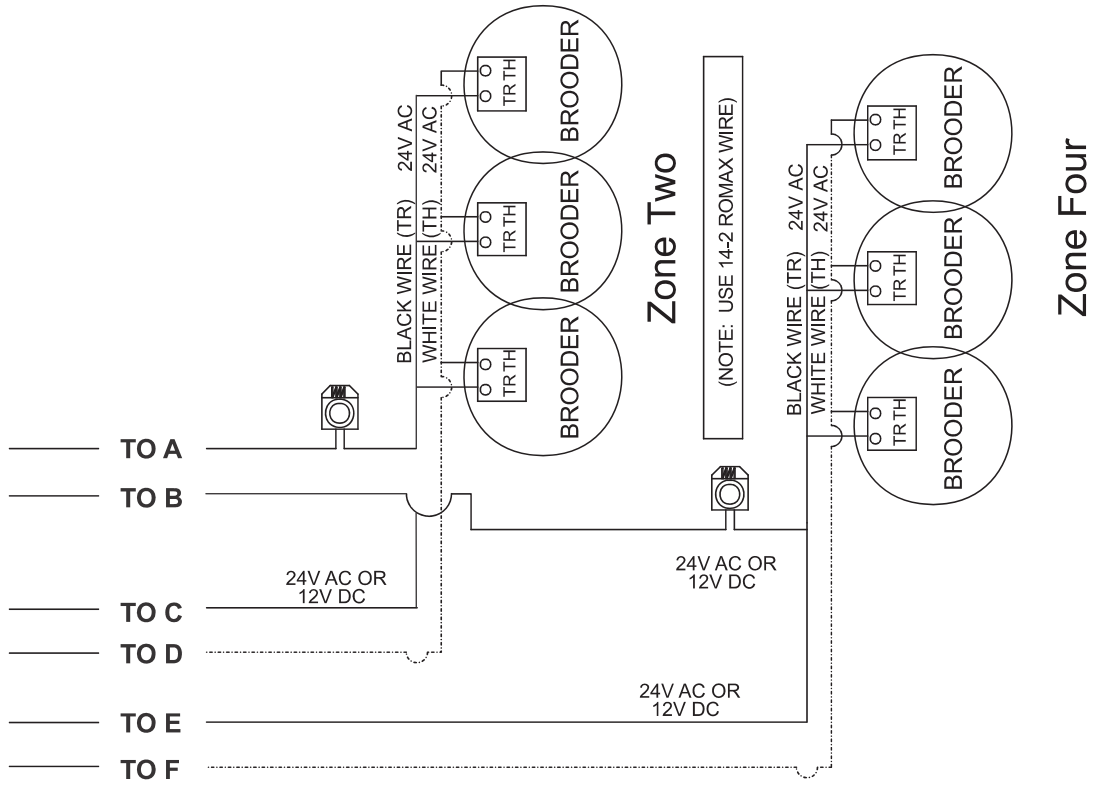

2398-351 11/13

Improving Lightning Surge Suppression

Lightning can be a very destructive and expensive phenomenon. It does not always take a direct “hit” for lightning to cause extensive damage to electrical equipment. The Chore-Tronics® 3 Controls do have components that help suppress and/or isolate power surges such as lightning. These components many times will protect the controls from the power surge or at least keep the damage isolated to one board on the control. However, more direct strikes or strikes that hit network wires such as alarm wires to phone dialers or the C-Central network can cause damage to numerous boards in numerous controls. If the farm is located in a lightning prone area or if there is a network of wires connecting all Chore-Tronics® Controls together (such as C-Central or an alarm system), then additional lightning protection should be considered. These products are available from Chore-Time. The products available will be discussed later in this section. It should also be noted that a back-up system consisting of mechanical back-up thermostats be installed in the event of a control failure. Chore-Time has a back-up box available (Part Number 40727).

Before obtaining lightning suppression devices, first check the system grounding of each house/room. Every building needs to have its own ground rod and that ground rod must be driven deep enough into the ground that it will have good contact year round. Please check with the local electrician and/or electrical inspector for specific ground rod requirements in your area. In some areas one ground rod may not be sufficient to provided a good ground to earth, in that case an electrician should be consulted to find alternate ways of obtaining a good Earth ground. Again, be sure to check with a qualified electrician for grounding requirements.

Once a good grounding system has been established, if lightning is still a concern, surge suppressors should be considered. It is recommended that there be a suppressor installed at the main distribution panel for the farm (Chore-Time Part Number 47663) and a suppressor installed on the service panel of each house/room (Part Number 47662). If C-Central and/or an alarm system is used then there should be a low voltage suppressor (Part Number 47660) installed at every control and a telephone line suppressor (Part Number 47661) installed at the phone line on the farm. **See Figures 50 through 52** on the following pages for the wiring diagrams and more information on location and installation of these devices.

Installing these devices does not guarantee that the farm will not be struck by lightning or that equipment will not be damaged from lightning strikes. However, they will greatly increase the amount of protection already there, and thus will reduce the chances of having lightning damage occur.

47663 Farm Main Service Panel Surge Suppressor Wiring Diagram

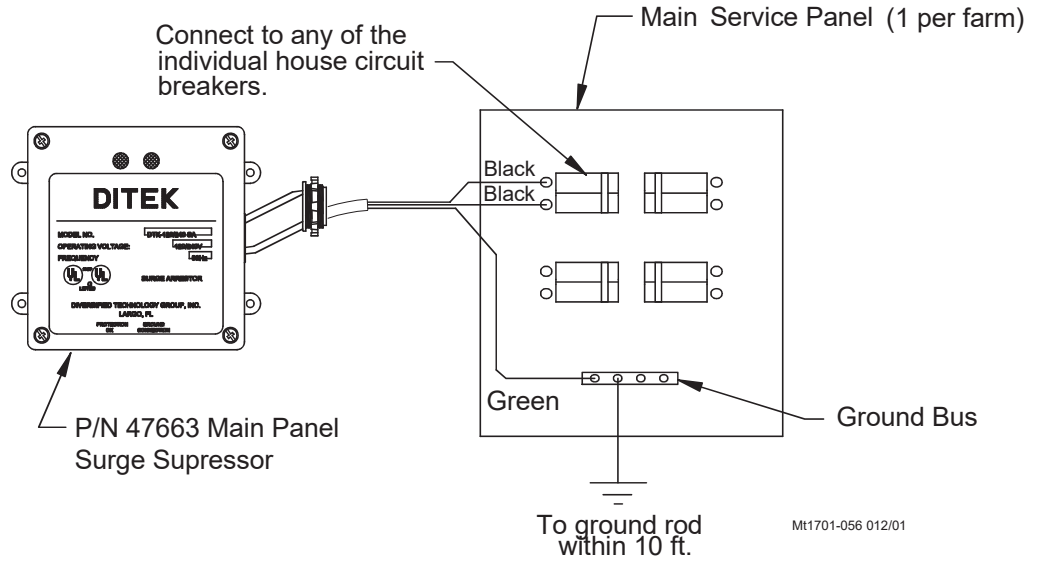

Figure 50. Service Panel Surge Suppressor Wiring

47662 House Main Service Panel Surge Suppressor Wiring

Can be Connected to existing 220 Breaker or you can use a Breaker dedicated to the Surge Suppressor

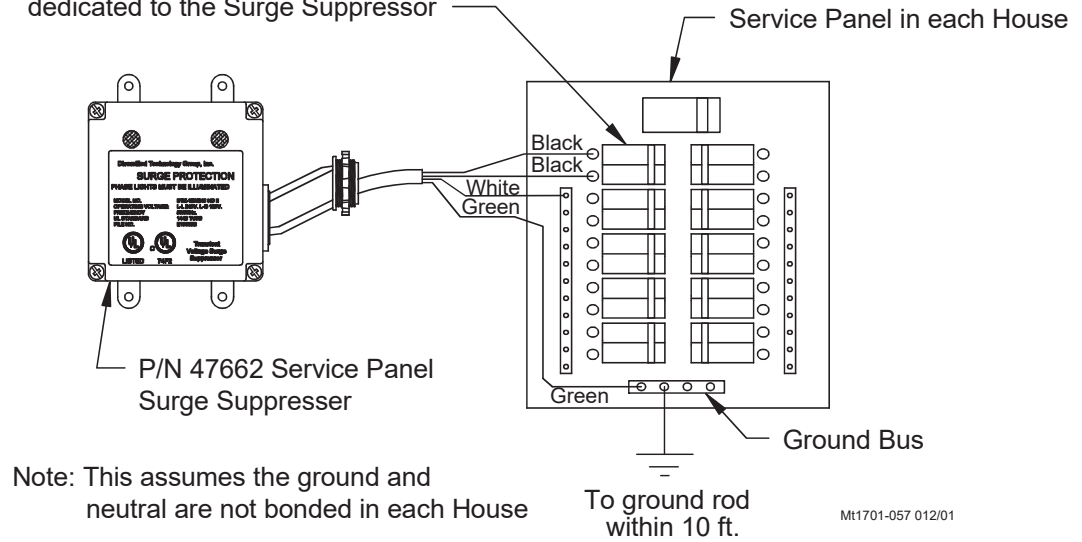
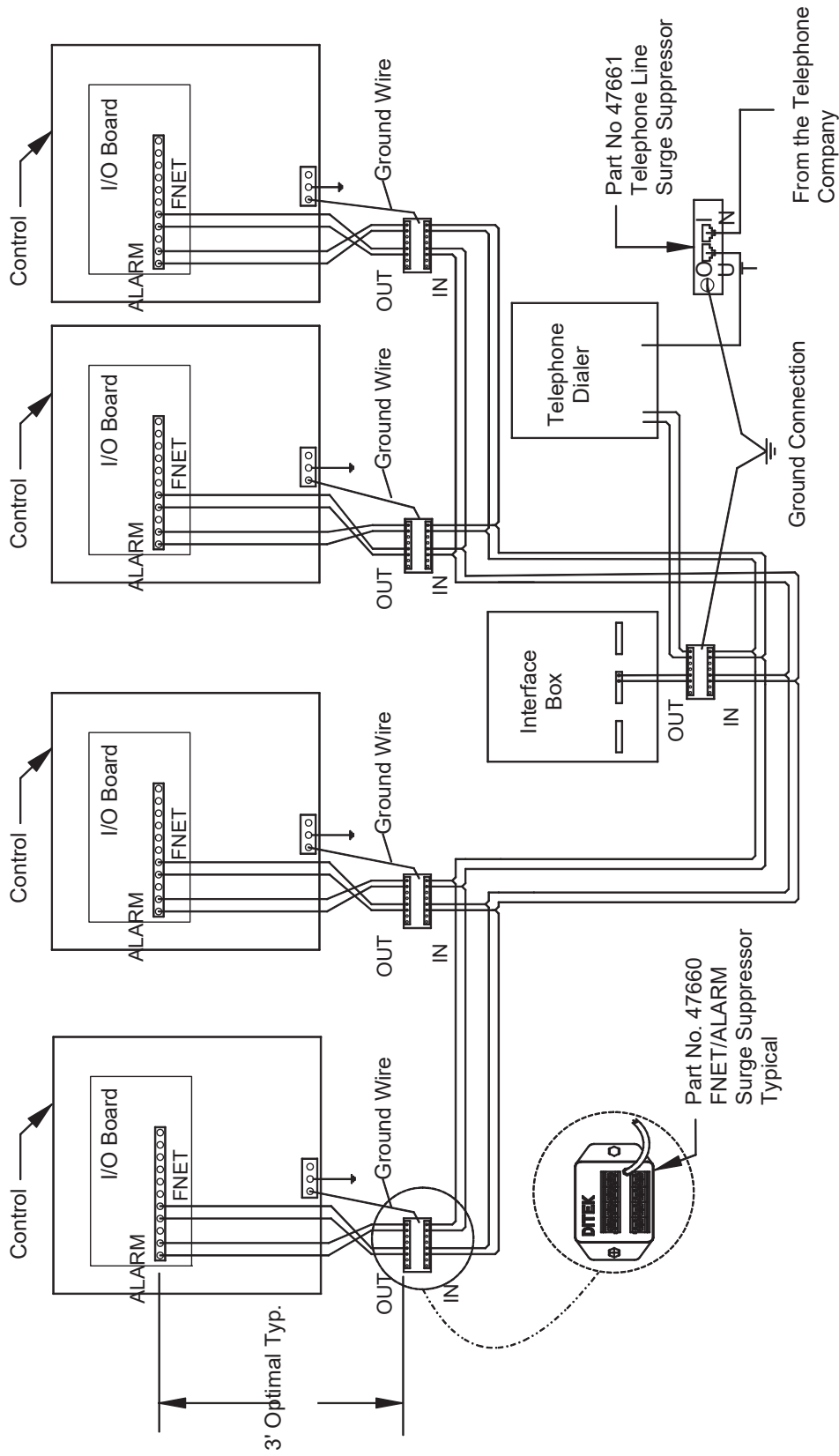

Figure 51. Main Service Panel Surge Suppressor Wiring

47660 FNET/ALARM & 47661 Telephone Line Surge Suppressor Wiring



Note: There must be a ground rod within 10 ft. of the Ground Terminal of each Surge Suppressor. The wire size from the Suppressor to the ground rod should be 12 gauge or larger.

Figure 52. FNET Alarm and Telephone Line Surge Suppressor Wiring

This page left blank intentionally.....

Itemized Parts (Main Box)

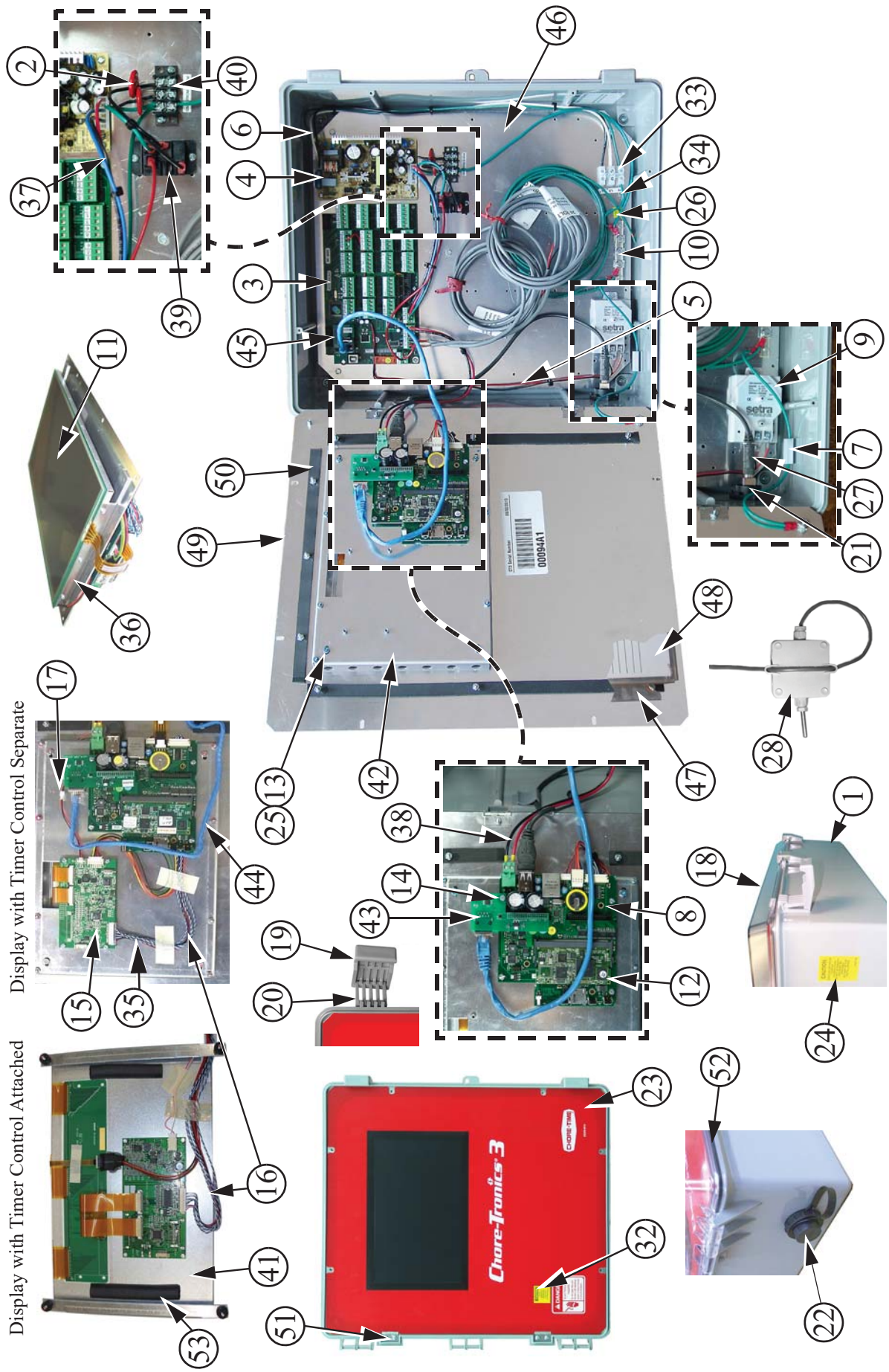

Display with Timer Control Attached

Display with Timer Control Separate

Parts Listing (Main Box)

Item	Description	Part No.	Item	Description	Part No.
1	Electric Box 14 x 16	42684	28	Temperature Sensor	40741
2	275V MOV	14063-1	29	Liquid Tight Connector 3/8" (Not Shown)	13477
3	I/O Board (CT3 replacement)	53332-485	30	Liquid Tight Connector 1/2" (Not Shown)	23779
4	Power Supply	49649	31	Conduit Locking Nut (Not Shown)	3357
5	Static Pressure Harness	53292	32	Caution Decal	2527-51
6	Incoming Power Cable	53333	33	Terminal Strip 3-Pole 1.24"	34925-3
7	Ribbon Cable Clamp	50130	34	Input Power Decal	2526-428
8	Carrier Board (CBM)	51845	35	LED Cable (For Repair)	53328
9	Static Pressure Sensor	44743	36	Touch Screen Mounting Bracket	52585
10	Grounding Rail	43384-2	37	Power Cable	53293
11	Display	53754	38	IO to CBM Cable	51857
12	SBC Board	53755	39	24V DC Coil Relay	42509
13	4-40 Hex Nut	3511	40	3 Position Terminal Strip	26862
14	Nylon Spacer (KD Board)	43382	41	Display W/TCON (For Repair)	51847-1
15	TCON Board (Timer Control)	51849	42	Plate CT 3 CBM Mounting	54131
16	CT3 LVDS Cable (For Repair)	54193	43	CT 3 RS 485 CBM Converter Board	54293
17	Back Light Cable (For Repair)	51851	44	Cable 24 in. Ethernet	54364
18	Electric Box Lid 14" x 16"	42683	45	CT3 RS 485 IOM Converter Board	54294
19	Control Box Latch	30862	46	Bottom Plate	52601
20	Latch Pivot	30863	47	Cover Plate	51856
21	USB External Port	51852	48	Input Cover Plate Decal	2526-538
22	USB External Port Cap	51873	49	Front Plate	51855
23	Main Decal	2529-915	50	Foam Tape (3.25')	48425
24	Caution Decal	2527-62	51	Aluminum Hinge	49482
25	.05" Spacer	43381	52	.125 Neoprene Seal (4.76')	34767
26	Ground Symbol Decal	2527-63	53	.5 x .36 Weatherstripping	50029
27	USB Cable	51853			

Itemized Parts (Relay Box)

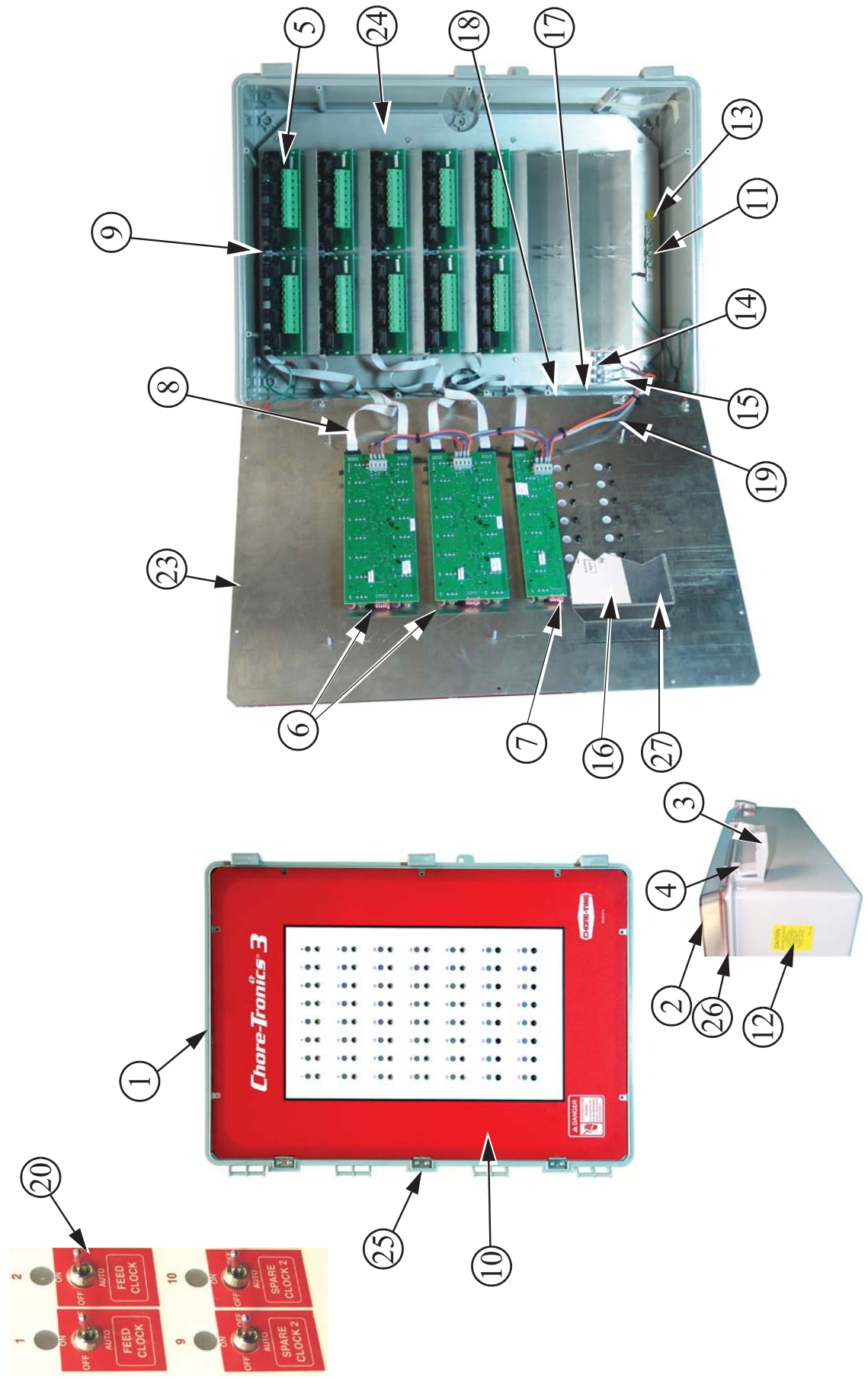

Parts Listing (Relay Box)

Item	Description	Part No.	Item	Description	Part No.
1	Electric Box 15 x 22	51466	16	Decal, Relay assigned to	2526-505
2	Electric Box Lid	51467	17	Hole Placement Decal	2527-72
3	Control Box Latch	30862	18	Ribbon Cable Clamp	50130
4	Latch Pivot	30863	19	56 Relay Cable	52536
5	Relay Board (RM4)	51861		40/48 Relay Cable	53505
6	Relay Board (IMSCM16)	49673		32 Relay Cable	53504
7	Relay Board (IMSCM8)	49672	20	Switch Sticker Decal	2529-684
8	Flat Cable 10P-380mm	48738	21	Ground Wire (17") (Not Shown)	52560
9	Flat Cable 10P-51mm	52535	22	Ground Wire (11") (Not Shown)	52561
10	CT3 Relay Box Decal	2529-916	23	Top Plate	51858
11	Grounding Rail 3.15"	43384-2	24	Relay Mount	52534
12	Caution Decal	2527-62	25	Aluminum Hinge	49482
13	Ground Decal	2527-63	26	.125 Neoprene Seal (6.5')	34767
14	Terminal Strip (4 Pole)	34925-4	27	Cover Plate	52716
15	Terminal Strip Decal	2526-439			

Extra Parts and Kits

Analog Input Add-On Kit (Part No. 49663)

Item	Description	Part No.
1	SRS Board Spacer	48742
2	#6-32 x .5" Phil. Pan Head Screw	35367
3	AI.4 Analog Input	49664
4	AI.4 Terminal Strip Decal	2526-461

Digital Input Add-On Kit (Part No. 49665)

Item	Description	Part No.
1	SRS Board Spacer	48742
2	#6-32 x .5" Phil. Pan Head Screw	35367
3	DI.4 Analog Input	49666
4	I/O Terminal Strip 6 Decal	2526-455

Expansion Board Kit (Part No. 49667)

Item	Description	Part No.
1	SRS Board Spacer	48742
2	#6-32 x .5" Phil. Pan Head Screw	35367
3	12C Board	49668
4	10 Pin 250mm Flat Cable	48760

IMSCM.8 Red Repair Board (Part No. 49672)

Item	Description	Part No.
1	IMSCM.8 Red Board	49656
2	.75 x .75 Closed Cell Sponge	49244

IMSCM.16 Red Repair Board (Part No. 49673)

Item	Description	Part No.
1	IMSCM.16 Red Board	49645
2	.75 x .75 Closed Cell Sponge	49244

Technical Specifications

Ambient Operating Temperature Range... 14°F (-10°C) to 122°F (50°C)

Set Temperature Range.... 32°F (4.4°C) to 120°F (48.9°C)

Timer Ranges....

Timer 1 & Timer 2: 0 to 2000 seconds on/0 to 2000 seconds off.

Min Vent Timer: 30-2000 or 0 seconds on/60-2000 or 0 seconds off.

Stir On Time: 0-Min Vent off time.

Supply Voltage.....85-264 Vac 50-60hz

Output Relays

Contacts.....SPST Normally Open Contacts

Voltage.....250 Vac max

Load.....1 HP@ 240

.5 HP @ 120 Vac

1000 W Incandescent Light Load @ 120 Vac

External Power Output

Voltage.....24 Vdc +/- 1.5V

Temperature Sensors

NTC Thermister range: -30°C to 50°C/-22°F to 122°F; 10 Kilo ohms @ 77°F +/- .7°F

Sensor Wire / PC Wire.....20 gauge single Twisted Pair Wire, 1 twist every 2 inches, unshielded wire. Use of Chore-Time part number 42208 strongly recommended.

Potentiometer (2-wire)..... 0-10KW 10-turns (Natural Ventilation Only)

Static Pressure Sensor (3-wire).....0-.4 inches w.c. range
0-10v (with resistor installed)

Relative Humidity Sensor (3-wire).....0-100% RH range
0-5 V signal

Pulsed Water Meter (2-wire).....Closed contact trigger, No voltage Input

Low Water Pressure Switch.....Low Pressure Reverse-Action Switch.
Settings (on/off) 10/5 PSIG

FNET Data Voltage Range (C-Central)..... +/-5 V

Alarm Relay

Voltage.....30 Vac
50 Vdc

Current.... .5 A @ 30 Vac
.5 A @ 30 Vdc

This page left blank intentionally.....



Chore-Tronics® 3

Note: The original, authoritative version of this manual is the English version produced by CTB, Inc. or any of its subsidiaries or divisions, (hereafter collectively referred to as "CTB"). Subsequent changes to any manual made by any third party have not been reviewed nor authenticated by CTB. Such changes may include, but are not limited to, translation into languages other than English, and additions to or deletions from the original content. CTB disclaims responsibility for any and all damages, injuries, warranty claims and/or any other claims associated with such changes, inasmuch as such changes result in content that is different from the authoritative CTB-published English version of the manual. For current product installation and operation information, please contact the customer service and/or technical service departments of the appropriate CTB subsidiary or division. Should you observe any questionable content in any manual, please notify CTB immediately in writing to: CTB Legal Department, P.O. Box 2000, Milford, IN 46542-2000 USA.

Revisions to this Manual

Page No.	Description of Change	
143	Changed 49738 to 48738	33629
	Updated Contact information cover page and back page.	

**For additional parts and information, contact your nearest Chore-Time distributor or representative.
Find your nearest distributor at: www.choretime.com/contacts**

Chore-Time Group, A division of CTB, Inc.
PO Box 2000
Milford, Indiana 46542-2000 USA
Phone (574) 658-4101 Fax (877) 730-8825
Email: choretime@choretime.com
Internet: www.choretime.com