

CONSTRUCTION MANUAL



6', 7', and 9' [1 829, 2 134, and 2 743 mm] Dia. HOPPER BINS



Warranty

Brock Grain Systems (“BROCK”) warrants each new BROCK® Commercial Grain Bin* manufactured by it to be free from defects in material or workmanship for five years from and after the date of initial installation by or for the original purchaser. If such a defect is found by the Manufacturer to exist within the five-year period, the Manufacturer will, at its option, (a) repair or replace such product free of charge, F.O.B. the factory of manufacture, or (b) refund to the original purchaser the original purchase price, in lieu of such repair or replacement. Labor costs associated with the replacement or repair of the product are not covered by the Manufacturer.

CONDITIONS AND LIMITATIONS

1. The product must be installed by and operated in accordance with the instructions published by the Manufacturer or Warranty will be void.
2. Warranty is void if all components of the system are not original equipment supplied by the Manufacturer.
3. This product must be purchased from and installed by an authorized dealer or certified representative thereof or the Warranty will be void.
4. Malfunctions or damage resulting from misuse, abuse, negligence, alteration, accident, or lack of proper maintenance shall not be considered defects under the Warranty.
5. This Warranty applies only to systems for the care of grain and feed. Other applications in industry or commerce are not covered by this Warranty.

* Painted parts are only warranted for one year against surface rust.

The Manufacturer shall not be liable for any consequential or special damage which any purchaser may suffer or claim to suffer as a result of any defect in the product. “Consequential” or special damages” as used herein include, but are not limited to, lost or damaged products or goods, costs of transportation, lost sales, lost orders, lost income, increased overhead, labor and incidental costs and operational inefficiencies.

THIS WARRANTY CONSTITUTES THE MANUFACTURER’S ENTIRE AND SOLE WARRANTY AND THIS MANUFACTURER EXPRESSLY DISCLAIMS ANY AND ALL OTHER WARRANTIES, INCLUDING, BUT NOT LIMITED TO, EXPRESS AND IMPLIED WARRANTIES AS TO MERCHANTABILITY, FITNESS FOR PARTICULAR PURPOSES SOLD AND DESCRIPTION OR QUALITY OF THE PRODUCT FURNISHED HEREUNDER.

BROCK dealers are not authorized to modify or extend the terms and conditions of this Warranty in any manner or to offer or grant any other warranties for BROCK® products in addition to those terms expressly stated above. An officer of CTB, Inc. must authorize any exceptions to this Warranty in writing. The Manufacturer reserves the right to change models and specifications at any time without notice or obligation to improve previous models.

Effective March 2016

BROCK GRAIN SYSTEMS
A Division of CTB Inc.
P.O. Box 2000 • Milford, Indiana 46542-2000 • U.S.A.
Phone (574) 658-4191 • Fax (574) 658-4133
e-mail: brock@brockgrain.com • Internet: <http://www.brockgrain.com>

© 2016 Brock Grain Systems. All rights reserved.

All product names in this Manual are trademarked or copyrighted by their respective owners. All rights reserved.

This Manual may not, in whole or in part, be copied, reproduced, or converted to digital format without prior written consent of Brock Grain Systems. Details herein are subject to change without notice. Printed in the United States.

Thank You

The employees of BROCK would like to thank you for your recent purchase. If a problem should arise, your BROCK dealer can supply the necessary information to help you.

Contents

Warranty	2
General	4
Remember! Think SAFETY First!	4
Support Information	4
Distributor and Installer Information	4
About This Manual	5
Identification of Parts and Hardware	5
SAFETY	6-12
Recognize SAFETY Information • Understand Signal Words	6
Follow SAFETY Instructions	6
Electrical SAFETY	7
DANGER, WARNING and CAUTION Decals	8
There are Suffocation Hazards in Flowing Grain and Feed!	9
SAFETY Decal Placement	10
Safety Hazards and Recommendations	10
Twelve Points That Could Save Your Life	11-12
Considerations that may result in a hazard, damage your bin and/or void your Warranty	12
Planning Before Your Bin Arrives	13
Choose The Bin Site • Check Delivery	13
Tools and Equipment Needed	13
Foundations	14-19
Standard Anchoring	14
Alternate Anchoring	15
6' [1 829] Foundations: Anchor Locations and Concrete Specifications	16
7' [2 134] Foundations: Anchor Location and Concrete Specifications	16
9' [2 743] Foundations: Anchor Location and Concrete Specifications	17
Square Foundations	18
Round Foundations	19
Body Sheet Assembly	20-22
Body Sheet Identification • Body Sheet Gauges	20
Caulking (Sealant) Is Critical!	20
Hardware Connections and Assembly Procedures	21
Overview • Bottom Ring	21
Second Ring • Additional Rings	22
Roof	23
Roof and Fillhole Collar • Roof Ladder Locations	23
Hopper Assembly	24-25
Hopper and Hopper Collar	24
Hopper Reinforcement Angle	25
Legs	26-28
Leg Attachment	26
9' [2 743] 60° Leg Attachment	26
Attach Leg Anchoring Assembly	27
Leg Anchor Weldment	27
X-Brace Identification	28
Brace Attachment	28
Collar Brace Attachment	28
Standing the Bin Upright	29
Standard Hopper Bin Leg Anchoring	30-31
Anchoring the Leg to Support Structure Beam	31
Bin Grounding	31
Hopper Bin Assembly Diagrams	32-39
6' [1 829] Diameter 60° Hopper Bin Specifications	32-33
7' [2 134] Diameter 67° Hopper Bin Specifications	34-35
9' [2 743] Diameter 45° Hopper Bin Specifications	36-37
9' [2 743] Diameter 60° Hopper Bin Specifications	38-39

General

Support Information

BROCK® products are designed for grains and/or free flowing materials. **Using this equipment for any other purpose or in a way not within the operating recommendations specified in this Manual will void the Warranty and may cause injury or death.** This Manual is designed to provide comprehensive planning and construction information for this BROCK® product. The Table of Contents provides a convenient overview of the information in this Manual.

Dealers: Please provide the Customer with the information to complete the easy reference below.

Dealer or Customer: Complete the following information about your BROCK® product.

Distributor and Installer Information

Please fill in the following information about your Product.
Keep this Manual in a clean, dry place for future reference.

Distributor's Name _____

Distributor's Address _____

Distributor's Phone _____ **Date of Purchase** _____

Installer's Name _____

Installer's Address _____

Installer's Phone _____ **Date of Installation** _____

System Specifications _____

Check Delivery

Your Grain Bin is made up of many parts and checked carefully at the time of shipment. However, use the packing slip and check your shipment on arrival to be sure it is complete.

IMPORTANT! *How to control "Wet Storage Stain" (RUST!) on galvanized Body Sheets: Do not permit moisture from weather, condensation, or other sources to remain between Body Sheets. If moisture is present, separate the Sheets IMMEDIATELY for good air circulation. Where possible, store all Bin components in a warm, dry place away from contaminants such as fertilizer, chemicals and road salt. If this is not done, white/red rust will appear.*

About This Manual

The intent of this Manual is to help you in two ways. One is to follow step-by-step in the order of assembly of your Hopper Bin. The other way is for easy reference if you have questions in a particular area.

Follow recommended precautions and safe operating practices of national and/or local codes at each installation site.

Major changes from the last printing are listed on the back cover.

Optional equipment contains necessary instructions for assembly or operation.

IMPORTANT! *Read ALL instructions and study all Figures in this Base Construction Manual and all Supplemental Manuals carefully before starting construction.*

IMPORTANT! *Pay particular attention to all SAFETY information on pages 7-15. Hard hats must be worn during construction.*



- **Measurements:** English measurements are listed first. The symbol " equals **inches** and ' equals **feet**. Metric measurements follow the English measurement in *italics* inside square brackets. The metric measurement is in **millimeters** unless otherwise specified. English/*metric* measurement example: 15' [4 572] 24' [7 315]
- **Orientation and direction:** “horizontal,” “vertical,” “bottom” and “top” refer to the Grain Bin as it is **standing**. “Left” and “right” refer to the Grain Bin as you are looking at it from the **outside**.
- This Planning symbol at left is used in areas where planning needs to take place **before** construction continues. When you see this Planning symbol, decisions must be made regarding your particular installation.

IMPORTANT! *No hardware substitutions are permitted unless noted.*

Diagrams are provided throughout this Manual to identify Parts and Hardware used in that application.

- Parts and basic components are identified in **Figures** and their accompanying Tables as “Items” with a black number in white circle.
- Hardware (and hardware **connections** between Parts) are identified with a white number in a **shaded** circle. See **Figure 1**. Hardware Item numbers are listed after the Parts in the **Figure** Table.
- Dimensions and lengths are noted with a white circle **on** an arrow or line, then identified with numeric values in the **Figure** Table.
- Specific holes, positions, or locations mentioned in the text are noted in the **Figure** with an **asterisk***.

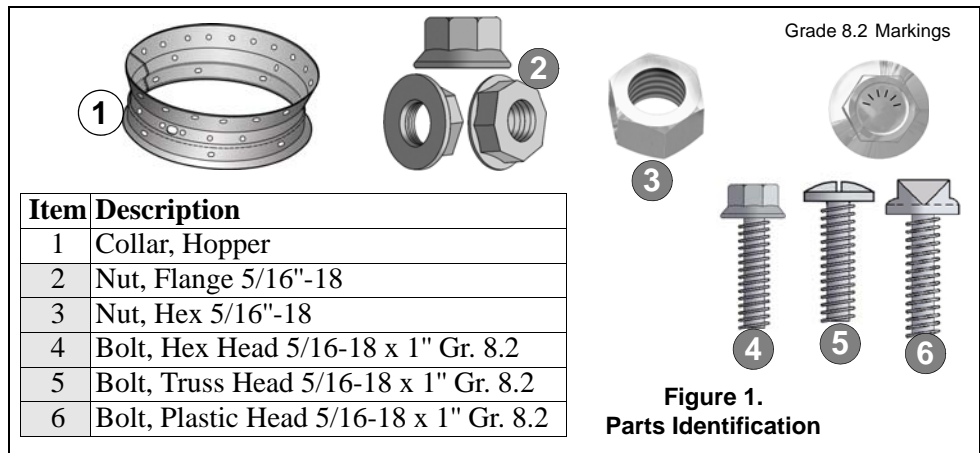

SAFETY**Remember! Think SAFETY First!**

This symbol is used throughout this Manual to identify particular stages where the bin Contractor and/or Operator need to take special note and precautions regarding the DANGER described in these Instructions. Please read all the SAFETY information and the Instructions completely prior to beginning the construction.

**Recognize SAFETY Information**

This is the Safety-Alert Symbol. When you see this symbol on your equipment or in this Manual, be alert to the potential for personal injury.

Signal words **DANGER**, **WARNING**, or **CAUTION**, are used with the Safety-Alert Symbol.

Understand Signal Words

DANGER indicates an imminently hazardous situation which, if not avoided, **WILL** result in death or serious injury.



WARNING indicates a potentially hazardous situation which, if not avoided, **COULD** result in death or serious injury.



CAUTION indicates a hazardous situation which, if not avoided, **MAY** result in minor or moderate injury.

Follow SAFETY Instructions

Carefully read all SAFETY messages in this Manual and on your equipment SAFETY signs. Follow recommended precautions and safe operating practices.

Keep SAFETY signs in good condition. Replace missing or damaged SAFETY signs.

For operation and use of your Hopper bin, read and understand the Owner's/Operator's Manual.

WARNING!

Failure to follow proper assembly and operational procedures may cause damage to equipment or personal injury.

CAUTION!

Bin installations shall meet the National Fire Protection Association Standard 61B for the prevention of fires and explosions in grain elevators and facilities handling bulk raw agricultural commodities.

SAFETY



Electrical SAFETY



Figure 2.
Electrical Warning

In selecting electrical control equipment to be used with any installation, the purchaser must use equipment conforming to the National Electrical Code, the National Electrical Safety Code and all other applicable local or national codes or regulations.

Important consideration should be given to some or all of the following devices and to others which may be appropriate:

1. **Overload protection devices** such as shear pins, torque limiters, zero speed switches, etc., to shut off and lock out power whenever operation of equipment is stopped as a result of excessive material, foreign objects, excessively large lumps, etc.
2. **Safety shut-off switch** with power lockout provisions at auger drive.
3. **Emergency stop switches** readily accessible wherever required.
4. **Electrical interlocking** to shut down the feeding auger whenever a receiving auger stops.
5. **Signal devices to warn personnel** of possible startup of auger, especially if started from another location.
6. Special enclosures for motors and controls for hazardous atmospheric conditions.

DANGER!



It is a matter of extreme SAFETY importance that your bins are NOT placed where feed trucks, augers or other equipment may accidentally come in contact with electric power lines, control boxes or other electrical hazards which may result in serious injury or death!

Contact your power company before construction for a review of proper line clearance. This could save you the expense of moving facilities later.

SAFETY



DANGER, WARNING and CAUTION Decals

SAFETY information has been provided by the Manufacturer to help insure the safe and proper use of this product. This SAFETY information has been placed on components throughout the structure to provide proper access to the user.

The Decals in **Figures 3, 4, 5, 6, and 7** are located on equipment as shown in the Manual drawings on Page 11. If the SAFETY Decals are not properly placed or if they are in any way damaged or altered, call the Manufacturer for immediate replacement.

IMPORTANT!

Check all equipment for DANGER, WARNING and CAUTION Decals and their proper placement, BEFORE equipment is operated. NEVER use equipment if Decals are missing, improperly placed, damaged, or altered.



Figure 3.
DANGER Suffocation Decal 13-37448



Figure 4.
DANGER/Auger Decal 13-37447



Figure 5.
DANGER/Auger Decal 2527-9



Figure 6.
CAUTION/Guards Decal 13-26115

SAFETY 



Figure 7.
DANGER/Auger Decal 13-25805

DANGER!  **There are Suffocation Hazards in Flowing Grain and Feed!**
Never enter a bin of flowing feed, grain, or other material. Failure to follow these instructions will result in death or serious injury

From the time the auger starts, you have 2-3 seconds to react.

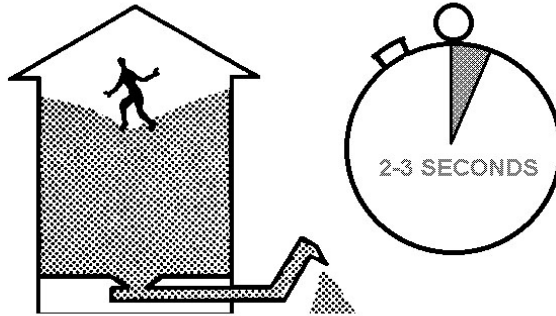

In 4-5 seconds, you are trapped.

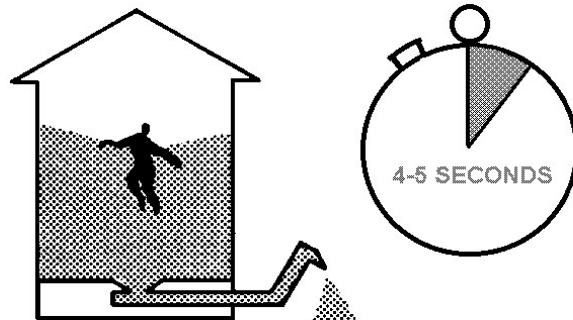

After 22 seconds, you are completely covered.

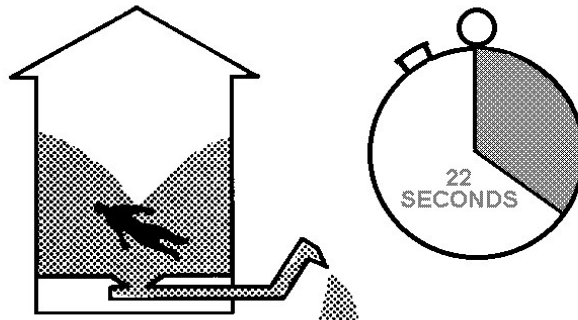

Figure 8.
Suffocation Hazards in Flowing Grain

SAFETY 



DANGER Decal 13-37448 (above) and DANGER Decal 13-37448SP (right)
 These Decals are found on either side of the SPRING-LOCK® Lid on Hopper Bins with Closed Eave Roofs. 13-37448 should read exactly as the Decal on Page 8, **Figure 3**. Located in the Lid.

IMPORTANT!

*Check all equipment for **WARNING, DANGER and CAUTION** Decals and their proper placement, **BEFORE** equipment is operated. **NEVER** use equipment if Decals are missing, improperly placed, damaged or altered. Contact your **BROCK Dealer** for replacements.*



WARNING/Shur-Lock Lid Decal 13-37447
 Should read exactly as Decal on Page 8, **Figure 4**. Located on the optional SHUR-LOCK Lid.



CAUTION/Guards Decal 13-26115
 Should read exactly as Decal on Page 8, **Figure 6**. Located on the Belt Guard and Discharge Head.



CAUTION Decal Falling Debris 13-33761
 Located on the outside of the ACCESS-PLUS® Door.



DANGER/Auger Decal 2527-9
 Should read exactly as Decal on Page 8, **Figure 5**. Located on the Boot Cleanout Cover and on the Discharge Head (FLEX-AUGER® models) and on the ACCESS-PLUS® Door.



DANGER/Auger Decal 2527-9
 Should read exactly as Decal on Page 8, **Figure 5**. Located on the Discharge Head (FLEX-AUGER® models)



DANGER/Auger Decal 13-25805
 Should read exactly as Decal on Page 9, **Figure 7**. Located on the Boot Cleanout Cover and on the Discharge Head (solid Auger models).

Figure 9.
SAFETY Decal Placement

SAFETY

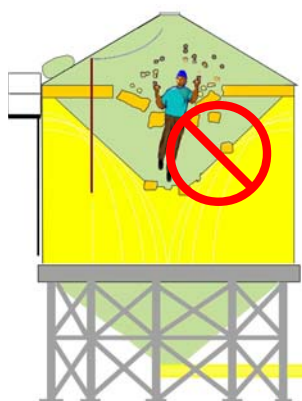

Figure 10a.
Grain Crusting
and Bridging

Act responsibly NOW to reduce the risk of Emergency.

Be sure to advise your children, your co-workers, and your neighbors about this SAFETY information.

Safety Hazards and Recommendations

Twelve Points That Could Save Your Life

The information below and on the facing page is often reprinted in some form by the media when an accident occurs. But such reprints are not deterring unsafe bin entries that are leading to entrapments. Fatalities are still occurring. This Manual attempts to bridge the apparent disconnect between this straightforward list and the graphic details. Remember to always follow national and locally developed guidelines (OSHA in the U.S.) and applicable sections—at least those listed—for safe grain system operation.

1. **Never enter a bin of flowing grain**—when loading or unloading equipment is running, whether or not grain is flowing or stopped; you can be engulfed if and when the flow resumes. See **Figure 10**, page 13. Moving grain creates a suction that can pull a worker in within seconds. Never enter a bin that has automatic unloading equipment **without locking out the control panel/circuit and any other power that may start the equipment**.
2. Always be cautious when you are working with grain that is **not in good condition**.
3. Never enter a bin that you do not know the nature of previous grain removal, especially if there is any vertical or horizontal **crusting** or **bridging** evident. See **Figure 10a**, left. There may be blocked flow, toxic molds, empty cavities, cave-offs, or any combination of the above—which can lead to entrapment/engulfment and suffocation.
4. Prohibit entry into and **do not walk on any surface crust** where there is horizontal bridging. Prohibit entry into and **do not walk near any surface crust** where there is vertical bridging.
5. If you are properly trained and qualified to do so and must enter a bin with evident danger, follow all national, state and local safety codes for bin entry. Complete and verify that all **safety steps required for a Bin Entry Permit** have been followed.
6. Be sure that **rescue equipment**, such as winch systems, are provided and working.
7. **Test the air** for the presence of sufficient oxygen and/or combustible and toxic gases. Provide and continue ventilation until any unsafe atmospheric conditions are eliminated.
8. The bin entrant must be provided with and must be fastened to a **safety harness-lifeline** or boatswain's chair secured and monitored by two attendants outside (Point 10). The lifeline should be a proper length to prevent the entrant from sinking into grain further than waist-deep.
9. Before entering a grain bin, **de-energize and turn off, LOCK OUT and TAGOUT** all mechanical, electrical, hydraulic and pneumatic equipment that presents a danger, especially unloading equipment, which will cause a worker to be pulled into the grain in seconds.
10. Provide *per entrant* a minimum of two (2) **properly equipped attendants** stationed outside the bin, whose only task is to continuously track and communicate with the entrant in the bin, to provide assistance if necessary, and to be capable of lifting the entrant out without entering the bin themselves. **Never depend** on one (1) attendant only, either on the roof, ground, or any other remote point to whom you would shout instructions *to start or stop equipment*. (Equipment noise or other sounds can block out commands or cries for help.) A single attendant cannot go for help **and** maintain preliminary aid outside, and may fall or over-exert in the haste of running to the control point.
11. The bin entrant must be provided with a proper mask or an **adequate dust-filtering respirator** when working in and around grain handling areas. High amounts of dust and molds could be present and are extremely dangerous. Never work in obviously dusty-moldy grain, or where the presence of CO₂ is suspected, without a respirator capable of filtering fine dust. Be aware that your tolerance to a given material may be limited, and that you should not deliberately expose yourself to grain dust on the premise that you will not be affected at any time.
12. If another person becomes submerged in grain, assume he is alive. Begin rescue operations immediately by turning OFF the unloading equipment if not already locked out, and turning ON the fan to move air into the bin, but: never attempt a rescue by going into the bin yourself. Call 911. Always have a rescue plan and be prepared for grain facility emergencies by working early with your local emergency team to get training and equipment to do the job safely.

SAFETY

Employers must act responsibly now to reduce the risk of emergency!

Before it is too late: Talk to your children, co-workers, and your neighbors about the SAFETY information in this Manual. Many lives depend on it.

Your attention to SAFETY will impact:

- You and your family
- Your employees
- Your neighbors and community
- Your subcontractors
- Your customers and future customers
- The grain bin industry as a whole

Prohibit “walking down” grain, or similar practices, to make it flow.

- Label grain bins to warn of entrapment hazards.
- Lock entrances to grain handling areas to keep bystanders and children out.

Considerations that may result in a hazard, damage your Bin and/or void your Warranty

BROCK® bins are offered in several models for specific uses. In order to maintain your bin and its Warranty, the appropriate type bin must be used. Refer also to Page 6 of this Manual. Consult BROCK Grain Systems or your BROCK Dealer.

Read and understand this Construction Manual, your *BROCK® Owner/Operator's Manual for Feed and Wet-Holding Hopper Bins* (MHB1260) and all SAFETY Decals.

Damage to a bin can occur due to improper **construction** of the bin. Therefore:

1. Use **all hardware specified** in the instructions and make no substitutions.
2. Refer to pages 16-20 in this Manual for proper Foundation specifications.
Cracks in the foundation are a danger signal. It is suggested that if cracks are present they be monitored for any changes, and remedial action taken.
3. Bin foundations must be **level**.

Cables to support conveying equipment such as bucket elevators or conveyor legs must not be attached to the bin roof or sidewalls. To do so will cause damage to the bin. Refer to your Roof Manual for construction of proper supports for such equipment.

CAUTION!

Additional loads on bin sidewalls, roofs and hoppers can be created by improper drying methods. Failure to follow procedures outlined in the Owner/Operator's Manual may result in bin damage.

Bin damage can also occur due to improper **ventilation** or **loading and unloading** of the bin:

1. When the bin is filled off-center.
2. When unloading is done from off-center. Uneven wall pressures may occur, allowing the wall to flatten directly nearest the unloading point, and damage can be seen above and several feet to either side of this area. Severe sheet seam damage can occur, causing significant or complete bin damage. Internal pressures change when only a few bushels of grain or feed have been removed. Damage can be caused by incorrectly unloading even small amounts of material.

Planning Before Your Bin Arrives



Choose The Bin Site

Select the site of your bin with care. Planning for future expansion is of prime consideration.

Check Delivery

Your bin is made up of many parts and checked carefully at the time of shipment, however, use the packing slip and check your shipment on arrival to be sure it is complete.

IMPORTANT!

How to control “Wet Storage Stain” (RUST!) on galvanized Body Sheets: Do not permit moisture from weather, condensation, or other sources to remain between Body Sheets. If moisture is present, separate the Sheets IMMEDIATELY for good air circulation. Where possible, store all Bin components in a warm, dry place away from contaminants such as fertilizer, chemicals and road salt. If this is not done, white/red rust will appear.

The paper cover on the BROCK® Decal helps prevent damage to the Decal during Bin construction. However, it may be difficult to remove if left in direct sunlight for several hours.

Tools and Equipment Needed

- 7/16" - 1" Box End Wrenches
- Adjustable Wrenches up to 1-1/2" [38] for adjustable expanders
- 12" [305] Long Drift Punches
- Hammer
- Screwdriver
- Speed Wrench and Sockets
- Impact Wrench and Sockets
- Lifting Jacks
- Lifting Brackets
- Protective gloves and eyewear
- Nail aprons to hold a supply of bolts and nuts during assembly

IMPORTANT!

The number of lifting jacks and brackets required is determined by factors such as bin size, soil compaction, wind velocity, design of jacks, etc.

A 3/8" Grade 8.2 Bin Seal Bolt has an approximate safe load of 2,650 pounds [1 202 kg].

A 5/16" Grade 8.2 Bin Seal Bolt has an approximate safe load of 1840 pounds [835 kg].

Keep this in mind when determining the number of bolts to use to lift the bin during assembly.

Tighten 5/16" Nuts to 15-20 ft-lb [20-27 N-m] of torque.

Tighten 3/8" Nuts to 25-30 ft-lb [34-41 N-m] of torque.

Foundations



The Foundation shall be placed on undisturbed soil of bearing capacity of at least 3000 psf [14 647 kg/m²] or special modification of foundation must be considered. If questions arise, contact a qualified soil engineer.

The Foundation shall be appropriately designed for local soil and frost depth conditions. Sizes given are adequate for resisting 1.5 times the overturning force of a 90 mph [145 km/h] wind and seismic zone 1.

The Foundation should be smooth and level to within 1/4" [6.4].

Concrete in footings shall have a minimum compressive strength, $f_c' = 3000$ psi (pounds per square inch) [20 684 kPa] at 28 days.

Concrete reinforcing steel shall have a minimum yield strength of 33,000 psi [227 527 kPa].

Concrete should be cured seven days before building bin and 28 days before filling the bin.

Standard Anchoring

A 5/8" x 8" x 2" Anchor Rod (Part No. 39-20075) is available from Brock Grain Systems. Anchors must be embedded 6 1/2" [165].

The following bins use 5/8 x 12" Heavy Hex Head Bolt, embedded 10" [254], with Heavy Nut and Octagon Washer. These are included in the parts kit.

- 6' [1 829] 7-8 ring
- 7' [2 134] 6-8 ring
- 9' [2 743] 45° 11 ring
- 9' [2 743] 60° 7-10 ring

CAUTION!



Measure between opposite and adjacent Anchors to be sure they are an equal distance apart before securing. Failure to do so may cause damage to the Bin.

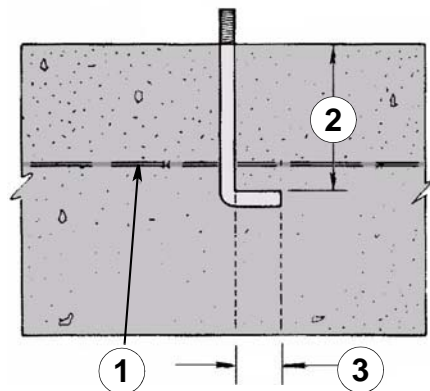

Item	Description
1	6 x 6 - W1.4 x W1.4 WWF [152 x 152 - MW9 x MW9 WWF] (WWF=Welded Wire Fabric) must be placed at mid-depth of the concrete slab or above
2	6 1/2" [165]
3	2" [50.8]

Figure 10.
Anchor Detail

Alternate Anchoring

IMPORTANT!

The alternate anchoring presented on this page is not for 7' [2 134] 67° 6-ring bins, nor for 9' [2 743] 60° 7-ring bins.

Install Anchor Rods before setting bin to insure proper location.

- 1) A 5/8 x 9" Heavy Hex Gr. 2 Bolt embedded to a depth of 7" [178].

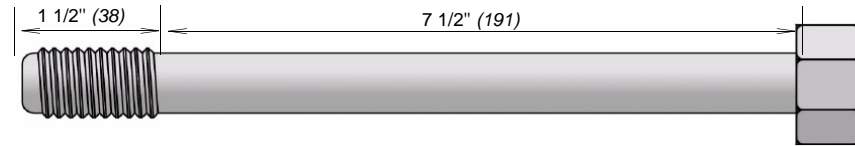

Figure 11.
5/8 x 9" Heavy Hex Gr. 2 Bolt

- 2) HILTI® Kwik-Bolt 3 Expansion Anchor, 3/4 x 7" or equivalent. Each Anchor must have a minimum embedment of 5" [127].



Figure 12.
Hilti® Kwik Bolt 3 Carbon Steel Expansion Anchor

- 3) HILTI® HAS-E Anchor Rod, 5/8" x 8" or equivalent. Each Anchor must have a minimum embedment of 6" [152].



Figure 13.
Hilti® HAS-E Anchor Rod and HVU Adhesive

CAUTION!



Lay out locations and install anchors before setting the bin to insure proper location. Failure to do so may cause damage to the bin.

Do NOT use Legs as a template to drill, because the bin may not be round.

6' [1 829] Foundations: Anchor Location and Concrete Specifications

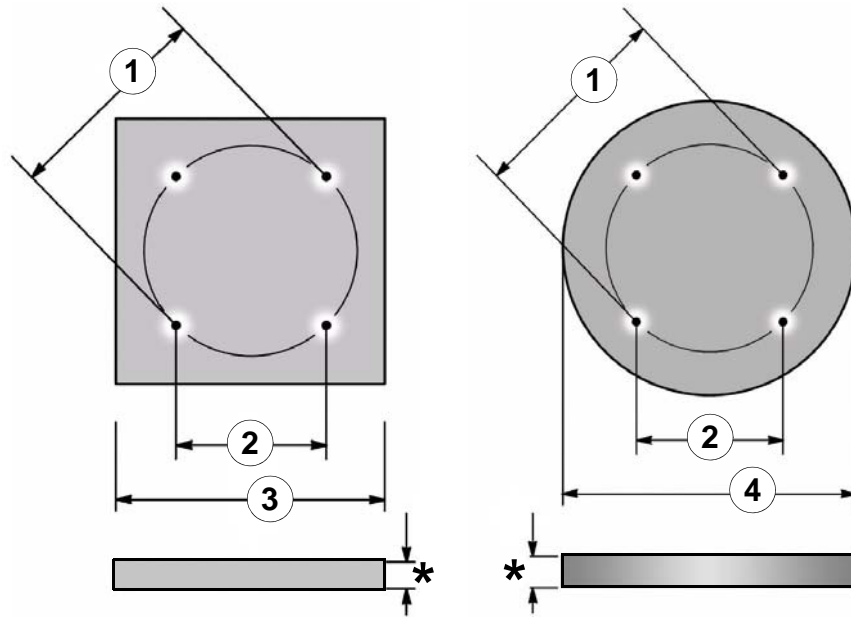

SQUARE FOUNDATION

ROUND FOUNDATION

Item	Description
1	76 1/16" [1 932]
2	53 25/32" [1 366]
3	8' [2 438]
4	9' [2 743]

Anchor locations are the same for each diameter foundation, round or square.

*See Thickness Charts on pages 18 and 19.

Figure 14.
6' [1 829] Diameter Bins

7' [2 134] Foundations: Anchor Location and Concrete Specifications

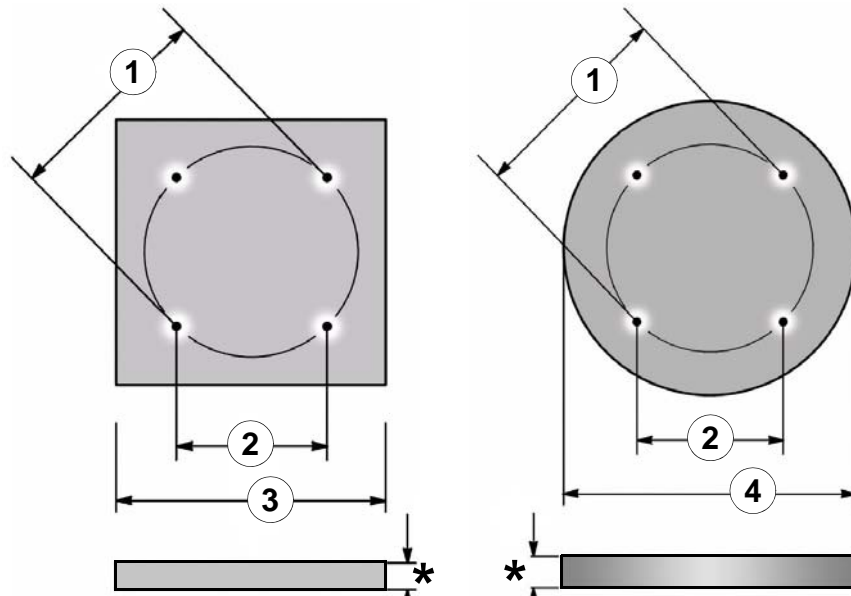

SQUARE FOUNDATION

ROUND FOUNDATION

Item	Description
1	88" [2 235]
2	62 1/4" [1 581]
3	9' [2 743]
4	10' [3 048]

Anchor locations are the same for each diameter foundation, round or square.

*See Thickness Charts on pages 18 and 19.

Figure 15.
7' [2 134] Diameter Bins

9' [2 743] Foundations: Anchor Location and Concrete Specifications

Anchor locations are the same for each diameter foundation, round or square.

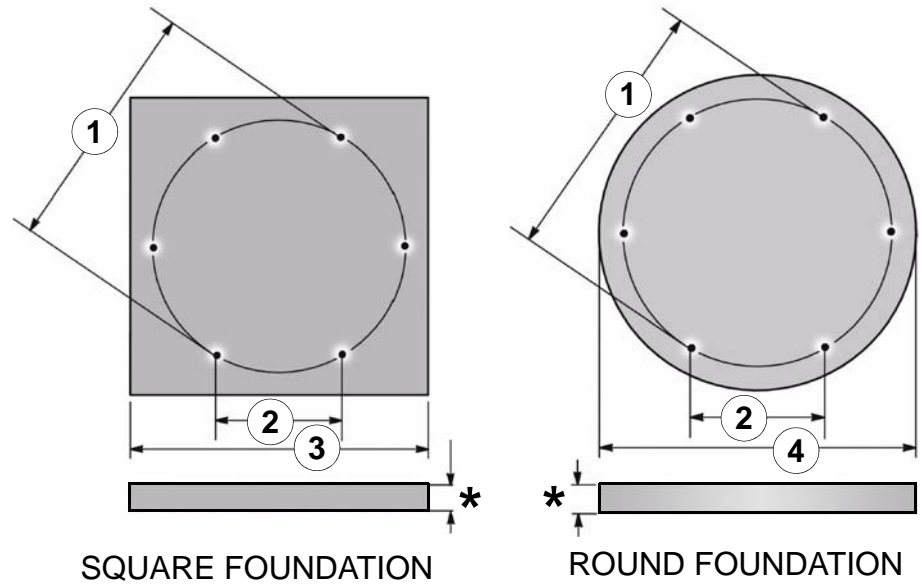

Figure 16A.
9' [2 743] Diameter Bins (6 Legs)

Item	Description
1	111 7/8" [2 842] diameter
2	55 15/16" [1 421] 6-Leg Chord (45° 1-7 Rings; 60° 1-10 Rings)
3	11' [3 353]
4	12' [3 658]
5	38 1/4" [972] 9-Leg Chord (45° 8-11 Rings)

*See Thickness Charts on pages 18 and 19.

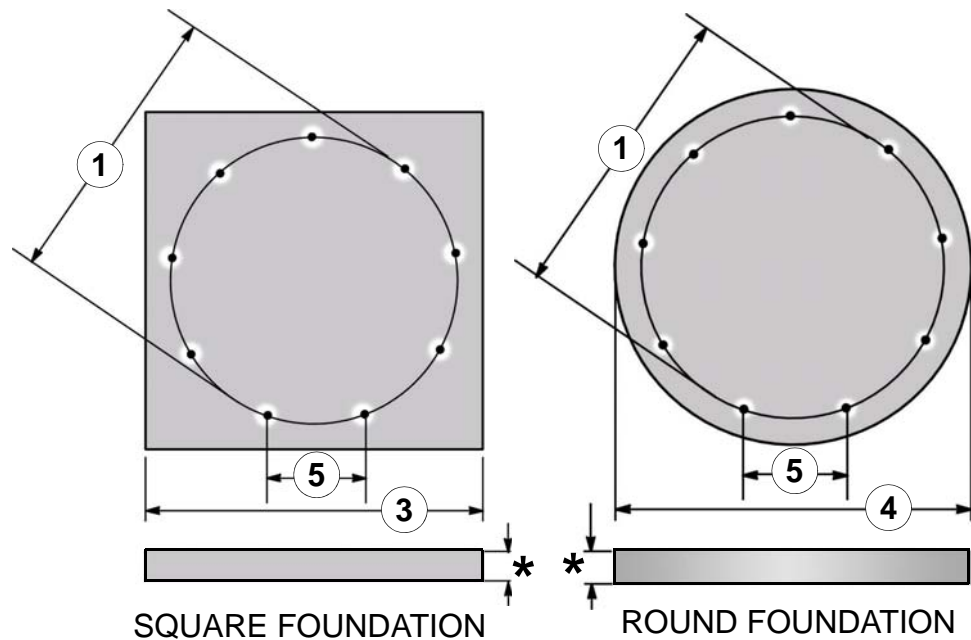

Figure 16B.
9' [2 743] Diameter Bins (9 Legs)

Square Foundations

Footer Concrete Specs (ENGLISH)						
Model	6' dia.		7' dia.		9' dia.	
Foundation Size	8' x 8'		9' x 9'		11' x 11'	
Rings	Thickness (inches)	Volume (cu. yds.)	Thickness (inches)	Volume (cu. yds.)	Thickness (inches)	Volume (cu. yds.)
1	8"	1.6	8"	2.0	8"	3.0
2	8"	1.6	9"	2.3	9"	3.4
3	8"	1.6	10"	2.5	9"	3.4
4	9"	1.8	11"	2.8	10"	3.7
5	10"	2.0	11"	2.8	10"	3.7
6	13"	2.6	13"	3.3	11"	4.1
7	15"	3.0	16"	4.0	12"	4.5
8	18"	3.6	18"	4.5	14"	5.2
9					16"	6.0
10					18"	6.7
11					17"	6.3

Footer Concrete Specs (METRIC)						
Model	1 829 dia.		2 134 dia.		2 743 dia.	
Foundation Size	2 438 x 2 438		2 743 x 2 743		3 353 x 3 353	
Rings	Thickness [mm]	Volume [cu. m.]	Thickness [mm]	Volume [cu. m.]	Thickness [mm]	Volume [cu. m.]
1	203	1.2	203	1.5	203	2.3
2	203	1.2	229	1.8	229	2.6
3	203	1.2	254	1.9	229	2.6
4	229	1.4	279	2.1	254	2.8
5	254	1.5	279	2.1	254	2.8
6	330	2.0	330	2.5	279	3.1
7	381	2.3	406	3.1	305	3.4
8	457	2.8	457	3.4	356	4.0
9					406	4.6
10					457	5.1
11					432	4.8

Round Foundations

Footer Concrete Specs (ENGLISH)						
Model	6' Dia.		7' Dia.		9' Dia.	
Foundation Size	9' Dia.		10' Dia.		12' Dia.	
Rings	Thickness (inches)	Volume (cu. yds.)	Thickness (inches)	Volume (cu. yds.)	Thickness (inches)	Volume (cu. yds.)
1	8"	1.6	8"	1.9	8"	2.8
2	8"	1.6	9"	2.2	9"	3.1
3	8"	1.6	10"	2.4	10"	3.5
4	9"	1.8	11"	2.7	10"	3.5
5	10"	2.0	12"	2.9	11"	3.8
6	12"	2.4	13"	3.2	12"	4.2
7	14"	2.7	15"	3.6	12"	4.2
8	16"	3.1	17"	4.1	13"	4.5
9					15"	5.2
10					17"	5.9
11					17"	5.9

Footer Concrete Specs (METRIC)						
Model	1 829 dia.		2 134 dia.		2 743 dia.	
Foundation Size	2 438 x 2 438		2 743 x 2 743		3 353 x 3 353	
Rings	Thickness [mm]	Volume [cu. m.]	Thickness [mm]	Volume [cu. m.]	Thickness [mm]	Volume [cu. m.]
1	203	1.2	203	1.5	203	2.1
2	203	1.2	229	1.7	229	2.4
3	203	1.2	254	1.8	254	2.7
4	229	1.4	279	2.1	254	2.7
5	254	1.5	305	2.2	279	2.9
6	305	1.8	330	2.4	305	3.2
7	356	2.1	381	2.8	305	3.2
8	406	2.4	432	3.1	330	3.4
9					381	4.0
10					432	4.5
11					432	4.5

Body Sheet Assembly

Body Sheet Identification

On the corner of each Body Sheet is a colored Sticker with the Part Number, gauge and diameter printed on it. This is helpful in locating each Sheet on the Specifications and Parts Lists.

Body Sheets are also identified with paint on an edge near the end. The first color nearest the end will indicate gauge and corresponds with the gauge and color chart below. Black paint next will indicate a Sheet with a sign.

Body Sheet Gauges

Gauge	Thickness		Color
	inches	mm	
20	.035	[0.88]	white
19	.040	[1.02]	brown
18	.046	[1.18]	pink
17	.053	[1.34]	yellow
16	.058	[1.47]	orange
15	.065	[1.66]	light blue
14	.072	[1.82]	dark green
13	.088	[2.25]	gray
12	.102	[2.59]	dark blue
11	.118	[2.99]	light green
10	.136	[3.45]	black

Caulking (Sealant) Is Critical!

Wipe the Body Sheets clean where the caulking is to be applied. All Collar, Body, Hopper and Roof seams are caulked with a bead of caulking on **each side** of the line of holes. Be sure to follow caulking instructions carefully. Take notice of these **critical caulking points**:

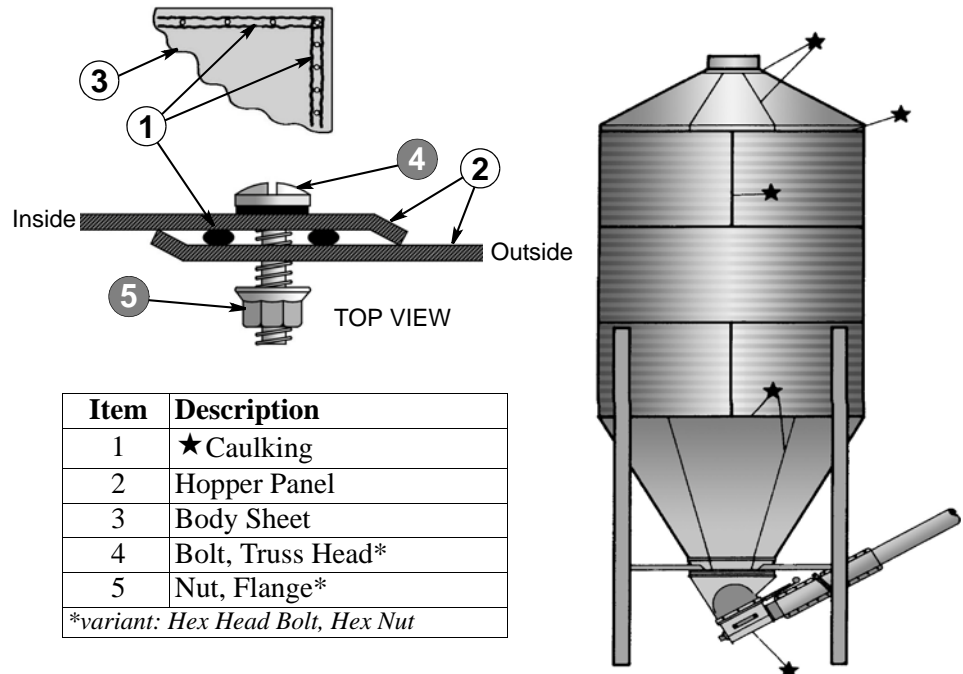

Figure 9. Critical Caulking Points

Hardware Connections and Assembly Procedures

All Hopper seams and the Hopper Collar use 5/16 x 3/4" Truss Head Bin Seal Gr. 8.2 Bolts and Flange Nuts with the heads **inside** the bin.

Body Sheet and Roof seams use 5/16 x 1" Grade 8.2 Hex Head Bin Seal Bolts and Hex Nuts, or the optional Plastic Head Bolts, with the heads **outside** the bin.

Leg-to-Body Bolts are 5/16 x 1" Grade 8.2 Hex Head Bin Seal Bolts and Hex Nuts, with the heads **inside** the Bin.

Overview

All Body Rings must be assembled with the vertical seams **staggered**.

6' [1 829] diameter bins use 2 Body Sheets per ring.

7' [2 134] diameter bins use 2 Body Sheets per ring.

9' [2 743] diameter bins use 3 Body Sheets per ring.

The Leg holes must be in **alignment** in the bottom two Rings (unless the bin is a one-ring bin).

Bin Seal Bolts are always tightened from the **nut** side to prevent damage to the seals. A drift punch should be used to align holes. 5/16 x 1" Grade 8.2 Hex Head Bin Seal Bolts are used on all vertical and horizontal body sheet seams with bolt heads on the **outside**. Note exception where Legs are attached. Bolt the Body Sheets end-to-end, overlapping the same direction throughout the bin. Only finger-tighten the Bolts until the next ring has been added.

Bottom Ring

Start the heaviest ring with Leg holes. Put the 3 1/8 [79.4] hole spacing at the bottom. Stand the Body Sheets on edge. Wipe clean the areas where the Caulking is to be applied.

Apply the Caulking as close to the line of Bolt holes as possible, using two beads, one on each side of the hole line. See **Figure 17**.

For a one-ring bin, tighten bolts at this time and proceed to Hopper and Collar assembly.

Refer to Assembly Diagram sheets on pages 32-39 for the particular diameter bin as assembly continues.

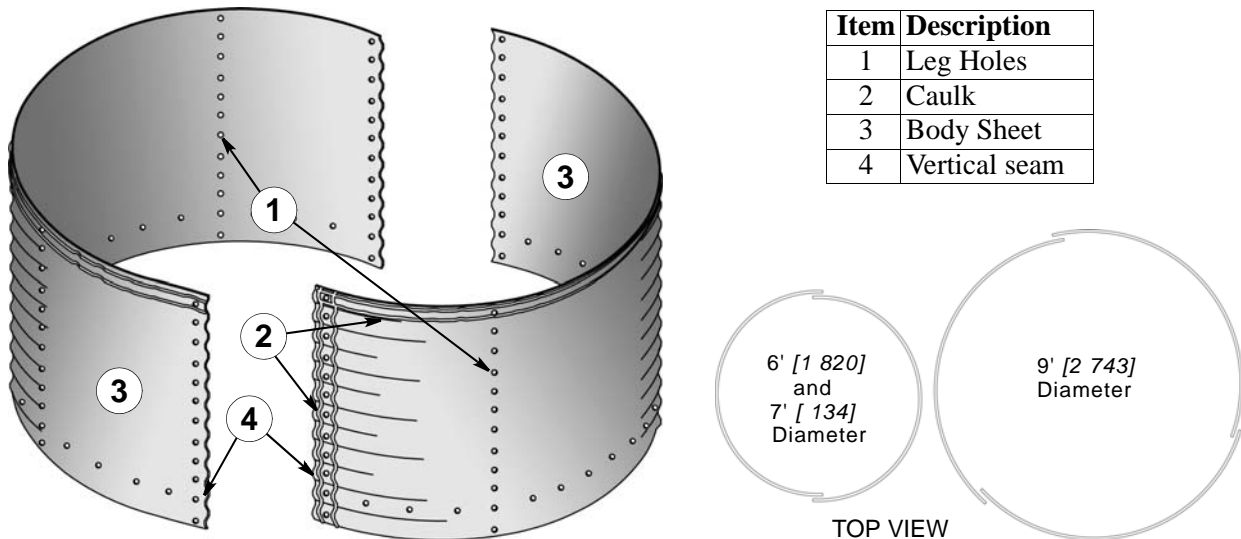

Figure 17.
Overlapping Body Sheets - Bottom Ring

IMPORTANT! On the 7' [2 134] bin, Leg Holes are not in the middle of the Body Sheets. To insure 65 5/8" [1 167] between Leg Holes, take extra care when bolting together vertical seams. Do NOT turn the Body Sheet upside down. Make sure the HYRDO-SHIELD® meets along the bottom edges.

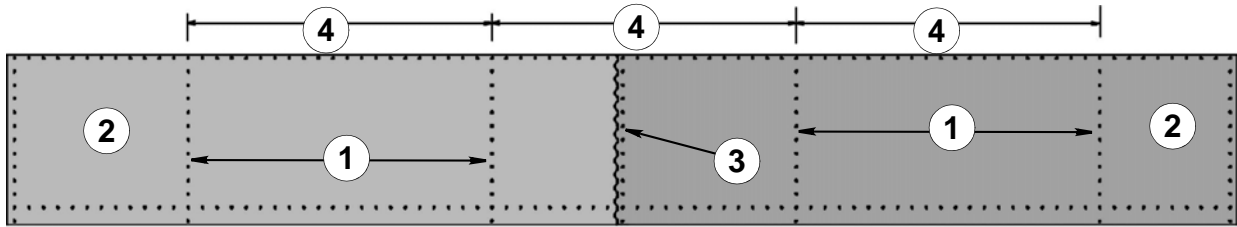

Figure 18.
Bottom Ring - 7' Hopper Bin

Item	Description
1	Leg Holes
2	Body Sheet
3	Vertical seam
4	65 5/8" [1 167]

Second Ring

Assemble the second ring on top and outside of the first (bottom) ring, caulking and bolting as before. See Figure 19.

Be sure to align the vertical seam in the **center** of the Bottom Sheet.

IMPORTANT! Leg holes must be in alignment for bins having two-ring Legs. See Figure 20 below.

Tighten Bolts in the horizontal seams from the **center** of the sheet **out** to the ends.

The bottom holes in the vertical seams of the second ring may have to be enlarged slightly to insert bolts. **Do not tighten at this time.**

Align the bottom hole in the vertical seams of the **bottom** ring and tighten Bolts.

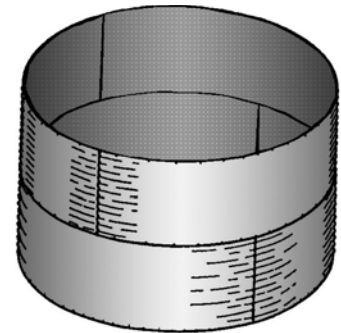
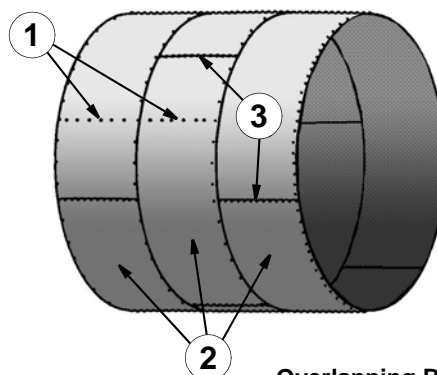

Figure 19.
Overlapping Body Sheets - Second Ring Up

Additional Rings

Now lay the assembled rings over so they can be rolled back and forth. Using the same wiping, caulking, bolting and tightening pattern, add the remaining rings. All Bolts should be tightened at this point. See Figure 20.

The top ring of Sheets is added last.



Item	Description
1	Leg Holes
2	Body Sheet
3	Vertical seam

Figure 20.
Overlapping Body Sheets - Additional Rings

Roof



IMPORTANT!

Roof and Fillhole Collar

Refer to Lid Instructions packaged with the Lid. Determine the location of the first Roof Panel. Refer to the Roof Ladder Instructions packaged with the Ladder.

The Roof must be started correctly for the Shur-Lock® Lid Opener to work properly. Refer to BROCK Manual MHB1183, "Shur-Lock Lid Operator Installation Instructions."

IMPORTANT!

If the bin is to use an air fill system, plan for that as you build the Hopper Bin Roof.

The Roof Ladder is centered over a Roof Panel but will not be centered between Legs. Be sure the location of the Roof Ladder will not put the Side Ladder in the way of other equipment. See Figure 22.

The Fillhole Lid should open about 90° from the Roof Ladder. The Lid Opener must be centered over a Roof Panel and centered over the Leg where the lid opener handle attaches.

Roof Reinforcement Angles bolt under the seams on either side of the Roof Ladder on 9' [2 743] Bins.

Caulk on both sides of the holes. Wipe, caulk and install all Roof Panels and the Fillhole Collar.

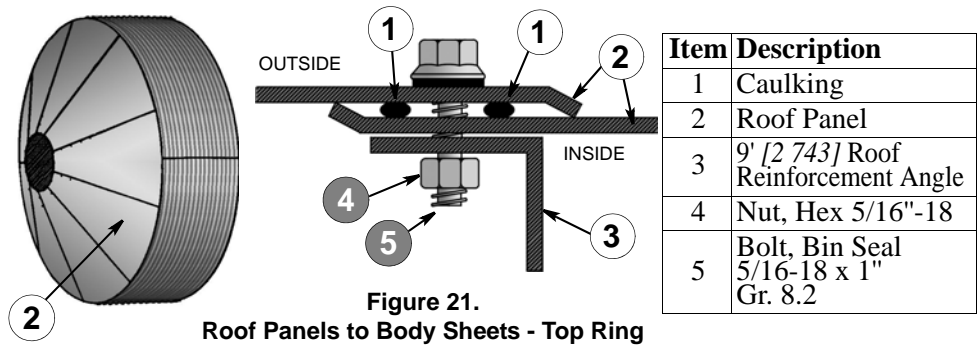
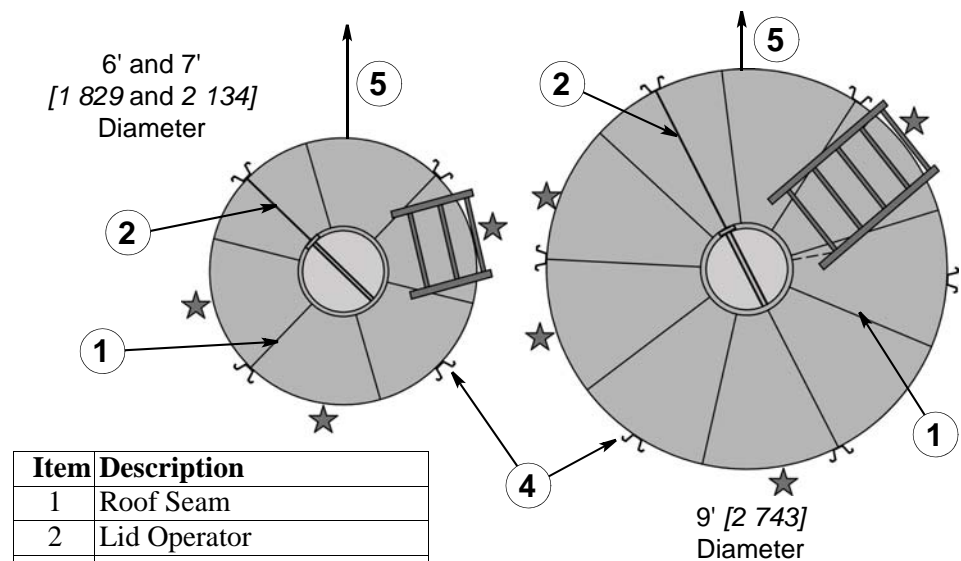

Figure 21.
Roof Panels to Body Sheets - Top Ring

Roof Ladder Locations

IMPORTANT!

Refer to *BROCK® Hopper Bin Ladder Instructions* MHB1370 packaged in Ladder Bracket Kits.



Item	Description
1	Roof Seam
2	Lid Operator
4	Leg
★	Possible Roof Ladder location
5	Auger to bldg.

Figure 22.
Possible Roof Ladder Locations

Hopper Assembly

Hopper and Hopper Collar

IMPORTANT!



The Hopper Panels should not be started until all Roof Panels are installed.

Determine which way the BROCK® Decal will face in relation to the Auger.

Wipe the **inside** of the bottom ring where the Hopper attaches (second corrugation up from bottom) and caulk along both sides of the holes.

Wipe and caulk the Hopper and Collar seams on both sides of the holes. See **Figure 23**.

Start the first Hopper Panel seam exactly midway between the set of Legs where the Auger will exit. On the 7' [2 134] dia. bin this will be one hole either way from the exact center.

Overlap vertical Hopper seams so the left formed edge is on top and traps the Caulking. Assemble all but one of the Hopper Panels.

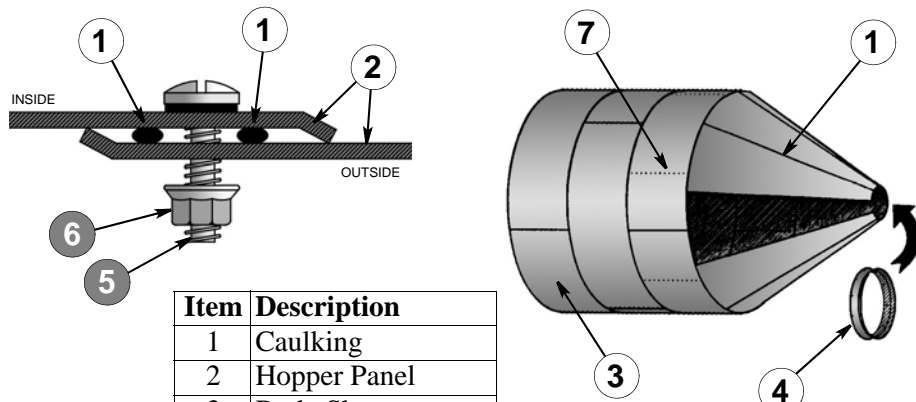

Item	Description
1	Caulking
2	Hopper Panel
3	Body Sheet
4	Hopper Collar
5	Bolt, Truss Head
6	Nut, Flange
7	Leg Holes

Figure 23.
Hopper Collar



Install the Hopper Collar so the input Access Hole is located **away** from the Auger and as near midway between a set of Legs as possible. If this hole is not used for accessory equipment, install the Hole Cover Plate * (Item 3-19040) over the hole with Truss Head Bolts and Flange Nuts. See **Figure 24**. Apply Caulk.

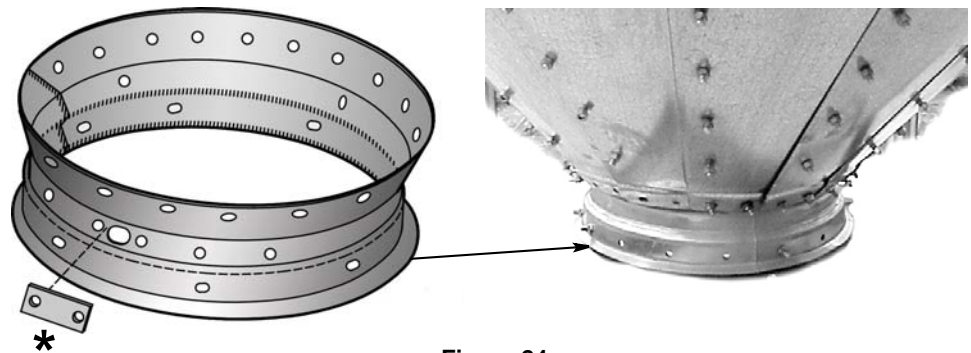

Figure 24.
Hopper Collar Access Hole and Hole Cover Plate

Install the last Hopper Panel and tighten all Bolts.

Hopper Reinforcement Angle

A full-length Hopper Reinforcement Angle is furnished for:

- 7' [2 134] 67° 5 through 8-ring bins (3-16507)
- 9' [2 743] 60° 3 through 10-ring bins (3-22597).

No bolt is used in the top hole of the 9' [2 743] Hopper Reinforcement Angle and bottom end stops above the Hopper Collar connection.

Angles should be ordered for **any** bin in which difficult flowing materials such as soybean meal, etc., will be stored.

IMPORTANT! *Cut Hopper Reinforcement Angles as necessary at the bottom end for 25" [635] Hopper openings.*

The Angle must be tight against **outside** of the Hopper Panel. Do **not** use double Nuts.

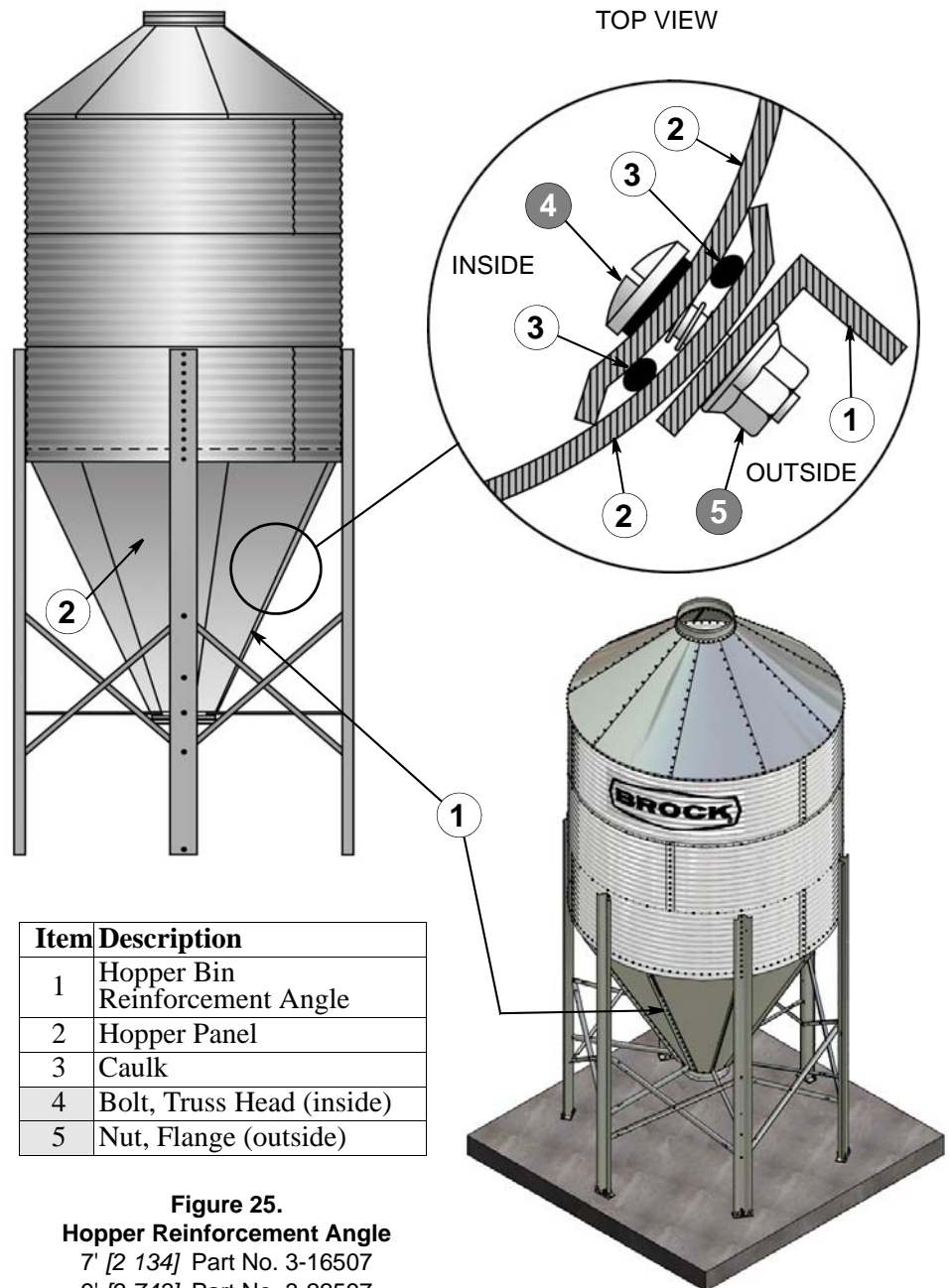

Item	Description
1	Hopper Bin Reinforcement Angle
2	Hopper Panel
3	Caulk
4	Bolt, Truss Head (inside)
5	Nut, Flange (outside)

Figure 25.
Hopper Reinforcement Angle
 7' [2 134] Part No. 3-16507
 9' [2 743] Part No. 3-22597

Legs

Leg Attachment

For 9' [2 743] 60° Hopper Bins, skip this section and proceed to the second section on this page.

Bolt the Legs to the Bin with the Bolt heads **inside**. **Do not tighten** at this time.

When more than 30" [762] clearance under the Collar is required, contact Brock Engineering for Leg extension and bracing requirements.

Follow the diagrams in **Figures 26** and **27** for the Leg attachments.

Item	Description
1	Body Sheet
2	Hopper Panel
3	Leg
4	Caulking
5	Bolt, Bin Seal 5/16-18 x 1"
6	Nut, Flange 5/16"-18

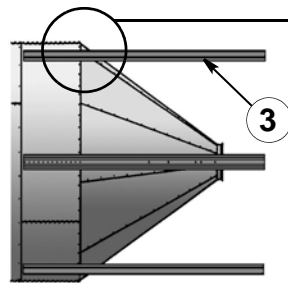
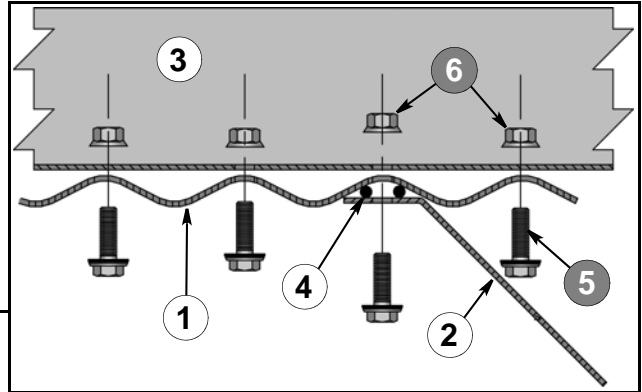

Figure 26.
Leg-to-Body Sheet Attachment at Hopper

9' [2 743] 60° Leg Attachment

A **Curved Washer** (Item 7) must be installed at the bottom Leg Bolt next to the Hopper Panel as indicated in **Figure 27**.

Apply Caulking on each side of the Hopper Panel at the connection to protect from moisture entering the bin at this point.

Item	Description
1	Body Sheet
2	Hopper Panel
3	Leg
4	Caulking
5	Bolt, Bin Seal
6	Nut, Flange
7	Washer, Curved, 12 ga. (39-20074)

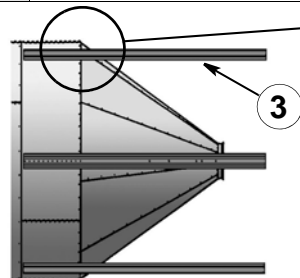
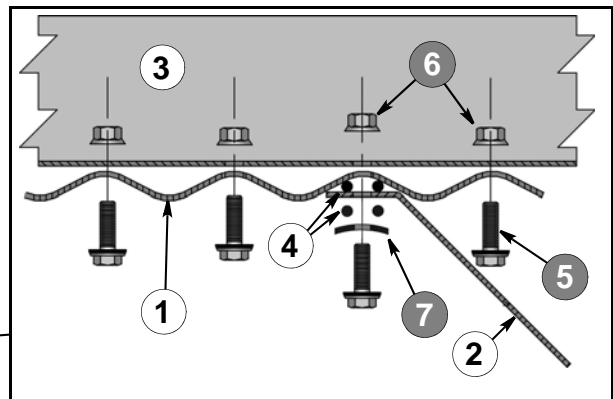

Figure 27.
9' [2 743] 60° Leg Attachment

Attach Leg Anchoring Assembly

Attach the Leg Anchor Assembly to the bottom of the Leg at three connections. Refer to Figure 28.

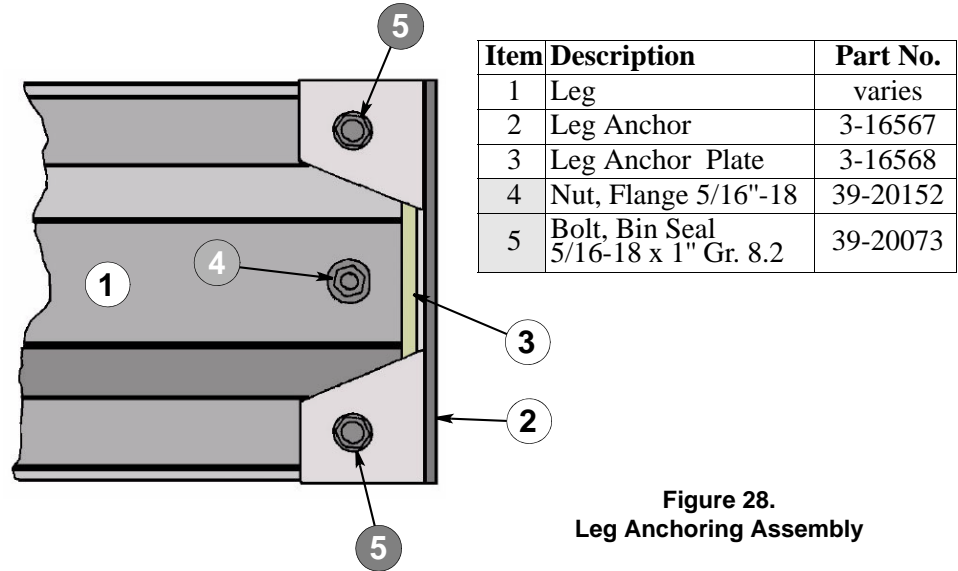

Figure 28. Leg Anchoring Assembly

Leg Anchor Weldment

Attach the Leg Anchor Weldment (Item 2) to the bottom of the Leg on the following bins:

- 6' [1 829]: 7-8 rings
- 7' [2 134]: 6-8 rings
- 9' [2 743]: 45° 11 rings
- 9' [2 743]: 60° 7-10 rings

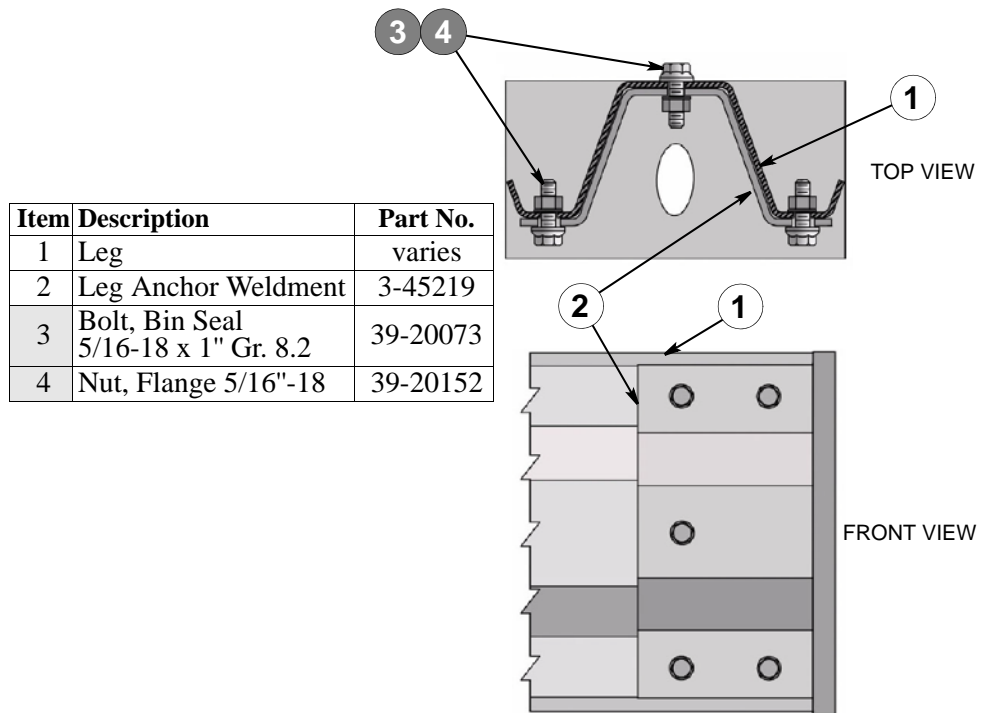

Figure 29. Leg Anchor Weldment

X-Brace Identification

X-Braces are marked with fluorescent green for Inside and fluorescent red for Outside. Install Inside Braces first.

Brace Attachment

Install the Hopper Braces and X-Braces to Legs using a 3/8 x 1" Hex Head Gr. 8 Bolts and 3/8" Nuts.

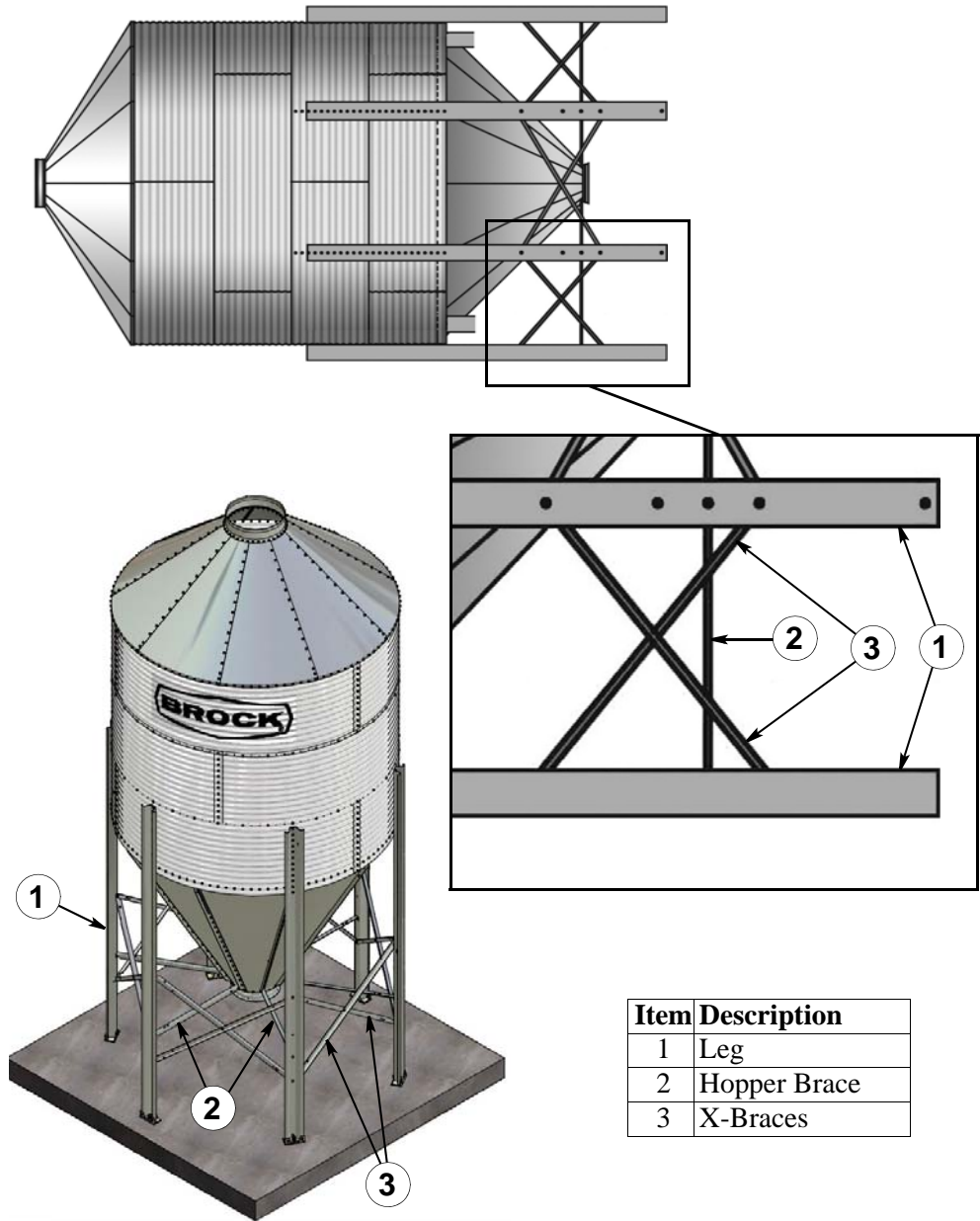

Figure 30.
Brace Attachment

Hopper Brace Attachment

Use 5/16 x 3/4" Truss Head Bin Seal Gr. 8.2 Bolts and 5/16" Flange Nuts to attach Hopper Brace to Collar. This hardware is packaged with the Collar.

The proper Collar/Brace diagram is shown with individual Bins on the Bin Assembly Diagrams on pages 32-39.

Standing the Bin Upright

Just before standing the bin upright, peel the cover paper off the BROCK® Decal while it is easy to reach.

To prevent damage to Legs when raising the bin, brace them with 2" x 4" [50 x 100] pieces of wood (Item 2) as shown in **Figure 31**. See the chart in **Figure 31** for the correct length.

CAUTION!



Check for all possible overhead obstructions, power lines, etc., BEFORE standing the bin on the foundation.

Raise the bin with extreme care. Small bins such as 6' [1 829] diameter, one or two rings, may be set up with manpower only. As the weight and length increase, this job becomes more difficult and a crane of adequate lifting capacity should be used.

Attach a sling, cable, or chain around the body of the bin just above the Legs.

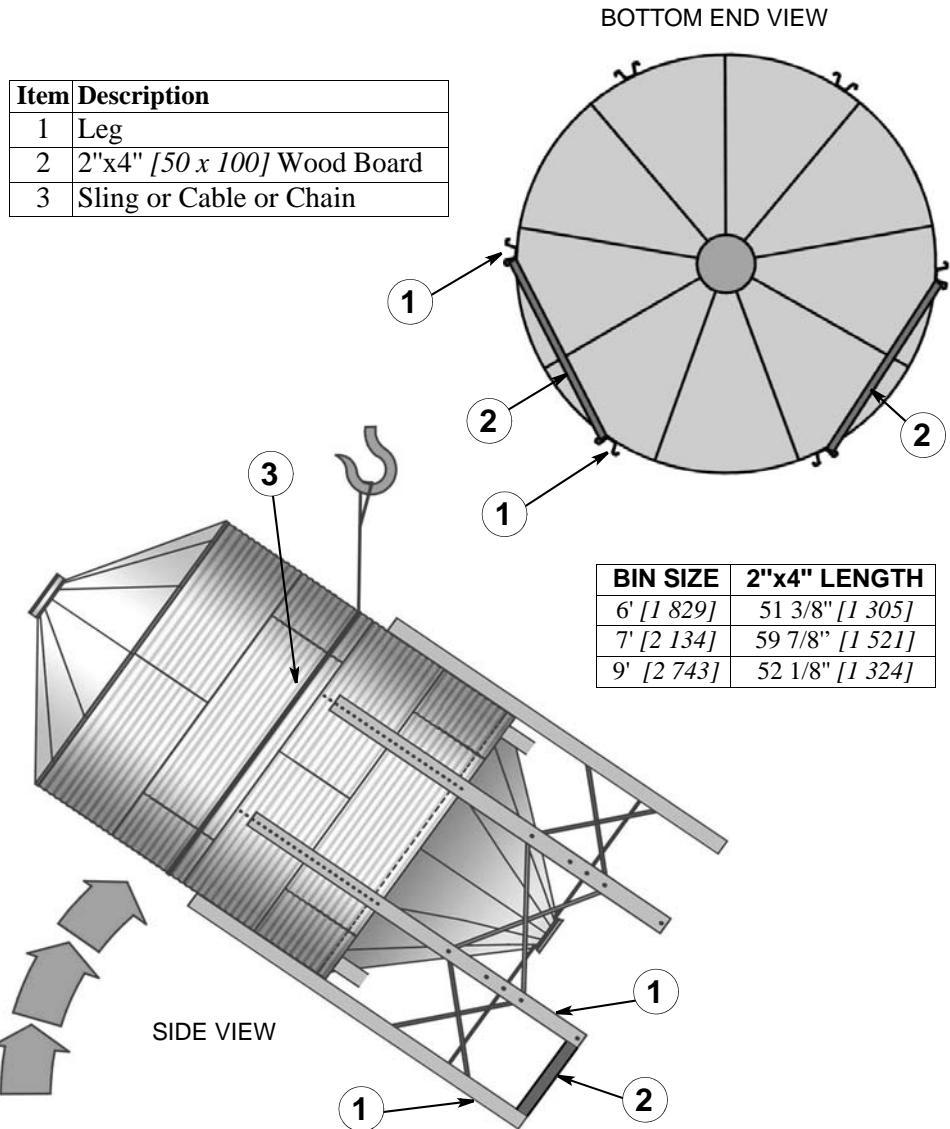

Figure 31.
Standing the Bin Upright

Standard Hopper Bin Leg Anchoring

CAUTION!



Measure between opposite Legs to be sure they are an equal distance apart before securing the Bin to Anchor Rods. Follow the chart shown. Failure to do so may cause damage to the Bin.

Bin Size	Distance Between Opposite Legs (X)
6' [1 829]	72 1/4" [1 835]
7' [2 134]	84 1/4" [2 140]
9' [2 743]	108 1/8" [2 746]

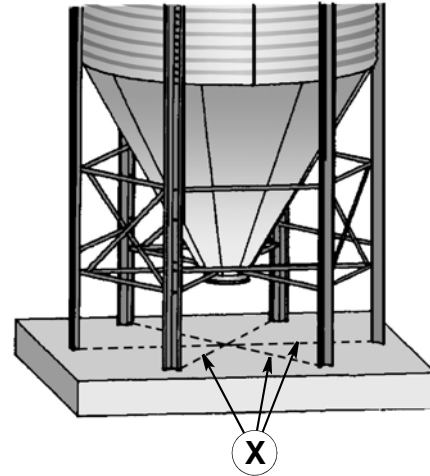
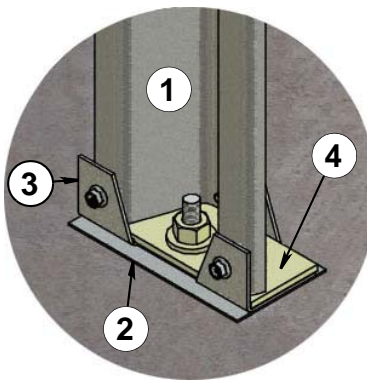

Figure 32.
Anchoring Measurements

See Pages 14, 15 and 27 for additional anchoring information.

Lower the Bin onto the Anchor Rods.

Place the 5/8" Heavy Washer (Item 7) over the Anchor Rod (Item 6) and finger-tighten the 5/8" Nut (Item 9). **Insert Concrete Shims (Item 2) as needed to level the bin** and make sure all Legs are resting firmly on the foundation. See Figure 33. Tighten all bolts.



Item	Description	Part No.
1	Leg	varies
2	Concrete Shim	9-18738
3	Leg Anchor	3-16567
4	Leg Anchor Plate	3-16568
5	Leg Anchor Weldment	3-45219
6	5/8 x 8 x 2" Anchor Bolt	39-20075
7	Washer, Heavy 5/8"	39-20077
8	Nut, Heavy Hex 5/8"-11	39-20364
9	Nut, Hex 5/8"-11	39-20076
10	Anchor Bolt, Heavy Hex Head 5/8-11 x 12"	39-20359
11	Washer, Octagon 5/8"	39-51026

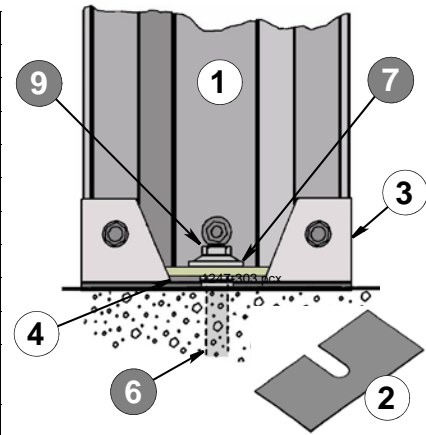

INSIDE (BACK) VIEW

Figure 33.
Standard Leg Anchoring

The Leg Anchor Weldment (Item 5) is attached to the bottom of the leg on the the following Bins:

- 6' [1 829] 60° 7-8 rings
- 7' [2 134] 67° 6-8 rings
- 9' [2 743] 45° 11 rings
- 9' [2 743] 60° 7-10 rings

These Leg anchors use the Heavy Anchor Bolt (Item 10), Heavy Nut (Item 8) and Octagon Washer (Item 11).

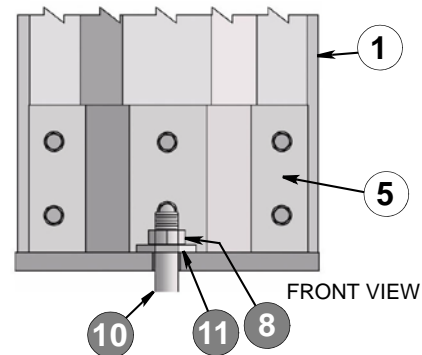

FRONT VIEW

Figure 33a.
Leg Anchor Weldment

Anchoring the Leg to Support Structure Beam

Support Structure and Foundation Designs are available from Brock on request. Other designs by Professional Engineers may be used.

Item	Part No.	Description
1	3-16567	Leg Anchor
2	3-16568	Leg Anchor Plate
3	not supplied	Support Structure Beam

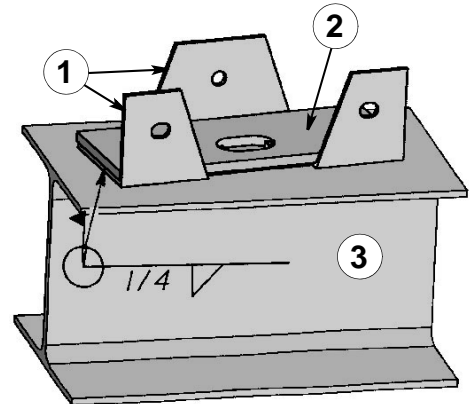

Figure 34.
Anchoring Leg to Support Structure Beam

Bin Grounding

All bins shall have **two** Ground Connections. Ground Rod Clamps must be spaced equally around the bin.

For alternate installations, cables may be placed in the foundation or through a PVC sleeve inserted in the slab during construction.

IMPORTANT! Make sure electrical equipment is properly installed and grounded by a qualified electrician according to the National Electrical Code.

NOTE: Parts should be purchased locally.

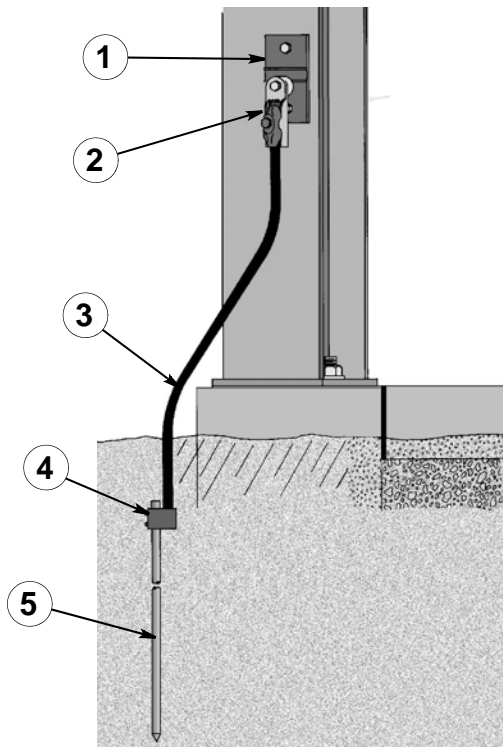

Item	Description
1	Heavy Duty Metal Bonding Plate
2	Swivel Cable Clamp
3	Copper Cable
4	Ground Rod Clamp
5	Ground Rod

Figure 35.
Bin Grounding

Hopper Bin Assembly Diagrams

6' [1 829] Diameter 60° Hopper Bin Specifications

* Sealant placement

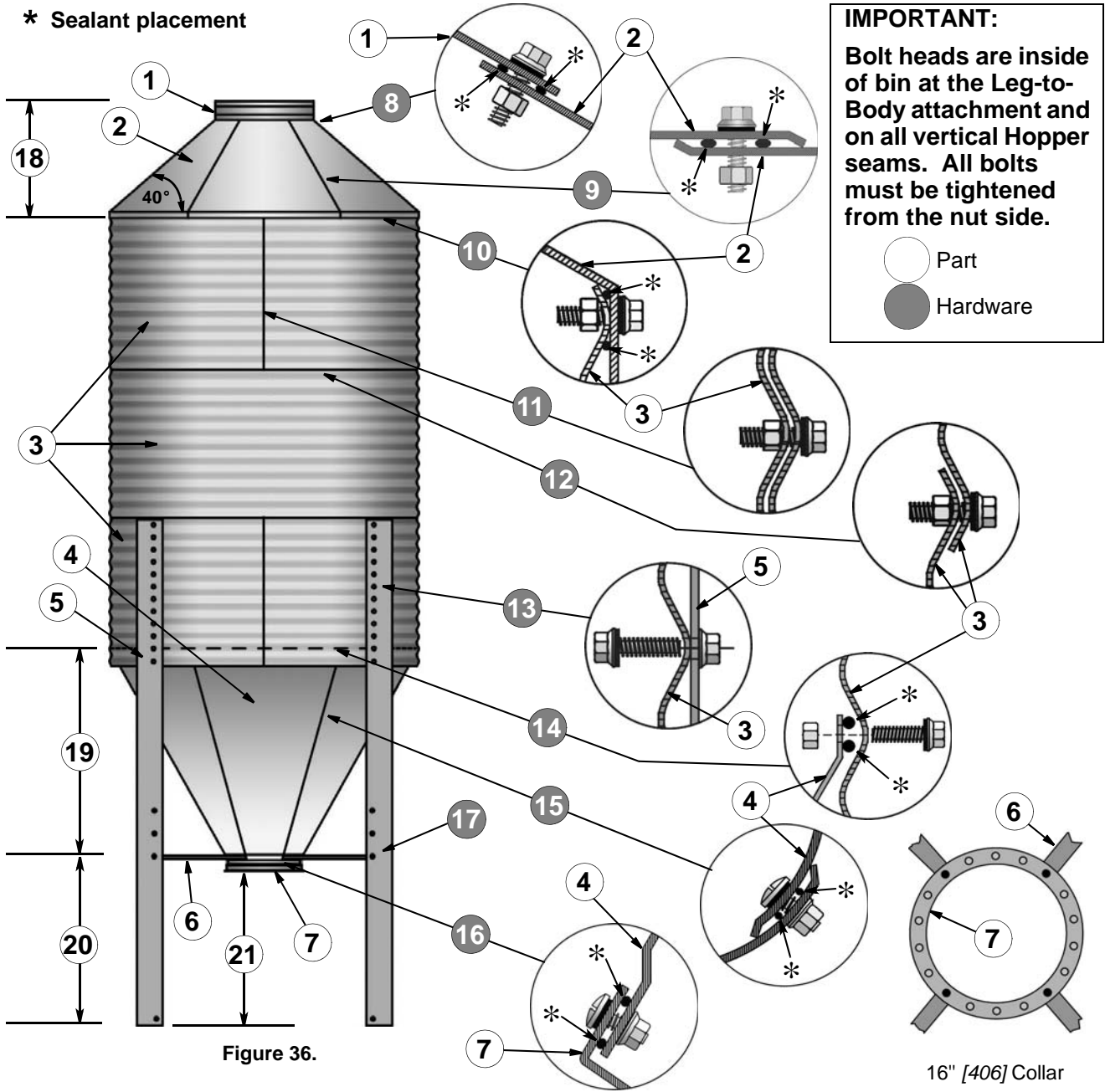
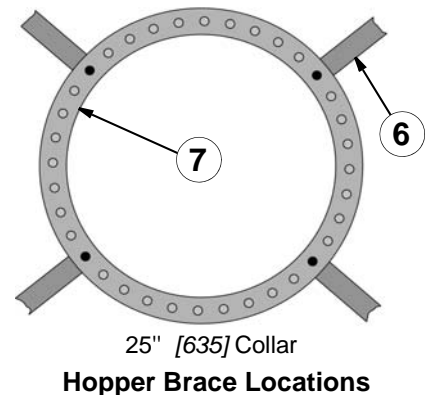

Figure 36.

BODY SHEET GAUGE CHART								
Body Sheet Rings	Model Numbers							
	00601	00602	00603	00604	00605	00606	00607	00608
top	20 ga.	20 ga.	20 ga.	20 ga.	20 ga.	20 ga.	20 ga.	20 ga.
2		20 ga.	20 ga.	20 ga.	20 ga.	20 ga.	20 ga.	20 ga.
3			20 ga.	19 ga.	19 ga.	19 ga.	18 ga.	18 ga.
4				19 ga.	17 ga.	17 ga.	16 ga.	16 ga.
5					17 ga.	15 ga.	15 ga.	15 ga.
6						15 ga.	13 ga.	13 ga.
7							13 ga.	13 ga.
8								13 ga.



6' [1 829] Diameter 60° Hopper Bin Parts List

Item	Part No.	Description	Qty.
1	3-32835	Fillhole Collar 22" [559]	1
2	3-33156	Roof Panel, 40° 22 ga.	6
3	6' [1 829] Body Sheets - 2 Body Sheets per ring		Color
	3-11374	20 ga. Body Sheet (top/mid) 2-8 rings	white
	3-33236	20 ga. Body Sheet (bottom/2-Leg) 1-3 rings	white
	3-33237	19 ga. Body Sheet (mid) 4-6 rings	brown
	3-33238	19 ga. Body Sheet (bottom/2-Leg) 4 rings	brown
	3-33239	18 ga. Body Sheet (mid) 7-8 rings	pink
	3-33240	17 ga. Body Sheet (mid) 6 rings	yellow
	3-33241	17 ga. Body Sheet (mid/2-Leg) 5 rings	yellow
	3-33242	17 ga. Body Sheet (bottom/2-Leg) 5 rings	yellow
	3-33243	16 ga. Body Sheet (mid) 7-8 rings	orange
	3-33244	15 ga. Body Sheet (mid) 7-8 rings	lt. blue
	3-33245	15 ga. Body Sheet (mid/2-Leg) 6 rings	lt. blue
	3-33246	15 ga. Body Sheet (bottom/2-Leg) 6 rings	lt. blue
	3-33247	13 ga. Body Sheet (mid) 8 rings	gray
	3-33248	13 ga. Body Sheet (mid/2-Leg) 7-8 rings	gray
3-33249	13 ga. Body Sheet (bottom/2-Leg) 7-8 rings	gray	
4	3-16607	Joggled Hopper Panel - 16" [406] 20 ga.	6 or
	3-11380	Hopper Panel - 25" [635] 20 ga.	6
5	3-33181	Leg 109 5/16" [2 777] O.A. 14 ga. 1-3 rings	4 or
	3-33182	Leg 109 5/16" [2 777] O.A. 12 ga. 4 rings	4 or
	3-33183	Leg 136" [3 454] O.A. 10 ga. 5-6 rings	4 or
	3-45214	Leg 136" [3 454] O.A. 8 ga. 7- 8 rings	4
6	3-13232	Hopper Brace for 16" [406] Collar	4 or
	3-11396	Hopper Brace for 25" [635] Collar	4
7	3-16888	16" [406] Hopper Collar 60°	1 or
	3-13284	25" [635] Collar and Plate Weldment 60°	1
IMPORTANT: All Bolts MUST be tightened from the Nut side. See Page 21.			
8	39-20073	Fillhole Collar to Roof Panels - Use 5/16 x 1" Bin Seal Gr. 8.2 Bolts	36
	39-20020	and 5/16" Hex Nuts.	36
9	39-20073	Roof Panel to Roof Panel - Use 5/16 x 1" Bin Seal Gr. 8.2 Bolts,	48
	39-20020	and 5/16" Hex Nuts.	48
10	39-20073	Roof Panels to Top Body Sheets - Use 5/16 x 1" Bin Seal Gr. 8.2 Bolts	72
	39-20020	and 5/16" Hex Nuts.	72
11	39-20073	Vertical Body Seams - Use 5/16 x 1" Bin Seal Gr. 8.2 Bolts	varies
	39-20020	and 5/16" Hex Nuts.	varies
12	39-20073	Horizontal Body Seams - Use 5/16 x 1" Bin Seal Gr. 8.2 Bolts	varies
	39-20020	and 5/16" Hex Nuts.	varies
13	39-20073	Leg Bolts - Use 5/16 x 1" Bin Seal Gr 8.2 Bolts, heads inside Bin,	48 or 96
	39-20152	and 5/16" Flange Nuts on the outside .	48 or 96
14	39-20073	Hopper Panels to Body Sheets - Use 5/16 x 1" Bin Seal Gr. 8.2 Bolts	68
	39-20020	and 5/16" Hex Nuts.	68
15	39-20145	Vertical Hopper Seams - Use 5/16 x 3/4" Truss Head Bin Seal Gr. 8.2	72
	39-20152	Bolts, heads inside Bin, and 5/16" Flange Nuts on outside .	72
16	39-20145	Collar to Hopper and Hopper Brace - Use 5/16 x 3/4" Truss Head Bin	18
	39-20152	Seal Gr. 8.2 Bolt, heads inside Bin, and 5/16" Flange Nuts outside .	18
17	39-20132	Hopper Braces to Legs - Use 3/8 x 1" Hex Head Gr. 8 Bolts	4
	39-20114	and 3/8" Hex Nuts.	4
18		26 3/4" [679]	
19		44 7/8" [1 140] (16" Hopper Brace)	
20		37 3/16" [945]	
21		34" [864] for 16" [406] Collar	
		43 7/8" [1 114] for 25" [635] Collar	

7' [2 134] Diameter 67° Hopper Bin Specifications

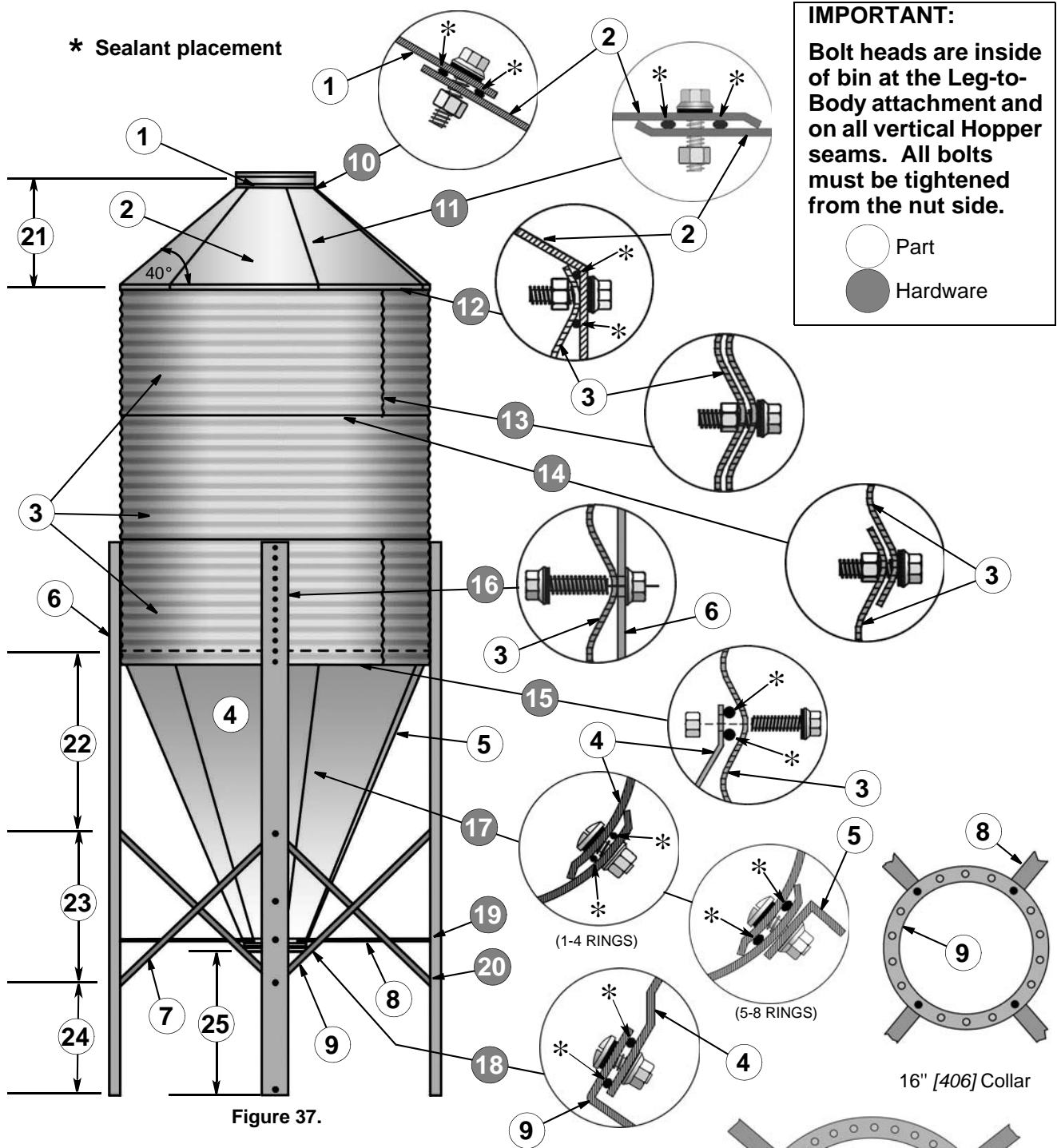
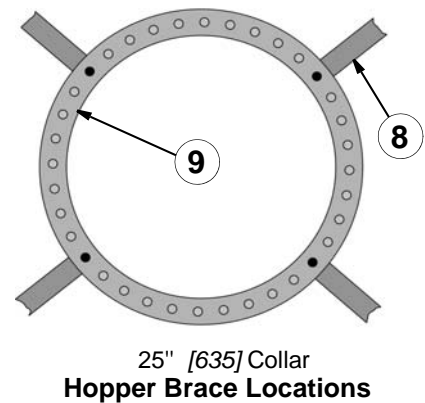

Figure 37.

BODY SHEET GAUGE CHART								
Body Sheet Rings	Model Numbers							
	00721	00722	00723	00724	00725	00726	00727	00728
top	20 ga.	20 ga.	20 ga.	20 ga.	20 ga.	20 ga.	20 ga.	20 ga.
2		20 ga.	20 ga.	20 ga.	20 ga.	20 ga.	20 ga.	20 ga.
3			20 ga.	19 ga.	19 ga.	18 ga.	18 ga.	18 ga.
4				18 ga.	17 ga.	17 ga.	16 ga.	16 ga.
5					17 ga.	15 ga.	14 ga.	14 ga.
6						15 ga.	13 ga.	13 ga.
7							13 ga.	13 ga.
8								13 ga.



7' [2 134] Diameter 67° Hopper Bin Parts List

Item	Part No.	Description	Qty.
1	3-32835	Fillhole Collar 22" [559]	1
2	3-33159	Roof Panel, 40° 22 ga.	6
		7' [2 134] Body Sheets - 2 sheets per ring	
			Color
3	3-13345	20 ga. Body Sheet (top/mid) 2-8 rings	white
	3-33250	20 ga. Body Sheet (bottom/2-Leg) 1-3 rings	white
	3-33251	19 ga. Body Sheet (mid) 4-5 rings	brown
	3-33135	18 ga. Body Sheet (mid) 6-8 rings	pink
	3-33252	18 ga. Body Sheet (bottom/2-Leg) 4 rings	pink
	3-33253	17 ga. Body Sheet (mid) 6 rings	yellow
	3-33254	17 ga. Body Sheet (mid/2-Leg) 5 rings	yellow
	3-33255	17 ga. Body Sheet (bottom/2-Leg) 5 rings	yellow
	3-33116	16 ga. Body Sheet (mid) 7-8 rings	orange
	3-33256	15 ga. Body Sheet (mid/2-Leg) 6 rings	lt. blue
	3-33257	15 ga. Body Sheet (bottom/2-Leg) 6 rings	lt. blue
	3-33258	14 ga. Body Sheet (mid) 7-8 rings	dk. green
	3-33259	13 ga. Body Sheet (mid) 8 rings	gray
	3-33260	13 ga. Body Sheet (mid/2-Leg) 7-8 rings	gray
3-33261	13 ga. Body Sheet (bottom/2-Leg) 7-8 rings	gray	
4	3-16609	Joggled Hopper Panel 16" [406] 18 ga.	6 or
	3-13349	Hopper Panel 25" [635] 18 ga.	6
5	3-16507	Hopper Reinforcement Angle 77 1/4" (1 962) O.A. length - 5-8 rings	6
6	3-33186	Leg 142 11/16" [3 624] O.A. 12 ga. 1-4 rings	4 or
	3-45215	Leg 169 7/16" [4 303] O.A. 10 ga. 5-6 rings	4 or
	3-45216	Leg 169 7/16" [4 303] O.A. 8 ga. 7-8 rings	4
7	3-27570	X-Brace (inside) 12 ga. fluorescent green	4
	3-27571	X-Brace (outside) 12 ga. fluorescent red	4
8	3-13351	Hopper Brace for 16" [406] Collar	4 or
	3-13352	Hopper Brace for 25" [635] Collar	4
9	3-16889	16" [406] Hopper Collar 67°	1 or
	3-31285	25" [635] Collar and Plate Weldment 67°	1
IMPORTANT: All Bolts MUST be tightened from the Nut side. See Page 21.			
10	39-20073	Fillhole Collar to Roof Panels -Use 5/16 x 1" Bin Seal Bolts Gr. 8.2	36
	39-20020	and 5/16" Hex Nuts.	36
11	39-20073	Roof Panel to Roof Panel - Use 5/16 x 1" Bin Seal Gr. 8.2 Bolts	60
	39-20020	and 5/16" Hex Nuts.	60
12	39-20073	Roof Panels to Top Body Sheets -Use 5/16 x 1" Bin Seal Gr. 8.2 Bolts	84
	39-20020	and 5/16" Hex Nuts.	84
13	39-20073	Vertical Body Seams - Use 5/16 x 1" Bin Seal Gr. 8.2 Bolts	varies
	39-20020	and 5/16" Hex Nuts.	varies
14	39-20073	Horizontal Body Seams - Use 5/16 x 1" Bin Seal Gr. 8.2 Bolts	varies
	39-20020	and 5/16" Hex Nuts.	varies
15	39-20073	Hopper Panels to Body Sheets - Use 5/16 x 1" Bin Seal Gr. 8.2 Bolts	80
	39-20020	and 5/16" Nuts.	80
16	39-20073	Leg Bolts -Use 5/16 x 1" Bin Seal Gr. 8.2 Bolts, heads inside Bin.	48 or 96
	39-20152	and 5/16" Flange Nuts outside .	48 or 96
17	39-20145	Vertical Hopper Seams - Use 5/16 x 3/4" Truss Head Bin Seal Gr. 8.2 Bolts,	180
	39-20152	heads inside Bin, and 5/16" Flange Nuts on outside .	180
18	39-20145	Collar to Hopper - Use 5/16 x 3/4" Truss Head Bin Seal Gr. 8.2 Bolts, heads	18
	39-20152	inside Bin, and 5/16" Flange Nuts outside .	18
19	39-20132	Hopper Braces to Legs - Use 3/8 x 1" Hex Head Gr. 8 Bolt	4
	39-20114	and 3/8" Hex Nuts.	4
20	39-20132	X-Braces to Legs and where the Braces cross - Use 3/8 x 1" Hex Head Gr. 8	12
	39-20114	Bolts and 3/8" Hex Nuts.	12
21		31 5/8" [803]	
22		51" [1 295]	
23		38 7/16" [976]	
24		26" [660]	
25		33 1/2" [851] for 16" [406] Collar	
		46 3/4" [1 187] for 25" [635] Collar	

9' [2 743] Diameter 45° Hopper Bin Specifications

* Sealant placement

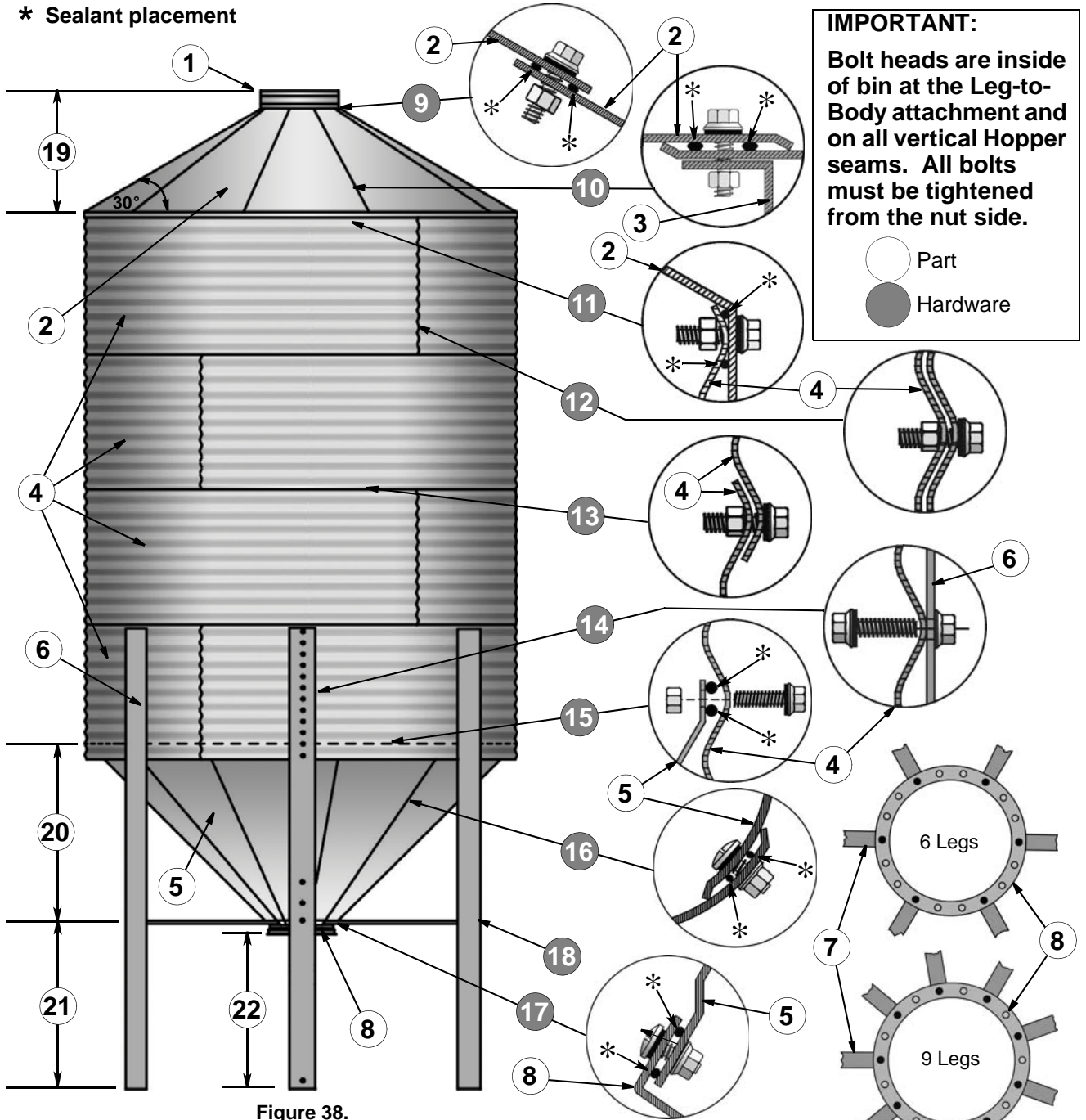
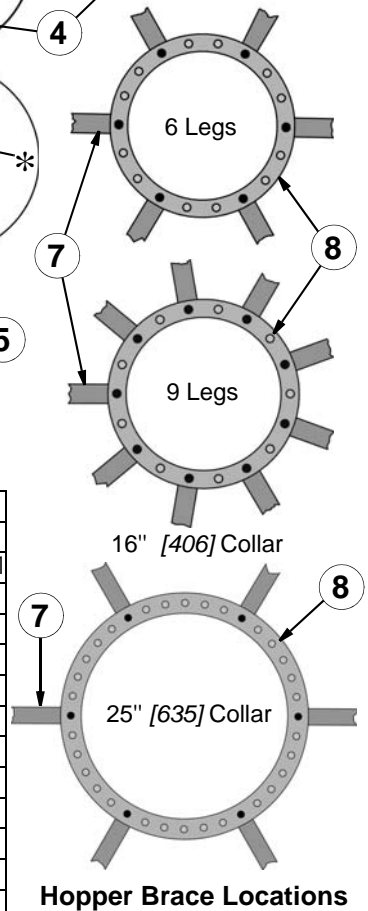

Figure 38.

BODY SHEET GAUGE CHART											
Body Sheet Rings	Model Numbers										
	00931	00932	00933	00934	00935	00936	00937	00938	00939	09310	09311
top	20 ga.	20 ga.	20 ga.	20 ga.	20 ga.	20 ga.	20 ga.	20 ga.	20 ga.	20 ga.	20 ga.
2		20 ga.	20 ga.	20 ga.	20 ga.	20 ga.	20 ga.	20 ga.	20 ga.	20 ga.	20 ga.
3			20 ga.	19 ga.	19 ga.	18 ga.	18 ga.	18 ga.	18 ga.	18 ga.	18 ga.
4				18 ga.	17 ga.	17 ga.	16 ga.	16 ga.	16 ga.	16 ga.	15 ga.
5					17 ga.	15 ga.	15 ga.	15 ga.	14 ga.	14 ga.	14 ga.
6						15 ga.	13 ga.	13 ga.	13 ga.	13 ga.	13 ga.
7							13 ga.	13 ga.	13 ga.	12 ga.	12 ga.
8								13 ga.	12 ga.	11 ga.	11 ga.
9									12 ga.	11 ga.	11 ga.
10										11 ga.	10 ga.
11											10 ga.



Hopper Brace Locations

9' (2 743) Diameter 45° Hopper Bin Parts List

Item	Part No.	Description	Color	Qty.
1	3-32835	Fillhole Collar 22" [559]		1
2	3-11451	Roof Panel, 30° 20 ga.		9
3	3-16041	Roof Reinforcement Angle 49 1/4" [1 251] 16 ga. (for use with Roof Ladder)		2
4	9' [2 743] Body Sheets - 3 Body Sheets per ring		Color	
	3-11452	20 ga. Body Sheet (top/mid) 2-11 rings	white	3/ring
	3-33262	20 ga. Body Sheet (bottom/2-Leg) 1-3 rings	white	
	3-33263	19 ga. Body Sheet (mid) 4-5 rings	brown	
	3-11453	18 ga. Body Sheet (mid) 6-11 rings	pink	
	3-33264	18 ga. Body Sheet (bottom/2-Leg) 4 rings	pink	
	3-33265	17 ga. Body Sheet (mid) 6 rings	yellow	
	3-33266	17 ga. Body Sheet (mid/2-Leg) 5 rings	yellow	
	3-33267	17 ga. Body Sheet (bottom/2-Leg) 5 rings	yellow	
	3-11454	16 ga. Body Sheet (mid) 7-10 rings	orange	
	3-33268	15 ga. Body Sheet (mid) 7, 8 and 11 rings	lt. blue	
	3-33269	15 ga. Body Sheet (mid/2-Leg) 6 rings	lt. blue	
	3-33270	15 ga. Body Sheet (bottom/2-Leg) 6 rings	lt. blue	
	3-11455	14 ga. Body Sheet (mid) 9-11 rings	dk. green	
	3-33271	13 ga. Body Sheet (mid) 8-11 rings	gray	
	3-33272	13 ga. Body Sheet (mid/2-Leg) 7 rings	gray	
	3-33273	13 ga. Body Sheet (bottom/2-Leg) 7 rings	gray	
	3-33373	13 ga. Body Sheet (mid/3-Leg) 8 rings	gray	
	3-33374	13 ga. Body Sheet (bottom/3-Leg) 8 rings	gray	
	3-33274	12 ga. Body Sheet (mid) 10-11 rings	dk. blue	
3-33275	12 ga. Body Sheet (mid/3-Leg) 9 rings	dk. blue		
3-33276	12 ga. Body Sheet (bottom/3-Leg) 9 rings	dk. blue		
3-33277	11 ga. Body Sheet (mid) 10-11 rings	lt. green		
3-33278	11 ga. Body Sheet (mid/3-Leg) 10 rings	lt. green		
3-33279	11 ga. Body Sheet (bottom/3-Leg) 10 rings	lt. green		
3-33280	10 ga. Body Sheet (mid/3-Leg) 11 rings	black		
3-33281	10 ga. Body Sheet (bottom/3-Leg) 11 rings	black		
5	3-16617	Joggled Hopper Panel 16" [406] 16 ga. 1-9 rings		9 or
	3-33513	Joggled Hopper Panel 16" [406] 14 ga. 10-11 rings		9
	3-16618	Hopper Panel 25" [635] 16 ga. 1-9 rings		9 or
	3-33514	Hopper Panel 25" [635] 14 ga. 10-11 rings		9
	6	3-33181	Leg 109 5/16" [2 777] O.A. 14 ga. 1-2 rings	
3-33182		Leg 109 5/16" [2 777] O.A. 12 ga. 3-4 rings		6 or
3-33183		Leg 136" [3 454] O.A. 10 ga. 5-6 rings		6 or
3-33183		Leg 136" [3 454] O.A. 10 ga. 8-9 rings		9
3-45214		Leg 136" [3 454] O.A. 8 ga. 7 rings		6 or
3-45214		Leg 136" [3 454] O.A. 8 ga. 10-11 rings		9
7	3-13234	Hopper Braces for 16" [406] Collar 1-7 rings		6 or
	3-13234	Hopper Braces for 16" [406] Collar 8-11 rings		9
	3-11469	Hopper Braces for 25" [635] Collar 1-7 rings		6 or
	3-11469	Hopper Braces for 25" [635] Collar 8-11 rings		9
8	3-16890	16" [406] Hopper Collar 45°		1 or
	3-13286	25" [635] Collar and Plate Weldment 45°		1
IMPORTANT: All Bolts MUST be tightened from the Nut side. See Page 21.				
9	39-20073	Fillhole Collar to Roof Panels -Use 5/16 x 1" Bin Seal Bolts Gr. 8.2		36
	39-20020	and Hex Nuts.		36
10	39-20073	Vertical Roof Seam (Use 5/16 x 1" Hex Head Bin Seal Gr. 8.2 Bolt		117
	39-20020	and 5/16" Hex Nuts.		117
11	39-20073	Roof Panel-to-top Body Sheets -Use 5/16 x 1" Bin Seal Gr. 8.2 Bolts		108
	39-20020	and Hex Nuts.		108
12	39-20073	Vertical Body Seams - Use 5/16 x 1" Bin Seal Gr. 8.2 Bolts		varies
	39-20020	and Hex Nuts.		varies
13	39-20073	Horizontal Body Seams - Use 5/16 x 1" Bin Seal Gr. 8.2 Bolts		varies
	39-20020	and Hex Nuts.		varies
14	39-20073	Leg Bolts (Bolt Heads are inside of Bin.) Use 5/16 x 1" Bin Seal Gr. 8.2 Bolts		72 (2-4 ring)
	39-20152	and Flange Nuts outside .		144 (5-7 ring) 216 (8-11 ring)
15	39-20073	Hopper Panels to Body Sheets - Use 5/16 x 1" Bin Seal Gr. 8.2 Bolts		102 (1-7 ring)
	39-20020	and Hex Nuts.		99 (8-11 ring)
16	39-20145	Vertical Hopper Seams - Use 5/16 x 3/4" Truss Head Bin Seal Gr. 8.2 Bolts,		135 (1-9 ring)
	39-20152	heads inside Bin, and Flange Nuts outside .		180 (10-11 ring)
17	39-20145	Collar to Hopper - Use 5/16 x 3/4" Truss Head Bin Seal Gr. 8.2 Bolts, heads		18
	39-20152	inside Bin, and Flange Nuts outside .		
18	39-20132	Hopper Brace to Leg - Use 3/8 x 1" Hex Head Gr. 8 Bolts		6 (1-7 ring)
	39-20114	and 3/8" Hex Nuts.		9 (8-11 ring)
19		30 3/8" [772]		
20		44 7/8" [1 140] (16" Hopper Brace)		
21		37 3/16" [945]		
22		32 3/4" [832] for 16" [406] Collar		
		40 1/4" [1 022] for 25" [635] Collar		

9' [2 743] Diameter 60° Hopper Bin Specifications

* Sealant placement

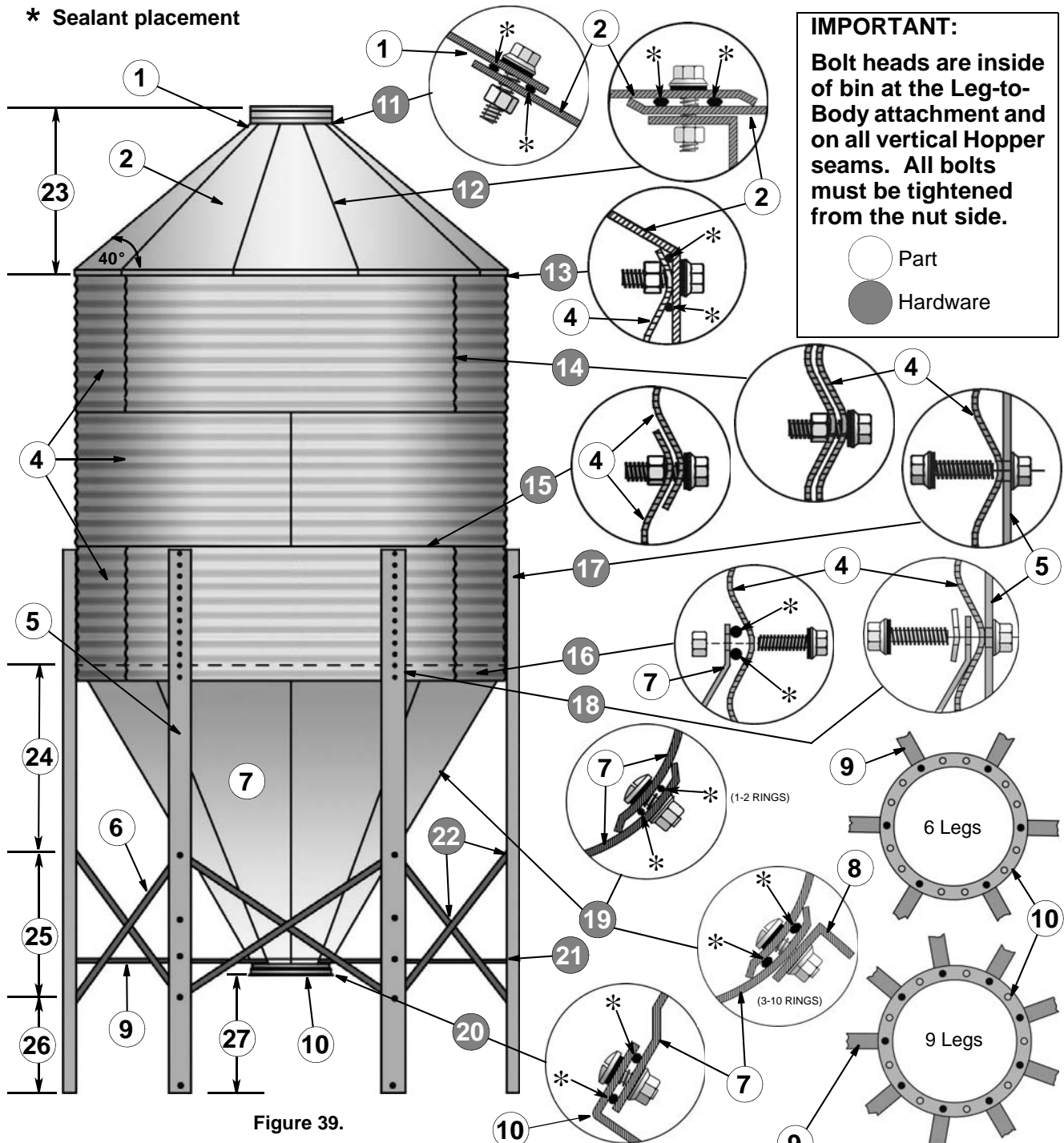
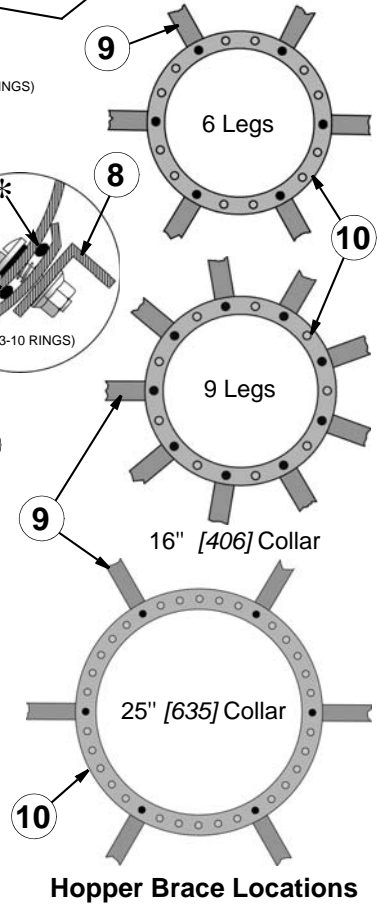

Figure 39.

BODY SHEET GAUGE CHART										
Body Sheet Rings	Model Numbers									
	00901	00902	00903	00904	00905	00906	00907	00908	00909	00910
top	20 ga.	20 ga.	20 ga.	20 ga.	20 ga.	20 ga.	20 ga.	20 ga.	20 ga.	20 ga.
2		20 ga.	20 ga.	20 ga.	20 ga.	20 ga.	20 ga.	20 ga.	19 ga.	19 ga.
3			20 ga.	19 ga.	19 ga.	18 ga.	18 ga.	18 ga.	18 ga.	18 ga.
4				18 ga.	17 ga.	17 ga.	16 ga.	16 ga.	16 ga.	16 ga.
5					17 ga.	15 ga.	15 ga.	15 ga.	14 ga.	14 ga.
6						15 ga.	13 ga.	13 ga.	13 ga.	13 ga.
7							13 ga.	13 ga.	13 ga.	12 ga.
8								13 ga.	12 ga.	11 ga.
9									12 ga.	11 ga.
10										11 ga.



9' [2 743] Diameter 60° Hopper Bin Parts List

Item	Part No.	Description	Qty.
1	3-32835	Fillhole Collar 22" [559]	1
2	3-33162	Roof Panel, 40° 20 ga.	9
3	3-33416	9' [2 743] 40° Roof Reinforcement Angles 53 1/4" [1 353] long 16 ga. (for use with Roof Ladder)	2
4	9' [2 743] Body Sheets - 3 sheets per ring		Color
	3-11452	20 ga. Body Sheet (top/mid) 2-10 rings	white
	3-33262	20 ga. Body Sheet (bottom/2-Leg) 1-3 rings	white
	3-33263	19 ga. Body Sheet (mid) 4-5 rings	brown
	3-11453	18 ga. Body Sheet (mid) 6-10 rings	pink
	3-33264	18 ga. Body Sheet (bottom/2-Leg) 4 rings	pink
	3-33265	17 ga. Body Sheet (mid) 5-6 rings	yellow
	3-33267	17 ga. Body Sheet (bottom/2-Leg) 5 rings	yellow
	3-11454	16 ga. Body Sheet (mid) 7-10 rings	orange
	3-33268	15 ga. Body Sheet (mid) 7-8 rings	lt. blue
	3-33269	15 ga. Body Sheet (mid/2-Leg) 6 rings	lt. blue
	3-33270	15 ga. Body Sheet (bottom/2-Leg) 6 rings	lt. blue
	3-11455	14 ga. Body Sheet (mid) 9-10 rings	dk. green
	3-33271	13 ga. Body Sheet (mid) 8-10 rings	gray
	3-33272	13 ga. Body Sheet (mid/2-Leg) 7-8 rings	gray
	3-33273	12 ga. Body Sheet (bottom/2-Leg) 7-8 rings	dk. blue
	3-33274	12 ga. Body Sheet (mid) 10 rings	dk. blue
3-33375	12 ga. Body Sheet (mid/2-Leg) 9 rings	dk. blue	
3-33376	12 ga. Body Sheet (bottom/2-Leg) 9 rings	dk. blue	
3-33277	11 ga. Body Sheet (mid) 10 rings	lt. green	
3-33377	11 ga. Body Sheet (mid/2-Leg) 10 rings	lt. green	
3-33378	11 ga. Body Sheet (bottom/2-Leg) 10 rings	lt. green	
5	3-33186	Leg 142 11/16" [3 624] O.A. 12 ga. 1-5 rings	6 or
	3-45215	Leg 169 3/8" [4 302] O.A. 10 ga. 6-8 rings	6 or
	3-45216	Leg 169 3/8" [4 302] O.A. 8 ga. 9-10 rings	6
6	3-27572	9' [2 743] X-Brace (inside) fluorescent green, 12 ga., 1-9 rings	6
	3-27573	9' [2 743] X-Brace (outside) fluorescent red, 12 ga., 1-9 rings	6
	3-33609	9' [2 743] X-Brace (inside) fluorescent green, 10 ga., 10 rings	6
	3-33610	9' [2 743] X-Brace (outside) fluorescent red, 10 ga., 10 rings	6
7	3-16613	Joggled Hopper Panel 16" [406] 18 ga. (1-8 rings)	9 or
	3-16615	Joggled Hopper Panel 16" [406] 16 ga. (9-10 rings)	9
	3-11463	Hopper Panel 25" [635] 18 ga. (1-8 rings)	9 or
	3-16099	Hopper Panel 25" [635] 16 ga. (9-10 rings)	9
8	3-22597	9' [2 743] Hopper Reinforcement Angle - 12 ga., 87 1/4" [2 223] O.A. (3-10 rings)	9
9	3-13235	Hopper Brace for 16" [406] Collar	6 or
	3-11469	Hopper Brace for 25" [635] Collar	6
10	3-16888	Hopper Collar 16" [406] 60°	1 or
	3-13284	Collar and Plate Weldment 25" [635] 60°	1
IMPORTANT: All Bolts MUST be tightened from the Nut side. See Page 21.			
11	39-20073	Fillhole Collar to Roof Panels -Use 5/16 x 1" Bin Seal Gr. 8.2 Bolts	36
	39-20020	and 5/16" Hex Nuts.	36
12	39-20073	Roof Panel to Roof Panel - Use 5/16 x 1" Bin Seal Gr. 8.2 Bolts	126
	39-20020	and 5/16" Hex Nuts.	126
13	39-20073	Roof Panels to Body Sheets -Use 5/16 x 1" Bin Seal Gr. 8.2 Bolts	108
	39-20020	and 5/16" Hex Nuts.	108
14	39-20073	Vertical Body Seams - Use 5/16 x 1" Bin Seal Gr. 8.2 Bolts	varies
	39-20020	and 5/16" Hex Nuts.	varies
15	39-20073	Horizontal Body Seams - Use 5/16 x 1" Bin Seal Gr. 8.2 Bolts	varies
	39-20020	and 5/16" Hex Nuts.	varies
16	39-20073	Hopper Panels to Body Sheets - Use 5/16 x 1" Bin Seal Gr. 8.2 Bolts	102
	39-20020	and 5/16" Hex Nuts.	102
17	39-20073	Leg Bolts - Use 5/16 x 1" Bin Seal Gr. 8.2 Bolts, heads INSIDE Bin,	66 or 138
	39-20152	and 5/16" Flange Nuts outside .	66 or 138
18	39-20074	Leg-to-Body Sheet-to-Hopper Connection - (Use 12 ga. Washer under 5/16 x 1" Gr. 8.2	6
	39-20073	Bin Seal Bolts, heads inside Bin, and Flange Nut outside .	6
	39-20152		6
19	39-20145	Vertical Hopper Seams - Use 5/16 x 3/4" Truss Head Bin Seal Gr. 8.2 Bolts, heads inside	252
	39-20152	Bin, and 5/16" Flange Nuts outside .	252
20	39-20145	Collar to Hopper - Use 5/16 x 3/4" Truss Head Bin Seal Gr. 8.2 Bolts, heads inside Bin,	18
	39-20152	and Flange Nuts outside .	18
21	39-20132	Hopper Braces to Legs - Use 3/8 x 1" Gr. 8 Bolts	6
	39-20114	and 3/8" Hex Nuts.	6
22	39-20132	X-Braces to Legs - Use 3/8 x 1" Hex Head Gr. 8 Bolts	18
	39-20114	and 3/8" Hex Nuts	18
23		41 7/8" [1 064]	
24		51" [1 295]	
25		38 7/16" [976]	
26		26" [660]	
27		32 3/4" [832] for 16" [406] Collar; 43 3/4" [1 111] for 25" [635] Collar	



DIFFERENT BY DESIGN®

BROCK GRAIN SYSTEMS
A Division of CTB Inc.

P.O. Box 2000 • Milford, Indiana 46542-2000 • U.S.A.
Phone (574) 658-4191 • Fax (574) 658-4133
e-mail: brock@brockgrain.com • Internet: <http://www.brockgrain.com>

Printed in the U.S.A.

All specifications subject to change without notice.

Changes this issue:

There were miscellaneous trademark updates.

Foot weldment used on some models now requires Octagon Washer instead of Heavy Washer.

Anchor information was updated.

Changes last issue:

There were miscellaneous additions and corrections.

NOTE: The original, authoritative version of this Manual is the [English] version produced by CTB, Inc. or any of its subsidiaries or divisions, (hereafter collectively referred to as "CTB"). Subsequent changes to any Manual made by any third party have not been reviewed nor authenticated by CTB. Such changes may include, but are not limited to, translation into languages other than [English], and additions to or deletions from the original content. CTB disclaims responsibility for any and all damages, injuries, Warranty claims and/or any other claims associated with such changes, inasmuch as such changes result in content that is different from the authoritative CTB-published [English] version of the Manual. For current product installation and operation information, please contact the Customer Service and/or Technical Service Departments of the appropriate CTB subsidiary or division. Should you observe any questionable content in any Manual, please notify CTB immediately in writing to: CTB Legal Department, P.O. Box 2000, Milford, IN 46542-2000 USA.