

CONSTRUCTION MANUAL



12', 15', 18' and 21'
[3 658, 4 572, 5 486 and 6 401 mm] Dia.
HOPPER BINS



Warranty

Brock Grain Systems (“BROCK”) warrants each new BROCK® Commercial Grain Bin* manufactured by it to be free from defects in material or workmanship for five years from and after the date of initial installation by or for the original purchaser. If such a defect is found by the Manufacturer to exist within the five-year period, the Manufacturer will, at its option, (a) repair or replace such product free of charge, F.O.B. the factory of manufacture, or (b) refund to the original purchaser the original purchase price, in lieu of such repair or replacement. Labor costs associated with the replacement or repair of the product are not covered by the Manufacturer.

CONDITIONS AND LIMITATIONS

1. The product must be installed by and operated in accordance with the instructions published by the Manufacturer or Warranty will be void.
2. Warranty is void if all components of the system are not original equipment supplied by the Manufacturer.
3. This product must be purchased from and installed by an authorized dealer or certified representative thereof or the Warranty will be void.
4. Malfunctions or damage resulting from misuse, abuse, negligence, alteration, accident, or lack of proper maintenance shall not be considered defects under the Warranty.
5. This Warranty applies only to systems for the care of grain and feed. Other applications in industry or commerce are not covered by this Warranty.

* Painted parts are only warranted for one year against surface rust.

The Manufacturer shall not be liable for any consequential or special damage which any purchaser may suffer or claim to suffer as a result of any defect in the product. “Consequential” or special damages” as used herein include, but are not limited to, lost or damaged products or goods, costs of transportation, lost sales, lost orders, lost income, increased overhead, labor and incidental costs and operational inefficiencies.

THIS WARRANTY CONSTITUTES THE MANUFACTURER’S ENTIRE AND SOLE WARRANTY AND THIS MANUFACTURER EXPRESSLY DISCLAIMS ANY AND ALL OTHER WARRANTIES, INCLUDING, BUT NOT LIMITED TO, EXPRESS AND IMPLIED WARRANTIES AS TO MERCHANTABILITY, FITNESS FOR PARTICULAR PURPOSES SOLD AND DESCRIPTION OR QUALITY OF THE PRODUCT FURNISHED HEREUNDER.

BROCK dealers are not authorized to modify or extend the terms and conditions of this Warranty in any manner or to offer or grant any other warranties for BROCK® products in addition to those terms expressly stated above. An officer of CTB, Inc. must authorize any exceptions to this Warranty in writing. The Manufacturer reserves the right to change models and specifications at any time without notice or obligation to improve previous models.

Effective March 2016

BROCK GRAIN SYSTEMS
 A Division of CTB Inc.
 P.O. Box 2000 • Milford, Indiana 46542-2000 • U.S.A.
 Phone (574) 658-4191 • Fax (574) 658-4133
 e-mail: brock@brockgrain.com • Internet: <http://www.brockgrain.com>

Thank You

The employees of BROCK GRAIN SYSTEMS would like to thank your for your recent BROCK® purchase. If a problem should arise, your BROCK dealer can supply the necessary information to help you.

Remember! Think SAFETY First!



This symbol is used throughout this Manual to identify particular stages where the bin Contractor and/or Operator need to take special note and precautions regarding the DANGER described in these Instructions. Please read all the SAFETY information and the Instructions completely prior to beginning the construction.

Contents

Warranty	2
General	4
Remember! Think SAFETY First!	4
Support Information	4
About This Manual	5
Identification of Parts and Hardware	5
Planning Before Your Bin Arrives	6
Choose The Bin Site • Check Delivery	6
Tools and Equipment Needed	6
SAFETY	7-15
Recognize SAFETY Information • Understand Signal Words	7
Follow SAFETY Instructions	7
Electrical SAFETY	8
DANGER, WARNING and CAUTION Decals	8-12
Suffocation Hazards in Flowing Grain	13
Safety Hazards and Recommendations	14
In the Event of Emergency: Possible Corrective Measures	14
Considerations that may result in a hazard, damage your bin and/or void your Warranty	15
Foundations	16-20
Anchoring	16
Alternate Anchoring	17
Specifications	18-19
Concrete Charts	20
Body Sheet Assembly	21-22
Body Sheet Identification • Body Sheet Gauges	21
Caulking (Sealant) Is Critical!	21
Hardware Connections • Overview	22
Hopper Bin Roof (Closed Eave)	24-25
Planning the Roof	24
Roof Panels • Roof Reinforcement Angles • Fillhole and Lid	25
Hopper Bin Roof (Raised Rib) and Tank Lifting	26-28
Lifting and Assembling the Tank	26
Choosing the Proper Jacks to Lift the Tank • SAFETY Procedures While Lifting the Tank	26
Adding Body Sheet Rings • Legs	28
Hopper Assembly	29-30
Hopper Panels	29
Hopper Collar • Hopper Reinforcement Angle	30
Legs and Braces	31-32
Hopper Braces to Legs	31
X-Braces Between Legs	31
Standard Hopper Bin Leg Anchoring	31
Anchoring the Leg to Support Structure Beam	32
Bin Grounding	33
Bin Assembly Diagrams	34-45
12' [3 658] Diameter 45° Hopper Bin	34-35
12' [3 658] Diameter 60° Hopper Bin	36-37
15' [4 572] Diameter 45° Hopper Bin	38-39
15' [4 572] Diameter 60° Hopper Bin	40-41
18' [5 486] Diameter 45° Hopper Bin	42-43
21' [6 401] Diameter 45° Hopper Bin	44-45

General

Support Information

BROCK® products are designed for grains and/or free flowing materials. **Using this equipment for any other purpose or in a way not within the operating recommendations specified in this Manual will void the Warranty and may cause injury or death.** This Manual is designed to provide comprehensive planning and construction information for this BROCK® product. The Table of Contents provides a convenient overview of the information in this Manual.

Dealers: Please provide the Customer with the information to complete the easy reference below.

Dealer or Customer: Complete the following information about your BROCK® product.

Distributor and Installer Information

Please fill in the following information about your Product.
Keep this Manual in a clean, dry place for future reference.

Distributor's Name _____

Distributor's Address _____

Distributor's Phone _____ **Date of Purchase** _____

Installer's Name _____

Installer's Address _____

Installer's Phone _____ **Date of Installation** _____

System Specifications _____

Check Delivery

Your Grain Bin is made up of many parts and checked carefully at the time of shipment. However, use the packing slip and check your shipment on arrival to be sure it is complete.

IMPORTANT! *How to control "Wet Storage Stain" (RUST!) on galvanized Body Sheets: Do not permit moisture from weather, condensation, or other sources to remain between Body Sheets. If moisture is present, separate the Sheets IMMEDIATELY for good air circulation. Where possible, store all Bin components in a warm, dry place away from contaminants such as fertilizer, chemicals and road salt. If this is not done, white/red rust will appear.*

About This Manual

The intent of this Manual is to help you in two ways. One is to follow step-by-step in the assembly order of your Hopper Bin. The other way is for easy reference if you have questions in a particular area.

IMPORTANT! *Read this Base Construction Manual and ALL Supplemental Manuals carefully before starting construction.*

IMPORTANT! *Pay particular attention to all SAFETY information on pages 7-15.*

Major changes from the last printing are listed on the back cover.

Optional equipment contains necessary instructions for assembly or operation.

Follow recommended precautions and safe operating practices of national and/or local codes at each installation site.

• **Measurements:** In English measurements, listed first, the symbol " equals **inches** and ' equals **feet**. Metric measurements follow the English measurement. Metrics are shown in *italics* inside square brackets. The metric measurement is in **millimeters** unless otherwise specified. English/metric measurement example:
 12' diameter = 3 658 mm 15' diameter = 4 572 mm
 18' diameter = 5 486 mm 21' diameter = 6 401 mm

• **Orientation and direction:** "Horizontal," "vertical," "bottom," and "top" refer to the Grain Bin as it is **standing**. "Left" and "right" refer to the Grain Bin as you are looking at it from the **outside**.

• This **Planning Symbol** is used in areas where planning needs to take place **before** construction continues. When you see the Planning symbol at left, decisions must be made regarding your particular installation.



Identification of Parts and Hardware

IMPORTANT! *No hardware substitutions are permitted.* Grade 8.2 Hex Head Bolts are identified with Grade markings such as in **Figure 1**.

All body and Roof seams use 5/16 x 1" Grade 8.2 Hex Head Bin Seal Bolts (with markings as shown in **Figure 1**) and Hex Nuts, or the optional Plastic Head Bolts, with the heads on the **outside** of the Grain Bin.

All Leg-to-Body Bolts have the heads on the **inside** of the Bin

Many assemblies described in this Manual have accompanying **Figures**. To identify components, **Figures** use Item keys with corresponding Item Tables. Tables common to more than one **Figure** may be shared.

- **Items** identified include basic parts, hardware, and other parts pertinent to the assembly or step. Items keyed will vary among **Figures**.
- The Item key for basic **parts** and components is a black number in white circle.
- The Item key for **hardware** (and/or hardware **connections** between Parts) is a white number in a shaded circle.
- The Item key for dimensions and lengths (variable or set) is a number/letter in a circle **on** an arrow or line. Numeric values are listed in the Item Table.
- An **asterisk*** notes other specifics, which may include holes, notches, positions, or exceptions, etc.

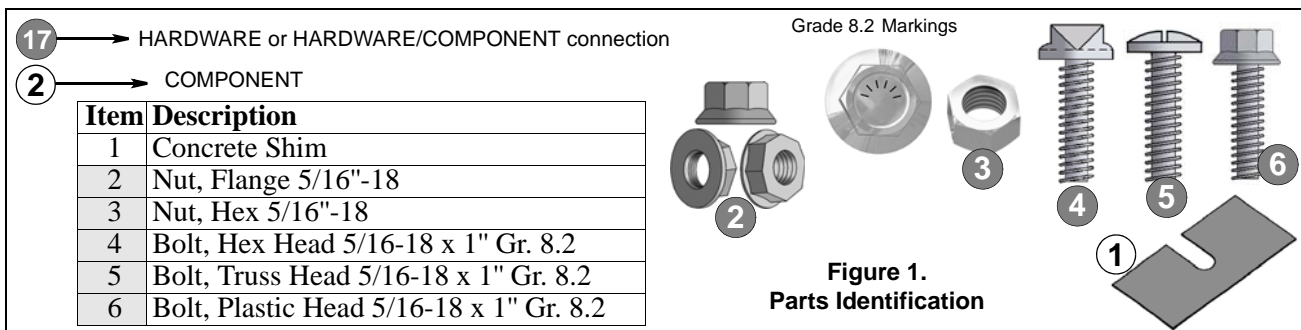

Planning Before Your Bin Arrives

Choose The Bin Site

Select the site of your Grain Bin with care. Planning for future expansion is of prime consideration. The soil area for your Hopper Bin(s) should be firm and well drained with a uniform bearing capacity of at least 3000 pounds per square foot [14 647 kg/m] or special modification of foundations must be considered.

Check Delivery

Your Grain Bin is made up of many parts and checked carefully at the time of shipment. However, use the packing slip and check your shipment on arrival to be sure it is complete.

IMPORTANT!

How to control "Wet Storage Stain" (RUST!) on galvanized Body Sheets: Do not permit moisture from weather, condensation, or other sources to remain between Body Sheets. If moisture is present, separate the Sheets IMMEDIATELY for good air circulation. Where possible, store all Bin components in a warm, dry place away from contaminants such as fertilizer, chemicals and road salt. If this is not done, white/red rust will appear.

The paper cover on the BROCK® Decal helps prevent damage to the Decal during Bin construction. However, it may be difficult to remove if left in direct sunlight for several hours.



Tools and Equipment Needed

- 7/16" - 1" Box End Wrenches
- Adjustable Wrenches up to 1-1/2" [38] for adjustable expanders
- 12" [305] Long Drift Punches
- Drill
- Hammer
- Screwdriver
- Speed Wrench and Sockets
- Impact Wrench and Sockets
- Lifting Jacks
- Lifting Brackets
- Protective gloves and eyewear
- Nail aprons to hold a supply of bolts and nuts during assembly

IMPORTANT!

The number of lifting jacks and brackets required is determined by factors such as Grain Bin size, soil compaction, wind velocity, design of jacks, etc.

Keep these figures in mind when determining the number of bolts needed to lift a bin during assembly.

A 5/16" Grade 8.2 Bin Seal Bolt has an approximate safe load of 1,840 lbs [835 kg].

A 3/8" Grade 8.2 Bin Seal Bolt has an approximate safe load of 2,650 lbs [1 202 kg].

Tighten 5/16" Nuts to 15-20 ft-lb [20-27 N-m] of torque.

Tighten 3/8" Nuts to 25-30 ft-lb [34-41 N-m] of torque.

SAFETY**Recognize SAFETY Information**

This is the Safety-Alert Symbol. When you see this symbol on your equipment or in this Manual, be alert to the potential for personal injury.

Signal words **DANGER**, **WARNING**, or **CAUTION**, are used with the Safety-Alert Symbol.

Understand Signal Words

DANGER indicates an imminently hazardous situation which, if not avoided, **WILL** result in death or serious injury.



WARNING indicates a potentially hazardous situation which, if not avoided, **COULD** result in death or serious injury.



CAUTION indicates a hazardous situation which, if not avoided, **MAY** result in minor or moderate injury.

Follow SAFETY Instructions

Carefully read all SAFETY messages in this Manual and on your equipment SAFETY signs. Follow recommended precautions and safe operating practices.

Keep SAFETY signs in good condition. Replace missing or damaged SAFETY signs.

For operation and use of your Hopper bin, read and understand the Owner's/Operator's Manual.

WARNING!



Failure to follow proper assembly and operational procedures may cause damage to equipment or personal injury.

CAUTION!



Bin installations shall meet the National Fire Protection Association Standard 61B for the prevention of fires and explosions in grain elevators and facilities handling bulk raw agricultural commodities.

SAFETY**Electrical SAFETY**

In selecting electrical control equipment to be used with any installation, the purchaser must use equipment conforming to the National Electrical Code, the National Electrical Safety Code and all other applicable local or national codes or regulations.

Important consideration should be given to some or all of the following devices and to others which may be appropriate:

1. **Overload protection devices** such as shear pins, torque limiters, zero speed switches, etc., to shut off and lock out power whenever operation of equipment is stopped as a result of excessive material, foreign objects, excessively large lumps, etc.
2. **Safety shut-off switch** with power lockout provisions at auger drive.
3. **Emergency stop switches** readily accessible wherever required.
4. **Electrical interlocking** to shut down the feeding auger whenever a receiving auger stops.
5. **Signal devices to warn personnel** of possible start-up of auger, especially if started from another location.
6. **Special enclosures** for motors and controls for hazardous atmospheric conditions.



Figure 2.
Electrical WARNING

DANGER, WARNING and CAUTION Decals

SAFETY information has been provided by the Manufacturer to help insure the safe and proper use of this product. This SAFETY information has been placed on components throughout the structure to provide proper access to the user.

The Decals in **Figures 3, 4, 5, 6 and 7** are located on equipment as shown in the Manual drawings **Figures 8 and 9**. If the DANGER, WARNING and CAUTION Decals are not properly placed or if they are in any way damaged or altered, contact the Manufacturer for immediate replacement.

IMPORTANT!

Check all equipment for WARNING, CAUTION and DANGER Decals and their proper placement BEFORE equipment is operated. NEVER use equipment if Decals are missing, improperly placed, damaged, or altered.

The DANGER Decal 13-27448 in **Figure 3** is located on the SPRING-LOCK® Lid and the ACCESS-PLUS® Auger Boot Bottom Clean-Out Cover on Hopper Bins with Closed-Eave Roofs.



Figure 3.
DANGER Suffocation Decal 13-37448

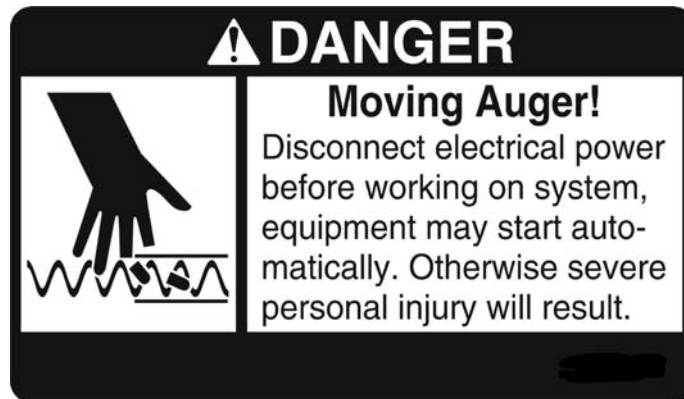

Figure 4.
DANGER/Auger Decal 2527-9



Figure 5.
CAUTION/Guards Decal 13-26115



Figure 6.
DANGER/Auger Decal 13-25805

IMPORTANT! Check all equipment for **DANGER**, **WARNING** and **CAUTION** Decals and their proper placement **BEFORE** equipment is operated. **NEVER** use equipment if Decals are missing, improperly placed, damaged, or altered.

SAFETY

Decal on Hopper Bins with Raised Rib Roofs (Manhole): DANGER of Suffocation/SAFETY Near Moving Equipment

The DANGER Decal (13-26114) in **Figure 7** is located both on the inside and outside of the Manhole Cover (on **Raised Rib Roofs**). It appears in Spanish next to the English Decal. A French language Decal is also available. Other languages may be available upon request.

La calcomanía de ADVERTENCIA (13-26114SP) en la **Figura 7** está ubicada cubiertas interior y exterior de la puerta y en las caras interior y exterior de la escotilla. La calcomanía de ADVERTENCIA aparece en español al lado de la calcomanía de inglés. La calcomanía de ADVERTENCIA también está disponible en la idioma francés. Otras idiomas sería disponible al solicitarla.

L'autocollant DANGER (13-26114FR) sur le **dessin 7** est situé sur l'intérieur et l'extérieur de la poignée. L'autocollant DANGER apparait en espagnol à coté de l'autocollant anglais. Un autocollant en français est également disponible. D'autres traductions seront disponibles selon la demande.

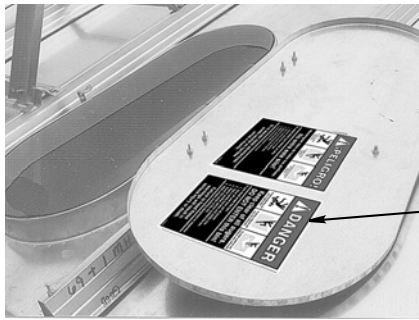

DANGER

<p>Rotating flighting will kill or dismember.</p>	<p>Flowing material will trap and suffocate.</p>	<p>Crusted material will collapse and suffocate.</p>
--	---	---

Keep clear of all augers. DO NOT ENTER this bin!

If you must enter the bin:

1. Shut off and lock out all power.
2. Use a safety harness and safety line.
3. Station another person outside the bin.
4. Avoid the center of the bin.
5. Wear proper breathing equipment or respirator.

Failure to heed these warnings will result in serious injury or death.

13-26114

Figure 7.
DANGER Decal 13-26114

SAFETY 

SAFETY Decal Placement

IMPORTANT!



Check all equipment for **WARNING, DANGER and CAUTION Decals** and their proper placement, **BEFORE** equipment is operated. **NEVER** use equipment if Decals are missing, improperly placed, damaged or altered. Contact your **BROCK Dealer** for replacements.



DANGER Decal (English) 13-26114

This Decal is found inside and outside the Manhole Cover on Hopper Bins with Raised Rib Roofs 12' - 21' [3 658 - 6 401]. It should appear exactly as the Decal on page 10, **Figure 7**.



DANGER Decal (Spanish) 13-26114SP

Located on the inside and outside of the Manhole Cover on Hopper Bins with Raised Rib Roofs 12' - 21' [3 658 - 6 401].

La calcomanía de ADVERTENCIA (13-26114SP) está ubicada cubiertas interior y exterior de la puerta y en las caras interior y exterior de la escotilla. La calcomanía de ADVERTENCIA aparece en español al lado de la calcomanía de inglés. La calcomanía de ADVERTENCIA también está disponible en la idioma francés. Otras idiomas sería disponible al solicitarla.



CAUTION Decal Falling Debris 13-33761

Located on the outside of the ACCESS-PLUS® Door.



CAUTION/GUARDS Decal 13-26115

Should read exactly as the Decal on page 9, **Figure 5**. Located on Belt Guard and Discharge Head.



DANGER/AUGER DECAL 13-25805

Should read exactly as Decal on page 9, **Figure 6**. Located on the Boot Cleanout Cover (solid Auger models) and on the Discharge Head.

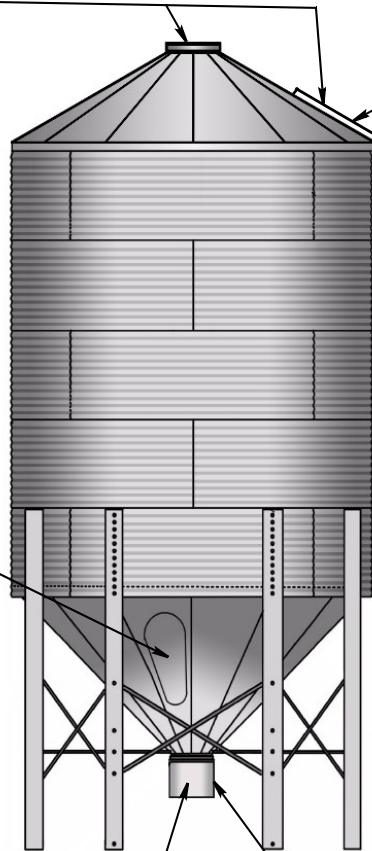

Figure 8.

SAFETY Decal Locations on Hopper Bin with Raised Rib Roof

SAFETY 

DANGER  **Keep clear of all augers. DO NOT ENTER this bin!**



Rotating flighting will kill or dismember. Flowing material will trap and suffocate. Crusted material will collapse and suffocate.

Failure to heed these warnings will result in serious injury or death.

If you must enter the bin:

1. Shut off and lock out all power.
2. Use a safety harness and safety line.
3. Station another person outside the bin.
4. Avoid the center of the bin.
5. Wear proper breathing equipment or respirator.

13-37448

IMPORTANT!

Check all equipment for WARNING, DANGER and CAUTION Decals and their proper placement, BEFORE equipment is operated. NEVER use equipment if Decals are missing, improperly placed, damaged or altered. Contact your BROCK Dealer for replacements.

DANGER Decal 13-37448 (above) and DANGER Decal 13-37448SP (right)
 These Decals are found on either side of the SPRING-LOCK® Lid on Hopper Bin models 6' - 15' [1 829 - 4 572] with Closed Eave Roofs. 13-37448 should read exactly as the Decal on page 9, **Figure 3**. Located in the Lid.

¡PELIGRO!  **Manténgase lejos de todos los sinfines. NO ENTRE este silo!**



El silo en marcha puede matar o desmembrar. El material en flujo le atrapará y sofocará. El material encrustado se quebrará y le sofocará.

Si usted tiene que entrar al silo:

1. Apague y desconecte la energía.
2. Use un harnes y líneas de seguridad.
3. Estacione otra persona afuera del silo.
4. Evite el centro del silo.
5. Utilice equipo de respiración o máscara.

El no atender estas advertencias puede resultar en heridas serias o muerte.

13-37448SP

CAUTION 

GUARDS, ACCESS DOORS, AND COVERS MUST BE SECURELY FASTENED BEFORE OPERATING CONVEYING EQUIPMENT. LOCK OUT POWER BEFORE REMOVING GUARDS, ACCESS DOORS, AND COVERS. FAILURE TO FOLLOW THESE INSTRUCTIONS MAY RESULT IN PERSONAL INJURY OR PROPERTY DAMAGE.

13-26115

CAUTION/Guards Decal 13-26115
 Should read exactly as Decal on page 9, **Figure 5**. Located on the Belt Guard and Discharge Head.

CAUTION 



FALLING DEBRIS

1. Do not remove access panel until bin is empty.
2. Wear proper protective gear (goggles, gloves, etc.) when removing panel and cleaning bin.
3. Do not fit bin until access panel is properly fastened to place.

Failure to heed these warnings could result in personal injury to you or structural damage to the bin.

CAUTION Decal Falling Debris 13-33761
 Located on the outside of the ACCESS-PLUS® Door.

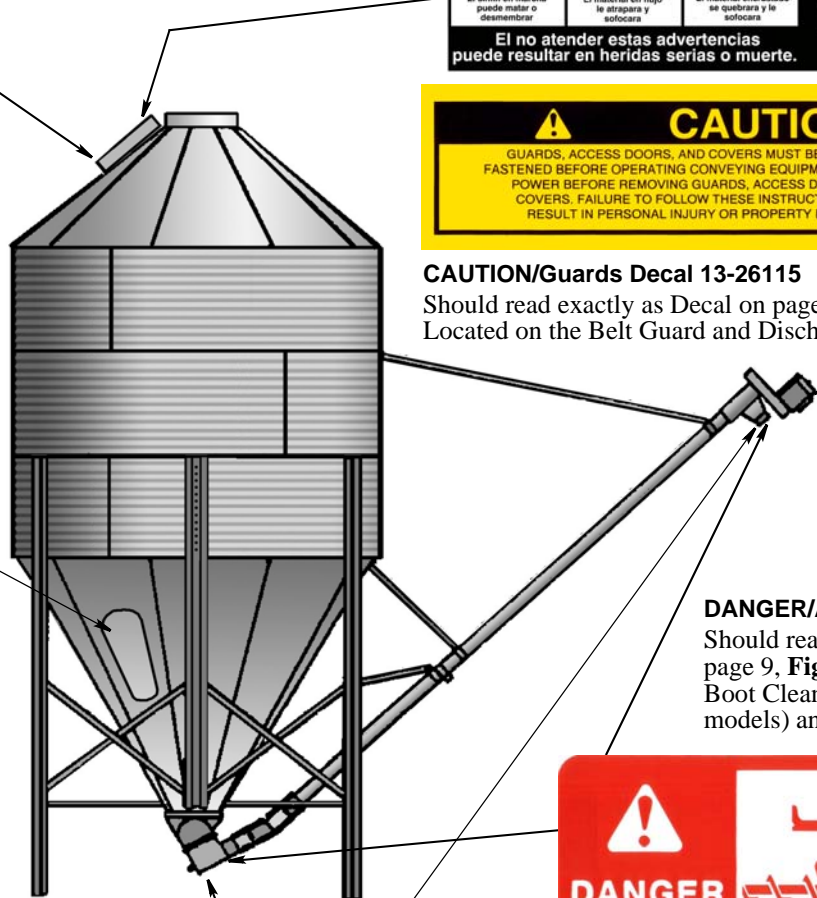

DANGER/Auger Decal 13-25805
 Should read exactly as Decal on page 9, **Figure 6**. Located on the Boot Cleanout Cover (solid Auger models) and on the Discharge Head.

DANGER  

ROTATING FLIGHTING
 THIS EQUIPMENT USES AUGERS WHICH CAN KILL OR DISMEMBER

LOCK OUT POWER BEFORE REMOVING COVER OR GUARD

FAILURE TO DO SO WILL RESULT IN DEATH OR SERIOUS INJURY

13-25805-0286

DANGER 



Moving Auger!
 Disconnect electrical power before working on system, equipment may start automatically. Otherwise severe personal injury will result.

DANGER/Auger Decal 2527-9
 Should read exactly as Decal on page 9, **Figure 4**. Located on the Boot Cleanout Cover (FLEX-AUGER® models) and on the Discharge Head.

Figure 9.

SAFETY Decal Locations on the Hopper Bin with Closed Eave Roof

SAFETY 

DANGER!



There are Suffocation Hazards in Flowing Grain

Never enter a Grain Bin of flowing feed, grain, or other material. Failure to follow these instructions will result in death or serious injury.

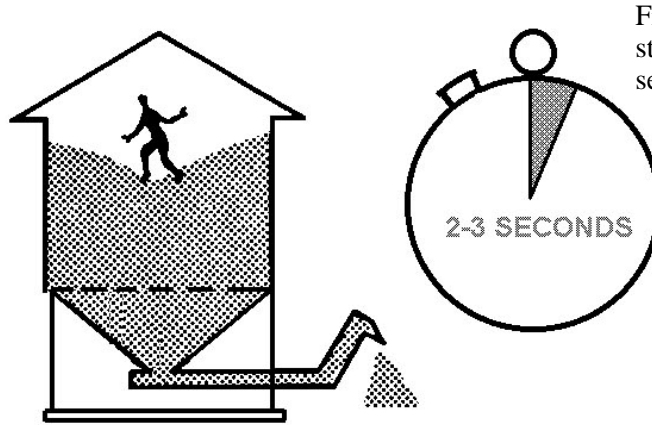

From the time the auger starts, you have 2-3 seconds to react.

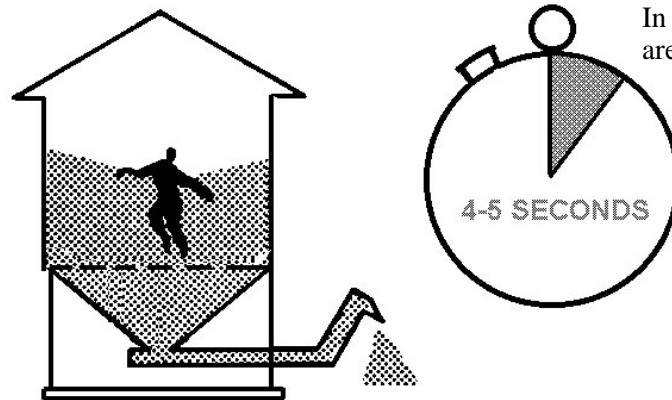

In 4-5 seconds you are trapped.

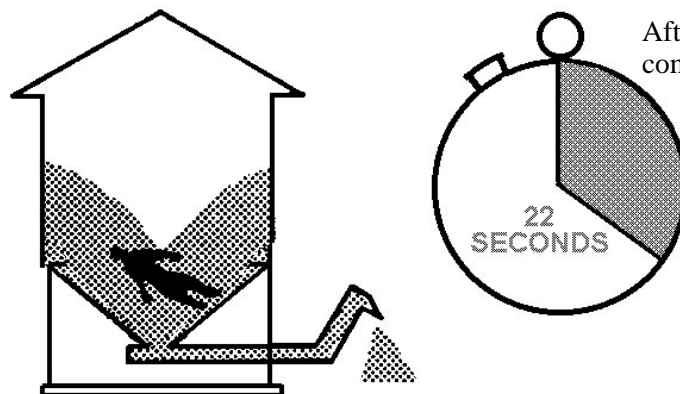

After 22 seconds, you are completely covered.

Figure 10.
Suffocation Hazards in Flowing Grain

SAFETY



Safety Hazards and Recommendations

Twelve Points That Could Save Your Life

Remember to always follow national and locally developed guidelines (OSHA in the U.S.) and applicable sections—at least those listed—for safe grain system operation.

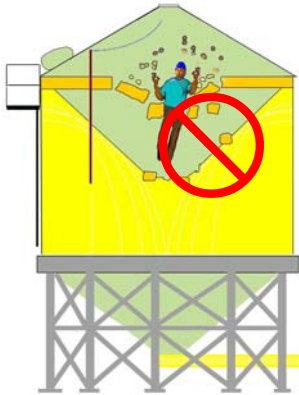

Figure 10a.
Grain Crusting
and Bridging

1. **Never enter a bin of flowing grain**—when loading or unloading equipment is running, whether or not grain is flowing or stopped; you can be engulfed if and when the flow resumes. See **Figure 10**, page 13. Moving grain creates a suction that can pull a worker in within seconds. Never enter a bin that has automatic unloading equipment **without locking out the control panel/circuit and any other power that may start the equipment**.
2. Always be cautious when you are working with grain that is **not in good condition**.
3. Never enter a bin that you do not know the nature of previous grain removal, especially if there is any vertical or horizontal **crusting or bridging** evident. See **Figure 10a**, left. There may be blocked flow, toxic molds, empty cavities, cave-offs, or any combination of the above—which can lead to entrapment/engulfment and suffocation.
4. Prohibit entry into and **do not walk on any surface crust** where there is horizontal bridging. Prohibit entry into and **do not walk near any surface crust** where there is vertical bridging.
5. If you are properly trained and qualified to do so and must enter a bin with evident danger, follow all national, state and local safety codes for bin entry. Complete and verify that all **safety steps required for a Bin Entry Permit** have been followed.
6. Be sure that **rescue equipment**, such as winch systems, are provided and working.
7. **Test the air** for the presence of sufficient oxygen and/or combustible and toxic gases. Provide and continue ventilation until any unsafe atmospheric conditions are eliminated.
8. The bin entrant must be provided with and must be fastened to a **safety harness-lifeline** or boatswain's chair secured and monitored by two attendants outside (Point 10). The lifeline should be a proper length to prevent the entrant from sinking into grain further than waist-deep.
9. Before entering a grain bin, **de-energize and turn off, LOCK OUT and TAGOUT** all mechanical, electrical, hydraulic and pneumatic equipment that presents a danger, especially unloading equipment, which will cause a worker to be pulled into the grain in seconds.
10. Provide *per entrant* a minimum of two (2) **properly equipped attendants** stationed outside the bin, whose only task is to continuously track and communicate with the entrant in the bin, to provide assistance if necessary, and to be capable of lifting the entrant out without entering the bin themselves. **Never depend** on one (1) attendant only, either on the roof, ground, or any other remote point to whom you would shout instructions *to start or stop equipment*. (Equipment noise or other sounds can block out commands or cries for help.) A single attendant cannot go for help **and** maintain preliminary aid outside, and may fall or over-exert in the haste of running to the control point.
11. The bin entrant must be provided with a proper mask or an **adequate dust-filtering respirator** when working in and around grain handling areas. High amounts of dust and molds could be present and are extremely dangerous. Never work in obviously dusty-moldy grain, or where the presence of CO₂ is suspected, without a respirator capable of filtering fine dust. Be aware that your tolerance to a given material may be limited, and that you should not deliberately expose yourself to grain dust on the premise that you will not be affected at any time.
12. **If another person becomes submerged in grain**, assume he is alive. Begin rescue operations immediately by turning OFF the unloading equipment if not already locked out, and turning ON the fan to move air into the bin, but: **never attempt a rescue by going into the bin yourself. Call 911.** Always have a rescue plan and be prepared for grain facility emergencies by working early with your local emergency team to get training and equipment to do the job safely.

Act responsibly NOW to reduce the risk of Emergency.

Be sure to advise your children, your co-workers, and your neighbors about this SAFETY information.

SAFETY

Employers must act responsibly now to reduce the risk of emergency!

Before it is too late: Talk to your children, co-workers, and your neighbors about the SAFETY information in this Manual. Many lives depend on it.

Your attention to SAFETY will impact:

- You and your family
- Your employees
- Your neighbors and community
- Your subcontractors
- Your customers and future customers
- The grain bin industry as a whole

Prohibit “walking down” grain, or similar practices, to make it flow.

- Label grain bins to warn of entrapment hazards.
- Lock entrances to grain handling areas to keep bystanders and children out.

Considerations that may result in a hazard, damage your Bin and/or void your Warranty

BROCK® Grain Bins are offered in several models for specific uses. In order to maintain your bin and its Warranty, the appropriate type bin must be used. Consult BROCK Grain Systems or your BROCK Dealer.

Read and understand this Construction Manual, your Owner/Operator’s Manual and all SAFETY Decals.

Damage to a Grain Bin can occur due to improper **construction** of the Grain Bin. Therefore:

1. Use **all hardware specified** in the instructions and make no substitutions.
2. Refer to pages 16-20 in this Manual for proper Foundation specifications. Cracks in the foundation are a danger signal. It is suggested that if cracks are present they be monitored for any changes, and remedial action taken.
3. Grain Bin foundations must be **level**.
4. If you have chosen a Raised Rib roof, with this Manual you will also have a Roof Manual **Supplement: BROCK® 12' - 48' [3 658 - 14 630] Roof Instruction** (Manual No. MGB1496).

Cables to support conveying equipment such as bucket elevators or conveyor legs must not be attached to the Grain Bin roof or sidewalls. To do so will cause damage to the Grain Bin. Refer to your Roof Manual for construction of proper supports for such equipment.

CAUTION!



Additional loads on Grain Bin sidewalls, roofs and hoppers can be created by improper drying methods.

Grain Bin damage can also occur due to improper **ventilation, loading and unloading** of the Grain Bin:

1. When the Grain Bin is filled off-center.
2. When unloading is done from off-center. Uneven wall pressures may occur, allowing the wall to flatten directly nearest the unloading point, and damage can be seen above and several feet to either side of this area. Severe sheet seam damage can occur, causing significant or complete Grain Bin damage. Internal pressures change when only a few bushels of grain or feed have been removed. Damage can be caused by incorrectly unloading even small amounts of material.

Foundations



FOUNDATIONS shall be placed on undisturbed soil or engineered backfill with bearing capacity of at least 3000 pounds per square foot [14 647 kg/m] or special modification of foundations must be considered. If questions arise, contact a qualified soil engineer.

FOUNDATIONS shall be appropriately designed for local soil and frost depth conditions. Sizes given are adequate for resisting 1.5 times the overturning force of a 90 mph [145 km/h] wind and seismic zone 1.

FOUNDATIONS should be smooth and level to within 1/4" [6.4].

CONCRETE IN FOOTINGS shall have a minimum compressive strength, $f_c' = 3000$ psi (pounds per square inch) [20 684 kPa] at 28 days.

CONCRETE REINFORCING STEEL shall have a minimum yield strength of 33,000 psi [227 527 kPa].

Concrete should be cured seven days before building bin and 28 days before filling the Grain Bin.

Anchoring

A 5/8" x 8" x 2" Anchor Rod (Part No. 39-20075)* is available from Brock Grain Systems. Anchors must be embedded 6 1/2" [165].

* 12' [3 658] 60° 11-ring bins use 5/8 x 12" Heavy Hex Head Bolt, embedded 10" [254], with Heavy Nut and Octagon Washer. These are included in the parts kit.



CAUTION! *Measure between opposite and adjacent Anchors to be sure they are an equal distance apart before securing. Failure to do so may cause damage to the Bin.*

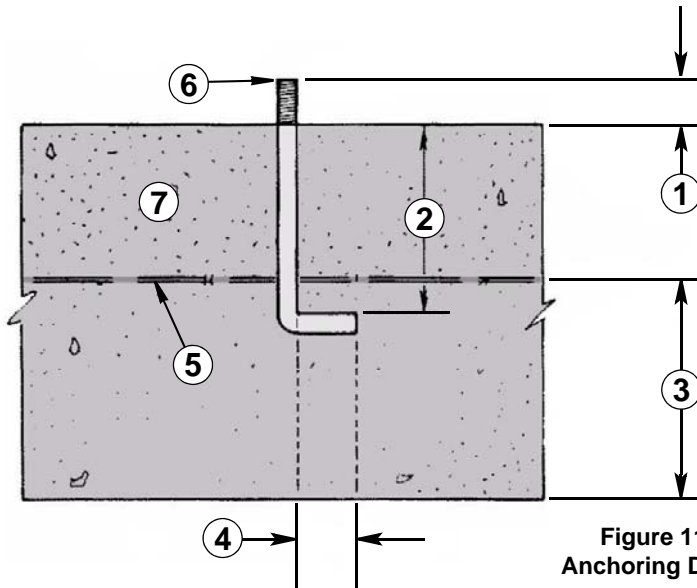

Item	Description
1	1 1/2" [38]
2	6 1/2" [165]
3	WWF must be at or above mid-depth of slab.
4	2" [51]
5	6 x 6 - W1.4xW1.4 Welded Wire Fabric [152x152 - MW9xMW9]
6	Anchor Rod
7	Concrete

Figure 11. Anchoring Detail

Alternate Anchoring

Install Anchor Rods before setting bin to insure proper location.

- 1) A 5/8 x 9" Heavy Hex Gr. 2 Bolt embedded to a depth of 7" [178].

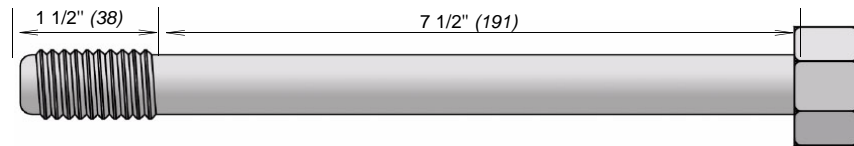

Figure 11.
5/8 x 9" Heavy Hex Gr. 2 Bolt

- 2) HILTI® Kwik-Bolt 3 Expansion Anchor, 3/4 x 7" or equivalent. Each Anchor must have a minimum embedment of 5" [127].

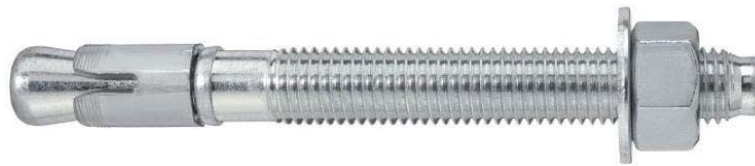

Figure 12.
Hilti® Kwik Bolt 3 Carbon Steel Expansion Anchor

- 3) HILTI® HAS-E Anchor Rod, 5/8" x 8" or equivalent. Each Anchor must have a minimum embedment of 6" [152].



Figure 13.
Hilti® HAS-E Anchor Rod and HVU Adhesive

CAUTION!



Lay out locations and install anchors before setting the bin to insure proper location. Failure to do so may cause damage to the bin.

Do NOT use Legs as a template to drill, because the bin may not be round.

Specifications

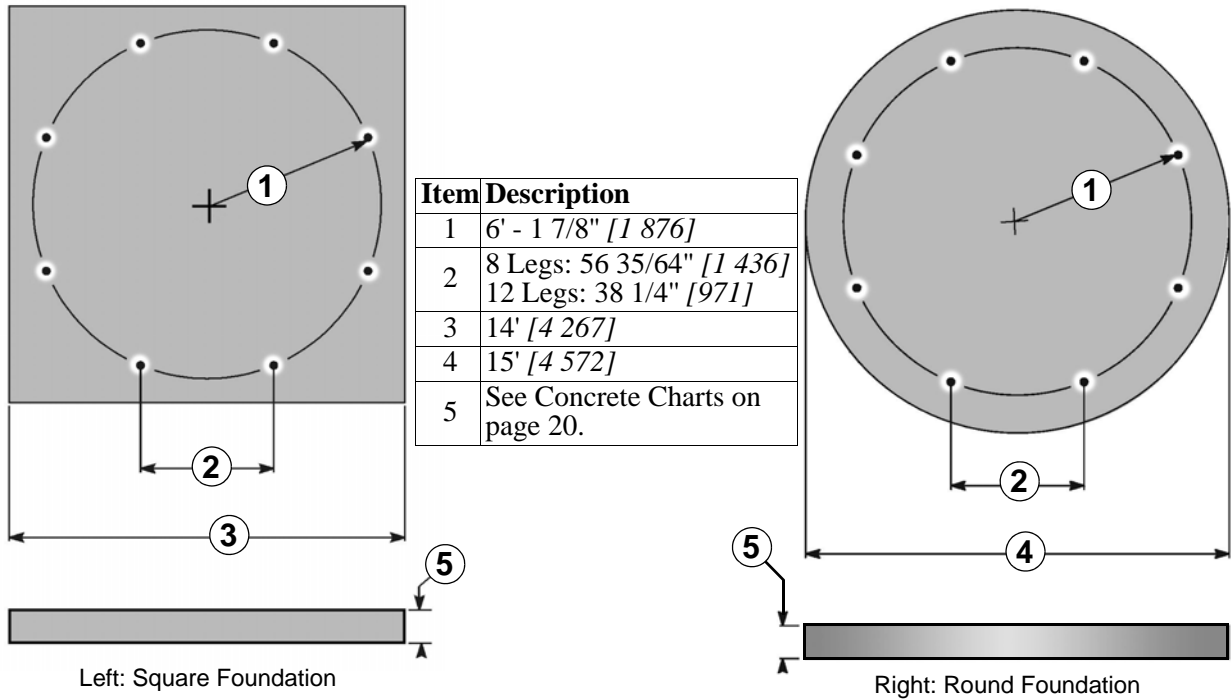
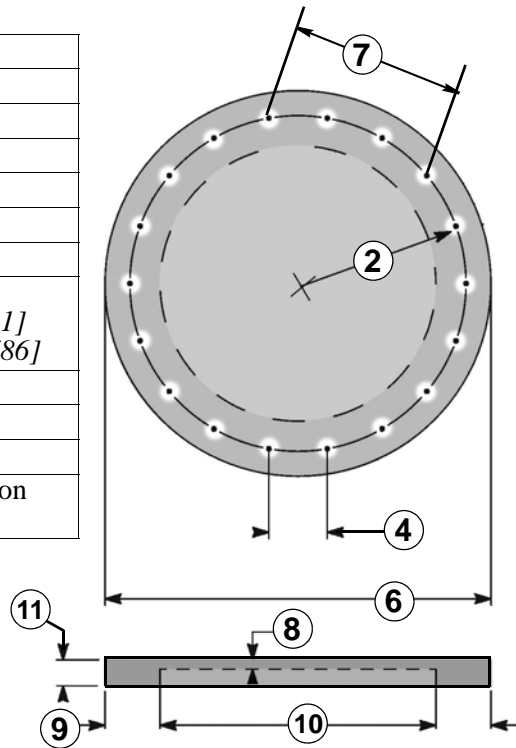
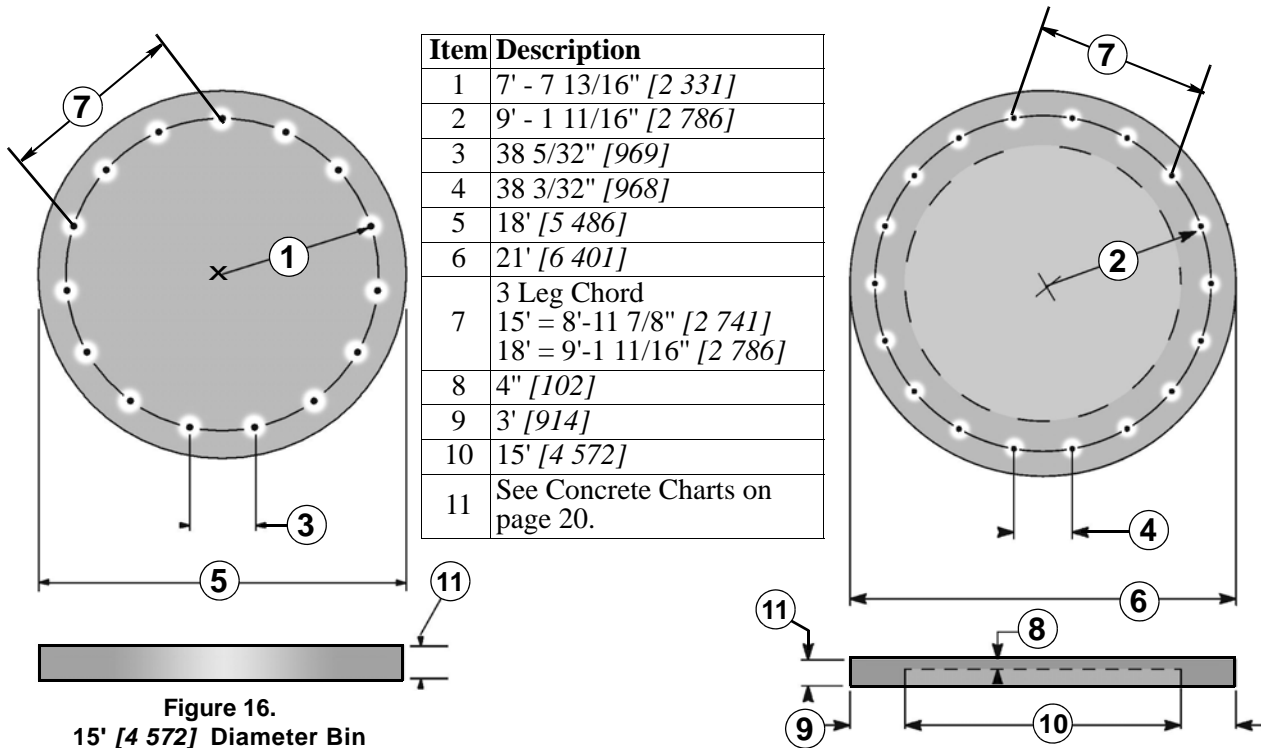

Figure 15.
12' [3 658] Diameter Bin



Item	Description
1	10'-7 5/8" [3 242]
2	38 1/32" [966]
3	24' [7 315]
4	4" [102]
5	3' [914]
6	18' [5 486]
7	3-Leg Chord: 9' - 2 3/4" [2 813]
8	See Concrete Charts on page 20.

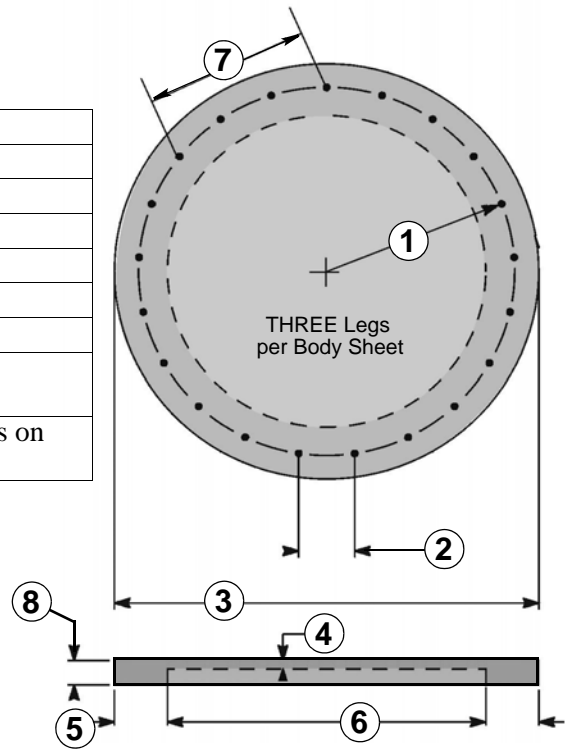

Figure 18.
21' [6 401] Diameter Bin
Three Legs per Body Sheet (2-6 Rings)

Item	Description
1	10' - 7 5/8" [3 242]
2	28 9/16" [725]
3	24' [7 315]
4	4" [102]
5	3' [914]
6	18' [5 486]
7	4-Leg Chord: 9' - 2 3/4" [2 813]
8	See Concrete Charts on page 20.

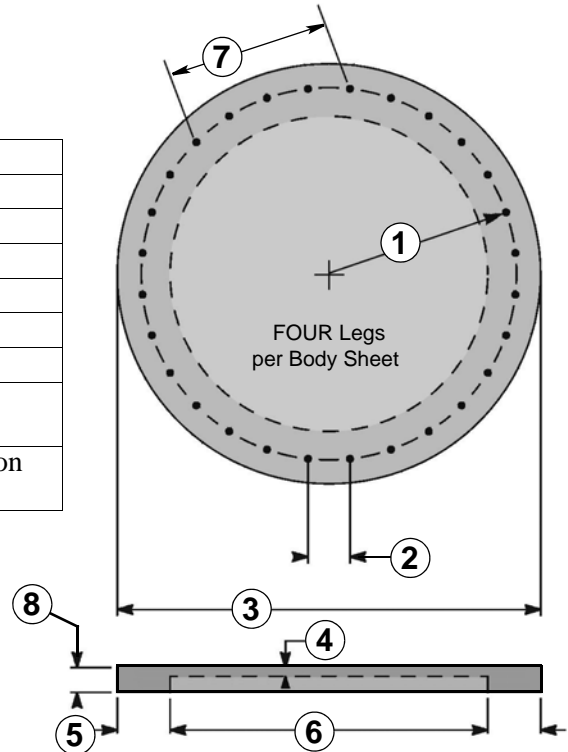

Figure 19.
21' [6 401] Diameter Bin
Four Legs per Body Sheet (7-8 Rings)

Concrete Charts

SQUARE FOOTER Concrete Specs (English)			SQUARE FOOTER Concrete Specs (Metric)		
Model Found. Size	12' Dia. Bin 14' X 14' (Figure 14)		Model Found. Size	12' Dia. Bin 4 267 x 4 267mm (Figure 14)	
Rings	Thickness (inches)	Volume (cu. yds.)	Rings	Thickness [mm]	Volume [cu. m]
1	9"	5.4	1	229	4.2
2	9"	5.4	2	229	4.2
3	10"	6.0	3	254	4.6
4	11"	6.7	4	279	5.1
5	11"	6.7	5	279	5.1
6	12"	7.3	6	305	5.6
7	12"	7.3	7	305	5.6
8	13"	7.9	8	330	6.0
9	14"	8.5	9	356	6.5
10	14"	8.5	10	356	6.5
11	16"	9.7	11	406	7.4

ROUND Footer Concrete Specs (English)										
Model Found. Size	12' Dia. Bin 15' Dia. (Figure 15)		15' Dia. Bin 18' Dia. (Figure 16)		18' Dia. Bin 21' Outside Dia. 15' Inside Dia. (Figure 17)			21' Dia. Bin 24' Outside Dia. 18' Inside Dia. (Fig. 18-19)		
Rings	Thickness (inches)	Volume (cu. yds.)	Thickness (inches)	Volume (cu. yds.)	Outside Thickness (inches)	Inside Thickness (inches)	Volume (cu. yds.)	Outside Thickness (inches)	Inside Thickness (inches)	Volume (cu. yds.)
1	9"	4.9								
2	10"	5.5	10"	7.9	10"	4"	7.4	11"	4"	9.9
3	11"	6.0	10"	7.9	11"	4"	7.9	11"	4"	9.9
4	12"	6.5	11"	8.6	11"	4"	7.9	12"	4"	10.5
5	12"	6.5	11"	8.6	12"	4"	8.5	13"	4"	11.1
6	13"	7.1	12"	9.4	12"	4"	8.5	13"	4"	11.1
7	14"	7.6	12"	9.4	13"	4"	9.0	14"	4"	11.7
8	14"	7.6	13"	10.2	14"	4"	9.5	15"	4"	12.3
9	14"	7.6	13"	10.2	14"	4"	9.5			
10	14"	7.6								
11	16"	8.7								

ROUND Footer Concrete Specs [Metric]										
Model Found. Size	3 658 Dia. Bin 4 572 Dia.		4 572 Dia. Bin 5 486 Dia.		5 486 Dia. Bin 6 401 Outside Dia. 4 572 Inside Dia.			6 401 Dia. Bin 7 315 Outside Dia. 5 486 Inside Dia.		
Rings	Thickness [mm]	Volume [cu. m]	Thickness [mm]	Volume [cu. m]	Outside Thickness [mm]	Inside Thickness [mm]	Volume [cu. m]	Outside Thickness [mm]	Inside Thickness [mm]	Volume [cu. m]
1	229	3.8								
2	254	4.2	254	6.0	254	102	5.7	279	102	7.6
3	279	4.6	254	6.0	279	102	6.1	279	102	7.6
4	305	5.0	279	6.6	279	102	6.1	305	102	8.0
5	305	5.0	279	6.6	305	102	6.5	330	102	8.5
6	330	5.4	305	7.2	305	102	6.5	330	102	8.5
7	356	5.8	305	7.2	330	102	6.9	356	102	8.9
8	356	5.8	330	7.8	356	102	7.3	381	102	9.4
9	356	5.8	330	7.8	356	102	7.3			
10	356	5.8								
11	406	6.7								

Body Sheet Assembly

Body Sheet Identification

On the corner of each Sheet is a colored Sticker with the Part Number, gauge and diameter printed on it. This is helpful in locating each sheet on the Specifications and Parts Lists.

Body Sheets are also identified with paint on an edge near the end. The first color nearest the end will indicate gauge and corresponds with the gauge and color chart below. Black paint next will indicate a sheet with a sign.

Body Sheet Gauges

Gauge	Thickness		Color
	inches	mm	
20	.035	[.88]	white
19	.040	[1.02]	brown
18	.046	[1.18]	pink
17	.053	[1.34]	yellow
16	.058	[1.47]	orange
15	.065	[1.66]	light blue
14	.072	[1.82]	dark green
13	.088	[2.25]	gray
12	.102	[2.59]	dark blue
11	.118	[2.99]	light green
10	.136	[3.45]	black
9	.150	[3.80]	copper
8	.165	[4.20]	silver

Caulking (Sealant) Is Critical!

Wipe the Sheets clean where the Caulking is to be applied. All Collar, Body, Hopper and Roof seams (except Raised Rib Roofs) are caulked with a bead of Caulking on each side of the line of holes. Take notice of the **Critical Caulking Points** in **Figure 20** and be sure to follow Caulking instructions carefully.

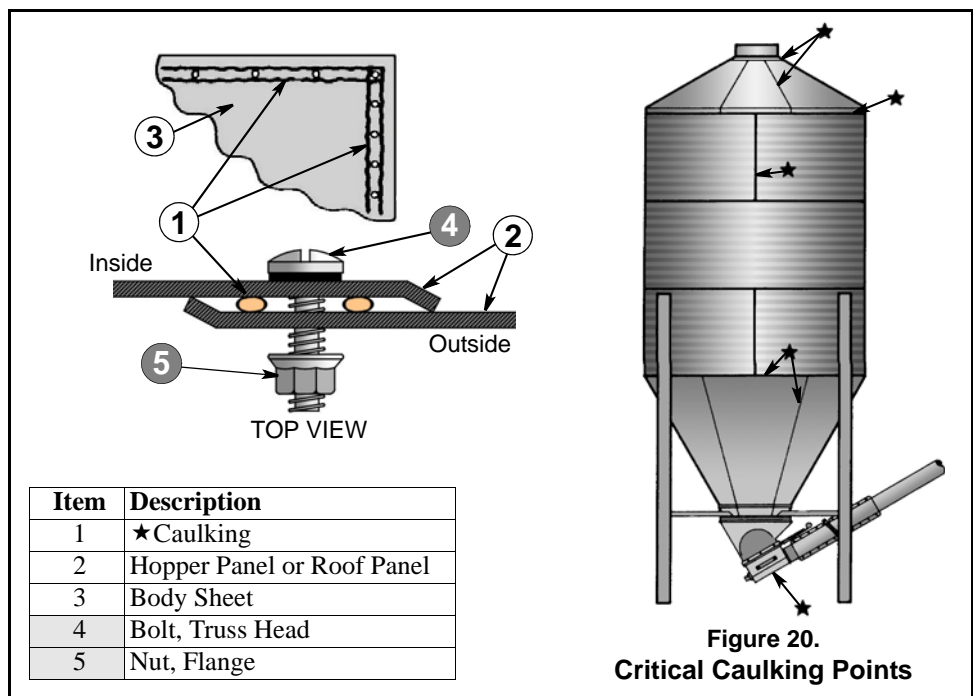

Hardware Connections

All body and roof seams use 5/16 x 1" Grade 8.2 Hex Head Bin Seal Bolts and Hex Nuts, or the optional Plastic Head Bolts, with the heads on the **outside** of the bin.

All **Leg-to-Body** Bolts have the heads on the **inside** of the Bin.

All **Hopper Collars** use 5/16" dia. Truss Head Bin Seal Gr. 8.2 Bolts (lengths vary) and Flange Nuts with the heads on the **inside** of the bin.

All 12' [3 658] and 15' [4 572] Hopper **seams** use 5/16" dia. Truss Head Bin Seal Gr. 8.2 Bolts (lengths vary) and Flange Nuts with heads **inside** the bin.

All 18' [5 486] and 21' [6 401] Hopper **seams** use 3/8" dia. Truss Head Bin Seal Gr. 8.2 Bolts (lengths vary) and Flange Nuts with heads **inside** the bin.

Plastic Head Bolts are **not** used on Hopper vertical seams.

Grade 8.2 Hex Head Bolts are identified with markings such as in **Figure 1**.

A 3/8" Grade 8.2 Bin Seal Bolt has an approximate safe load of 2650 pounds [1 202 kg].

A 5/16" Grade 8.2 Bin Seal Bolt has an approximate safe load of 1840 pounds [835 kg].

Keep this in mind for the number of bolts needed to lift bins during assembly.

Tighten 5/16" Nuts to 15-20 ft-lb [20-27 N-m] of torque.

Tighten 3/8" Nuts to 25-30 ft-lb [34-41 N-m] of torque.

Overview

All Body Rings must be assembled with the vertical seams **staggered**.

12' [3 658] diameter bins use 4 Sheets per ring.

15' [4 572] diameter bins use 5 Sheets per ring.

18' [5 486] diameter bins use 6 Sheets per ring.

21' [6 401] diameter bins use 7 Sheets per ring.

The Leg holes must be in **alignment** in the bottom two Rings.

Bolts are always tightened from the **Nut** side to prevent damage to the seals.

A drift punch should be used to align holes. 5/16 x 1" Grade 8.2 Hex Head Bin Seal Bolts are used on all vertical and horizontal body sheet seams with bolt heads on the **outside**. Note exception where Legs are attached. Bolt the Body Sheets end-to-end, overlapping the same direction throughout the bin. Finger-tighten the Bolts only until the next ring has been added.

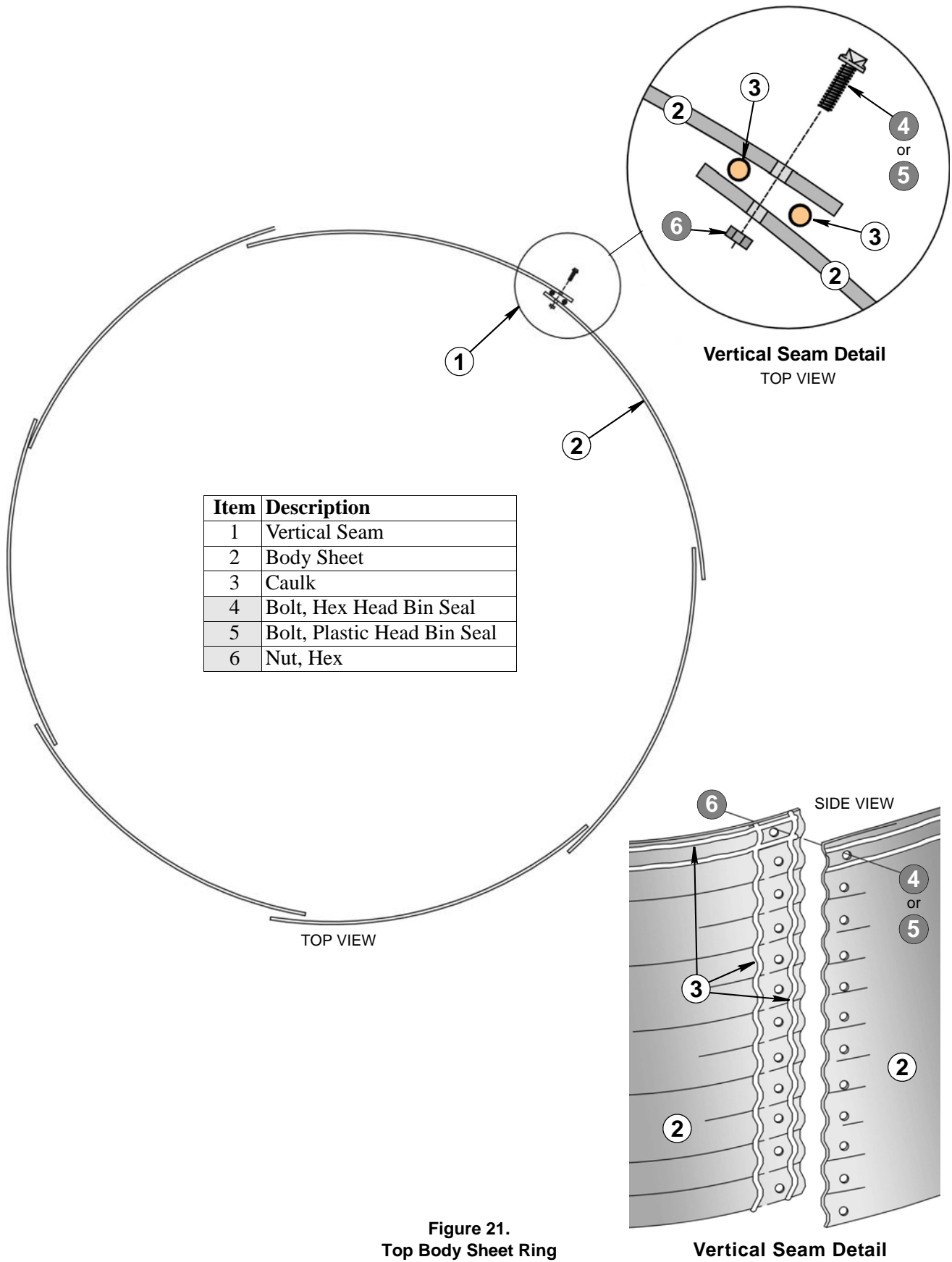

Figure 21.
Top Body Sheet Ring

Vertical Seam Detail

Hopper Bin Roof (Closed Eave)



Roof construction varies according to bin diameter and type of Roof chosen, either a Raised Rib or Closed Eave.

LARGER diameter Hopper Bins 18' - 21' [5 486 - 6 401] have RAISED RIB ROOFS. If your Hopper Bin has a Raised Rib Roof, refer to the the Roof Manual Supplement to this Base Manual: MGB1496, BROCK Roof Construction Manual. When your Roof is complete, return to the next section in this Manual entitled "Lifting the Tank" and continue building your Hopper Bin.

Planning the Roof

IMPORTANT!

The roof must be started correctly for the Shur-Lock® Lid Opener to work properly. Refer to BROCK® Manual MHB1183, "Shur-Lock Lid Operator Installation Instructions."

The Fillhole Lid should open about 90° from the Roof Ladder. The Lid Opener must be centered over a Roof Panel and centered over the Leg where the Lid Opener Handle attaches.

If using an air fill system, plan for that as you build the Hopper Bin roof.

Determine the location of the first Roof Panel. Refer to the Roof Ladder Instructions packaged with the Ladder.

The Roof Ladder should be **centered** over a Roof Panel and directly **above** the Side Ladder. Be sure the location of the Roof Ladder will not put the side Ladder in the way of other equipment.

The Closed Eave Roof **Ladder** is attached **as** the Roof Panels are assembled. At the eave it connects to the Side Ladder with a **Bottom Ladder Corner**. **You must refer to Ladder instructions for Closed Eave Roofs in the Hopper Bin Ladder, Cage, and Platform Manual MHB1370** for Part Numbers and assembly.

IMPORTANT!

The Roof Ladder is centered over a Roof Panel but will not be centered between Legs. Be sure the location of the Roof Ladder will not put the Side Ladder in the way of other equipment. See Figure 22.

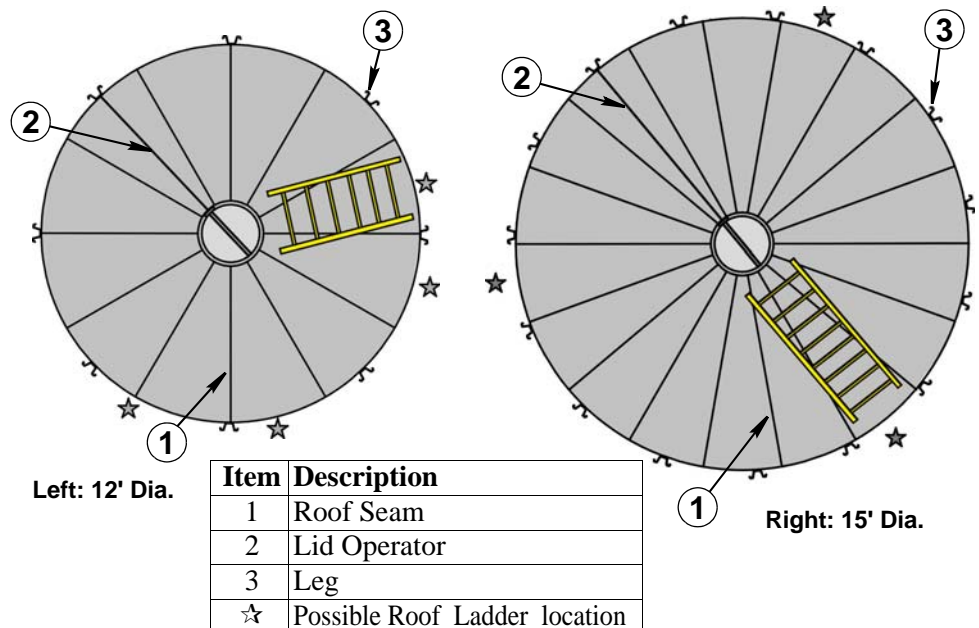

Figure 22.
Possible Roof Ladder Locations

Roof Panels

Install Roof Panels, wiping them first, overlapping with the crimped edge break **down** on the **outside** of the top ring of Body Sheets.

Item	Description
1	Roof Panel
2	Top Body Sheet

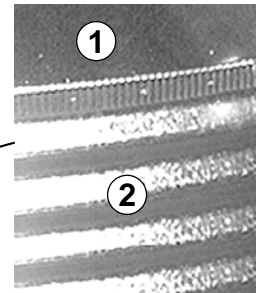
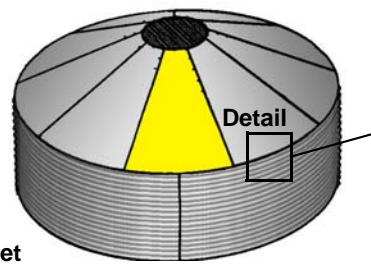
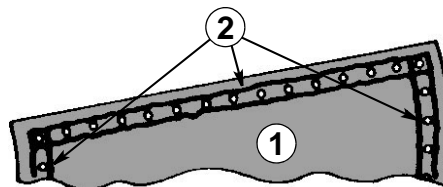

Figure 23.
Roof Panel to Top Body Sheet

The **Closed Eave Roof** requires caulking on **all** seams of the Roof Panels. Caulk on **both** sides of the holes.



Item	Description
1	Roof Panel
2	Caulking

Figure 24.
Roof Panel Caulking

Roof Reinforcement Angles

On the 12' Bin with the **30°** Closed Eave Roof, Roof Reinforcement Angle (3-16402) are used on **each side** of the Roof Ladder.

On the 12' Bin with the **40°** Closed Eave Roof, Roof Reinforcement Angles (3-3417) are used on **each side** of the Roof Ladder.

On the 15' [4 572] Bin with the **30°** Closed Eave Roof, a Roof Reinforcement Angle (3-13880) must be placed under every **third** roof seam as well as two under the Ladder. These are shipped with the Bin as a Roof Reinforcement Bundle (3-24146).

On the 15' [4 572] Bin with the **40°** Closed Eave Roof, a Roof Reinforcement Angle (3-33418) must be placed under **every** roof seam. These are shipped with the Bin as a Roof Reinforcement Bundle (3-33424).

Roof Reinforcement Angles may be with the Roof Ladder.

Item	Description
1	Caulking
2	Roof Panel
3	Roof Reinforcement Angle
4	Nut, Hex 5/16"-18
5	Bolt, Bin Seal 5/16-18 x 1" Gr. 8.2

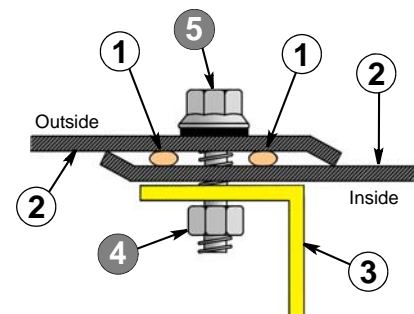

Figure 25.
Roof Reinforcement Angle

IMPORTANT! *Roof Reinforcement Angles must be installed tightly under Roof Panel seams under the Roof Ladder.*

Fillhole and Lid

Install the **Fillhole** on the **outside** of the Roof Panels. Use enough Caulking around the Fillhole to ensure a tight seal.

Lid instructions for each Lid option are packaged in the Lid box.

Hopper Bin Roof (Raised Rib) and Tank Lifting

Lifting and Assembling the Tank

When the Roof and top ring of Body Sheets are completed, attach **lifting brackets** (not supplied) on vertical seams. Four 5/16 x 1" Grade 8.2 Bolts per lifting bracket are the minimum recommended. At least **one** jack for every other seam is required (**every** seam is best).



Choosing the Proper Jacks to Lift the Tank

Jacks are used to lift the bin slowly and evenly during assembly of the wall sheets. The jack shown in **Figure 28** is only a representation. Jacks should be designed using accepted engineering practices, taking into account the dead and live loads associated with construction. **Jacks should be capable of sufficient lift to allow assembly of two Rings per setting. Determine the number of jacks required for the weight of the tank** and attach lifting brackets to the Body Sheets at Stiffeners. Bolts must be adequate for lifting the load.

IMPORTANT!

The jack represented in Figure 28 is not adequate for all sizes of bins. On larger bins, electric or hydraulic jacks are recommended. Consult the jack manufacturer for instructions.

Jacks must be able to hold **twice the weight** of the bin. Size and placement of jacks must be calculated based on the total dead and live load of the completed bin. Jacks should not be positioned more than **two** Body Sheet lengths apart, or about 18' 9" [5 715]. At least one jack for every **other** seam is required (every seam is best). **Cables** may be needed to steady the bin during construction.

CAUTION!



Do not jack the tank under windy conditions! This could result in tank damage.

SAFETY Procedures While Lifting the Tank

1. Be sure Jacks and cables are anchored securely.
2. **Verify locations** of Roof Manhole (Raised Rib only), Ladders, and Access Door before starting to raise the bin.
3. When lifting with jacks, raise the Tank **just enough** to add **one** new Ring of Body Sheets. (Caulk horizontal and vertical seams.)
4. Start assembly of each new Ring of Body Sheets on the **windward side** of the Tank.
5. Leave all bolts **loose** in the new Ring until all Sheets have been attached.
6. Attach **Ladders, Cages, and Platforms** as you assemble the Body Sheets.
7. Repeat Steps 3 - 4 as new Rings are being added.
8. Install the Hopper, Legs, and Bracing.
9. Lower the tank and secure it to the foundation **before the leaving the job site**.
10. **Follow** the jack manufacturer's recommendations for capacity and operations.

Item	Description
1	Existing Ring
2	New Ring below
3	Windward Side

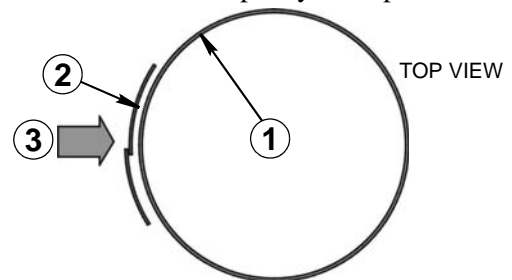

Figure 26.
Rings on Windward Side

IMPORTANT! *Read carefully and follow the lifting instructions particular to your diameter Bin.*

CAUTION! *Improper design or use of jacks may result in damage to the bin and/or personal injury.*

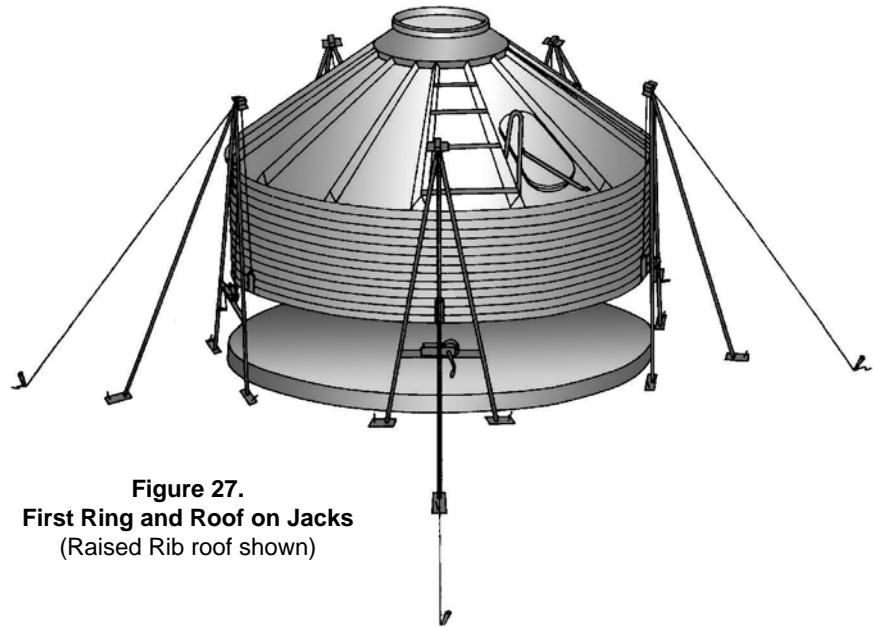

Figure 27.
First Ring and Roof on Jacks
(Raised Rib roof shown)

Item	Description
1	Pulley
2	Lift Bracket
3	Hand Winch
4	Concrete Anchors recommended
5	Base (must rest on concrete)
6	Stake
7	Stabilizers

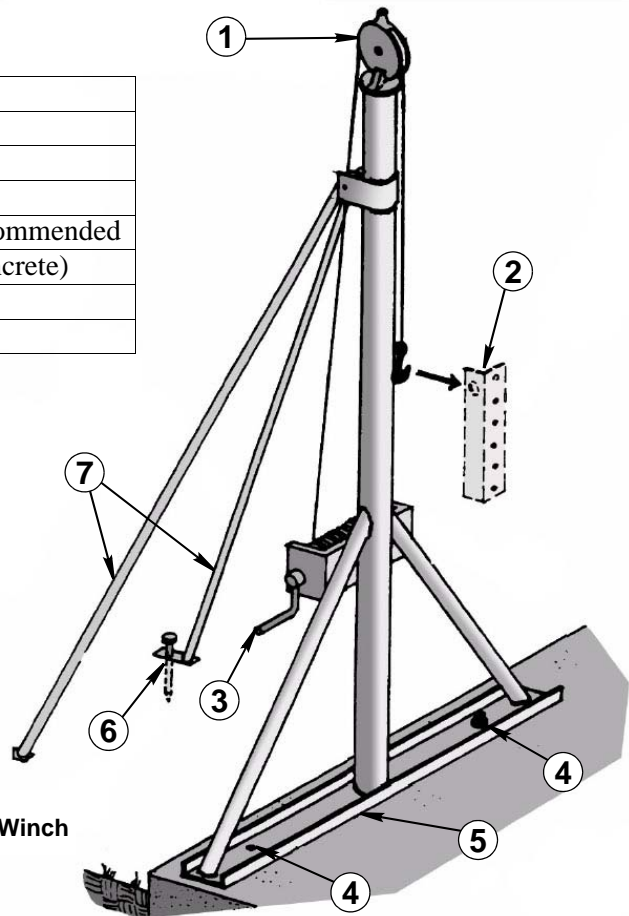

Figure 28.
Jack with Pulley and Hand Winch

Adding Body Sheet Rings

Remember to stagger the vertical seams so they are placed in the center of the Sheet above, except Leg Sheets on bins with three Legs per Body Sheet.

IMPORTANT! *Leg holes must be in alignment.*

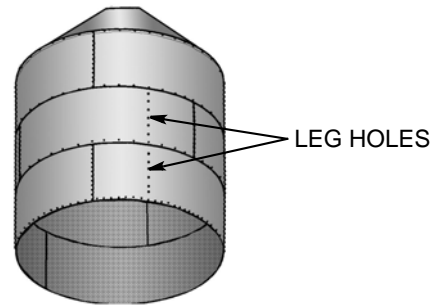

Figure 29.
Stagger Seams and Align Leg Holes

The horizontal seam of the Body Sheet on the ring above should overlap the ring below it. Tighten Bolts in the horizontal seams from the **center** of the sheet **out** to the ends. Caulk horizontal and vertical seams as shown in **Figure 20**.

As you add Body Rings, refer to Body Sheet Identification Charts for correct sheet locations and Bolt specifications. As each ring is added, **tighten** the Bolts in the ring above.

Leg-to-Hopper Attachment

After all Body Sheets are installed and tightened, raise the bin and attach the Legs. Bolt the Legs to the Bin with the bolt heads **inside** as shown in **Figure 30**. **Use only the bottom 22 holes in the Body Sheets. Do not put a bolt in the next-to-bottom hole yet, as the Hopper attaches in this hole.**

A Curved Washer (Item 7) is required on 60-degree Hoppers.

When more than 30" [762] clearance under the Collar is required, contact the Manufacturer for Leg extension and bracing requirements.

Item	Description
1	Body Sheet
2	Hopper Panel
3	Leg
4	Caulking
5	Bolt, Bin Seal 5/16-18 x 1" Gr. 8.2
6	Nut, Flange 5/16"-18
7	Washer, Curved 12 ga. (39-20074) 60° Hoppers only

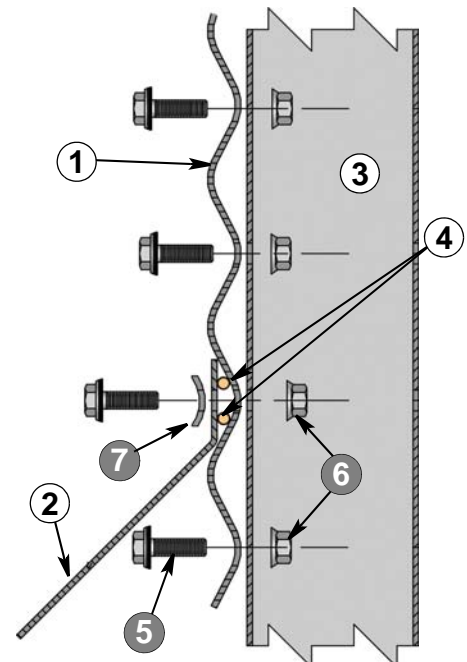

Figure 30.
Installing Legs to Hopper

Hopper Assembly

Hopper Panels

With the Legs on and the Bolts tightened, release the jack tension just enough to rest the bin on the Legs.

Next install the Hopper Panels, starting vertical seams **exactly halfway** between the Leg bolt holes. Refer to **Figures 40-45** for further instructions on the particular size bin you are building.



Remember the Hopper Collar must be installed **before** the last Hopper Panel is put on. Don't forget the bottom Ladder Brackets. Side Ladder Sections should be added as the Body Sections are installed. (See your *Hopper Bin Ladder, Cage, and Platform Manual Supplement MHB1370.*)

Determine which way the DANGER Decal should face in relation to the direction of the Auger.

Wipe the **inside** of the bottom ring where the Hopper attaches (second corrugation up from bottom) and caulk along both sides of the holes.

Wipe and caulk the Hopper and Collar seams on both sides of the holes. See **Figure 31.**

IMPORTANT! *5/16" Truss Head Bolts and Flange Nuts (lengths vary) are used on 12' [3 658] and 15' [4 572] bins.*

3/8" Truss Head Bolts and Flange Nuts (lengths vary) are used on 18' [5 486] and 21' [6 401] bins.

Start the first Hopper Panel seam exactly midway between the set of Legs where the Auger will exit.

Overlap vertical Hopper seams so the left formed edge is on top and traps the Caulking. Assemble all but one of the Hopper Panels.

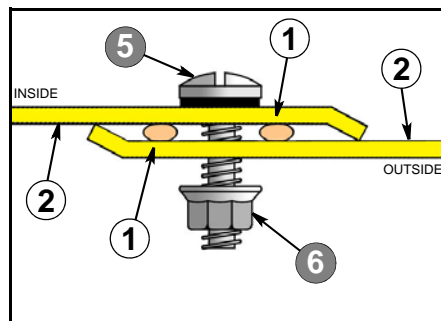

Item	Description
1	Caulking
2	Hopper Panel
3	Body Sheet
4	Hopper Collar
5	Bolt, Truss Head
6	Nut, Flange
7	Leg Holes

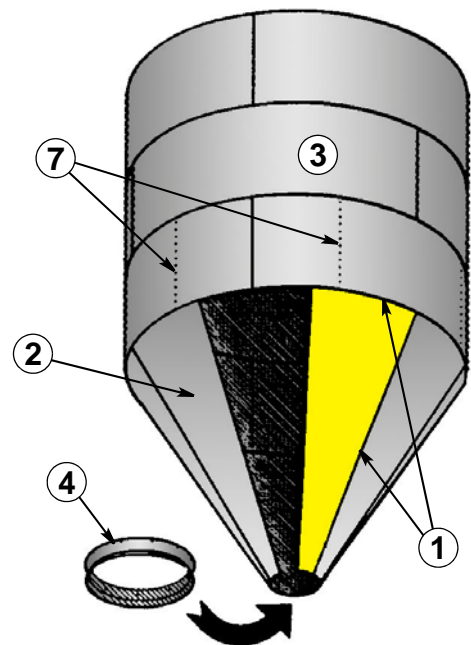

Figure 31.
Hopper Assembly

Hopper Collar

Install the Hopper Collar so the input Access Hole is located **away** from the Auger and as near as possible **midway between** a set of Legs. If this hole is not used for accessory equipment, install the Hole Cover Plate (3-19040) over the hole (see *, **Figure 32**) with Truss Head Bolts and Flange Nuts. Apply Caulk.

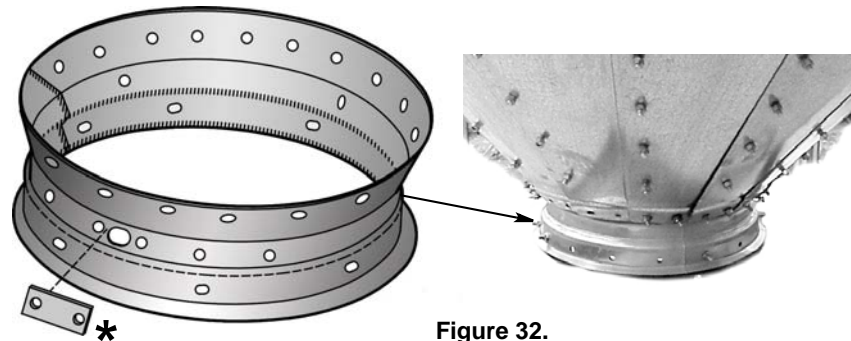

Figure 32.
Hopper Collar Access Hole and Hole Cover Plate*

Install the last Hopper Panel and tighten all Bolts.

Use 5/16 x 3/4" Truss Head Bin Seal Gr. 8.2 Bolts and 5/16" Flange Nuts to attach the Hopper Brace to the Collar. This hardware is packaged with the Collar.

The proper Collar/Brace diagram is shown with individual Bins in **Figures 40-45**.

IMPORTANT! *A 16" [406] Reinforced Collar is required when a TWIN UPPER BOOT is used. Failure to do this may cause Bin damage and may void the Bin Warranty.*

Hopper Reinforcement Angle

Angles should be ordered for **any** bin in which difficult flowing materials such as soybean meal, etc., will be stored.

IMPORTANT! *Cut Hopper Reinforcement Angles as necessary at the bottom end for 25" [635] Hopper openings.*

The Angle must be tight against **outside** of the Hopper Panel. Do not use double nuts.

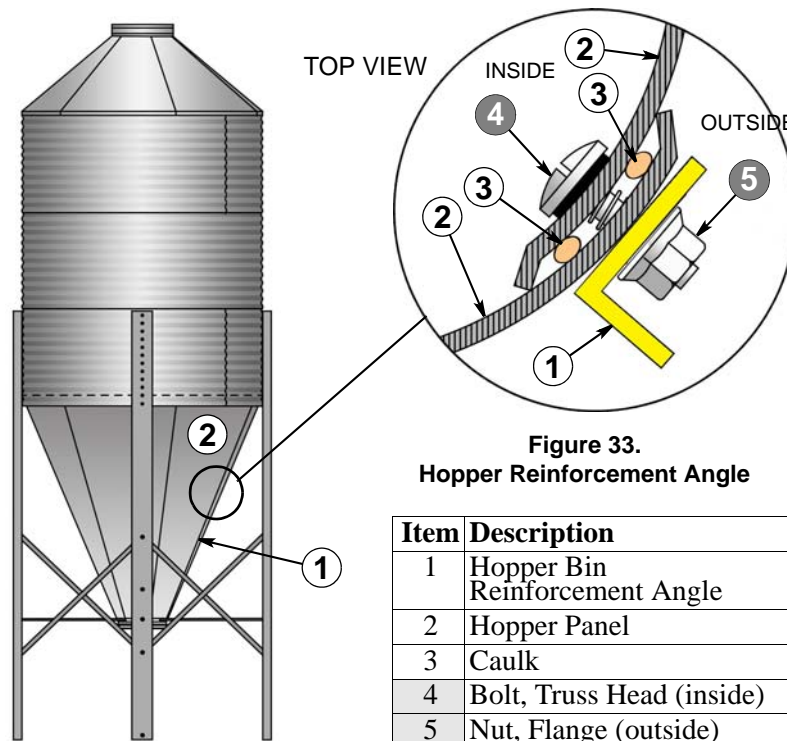

Figure 33.
Hopper Reinforcement Angle

Item	Description
1	Hopper Bin Reinforcement Angle
2	Hopper Panel
3	Caulk
4	Bolt, Truss Head (inside)
5	Nut, Flange (outside)

Legs and Braces

Hopper Braces to Legs

With the Collar installed, attach Hopper Braces. These radiate outward from the Hopper Collar to the Legs. Hopper Brace **spacing** is very important. Follow the diagram for your size bin in **Figures 40-45**. There are no Hopper Braces used on the 18' [5 486] and 21' [6 401] diameter Hopper Bins.

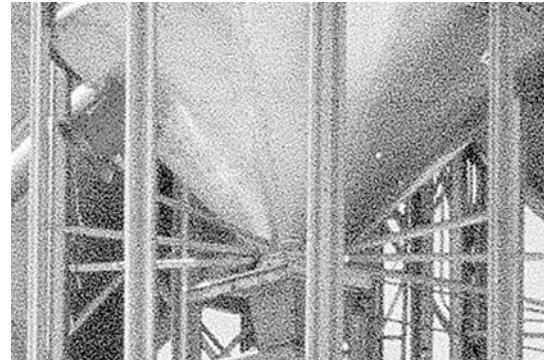

Figure 34.
Hopper Braces

X-Braces Between Legs

X-Braces are marked with fluorescent green for inside and fluorescent red for outside. Install **inside** Braces first.

Install Hopper Braces and X-Braces to Legs using 3/8 x 1" Hex Head Gr. 8 Bolts and 3/8" Nuts.



Figure 35.
Brace Attachment

Standard Hopper Bin Leg Anchoring

Item	Description
1	Leg
2	Concrete Shim
3	Leg Anchor
4	Leg Anchor Plate
5	Bolt, Bin Seal 5/16-18 x 1" Gr. 8.2
6	Nut, Flange 5/16"-18
7	Washer, Heavy 5/8" 39-20077
8	Nut, Hex 5/8"-11
9	Anchor Rod 5/8-11 x 8 x 2"

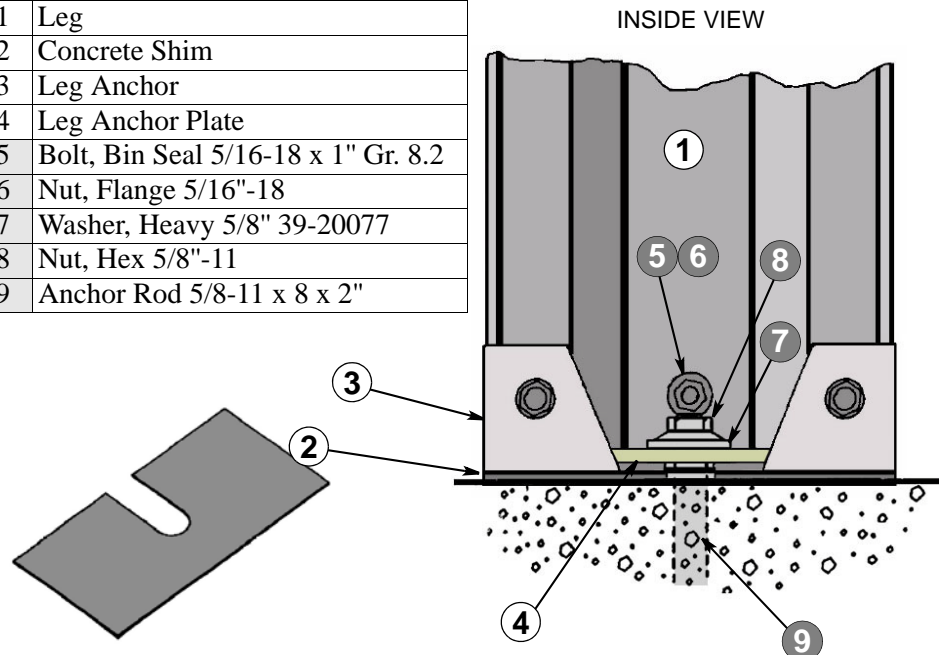
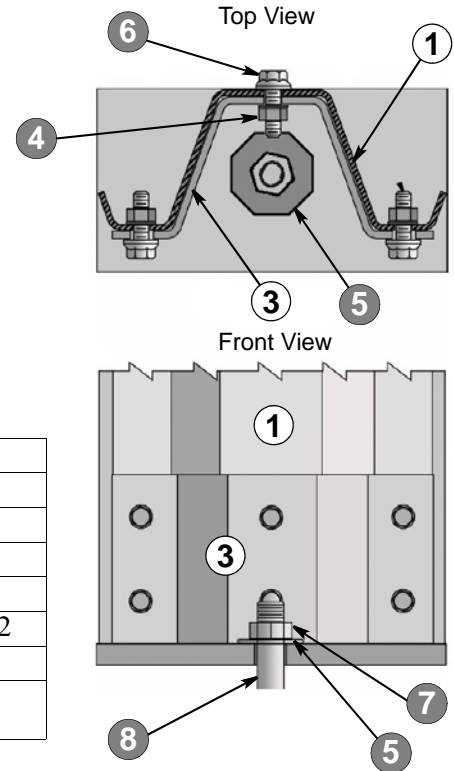
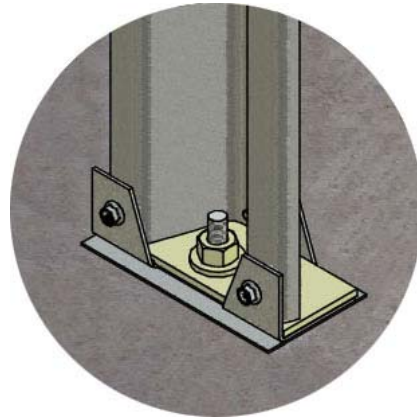

Figure 36.
Standard Leg Anchoring

Attach the Leg Anchor and Plate to the bottom of the bin Legs. Lower the bin onto the Anchor Rods. Place the 5/8" Heavy Washer over the Anchor Rod and tighten the 5/8" Nut by hand. Insert Concrete Shims as needed to level the bin and make sure all Legs are resting firmly on the foundation.

The Leg Anchor Weldment is attached to the bottom of the leg on the 12' 60° 11-Ring Bin. Anchor placement information is on pages 16-17. Tighten all Bolts.



Item	Description
1	Leg
3	Foot Weldment
4	5/16" Flange Nut
5	Washer, Octagon 5/8" 39-51026
6	Bolt, Bin Seal 5/16-18 x 1" Gr. 8.2
7	Nut, Heavy 5/8"-11
8	Anchor Bolt, Heavy Hex Head 5/8-11 x 12"

Figure 37. Leg Anchor Weldment

Anchoring the Leg to Support Structure Beam

Support Structure and Foundation Designs are available from Brock on request. Other designs by professional engineers may be used.

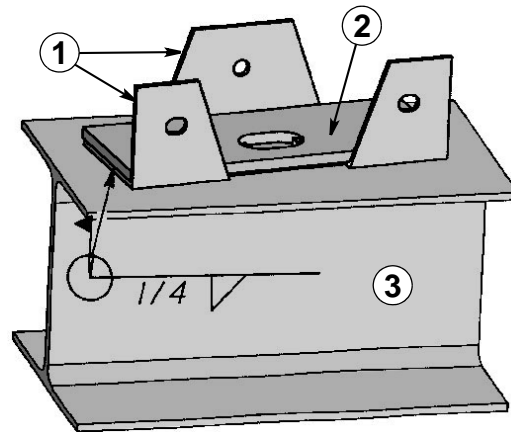

Item	Description
1	Leg Anchor
2	Leg Anchor Plate
3	Support Structure Beam

Figure 38. Anchoring Leg to Support Beam

Bin Grounding

All bins shall have **two** Ground Connections. Ground Clamps must be spaced equally around the bin.

For alternate installations, cables may be placed in the foundation or through a PVC sleeve inserted in the slab during construction.

IMPORTANT! *Make sure electrical equipment is properly installed and grounded by a qualified electrician according to the National Electrical Code.*

Parts should be purchased locally.

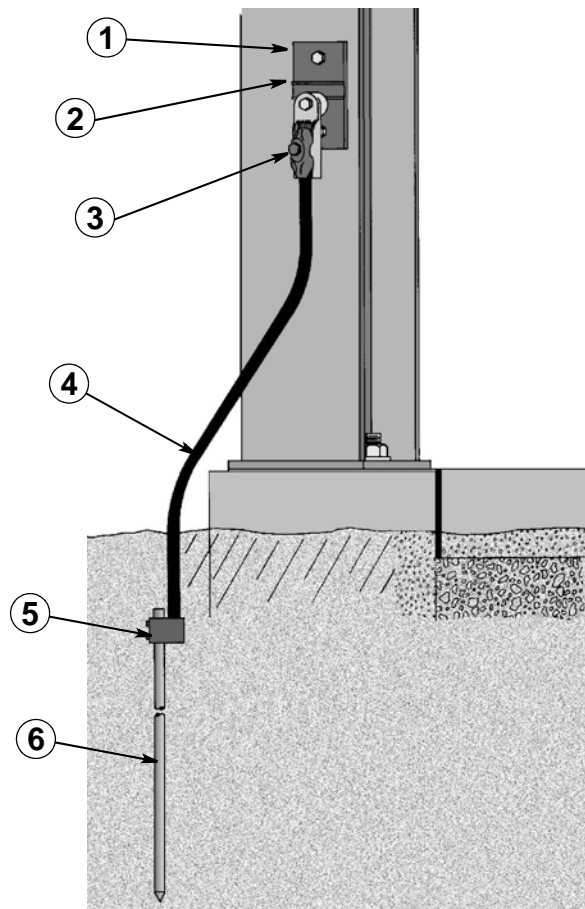

Item	Description
1	Heavy Duty Metal Bonding
2	Plate
3	Swivel Cable Clamp
4	Copper Cable
5	Ground Rod Clamp
6	Ground Rod

Figure 39.
Bin Grounding

Bin Assembly Diagrams

12' [3 658] Diameter 45° Hopper Bin

* Sealant placement

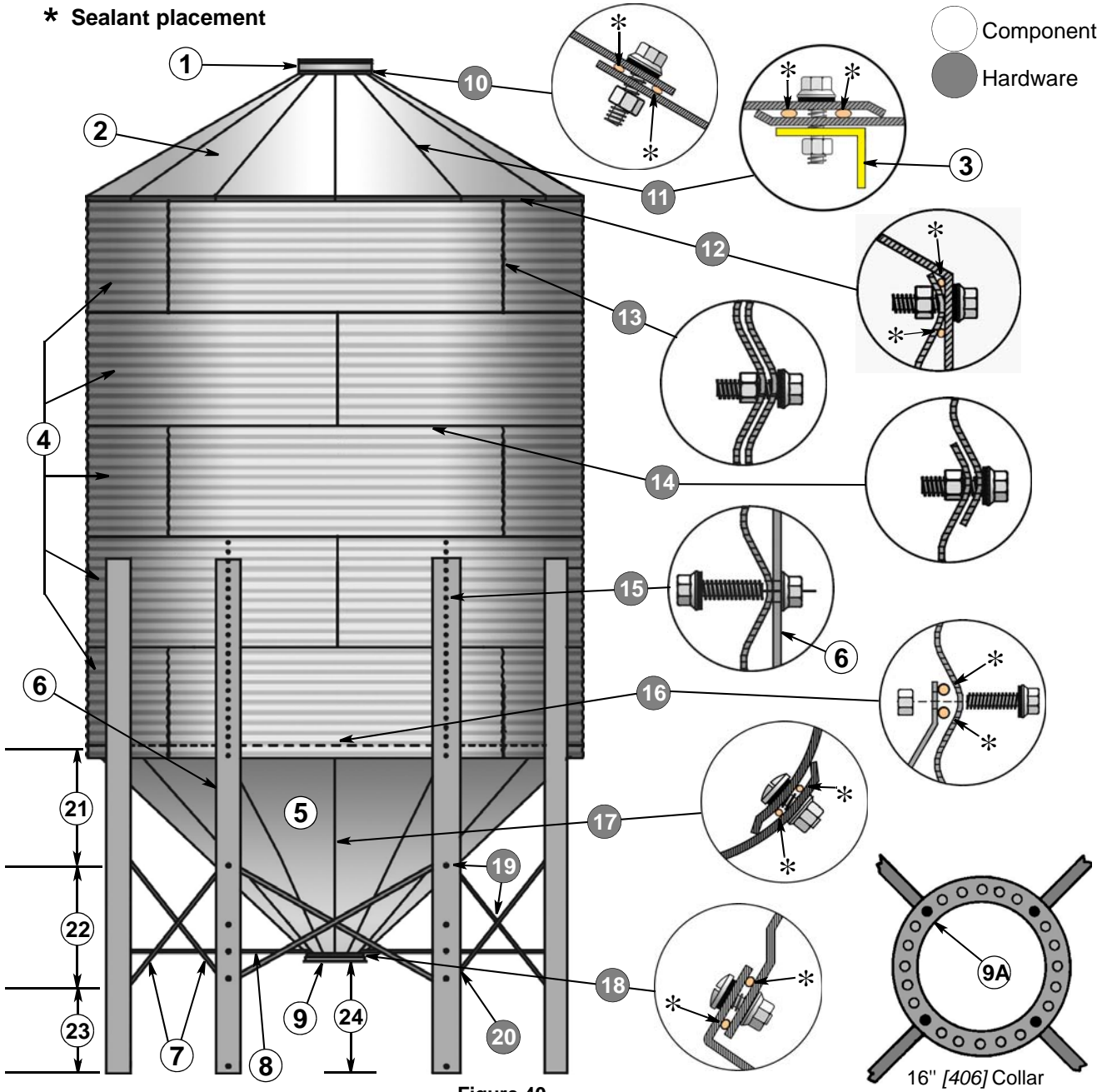
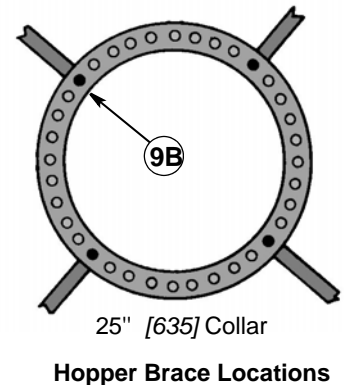

Figure 40.

BODY SHEET GAUGE CHART											
BODY SHEET RINGS	Model Numbers										
	01231	01232	01233	01234	01235	01236	01237	01238	01239	012310	012311
top	18	20	20	20	20	20	20	20	20	20	20
2		14	20	20	20	20	20	20	20	20	20
3			13	18	18	18	18	18	18	18	18
4				13	16	16	16	16	16	16	16
5					12	15	15	14	14	14	14
6						12	13	13	13	13	13
7							12	12	12	12	12
8								12	12	12	12
9									12	11	11
10										11	10
11											10



12' [3 658] Diameter 45° Hopper Bin

Item	Part No.	Description	Qty.
1	3-32835	Fillhole Collar 22" [559]	1
2	3-12050	Roof Panel, Standard 30° 20 ga.	12
3	3-16042	30° Roof Reinforcement Angle, 16 ga. 69 1/4" (used under Roof Ladder)	2
12' [3 658] Body Sheets - 4 sheets per ring			
4	3-12053	20 ga. (top/mid) 2-11 rings	
	3-14318	18 ga. (mid) 4-11 rings	
	3-33283	18 ga. (bottom/2 Leg) 1 ring	
	3-12055	16 ga. (mid) 5-11 rings	
	3-33285	15 ga. (mid) 7 rings	
	3-33286	15 ga. (mid/2 Leg) 6 rings	
	3-12056	14 ga. (mid) 8-11 rings	
	3-33287	14 ga. (bottom/2 Leg) 2 rings	
	3-33288	13 ga. (mid) 8-11 rings	
	3-33289	13 ga. (mid/2 Leg) 7 rings	
	3-12057	12 ga. (mid) 9-11 rings	
	3-33290	13 ga. (bottom/2 Leg) 3-4 rings	
	3-33291	12 ga. (mid/2 Leg) 8 rings	
	3-33292	12 ga. (mid/3 Leg) 9 rings	
	3-33293	12 ga. (bottom/2 Leg) 5-8 rings	
	3-33294	12 ga. (bottom/3 Leg) 9 rings	
3-33295	11 ga. (mid) 11 rings		
3-33296	11 ga. (mid/3 Leg) 10 rings		
3-33297	11 ga. (bottom/3 Leg) 10 rings		
3-33298	10 ga. (mid/3 Leg) 11 rings		
3-33299	10 ga. (bottom/3 Leg) 11 rings		
5	3-16619	Joggled Hopper Panel - 16" [406] 14 ga.	12 or 12
	3-12060	Hopper Panel - 25" [635] 14 ga.	
6	3-33190	Leg 127 1/16" [3 227] O.A. 12 ga. 1-5 rings	1 Ring attachment 8 or
	3-18517	Leg 153 3/4" [3 905] O.A. 10 ga. 6-7 rings	8 or
	3-33192	Leg 153 3/4" [3 905] O.A. 10 ga. 9-10 rings	12 or
		Leg 153 3/4" [3 905] O.A. 8 ga. 8 rings	8 or
3-33192	Leg 153 3/4" [3 905] O.A. 8 ga. 11 rings	12	
7	3-27574	X-Brace (inside) fluorescent green, 1-8 rings, 12 ga.	8
	3-27575	X-Brace (outside) fluorescent red, 1-8 rings, 12 ga.	8
	3-33611	X-Brace (inside) fluorescent green, 3 Legs/Body Sheet, 9-11 rings, 10 ga.	12
	3-33612	X-Brace (outside) fluorescent red, 3 Legs/Body Sheet, 9-11 rings, 10 ga.	12
8	3-13236	16" [406] Hopper Brace	4 or
	3-12837	25" [635] Hopper Brace	4
9A	3-16890	16" [406] 45° Collar for Joggled Hopper	1 or
9B	3-13286	25" [635] 45° Collar and Plate Weldment	1
IMPORTANT: All Bolts MUST be tightened from the Nut side. See page 22.			
10	39-20073	Fillhole Assembly to Roof Panels - Use 5/16 x 1" Bin Seal Gr. 8.2 Bolts	36
	39-20020	and Hex Nuts.	36
11	39-20073	Roof Panel to Roof Panel - Use 5/16 x 1" Hex Head Bin Seal Gr. 8.2 Bolts, heads on outside	216
	39-20020	of Bin, and Hex Nuts on the inside .	216
12	39-20073	Roof Panels to Top Body Sections - Use 5/16 x 1" Bin Seal Gr. 8.2 Bolts	144
	39-20020	and Hex Nuts.	144
13	39-20073	Vertical Body Seams - Use 5/16 x 1" Bin Seal Gr. 8.2 Bolts	varies
	39-20020	and Hex Nuts.	varies
14	39-20073	Horizontal Body Seams - Use 5/16 x 1" Bin Seal Gr. 8.2 Bolts	varies
	39-20020	and Hex Nuts.	varies
15	39-20073	Leg Bolts - Use 5/16 x 1" Bin Seal Gr 8.2 Bolts, heads inside Bin,	96 (1-5 R)
	39-20152	and Flange Nuts on the outside .	192 (6-8 R) 288 (9-11 R)
16	39-20073	Hopper Panels to Body Sections - Use 5/16 x 1" Bin Seal Gr. 8.2 Bolts	136 or
	39-20020	and Hex Nuts.	132
17	39-20145	Vertical Hopper Seams - Use 5/16 x 3/4" Truss Head Bin Seal Gr. 8.2 Bolts, heads inside	336
	39-20152	Bin, and Flange Nuts on outside .	336
18	39-20145	Collar to Hopper - Use 5/16 x 3/4" Truss Head Bin Seal Gr. 8.2 Bolt, heads inside Bin,	18
	39-20152	and Flange Nuts outside .	18
19	39-20132	X-Braces to Legs and where the Braces cross - Use 3/8 x 1" Hex Head Gr. 8 Bolt	24 (1-8R)
	39-20114	and 3/8" Hex Nuts.	36 (9-11R)
20	39-20132	Hopper Braces to Legs - Use 3/8 x 1" Hex Head Gr. 8 Bolts	4
	39-20114	and 3/8" Hex Nuts.	4
21		38 5/8" [981]	
22		37 5/16" [947.7]	
23		23 7/8" [606.4]	
24		Under Collar Clearance: 31 5/8" [803] for 16" [406] Collar, or 42 1/4" [1 073] for 25" [635] Collar	

12' [3 658] Diameter 60° Hopper Bin

* Sealant placement

○ Component
● Hardware

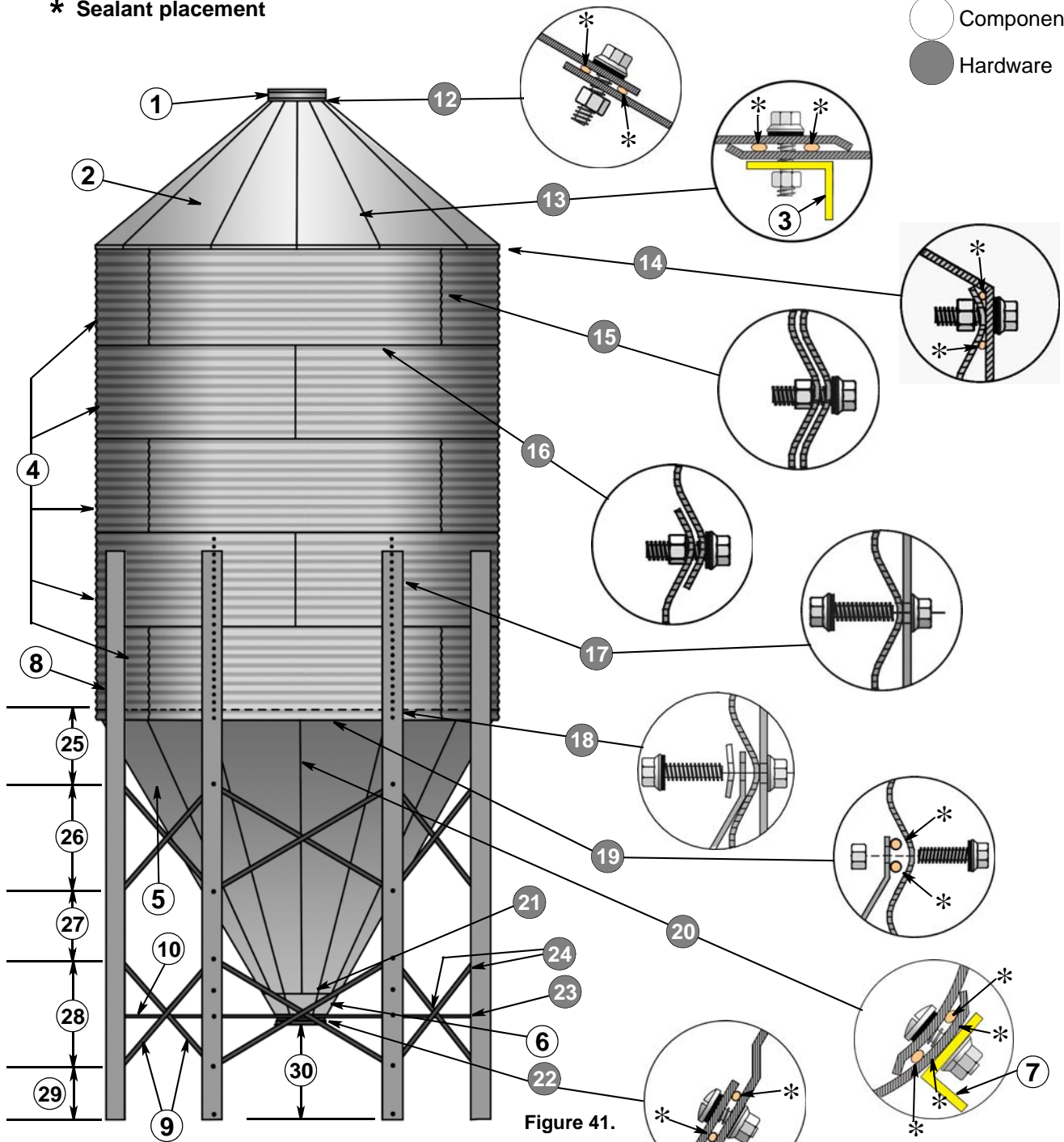
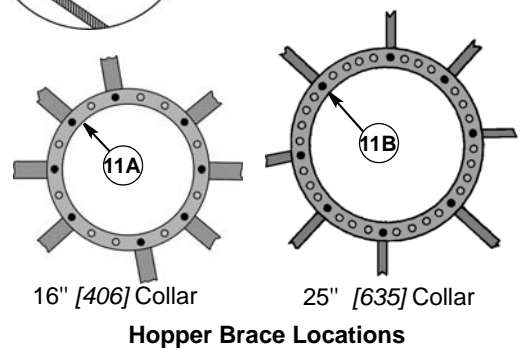

Figure 41.

BODY SHEET GAUGE CHART

BODY SHEET RINGS	Model Numbers										
	01201	01202	01203	01204	01205	01206	01207	01208	01209	012010	012011
top	18	20	20	20	20	20	20	20	20	20	20
2		14	20	20	20	20	20	20	20	20	20
3			13	18	18	18	18	18	18	18	18
4				13	16	16	16	16	16	16	16
5					12	15	15	14	14	14	14
6						12	13	13	13	13	13
7							12	12	12	12	12
8								12	12	12	12
9									12	11	11
10										11	10
11											10



16" [406] Collar 25" [635] Collar
Hopper Brace Locations

12' [3 658] Diameter 60° Hopper Bin

Item	Part No.	Description	Qty.
1	3-32835	Fillhole Collar 22" [559]	1
2	3-33165	Roof Panel, Standard 40° 18 ga.	12
3	3-33417	40° Roof Reinforcement Angle, 16 ga. 77 1/4" (used under Roof Ladder)	2
12' [304.8] Body Sheets - 4 sheets per ring			
4	3-12053	20 ga. (top/mid) 2-11 rings	
	3-14318	18 ga. (mid) 4-11 rings	
	3-33283	18 ga. (bottom/2 Leg) 1 rings	
	3-12055	16 ga. (mid) 5-11 rings	
	3-33285	15 ga. (mid) 7 rings	
	3-33286	15 ga. (mid/2 Leg) 6 rings	
	3-12056	14 ga. (mid) 8-11 rings	
	3-33287	14 ga. (bottom/2 Leg) 2 rings	
	3-33288	13 ga. (mid) 8-11 rings	
	3-33289	13 ga. (mid/2 Leg) 7 rings	
	3-12057	12 ga. (mid) 9-11 rings	
	3-33291	12 ga. (mid/2 Leg) 8 - 9 rings	
5	3-12839	Hopper Panel - 25" [635] 14 ga.	12
6	3-16623	Hopper Extension Plate 60° joggled 16 ga.	6
7	3-16508	Hopper Reinforcement Angle - 12' 60°, 12 ga. 120 1/4" [305.4]	12 pc
8	3-33194	Leg 173 3/4" [4 413] O.A. 12 ga. 1-5 rings	1 Ring attachment 8 or
	3-18518	Leg 200 3/8" [5 090] O.A. 10 ga. 6-7 rings	8 or
		Leg 200 3/8" [5 090] O.A. 10 ga. 9 rings	12 or
	3-45217	Leg 200 3/8" [5 090] O.A. 8 ga. 8 rings Leg 200 3/8" [5 090] O.A. 8 ga. 10-11 rings	8 or 12
9	3-27574	X-Brace (inside) fluorescent green, 1-8 rings, 12 ga.	16
	3-27575	X-Brace (outside) fluorescent red, 1-8 rings, 12 ga.	16
	3-33611	X-Brace (inside) fluorescent green, 3 Legs/Body Sheet, 9-11 rings, 10 ga.	24
	3-33612	X-Brace (outside) fluorescent red, 3 Legs/Body Sheet, 9-11 rings, 10 ga.	24
10	3-32758	16" [406] Hopper Brace	8(1-8R) or 6(9-11R) or 8(1-8R) or 6(9-11R)
	3-12837	25" [635] Hopper Brace	
11A	3-32466	Reinforced Hopper Collar 60° 16" [406]	1 or
11B	3-13284	Collar and Plate Weldment 25" [635] 45°	1
IMPORTANT: All Bolts MUST be tightened from the Nut side. See page 22.			
12	39-20073	Fillhole Assembly to Roof Panels - Use 5/16 x 1" Bin Seal Bolts Gr. 8.2	36
	39-20020	and Hex Nuts.	36
13	39-20073	Roof Panel to Roof Panel - Use 5/16 x 1" Hex Head Bin Seal Gr. 8.2 Bolts, heads outside Bin	228
	39-20020	and Hex Nuts inside .	228
14	39-20073	Roof Panels to Top Body Sections - Use 5/16 x 1" Bin Seal Gr. 8.2 Bolts	144
	39-20020	and Hex Nuts.	144
15	39-20073	Vertical Body Seams - Use 5/16 x 1" Bin Seal Gr. 8.2 Bolts	varies
	39-20020	and Hex Nuts.	varies
16	39-20073	Horizontal Body Seams - Use 5/16 x 1" Bin Seal Gr. 8.2 Bolts	varies
	39-20020	and Hex Nuts.	varies
17	39-20073	Leg Bolts - Use 5/16 x 1" Bin Seal Gr. 8.2 Bolts, heads INSIDE Bin.	88 (1-5 R)
	39-20152	Flange Nuts outside . (See exception below, Key 17.)	188(6-8R) 276(9-11R)
18	39-20152	Leg-to-Body-to-Hopper Bolt - Use 5/16 x 1" Bin Seal Gr. 8.2 Bolts, heads inside Bin.	8 (1-8R)
	39-20073	Flange Nuts on the outside .	12 (9-11R)
	39-20074	Curved washer on the inside .	
19	39-20073	Hopper Panels to Body Sections - Use 5/16 x 1" Bin Seal Gr. 8.2 Bolts	136 (1-8R) or
	39-20020	and Hex Nuts.	132 (9-11R)
20	39-20145	Vertical Hopper Seams - Use 5/16 x 3/4" Truss Head Bin Seal Gr. 8.2 Bolts, heads inside Bin.	468
	39-20152	Flange Nuts outside .	468
21	39-20145	Hopper Panel to Extension Plates - 5/16 x 3/4" Truss Head Bin Seal Bolts, heads inside Bin.	36
	39-20152	Flange Nuts outside .	36
22	39-20145	Collar to Hopper - Use 5/16 x 3/4" Truss Head Bin Seal Gr. 8.2 Bolts, heads inside Bin.	18
	39-20152	Flange Nuts outside .	18
23	39-20132	Hopper Braces to Legs - Use 3/8 x 1" Hex Head Gr. 8 Bolt	8(1-8R)
	39-20114	and 3/8" Hex Nuts.	6(9-11R)
24	39-20132	X-Braces to Legs and where the Braces cross - Use 3/8 x 1" Hex Head Gr. 8 Bolts	48 (1-8R)
	39-20114	and 3/8" Hex Nuts.	72 (9-11R)
25		30 1/8" [764.6]	
26		37 5/16" [947.7]	
27		23 3/8" [593.7]	
28		37 5/16" [947.7]	
29		18 5/16" [465.1]	
30		Under Collar Clearance: 31 1/2" [800] for 16" [406] Collar; 42 1/4" [1 073] for 25" [635] Collar	

15' [4 572] Diameter 45° Hopper Bin

* Sealant placement

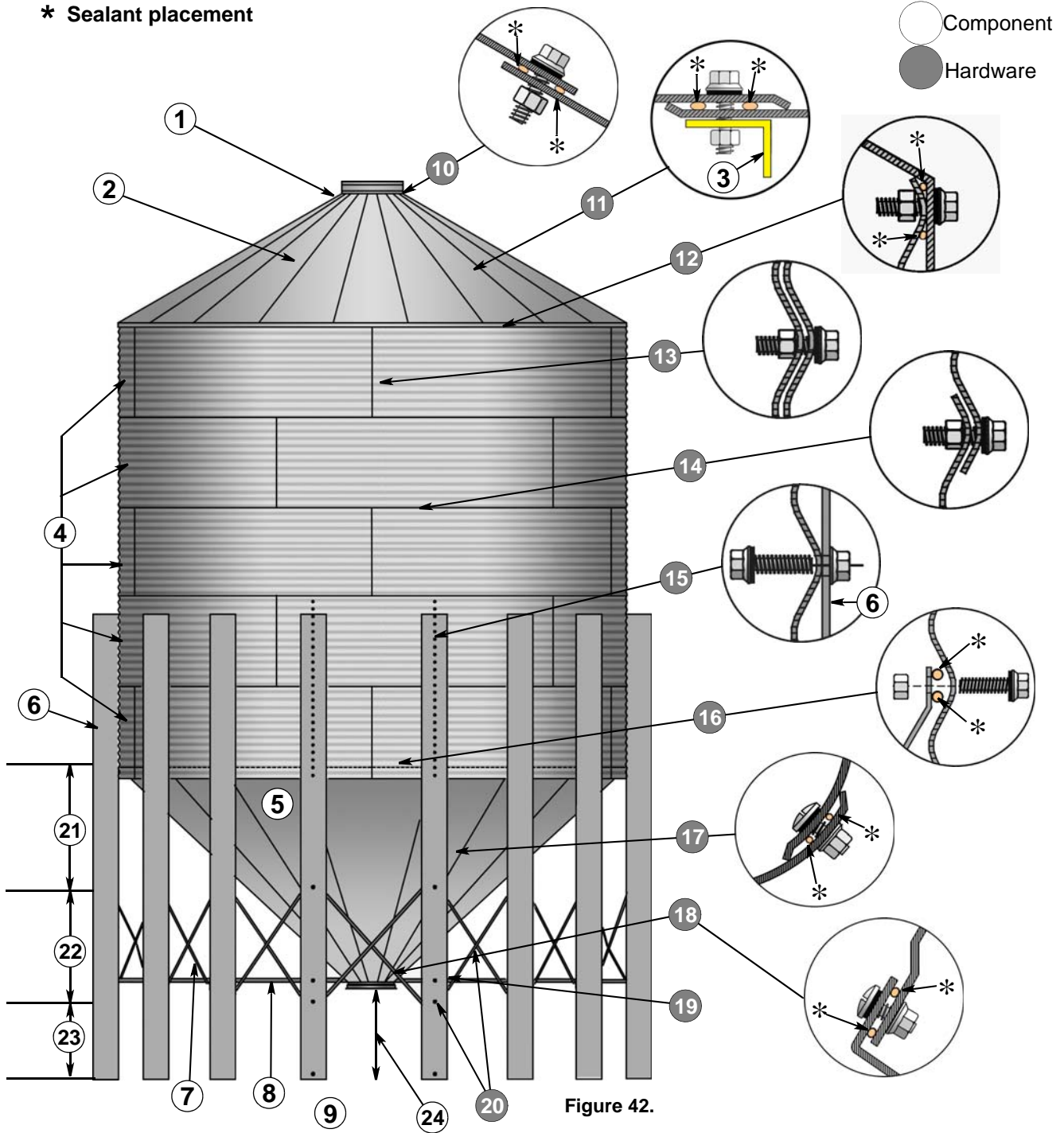

BODY SHEET GAUGE CHART								
BODY SHEET RINGS	Model Numbers							
	01532	01533	01534	01535	01536	01537	01538	01539
top	18	20	20	20	20	20	20	20
2	13	18	20	20	20	20	20	20
3		13	18	18	18	18	18	18
4			13	16	16	16	16	16
5				12	14	14	14	15
6					12	13	13	13
7						12	12	13
8							12	12
9								11

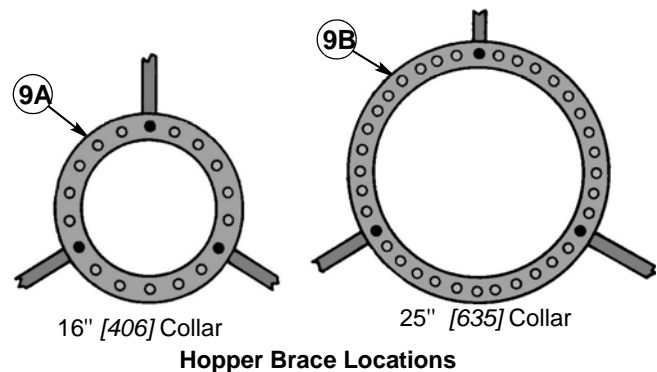

15' [4 572] Diameter 45° Hopper Bin

Item	Part No.	Description	Qty.
1	3-32835	Fillhole Collar 22" [559]	1
2	3-13858	Roof Panel, Standard 30° 20 ga. For Raised Rib, see the supplemental Roof Manual, MGB1496	18
3	3-13880	30° Roof Reinforcement Angle, 16 ga., 89 1/4" (used under Roof Ladder and every third roof seam)	7
15' [4 572] Body Sheets - 5 sheets per ring			
4	3-13862	20 ga. (top/mid) 3-9 rings	
	3-14327	18 ga. (mid) 5-9 rings	
	3-13863	18 ga. (top/mid/3 Leg) 2-4 rings	
	3-13864	16 ga. (mid) 6-9 rings	
	3-14328	16 ga. (mid/3 Leg) 5 rings	
	3-33310	15 ga. (mid) 9 rings	
	3-33311	14 ga. (mid) 7-8 rings	
	3-33312	14 ga. (mid/3 Leg) 6 rings	
	3-33314	13 ga. (mid) 8-9 rings	
	3-33315	13 ga. (mid/3 Leg) 7 rings	
	3-33316	13 ga. (bottom/3 Leg) 2-4 rings	
	3-33317	12 ga. (mid/3 Leg) 8-9 rings	
	3-33318	12 ga. (bottom/3 Leg) 5-8 rings	
3-33319	11 ga. (bottom/3 Leg) 9 rings		
5	3-16621	Joggled Hopper Panel - 16" [406] 14 ga.	18 or
	3-13870	Hopper Panel - 25" [635] 14 ga.	18
6	3-18519	Leg 171.750" [4 362] O.A. 10 ga. 2-7 rings	15 or
	3-33200	Leg 171.750" [4 362] O.A. 8 ga. 8-9 rings	15
7	3-32619	X-Brace (inside) fluorescent green, 10 ga.	15
	3-32620	X-Brace (outside) fluorescent red, 10 ga.	15
8	3-32901	16" [406] Hopper Braces, 12 ga.	3 or
	3-13872	25" [635] Hopper Braces, 12 ga.	3
9A	3-16890	16" [406] 45° Collar for Joggled Hopper	1 or
9B	3-13286	25" [635] 45° Collar and Plate Weldment	1
IMPORTANT: All Bolts MUST be tightened from the Nut side. See page 22.			
10	39-20073	Fillhole Assembly to Roof Panels - Use 5/16 x 1" Bin Seal Bolts Gr. 8.2	36
	39-20020	and Hex Nuts.	36
11	39-20073	Roof Panel to Roof Panel - Use 5/16 x 1" Hex Head Bin Seal Gr. 8.2 Bolts, heads outside Bin,	414
	39-20020	and Hex Nuts inside .	414
12	39-20073	Roof Panels Top Body Sections - Use 5/16 x 1" Bin Seal Gr. 8.2 Bolts	180
	39-20020	and Hex Nuts.	180
13	39-20073	Vertical Body Seams - Use 5/16 x 1" Bin Seal Gr. 8.2 Bolts	varies
	39-20020	and Hex Nuts.	varies
14	39-20073	Horizontal Body Seams - Use 5/16 x 1" Bin Seal Gr. 8.2 Bolts	varies
	39-20020	and Hex Nuts.	varies
15	39-20073	Leg Bolts (Bolt Heads are inside of Bin.) Use 5/16 x 1" Bin Seal Gr. 8.2 Bolts	360
	39-20152	and Flange Nuts outside .	360
16	39-20073	Hopper Panels to Body Sections - Use 5/16 x 1" Bin Seal Gr. 8.2 Bolts	165
	39-20020	and Hex Nuts. Start on the Body Sheet Seam.	165
17	39-20145	Vertical Hopper Seams - Use 5/16 x 3/4" Truss Head Bin Seal Gr. 8.2 Bolts, heads inside Bin,	810
	39-20152	and Flange Nuts outside .	810
18	39-20145	Collar to Hopper - Use 5/16 x 3/4" Truss Head Bin Seal Gr. 8.2 Bolts, heads inside Bin,	18
	39-20152	and Flange Nuts outside .	18
19	39-20132	Hopper Brace to Leg - Use 3/8 x 1" Hex Head Gr. 8 Bolts	3
	39-20114	and 3/8" Hex Nuts.	3
20	39-20132	X Braces to Legs and Center - Use 3/8 x 1" Hex Head Gr. 8 Bolts	45
	39-20114	and 3/8" Hex Nuts.	45
21		45 13/16" [1 163.1]	
22		48" [1 219]	
23		24" [609.6]	
24		Under Collar Clearance:	
		32 1/2" [826] for 16" [406] Collar 42 3/4" [1 086] for 25" [635] Collar	

15' [4 572] Diameter 60° Hopper Bin

* Sealant placement

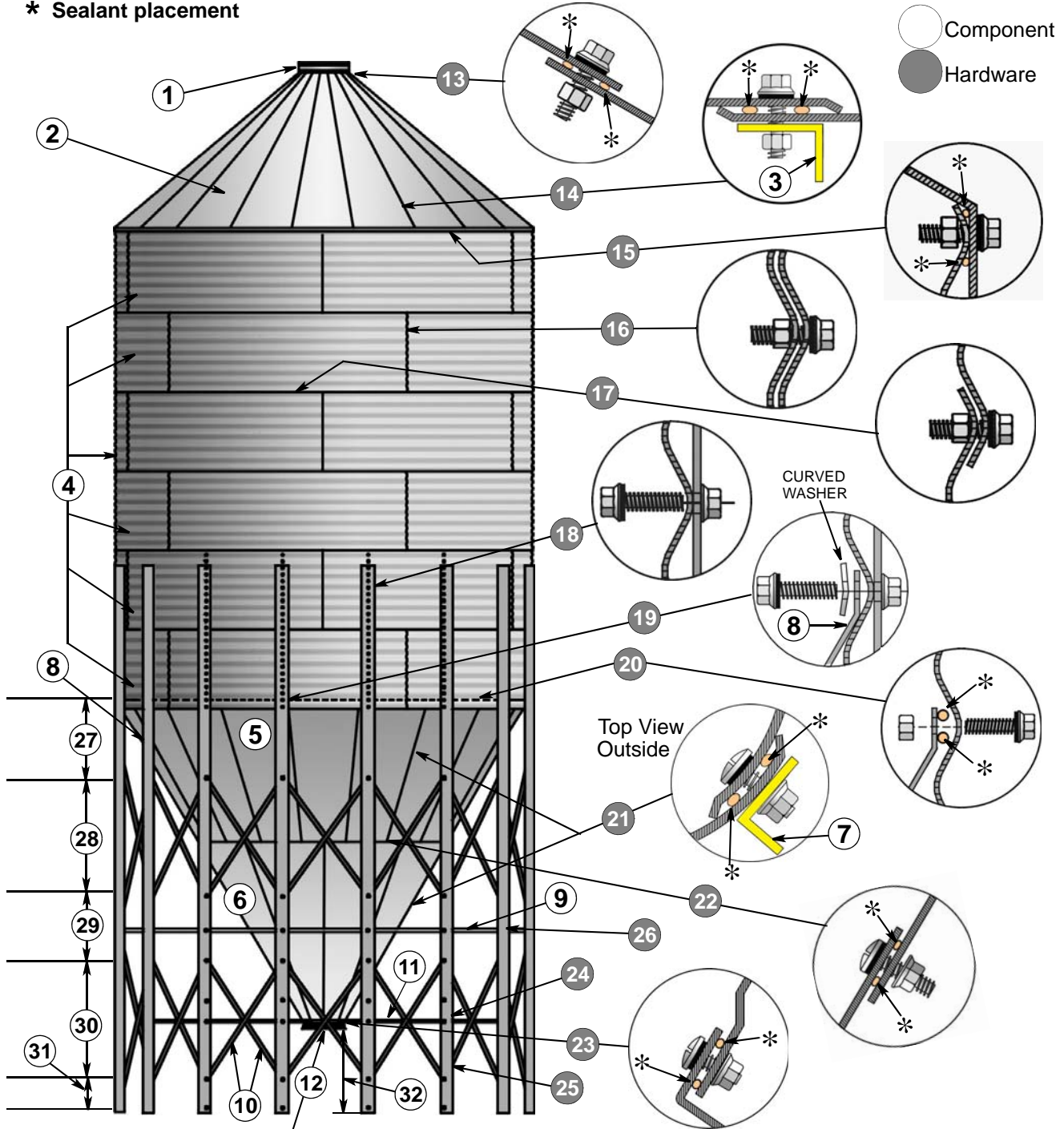
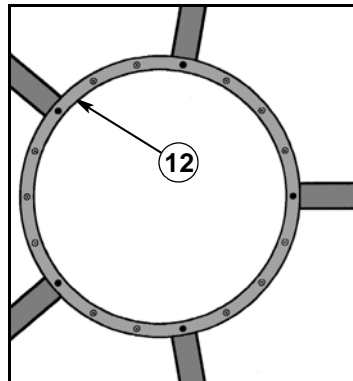

Figure 43.



BODY SHEET GAUGE CHART

BODY SHEET RINGS	Model Numbers									
	01502	01503	01504	01505	01506	01507	01508	01509	01510	
top	18	20	20	20	20	20	20	20	20	
2	13	18	20	20	20	20	20	20	19	
3		13	18	18	18	18	18	18	17	
4			13	16	16	16	16	16	15	
5				12	14	14	14	14	14	
6					12	13	13	13	13	
7						12	12	12	12	
8							12	12	11	
9								12	11	
10									11	

15' [4 572] Diameter 60° Hopper Bin

Item	Part No.	Description	Qty.
1	3-32835	Fillhole Collar 22" [559]	1
2	3-33168	Roof Panel, Standard 40° 18 ga. For Raised Rib, see supplemental Roof Manual MGB1496.	18
3	3-33418	40° Roof Reinforcement Angles 12 ga., 101 1/4"	18
15' [4 572] Body Sheets - 5 sheets per ring			
4	3-13862	20 ga. (top/mid) 3-10 rings	
	3-35640	19 ga. (mid) 10 rings	
	3-14327	18 ga. (mid) 5-9 rings	
	3-13863	18 ga. (top/mid/3 Leg) 2 rings	
	3-35641	17 ga. (mid) 10 rings	
	3-13864	16 ga. (mid) 6-9 rings	
	3-33310	15 ga. (mid) 10 rings	
	3-14328	16 ga. (mid/3 Leg) 5 rings	
	3-33311	14 ga. (mid) 7-10 rings	
	3-33312	14 ga. (mid/3 Leg) 6 rings	
	3-33314	13 ga. (mid) 8-10 rings	
	3-33315	13 ga. (mid/3 Leg) 7 rings	
	3-33316	13 ga. (bottom/3 Leg) 2-4 rings	
	3-33317	12 ga. (mid/3 Leg) 8-9 rings	
	3-33318	12 ga. (bottom/2 Leg) 5-9 rings	
	3-35642	12 ga. (mid) 9-10 rings	
3-35643	11 ga. (mid) 10 rings		
3-35644	11 ga. (mid/3 Leg) 10 rings		
3-33319	11 ga. (bottom/3 Leg) 10 rings		
5	3-22730	Upper Hopper Panel 12 ga.	18
6	3-22731	Lower Hopper Panel - Joggled 16" [406] 16 ga.	9 or
	3-22732	Lower Hopper Panel - 25" [635] 16 ga.	9
7	3-25330	Upper Hopper Reinforcement Angle - 15' 60°, 12 ga., 70"	18
	3-22597	Lower Hopper Reinforcement Angle - 15' 60°, 12 ga. 87 1/4"	9
8	3-28720	Leg 230.8125" [5 863] O.A. 10 ga. 2-8 rings	15 or
	3-33204	Leg 230.8125" [5 863] O.A. 8 ga. 9-10 rings	15
9	3-13873	15' [4 572] Tie Brace, 2-6 rings (None required)	0
	3-13873	15' [4 572] Tie Brace, 7-10 rings	15
10	3-32619	X-Brace (inside) fluorescent green, 10 ga., 2-8 rings	30
	3-32620	X-Brace (outside) fluorescent red, 10 ga., 2-8 rings	30
	3-34464	X-Brace (inside) fluorescent green, 8 ga., 9-10 rings	30
	3-34465	X-Brace (outside) fluorescent red, 8 ga., 9-10 rings	30
11	3-32900	16" [406] Hopper Brace, 12 ga.	5 or
	3-13872	25" [635] Hopper Brace, 12 ga.	5
12	3-16888	16" [406] 60° Collar for Joggled Hopper	1 or
	3-13284	25" [635] 60° Collar and Plate Weldment	1
IMPORTANT: All Bolts MUST be tightened from the Nut side. See page 22.			
13	39-20073	Fillhole Assembly to Roof Panels - Use 5/16 x 1" Bin Seal Gr. 8.2 Bolts	36
	39-20020	and Hex Nuts.	36
14	39-20073	Roof Panel to Roof Panel - Use 5/16 x 1" Hex Head Bin Seal Gr. 8.2 Bolts	450
	39-20020	and Hex Nuts.	450
15	39-20073	Roof Panels to Top Body Sections - Use 5/16 x 1" Bin Seal Gr. 8.2 Bolts	180
	39-20020	and Hex Nuts.	180
16	39-20073	Vertical Body Seams - Use 5/16 x 1" Bin Seal Gr. 8.2 Bolts	varies
	39-20020	and Hex Nuts.	varies
17	39-20073	Horizontal Body Seams - Use 5/16 x 1" Bin Seal Gr. 8.2 Bolts	varies
	39-20020	and Hex Nuts.	varies
18	39-20073	Leg Bolts - Use 5/16 x 1" Bin Seal Gr. 8.2 Bolts, heads inside Bin,	345
	39-20152	and Flange Nuts outside . (See exception below, Key 19.)	345
19	39-20074	Leg-to-Body-to-Hopper Bolt - Use 3/8 x 1 1/2" Bin Seal Bolts, heads inside Bin,	15
	39-20323	and Hex Nut outside .	15
	39-20114	Curved Washer on inside .	15
20	39-20073	Upper Hopper Panels to Body Sections - Use 5/16 x 1" Bin Seal Gr. 8.2 Bolts	165
	39-20020	and Hex Nuts. Start on the Body Sheet Seam.	165
21	39-20350	Vertical Hopper Seams - Use 5/16 x 1" Truss Head Bin Seal Gr. 8.2 Bolts, heads inside Bin,	666
	39-20152	and Flange Nuts outside .	666
22	39-20350	Horizontal Hopper Seams - Use 5/16 x 1" Truss Head Bin Seal Gr. 8.2 Bolts, heads inside Bin,	108
	39-20152	and Flange Nuts outside .	108
23	39-20350	Collar to Hopper - Use 5/16 x 1" Truss Head Bin Seal Gr. 8.2 Bolts, heads inside Bin,	18
	39-20152	and Flange Nuts outside .	18
24	39-20132	Hopper Braces to Legs - Use 3/8 x 1" Hex Head Gr. 8 Bolts	5
	39-20114	and 3/8" Hex Nuts.	5
25	39-20132	X-Braces to Legs and Center - Use 3/8 x 1" Hex Head Gr. 8 Bolts	90
	39-20114	and 3/8" Hex Nuts (2-8 rings)	90
	39-20200	X-Braces to Legs and center - Use 1/2 x 1 1/4" Hex Head Gr. 8 Bolts	90
	39-20022	and 1/2" Hex Nuts (9-10 rings)	90
26	39-20132	Tie Brace to Legs - Use 3/8 x 1" Hex Head Gr. 8 Bolts	15
	39-20114	and 3/8" Hex Nuts (7-10 rings)	15
27		41 7/8" [1 063.6]	
28		48" [1 219]	
29		26" [660]	
30		48" [1 219]	
31		13" [330]	
32		Under Collar Clearance: 33 1/8" [841] for 16" [406] Collar, or 40 5/8" [1 032] for 25" [635] Collar	

18' [5 486] Diameter 45° Hopper Bin

* Sealant placement

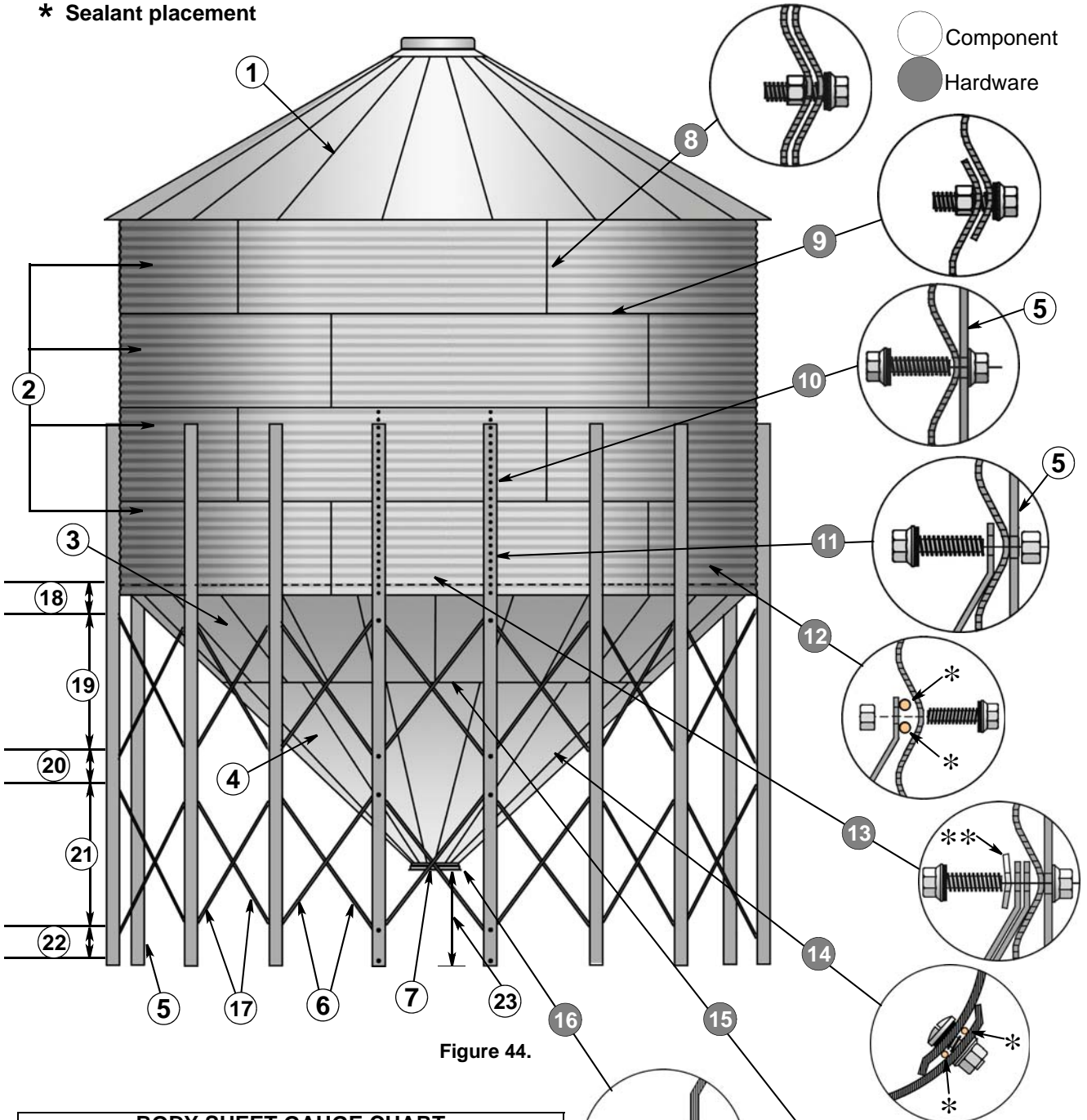

Figure 44.

BODY SHEET GAUGE CHART								
BODY SHEET RINGS	Model Numbers							
	01832	01833	01834	01835	01836	01837	01838	01839
top	16	20	20	20	20	20	20	20
2	14	16	20	20	20	20	20	20
3		14	16	19	19	19	18	18
4			14	16	17	17	16	16
5				12	16	15	15	14
6					12	14	13	13
7						11	13	13
8							11	12
9								10

18' [5 486] Diameter 45° Hopper Bin

Item	Part No.	Description	Qty.
1	9-23881	Raised Rib Roof Complete (3 panel, 30°). See the supplemental Roof Manual MGB1496.	1
18' [5 486] Body Sheets - 6 sheets per ring			
2	3-19666	20 ga. (top/mid) 3-9 rings	
	3-33320	19 ga. (mid) 5-7 rings	
	3-19669	18 ga. (mid) 8-9 rings	
	3-33321	17 ga. (mid) 6-7 rings	
	3-19670	16 ga. (mid) 8-9 rings	
	3-19667	16 ga. (mid/3 Leg) 2-6 rings	
	3-33322	15 ga. (mid) 7-8 rings	
	3-33323	14 ga. (mid) 9 rings	
	3-33324	14 ga. (mid/3 Leg) 7 rings	
	3-33325	14 ga. (bottom/3 Leg) 2-4 rings	
	3-33326	13 ga. (mid) 8-9 rings	
	3-33327	13 ga. (mid/3 Leg) 8 rings	
	3-33328	12 ga. (mid/3 Leg) 9 rings	
3-33329	12 ga. (bottom/3 Leg) 5-6 rings		
3-33330	11 ga. (bottom/3 Leg) 7-8 rings		
3-33331	10 ga. (bottom/3 Leg) 9 rings		
3	3-19653	Upper Hopper Panel - 12 ga. 45°	24
4	3-16622	Lower Hopper Panel - Joggled 16" [406] - 14 ga. 45°	14 or
	3-34975	Lower Hopper Panel - 25" [635] - 14 ga. 45°	14
5	3-19654	Leg 190.125" [4 829] O.A. 10 ga.	18(2-7R)
	3-33208	Leg 190.125" [4 829] O.A. 8 ga.	18(8-9R)
6	3-32621	X-Brace (inside) fluorescent green, 10 ga.	36
	3-32622	X-Brace (outside) fluorescent red, 10 ga.	36
7	3-16892	16" [406] 45° Collar for Joggled Hopper	1
IMPORTANT: All Bolts MUST be tightened from the Nut side. See page 22.			
8	39-20073 39-20020	Vertical Body Seams - Use 5/16 x 1" Bin Seal Gr. 8.2 Bolts, heads outside Bin, and Hex Nuts inside .	varies varies
9	39-20073 39-20020	Horizontal Body Seams - Use 5/16 x 1" Hex Head Bin Seal Gr. 8.2 Bolts, heads outside Bin, and Hex Nuts inside .	varies varies
10	39-20130 39-20152	Leg Bolts - Use 5/16 x 1 1/2" Bin Seal Gr. 8.2 Bolts, heads inside Bin, and Flange Nuts outside . (See exception below, Key 11.)	414 414
11	39-20323 39-20114	Leg-to-Body-to-Hopper Bolt - Use 3/8 x 1 1/2" Hex Head Bin Seal Gr. 8.2 Bolts, heads inside Bin, and Hex Nuts outside .	18 18
12	39-20130 39-20020	Upper Hopper Panels to Body sections - Use 5/16 x 1 1/2" Bin Seal Gr. 8.2 Bolts and Hex Nuts. Start center of first Hopper Panel on leg hole line.	174 174
13	39-20130 39-20020 39-20074	Use a 12 ga. Curved Washer** inside on 5/16"x 1 1/2" Bin Seal Gr. 8.2 Bolts, heads outside where Hopper Panels lap and attach to body section. 5/16" Hex Nuts inside .	24 24 24
14	39-45692 39-47493	Vertical Hopper Seams - Use a 3/8 x 1" Truss Head Bin Seal Gr. 8.2 Bolts, heads inside Bin, and Flange Nuts outside . Caulk* on both sides of the Bolt.	1026 1026
15	39-45692 39-47493	Horizontal Hopper Seams, Lower Hopper Panel to Upper - Use 3/8 x 1" Truss Head Bin Seal Gr. 8.2 Bolts, heads inside Bin, and Flange Nuts outside . Start with a Lower Hopper Seam exactly on the seam of an Upper Hopper Seam. Lower Panels go inside of Upper Panels. Caulk* on both sides of the Bolt.	168 168
16	39-20350 39-20152	Collar to Hopper - Use 5/16 x 1" Truss Head Bin Seal Gr. 8.2 Bolts, heads inside Bin, and Flange Nuts outside .	28 28
17	39-20132 39-20114	X-Brace to Legs and center hole - Use 3/8 x 1" Hex Head Gr. 8 Bolt and 3/8" Hex Nuts.	108 108
18		26 3/16" [664.6]	
19		42" [1 066]	
20		16" [406]	
21		42" [1 066]	
22		10" [254]	
23		Under Collar Clearance: 33 1/2" [851] for 16" [406] Collar 41 [1 041] for 25" [635] Collar	

21' [6 401] Diameter 45° Hopper Bin

* Sealant placement

○ Component
● Hardware

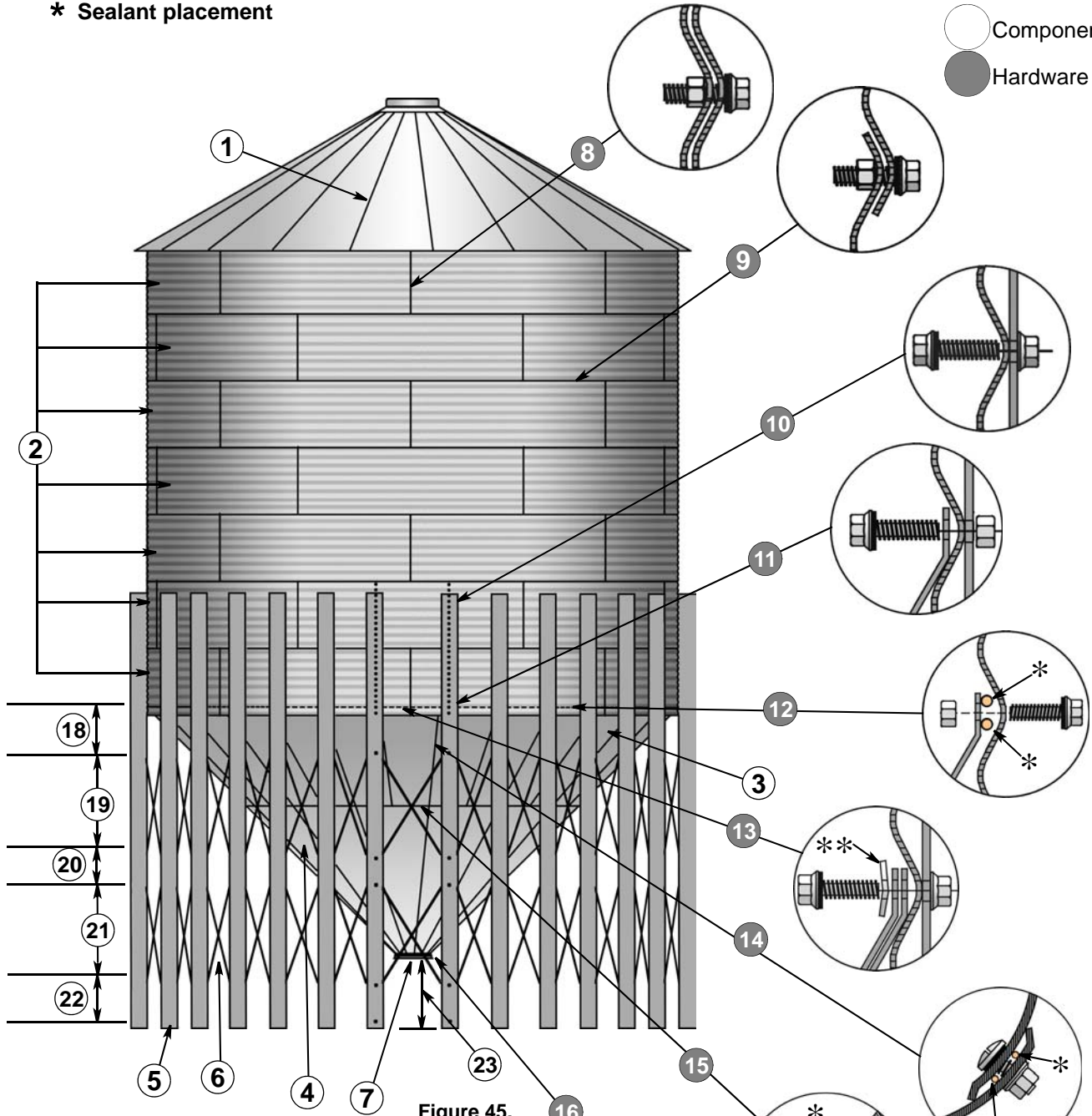

Figure 45.

BODY SHEET GAUGE CHART							
BODY SHEET RINGS	Model Numbers						
	02132	02133	02134	02135	02136	02137	02138
top	17	20	20	20	20	20	20
2	9	17	20	20	20	20	20
3		9	17	18	18	18	18
4			9	17	17	17	17
5				9	15	15	15
6					8	14	14
7						9	13
8							8

21' [6 401] Diameter 45° Hopper Bin

Item	Part No.	Description	Qty.
1	9-23882	21' [6 401] Raised Rib Roof Complete (3 panel, 30°) See the supplemental Roof Manual, MGB1496.	1
21' [6 401] Body Sheets - 7 sheets per ring			
2	9-11249	20 ga. (top/mid) 3-8 rings	
	9-14258	18 ga. (mid) 5-8 rings	
	9-12245	17 ga. (mid) 6-8 rings	
	3-33425	17 ga. (mid/3 Leg) 2-5 rings	
	9-28125	15 ga. (mid) 7-8 rings	
	3-33506	15 ga. (mid/3 Leg) 6 rings	
	9-11255	14 ga. (mid) 8 rings	
	3-33507	14 ga. (mid/4 Leg) 7 rings	
	3-33508	13 ga. (mid/4 Leg) 8 rings	
	3-33509	9 ga. (bottom/3 Leg) 2-5 rings	
	3-33510	9 ga. (bottom/4 Leg) 7 rings	
3-33511	8 ga. (bottom/3 Leg) 6 rings		
3-33512	8 ga. (bottom/4 Leg) 8 rings		
3	3-14217	Upper Hopper Panel - 12 ga.	28
4	3-16622	Lower Hopper Panel - Joggled 16" [406] - 14 ga.	14 or
	3-34975	Lower Hopper Panel - 25" [635] - 14 ga.	14
5	3-18520	Leg 208.625" [5 299] O.A. 10 ga.	21 (2-5R) or 28 (7R)
	3-33212	Leg 208.625" [5 299] O.A. 8 ga.	21 (6R) or 28 (8R)
6	3-33602	X-Brace (inside) 3 Legs/Body sheet, fluorescent green, 10 ga.	42 (2-6R)
	3-33603	X-Brace (outside) 3 Legs/Body sheet, fluorescent red, 10 ga.	42 (2-6R)
	3-32623	X-Braces (inside) 4 Legs/Body sheet, fluorescent green, 10 ga.	56 (7-8R)
	3-32624	X-Braces (outside) 4 Legs/Body sheet, fluorescent red, 10 ga.	56 (7-8R)
7	3-16892	16" [406] 45° Collar for Joggled Hopper	1
IMPORTANT: All Bolts MUST be tightened from the Nut side. See page 22.			
8	39-20073 39-20020	Vertical Body Seams - Use 5/16 x 1" Bin Seal Gr. 8.2 Bolts, heads outside Bin, and Hex Nuts inside .	varies varies
9	39-20073 39-20020	Horizontal Body Seams - Use 5/16 x 1" Hex Head Bin Seal Gr. 8.2 Bolts, heads outside Bin, and Hex Nuts inside .	varies varies
10	39-20130 39-20152	Leg Bolts - Use 5/16 x 1 1/2" Bin Seal Gr. 8.2 Bolts, heads inside Bin, and Flange Nuts outside . (See exception below, Key 11.)	483 (2-6R) 644 (7-8R)
11	39-20323 39-20114	Leg-to-Body-to-Hopper Bolt - Use 3/8 x 1 1/2" Hex Head Bin Seal Gr. 8.2 Bolt, heads inside Bin, and Hex Nuts outside .	21 (2-6R) 28 (7-8R)
12	39-20130 39-20020	Upper Hopper Panels to Body Sections - Use 5/16 x 1 1/2" Bin Seal Gr. 8.2 Bolts and Hex Nuts. Start center of first Hopper Panel on a set of Leg holes.	399 (2-6R) 378 (7-8R)
13	39-20130 39-20074 39-20020	Use a 12 ga. Curved Washer** inside on 5/16"x 1 1/2" Bin Seal Gr. 8.2 Bolts, heads outside where Hopper Panels lap and attach to Body section. 5/16" Hex Nuts inside .	28 28 28
14	39-45692 39-47493	Vertical Hopper Seams - Use 3/8 x 1" Truss Head Bin Seal Gr. 8.2 Bolts, heads inside Bin, and Flange Nuts outside . Caulk* on both sides of the Bolt.	1554 1554
15	39-45692 39-47493	Horizontal Hopper Seams, Lower Hopper Panel to Upper - Use 3/8 x 1" Truss Head Bin Seal Gr. 8.2 Bolts, heads inside Bin, and Flange Nuts outside . Start with a Lower Hopper Seam exactly halfway between the Seam of an Upper Hopper Panel. Lower Panels go inside of Upper Panels. Caulk* on both sides of the Bolt.	168 168
16	39-20350 39-20152	Collar to Hopper - Use 5/16 x 1" Truss Head Bin Seal Gr. 8.2 Bolts, heads inside Bin, and Flange Nuts outside .	28 28
17	39-20132 39-20114	X-Brace to Legs and center hole - Use 3/8 x 1" Hex Head Gr. 8 Bolt and 3/8" Hex Nuts.	126 (2-6R) 168 (7-8R)
18		35 11/16" [905.9]	
19		42" [1 066]	
20		21" [533]	
21		42" [1 066]	
22		14" [356]	
23		Under Collar Clearance: 32 5/8" [829] for 16" [406] Collar 40" [1 016] for 25" [635] Collar	

This page intentionally left blank.

This page intentionally left blank.



DIFFERENT BY DESIGN®

BROCK GRAIN SYSTEMS
A Division of CTB Inc.

P.O. Box 2000 • Milford, Indiana 46542-2000 • U.S.A.
Phone (574) 658-4191 • Fax (574) 658-4133
e-mail: brock@brockgrain.com • Internet: <http://www.brockgrain.com>

Printed in the U.S.A.

All specifications subject to change without notice.

Changes this issue:

Foot weldment used on some models now requires Octagon Washer instead of Heavy Washer.
Anchor information was updated.

Changes last issue:

Page 30: A 16" [406] Reinforced Collar is required when a Twin Upper Boot is used.
Pages 36 and 37: A Hopper Reinforcing Angle is now standard on all 12' 60° Hoppers.
There were miscellaneous corrections and additions.

NOTE: The original, authoritative version of this Manual is the [English] version produced by CTB, Inc. or any of its subsidiaries or divisions, (hereafter collectively referred to as "CTB"). Subsequent changes to any Manual made by any third party have not been reviewed nor authenticated by CTB. Such changes may include, but are not limited to, translation into languages other than [English], and additions to or deletions from the original content. CTB disclaims responsibility for any and all damages, injuries, Warranty claims and/or any other claims associated with such changes, inasmuch as such changes result in content that is different from the authoritative CTB-published [English] version of the Manual. For current product installation and operation information, please contact the Customer Service and/or Technical Service Departments of the appropriate CTB subsidiary or division. Should you observe any questionable content in any Manual, please notify CTB immediately in writing to: CTB Legal Department, P.O. Box 2000, Milford, IN 46542-2000 USA.