

C2 Plus End Control Proximity Sensor Retro-Fit Kit Installation Instruction

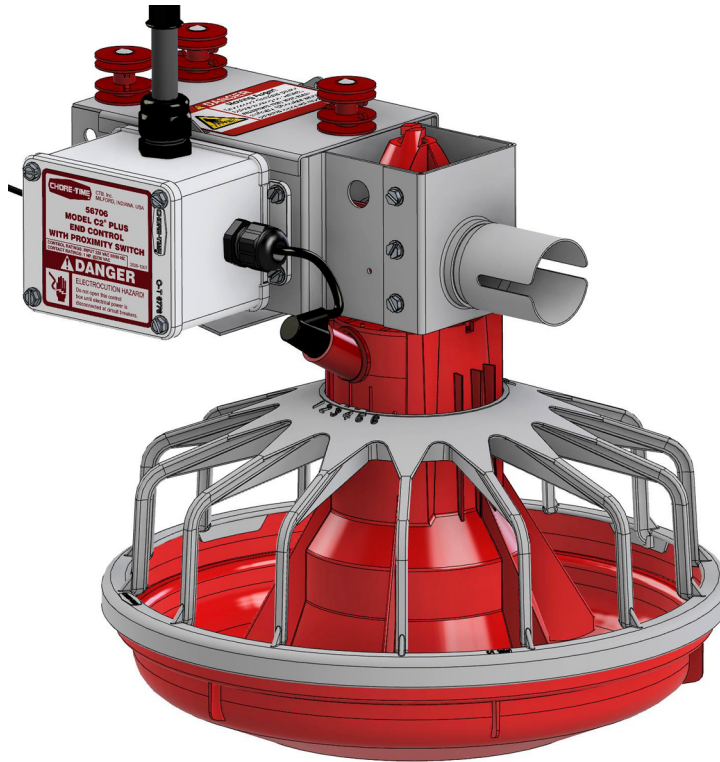

For additional parts and information, contact your nearest Chore-Time distributor or representative.
Find your nearest distributor at: www.choretime.com/contacts

CTB, Inc.
PO Box 2000
Milford, Indiana 46542-2000 USA
Phone (574) 658-4101 Fax (877) 730-8825
Email: choretime@choretime.com
Internet: www.choretime.com

Step 1. Remove (4x) Screws (**Item 1**) from the Control Body. Keep them for re-assembly. Loosen the Water-tight Connector (**Item 2**). Cut the old sensor wire when needed to remove components when it gets in the way.

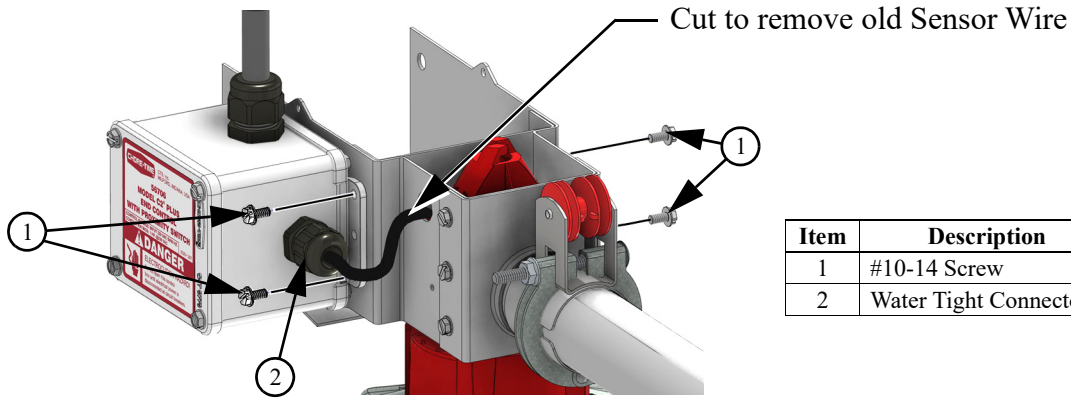

Item	Description
1	#10-14 Screw
2	Water Tight Connector

Step 2. Remove x2 Screws (**Item 1**) to remove the Feed Chute (**Item 2**). Slide the Center Divider (**Item 3**) off the Feed Tube.

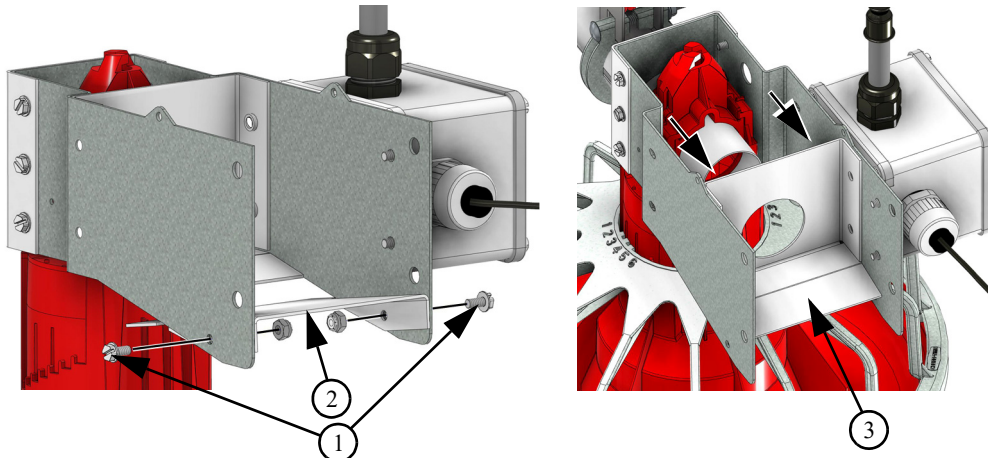

Item	Description
1	#10-24 Screw
2	Feed Chute
3	Center Divider

Step 3. Loosen x4 Screws (**Item 1**) (bottom 2 Screws on each side. Top one does not need to be loosened) until end is flush with wall so that the cone is free to move.

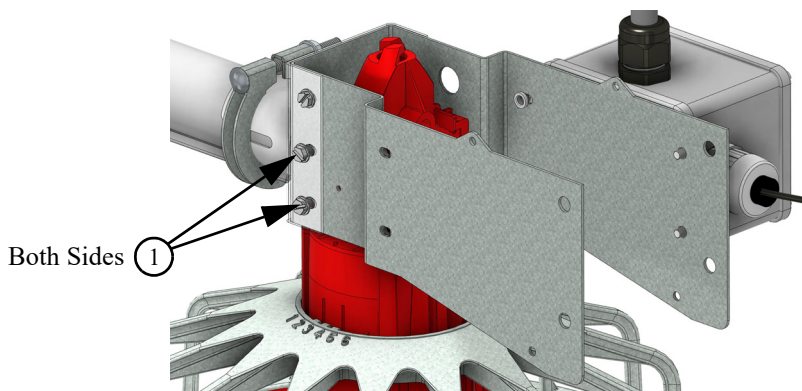

Item	Description
1	#10-24 Screw

Step 4. Slide the Cone off of the Rigid Tube and out over the Auger. Use side cutters to cut the Cone top off. Remove the old Cone/Grill/Pan assembly.

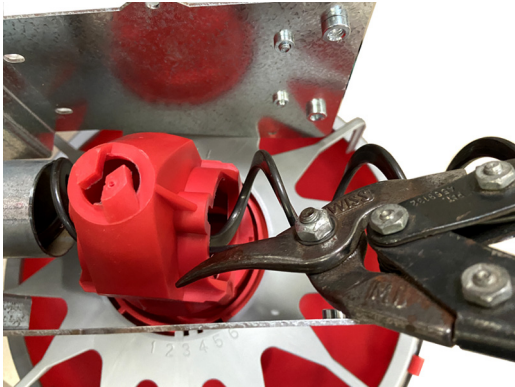

Step 5. Slid the new Cone/Grill/Pan assembly on to the Stub Tube (**Item 1**) as shown, and slide the new Top (**Item 2**) into place. ENSURE HOLE IN NEW CONE IS ON THE SAME SIDE AS THE WHITE RELAY BOX BEFORE MOVING ON!!!!

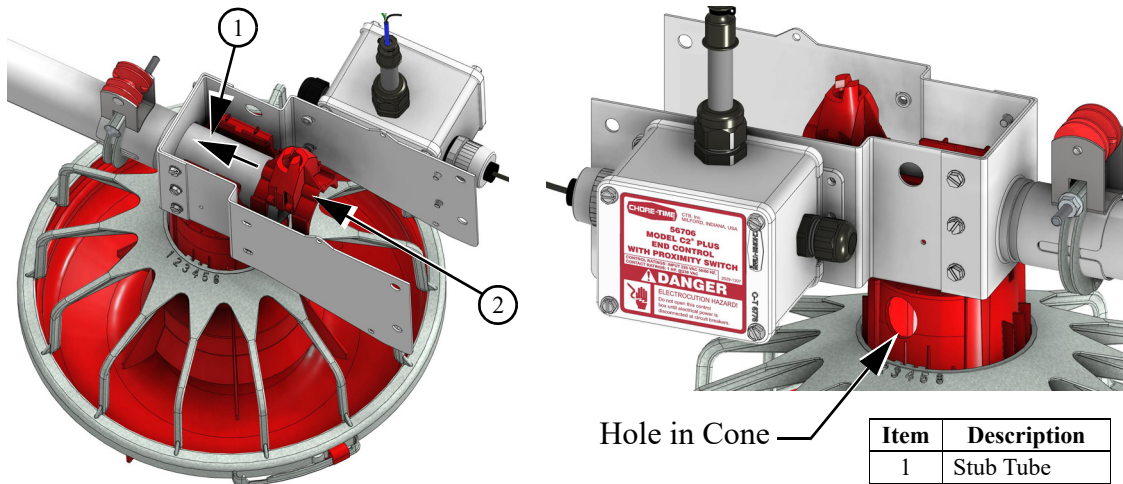

Item	Description
1	Stub Tube
2	New Top

Step 6. Tighten bottom two Screws on each side, re-attach Feed Chute, and re-install the Center Divider with the Hardware removed in Steps 1 through 3.

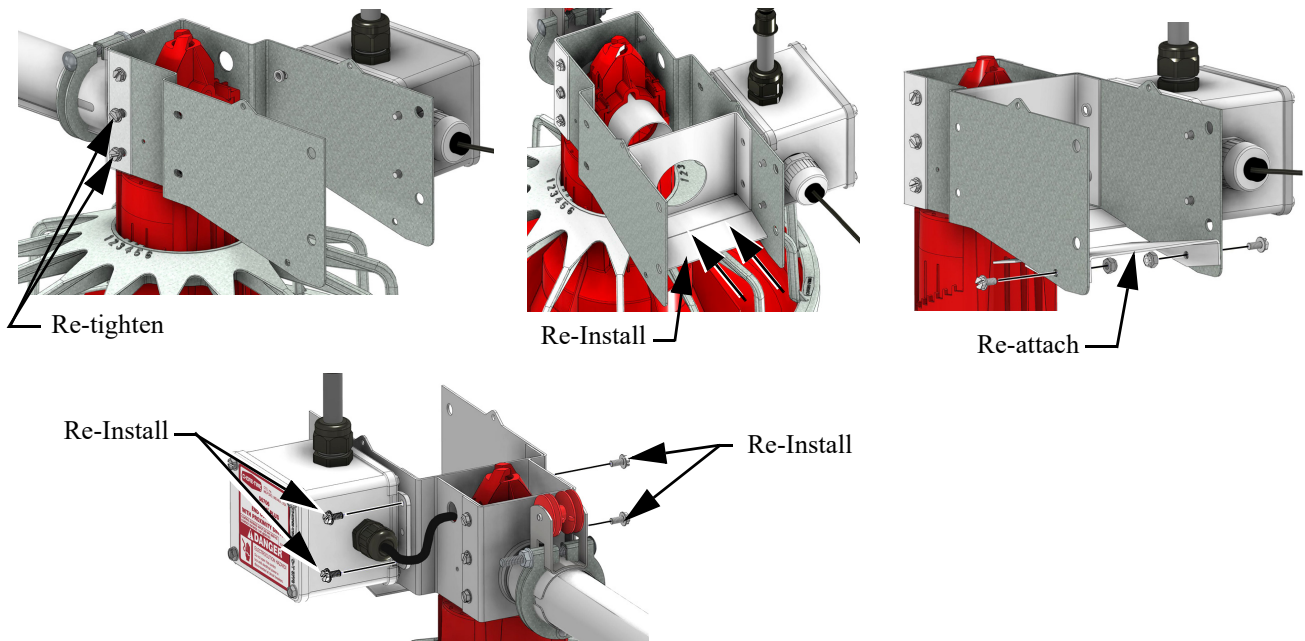

Step 7. Remove (4x) Screws (**Item 1**) and the Relay Box Cover (**Item 2**) as shown. Loosen the Watertight Connector (**Item 3**).

Item	Description
1	#10-14 Screw
2	Relay Box Cover
3	Water Tight Connector

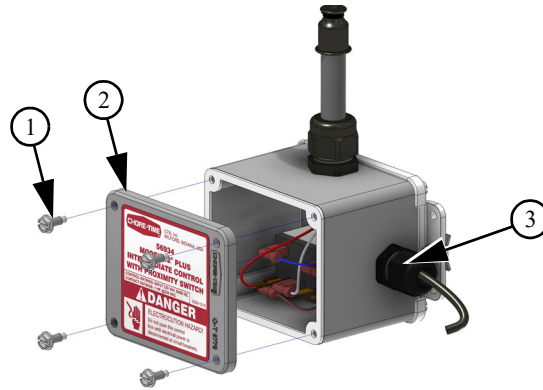

Step 8. Take note of the location of the old Sensor Wire Leads. The new Proximity Sensor will be wired exactly the same way. Cut the old Black Sensor Wire near the Cone and remove the old Wire and the Sensor.

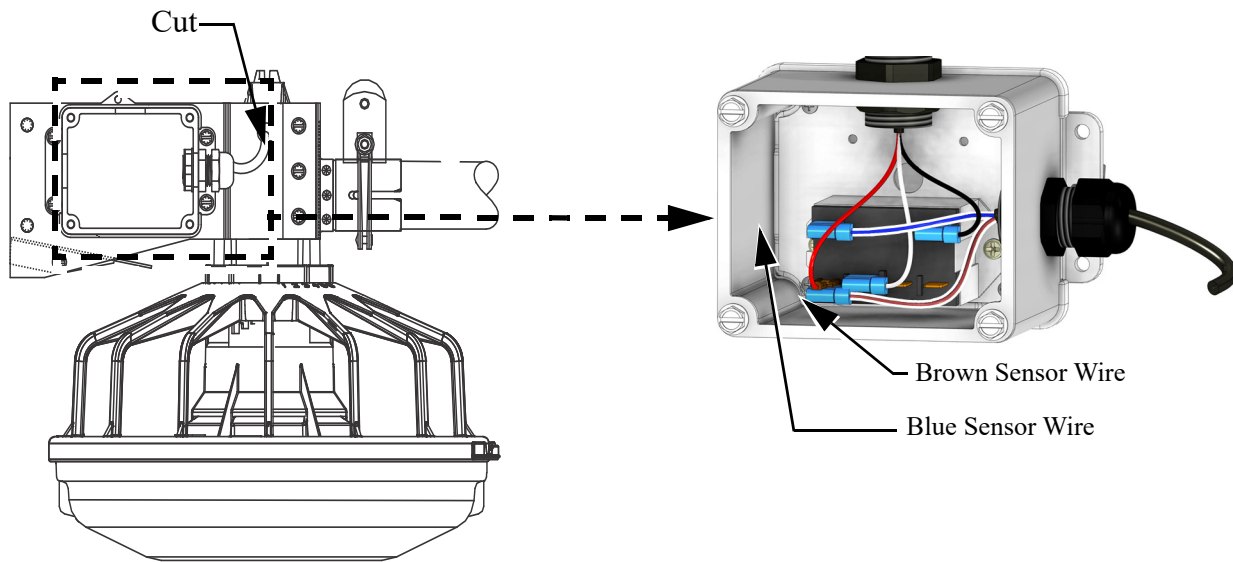

Step 9. Slide supplied Vinyl Tubing (**Item 1**) over the new Sensor Wire, then thread new Sensor Wires through the Watertight Connector (**do this before crimping the 90 deg terminals onto the sensor leads**). Crimp 90 degree terminals onto the new Sensor Wire Leads. Place the new Brown and Blue Sensor Leads in the same position they were in the old Box (**See Step 2**). Tighten Relay Box Watertight Connector.

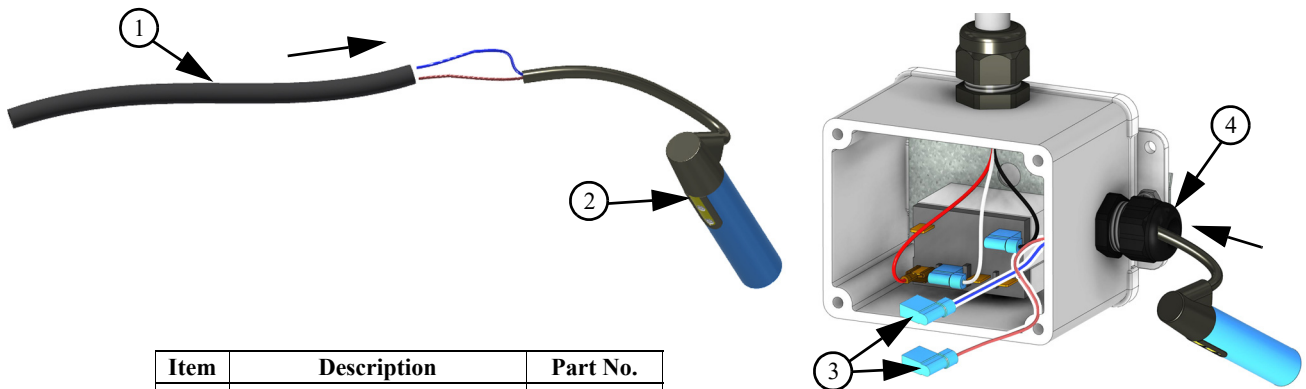

Item	Description	Part No.
1	.25 Vinyl Tubing (Included)	14454-2
2	New Proximity Sensor	56275
3	90° Terminals	56281
4	Water Tight Connector	--

Step 10. Ensure that the bottom of Sensor Holder (**Item 1**) is flush on the bottom, then use an upward motion to snap the top of the Sensor holder in place.

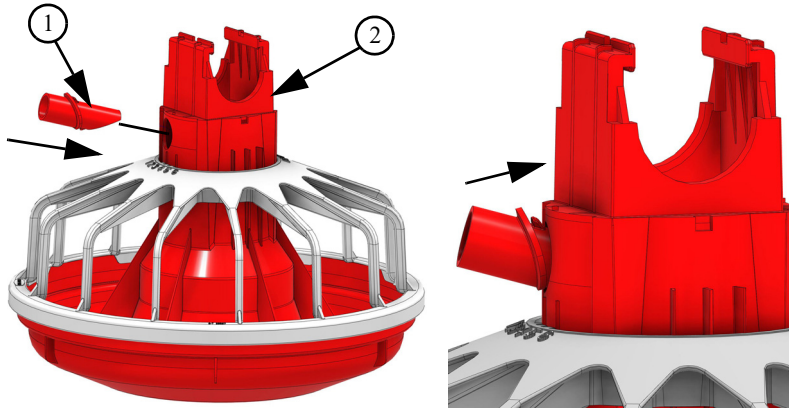

Item	Description	Part No.
1	Sensor Holder	56768
2	New Cone	56767

Step 11. Place Sensor (**Item 1**) in the Sensor Holder (**Item 2**). Make sure the wire outlet from the Sensor is facing up. This will keep the wire away from birds and prevent birds getting caught.

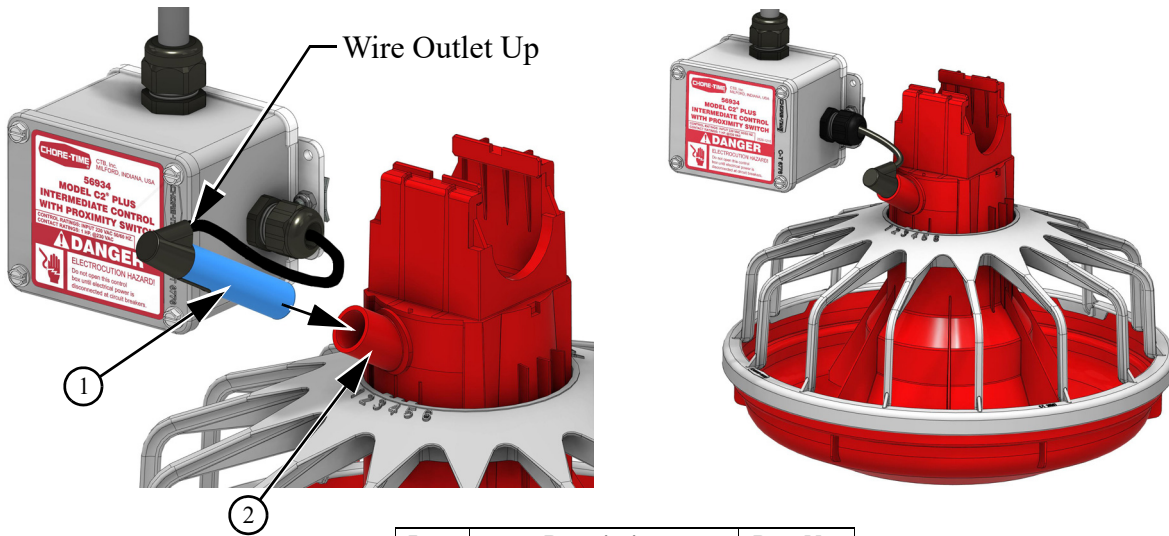

Item	Description	Part No.
1	Proximity Sensor	56275
2	Sensor Holder	--



**MADE TO WORK.
BUILT TO LAST.®**

Revisions to this Manual

Page No.	Description of Change	ECO
	New Manual	35220

**For additional parts and information, contact your nearest Chore-Time distributor or representative.
Find your nearest distributor at: www.choretime.com/contacts**

CTB, Inc.
PO Box 2000
Milford, Indiana 46542-2000 USA
Phone (574) 658-4101 Fax (877) 730-8825
Email: choretime@choretime.com
Internet: www.choretime.com