

CHORE-TIME[®]

Poultry Production Systems

**MODEL C2[®] PLUS & MODEL G[™] PLUS
with Electronic Sensor (ES) Feeding System**

Installation and Operators Manual



Installation and Operators Manual

Installation and Operators Manual

Chore-Time Warranty

Chore-Time Group, a division of CTB, Inc. (“Chore-Time”) warrants the new CHORE-TIME MODEL C2® AND G™ PLUS Feeding System with Electronic Sensor manufactured by Chore-Time to be free from defects in material or workmanship under normal usage and conditions, for One (1) year from the date of installation by the original purchaser (“Warranty”). Chore-Time provides for an extension of the aforementioned Warranty period (“Extended Warranty Period”) with respect to certain Product parts (“Component Part”) as set forth in the table below. If such a defect is determined by Chore-Time to exist within the applicable period, Chore-Time will, at its option, (a) repair the Product or Component Part free of charge, F.O.B. the factory of manufacture or (b) replace the Product or Component Part free of charge, F.O.B. the factory of manufacture. This Warranty is not transferable, and applies only to the original purchaser of the Product.

Product	Time Period from Installation	Charge to be paid by the purchaser for replacement
Feeder Pans	0 - 3 years	No Charge
	3-4 years	4/10 of then current list price
	4-5 years	5/10 of then current list price
Rotating Centerless Augers excluding applications involving high moisture feed stuffs (exceeding 18%)	10 years	No Charge
Chore-Time manufactured roll formed steel auger tubes	10 years	No Charge

CONDITIONS AND LIMITATIONS

THIS WARRANTY CONSTITUTES CHORE-TIME’S ENTIRE AND SOLE WARRANTY AND CHORE-TIME EXPRESSLY DISCLAIMS ANY AND ALL OTHER WARRANTIES, INCLUDING, BUT NOT LIMITED TO, EXPRESS AND IMPLIED WARRANTIES, INCLUDING, WITHOUT LIMITATION, WARRANTIES AS TO MERCHANTABILITY OR FITNESS FOR PARTICULAR PURPOSES. CHORE-TIME shall not be liable for any direct, indirect, incidental, consequential or special damages which any purchaser may suffer or claim to suffer as a result of any defect in the Product. Consequential or Special Damages as used herein include, but are not limited to, lost or damaged products or goods, costs of transportation, lost sales, lost orders, lost income, increased overhead, labor and incidental costs, and operational inefficiencies. *Some jurisdictions prohibit limitations on implied warranties and/or the exclusion or limitation of such damages, so these limitations and exclusions may not apply to you. This warranty gives the original purchaser specific legal rights. You may also have other rights based upon your specific jurisdiction.*

Compliance with federal, state and local rules which apply to the location, installation and use of the Product are the responsibility of the original purchaser, and CHORE-TIME shall not be liable for any damages which may result from non-compliance with such rules.

The following circumstances shall render this Warranty void:

- Modifications made to the Product not specifically delineated in the Product manual.
- Product not installed and/or operated in accordance with the instructions published by the CHORE-TIME.
- All components of the Product are not original equipment supplied by CHORE-TIME.
- Product was not purchased from and/or installed by a CHORE-TIME authorized distributor or certified representative.
- Product experienced malfunction or failure resulting from misuse, abuse, mismanagement, negligence, alteration, accident, or lack of proper maintenance, or from lightning strikes, electrical power surges or interruption of electricity.
- Product experienced corrosion, material deterioration and/or equipment malfunction caused by or consistent with the application of chemicals, minerals, sediments or other foreign elements.
- Product was used for any purpose other than for the care of poultry and livestock.

The Warranty and Extended Warranty may only be modified in writing by an officer of CHORE-TIME. CHORE-TIME shall have no obligation or responsibility for any representations or warranties made by or on behalf of any distributor, dealer, agent or certified representative.

Effective: **January 2014**

Contents

Topic	Page
Chore-Time Warranty	2
Manufacturer's Recommendations: Birds per Pan	5
About This Manual	6
Safety Information	6
Safety Instructions	7
Follow Safety Instructions	7
Decal Descriptions	7
DANGER: Moving Auger	7
DANGER: Electrical Hazard	7
CAUTION:	7
General	7
Support Information	7
Planning the Suspension System	8
General Installation Information	9
Laying out the Suspension System	9
Installing the Suspension System	10
Power Lift Winch Installation	10
Installing the Main Winch Cable	11
Screw Hook Installation	12
Ceiling Hook Installation	13
Drop Installation	14
Hopper Assembly Procedure	15
Assembly	15
Suspend the Hopper	15
Feeder pan assembly	16
Feeder Line Assembly and Suspension	16
Feeder Pan and Tube Assembly Process	16
Assemble and Suspend the Feeder Line	16
Installing the End Control, Boot Assembly, and Auger	19
Auger Installation	19
Auger Installation	23
Auger Brazing	26
Mid-Line Control	27
Anti-Roost Assembly	29
Wiring	32
End Control with Electronic Sensor (ES) Internal Wiring	32
Electronic Sensor Control Wiring Diagram	32
Mid Control with Electronic Sensor (ES) Internal Wiring	32
Mechanical Switch Single Phase(Ø) Wiring Diagram	33
Mechanical Switch Single Phase(Ø) Wiring Diagram with Motor Starter	33
Mechanical Switch Three Phase(Ø) Wiring Diagram: 220 V.	34
Mechanical Switch Three Phase(Ø) Wiring Diagram: 380/415 V.	34
Electronic Sensor Three Phase (Ø) Wiring	35

Contents - continued

Topic	Page
Troubleshooting	36
Maintenance	37
Floor Feeding System Maintenance	37
Gear Head Maintenance	37
Mechanical Switch Adjustment procedure for Control Units	38
Electronic Sensor Adjustment for Control Units	38
Feeder Line	39
Power Lift Winch Maintenance	39
Management	40
Initial Start-up of the Feeding System	40
General Operation of the MODEL C2® PLUS and MODEL G™ PLUS Feeders	41
End Control and Mid Line Control Pans	42
Controlling the Feeders (optional equipment)	42
Electro-guard Operation	42
Parts List	43
150# Plastic Hopper	43
200# Hopper Components	44
100 # Hopper Components	45
Hopper Mount Bracket (Optional)	46
Single Boot Components Part No. 6822	46
Twin Boot Components Part No. 6824	47
Feeder Line Components	48
C2 PLUS Standard with Two Piece Top	49
C2 PLUS Standard with One Piece Top	49
MODEL C2 PLUS Shallow with Two Piece Top	50
C2 PLUS Shallow with One Piece Top	50
MODEL C2 PLUS and G PLUS with Extended Fins	51
MODEL G PLUS Standard with Two Piece Top	52
MODEL G PLUS Standard with One Piece Top	52
MODEL G PLUS Shallow with Two Piece Top	53
MODEL G PLUS Shallow with Two Piece Top	53
Power Unit Assemblies	54
Power Unit Assembly Part Numbers:	54
Mechanical End Control	55
Mechanical Mid Line Control	57
Electronic Sensor End Control	59
Electronic Sensor Mid Line Control	61
MODEL G PLUS Pan Extension (Optional)	62
2883 Power Winch	62
Miscellaneous Suspension Components	63

Manufacturer's Recommendations: Birds per Pan

Type	Max weight and/or weeks of age	Feeders	Number of birds/pan
Broiler	4.5 lbs/2 kg.	Revolution 12, Models C2 PLUS, Liberty, C2 PLUS S, C, H2™, H2™ PLUS	60 - 90
Broiler	6 lbs/2.7 kg	Revolution 8 & 12, C2 PLUS, C2 PLUS S, G PLUS, G PLUS S, C, Liberty, H2, H2 PLUS	55 - 80
Broiler	7 lbs/3.1 kg	Revolution 8 & 12, C2 PLUS, C2 PLUS S, G PLUS, G PLUS S, C, Liberty, H2, H2 PLUS	55 - 75
Broiler	9 lbs/4.0 kg	Revolution 8, G PLUS, G PLUS S Liberty	45 - 65
Broiler Breeder Pullet – rearing	0 – 18 weeks	C2 PLUS (Breeder), C2 PLUS S (Breeder)	14 - 15
Broiler Breeder Pullet – rearing	0 – 18 weeks Hi-Yield	C2 PLUS (Breeder), C2 PLUS S (Breeder)	12-14
Broiler Breeder Male – rearing	0 -- 18 weeks	C2 PLUS (Breeder), C2 PLUS S (Breeder), G PLUS (Breeder), G PLUS S (Breeder)	11-13
Broiler Breeder Layer	17 + weeks	C2 PLUS (Breeder), C2 PLUS S (Breeder)	13 - 14
Broiler Breeder Layer	17 + weeks Hi-Yield	C2 PLUS (Breeder), C2 PLUS S (Breeder)	12 - 13
Broiler Breeder Male	17 + weeks	Revolution 8, G PLUS (Breeder), G PLUS S (Breeder)	8-10
Commercial Layer Pullet – rearing	0 – 20 weeks	Revolution 12, C2 PLUS, H2, H2 PLUS	40-60
Commercial Layer	18 + weeks	Revolution 12, C2 PLUS, C, H2, H2 PLUS	30 - 40
Turkey Poult	0 – 7 weeks	Revolution 8, H2 PLUS, H2, Liberty, G PLUS, G PLUS S	60 - 65
Turkey Hens	0 – 12 weeks	Revolution 8, G PLUS, H2 PLUS, Liberty, H2	40 - 50
Turkey Female	5 + weeks	ATF, ATF PLUS	60
Turkey Male	5 + weeks	ATF, ATF PLUS	40 - 50
Ducks	0 – 3 weeks	G PLUS, G PLUS S	60 - 70
Ducks	4 – 8 weeks	G PLUS, G PLUS S	50 - 60

***Notice:** Please be advised that the maximum number of birds that may be successfully produced per feed pan may vary based upon such factors as climate, housing type or style, bird breeds, genetic factors of the birds at issue, grower management practices, etc. All other environmental and management circumstances, such as proper bird density per house, access to adequate nutrients in feed, access to adequate water supply, proper ventilation, adequate health care for the birds, and other similar factors, must meet industry standards and recommendations, if any, of applicable bird breeder companies.

*** NOTICE:** The above Manufacturer's recommendations do not constitute a product warranty and are in no way to be considered as a guarantee of performance for poultry production. In addition, the above information in no way alters or revises the terms and conditions of any applicable Chore-Time manufacturer's warranty.

About This Manual

The intent of this manual is to help you in two ways. One is to follow step-by-step in the order of assembly of your product. The other way is for easy reference if you have questions in a particular area.

Important: Read **ALL** instructions carefully before starting construction.

Important: Pay particular attention to all **SAFETY** information.

- *Metric measurements are shown in millimeters and in brackets, unless otherwise specified. “ ” equals inches and “ ’ ” equals feet in English measurements.*

Examples:

1" [25.4]

4' [1 219]

- Optional equipment contains necessary instructions for assembly or operation.
- Very small numbers near an illustration (*i.e.*, 1257-48) are identification of the graphic, not a part number.

Note: The original, authoritative version of this manual is the English version produced by CTB, Inc. or any of its subsidiaries or divisions, (hereafter collectively referred to as "CTB"). Subsequent changes to any manual made by any third party have not been reviewed nor authenticated by CTB. Such changes may include, but are not limited to, translation into languages other than English, and additions to or deletions from the original content. CTB disclaims responsibility for any and all damages, injuries, warranty claims and/or any other claims associated with such changes, inasmuch as such changes result in content that is different from the authoritative CTB-published English version of the manual. For current product installation and operation information, please contact the customer service and/or technical service departments of the appropriate CTB subsidiary or division. Should you observe any questionable content in any manual, please notify CTB immediately in writing to: CTB Legal Department, P.O. Box 2000, Milford, IN 46542-2000 USA.

Safety Information

Caution, Warning and Danger Decals have been placed on the equipment to warn of potentially dangerous situations. Care should be taken to keep this information intact and easy to read at all times. Replace missing or damaged safety decals immediately.

Using the equipment for purposes other than specified in this manual may cause personal injury and/or damage to the equipment.

Safety–Alert Symbol



This is a safety–alert symbol. When you see this symbol on your equipment, be alert to the potential for personal injury. This equipment is designed to be installed and operated as safely as possible...however, hazards do exist.

Understanding Signal Words

Signal words are used in conjunction with the safety–alert symbol to identify the severity of the warning.



DANGER indicates an imminently hazardous situation which, if not avoided, **WILL** result in death or serious injury.



WARNING indicates a potentially hazardous situation which, if not avoided, **COULD** result in death or serious injury.



CAUTION indicates a hazardous situation which, if not avoided, **MAY** result in minor or moderate injury.

Safety Instructions

Follow Safety Instructions

Carefully read all safety messages in this manual and on your equipment safety signs. Follow recommended precautions and safe operating practices.

Keep safety signs in good condition. Replace missing or damaged safety signs.

Decal Descriptions

DANGER: Moving Auger

This decal is placed on the Panel Weldment.

Severe personal injury will result, if the electrical power is not disconnected, prior to servicing the equipment.

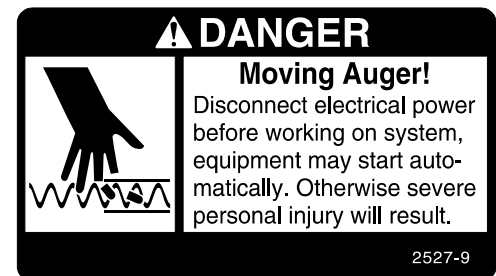

DANGER: Electrical Hazard

Disconnect electrical power before inspecting or servicing equipment unless maintenance instructions specifically state otherwise.

Ground all electrical equipment for safety.

All electrical wiring must be done by a qualified electrician in accordance with local and national electric codes.

Ground all non-current carrying metal parts to guard against electrical shock.

With the exception of motor overload protection, electrical disconnects and over current protection are not supplied with the equipment.

CAUTION:

Use caution when working with the Auger—springing Auger may cause personal injury.

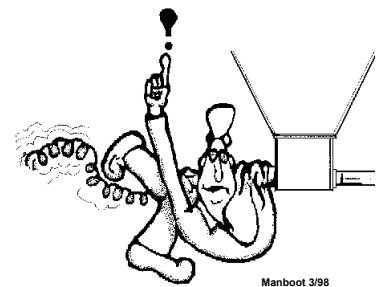
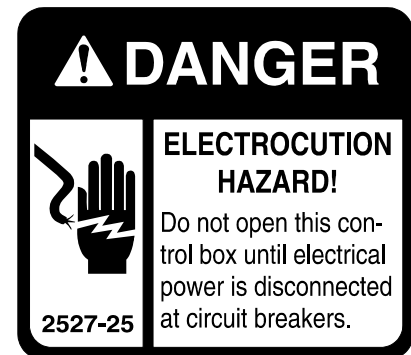

General

Support Information

The Chore-Time MODEL C2® PLUS and, MODEL G™ PLUS Feeding System's have been designed to feed poultry feed types. Using this equipment for any other purpose or in a way not within the operating recommendations specified in this manual will void the warranty and may cause personal injury.

This manual is designed to provide comprehensive planning and installation information. The Table of Contents provides a convenient overview of the information in this manual.

Planning the Suspension System

1. Select the House Layout.

A. Optional Mid Line Controls may be used for partial house brooding. See .

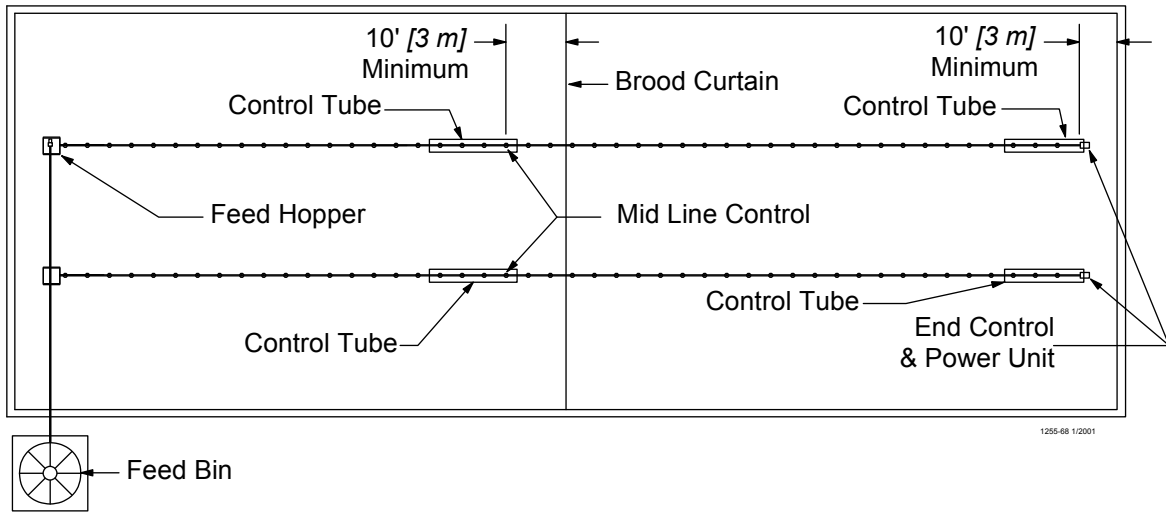

Figure 1. Component location diagram for systems up to 400 feet [122 m]. (Top View).

B. Systems with line lengths over 400' [122 m] should be split in the center, as shown in 2. This will reduce auger running time and eliminate the need for Mid-Line Controls for partial house brooding.

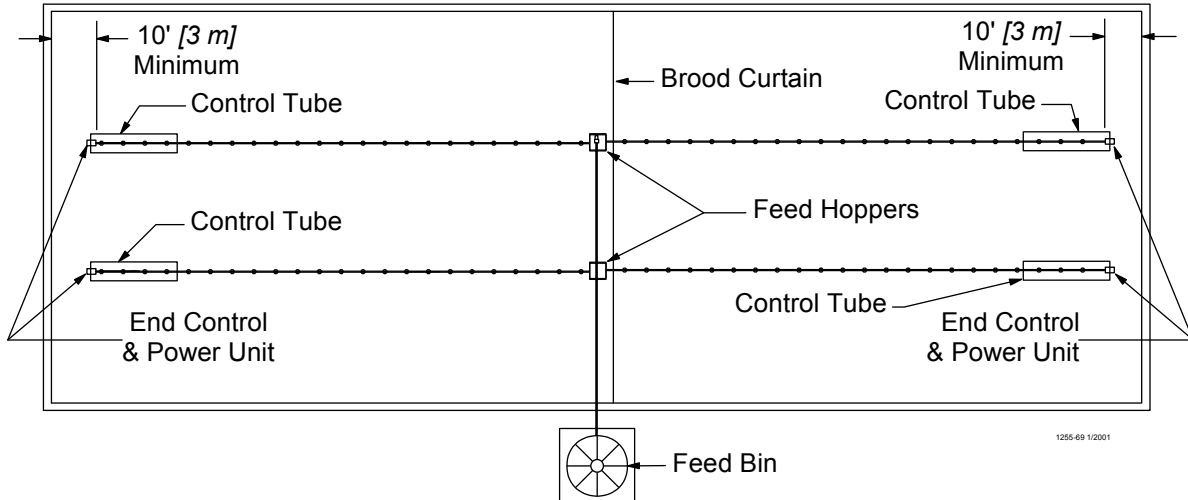

Figure 2. Component location diagram for systems over 400 feet [122 m]. (Top View).

2. Determine the Feed Bin location.
3. Determine the Brood Curtain location.
4. Determine the location for the End Control Pans, and if used the Mid Line Control Pans. **The Feeder Control Pans should be at least 10' [3 m] from the Wall or Brood Curtain.**
5. Determine the distance to the Feeder Line from the Side Wall.
6. Determine the distance from the Feed Hoppers to the End Wall for a Straight Line Feeding System.

General Installation Information

Please read the installation instructions in this manual prior to beginning the installation. This manual provides the necessary information on the installation, operation, and maintenance of the Chore-Time feeding equipment you have purchased.

The suspension, hopper assembly, feeder line installation, and anti-roost installation is the same for each system, except where noted otherwise. Please pay particularly close attention to insure proper assembly and installation of the equipment.

The MODEL C2® PLUS and G™ PLUS Control Units use a 348 RPM Gearhead, delivering approximately 17 lbs [7.7 kg] per minute. This rating is based on feed with a density of 40 lbs per cubic foot [640 kg per cubic meter].

Single phase 60 Hz and single and three phase 50 Hz Power Units are available for the MODEL C2 PLUS and G PLUS Feeders.

Systems up to 300' [91 m] require 1/3 HP. Power Units. Systems over 300' [91 m] require 1/2 HP. Power Units.

Laying out the Suspension System

1. Select the Suspension type.
 - A. For systems over 350' [107 m]

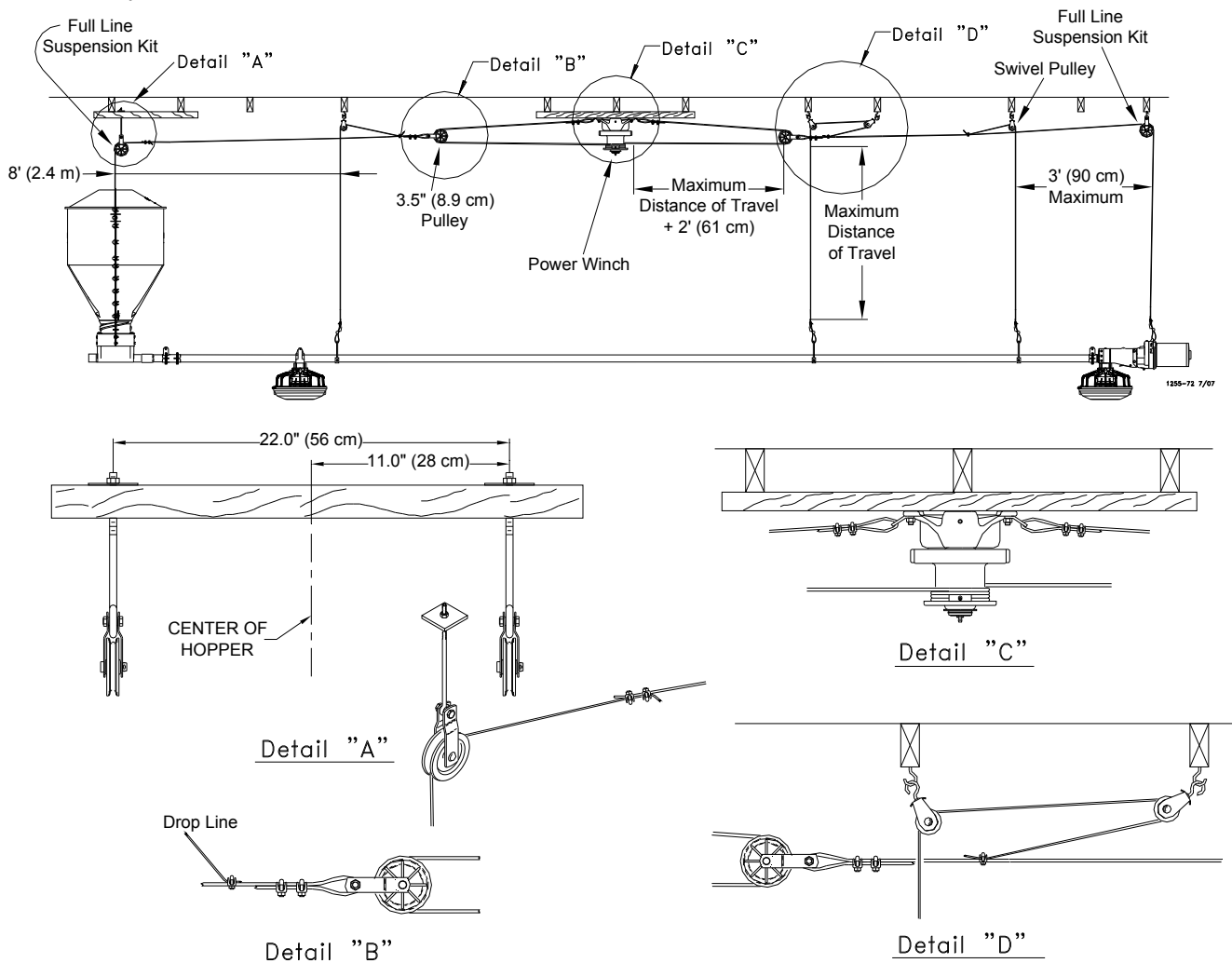

Figure 3. Suspension for systems over 350' [107 m]

B. For systems up to 350' [107 m]

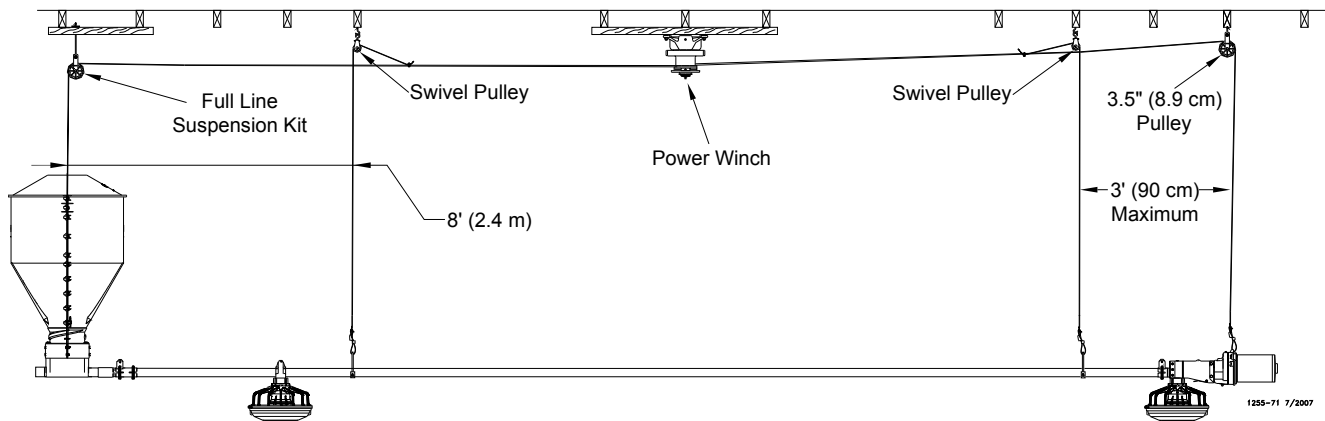

Figure 4. Suspension for systems up to 350' [107 m]

2. Locate the Power Lift Winch. The Power Lift Winch requires a support that will span, in a wood frame house at least 3 rafters, and in a steel frame house at least 2 rafters.
3. Locate the Power Unit and Feed Hopper. Special support is required at each Power Unit and Feed Hopper location.
4. Determine the Drop Location and length. Suspension systems are based on ceiling heights of 14' [4.3 m] with suspension drop points every 8' [2.4 m]. DO NOT EXCEED 10' [3 m] BETWEEN SUSPENSION DROPS.
5. Determine the location for Screw Hooks. Mark a straight line or use cable to locate Screw Hooks. Use the offset of Screw Hooks where necessary.

Installing the Suspension System

Power Lift Winch Installation

1. Bolt the Power Winch, fully assembled, to the Power Lift Winch Support, either a 2" x 8" [50x200 mm] board that will span at least 3 rafters or a 3/8" [9.5 mm] thick steel plate welded to two pieces angle iron that are each long enough to span at least 2 rafters, using 5/16-18 hardware supplied in the Hardware Package. The brake mechanism will extend toward one side.

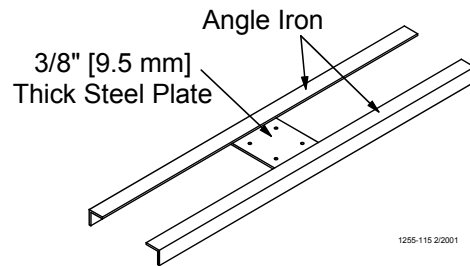

Figure 5. Optional Power Lift Winch support detail

Install a Cable Hook, supplied in Hardware Package, between the mounting bolt and Power Winch frame, as shown in **Figure 6**.

- Assembling the Power Winch to the Rafters
2. Attach the Power Lift Winch Support (with the Power Winch secured) to the ceiling at the center of the feeder line. See **Figure 7**. The Power Lift Winch Support must be parallel to the feeder line and must span at least 3 rafters in a wood frame house and 2 rafters in a steel frame house.

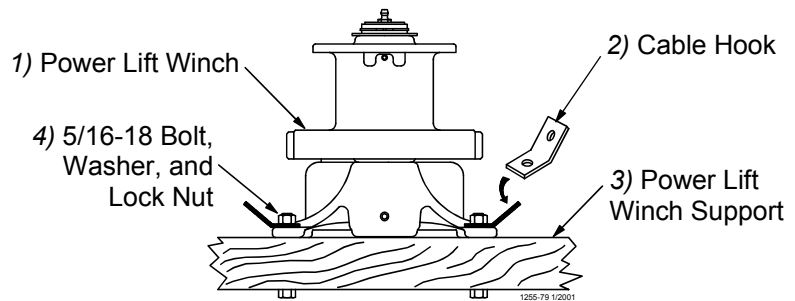

Figure 6. Assembling the Power Winch to the Rafters

note: If the hopper is located at the center of the feeder line, locate the Power Winch a few feet offset from the center of the feeder line. However, the Winch Drum must be directly in line with where the main cable is to be installed.

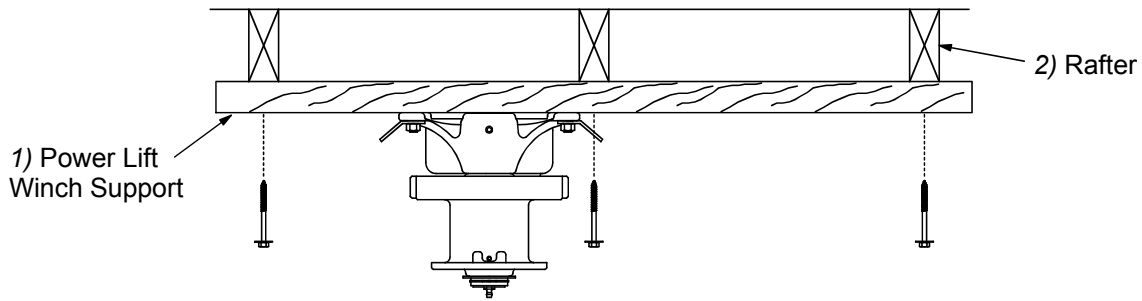

Figure 7. Mounting the Power Lift Winch and Support to the Rafters

Installing the Main Winch Cable

The Suspension Systems are based on ceiling heights of 14' [4.3 m] with Suspension Drop points every 8' [2.4 m]. DO NOT EXCEED 10' [3 m] BETWEEN SUSPENSION DROPS. Refer to suspension section in this manual for installation details.

Adequate overhead structure must be provided to support the weight of the feeders, hoppers, power units, etc. The Suspension System is the same for the Rev. 12 and 8 Feeders. The type of installation required depends on the feeder line length.

IMPORTANT: Special support is required at each Hopper location.

•Power Unit Locations: **The Feeder Line must be supported within 3' [0.9 m] of the Power Unit.** This is in addition to the required Power Unit suspension. If the Control Unit or Hopper does not come out directly under a truss, fasten a pulley to a 2" x 8" [50 x 200 mm] board or steel angle that will span 2 trusses and is capable of supporting 300 lbs [136 kg] for the Hopper and 75 lbs [34 kg] for the Control Unit.

•Feed Hopper Locations: **When steel hoppers with center suspension are used, see figure 8, the feeder line must be supported within 1' [30 cm] of the feed hopper.** When plastic hoppers are installed only 2 point suspension can be used, see figure 9, this does not require additional supports. See page 15 for plastic hopper suspension. This is in addition to the required Feeder Hopper suspension. After determining the type of suspension system required, decide where the Feeder Line is to be installed. Mark a straight line on the ceiling or rafters the full length of the Feeder Line. Use a string, chalk line, or the winch cable, temporarily attached with staples, to mark the line. Center the line directly over where the Feeder Line is to be installed.

- Extend the 3/16" [5 mm] Main Winch Cable the full length of the feeder line. Attach the cable temporarily to the ceiling with nails, staples, or some type of fasteners. **Figure 10** shows a double back arrangement for feed lines over 350' [107 m].

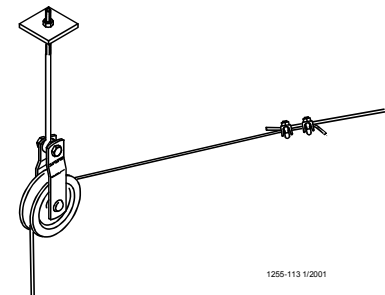

Figure 8. Steel Hopper Suspension

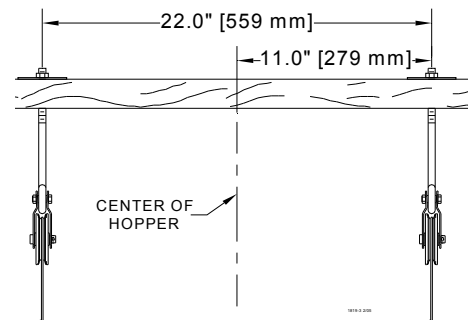

Figure 9. Plastic Hopper Suspension

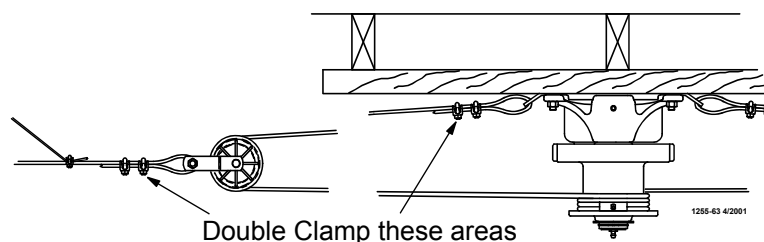

Figure 10. Double back arrangement for feed lines over 350' [107 m]

4. Route the cable through the Winch Drum Relief located near the bottom of the drum. Tighten the set screw to anchor the cable to the drum. See **Figure 11**.

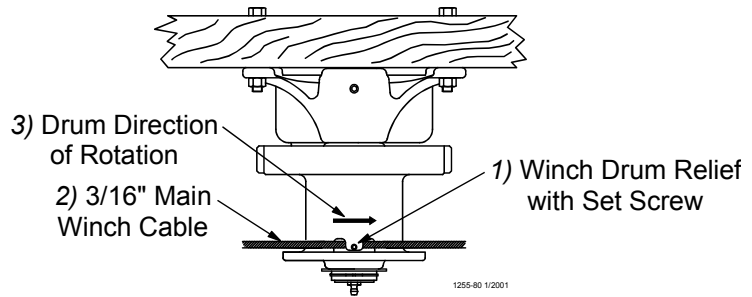

Figure 11. Attaching the Cable to the Power Winch

5. Turn the winch drum one full revolution. Guide the cable against the flange at the bottom of the winch drum. The cable must not wrap over itself on the drum, but should be wrapped as close as possible to each previous wrap. See **Figure 12**.

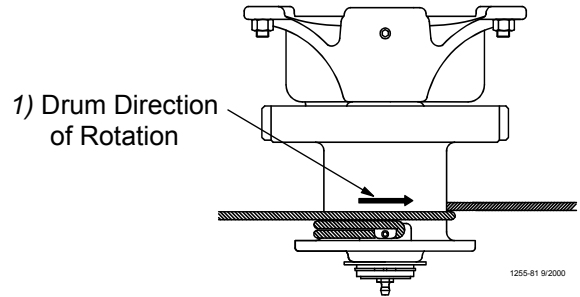

Figure 12. Power Winch Drum Rotation

Screw Hook Installation

The recommended distance between the drops for the feeder line is 8' [2.4 m] on center. Do not exceed 10' [3 m] spacing on drop lines.

If the distance raised is greater than the distance between the drop spacings, offset the hooks 3" [7.6 cm] to each side of the line to prevent the cable clamps from catching the pulleys, see **figure 13**.

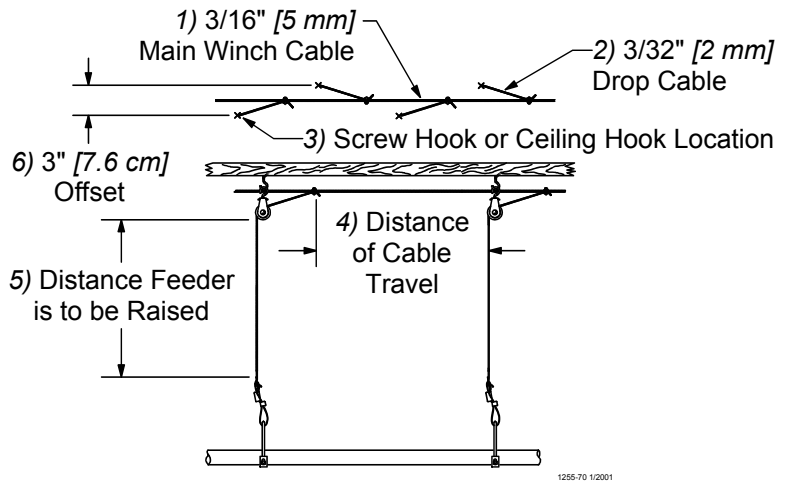

Figure 13. Drop Line Off Set Detail

Screw the hook into the truss the full length of the threads to prevent bending.

The openings of the screw hooks must be pointed away from the direction of travel when the Power Winch raises the feeder line. See **Figure 14**.

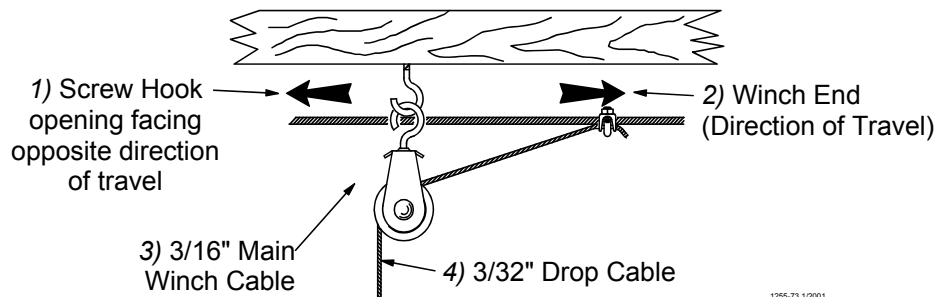

Figure 14. Screw Hook Installation

Ceiling Hook Installation

The ceiling hook may be used in a variety of installations. Depending on your ceiling or rafter type, install the Ceiling Hooks as shown in **Figures 15 - 19**.

Steel Truss Installations

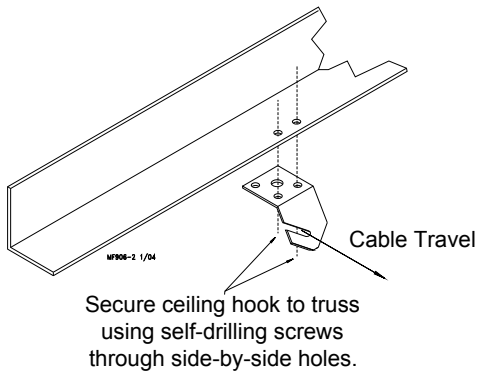

Figure 15. Narrow Steel Truss Installations

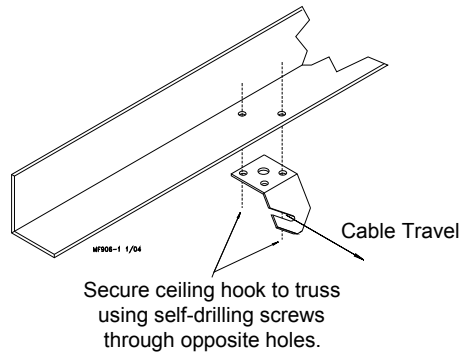

Figure 16. Wide Steel Truss Ceiling Installation

Steel Truss Welded Installations

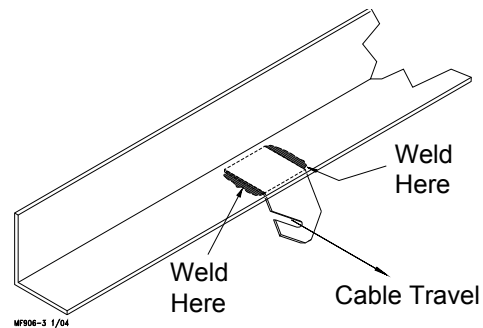

Figure 17. Welded Steel Truss Ceiling Bracket Installation

Wood Truss Installations

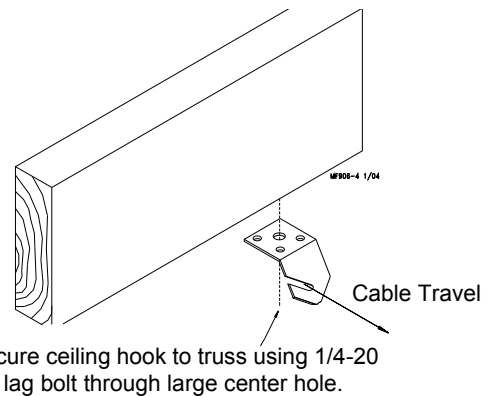

Figure 18. Wood Truss Ceiling Bracket Installation

6. After securing the Ceiling Hook to the truss, slide the hook of a Swivel Pulley into the slot, as shown in **Figure 19**.

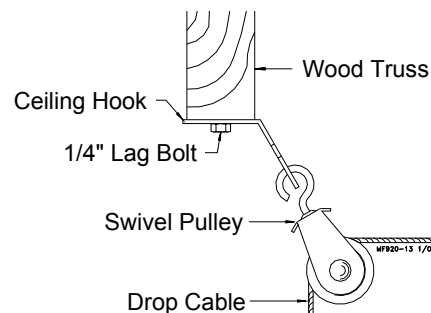

Figure 19. Pulley Installation

Drop Installation

Refer to **page 12 Figure 14**.

1. Attach a 3004 Pulley to each hook.
2. Thread the end of the 3/32" or 1/8" cable through the pulley toward the winch. Clamp this end to the 3/16" winch cable about 6" [150 mm] from the last pulley, using a 3/16" cable clamp. See applicable figure; **Figure 14 or 20**.
3. Allow enough cable length for installation of the Adjustment Leveler. Sufficient cable is included to provide "throwbacks" on drops located beneath and near the winch. **Figure 20** shows a "throwback" cable arrangement.

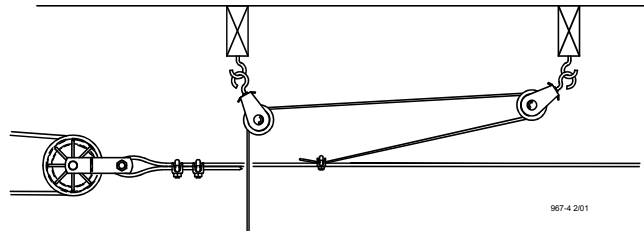

Figure 20. "Throwback" cable arrangement

4. **Begin installing suspension drops at the winch and proceed to the ends of the feeder line.** Keep the main cable tight between drops. It may be necessary to hang a weight on the end of the cable to maintain tension on the line.

Hopper Assembly Procedure

The 150 lb. Hopper Assembly is **NOT designed for single-point suspension**. The upper cross brace is designed for supporting the drop tube **ONLY**. This Hopper Assembly is to have **Two-point** suspension as stated.

Assembly

1. Assemble the 1/4-20 x 1-1/2" bolt to the brace with two 1/4-20 nuts. One nut should be assembled under the brace with the other on top. This bolt is to provide a place for the tube support assembly chain to be hooked, see **figure 21**.
2. Assemble the 150 lb. hopper halves and brace as shown in **Figure 21**, using #14 x 5/8" screws (supplied in hardware package).
3. Assemble the #8 x 1/2" screws and chain as shown in **Figure 21**.
4. Assemble suspension angles and suspension braces around feeder line boot (single or twin), using 1/4-20 x 1/2" Hex bolts and nuts (supplied in hardware package), see **figure 22**.

Note: The larger holes on the ends of the suspension angles need to be on the upper side of the assembly.

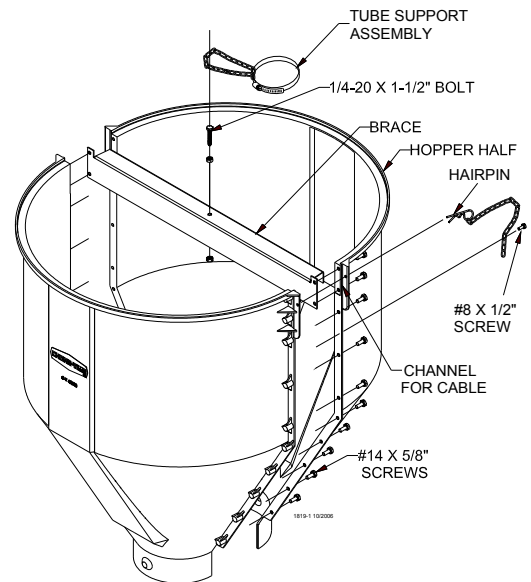

Figure 21.

5. Assemble the twist lock collar to the top of the feeder line boot (single or twin) using 1/4-20 x 1/2" bolts and lock nuts (supplied in hardware package), see **figure 22**.
6. Assemble the adjustment brackets to the suspension angles with 5/16-18 x 3/4" bolts and nuts (supplied in hardware package).
7. Two cable assemblies (cable with a sleeve clamp and a 5/32 thimble) are supplied with the suspension kit to support the hopper. Attach the cable assemblies to the adjustment brackets using the top holes of the adjustment brackets, see **figure 22**.

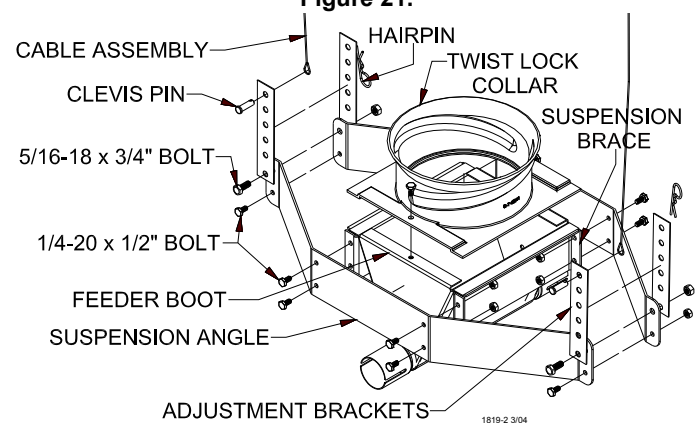

Figure 22.

8. Install two pulleys to either a 2" x 8" [50x200 mm] board that will span at least 3 rafters or a 3/8" [9.5 mm] thick steel plate welded to two pieces of angle iron that are long enough to span at least 2 rafters. Install the pulleys directly above the feeder line where the hopper is to be located. The pulleys should be spaced 22" [559 mm] apart (11" [279 mm] from the center of the hopper in both directions), see **figure 23**.

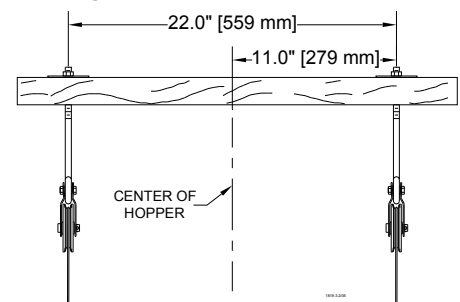
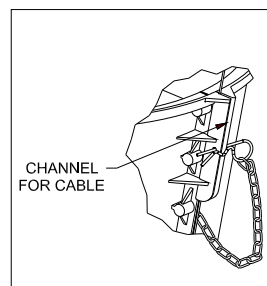

Figure 23.

Suspend the Hopper

1. Attach the boot to the feeder line.
2. Route the two cable assemblies up and around the pulleys.
3. Level the boot with the feed line and clamp the cables to the main cable using 1 cable clamp per cable assembly.
4. Place the hopper on top of the twist lock collar and rotate the hopper 90 degrees into position.

Make sure the cables lay in the channels on the sides of the hopper for support then use the hairpin to contain the cable.

Feeder pan assembly

All feeders assemble in the same manor. Refer to **Figure 24.** below. Slide the Support Cone, the Adjustment Cone, and the Grill together as shown. Hook the loop of the Grill to the tab of the Feeder Pan. Rotate the Feeder Pan over on the top of the Grill and Cones. Seat the Feeder Pan in the ring of the Grill. With the Feeder Pan fully seated rotate the pan clockwise to lock in place. Assemble the remaining Feeders.

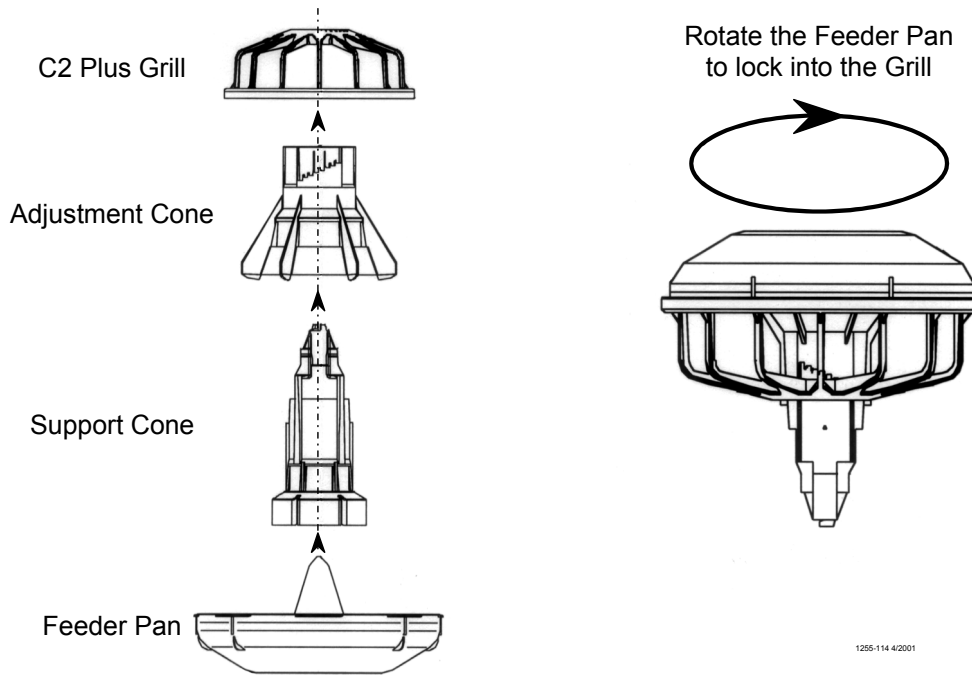

Figure 24. Assembling the Feeder Pan

Feeder Line Assembly and Suspension

Feeder Pan and Tube Assembly Process

1. Slide one Feeder Pan Assembly per hole onto the auger tubes.
IMPORTANT: Install all the feeders on the tubes in the same orientation.
 When sliding the feeders on the tubes, make sure the grill openings are on the same side of the tube.
1. Rotate the auger tubes so that the seam is down, this holds the Pan Assemblies in place on the tubes. See **Figure 25.**

1) With the Hem of the Feeder Tube up slide the Feeder Pan Assembly on the Feeder Tube.
 Position one (1) Feeder Pan Assembly over each hole on the Feeder Tube.

3) Rotate the Feeder Tube after the Feeder Pan Assemblies are in place. This will lock the Feeder Pan Assemblies in place

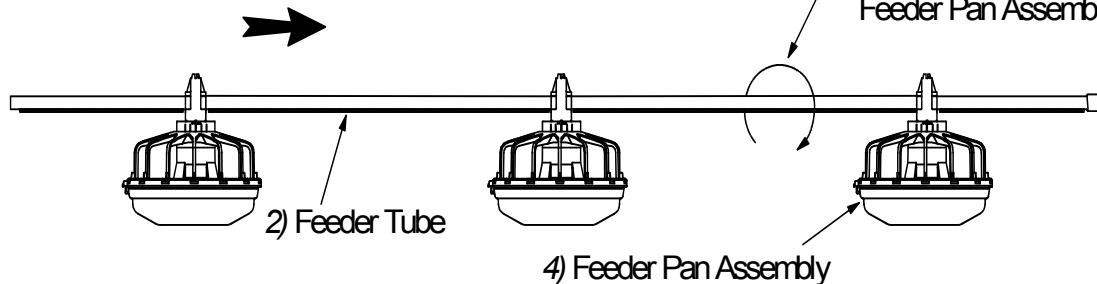

Figure 25. Assemble Feeders on tubes

Assemble and Suspend the Feeder Line

1. The auger tubes and feeders may be laid out end to end in approximately the final location of the line. **The belled end of each tube should be toward the Hopper end of the line.** See **Figure 26.**
2. Connect the individual feeder tubes together by inserting the straight end of one tube as far as possible into the belled end of the next tube. **The last Feeder Tube before the End Control Pan or Mid Line Control pan needs to be a Control Tube.**

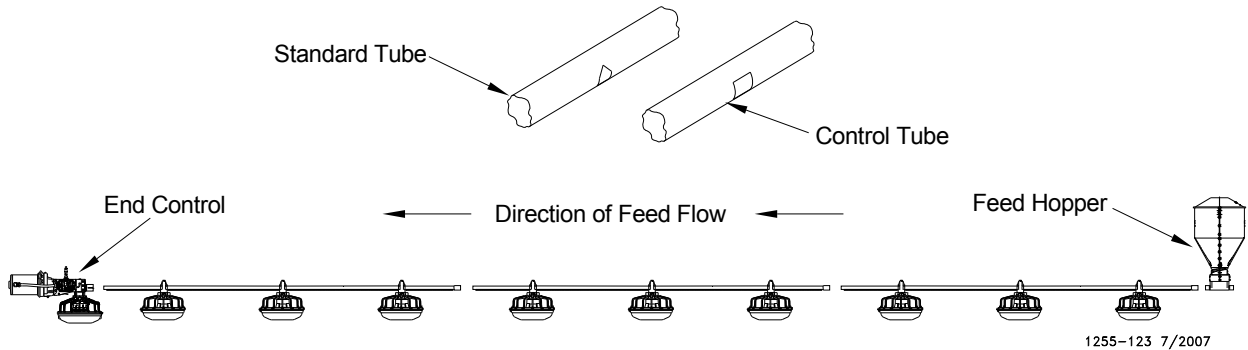

Figure 26. Hanger Installation

3. To achieve total feed drop out all along the system, the Chore-Time Logo should be centered at the crown of the tubes and all the Hangers should be installed as shown in **Figure 27.**

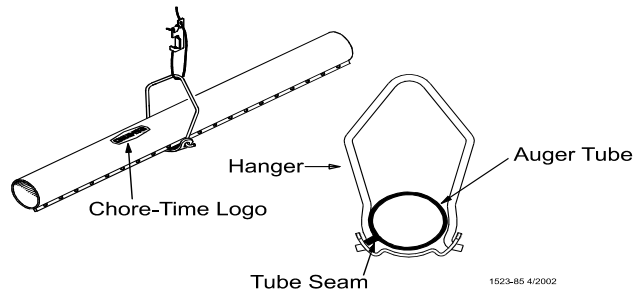

Figure 27. Hanger Installation

4. Place a Tube Clamp Assembly or Clamp/Anti-Roost Bracket at each joint. **Figure 28.** shows the standard Clamp and Clamp/Anti-Roost Bracket. Systems using 9' or 10' tubes require a Clamp/Anti-Roost Bracket at every **fifth** joint. Systems using 12' tubes require a Clamp/Anti-Roost Bracket at every **fourth** joint. All other joints in the system use the standard Tube Clamp Assembly.

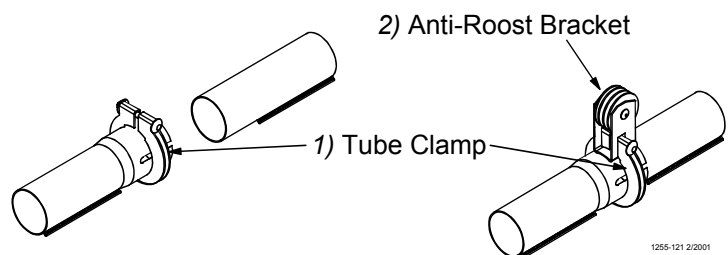

Figure 28. Tube Clamp and Tube Clamp with Anti-Roost Bracket

Continue down the entire length of the feeder line so that every joint is secured with a standard Clamp or Clamp/Anti-Roost Bracket. **Figure 29.** shows the proper clamp location on the tube joint. *Do not tighten the clamp at this time.*

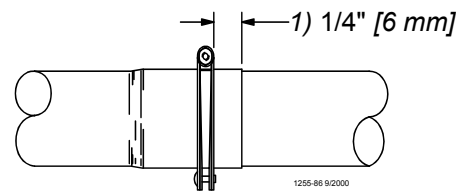

Figure 29. Clamp Installation

5. Install the Hangers on the feed line tube at the 8' [2.4 m] spacings determined by the suspension drop lines.

Figure 30. shows the proper installation of the Hanger Assembly. Make sure the outlet drop hole is downward when the Hangers are installed, otherwise feed will not be allowed to drop into the feeder pan.

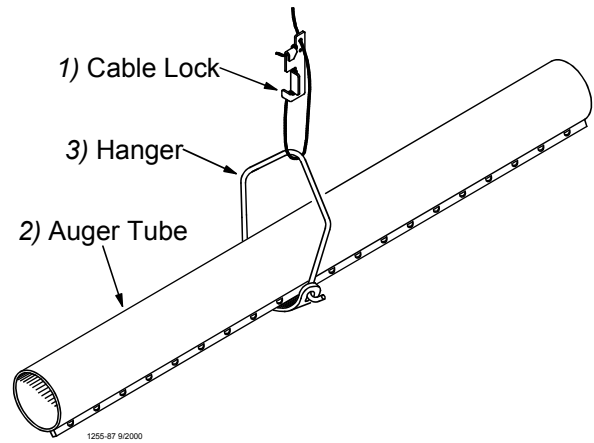

Figure 30. Hanger Installation

6. Install Adjustment Leveler within 6" [152 mm] of feeder line. **Figure 31.** shows the proper cable routing around the Adjustment Leveler.

7. Following the installation of all drops, check drop cables before raising feeder line. Cable must be tracking properly on all pulleys before raising the feeder line.

8. Raise the feeder line to a convenient working height.

9. With the feeder line suspended, measure from the floor or ceiling to the auger tubes to level the system.

10. Before tightening each clamp:

- make sure each tube is level (not sagging, sloping, etc.).
- make sure straight end of each tube is fully inserted in belled end of next tube.
- if providing total drop out, tubes should be rotated so that the Chore-Time Logo is on crown of tube.
- make sure the clamps are located, as shown in **Figure 29.**

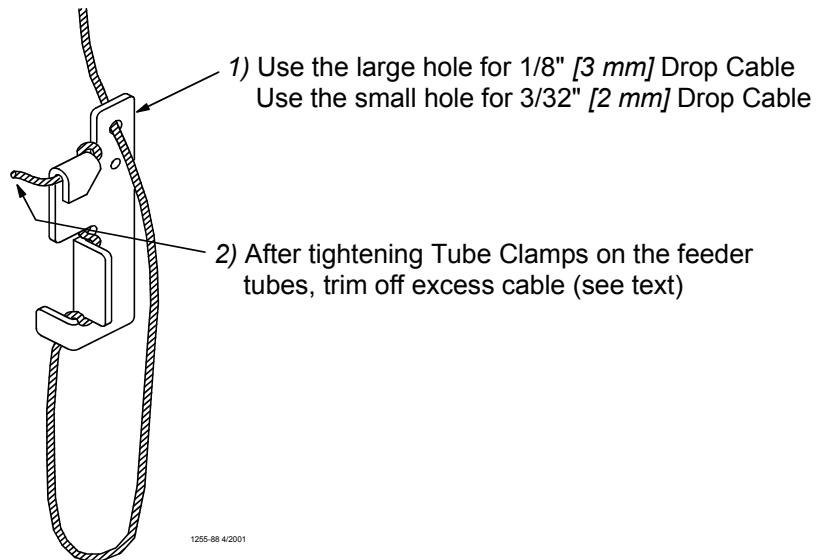

Figure 31. Cable Lock Threading

Finally, tighten the Tube Clamps on the feeder tubes. Clamp the joints securely, but do not crush the tubes. Re-adjust all Adjustment Levelers as needed and trim off excess cable as shown in **Figure 31.**

Installing the End Control, Boot Assembly, and Auger

The End Control Unit must be at least 10 feet [3 m] from the end of the building to allow birds access around the end of the feeder line.

1. Assemble the End Control Unit to the Feeder Line Control Tube using a clamp/anti-roost bracket. See **Figure 32. DO NOT INSTALL THE POWER UNIT AT THIS TIME.**

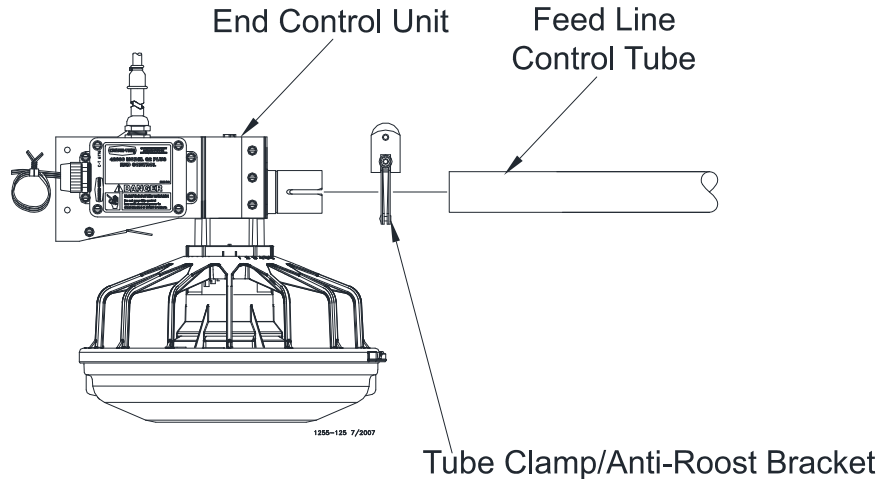

Figure 32. Connecting End Control Unit to the Feed Line Tube

2. Install the Feeder Boot by sliding the straight end of the Feeder Boot into the belled end of the Feeder Tube. Install a clamp/anti-roost bracket on the bell and tighten. The Feeder Boot must be level with the open top of the Feeder Boot flat. **Figure 33.**
3. **DO NOT INSTALL THE ANCHOR BEARING AND BEARING RETAINER AT THIS TIME.**

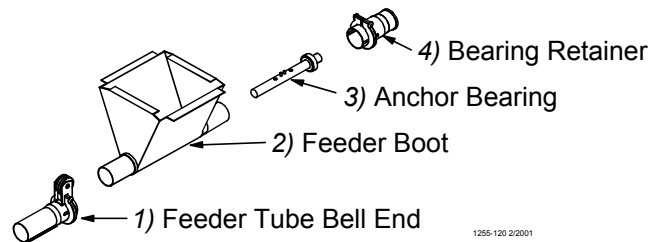
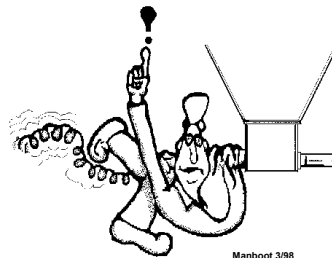

Figure 33. Installing the Feeder Boot

Auger Installation

Note: Use extreme caution when working with the auger. The auger is under tension and may spring causing personal injury. Wear protective clothing, gloves, and safety glasses when working with the auger.



**BE CAREFUL WHEN
WORKING WITH THE
AUGER!**

To avoid kinking the auger, be careful not to drop the rolled auger when handling. Inspect the auger carefully as it is installed. Small kinks may be straightened. Large kinks must be removed and the auger brazed back together. Cut the leading 18" [450 mm] and last 18" [450 mm] off each roll of auger. Also, cut out any other distorted auger sections and reconnect the auger as specified in the Auger Brazing section of this manual..

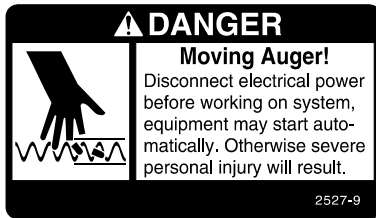

1. Use extreme caution when pushing the auger into the auger tubes. Keep your hand away from the end of the auger tube to avoid injury.
With the auger coiled about 6 feet [1.8 m] from the end of the boot, uncoil the auger from the outside and feed the auger through the boot into the tubes.
Push the auger into the tube in short strokes.
Uncoil and handle the auger carefully to avoid damaging or kinking the auger.
2. If more than one coil is required for each feeder line, the auger ends will have to be brazed together. Refer to the Brazing the Auger section in this manual.
3. Install the Anchor Bracket to the Power Unit/Gearhead, as shown in **Figure 34.**, with the included 5/16-18 Bolts.

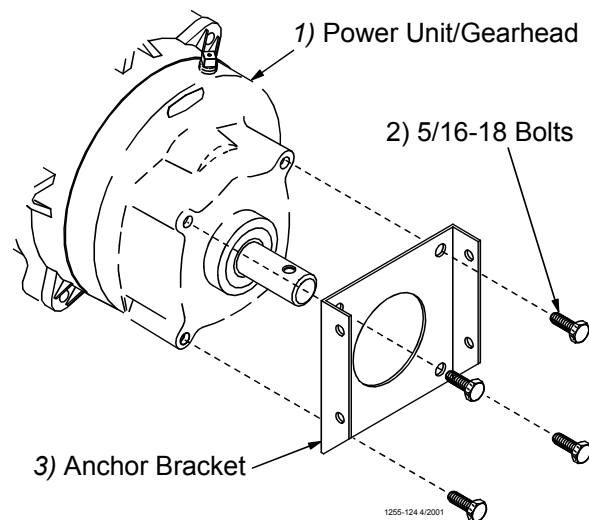

Figure 34. Assemble the Anchor Bracket to the Power Unit/Gearhead

4. Slide the Drive Tube and flat washer over the output shaft on the Power Unit, as shown in **Figure 35.**
5. Continue installing auger until the auger reaches the Control Unit end of the feeder line.
6. Turn the Drive Tube Weldment into the auger, then attach to the output shaft of the Power Unit, as shown in

Figure 35. Use the Driver Block to secure the auger to the Output Shaft.

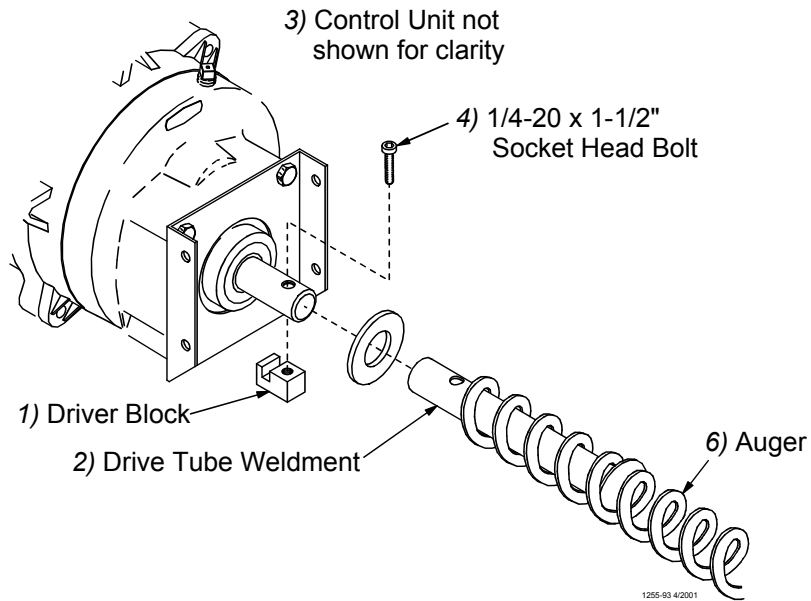

Figure 35. Auger Driver Components

7. Attach the Anchor Plate and Gearhead Assembly to the Control Unit Body using the included 1/4" Lock Washers and 1/4-20 x 1/2" Bolts. See **Figure 36.**

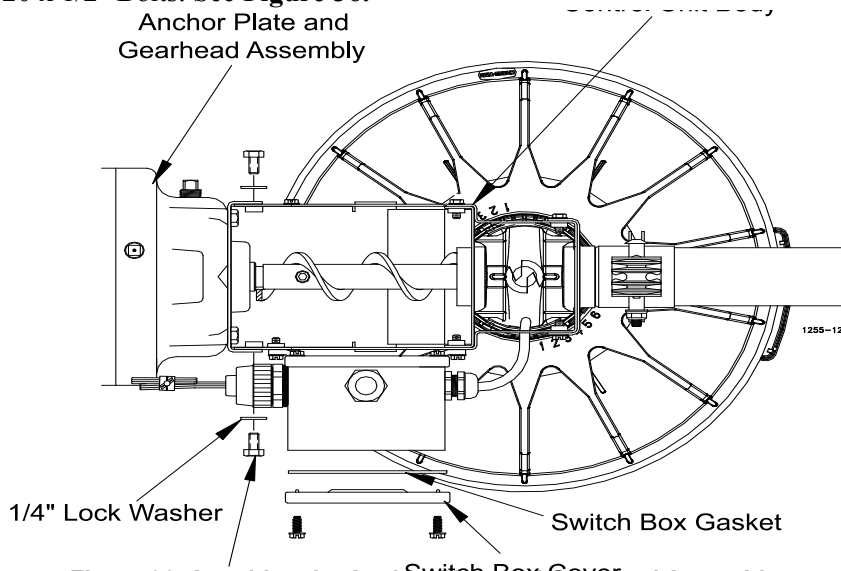

Figure 36. Attaching the Anchor Plate and Gearhead Assembly to the Control Unit Body

8. Install the Metal Water Tight Connector (**Item 1**) in the Feed Line Motor (**Item 2**). Cut the Flex Conduit (**Item 3**) to length. Slide the wires from the end control through the Flex Conduit (**Item 3**). Install the Flex

Conduit (Item 3) in the connectors. Connect the wires to the Feed Line Motor (Item 2).

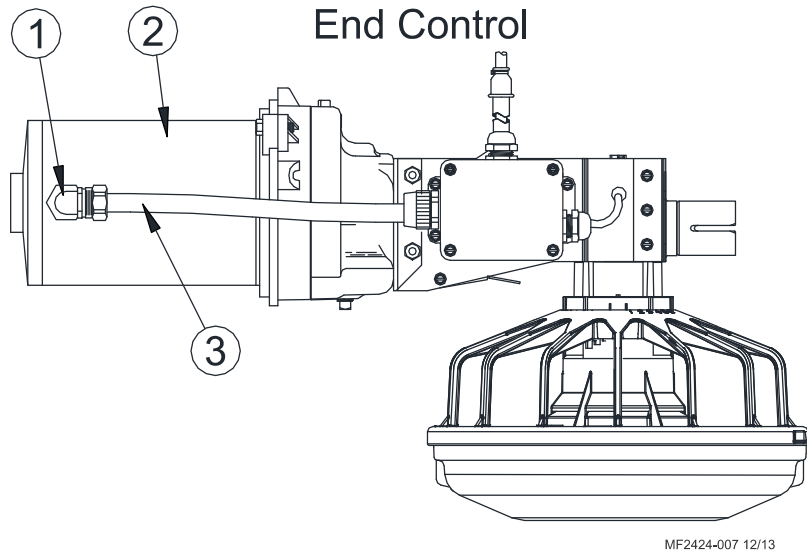

Figure 37. Installing Water Tight, Cutting and Installing Conduit

9. Attach all covers and wire according to the wiring section of this manual.
10. Pull the auger at the boot end until it begins stretching. Then let it relax. In the *relaxed* position, mark the auger at the end of the boot. See **Figure 38**.

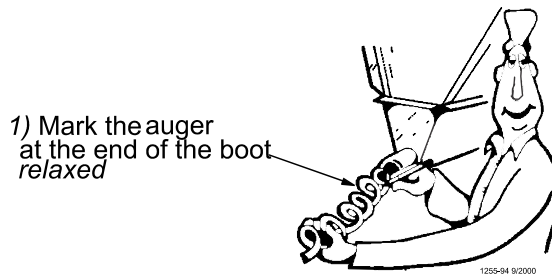

Figure 38. Measure the Auger from the relaxed position

11. Auger stretch:

The auger needs to be stretched 7" [180 mm] per 100' [30 m]. Example: A 300' [90 m] feeder line requires 21" [500 mm] of stretch.

Beginning at the *relaxed* position, measure the required amount of stretch. Mark the auger at that point. Grip the auger 8" [200 mm] ahead of this mark with locking pliers. Allow the auger to pull back into the boot so that the pliers rest against the end of the boot. See **Figure 44**.

Auger Installation

Note: Use extreme caution when working with the auger. The auger is under tension and may spring causing personal injury. Wear protective clothing, gloves, and safety glasses when working with the auger.

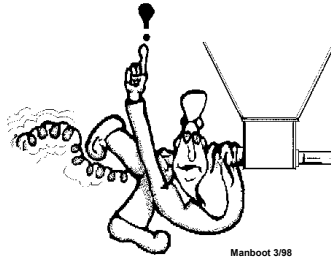

**BE CAREFUL WHEN
WORKING WITH THE
AUGER!**

To avoid kinking the auger, be careful not to drop the rolled auger when handling. Inspect the auger carefully as it is installed. Small kinks may be straightened. Large kinks must be removed and the auger brazed back together.

Cut the leading 18" [450 mm] and last 18" [450 mm] off each roll of auger. Also, cut out any other distorted auger sections and reconnect the auger as specified in the Auger Brazing section of this manual.

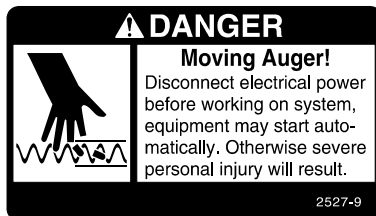

1. Use extreme caution when pushing the auger into the auger tubes. Keep your hand away from the end of the auger tube to avoid injury.
With the auger coiled about 6 feet [1.8 m] from the end of the boot, uncoil the auger from the outside and feed the auger through the boot into the tubes.
Push the auger into the tube in short strokes.
Uncoil and handle the auger carefully to avoid damaging or kinking the auger.
2. If more than one coil is required for each feeder line, the auger ends will have to be brazed together. Refer to the Brazing the Auger section in this manual.
3. Install the Anchor Bracket to the Power Unit/Gearhead, as shown in **Figure 39**, with the included 5/16-18 Bolts.

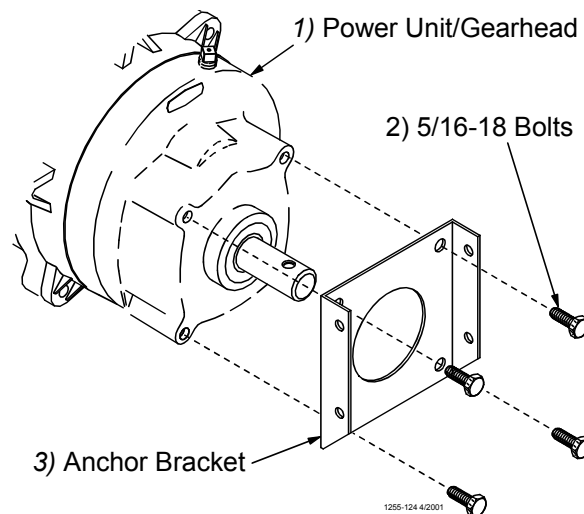

Figure 39. Assemble the Anchor Bracket to the Power Unit/Gearhead

4. Slide the Drive Tube and flat washer over the output shaft on the Power Unit, as shown in **Figure 40**.
5. Continue installing auger until the auger reaches the Control Unit end of the feeder line.
6. Turn the Drive Tube Weldment into the auger, then attach to the output shaft of the Power Unit, as shown in **Figure 40**. Use the Driver Block to secure the auger to the Output Shaft.

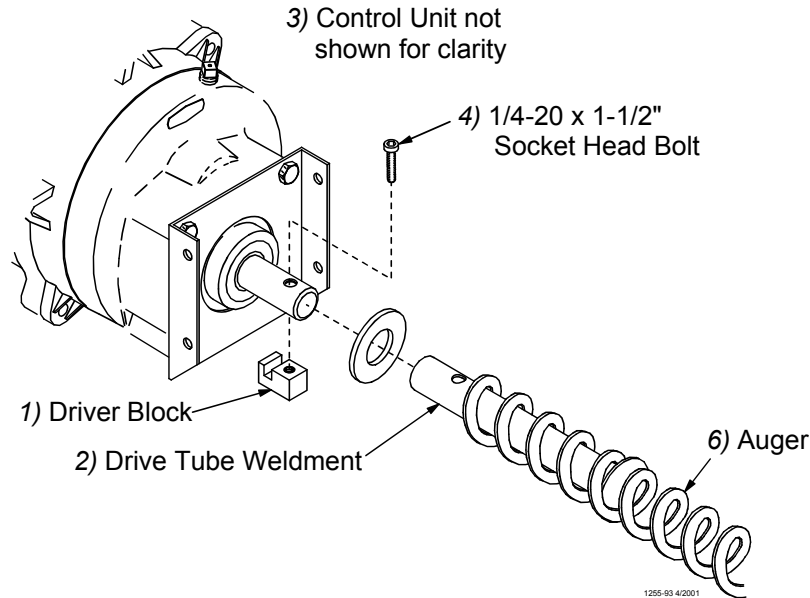

Figure 40. Auger Driver Components

7. Attach the Anchor Plate and Gearhead Assembly to the Control Unit Body using the included 1/4" Lock Washers and 1/4-20 x 1/2" Bolts. See **Figure 41**.

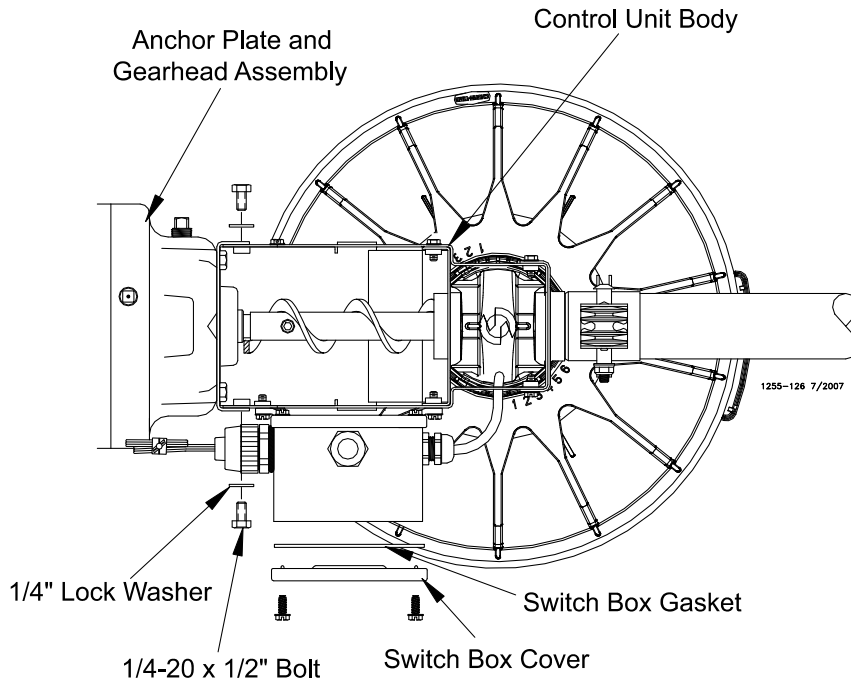

Figure 41. Attaching the Anchor Plate and Gearhead Assembly to the Control Unit Body

8. Install the Metal Water Tight Connector (**item 1**) in the Feed Line Motor (**item 2**). Cut the Flex Conduit (**item 3**) to length. Slide the wires from the end control through the Flex Conduit (**item 3**). Install the Flex Conduit (**item 3**) in the connectors. Connect the wires to the Feed Line Motor (**item 2**), see **figure 42**.

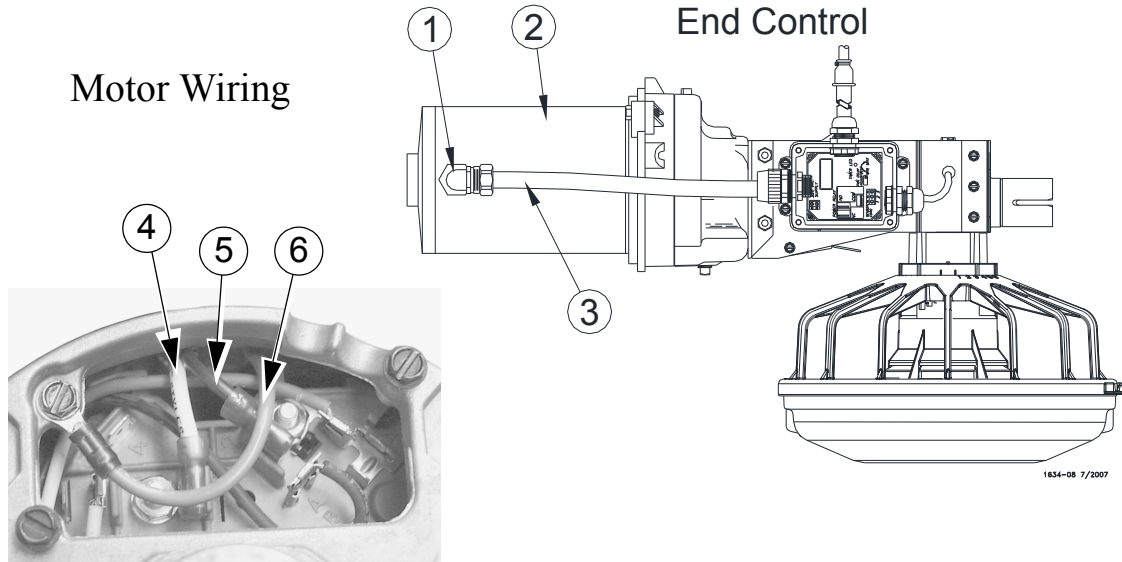

Figure 42. Wiring the Motor

9. Attach all covers and wire according to the wiring section of this manual.

10. Pull the auger at the boot end until it begins stretching. Then let it relax. In the *relaxed* position, mark the auger at the end of the boot. See **Figure 43**.

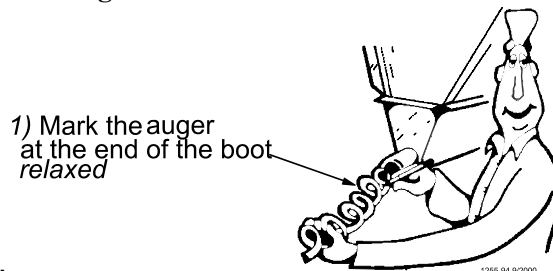

Figure 43. Measure the Auger from the relaxed position

11. Auger stretch:

The auger needs to be stretched 7" [180 mm] per 100' [30 m]. Example: A 300' [90 m] feeder line requires 21" [500 mm] of stretch.

Beginning at the *relaxed* position, measure the required amount of stretch. Mark the auger at that point.

Grip the auger 8" [200 mm] ahead of this mark with locking pliers. Allow the auger to pull back into the boot so that the pliers rest against the end of the boot. See **Figure 44**.

Use a hacksaw or bolt cutters to cut the auger at the stretched auger mark.

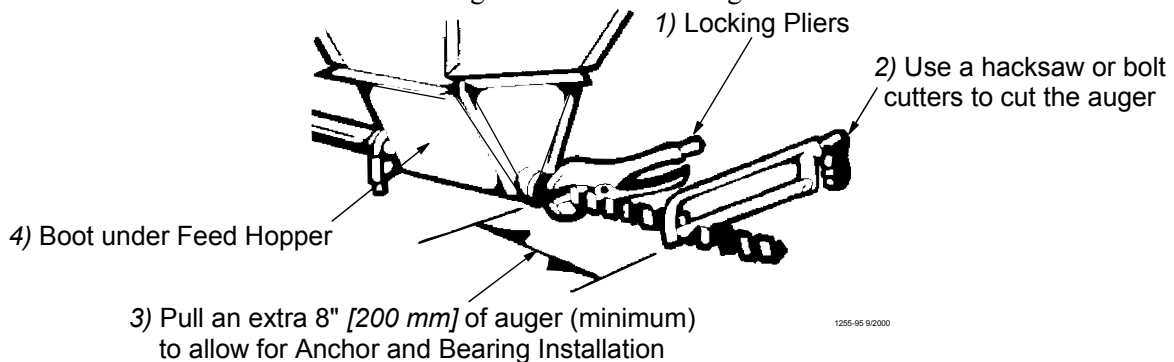

Figure 44. Cut the Auger with required stretch

12. Insert the Anchor Assembly into the auger until it touches the washer at the back of the anchor. Tighten the setscrews in the center of the anchor until they touch the auger, then tighten a maximum of 1/2 turn. See Figure 45.

DO NOT OVERTIGHTEN THE SET SCREWS.

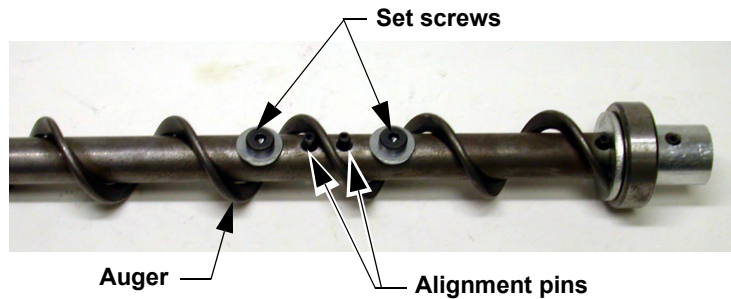

Figure 45. Auger and Anchor Bearing Connection

13. **Carefully** remove the locking pliers while holding onto the Anchor and Bearing Assembly and auger securely.

Slowly ease the auger back into the tube. Use caution. If the auger is allowed to spring back, the bearing race may crack.

Install the Bearing Retainer and fasten with a tube clamp. Keep the Bearing Retainer flush with the end of the anchor for safety.

14. Place the cannonball in the boot.

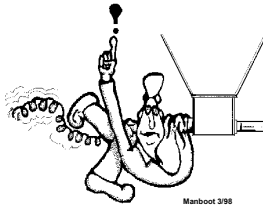

BE CAREFUL WHEN WORKING WITH THE AUGER!

Auger Brazing

The auger should be brazed if it is necessary to splice or lengthen it. A bronze, flux coated rod is recommended. The ends of the auger should butt against each other, **DO NOT THREAD INSIDE EACH OTHER.** See Figure 46. The joint should be well filled with no sharp edges or rough corners to wear against the tube. To align the auger for brazing, lay it in angle iron or channel iron and clamp it firmly in place. Use low heat. Allow the joint to air cool; rapid cooling will cause the auger to become brittle.

2) Lap the auger ends approximately 1" [25 mm]

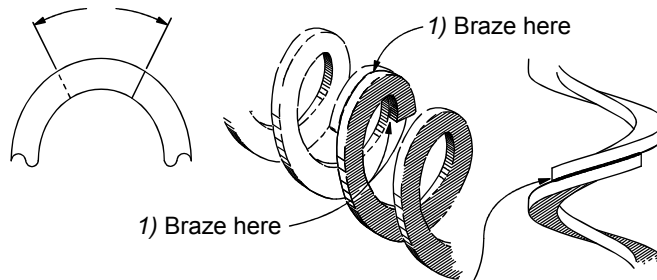

3) Butt the auger ends together
DO NOT thread the auger together

Figure 46. Auger Brazing

Mid-Line Control

Mid-Line Control Units are available for the MODEL C2 PLUS & G PLUS Feeders. The Mid-Line Controls are shown in **Figure 47**.

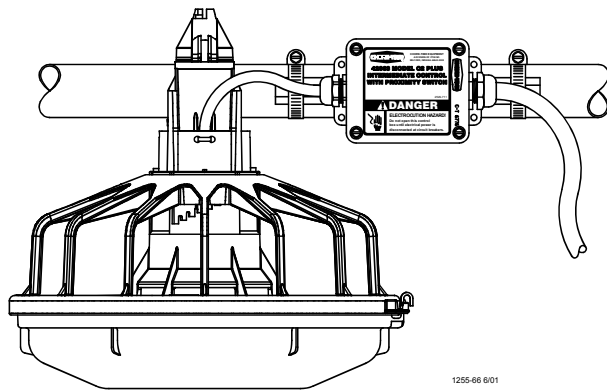

MODEL C2 PLUS Mid-Line Control with (ES) Proximity Switch

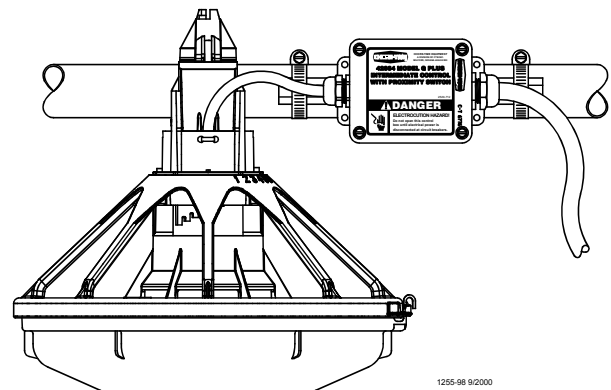

MODEL G PLUS Mid-Line Control with (ES) Proximity Switch

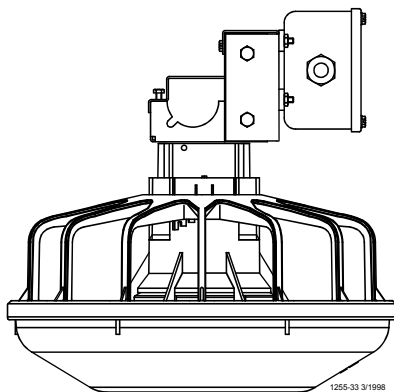

MODEL C2 PLUS Mid-Line Control with Mechanical Switch and Windows

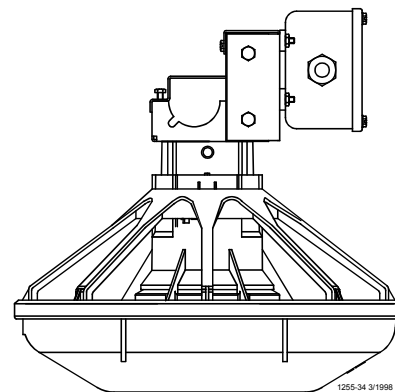

MODEL G PLUS Mid-Line Control with Mechanical Switch and Windows

Figure 47. Mid-Line Controls

The Mid-Line Control makes it possible to operate the feeding system when birds are confined away from the End Control Unit. Chore-Time recommends placing the Mid-Line Control Feeder at least 2 pans away from the curtain or partition. See **Figure 48**.

1. **New Feeder Lines:** Leave one feeder pan assembly off the feeder control tube at the point where the Mid-Line Control needs to be placed. The feeder line can be assembled and suspended before attaching the Mid-Line Control; or the Mid-Line Control may be attached to the feeder tube when the other pans are installed.
Existing Feeder Lines: Cut the Grill Support and remove the feeder pan at the location where the

Mid-Line Control will be installed.

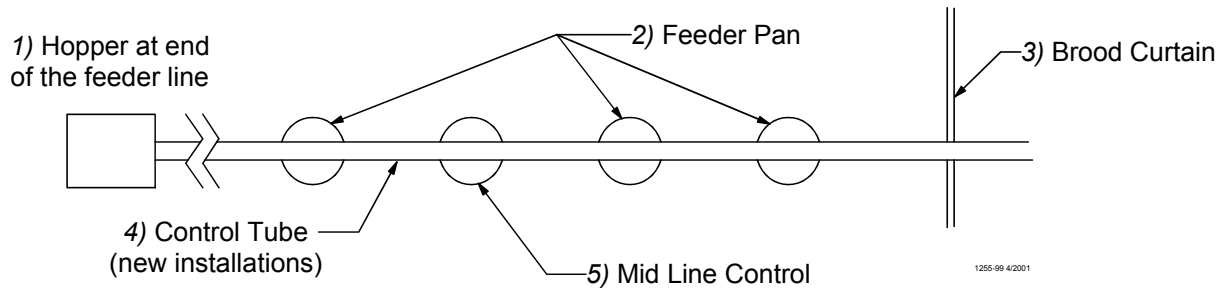
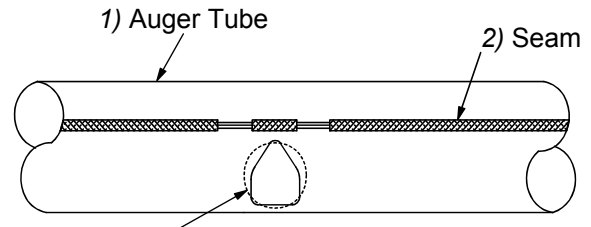

Figure 48. Mid-Line Control Location Diagram

2. **New Feeder Lines:** Go to step 3.

Existing Feeder Lines: Enlarge the outlet hole to approximately 1" [2.5 cm] diameter for the Mid-Line Control, plus enlarge (2) outlet holes in front (to the hopper end) of the Mid-Line Control. Use unibit to enlarge hole size. Be sure there are no burrs inside the tube to catch the auger.



- 3) Use a Unibit to enlarge outlet holes on existing feeder lines

Figure 49. Enlarging Outlet Holes

3. Install the Mid-Line Control:

Mechanical Switch:

- Remove the two hex head screws on the control top.
- Lift off the control top.
- Cradle the feeder tube in the control housing. The feeder tube may have to be turned slightly to allow the pan to hang straight.
- Clamp the control in place by inserting tabs on the control top into the slots on the control body. Install and tighten the two hex head screws previously removed.

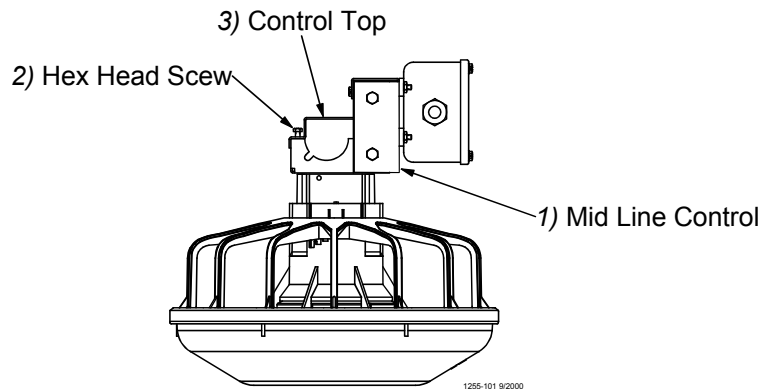

Figure 50. Mid-Line Control Installation

Electronic Sensor:

- Assemble the Mid-Line Control to the Feeder Tube as shown in **Figure 51**.
 - Attach the Switch Box Assembly to the Feeder Tube with Hose Clamps as shown in **Figure 51**.
4. Install a toggle switch, out of reach of the birds, to disconnect power to the Mid-Line Control. This allows the Mid-Line Control to serve as standard feeder when not used as a control feeder.
5. Wire the Mid-Line Control as shown in the wiring diagram section of this manual.

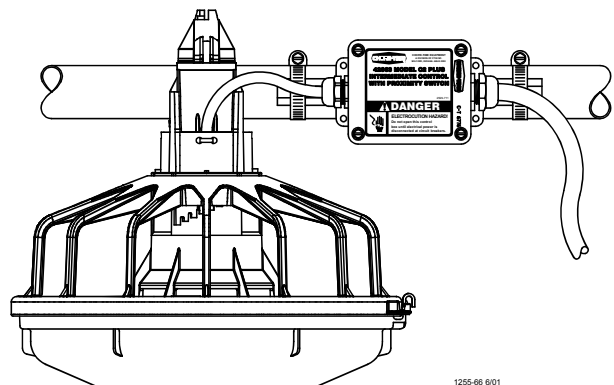
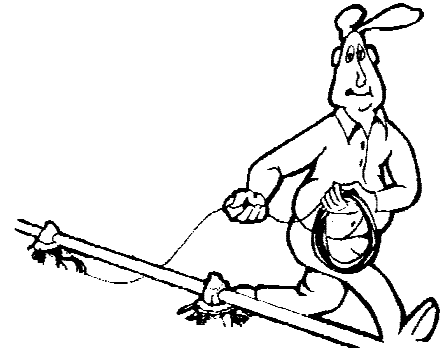

Figure 51. Installing the (ES) Mid Line Control

Anti-Roost Assembly

6. Unroll the bulk anti-roost cable. Note: If the cable is unrolled as shown in **Figure 52.**, taking 5 loops of the coil with one hand, then changing hands to remove 5 loops as it is unrolled, it will lie flat during installation.



Shock2 3/98
Figure 52. Unrolling Cable

7. Start at the hopper end of the line and form a loop around the anti-roost bracket. For best results, make a double loop around the anti-roost insulator in the center groove of the insulator and fasten with a 1/16" cable clamp as shown in **Figure 53.**
8. Insert the cable in the insulator on the top of each Grill Support between the hopper and the next anti-roost bracket.

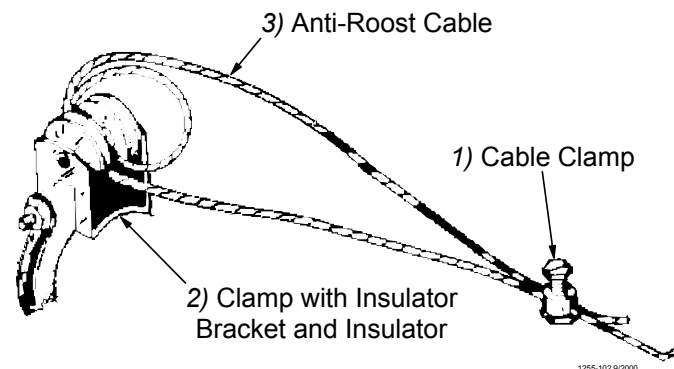

1255-102 9/2000
Figure 53. Anti-Roost Cable at the Hopper

9. Attach a spring in the center groove at the second anti-roost bracket and cut the cable at this point. See **Figure 54.**
10. Thread the ends of the cable through the end of the spring. Pull the cable tight so that there is 3/4" to 1" [20 to 25 mm] of stretch in the spring. Clamp the cable to form a loop and cut off any excess. See **Figure 54.**
11. Attach the cable to the insulator. For best results, make a double loop around the anti-roost insulator in the center groove of the insulator and fasten with a 1/16" cable clamp as shown in **Figure 54.**

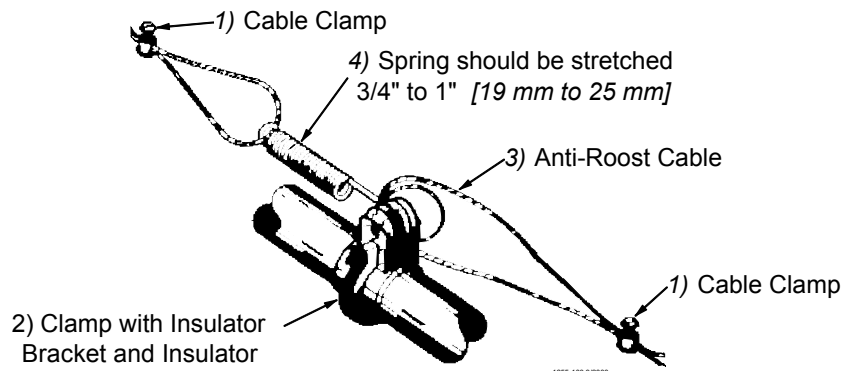

1255-103 9/2000
Figure 54. Anti-Roost Cable Mid-Line Connection

12. Run the cable to the next insulator, attach a spring in the center groove at the anti-roost bracket and cut the cable at this point. The cable should be positioned in the insulator built into the top of each grill support along the feeder line.
13. Repeat this installation until the anti-roost cable is installed along the entire feeder line.
14. At the control unit, after clamping the cable to the spring, cut the cable about 8" to 10" [200 to 250 mm] longer than necessary. Feed the end of the cable through the center of the spring, around the first insulator on the control unit, and clamp the cable using the cable clamp supplied with the control unit. See **Figure 55.** Install the wire form on the control unit insulators. Be sure the guard snaps into the retainers molded into the

insulators. See **Figure 55**.

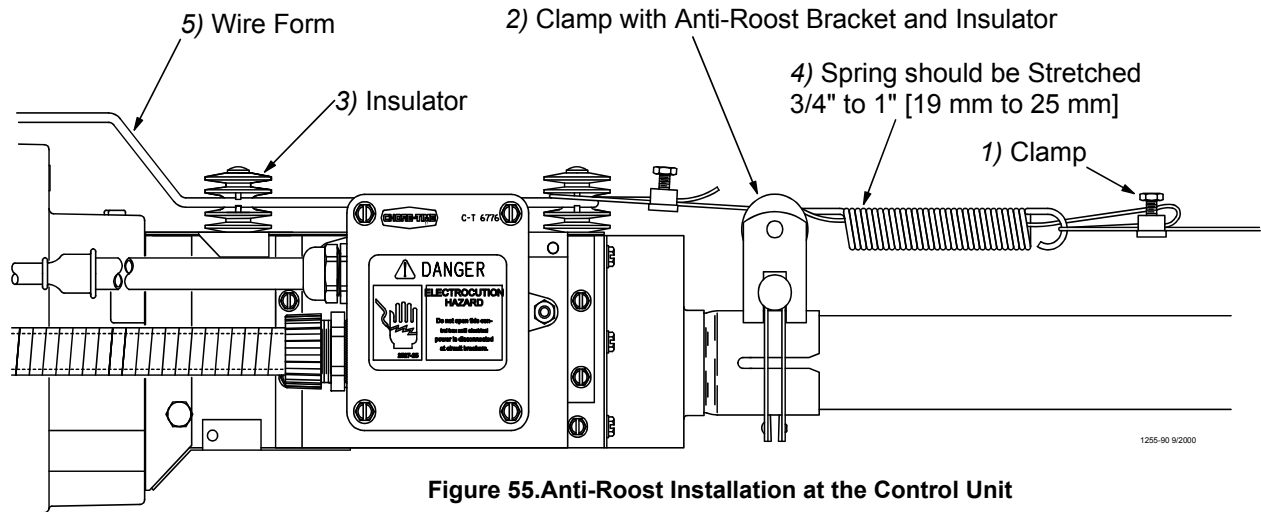

Figure 55. Anti-Roost Installation at the Control Unit

15. Install the Poultry Trainer or Line Charger, as shown in **Figure 56**. or **Figure 57**.

The Poultry Trainer is used to power all Anti-Roost lines in a house. See **Figure 56**.

The Line Charger is used to power individual Anti-Roost lines in a house. See **Figure 57**. Route the charger wire from the Poultry Trainer or Line Charger to the Anti-Roost system. Secure the Charger Wire to the Anti-Roost cable, using a cable clamp.

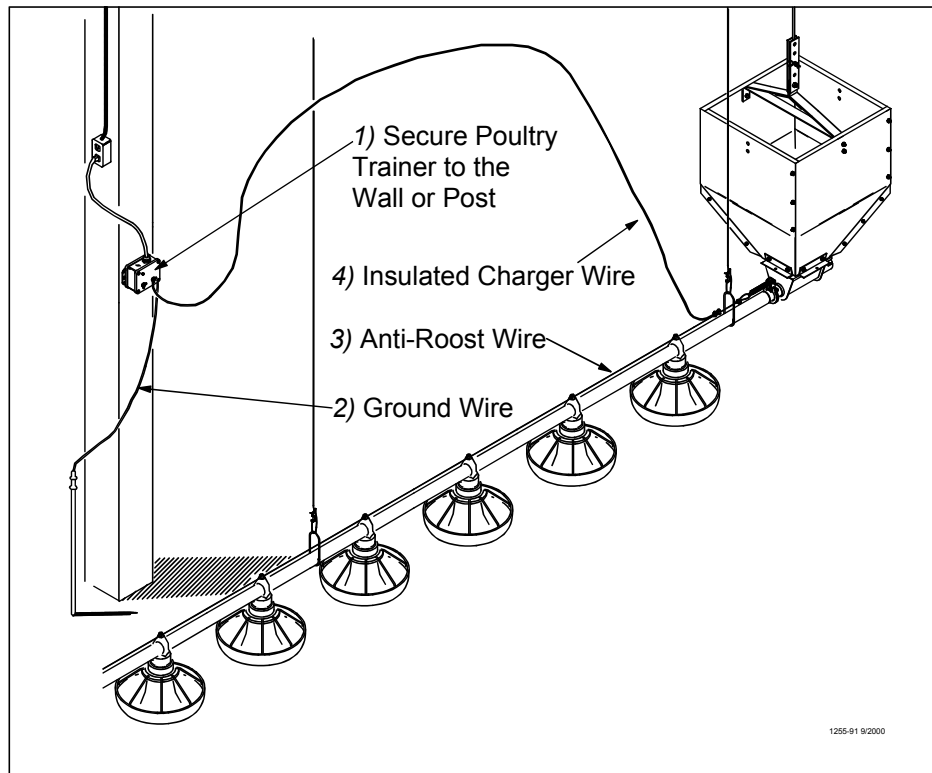

Figure 56. Poultry Trainer Installation

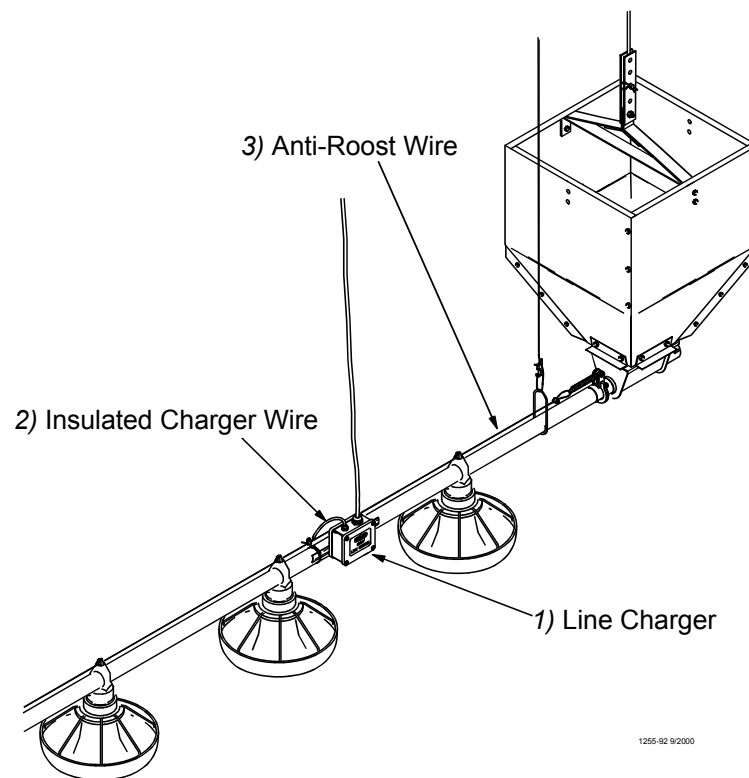
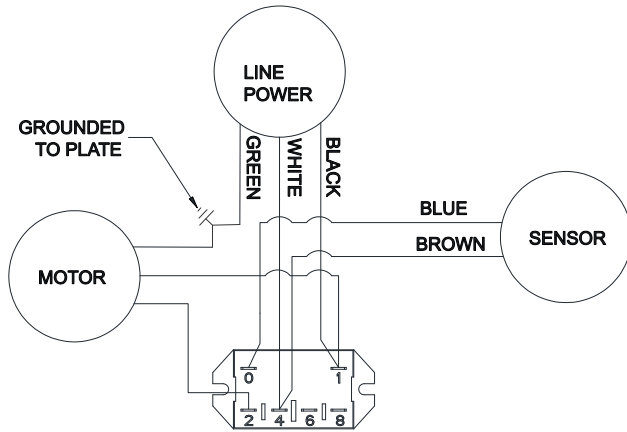

Figure 57. Line Charger Installation

16. The **anti-roost system** *must* be on a **separate electrical circuit**, allowing the system to be **disconnected by a switch near the door**.
Remember, the anti-roost system should be **grounded through the poultry trainer**.

Wiring

End Control with Electronic Sensor (ES) Internal Wiring



2424-001 10/13

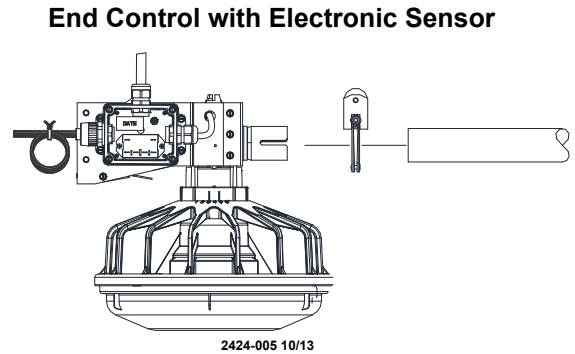

Electronic Sensor Control Wiring Diagram

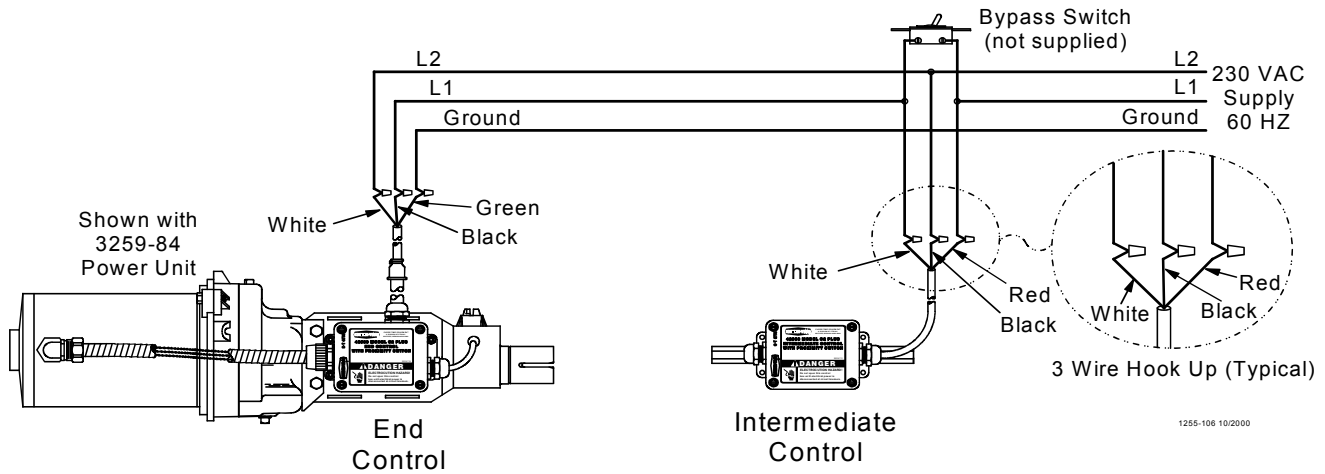

1255-106 10/2000

Mid Control with Electronic Sensor (ES) Internal Wiring

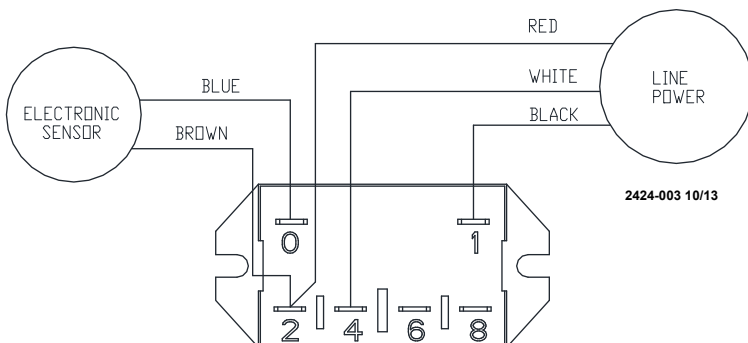

2424-003 10/13

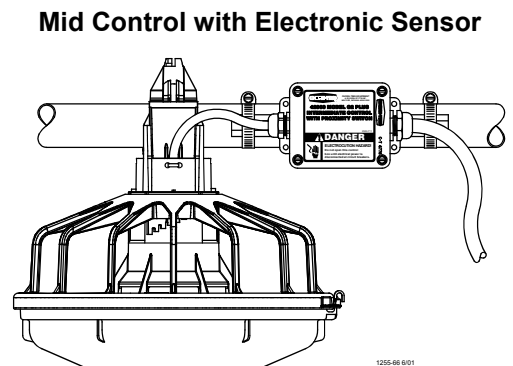

Mechanical Switch Single Phase(Ø) Wiring Diagram

FROM DISCONNECT OR
CONTROL DISCONNECT
220/230 VOLTS 50/60 HZ

SINGLE PHASE WIRING DIAGRAM

FEEDER LINE MOTOR
220/230 VOLTS 50/60 HZ
SINGLE PHASE

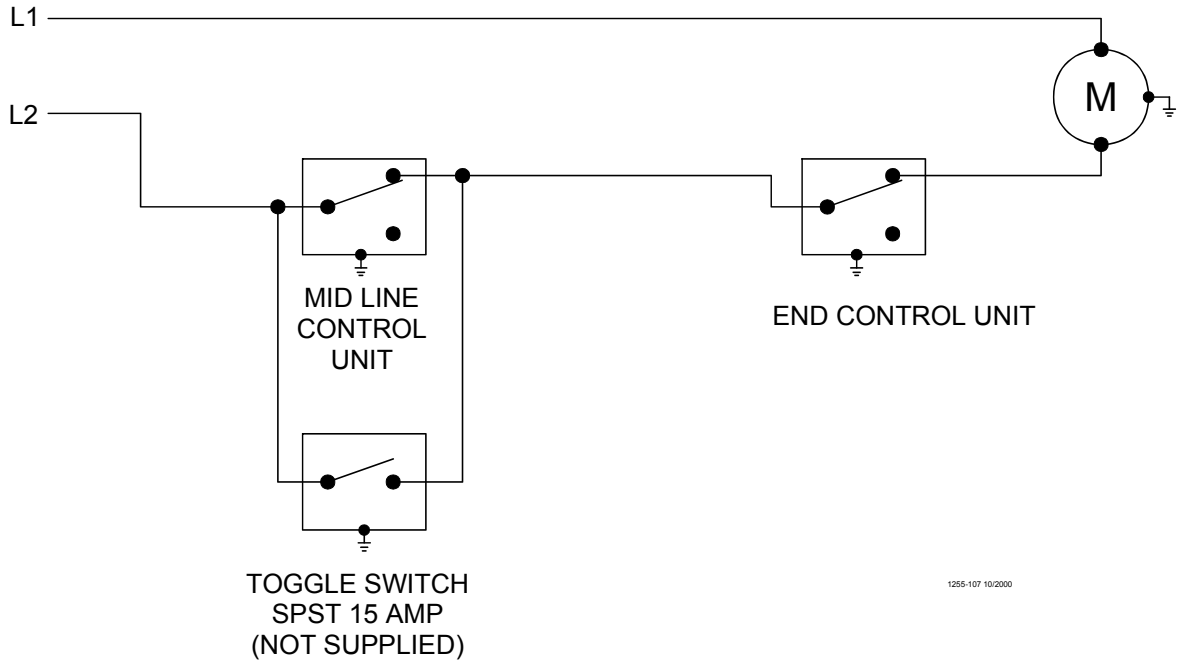

Mechanical Switch Single Phase(Ø) Wiring Diagram with Motor Starter

SINGLE PHASE

FROM DISCONNECT OR
CONTROL DISCONNECT
220/230 VOLTS 50/60 HZ

TO ADDITIONAL
FEEDER LINES

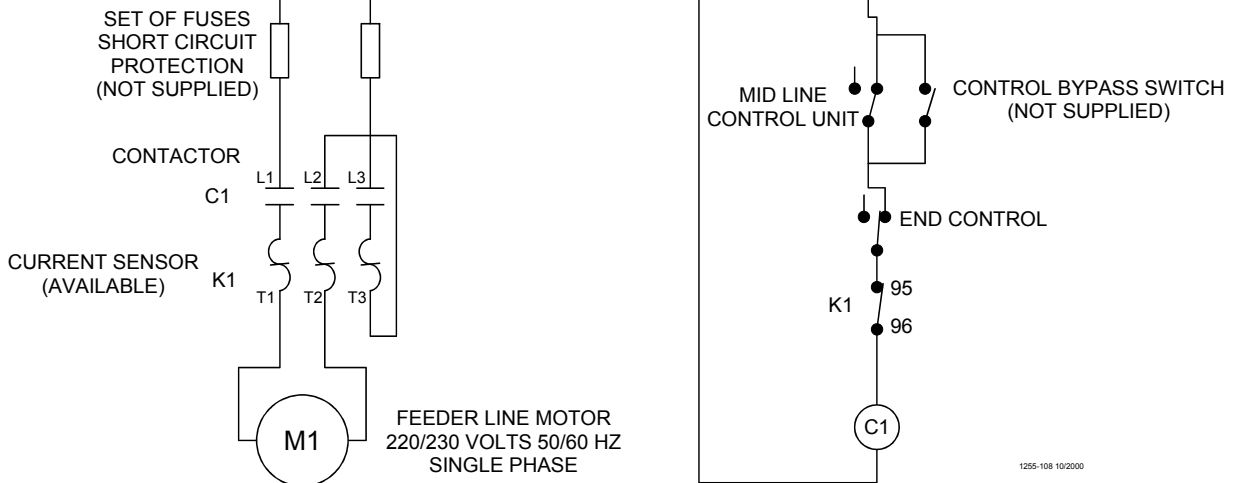

Mechanical Switch Three Phase(Ø) Wiring Diagram: 220 V.

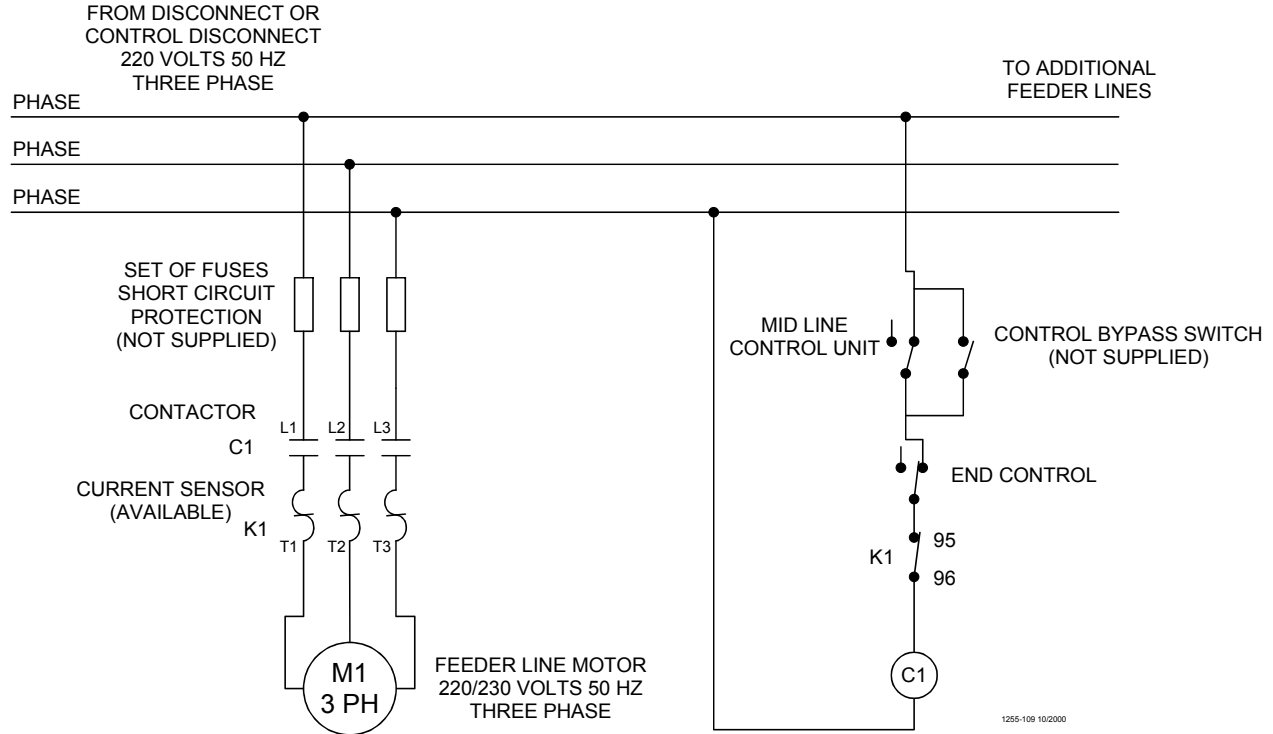

Mechanical Switch Three Phase(Ø) Wiring Diagram: 380/415 V.

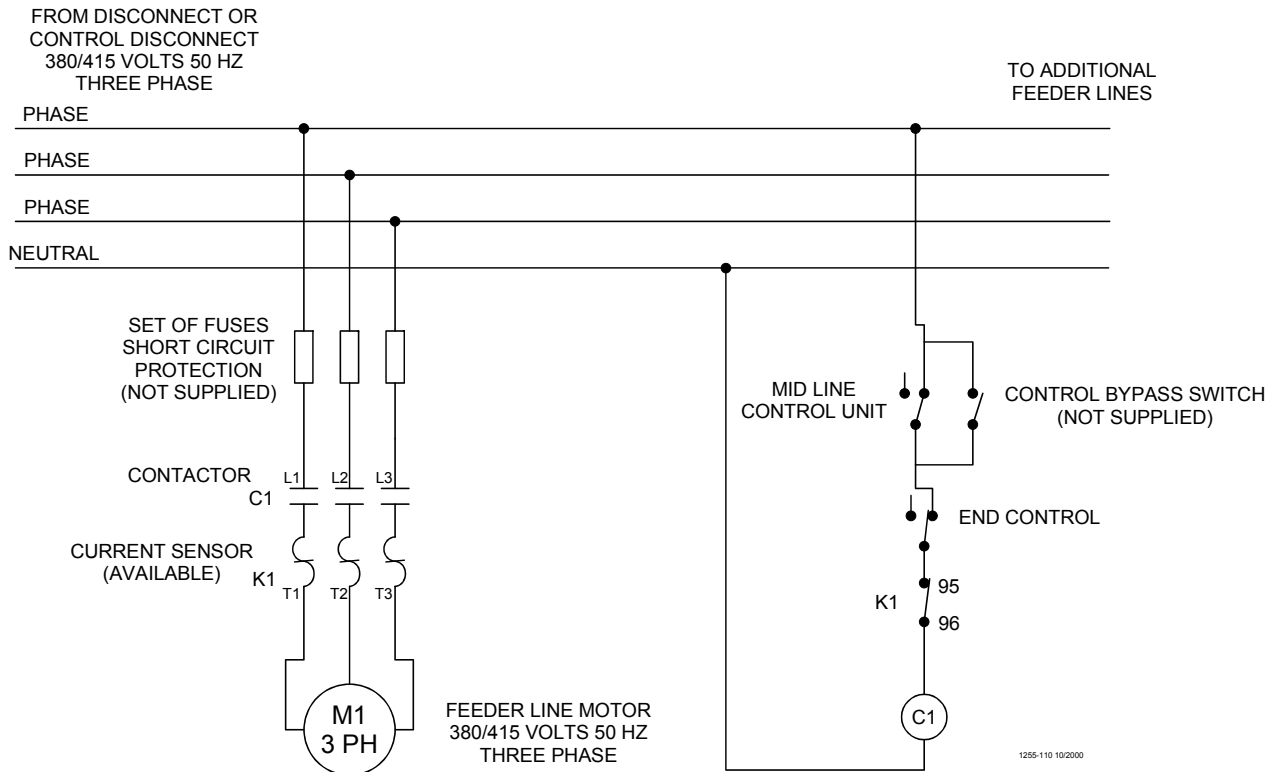

Electronic Sensor Three Phase (Ø) Wiring

FROM DISCONNECT OR
CONTROL DISCONNECT
220/380 VOLTS 50 HZ.
THREE PHASE

TO ADDITIONAL
FEEDER LINES

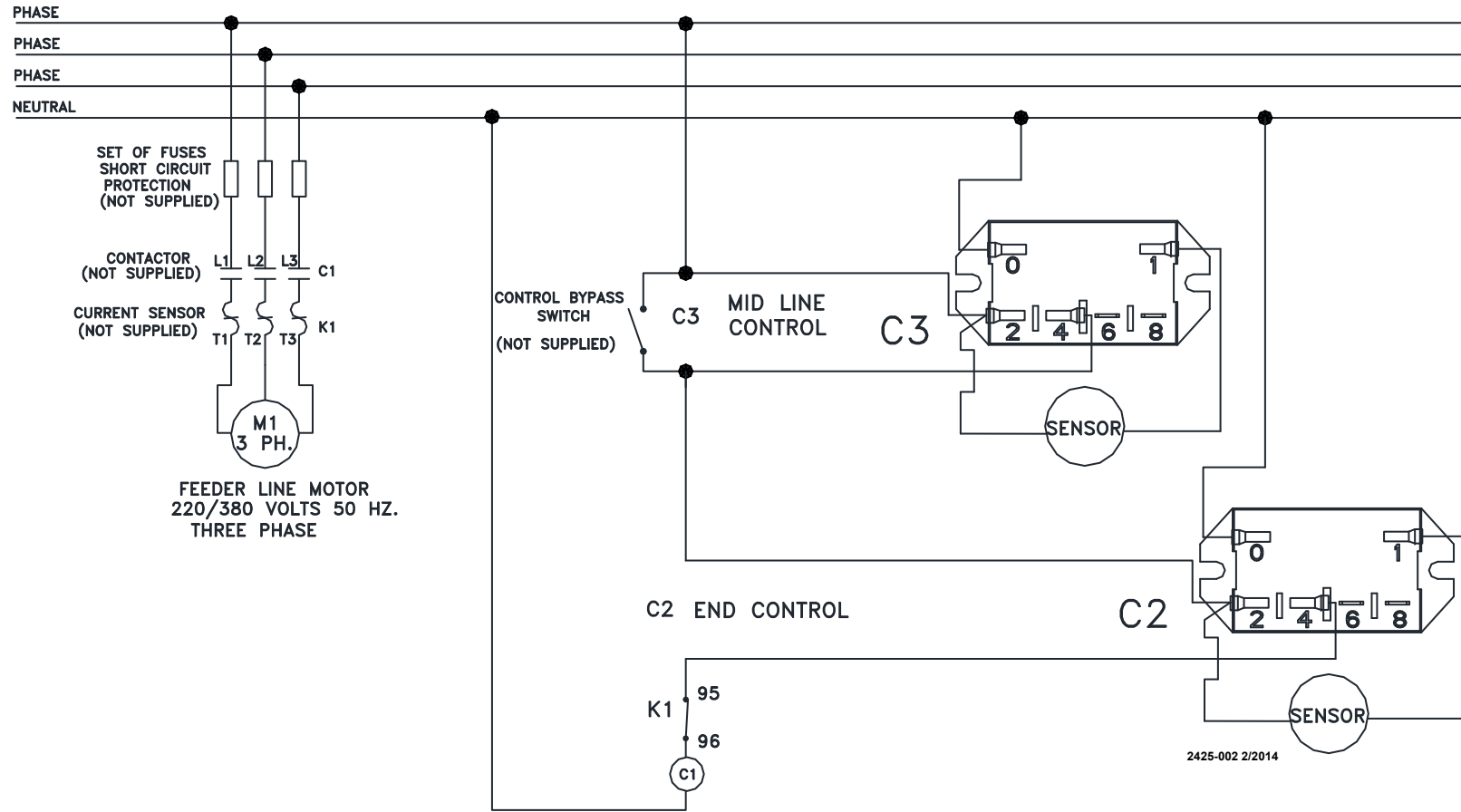

2425-002 2/2014

Troubleshooting

ALWAYS DISCONNECT POWER TO THE SYSTEM WHEN SERVICING OR MAINTAINING THE EQUIPMENT. FAILURE TO DISCONNECT POWER MAY CAUSE INJURY OR DEATH.

Service and maintenance work should be done by a qualified technician only.

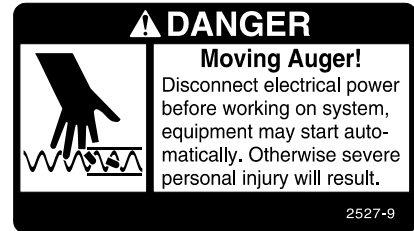

Problem	Possible Cause	Corrective Action
None of the feeder lines will operate	No power supplied to equipment	Replace burned fuses or reset circuit breaker Make sure voltage required is supplied
	Time Clock or relay defective	Replace Time Clock or relay
	Time Clock improperly programmed	Refer to Programming the Time Clock section and reprogram the Time Clock
Feeder line will not operate	Power unit cord not plugged in sufficiently to make contact	Check motor cord plug at control unit and control unit plug at outlet for connection
	Motor cord wires are broken at plug or where cord enters motor	Check cord for continuity Replace if defective
	Power Units thermal overload tripped	Push motor overload reset button to reset
	Control unit switch defective or out of adjustment	Adjust switch according to the Switch Adjustment Procedure in the maintenance section
Motor overloads frequently	Oil on new auger loads motor excessively when feed is carried for first time	Polish auger by running 50 lb (20 kg) increments of feed out to pans
	Inadequate power reaching motors	Check line voltage at the motors Check starting current draw at motors Wiring of adequate size is essential to feeder operation
	Object caught in the auger; motor runs, stalls, then auger spins in reverse	Check hopper boot, control unit and pan outlet holes for foreign objects Remove obstruction
Auger runs erratically	Frozen or cracked bearing at boot anchor	Replace bearing Slowly ease auger back into tube Be careful not to damage the bearing when reinserting the auger
	Insufficient stretch in auger	Shorten the auger
	Obstruction in the auger	Remove obstruction
Auger tube or boot wears out rapidly (Noisy feeder operation)	Auger is bent or kinked	Repair or replace damaged auger
	End of auger is riding up on anchor weldment	Auger must not be positioned over weld on anchor Check for bent or damaged auger
Oil leaking out of seals on power unit	Gearhead vent plug not installed	Replace plastic shipping plug with vent plug
	Defective gear head seal	Replace seal
Not enough feed supplied to the feeder pans	Insufficient time programmed on the time clock	Add more operating time to feeding period
	Feeder line control unit switch out of adjustment	Adjust switch according to the Switch Adjustment Procedure in the maintenance section

Maintenance

Floor Feeding System Maintenance

The MODEL C2 PLUS and MODEL G PLUS Feeders require minimum maintenance. However, a routine periodic inspection of the equipment will prevent unnecessary problems.

Maintenance should be done by a qualified technician.

ALWAYS DISCONNECT POWER TO THE SYSTEM WHEN SERVICING OR MAINTAINING THE EQUIPMENT. FAILURE TO DISCONNECT POWER MAY CAUSE INJURY OR DEATH.

Gear Head Maintenance

Refer to “Gearhead Maintenance” on page 37.

Check the oil level in the gear heads at installation and every 6 months. The Pipe Plug, on the side of the gear head, indicates proper oil level. Add SAE 40W oil when necessary.

The oil in the gearheads should be replaced every 12 months with new SAE 40W oil

- A. Remove the bottom Pipe Plug to drain the oil. Discard used oil in accordance with local and national codes.
- B. Wipe any debris off the magnet on the bottom Pipe Plug and reinstall. Remove the side Pipe Plug and (top) Vent Plug.
- C. Set the power unit in the horizontal position.
- D. 2-Stage Gearheads: Add approximately 9 oz. (266 ml) of SAE 40W oil through top hole. This should be just enough oil to reach the side Pipe Plug.
3-Stage Gearheads (3261-9, 3261-12, 3261-14): Add approximately 13 oz. (384 ml) of SAE 40W oil through top hole. This should be just enough oil to reach the side Pipe Plug.
- E. Install the side Pipe Plug and (top) Vent Plug.

1)Vent/Oil Fill Plug

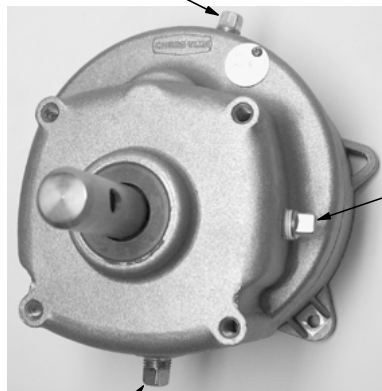

2)Oil Drain Plug

Check the oil level in the gear head at installation

Check the oil level every 6 months

3)Check the oil level at the side plug
If oil is needed use SAE 40W oil

Oil capacity for the 2 stage gear head is 9 oz [266 ml]

Oil capacity for the 3 stage gear head is 13 oz [384 ml]

The oil should be changed every 12 months

1860-22 1/2001

Figure 58. Gearhead Maintenance

Check equipment for loose hardware after the first flock and then every 6 months--including the Anchor Block. Tighten if necessary.

Mechanical Switch Adjustment procedure for Control Units

Refer to See Figure 59.

- A. Turn the adjustment nut counter-clockwise until the switch clicks.
- B. Turn the adjustment nut clockwise until the switch clicks.
- C. Turn the adjustment nut counter-clockwise 3/4 turn.

1) Adjustment Nut

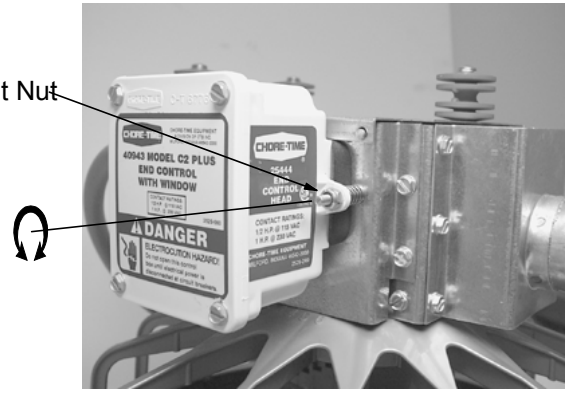

Figure 59. Switch Adjustment

Electronic Sensor Adjustment for Control Units

See Figure 60. The Electron Sensor's sensitivity is preset at the factory. The time delay adjustment is 1 minute to 10 minutes. *The factory setting is 1 minute.* The Sensor also comes with a Safety Timer that can be set to: Off, 1 hour, or 2 hours. *The factory setting is 2 hours.* To get access to the Adjustment Screws:

Step 1: Loosen the Water Tight Connector.

Step 2: Pull the Sensor Down to expose the Safety Timer and Time Delay Adjustment Screws See Figure 60.

Step 3: Adjust the Timer. (See Instructions below).

Step 4: Push the Sensor back up and tighten the Water Tight Connector.

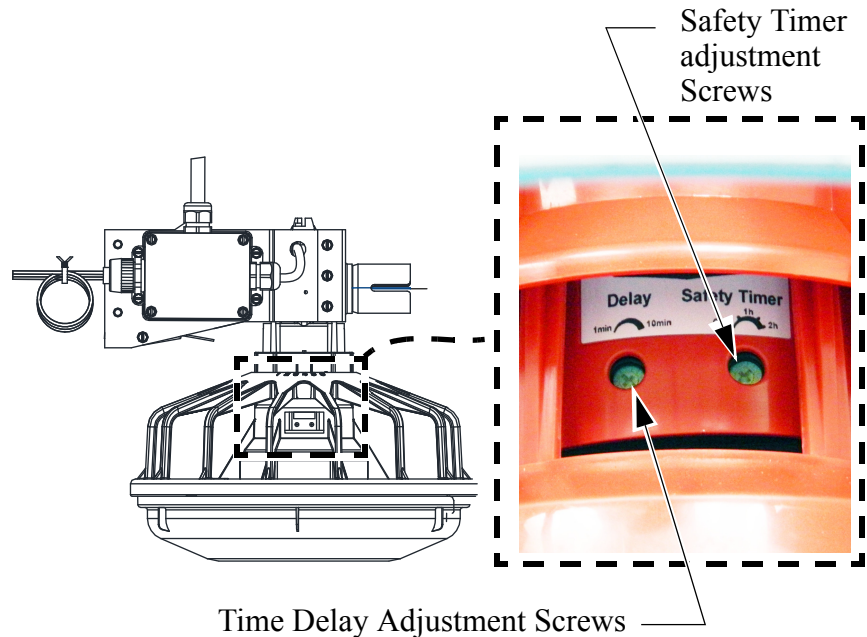

Figure 60. Switch Adjustment

To adjust the Time Delay:

- For less time — turn Time Delay Selector counter-clockwise.
- For more time — turn Time Delay Selector clockwise.

To adjust the Safety Timer:

- If No Safety Timer turn the "Safety Timer" adjustment screw completely **counter** clockwise.
- For a Safety Timer of 1 hour turn the selector **half way** between clockwise and counter clockwise.
- For a Safety Timer of 2 hours turn the selector completely **clockwise**.

•If the Safety Timer is triggered, simply cycle the power off/on to reset the Sensor.

Feeder Line

Keep anti-roost cables tightly stretched. This increases the effectiveness of the electro-guard anti-roost system and keep the pans from being tilted when birds push against them.

Remove all feed from the feeder when there are no birds in the house and when the building is washed and disinfected.

Turn the feeders off prior to removing the birds from the house. This will allow them to clean the feed out of the pans.

If the system is not to be used for an extended period of time, remove all the feed from the feeder lines and feeder pans.

Disconnect power to the system to prevent accidentally starting the system.

If the system must be disassembled, extreme caution must be used to prevent injury from springing auger. Refer to **Figure 61**.

1. Disconnect power to the entire system.
2. Loosen the Tube Clamp on the bearing at the hopper end of the system.
Remove the Tube Clamp and Bearing Retainer.
3. Pull the Anchor and Bearing Assembly and approximately 18" [45 cm] of auger out of the boot.

CAUTION: Stand clear...the auger may spring back into the tube.

BE CAREFUL WHEN WORKING WITH AUGER!

4. Place a clamp or locking plier securely on the auger to prevent it from springing back into the auger boot.
5. Loosen the setscrew in the bearing assembly shaft and remove the Anchor and Bearing Assembly from the auger.

To reinstall the Anchor and Bearing Assembly:

1. Insert the Anchor Assembly into the auger, guide the tip of the auger between the two roll pins in the center of the anchor. Continue to guide the auger until the tip of the auger hits the flat washer. Tighten the setscrews in the center of the anchor until they touch **See Figure 61**.
2. **Carefully** remove the locking pliers while holding onto the Anchor and Bearing Assembly and auger securely.
Slowly ease the auger back into the tube. Use caution. If the auger is allowed to spring back, the bearing race may crack.
Install the Bearing Retainer and fasten with a tube clamp. Keep the Bearing Retainer flush with the end of the anchor for safety.

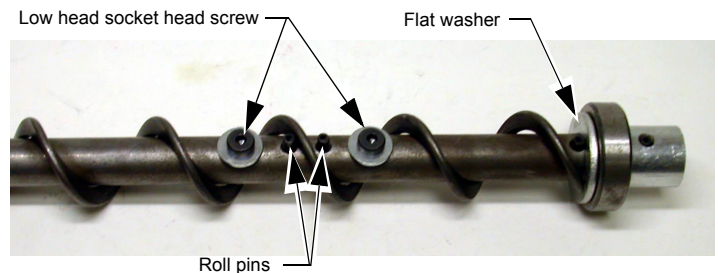
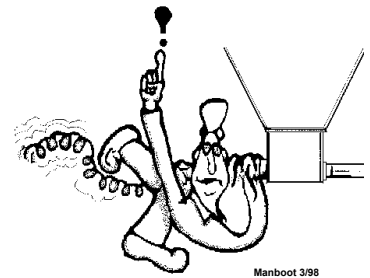

Figure 61. Auger and Anchor Bearing Connection



Power Lift Winch Maintenance

Refer to **Figure 62**.

Grease the winch every 6 months with 1 to 2 shots of common industrial or automotive grease.

Remove any feed build-up in the Safety Switch Boxes in the Control Units.

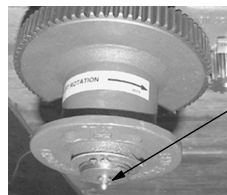

- 1) Grease the Power Lift Winch every 6 months with 1 to 2 shots of common industrial or automotive grease
DO NOT OVER GREASE THE POWER LIFT WINCH

Figure 62. Maintenance to the Power Lift Winch

It may be necessary to periodically retighten the shocker cable. Be sure to disconnect power to the shocker before servicing the equipment.

Management

This section provides you with valuable information concerning feeder operation and management. It is important that you read this information and understand how the feeding system was designed to operate. Once you become familiar with the system, you may *custom operate* it to fit your individual needs.

Initial Start-up of the Feeding System

The Feeding System should be operated prior to birds being housed to make sure the installation is correct, the switches function properly, and to fill the feeder lines with feed.

There are two typical layouts for the feeding system that was determined prior to the installation. Normally if the building is 400' [122 m] or over, a center house hopper set-up is used. See **Figure 63**. For buildings under 400' [122 m], the hopper is placed at one end and the control pan/power unit at the other end. See **Figure 64**.

It is common practice to use partial house brooding during the early days of broiler production. For buildings that have the feeder split in the center (center hopper set-up), normally only the feeders that are in the brood area are used during brood time. For buildings that have the hopper at one end, brooding can be done on the motor end or an optional mid line control pan(s) can be placed on the feeder line.

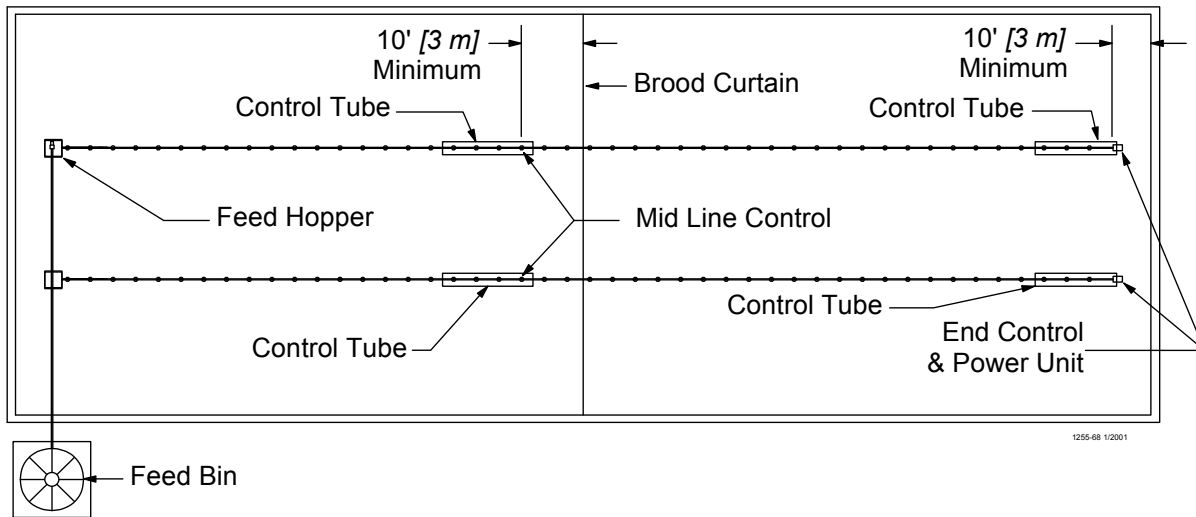

Figure 63.Component location diagram for systems over 400 feet [122 m]. (Top View).

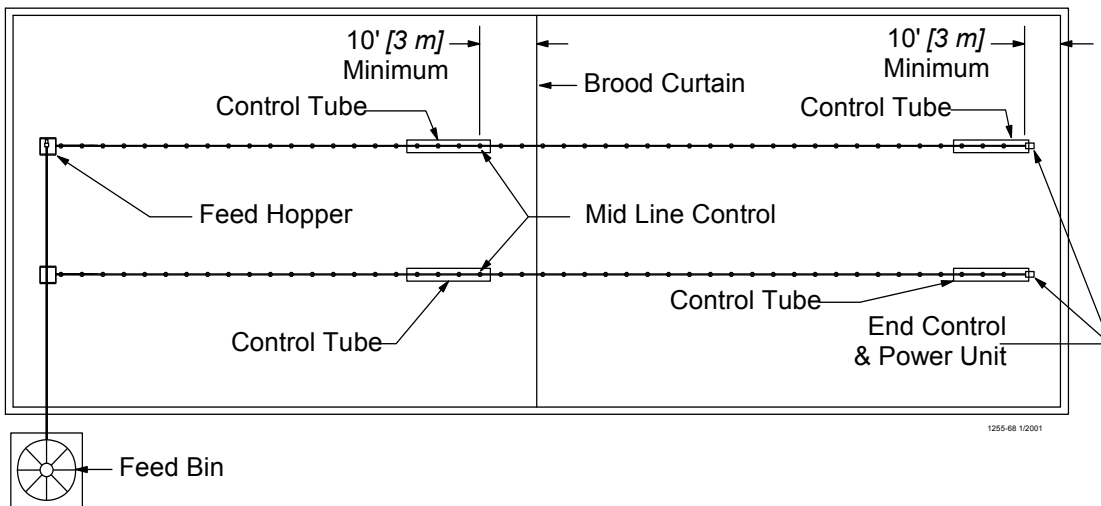

Figure 64.Component location diagram for systems up to 400 feet [122 m]. (Top View).

The feeder tubes and auger are supplied from the factory with a protective oil coating that will cause the system to deliver feed at a reduced rate. The oil coating will also create a larger load on the power unit (motor) until the system has been initially purged with feed, and becomes broken in.

To operate

1. Lower feeder lines so the feed pans are resting on the floor and the feed flood windows are completely open. Although the major weight of the feeder lines will be on the floor, do not remove all the weight from the suspension system and allow the cables to become slack.
2. Apply power to the feeder lines to check the operation. Allow to operate empty for 1-2 minutes.

NOTE: For feeder lines that have mid line controls, the recommended bypass switch(s) are wired into the system for selection of partial or full house control. Select the switch so the mid line control is functional. As the feeder operates, the feed will stop at the mid line control pan.

3. With the shut-off slide on the feed bin boot closed, energize the Flex-Auger® fill system. After operation of approximately 1-2 minutes, open the boot slide 1/2 way to allow feed to be conveyed to the feeders.
4. Once feed begins to be dispensed into the feed hopper(s), manually shut-off the fill system.
5. Apply power again to the feeder lines. Operate the fill system manually to dispense approximately 50 lb. [23 kg] increments of feed into the feed hopper(s). Allow the feed hopper to become empty for 30 seconds between each increment to reduce load on the feeder motor. Continue this procedure until feed has been dispensed to all the feeder pans. When the feed reaches the control pan, the feeder line will be shut-off.
6. Once the feeder lines have been initially filled with feed, manually dispensing feed in 50 lb. [23 kg] increments will no longer be necessary. The shut-off slide on the Flex-Auger® fill system may be completely opened. Refer to the Flex-Auger fill system Operator's Manual for information when multiple feed bins are used.

General Operation of the MODEL C2® PLUS and MODEL G™ PLUS Feeders

These recommendations are the guideline to aid producers with the use of the feeding system. With experience a feeding program will be developed to enhance the feeding systems performance. Several factors such as feed content, type of birds, climate, lighting programs, and etc. may dictate change from these recommendations.

The MODEL C2 PLUS and G PLUS feeders have a feed flood windows which allows the feeder pan, when lowered to the floor, to be filled with feed for the brooding of young birds. Start young birds with the feeder line lowered so the feed pans are resting on the floor and the feed flood windows are completely open. Although the major weight of the feeder lines will be on the floor, do not remove all the weight from the suspension system and allow the cables to become slack.

It is advisable to provide supplemental feed during the first few days for the young birds. This is especially true when partial house brooding is used (refer to page 40). Supplemental feeders such as the CHORE-TIME® E-Z START™ Chick Feeder, provide extra feeding space and access to the feed.

With the feeders lowered to the floor and the feed flood windows open, the operation of the feeder will allow a high level of feed to be placed into the feed pans making it easy for the birds to find feed, adapt to the feeder, and begin to eat.

Do not operate the feeding system on automatic (full demand feed) when the feed windows are open. Chore-Time recommends opening the feed windows for the first 8 to 14 days. The feeders will need to be operated at least 2 times a day for the first 5 days, and thereafter, 3 times a day or more as needed, while the windows are open. If it is not possible to operate the feeder manually 1-3 times a day during the brood time (windows open), then a time clock should be utilized to limit the number of times and length of time the feeder can operate. Failure to do one of the above will create the possibility of an excessive high feed level in the feed pans and the birds to waste feed.

DO NOT OPERATE THE FEEDING SYSTEM ON AUTOMATIC (FULL FEED) WHEN THE FEED WINDOWS ARE OPEN.

As the birds grow and become acclimated to the feeder pans, the feeder will need to be raised to the grow-out position. Before raising the feeder, it is recommended to allow the birds to eat the feed level down below the feed flood windows. This will ease the process of the feed flood windows closing properly.

Use the suspension system to raise the feeder(s) line. As the feeder is raised the feed flood windows will close. Continue raising the feeder lines until the feed pans just begin to clear the floor or litter.

IMPORTANT: When raising the feeder to the grow-out position, make sure the feed pans are to the point of just clearing the floor.

This will insure the feed will properly flow out into the feeder pan. When the feeder is raised to just clear the litter, there may be a few places where the litter is lower and the pans seem too high. Do not be concerned as the birds will level the litter and at this young bird age, there will be sufficient feeder space.

The feeder should be set on the #4 position for most applications. The adjustment settings are easy to understand and change. Setting numbers are embossed on both sides of the grill so they may be easily seen from either side of the feeder line. See **Figure 65.**

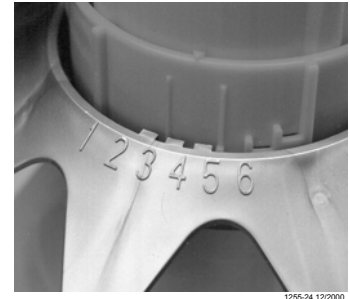

Figure 65. Feeder Pan Assembly adjustment

Feed texture and consistency, type of bird, or other variables may make it necessary to change to another feed setting position. The combination of proper pan height, feeder setting, and feeder operation will result in optimum feeder performance (refer to **Figure 66.** for pan height information). The operator will learn what performs best for his/her situation with experience.

End Control and Mid Line Control Pans

At installation time, the end control pan of the feeder was placed to be 10 feet [3 m] from the end of the building to allow the birds access around the end of the feeder line. It is important the feed setting of the end control pan be the same as the rest of the feeder pans so the birds activate the feeder.

The Mid Line Control is placed on the feeder line when partial house brooding is desired. It is important the mid line control be installed at least 2 feeder pans away from the curtain or partition so the birds will activate the feeder line. The feed setting for the mid line control should be the same as the rest of the feeder pans on the feeder line. A toggle switch or disconnect is used to bypass the power to the mid line control. This allows the mid line control to serve as a standard feeder after brooding. The feeder can be changed from full house operation to partial house brooding with the activation of the switch.

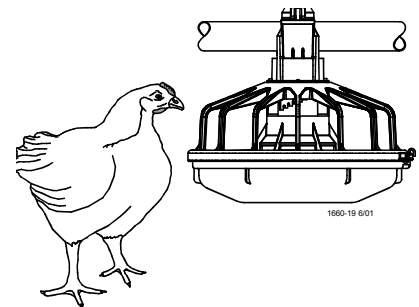

Figure 66. Feeder Pan Assembly height adjustment

Controlling the Feeders (optional equipment)

A time clock control is used with the feeding system to reduce excessive feeder operation time and limit feed wastage. The basic use of a time clock control is to allow periods of time during the day for the birds to reduce the feed level in the feeder pans and to limit the possibility of the birds creating a high feed level and wasting feed. This is not to be confused with lighting programs that have become very common place. If lighting or intermittent lighting programs are to be used, the use of the time clock control will be limited to just the light period. **Caution should be used to not restrict the feed from the birds during the light period.** Experience with the feeding system will determine how the time clock control is used.

The MODEL C2 PLUS and G PLUS Feeding Systems may be controlled by the #34385 Control Panel or the #34574 Time Clock Control. Refer to the instructions supplied with each control for information.

Electro-guard Operation

The electro-guard chargers should be operated on a separate electrical circuit so the anti-roost system can be shut off using a switch next to the entrance door when someone enters the building. Birds are less likely to become wild and flighty if the anti-roost is off when people are in the building.

Parts List

150# Plastic Hopper

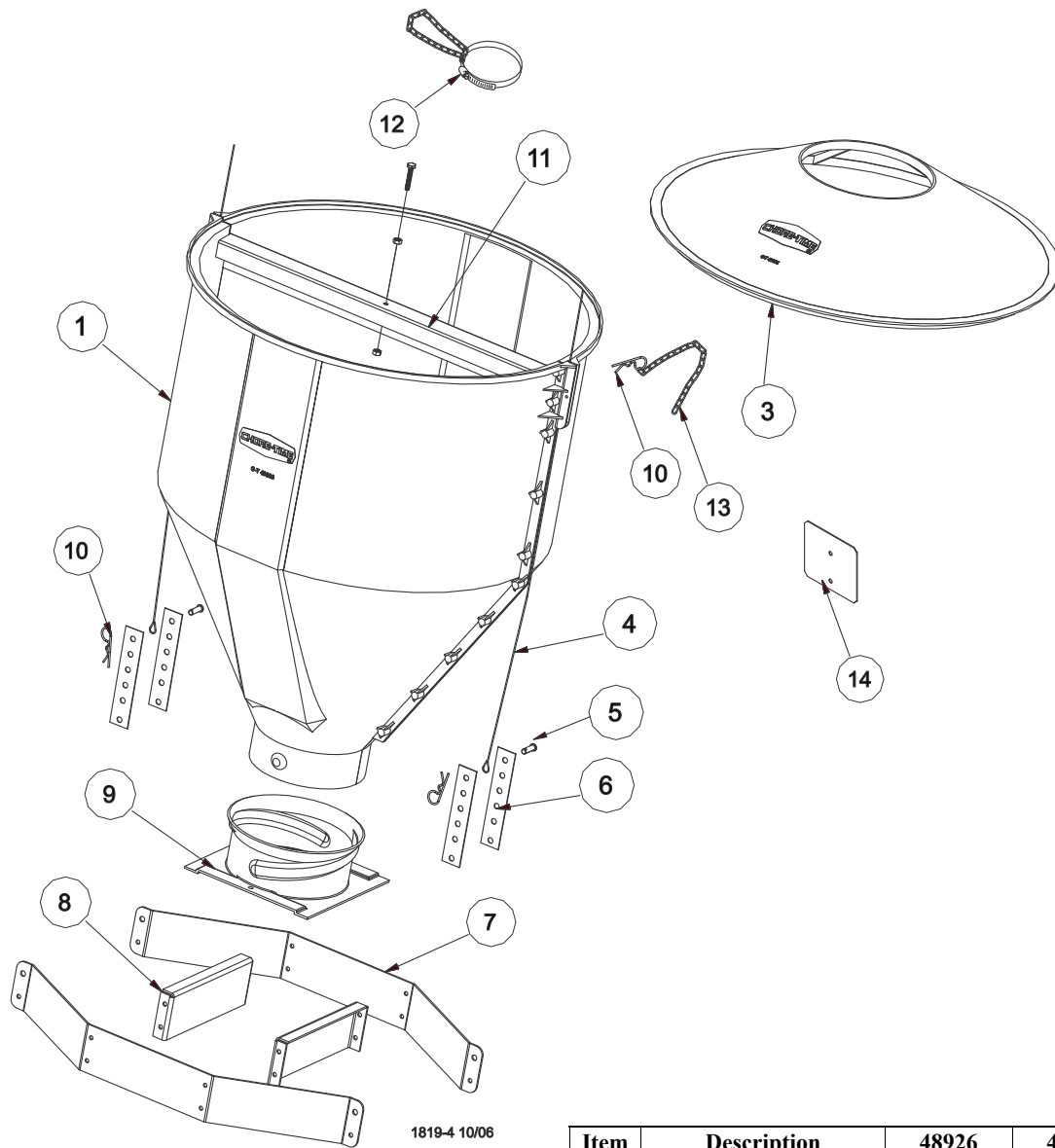

1819-4 10/06

Item	Description	48926 Hopper Kit	49267 Hopper Kit
1	Switch Backup Plate	50966	50966
2	Plastic hopper half	49028	49028
3	Hopper cover	--	48675
4	Support cable assembly	2809-3	2809-3
5	Clevis pin	2797-1	2797-1
6	Boot adjuster bracket	2706	2706
7	Suspension angles	48679	48679
8	Suspension brace	48680	48680
9	Twist lock collar	49041	49041
10	Hair pin	2664	2664
11	Cross brace	49029	49029
12	Drop tube support	14367	14367
13*	Chain	2128	2128

*Item must be ordered in either 100 ft or 250 ft quantities, 2128-100 is 100 ft and 2128-250 is 250 ft.

200# Hopper Components

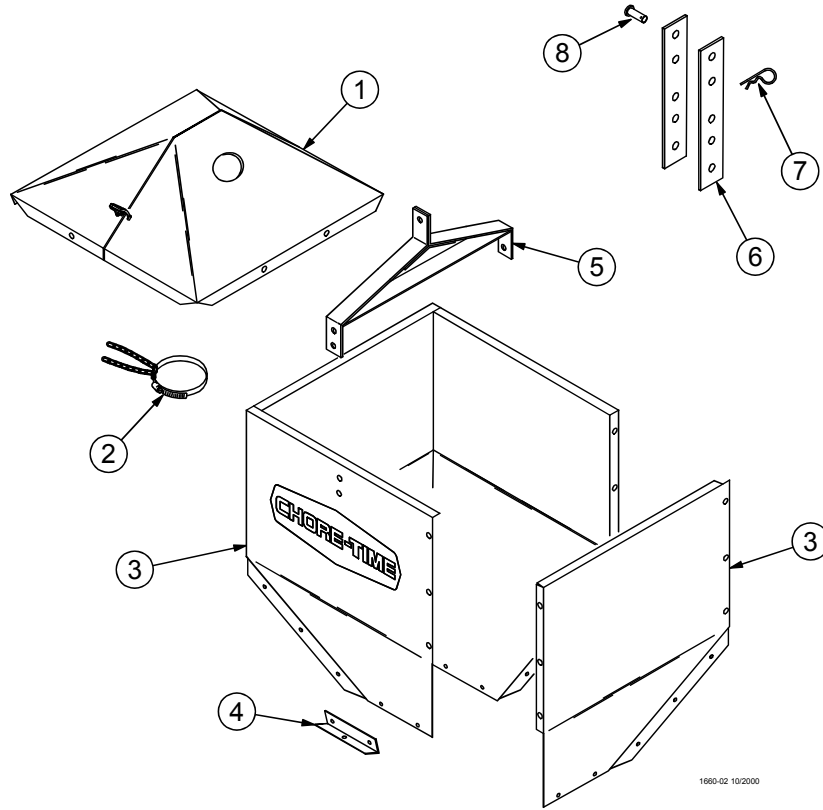

Item	Description	Part No.
1*	Hopper Cover (optional)	28206
2	Tube Support Assembly	14367
3	Hopper Side	2680
4	Boot Hanger	2671
5	Hanger Bracket Assembly	2681
6	Adjustment Bracket	2706
7	Hair Pin	2664
8	Clevis Pin, 5/16 x 1"	2797-1

*Hopper Cover not included. Must be ordered separately.

The 200# Hopper Assembly may be ordered under Part No. 7941. Hopper Cover must be ordered separately.

100 # Hopper Components

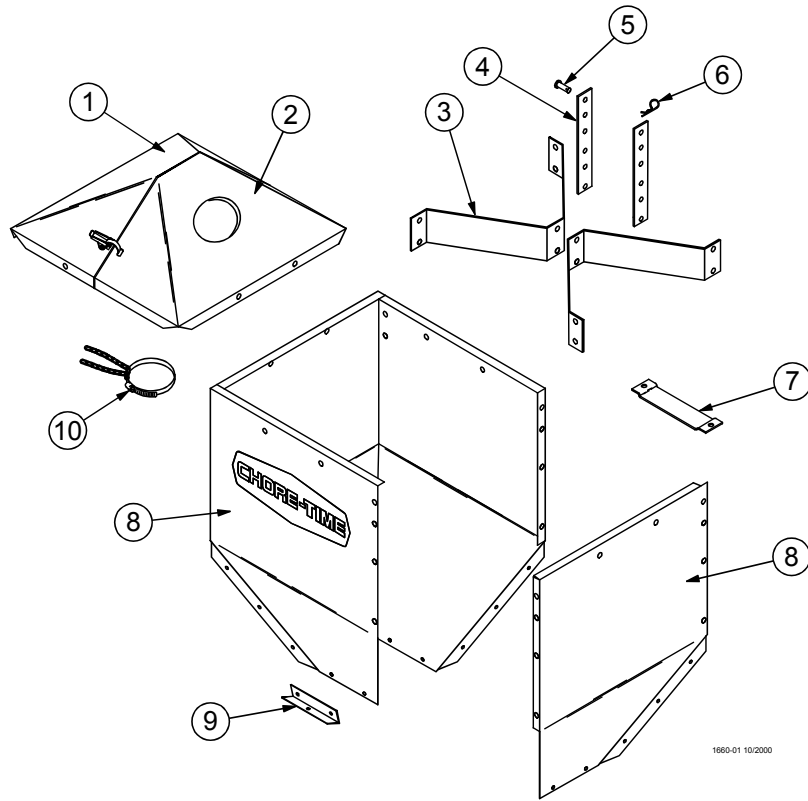

Key	Description	Part No.
1*	Hopper Cover (w/o hole)	28211
2*	Hopper Cover (w/ hole)	28212
3	Hopper Hanger	28165
4	Adjustment Bracket	2706
5	Clevis Pin, 5/16" x 1"	2797-1
6	Hair Pin	2664
7	H.L.C Mounting Bracket	28267
8	Hopper Side (w/ hole)	24241
9	Boot Hanger	28168
10	Tube Support Assembly	14367

*These components may be ordered as an assembly under Part No. 28210.

The 100# Hopper Assembly may be ordered under Part No. 28220.

The 100# Hopper Assembly, including the Cover, may be ordered under Part No. 28240.

Hopper Mount Bracket (Optional)

Part Number 49358 - Hopper Suspension Kit

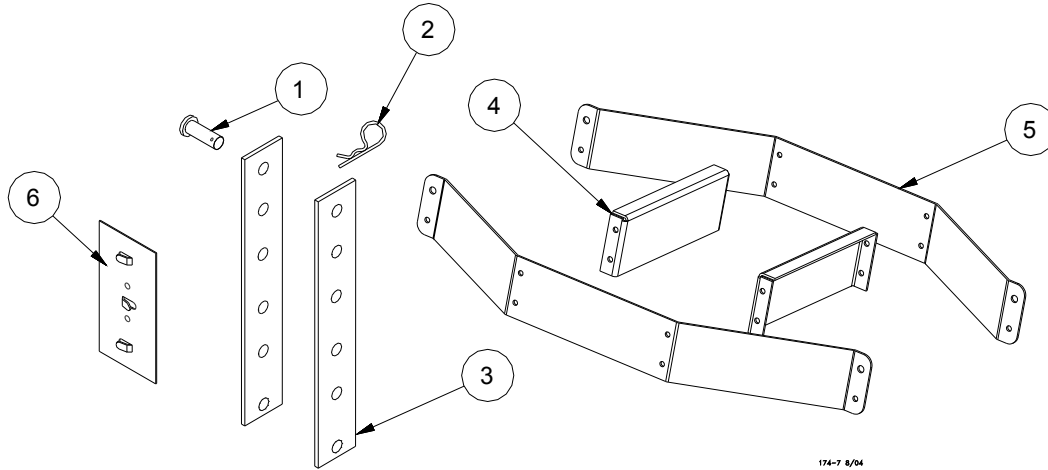

Item	Description	Part No. Single Boot Kit	Part No. Twin Boot Kit
1	Clevis Pin, 5/16" x 1"	2797-1	2797-1
2	Adjustment Bracket	2706	2706
3	Hair Pin	2664	2664
4	Suspension Brace	48680	48680
5	Suspension Angle	48679	48679
6	Cable Guide	34573	34573

Single Boot Components Part No. 6822

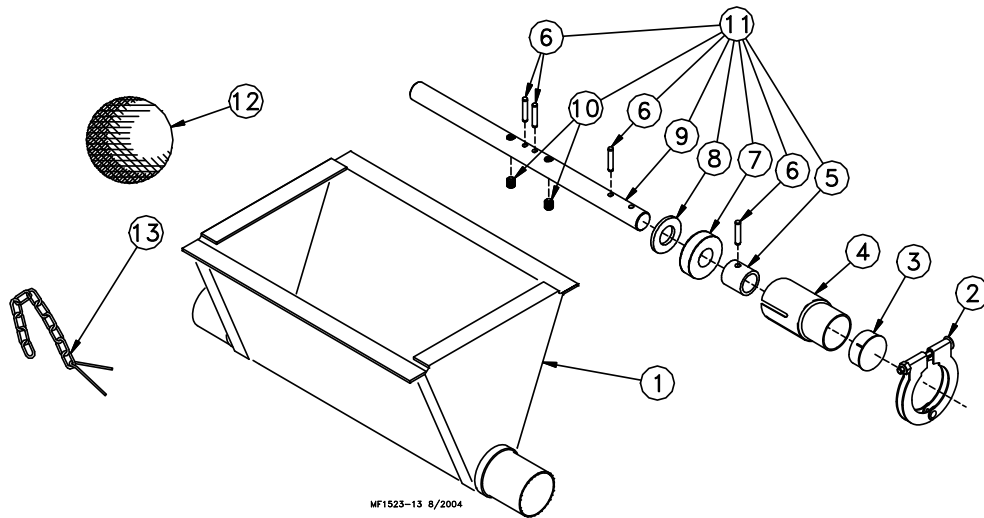

Item	Description	Part No.
1	Boot Weldment	3760
2	Tube Clamp	24063
3	Cap	29373
4	Outlet Tube	4556
5	Sleeve	5648
6	3/16 x 1" Pin	2960-1
7	Bearing	2689
8	Washer	2955-14

Item	Description	Part No.
9	Anchor	38540
10	Setscrew	47867
11	Anchor and Bearing Ass'y	39372
12	Cannonball	3531
13	Latch Pin Ass'y	2683
--	Danger Decal	2527-9

Twin Boot Components Part No. 6824

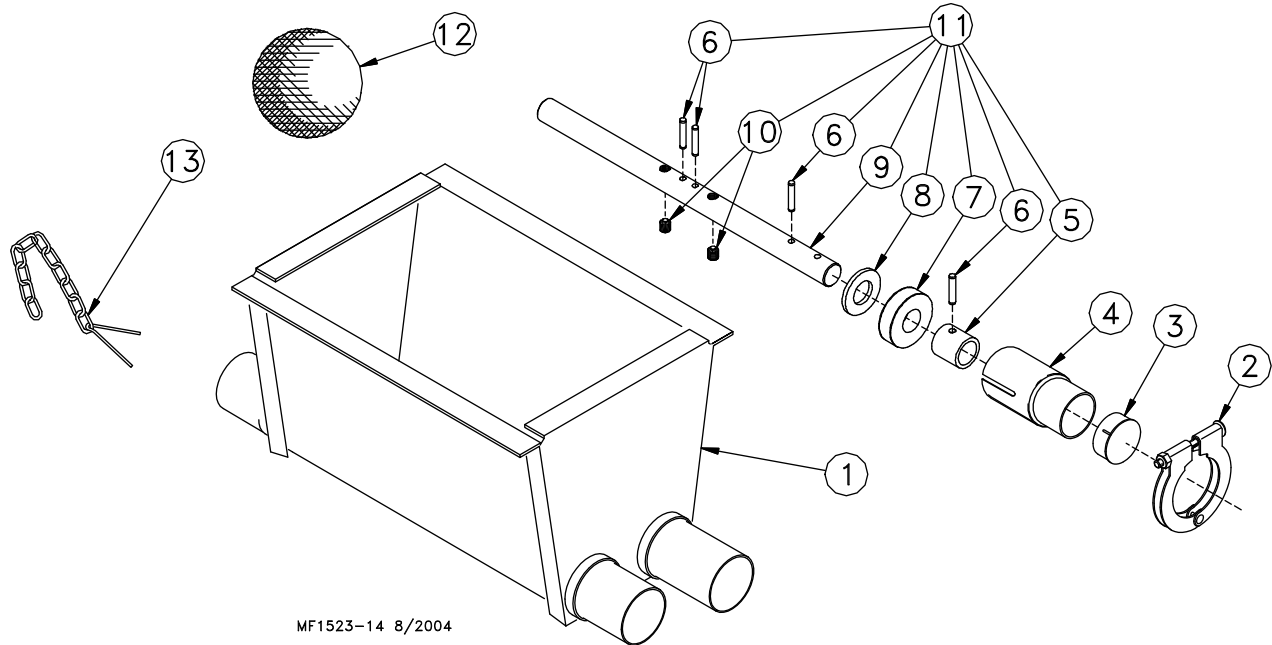

MF1523-14 8/2004

Item	Description	Part No.
1	Boot Weldment	3932
2	Tube Clamp	24063
3	Cap	29373
4	Outlet Tube	4556
5	Sleeve	5648
6	3/16 x 1" Pin	2960-1
7	Bearing	2689
8	Washer	2955-14
9	Anchor	38540

Item	Description	Part No.
10	Setscrew	47867
11	Anchor and Bearing Ass'y	39372
12	Cannonball	3531
13	Latch Pin Ass'y	2683
--*	Jumper Wire Kit	5960
--	Danger Decal	2527-9

*The Jumper Wire Kit includes an insulated piece of High-Voltage Wire (part no. 28994) and (2) cable clamps.

Feeder Line Components

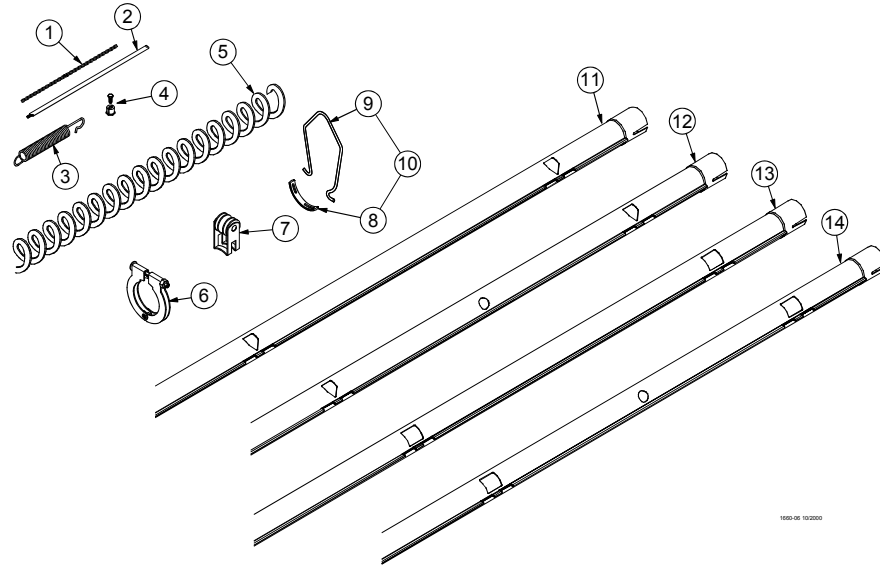

Item	Description	Part No.
1	1/16" Cable	1922
2	Charger Wire (165') Charger Wire (330')	28994-165 28994-330
3	Spring	7551
4	1/16" Cable Clamp	1826
5*	Auger	6820-0
6	Tube Clamp	24063
7	Anti-Roost Bracket	24060
8	Hanger Bracket	7297
9	Hanger Strap	7298
10	Hanger Kit	7299
11	Standard Feeder Tube-1 3/4" Roll Form - 9', 4 Hole Tube - 10', 3 Hole Tube - 10', 4 Hole Tube - 12', 3 Hole Tube - 12', 4 Hole Tube - 12', 5 Hole Tube	6854-1 6854-5 6854-4 6854-8 6854-7 6854-6
12	Standard Feeder Tube-1 3/4" with Chick Holes (EZ. Holes) - 9', 4 Hole, 4 EZ. Holes - 10', 4 Hole, 4 EZ. Holes - 12', 4 Hole, 4 EZ. Holes - 12', 5 Hole, 5 EZ. Holes - 10', 3 Hole, 3 EZ. Holes - 9', 4 Hole, 2 EZ. Holes - 10', 4 Hole, 2 EZ. Holes - 12', 4 Hole, 2 EZ. Holes	6854-15 6854-16 6854-17 6854-18 6854-19 6854-20 6854-21 6854-22
13	Control Feeder Tube-1 3/4" Roll Form - 9', 4 Hole Tube - 10', 4 Hole Tube - 10', 3 Hole Tube - 12', 3 Hole Tube - 12', 4 Hole Tube - 12', 5 Hole Tube	43006-1 43006-4 43006-5 43006-8 43006-7 43006-6
14	Control Feeder Tube-1 3/4" with Chick Holes (EZ. Holes) - 9', 4 Hole, 4 EZ. Holes - 10', 4 Hole, 4 EZ. Holes - 12', 4 Hole, 4 EZ. Holes - 12', 5 Hole, 5 EZ. Holes	43006-15 43006-16 43006-17 43006-18

*Round up to the nearest 10'. Auger lengths from 50' to 500'. Example: 6820-200 would be a 200' roll of 6820 Auger.

C2 PLUS Standard with Two Piece Top

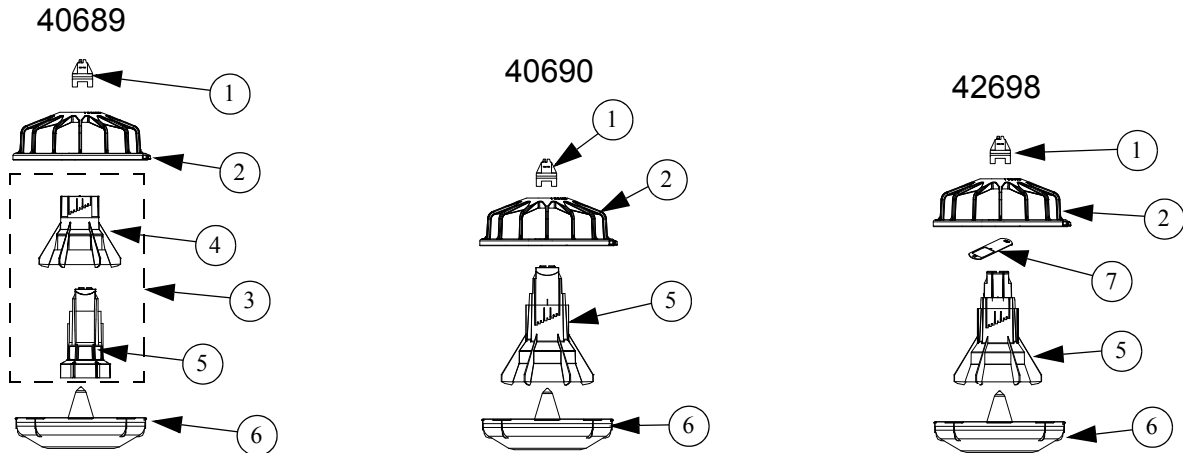

Model Number		40689 C2 PLUS with Removable Top	40690 C2 PLUS Non Window Removable Top	42698 C2 PLUS Non Window with Slide Shut-Off
Item	Description	Part No.		
1	Slide Top Cap	38603	38603	38603
2	C2 PLUS Grill	39567	39567	39567
3	Cone Assembly (Packed)	44346	-	-
4	Adjustment Cone	38604	-	-
5	C2 PLUS Cone	44352	39565	42705
6	Feeder Pan	38600	38600	38600
7	Shut-Off Slide	-	-	39564

C2 PLUS Standard with One Piece Top

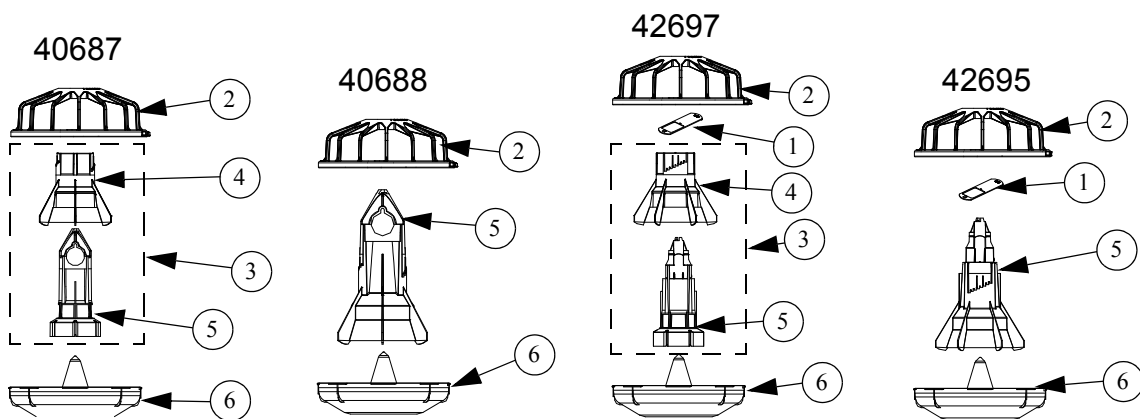

Model Number		40687 C2 PLUS with Windows	40688 C2 PLUS Non Window	42697 C2 PLUS Non Window with Slide Shut-Off	42695 C2 PLUS
Item	Description	Part No.			
1	Shut-Off Slide	-	-	39564	39564
2	C2 PLUS Grill	39567	39567	39567	39567
3	Cone Assembly (Packed)	41187	-	42702	
4	Adjustment Cone	38604	39566	38604	
5	Cone	38601	-	42701	42706
6	Feeder Pan	38600	38600	38600	38600

MODEL C2 PLUS Shallow with Two Piece Top

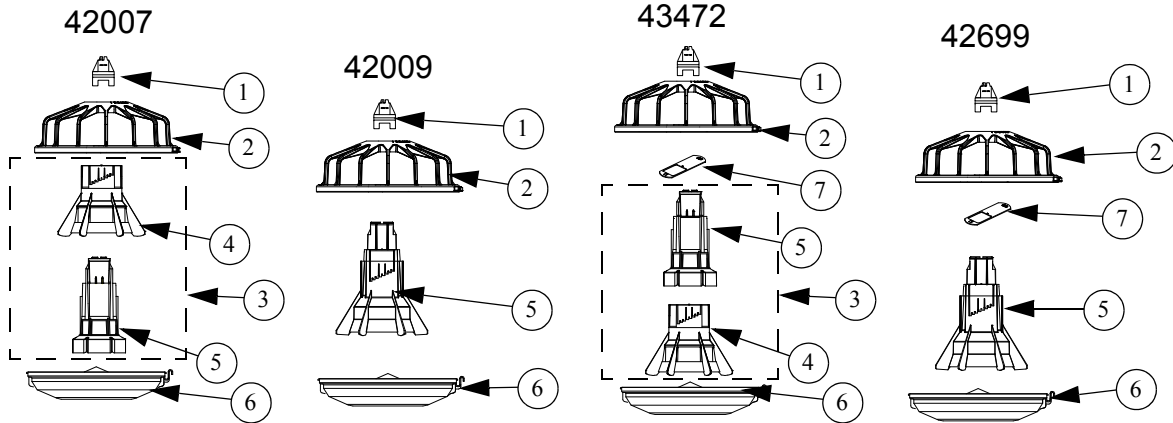

Model Number		42007 C2 PLUS Shallow W Window & Removable Top	42009 C2 PLUS Shallow Non Window & Removable Top	43472 C2 PLUS Shallow Non Window Removable Top with Slide Shut-Off	42699 C2 PLUS Shallow Non Window with Slide Shut-Off
Item	Description	Part No.			
1	Slide Top Cap	38603	25052	38603	25022
2	C2 PLUS Grill	39567	39567	39567	39567
3	Cone Assembly (Packed)	42011	-	43471	-
4	Adjustment Cone	41504	-	41504	-
5	C2 PLUS Cone	41503	41892	42238	42677
6	Feeder Pan	41500	41500	41500	41500
7	Shut-Off Slide	-	-	39564	39564

C2 PLUS Shallow with One Piece Top

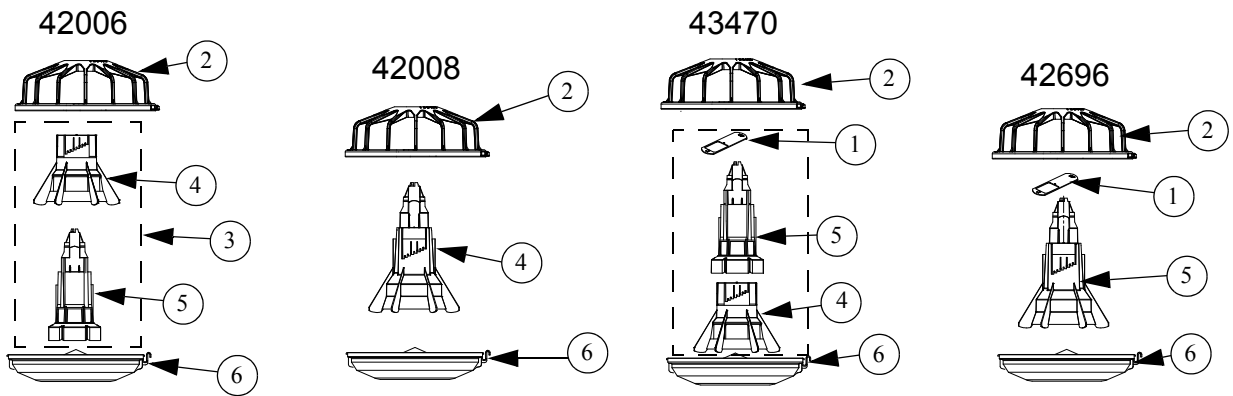

Model Number		42006 C2 PLUS Shallow Removable Top	42008 C2 PLUS Shallow Non Window Removable Top	43470 C2 PLUS Shallow Non Window with Slide Shut-Off	42696 C2 PLUS Shallow Non Window with Slide Shut-Off
Item	Description	Part No.			
1	Shut-Off Slide	-	-	39564	39564
2	C2 PLUS Grill	39567	39567	39567	39567
3	Cone Assembly (Packed)	42010	-	43469	-
4	Adjustment Cone	41504	-	41504	-
5	C2 PLUS Shallow Cone	41502	41505	42237	42678
6	Shallow Feeder Pan	41500	41500	41500	41500

MODEL C2 PLUS and G PLUS with Extended Fins

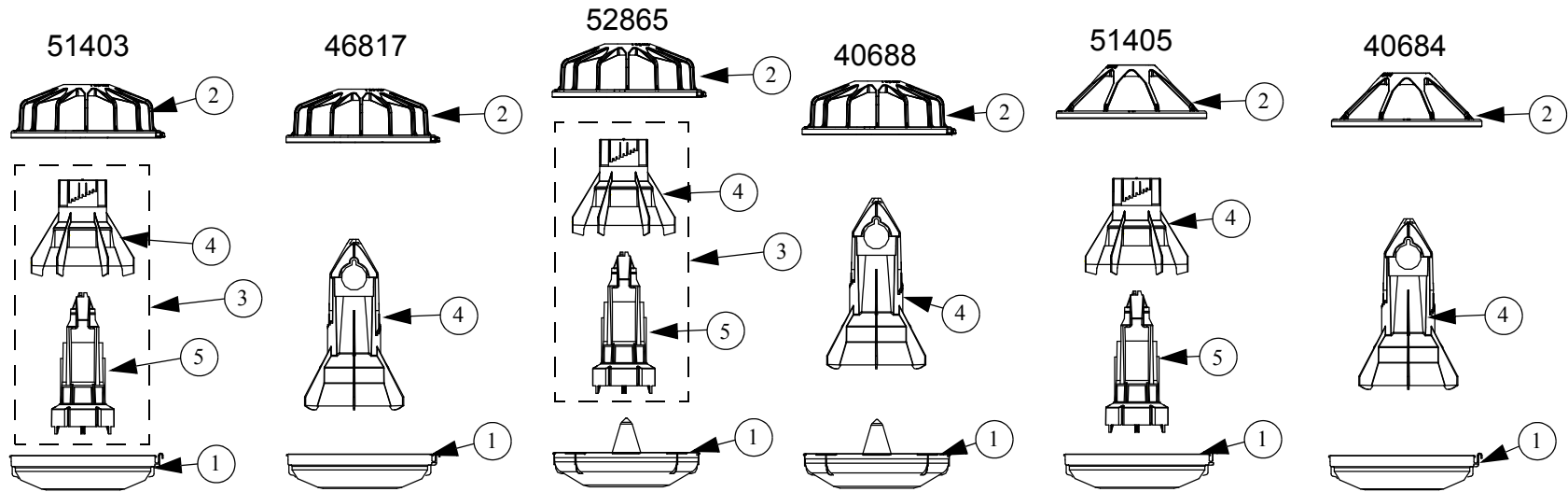

Model Number		51403 MODEL C2 and G PLUS Extended	46817 MODEL C2 and G PLUS Extended	52865 MODEL C2 and G PLUS Extended	40688 MODEL C2 and G PLUS Extended	51405 MODEL C2 and G PLUS Extended	40684 MODEL C2 and G PLUS Extended
Item	Description	Part No.					
1	Feeder Pan	41501	41501	38600	38600	41501	41501
2	C2 PLUS Grill	39567	39567	39567	39567	38599	38599
3	Cone Assembly (Packed)	51415	-	51415	-	51415	
4	Adjustment Cone	51406	39566	51406	39566	51406	39566
5	C2 PLUS Shallow Cone	51404	-	51404	-	51404	

MODEL G PLUS Standard with Two Piece Top

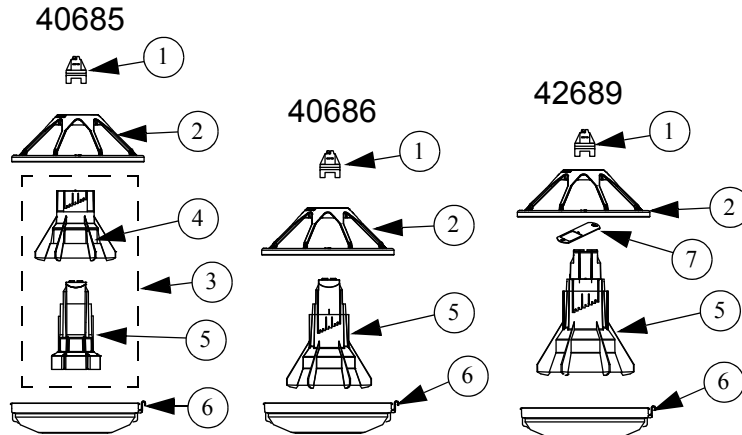

Model Number		40685 MODEL G PLUS with Removable Top	40686 MODEL G PLUS Non Window Removable Top	42689 MODEL G PLUS Non Window with Slide Shut-Off
Item	Description	Part No.		
1	Slide Top Cap	38603	38603	25052
2	MODEL G PLUS Grill	38599	38599	38599
3	Cone Assembly (Packed)	44346	-	-
4	Adjustment Cone	38604	-	-
5	C2 PLUS Cone	44352	39565	42705
6	Feeder Pan	41501	41501	41501
7	Shut-Off Slide	-	-	39564

MODEL G PLUS Standard with One Piece Top

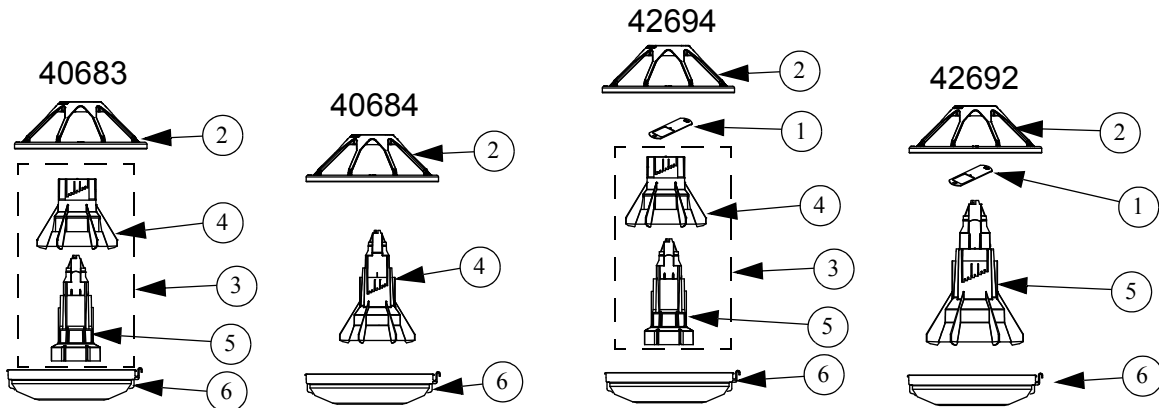

Model Number		40683 MODEL G PLUS with Window	40684 MODEL G PLUS Non Window	42694 MODEL G PLUS Window with Slide Shut-Off	42692 MODEL G PLUS Non Window with Slide Shut-Off
Item	Description	Part No.			
1	Shut-Off Slide	-	-	39564	39564
2	MODEL G PLUS Grill	38599	38599	38599	38599
3	Cone Assembly (Packed)	41187	-	42702	
4	Adjustment Cone	38604	39566	38604	
5	C2 PLUS Cone	38601	-	42701	42706
6	Feeder Pan	41501	41501	41501	41501

MODEL G PLUS Shallow with Two Piece Top

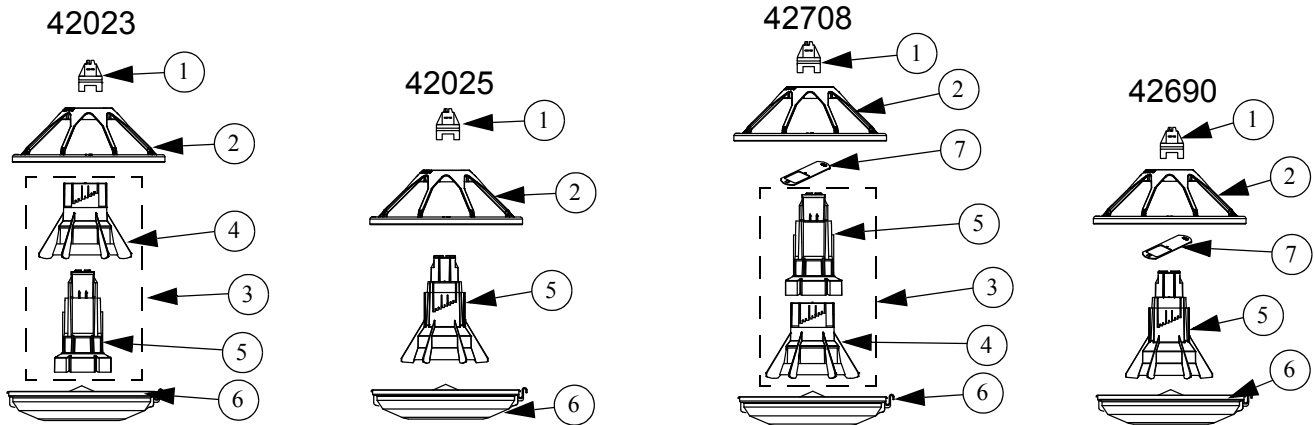

Model Number		42023 MODEL G PLUS Shallow with Window & Removable Top	42025 MODEL G PLUS Shallow with Non Window & Removable Top	42708 MODEL G PLUS Shallow with Window & Slide Shut-Off	42690 MODEL G PLUS Shallow Non Window with Removable Top & Slide Shut-Off
Item	Description	Part No.			
1	Slide Top Cap	38603	25052	38603	25052
2	MODEL G PLUS Grill	38599	38599	38599	38599
3	Cone Assembly (Packed)	42011	-	43471	-
4	Adjustment Cone	41504	-	41504	-
5	C2 PLUS Cone	41503	41892	42238	42677
6	Shallow Feeder Pan	41500	41500	41500	41500
7	Shut-Off Slide	-	-	39564	39564

MODEL G PLUS Shallow with Two Piece Top

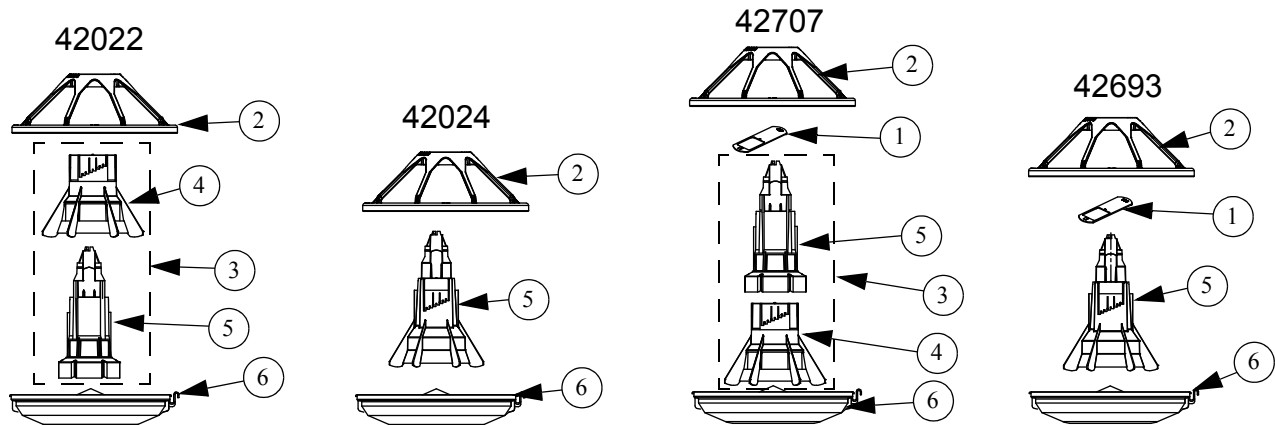

Model Number		42022 MODEL G PLUS Shallow with Windows	42024 MODEL G PLUS Shallow Non Window	42707 MODEL G PLUS Shallow with Window & Slide Shut-Off	42693 MODEL G PLUS Shallow Non Window with Slide Shut-Off
Item	Description	Part No.			
1	Shut-Off Slide	-	-	39564	39564
2	MODEL G PLUS Grill	38599	38599	38599	38599
3	Cone Assembly (Packed)	42010	-	43469	-
4	Adjustment Cone	41504	-	41504	-
5	C2 PLUS Cone	41502	41505	42237	42678
6	Shallow Feeder Pan	41500	41500	41500	41500

Power Unit Assemblies

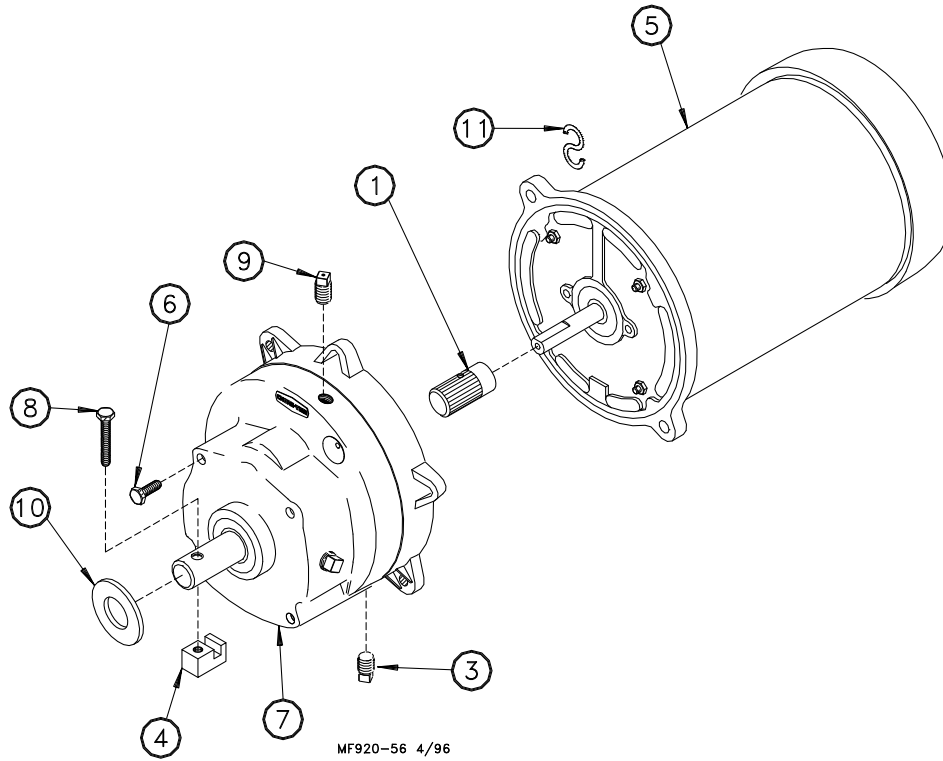

Item	Description	3259-84 Part No.	3259-85 Part No.	3259-98 Part No.	3259-100 Part No.	3259-128 Part No.
1	Pinion Assembly	5046	5046	5046	5046	5046
2	----	----	----	----	----	----
3	Pipe Plug (magnetic)	30160	30160	30160	30160	30160
4	Driver Block	4642	4642	4642	4642	4642
5	Motor	4229	5703	5977	28031	24624
6	5/16-18x5/8 Hex HD Screw	4412-1	4412-1	4412-1	4412-1	4412-1
7	Gearhead	3261-5	3261-5	3261-11	3261-11	3261-5
8	1/4-20x1-1/2 Socket Hd Screw	5083-8	5083-8	5083-8	5083-8	5083-8
9	Vent Plug	3516	3516	3516	3516	3516
10	Flat Washer	1484	1484	1484	1484	1484
11	"S" Hook	2805	2805	2805	2805	2805
--	Cord Assembly	----	----	28028	----	----
--	Connector (Romex)	----	----	----	----	----
--	Connector (90 Degree)	----	----	4228	----	----

Power Unit Assembly Part Numbers:

Part No.	HP	RPM	Phase	Hz	Voltage	Usages
3259-84	1/3 HP	348 RPM	Single Phase	60 Hz	230	
3259-85	1/2 HP	348 RPM	Single Phase	60 Hz	230	
3259-98	1/2 HP	348 RPM	Single Phase	50 Hz	230	Use with all Control Units
3259-100	1/2 HP	348 RPM	Three Phase	50 Hz	220/380	Use with all Control Units
3259-128	1/2 HP	348 RPM	Three Phase	60 Hz	230	Use with all Control Units

Mechanical End Control

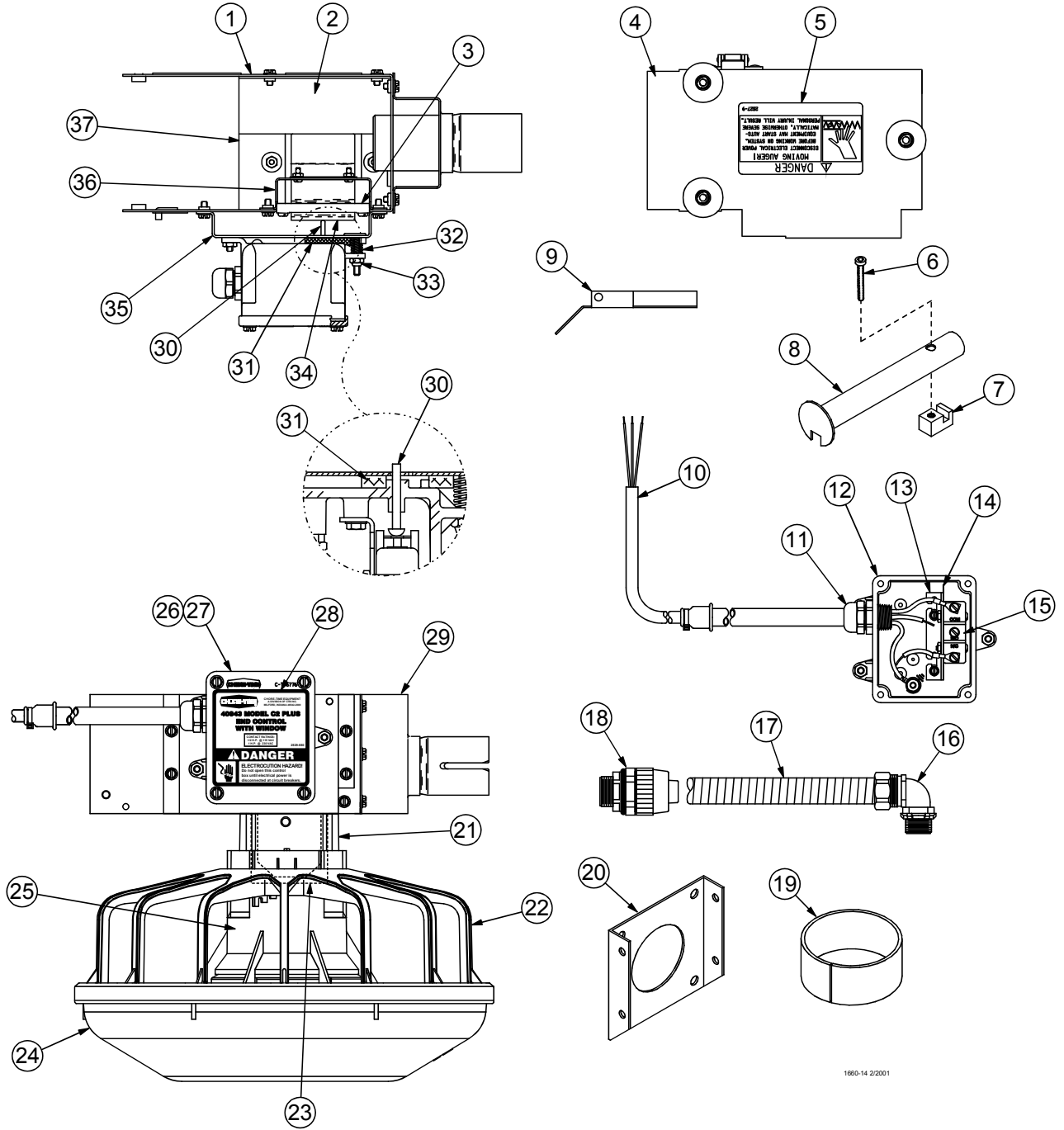

1660-14 2/2001

Item	Description	MODEL C2 PLUS Standard Part No. 40943	MODEL C2 PLUS Shallow Part No. 42012	MODEL GPLUS Standard Part No. 40944	MODEL G PLUS Shallow Part No. 42028
1	Control Body	14434	14434	14434	14434
2	Deflector Panel	41363	41363	41363	41363
3	Paddle Retainer	25045	25045	25045	25045
4	Control Cover Assembly	24682	24682	24682	24682
5	Danger Decal	2527-9	2527-9	2527-9	2527-9
6	1/4-20x1-1/2 Socket Hd Screw	5083-8	5083-8	5083-8	5083-8
7	Driver Block	4642	4642	4642	4642
8	Drive Tube Weldment	44794	44794	44794	44794
9	Bottom Cover	14432	14432	14432	14432
10	Control Cord Assembly	25495	25495	25495	25495
11	1/2" Liquid Tight Connector	24685	24685	24685	24685
12	Switch Box	24702	24702	24702	24702
13*	Switch Bracket	46122	46122	46122	46122
14*	Switch Insulation	1907-5	1907-5	1907-5	1907-5
15**	Actuator Switch	46091	46091	46091	46091
16	1/2" Liquid Tight Connector	23810	23810	23810	23810
17	14" Flexible Conduit	26982-1	26982-1	26982-1	26982-1
18	Straight Liquid Tight Connector	26980	26980	26980	26980
19	Cut Sleeve	43110	43110	43110	43110
20	Anchor Plate	4188	4188	4188	4188
21	Center Support Assembly	40947	37371	40947	37371
22	Feeder Grill	39567	39567	38599	38599
23	Mylar Assembly	25318	25318	25318	25318
24	Feeder Pan	41501	41500	41501	41500
25	Adjustment Cone	38604	41504	38604	41504
26	Switch Box Cover	6776	6776	6776	6776
27	Switch Box Gasket	6777	6777	6777	6777
28	Danger/Product Identification Decal	2529-660	2529-697	2529-659	2529-698
29	Support Bracket	24683	24683	24683	24683
30	Spring	6972	6972	6972	6972
31	#10-32 Lock Nut	6963	6963	6963	6963
32	Paddle	46123	46123	46123	46123
33	Gasket	6968-1	6968-1	6968-1	6968-1
34	Actuator Pin	8757	8757	8757	8757
35	Switch Box Mount	25084	25084	25084	25084
36	Stop Panel	25433	25433	25433	25433
37	Switch Bracket	40749	40749	40749	40749
--	Anti-Roost Guard	2798	2798	2798	2798
--	Parts Package	40809	40809	40809	40809

*These items are included in the Parts Package.

**Actuator Switch, Chore-Time part number 7114, is no longer available. When replacing, use 7114 Switch Replacement Kit Part Number 46678.

Mechanical Mid Line Control

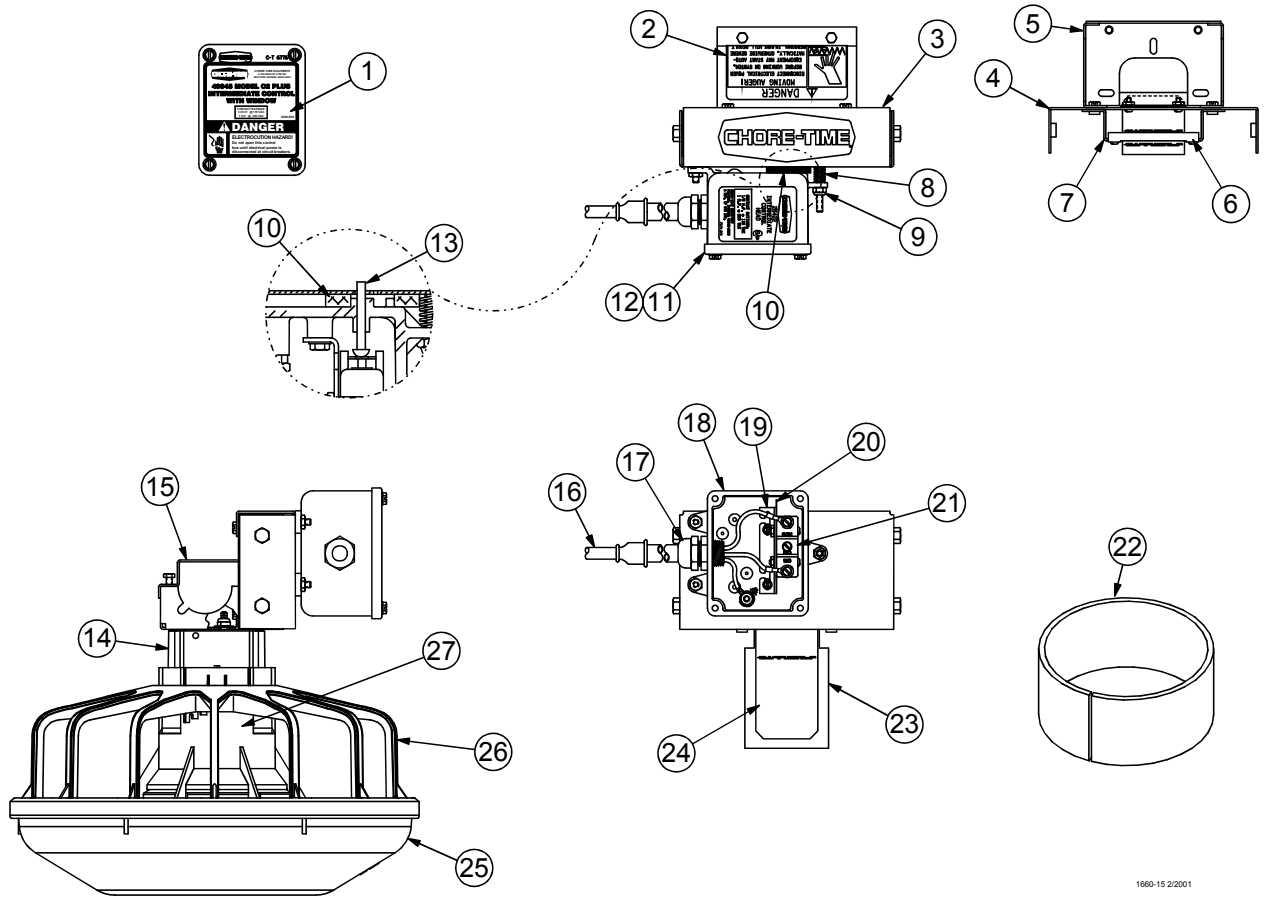

1660-15-2/2001

Item	Description	MODEL C2 PLUS Standard Part No. 40945	MODEL C2 PLUS Shallow Part No. 42013	MODEL G PLUS Standard Part No. 40946	MODEL G PLUS Shallow Part No. 42029
1	Danger/Product Identification Decal	2529-658	2529-248	2529-657	2529-694
2	Danger Decal	2527-9	2527-9	2527-9	2527-9
3	Back Cover	25047	25047	25047	25047
4	Front Panel	25046	25046	25046	25046
5	Tube Support	41364	41364	41364	41364
6	Paddle Retainer	25045	25045	25045	25045
7	Pivot Bracket	25048	25048	25048	25048
8	Spring	6972	6972	6972	6972
9	#10-32 Lock Nut	6963	6963	6963	6963
10	Gasket	6968-1	6968-1	6968-1	6968-1
11	Switch Box Cover	6776	6776	6776	6776
12	Gasket	6777	6777	6777	6777
13	Actuator Pin	8757	8757	8757	8757
14	Support Cone Assembly	40947	37371	40947	37371
15	Tube Retainer	14756	14756	14756	14756
16	Cord Assembly	4999-49	4999-49	4999-49	4999-49
17	1/2" Liquid Tight Connector	24685	24685	24685	24685
18	Machined Switch Box	34842	34842	34842	34842
19	Switch Bracket	46122	46122	46122	46122
20	Switch Insulation	1907-5	1907-5	1907-5	1907-5
21*	Actuator Switch	46091	46091	46091	46091
22	Cut Sleeve	43110	43110	43110	43110
23	Mylar Assembly	25318	25318	25318	25318
24	Switch Paddle	46123	46123	46123	46123
25	Feeder Pan	41501	41500	41501	41500
26	Feeder Grill	39567	39567	38599	38599
27	Adjustment Cone	38604	41504	38604	41504

*Actuator Switch, Chore-Time part number 7114, is no longer available. When replacing, use 7114 Switch Replacement Kit Part Number 46678.

Item	Description	C2 PLUS Standard Part No. 54563	C2 PLUS Shallow Part No. 54564	G PLUS Standard Part No. 54567	G PLUS Shallow Part No. 54568
1	Cut Sleeve	43110	43110	43110	43110
2	Bottom Cover	42085	42085	42085	42085
3	Top Cover with Insulators	42082	42082	42082	42082
4	Driver Block	4642	4642	4642	4642
5	Drive Tube Weldment	44794	44794	44794	44794
6	1/4-20x1-1/2 Socket Hd Screw	5083-8	5083-8	5083-8	5083-8
7	Tube Clamp	24063	24063	24063	24063
8	Support Bracket	42081	42081	42081	42081
9	Terminal Box Mounting Cover	6956	6956	6956	6956
10	Straight Liquid Tight Connector	26980	26980	26980	26980
11	Switch Box Gasket	6777	6777	6777	6777
12	Relay	28904	28904	28904	28904
13	Danger/Product Identification Decal	2529-710	2529-731	2529-709	2529-729
14	Cord Assembly	4999-116	4999-116	4999-116	4999-116
15	Liquid Tight Connector	24685	24685	24685	24685
16	Relay Plate	52316	52316	52316	52316
17	Grill	39567	39567	38599	38599
18	Adjustment Cone	38604	41504	38604	41504
19	Feeder Pan	41501	41500	41501	41500
20	#10 x 1/2 Hex Washer Head Screw	28075	28075	28075	28075
21	General Purpose Terminal Box	42627-3	42627-3	42627-3	42627-3
22	Liquid Tight Connector	23779	23779	23779	23779
23	Control Body Weldment	42080	42080	42080	42080
24	Support Cone	37077	44884	37077	44884
25	Pan Half Round Sensor	54670	54670	54670	54670
26	14" Flexible Conduit	26982-1	26982-1	26982-1	26982-1
27	Liquid Tight Connector	23810	23810	23810	23810
28	Anchor Plate	4188	4188	4188	4188

Electronic Sensor Mid Line Control

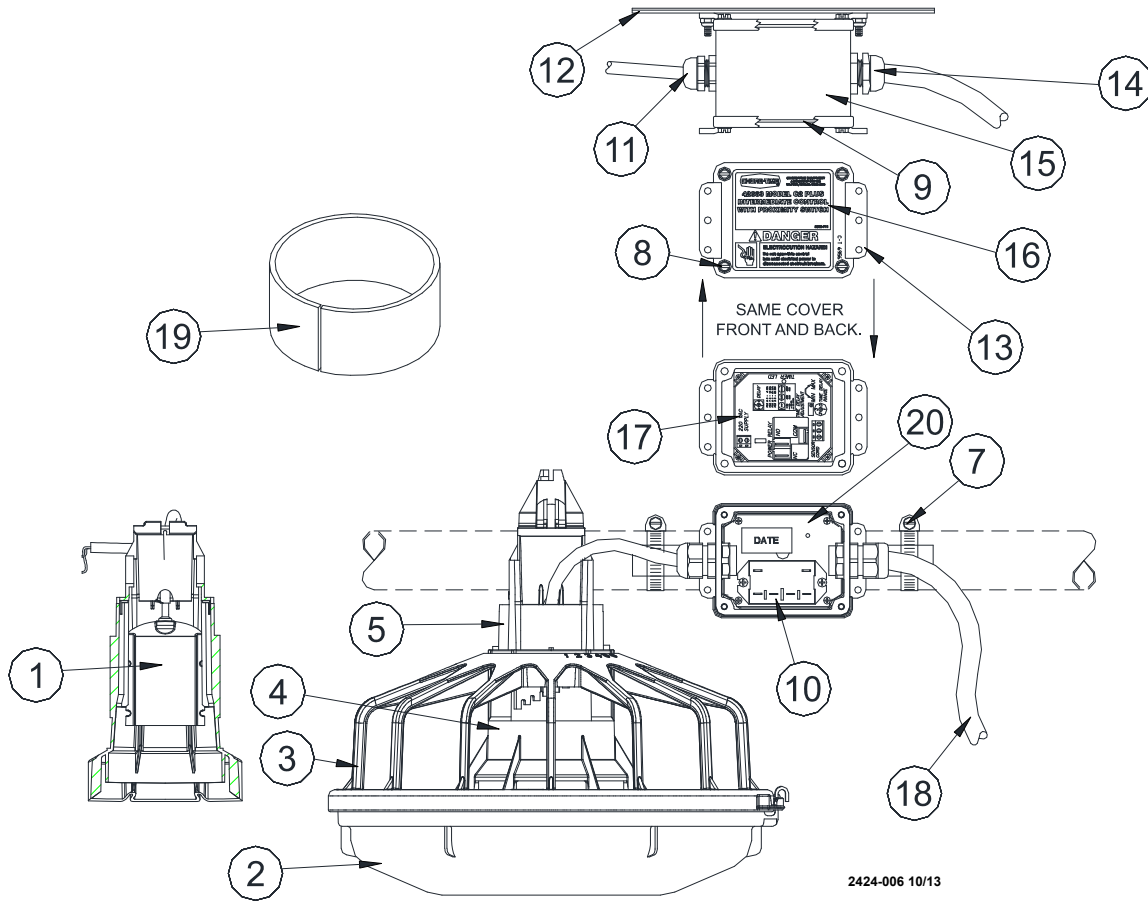

2424-006 10/13

Item	Description	Model C2 PLUS Standard with Electronic Sensor Part No. 54565	MODEL C2 PLUS Shallow with Electronic Sensor Part No. 54564	MODEL G PLUS Standard with Electronic Sensor Part No. 54569	Model G PLUS Shallow with Electronic Sensor Part No. 54570
1	Pan Half Round Sensor	54670	54670	54670	54670
2	Feeder Pan	41501	41500	41501	41500
3	Feeder Grill	39567	39567	38599	38599
4	Adjustment Cone	38604	41504	38604	41504
5	Support Cone	377077	44884	37077	44884
6	Slide Top Cap	38603	38603	38603	38603
7	Hose Clamp	3527	3527	3527	3527
8	#10 x 1/2 Hex Washer Head Screw	28075	28075	28075	28075
9	Switch Box Gasket	6777	6777	6777	6777
10	Relay	28904	28904	28904	28904
11	Liquid Tight Connector	23779	23779	23779	23779
12	Tube Mount	42681	42681	42681	42681
13	Terminal Box Mounting Cover	6956	6956	6956	6956
14	Liquid Tight Connector	24685	24685	24685	24685
15	General Purpose Terminal Box	42627-2	42627-2	42627-2	42627-2
16	Danger/Product Identification Decal	2529-711	2529-728	2529-712	2529-730
17	Pan Half Round Sensor	48200	48200	48200	48200
18	Cord Assembly	4999-117	4999-117	4999-117	4999-117
19	Cut Sleeve	43110	43110	43110	43110
20	Relay Plate	52316	52316	52316	52316

MODEL G PLUS Pan Extension (Optional)

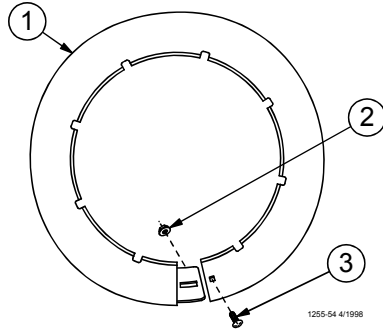

Item	Description	Part No.
1	Pan Extension	29510
2	Lock Nut	24208
3	1/4" Carriage Bolt	22692

2883 Power Winch

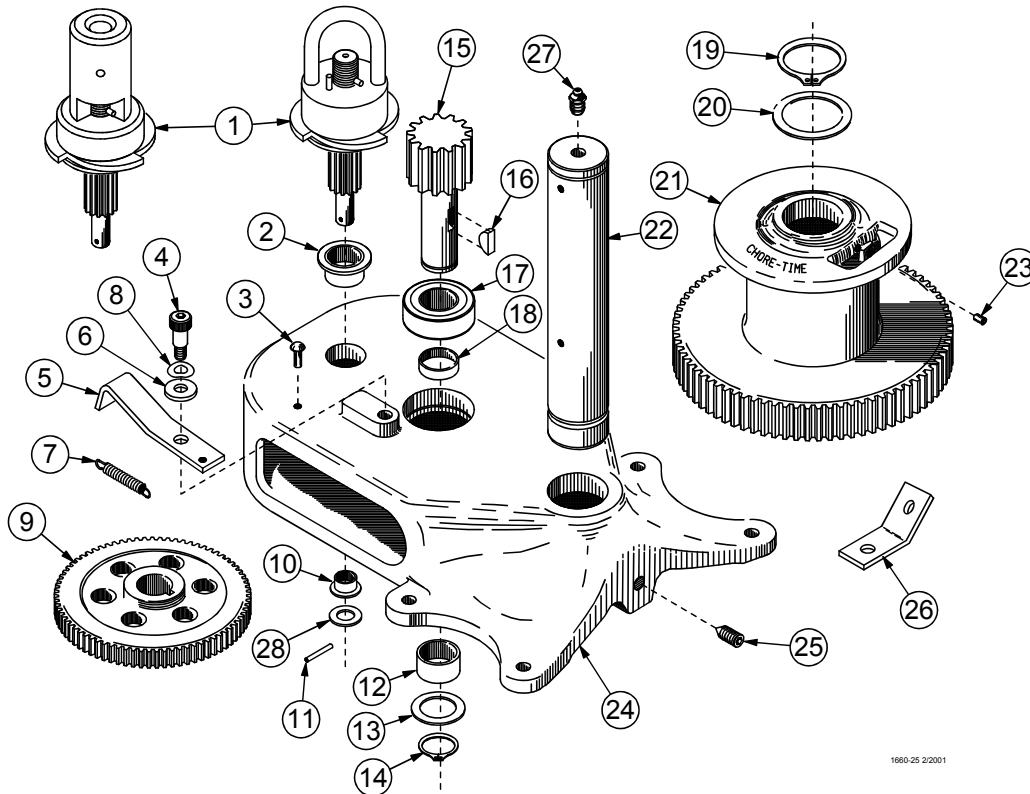

Item	Description	Part No.
1	Input Shaft Assembly Manual 42665 Electric 42666	
2	Flange Bushing	2967-2
3	Drive Stud	4128-1
4	Shoulder Bolt	4022-2
5	Pawl	6672
6	5/16" Flat Washer	2255-44
7	Spring	1543
8	Spring Washer	4023
9	Intermediate Gear	2890
10	Flange Bushing	3252
11	Spirol Pin	2960-3
12	Bushing	2967-4
13	Washer	2955-1
14	Retaining Ring	2958-1

Item	Description	Part No.
15	Drive Pinion	2962
16	Woodruff Key	2959
17	1" Bearing	4937
18	Spacer	4936
19	Retaining Ring	3556
20	Washer	2955-2
21	Winch Drum	3723
22	Drum Shaft	3637
23	Setscrew	603
24	Winch Frame	3719
25	Setscrew	3727
26	Cable Hook	2985
27	Grease Zerk	24499
28	Washer	2499

Miscellaneous Suspension Components

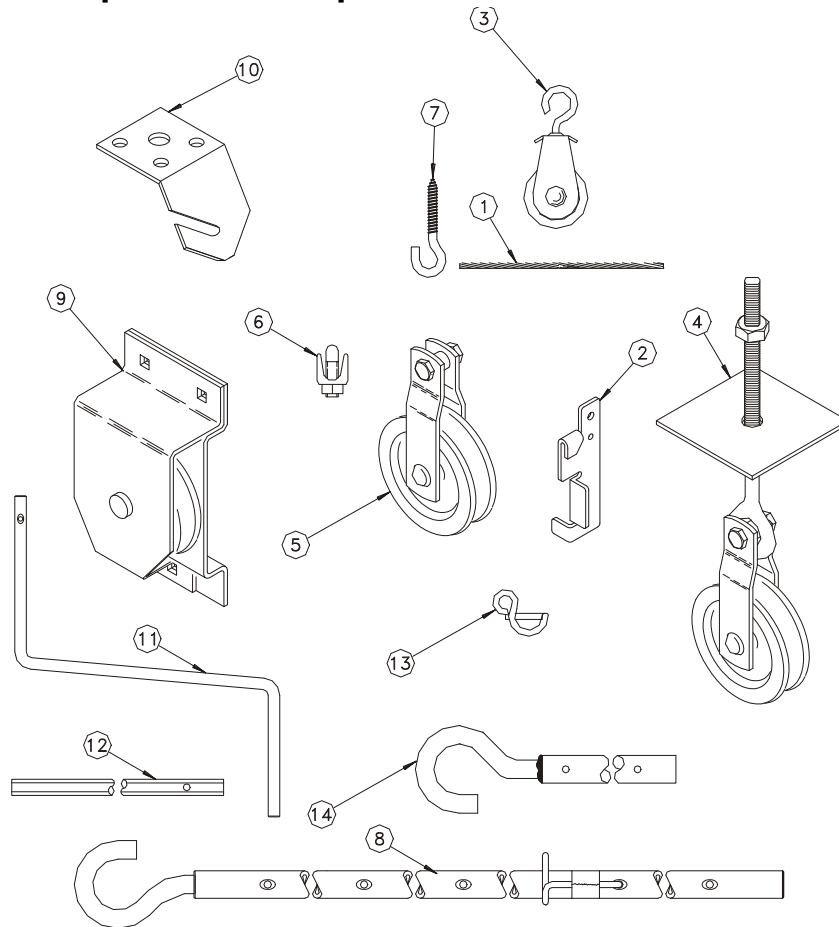

MF232-5R 9/96

Miscellaneous Suspension Components

<u>Item</u>	<u>Description</u>	<u>Part No.</u>
1	3/16 Cable	1213
2	Cable Lock	14337
3	Pulley with Swivel	3004
4	Heavy Duty Pulley Assembly	2014
5	Pulley	2500
6	3/16" Cable Clamp	732
7	ATF Screw Hook	2041
8	Extendable drive tube	47637
9	Pulley Assembly	28429
10	Ceiling Hook	28550
11	Handle Shank	3148
12	Drill Adapter Shaft	2886
13	Winch Handle Pin	3761
14	Winch Drive Tube (4')	2884-1
	Winch Drive Tube (8')	2884-2
	Winch Drive Tube (2')	2884-4
--	Full Line Suspension Kit	7948

Item 11 and Item 13 may be ordered as a kit under Part No. 2885.

Item 12 and Item 13 may be ordered as a kit under Part No. 2886

Item 11, 13 and 8 may be ordered as a kit under Part No. 47638.

Item 10 and Item 12 may be ordered as a kit under part no. 2885. Item 11 and Item 12 may be ordered as a kit under part no. 2886.

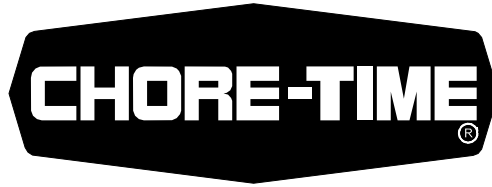

MADE TO WORK.

BUILT TO LAST.®

Revisions to this Manual

Page No.	Description of Change
	New Manual

Contact your nearby Chore-Time distributor or representative for additional parts and information.

Chore-Time Group
A division of CTB, Inc.
PO Box 2000
Milford, Indiana 46542-2000 USA
Phone (574) 658-4101 Fax (877) 730-8825
E-mail: www.choretimepoultry.com
Internet: poultry@choretime.com