

Poultry Production Systems

MODEL ATF™ and MODEL ATF™ PLUS

**Plastic Feed Cone Feeding System's
Installation and Operators Manual**



Installation and Operators Manual

Installation and Operators Manual

Chore-Time Warranty

Chore-Time Poultry Production Systems, a division of CTB, Inc., (“Chore-Time”), warrants each new CHORE-TIME® product manufactured by it to be free from defects in material or workmanship for one-year from and after the date of initial installation by or for the original purchaser. If such a defect is found by Chore-Time to exist within the one-year period, Chore-Time will, at its option, (a) repair or replace such product free of charge, F.O.B. the factory of manufacture, or (b) refund to the original purchaser the original purchase price, in lieu of such repair or replacement. Labor costs associated with the replacement or repair of the product are not covered by the Manufacturer.

Additional extended warranties for the equipment and/or systems listed below are provided to the original purchaser as follows (for all other CHORE-TIME® products purchased, the one-year warranty period shall apply):

1. TURBO® and RLX™ fans, less motors - 3 years
2. TURBO® fan fiberglass housings, polyethylene cones, and cast aluminum blades - for the life of the product
3. TURBO® fan motors and bearings - 2 years
4. TURBO® fan components (including plastic shutters) - 3 years
5. Poultry feeder pans that become unusable within five years from the date of installation - Warranty prorated after three years usage
6. Rotating centerless augers, excluding applications involving high moisture feed stuffs (exceeding 18%), for ten years from the date of installation. Note: MULTIFLO® and applications involving high moisture feed stuffs are subject to a one-year warranty
7. Chore-Time manufactured roll-formed steel auger tubes for ten years from the date of installation
8. ULTRAFLO® Breeder Feeding System auger and feed trough are warranted for a period of five years from the date of original installation against repeated breakage of the auger or wear-through of the feed trough caused solely by the auger
9. ULTRAPAN® Feeding System augers are warranted for a period of five years from the date of installation

CONDITIONS AND LIMITATIONS

1. The product must be installed by and operated in accordance with the instructions published by the Manufacturer or Warranty will be void.
2. Warranty is void if all components of the system are not original equipment supplied by the Manufacturer.
3. This product must be purchased from and installed by an authorized distributor or certified representative thereof or the Warranty will be void.
4. Malfunctions or failure resulting from misuse, abuse, negligence, alteration, accident, or lack of proper maintenance shall not be considered defects under the Warranty.
5. This Warranty applies only to systems for the care of poultry and livestock. Other applications in industry or commerce are not covered by this Warranty.

Chore-Time shall not be liable for any consequential or special damage which any purchaser may suffer or claim to suffer as a result of any defect in the product. "Consequential" or special damages" as used herein include, but are not limited to, lost or damaged products or goods, costs of transportation, lost sales, lost orders, lost income, increased overhead, labor and incidental costs and operational inefficiencies.

THIS WARRANTY CONSTITUTES THE MANUFACTURER'S ENTIRE AND SOLE WARRANTY AND THIS MANUFACTURER DISCLAIMS ANY AND ALL OTHER WARRANTIES, INCLUDING, BUT NOT LIMITED TO, EXPRESS AND IMPLIED WARRANTIES AS TO MERCHANTABILITY, FITNESS FOR PARTICULAR PURPOSES SOLD AND DESCRIPTION OR QUALITY OF THE PRODUCT FURNISHED HEREUNDER.

Chore-Time Distributors are not authorized to modify or extend the terms and conditions of this Warranty in any manner or to offer or grant any other warranties for Chore-Time products in addition to those terms expressly stated above.

An officer of CTB, Inc. must authorize any exceptions to this Warranty in writing. Chore-Time reserves the right to change models and specifications at any time without notice or obligation to improve previous models.

Effective: **July 2004**

Chore-Time Poultry Production Systems
A division of CTB, Inc.
410 N. Higbee Street • Milford, Indiana 46542 • U.S.A.
Phone (574) 658-4101 • Fax (877) 730-8825
E-mail: ctb@ctbinc.com • Internet: www.ctbinc.com

Thank You

The employees of Chore-Time would like to thank your for your recent Chore-Time purchase. If a problem should arise, your Chore-Time distributor can supply the necessary information to help you.

***Chore-Time Poultry Feeder Pan Pro Rata Schedule**

Year from date of installation during which pan becomes unusable	Charge to be paid by the purchaser for replacement.
0 - 1 years	NO CHARGE
1 - 2 years	NO CHARGE
2 - 3 years	NO CHARGE
3 - 4 years	4/10 of then current list price
4 - 5 years	5/10 of then current list price

Contents

Topic	Page
Chore-Time Warranty	2
CONDITIONS AND LIMITATIONS	3
About This Manual	6
Safety Information	6
Safety Instructions	7
Follow Safety Instructions	7
Decal Descriptions	7
DANGER: Moving Auger	7
DANGER: Electrical Hazard	7
CAUTION:	7
General	7
Support Information	7
MODEL ATF™ and MODEL ATF™ PLUS Recommendations & Guidelines	8
Manufacturer's Recommendations: Birds per Pan	9
Planning the Floor Feeding System	10
Suspension System	11
Screw Hook Installation	13
Ceiling Hook Installation	13
Power Winch Installation	15
Drop Installation	15
Hopper Assembly Procedure	16
Assembly	16
Suspend the Hopper	16
Feed Cone Assembly and Installation	17
MODEL ATF™ Pan Support Assembly	19
MODEL ATF™ Feeding System	19
MODEL ATF™ PLUS Pan Support Assembly	20
MODEL ATF™ PLUS Feeding System	20
Feeder Line Assembly and Suspension	21
Feeder Tube Assembly	21
Feeder Line Installation	21
Control Unit Installation	23
End Control Units	23
Mid-Line Control Units	24
Mid-Line Control Operation	25
Auger Installation	26
Auger Brazing	28
Winch Adjustable Feed Level Cones	29
Operation	29
Installation of the Winch Adjustable Feed Level System	29
Anti-Roost Installation	32
Wiring Diagrams	35
End & Mid-Line Control Wiring Diagrams: Single Phase(Ø)	35
Single Phase(Ø) Wiring Diagram	35

Single Phase(Ø) Wiring Diagram w/Motor Starter	35
End & Mid-Line Control Wiring Diagrams: Three Phase(Ø)	36
Three Phase(Ø) Wiring Diagram: 220/230 V.	36
Three Phase(Ø) Wiring Diagram: 380/415 V.	36
SENSOR PLUS™ Internal Wiring	37
SENSOR PLUS™ Control Wiring Diagram	37
Sensor Plus™ Three Phase(Ø) Wiring.	38
Mid-Line Control Internal Wiring	38
Maintaining the Feeding System	39
Floor Feeding System Maintenance	39
Gear Head Maintenance	39
Switch Adjustment procedure for the Control Units	40
SENSOR PLUS™ Sensor Switch Adjustment for Control Units	40
Feeder Line.	40
Power Lift Winch Maintenance	41
Trouble Shooting the Feeding System	42
Parts Listing	43
150# Hopper Components	43
Hopper Mount Bracket (Optional)	44
Single Boot Components Part No. 6821.	45
Twin Boot Components Part No. 8460	45
Feeder Line Components	46
Power Unit Components.	47
Power Unit Assembly Part Numbers	47
MODEL ATF™ End Control (SENSOR PLUS™): 50356.	48
MODEL ATF™ PLUS End Control (SENSOR PLUS™): 50357	48
MODEL ATF™ End Control (Mech. Switch): 50355.	49
MODEL ATF™ PLUS End Control (Mech. Switch): 50358	49
MODEL ATF™ Mid-Line Control (Mech. Switch): 50364	50
MODEL ATF™ PLUS Mid-Line Control (Mech. Switch): 50363	50
MODEL ATF™ Mid-Line Control (SENSOR PLUS™): 50366	51
MODEL ATF™ PLUS Mid-Line Control (SENSOR PLUS™): 50365	51
Feed Level Tube Winch Kit Part No. 46218	52
MODEL ATF™ Drop Tube Repair Tube Part No. 49160.	52
MODEL ATF™ PLUS Drop Tube Repair Tube Part No. 49163	52
2883 Power Winch	53
Miscellaneous Suspension Components.	54
MODEL ATF™ Pan Assemblies	55
MODEL ATF™ PLUS Pan Assemblies	56
Optional Parts	57

About This Manual

The intent of this manual is to help you in two ways. One is to follow step-by-step in the order of assembly of your product. The other way is for easy reference if you have questions in a particular area.

Important: Read **ALL** instructions carefully before starting construction.

Important: Pay particular attention to all **SAFETY** information.

- *Metric measurements are shown in millimeters and in brackets, unless otherwise specified. “ ” equals inches and “ ’ ” equals feet in English measurements.*

Examples:

1" [25.4]

4' [1 219]

- Optional equipment contains necessary instructions for assembly or operation.
- Very small numbers near an illustration (*i.e.*, 1257-48) are identification of the graphic, not a part number.

Note: The original, authoritative version of this manual is the English version produced by CTB, Inc. or any of its subsidiaries or divisions, (hereafter collectively referred to as "CTB"). Subsequent changes to any manual made by any third party have not been reviewed nor authenticated by CTB. Such changes may include, but are not limited to, translation into languages other than English, and additions to or deletions from the original content. CTB disclaims responsibility for any and all damages, injuries, warranty claims and/or any other claims associated with such changes, inasmuch as such changes result in content that is different from the authoritative CTB-published English version of the manual. For current product installation and operation information, please contact the customer service and/or technical service departments of the appropriate CTB subsidiary or division. Should you observe any questionable content in any manual, please notify CTB immediately in writing to: CTB Legal Department, P.O. Box 2000, Milford, IN 46542-2000 USA.

Safety Information

Caution, Warning and Danger Decals have been placed on the equipment to warn of potentially dangerous situations. Care should be taken to keep this information intact and easy to read at all times. Replace missing or damaged safety decals immediately.

Using the equipment for purposes other than specified in this manual may cause personal injury and/or damage to the equipment.

Safety–Alert Symbol



This is a safety–alert symbol. When you see this symbol on your equipment, be alert to the potential for personal injury. This equipment is designed to be installed and operated as safely as possible...however, hazards do exist.

Understanding Signal Words

Signal words are used in conjunction with the safety–alert symbol to identify the severity of the warning.



DANGER indicates an imminently hazardous situation which, if not avoided, **WILL** result in death or serious injury.



WARNING indicates a potentially hazardous situation which, if not avoided, **COULD** result in death or serious injury.



CAUTION indicates a hazardous situation which, if not avoided, **MAY** result in minor or moderate injury.

Safety Instructions

Follow Safety Instructions

Carefully read all safety messages in this manual and on your equipment safety signs. Follow recommended precautions and safe operating practices.

Keep safety signs in good condition. Replace missing or damaged safety signs.

Decal Descriptions

DANGER: Moving Auger

This decal is placed on the Panel Weldment.

Severe personal injury will result, if the electrical power is not disconnected, prior to servicing the equipment.

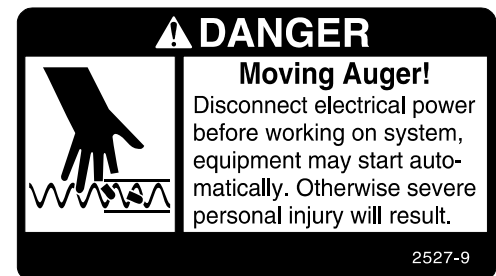

DANGER: Electrical Hazard

Disconnect electrical power before inspecting or servicing equipment unless maintenance instructions specifically state otherwise.

Ground all electrical equipment for safety.

All electrical wiring must be done by a qualified electrician in accordance with local and national electric codes.

Ground all non-current carrying metal parts to guard against electrical shock.

With the exception of motor overload protection, electrical disconnects and over current protection are not supplied with the equipment.

CAUTION:

Use caution when working with the Auger—springing Auger may cause personal injury.

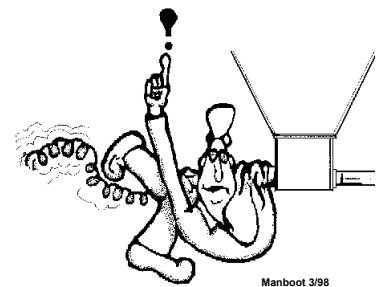
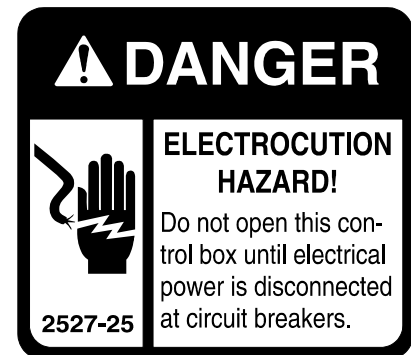

General

Support Information

The Chore-Time Adult Turkey Feeding System's have been designed to feed poultry. Using this equipment for any other purpose or in a way not within the operating recommendations specified in this manual will void the warranty and may cause personal injury.

This manual is designed to provide comprehensive planning and installation information. The Table of Contents provides a convenient overview of the information in this manual.

MODEL ATF™ and MODEL ATF™ PLUS Recommendations & Guidelines

The Chore-Time Adult Turkey Feeder is recommended for birds 5 to 6 weeks old and over. See “Manufacturer’s Recommendations: Birds per Pan” on page 9 for feeder space recommendations.

Adult Tom Turkeys: 40 to 50 birds per pan.

Hen Turkeys: 60 birds per pan.

Operate the equipment, if possible, before birds are housed to check installation, switch operation, and fill the feeder lines with feed.

The oil coating on new auger will cause the auger to deliver feed at a slower rate. To reduce the load on the motor while the equipment is being broken in, auger 50 pound (20 kg) increments of feed out to the pans. Allow the system to run for approximately 30 seconds, then add another 50 pounds (20 kg) of feed. Repeat this procedure until feed has been supplied to all the pans. Do not feed grit with the Adult Turkey Feeder.

Birds avoid dark or cold areas. Do not locate a control unit in such an area. Also, do not locate the control unit close to the end of the building. Allow a minimum of 10 feet (3 m) between the control unit and the building wall. If these problems are anticipated, they can be corrected during installation. Otherwise, artificial lighting can partially correct the problem.

During the break-in period, check the feed level in the pans. Normally, 1" to 1-1/2" (25 to 38 mm) of feed in the pan controls feed waste. When birds are housed, monitor the feed level in the pans and adjust as needed. Note: When birds are debeaked, a deeper feed level is required. Adjust the feed level by raising or lowering the feed level cone.

The height of the feeder line can be adjusted easily and it should be raised periodically as birds grow. Keep the lip of the pan approximately at the point where the bird’s neck joins the breast so that the birds must reach slightly. For the average 20 pound (9.1 kg) turkey, this will put the lip of the pan about 16 to 18 inches (405 to 455 mm) above the floor. Keeping the pans high results in less feed waste, less litter in pans, and easier bird movement.

Manufacturer’s Recommendations: Birds per Pan

Type	Max weight and/or weeks of age	Feeders	Number of birds/pan
Broiler	4.5 lbs/2 kg.	Revolution 12, Models C2 Plus, C2 Plus S, C, H2, H2 Plus	60 - 90
Broiler	6 lbs/2.7 kg	Revolution 8 & 12, C2 Plus, C2 Plus S, G Plus, G Plus S, C, H2, H2 Plus	55 - 80
Broiler	7 lbs/3.1 kg	Revolution 8 & 12, C2 Plus, C2 Plus S, G Plus, G Plus S, C, H2, H2 Plus	55 - 75
Broiler	9 lbs/4.0 kg	Revolution 8, G Plus, G Plus S	45 – 65
Broiler Breeder Pullet – rearing	0 – 18 weeks	C2 Plus (Breeder), C2 Plus S (Breeder)	14 - 15
Broiler Breeder Pullet – rearing	0 – 18 weeks Hi-Yield	C2 Plus (Breeder), C2 Plus S (Breeder)	12-14
Broiler Breeder Male – rearing	0 -- 18 weeks	C2 Plus (Breeder), C2 Plus S (Breeder), G Plus (Breeder), G Plus S (Breeder)	11-13
Broiler Breeder Layer	17 + weeks	C2 Plus (Breeder), C2 Plus S (Breeder)	13 - 14
Broiler Breeder Layer	17 + weeks Hi-Yield	C2 Plus (Breeder), C2 Plus S (Breeder)	12 - 13
Broiler Breeder Male	17 + weeks	Revolution 8, G Plus (Breeder), G Plus S (Breeder)	8-10
Commercial Layer Pullet – rearing	0 – 20 weeks	Revolution 12, C2Plus, H2, H2 Plus	40-60
Commercial Layer	18 + weeks	Revolution 12, C2 Plus, C, H2, H2 Plus	30 - 40
Turkey Poult	0 – 5 weeks	Revolution 8, H2 Plus, H2, G Plus, G Plus S	60 - 65
Turkey Poult	0 – 10 weeks	Revolution 8, G Plus, H2 Plus, H2	40 - 50
Turkey Female	5 + weeks	ATF, ATF Plus	60
Turkey Male	5 + weeks	ATF Plus	40 - 50
Ducks	0 – 3 weeks	G Plus, G Plus S	60 - 70
Ducks	4 – 8 weeks	G Plus, G Plus S	50 - 60

***Notice:** Please be advised that the maximum number of birds that may be successfully produced per feed pan may vary based upon such factors as climate, housing type or style, bird breeds, genetic factors of the birds at issue, grower management practices, etc. All other environmental and management circumstances, such as proper bird density per house, access to adequate nutrients in feed, access to adequate water supply, proper ventilation, adequate health care for the birds, and other similar factors, must meet industry standards and recommendations, if any, of applicable bird breeder companies.

*** NOTICE:** The above Manufacturer’s recommendations do not constitute a product warranty and are in no way to be considered as a guarantee of performance for poultry production. In addition, the above information in no way alters or revises the terms and conditions of any applicable Chore-Time manufacturer’s warranty.

Planning the Floor Feeding System

1. Select the House Layout.

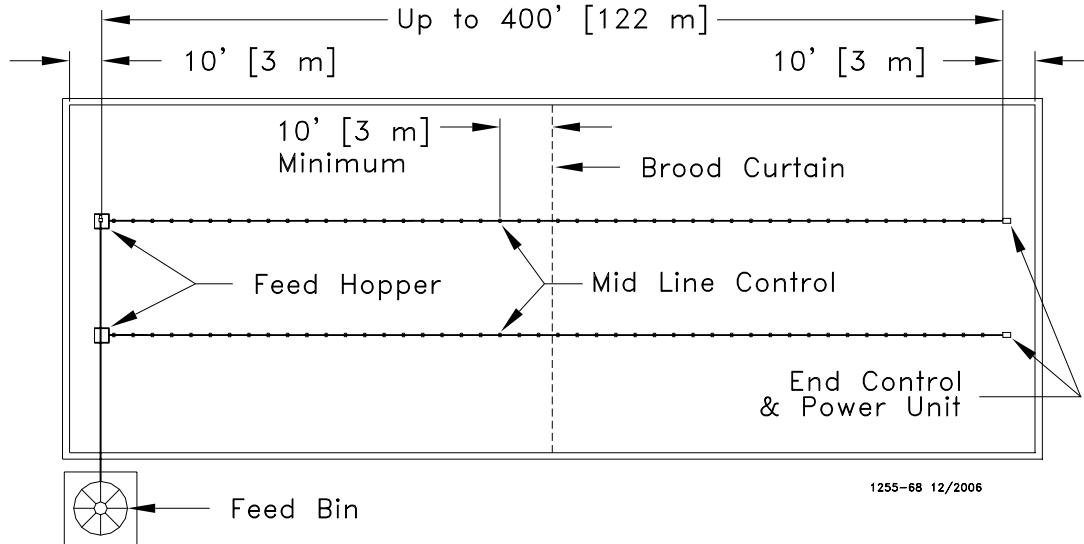

Figure 1. Component location diagram for systems up to 400 feet [122 m]. (Top View).

A. Systems with line lengths over 400' [122 m] should be split in the center, as shown in Figure 2. This will reduce auger running time and eliminate the need for mid-line controls for partial house brooding.

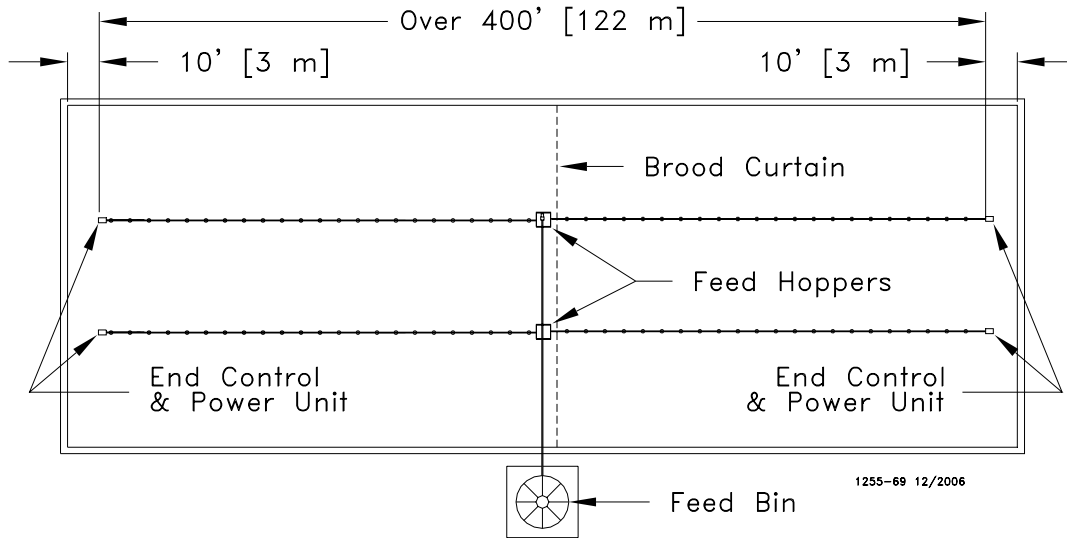

Figure 2. Component location diagram for systems over 400 feet [122 m]. (Top View).

2. Determine the feed bin location.
3. Determine the brood curtain location.
4. Determine the location for the end control pans. **The feeder control pans should be at least 10' [3 m] from the wall or brood curtain.**
5. Determine the distance to the feeder line from the side wall.
6. Determine the distance from the feed hoppers to the end wall for a straight line feeding system.

Suspension System

The feeder line suspension system is a vital part of your feeding system. Proper planning and installation is necessary to insure proper operation of the system. Use the chart below as a reference guide for determining support load requirements for your system.

Component	Weigh in pounds (kg)
Tube, Auger, Feeders, & Feed	9 lbs./ft (13.4 kg./m)
Power Unit & Control Unit Assembly	50 lbs. (22.6 kg)
150 lb. Feed Hopper & Feed	180 lbs. (81.6 kg)
Power Winch	40 lbs. (18.1 kg)

The type of installation required depends on feeder line length. **Figure 3** shows the suspension system for feeder line lengths to 350' (107 m). **Figure 4** shows the suspension system for feeder lines over 350' (107 m).

IMPORTANT: Notice that the feeder line MUST BE SUPPORTED WITHIN 3 FEET (1 M) OF THE MOTOR ON THE CONTROL UNIT. When Steel Hoppers with center suspension are installed the feeder line MUST BE SUPPORTED WITHIN 1 FOOT (300MM) OF THE HOPPER. If the Control Unit does not come out directly under a truss, fasten a pulley to a 2x8 (50x200 mm) board or other fixture that will span 2 trusses supporting the Control Unit. See “Hopper Assembly Procedure” on page 16 for special plastic hopper suspension.

After determining the type of suspension system required, decide where the feeder line is to be installed. Mark a straight line on the ceiling or rafters the full length of the feeder line. Use a string, chalk line, or the winch cable, temporarily attached with staples, to mark the line. Center the line directly over where the feeder is to be installed.

The recommended distance between the drops is 8' (2.4 m) on center. Do not exceed 10' (3 m) spacing on drop lines.

If the distance raised is greater than the distance between the drop spacings, offset the hooks 3" (75 mm) to each side of the line to prevent the cable clamps from catching the pulleys, see **figure 5**.

For installations using wood trusses, standard screw hook or the optional ceiling hook may be used to hold the pulley assemblies.

For installations using steel trusses, the ceiling hooks are available to hold the pulley assemblies.

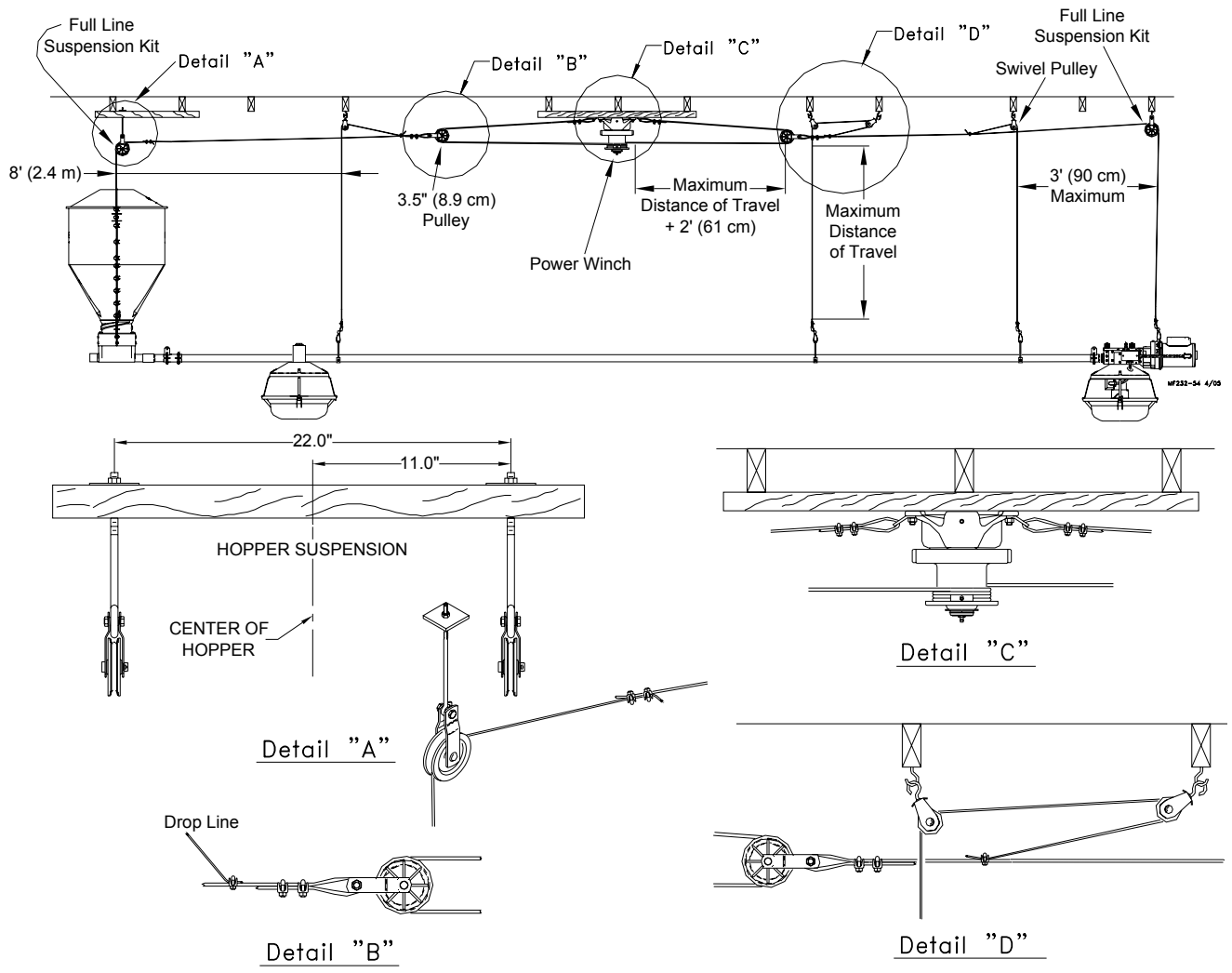

Figure 3. For Systems over 350' (107 m)

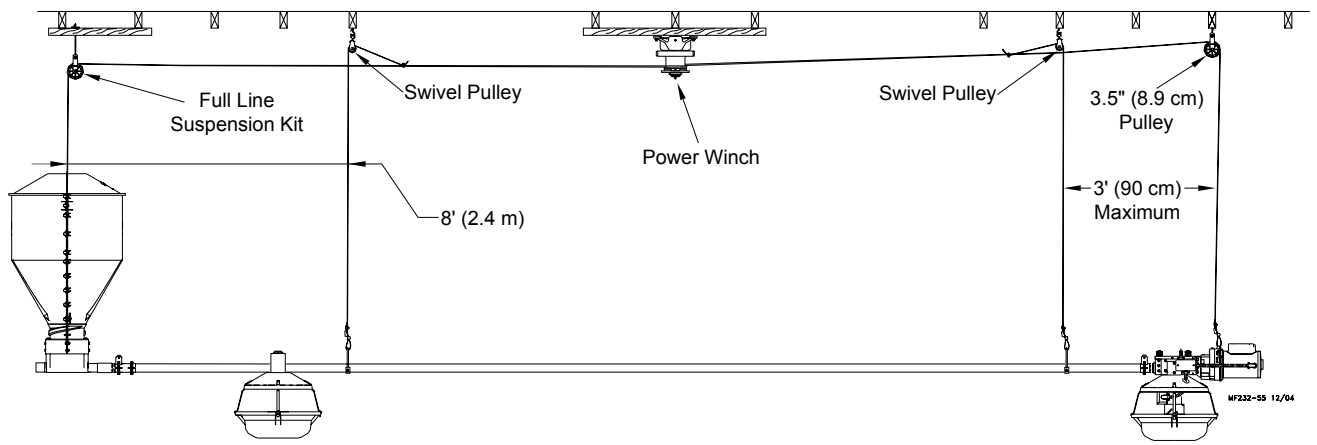

Figure 4. For Systems up to 350' (107 m)

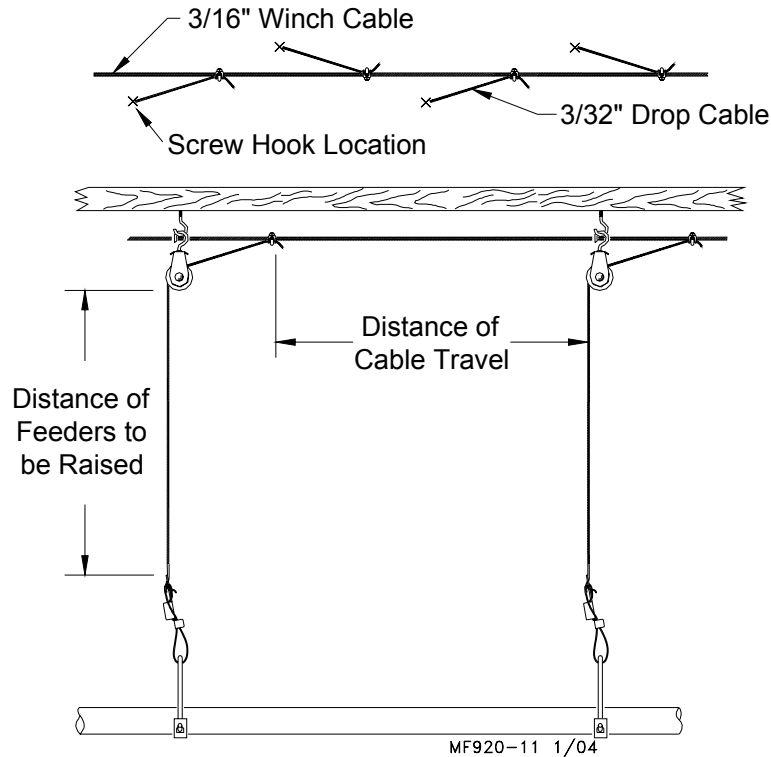

Figure 5. Suspension System with Offsets

Screw Hook Installation

Screw the hook into the truss the full length of the threads to prevent bending. The openings of the screw hooks must be pointed away from the direction of travel when the power winch raises the feeder line, see figure 6.

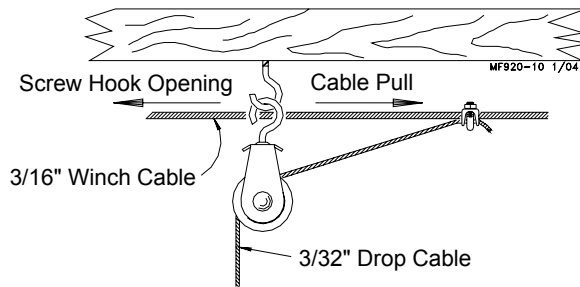

Figure 6. Screw Hook Installation

Ceiling Hook Installation

The ceiling hook may be used in a variety of installations. Depending on your individual situation, install the ceiling hooks as shown in Figures 7-10.

After securing the ceiling hook to the truss, slide the hook of a swivel pulley into the slot, as shown in Figure 11.

Steel Truss Installations

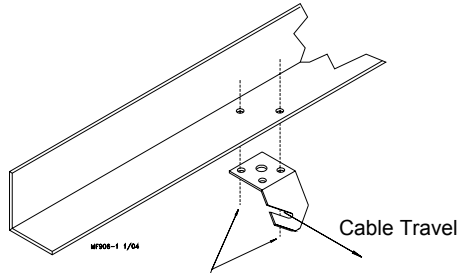

Secure ceiling hook to truss using self-drilling screws through opposite holes.

Figure 7. Wide Steel Truss Installations

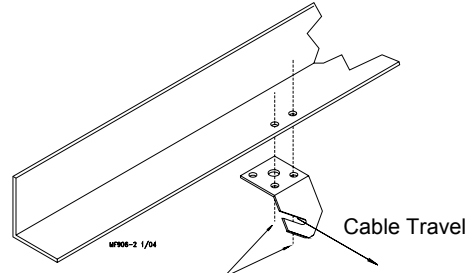

Secure ceiling hook to truss using self-drilling screws through side-by-side holes.

Figure 8. Narrow Steel Truss Installations

Steel Truss Welded Installations

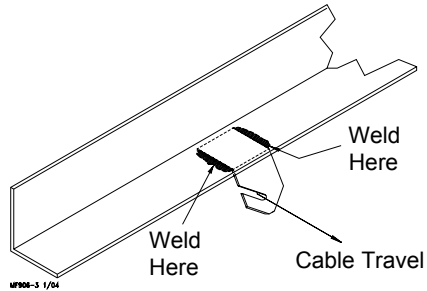
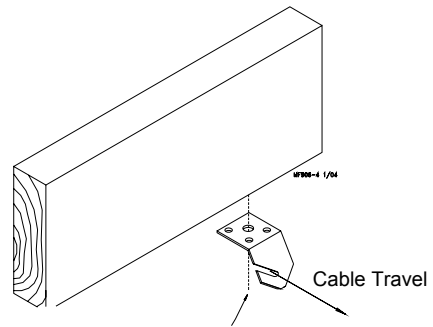

Figure 9. Welded Steel Truss Ceiling Bracket

Wood Truss Installations



Secure ceiling hook to truss using 1/4-20 lag bolt through large center hole.

Figure 10. Wood Truss Ceiling Bracket Installation

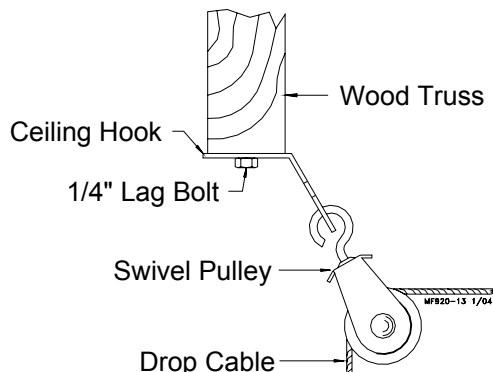

Figure 11. Swivel Pulley Installation

Power Winch Installation

1. Bolt the power winch, fully assembled, to a 2 x 8" (50 x 200 mm) board or other fixture that will span at least 3 rafters. The brake mechanism will protrude on one side.
For feeder lines over 350 feet (106 m), install a 2985 cable hook between the mounting bolt and power winch frame, as shown in **Figure 12**.
2. Attach the 2 x 8" (50 x 200 mm) board, with the power winch secured, to the ceiling at the center of the feeder line. The 2 x 8" (50 x 200 mm) or other fixture must be parallel to the line and must span at least 3 rafters or other fixture.
If the hopper is located at the center of the feeder line, locate the power winch a few feet offset from the center of the feeder line.
3. Extend the 3/16" (5 mm) cable the full length of the feeder line. Attach the cable temporarily to the ceiling with nails, staples, or some type of fastener.

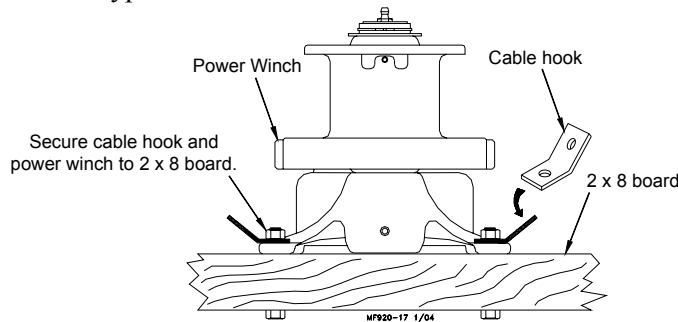

Figure 12. Power Winch Installation

4. Wrap the cable through the winch drum relief located near the bottom of the drum. Tighten the set screw to anchor the cable to the drum, **see figure 13**.
5. Turn the winch drum one full revolution. Guide the cable against the flange at the bottom of the winch drum. The cable must not wrap over itself on the drum, but should be wrapped as close as possible to each previous wrap, **see figure 13**.

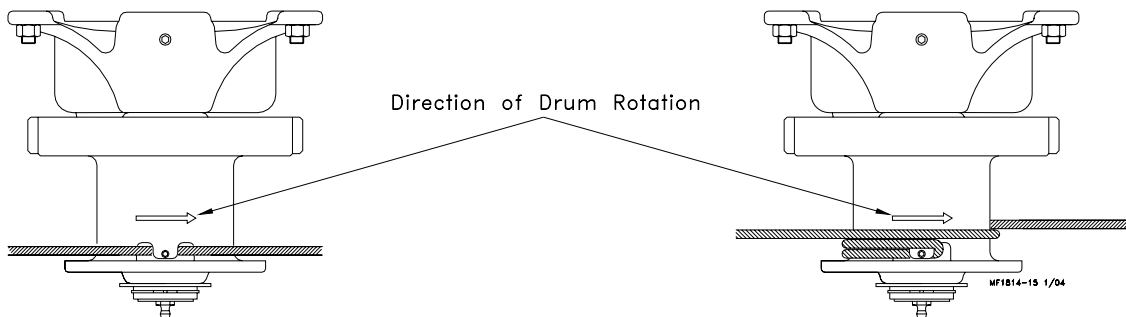

Figure 13. Cable Installation & Wrap

Drop Installation

1. Attach a 3004 Pulley to each hook.
2. Thread the end of the 3/32" cable through the pulley toward the winch. Clamp this end to the 3/16" winch cable about 6" (150 mm) from the pulley, using a 3/16" cable clamp, **see figure 6**.
3. Cut the cable long enough to allow for installation to the feeder line and to the adjustment leveler.
Sufficient cable is included to provide "throwbacks" on drops located beneath and near the winch. **See Figure 3 (on page 12)**, Detail D shows a "throwback" cable arrangement.
4. Begin installing suspension drops at the winch and proceed to the ends of the feeder line.
Keep the main cable tight between drops. It may be necessary to hang a weight on the end of the main cable to maintain tension.

Hopper Assembly Procedure

The 150 lb. Hopper Assembly is **NOT** designed for **single-point suspension**. The upper cross brace is designed for supporting the drop tube **ONLY**. This Hopper Assembly is to have **Two-point** suspension as stated.

Assembly

1. Assemble the 1/4-20 x 1-1/2" bolt to the brace with two 1/4-20 nuts. One nut should be assembled under the brace with the other on top. This bolt is to provide a place for the tube support assembly chain to be hooked, see **figure 14**.
2. Assemble the 150 lb. hopper halves and brace as shown in **Figure 14**, using #14 x 5/8" screws (supplied in hardware package).
3. Assemble the #8 x 1/2" screws and chain as shown in **Figure 14**.
4. Assemble suspension angles and suspension braces around feeder line boot (single or twin), using 1/4-20 x 1/2" Hex bolts and nuts (supplied in hardware package), see **figure 15**.

Note: The larger holes on the ends of the suspension angles need to be on the upper side of the assembly.

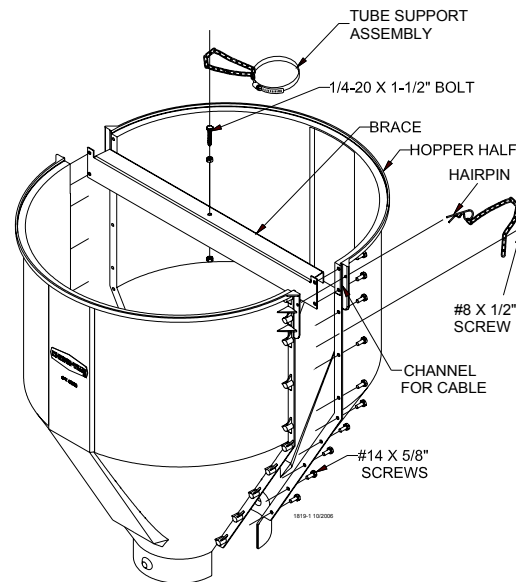

Figure 14.

5. Assemble the twist lock collar to the top of the feeder line boot (single or twin) using 1/4-20 x 1/2" bolts and lock nuts (supplied in hardware package), see **figure 15**.
6. Assemble the adjustment brackets to the suspension angles with 5/16-18 x 3/4" bolts and nuts (supplied in hardware package).
7. Two cable assemblies (cable with a sleeve clamp and a 5/32 thimble) are supplied with the suspension kit to support the hopper. Attach the cable assemblies to the adjustment brackets using the top holes of the adjustment brackets, see **figure 15**.

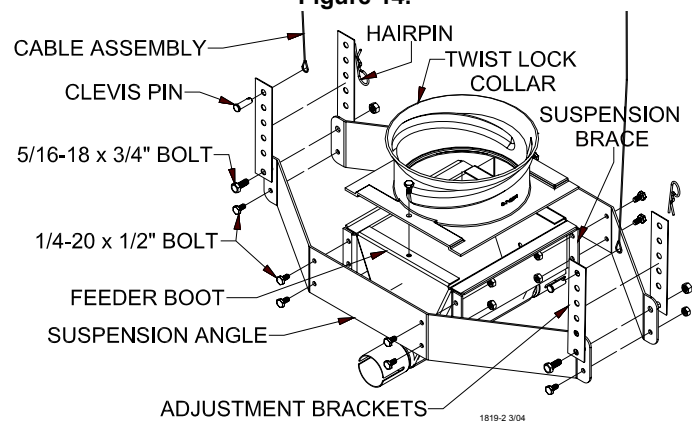

Figure 15.

8. Install two pulleys to either a 2" x 8" [50x200 mm] board that will span at least 3 rafters or a 3/8" [9.5 mm] thick steel plate welded to two pieces of angle iron that are long enough to span at least 2 rafters. Install the pulleys directly above the feeder line where the hopper is to be located. The pulleys should be spaced 22" [559mm] apart (11" [279 mm] from the center of the hopper in both directions), see **figure 16**.

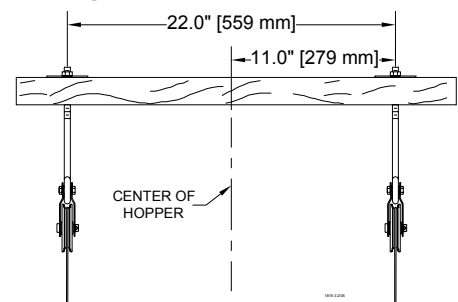
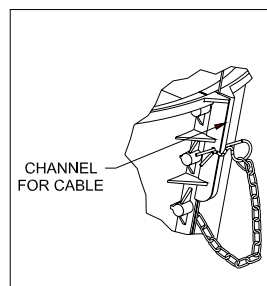

Figure 16.

Suspend the Hopper

1. Attach the boot to the feeder line.
2. Route the two cable assemblies up and around the pulleys.
3. Level the boot with the feed line and clamp the cables to the main cable using 1 cable clamp per cable assembly.
4. Place the hopper on top of the twist lock collar and rotate the hopper 90 degrees into position.

Make sure the cables lay in the channels on the sides of the hopper for support then use the hairpin to contain the cable.

Feed Cone Assembly and Installation

1. Assemble the feed level cone and adjustment cone as shown, see **figure 17**.

- To assemble the cones line up the threads on the feed level cone with the threads on the adjusting cone by inserting the adjusting cone into the feed level cone.
- Screw the (2) two parts together and adjust to feed level #3.

When assembling feed cones, DO NOT PUSH the parts together. Pushing the parts together could cause the threads to cross which will not allow the parts to lock in position.

When properly installed the cones WILL ONLY MOVE IF they are rotated to a different feed level.

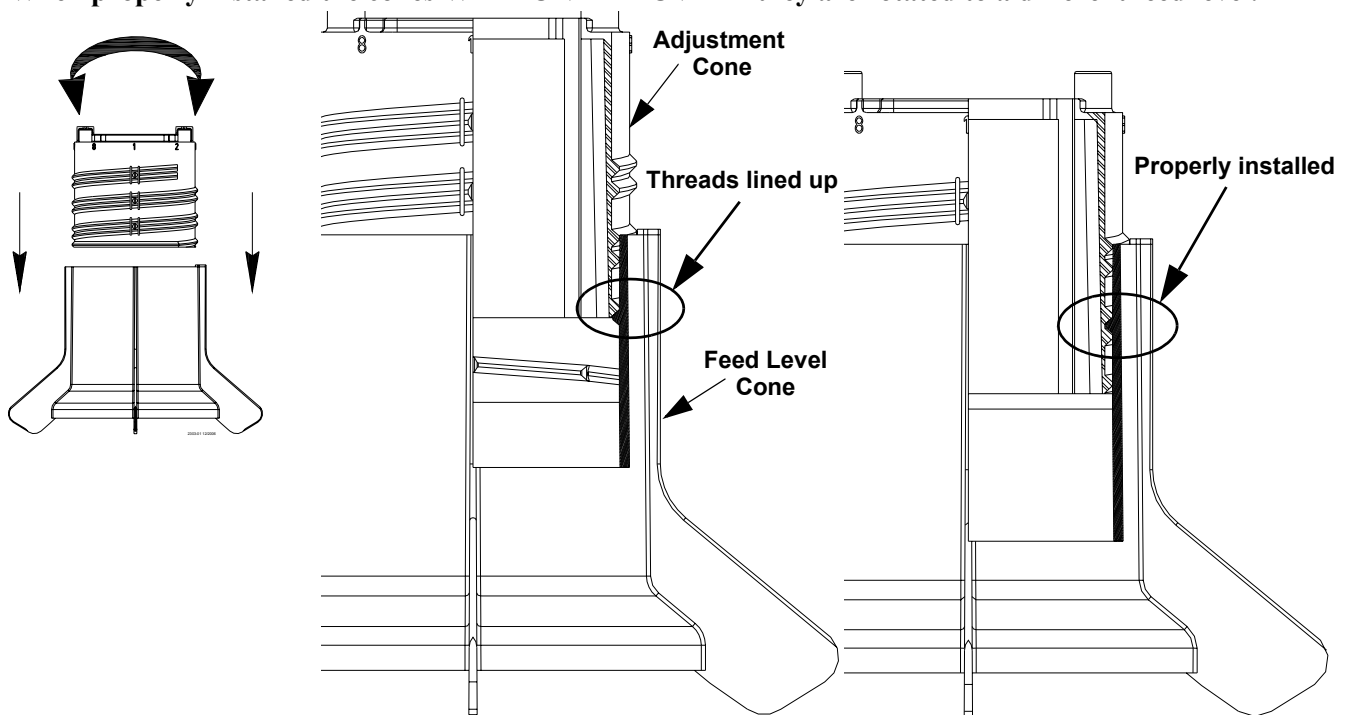
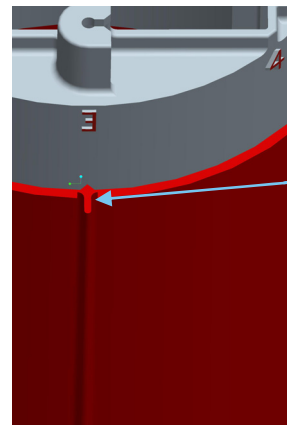

Figure 17. Cone Assembly

2. If the feed level cones are to be winch adjustable, install the cable assemblies at this point. If the feed level tubes are not to be winch-able - proceed to step 4.
3. Install two cables at each feed level tube as shown, see **figure 18**. The cable assembly should snap into the top of the feed level cone and needs to be pulled up tight against the inside.



Rotate the feed level cone until the arrow points to the #3 setting.

Note: After the feeder operates, re-adjustment of the feed level tubes may be done to achieve the desired feed level.

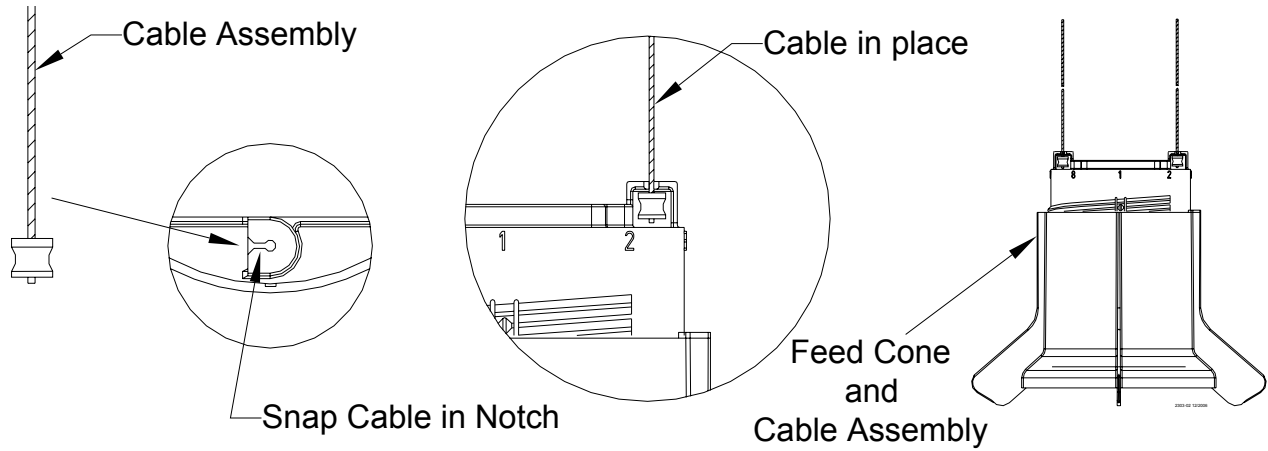
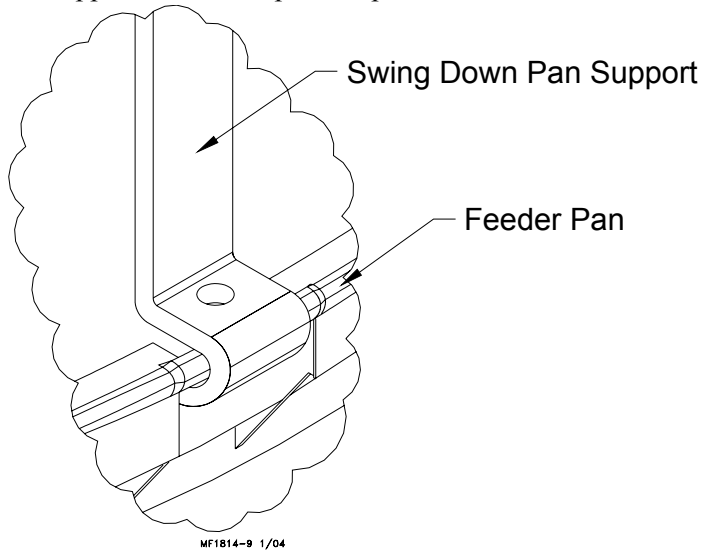

Figure 18. Cable Assembly Installation

4. Insert the drop tube into the feed cone assembly, see figure 19.
5. Insert the drop tube and cone through the shield opening. Install the pan shield supports in the slots of the drop tube. Route the cable through the openings in the shield.
6. With the bottom of the pan up, Hook the swing down pan support. Then rotate the pan down to hoop the remaining pan supports over the lip of the pan.



MF1814-9 1/04

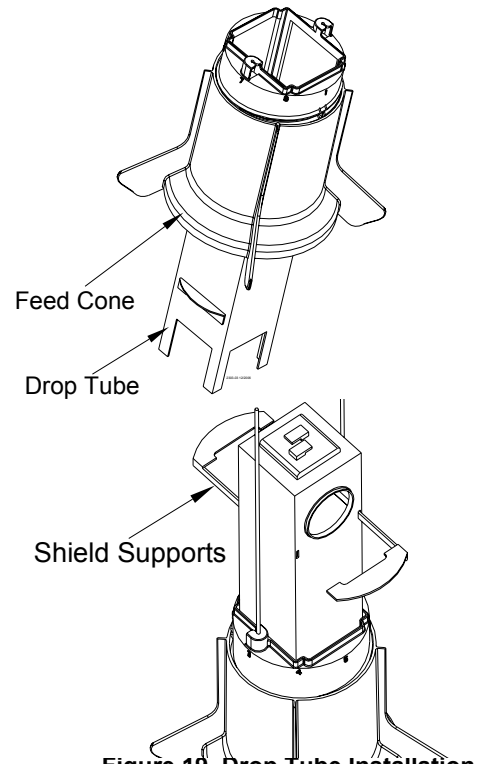

Figure 19. Drop Tube Installation

MODEL ATF™ Pan Support Assembly

MODEL ATF™ Feeding System

1. Attach one swing down pan support and three regular pan supports to the pan shield using rivets supplied. Always attach the swing down pan support at the same location on all pan shields. It will be necessary to support the pan shield while installing the rivets. Use a hammer to drive rivets as shown in **Figure 20**.

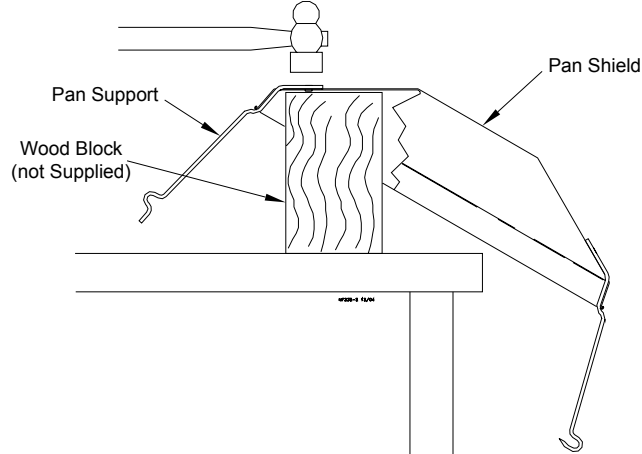

Figure 20. Pan Shield Assembly

2. Determine which feeder pan (Adult Turkey or Steel) is to be installed, see **figure 21**.

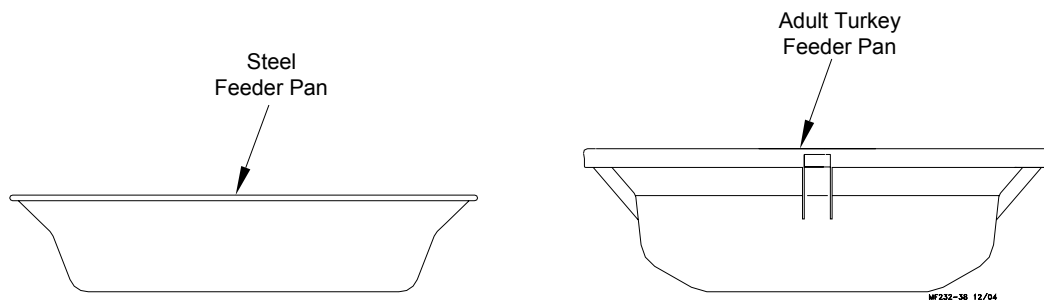

Figure 21. Feeder Pans

MODEL ATF™ PLUS Pan Support Assembly

MODEL ATF™ PLUS Feeding System

1. Attach (4) pan supports to the pan shield using the (4) carriage bolts and plastic lock nuts. Then tighten the nuts.

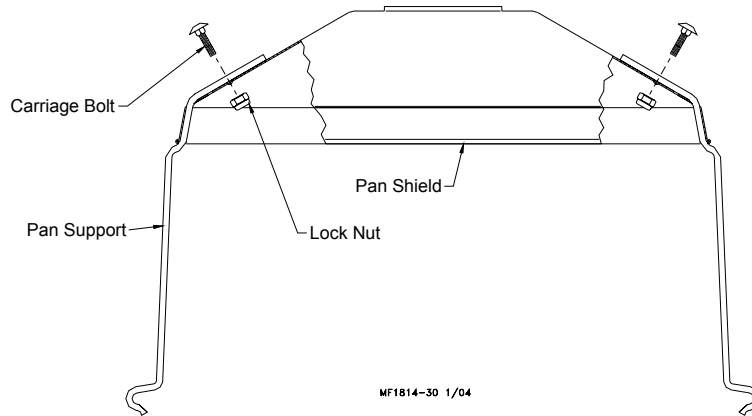

Figure 22. Pan Shield Assembly

2. Determine which feeder pan (Adult Turkey or Steel) is to be installed, see figure 23.

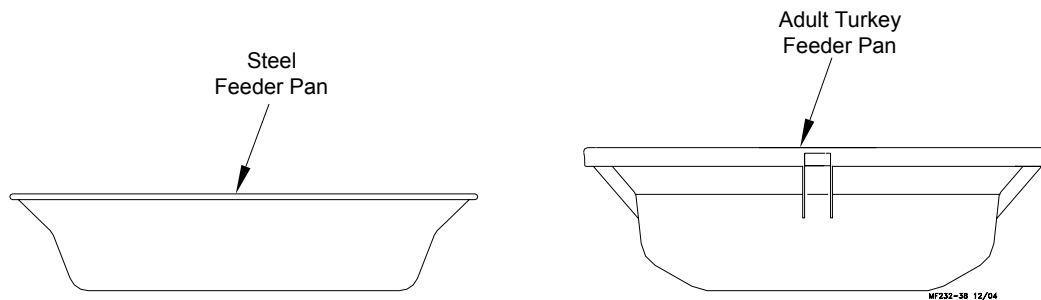

Figure 23. Feeder Pans

Feeder Line Assembly and Suspension

Feeder Tube Assembly

1. Slide one pan assembly onto the feeder tube for each outlet hole. Lift the drop tube through the pan shield so the feeder tube can slide through the holes in the sides of the drop tube. Install the pan assemblies so all the swing down supports are on the same side to the feeder line.
2. Rotate the feeder tube so the tab at the outlet hole will pass through the notch in the drop tube. Rotate the tube 180 degrees to lock the pans in place, **see figure 24**. Make sure outlet holes are down.
3. Position the tubes with pans attached end to end in the approximate location where they will be suspended. **The belled ends of the tubes must point towards the hopper.**

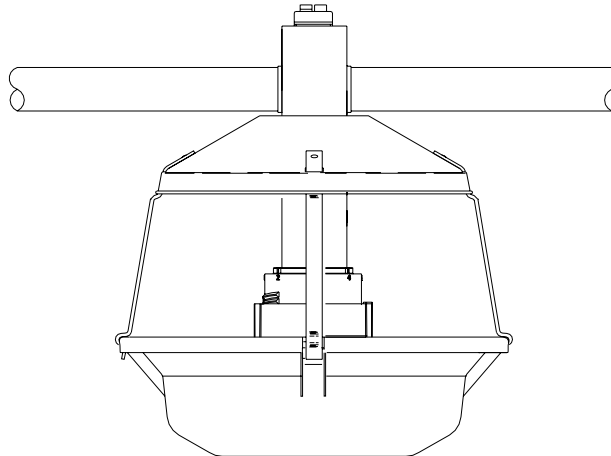

Figure 24. Install Feeders on Tubes

Feeder Line Installation

1. The tubes should be laying end to end in approximately the final location of the line. The expanded (belled) end of each tube should be toward the hopper end to the line, **see figure 25**.
2. Connect the individual feeder tubes together by inserting the straight end of the tube as far as possible into the belled end of the next tube.

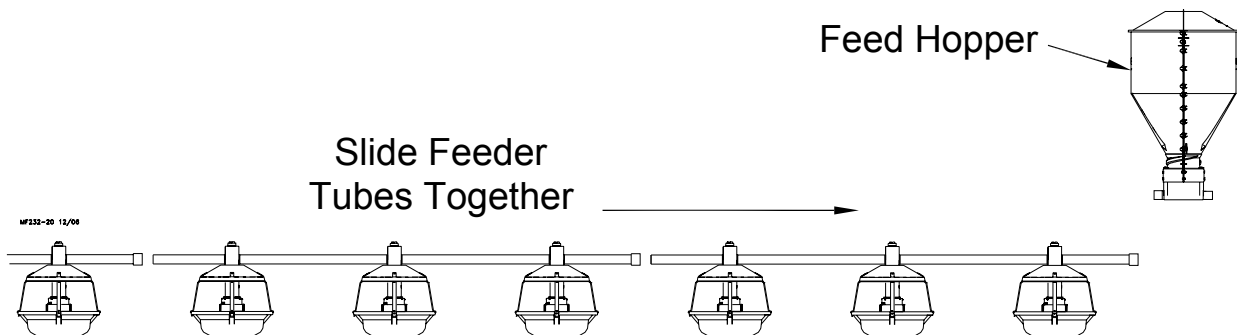

Figure 25. Feeder Line Assembly Procedure

3. Place a tube clamp assembly or clamp/anti-roost bracket at each joint. **Figure 26** shows the standard clamp and clamp/anti-roost bracket. Make sure each tube fits as far as possible into the belled end of the next tube. the outlet holes **must point down**. Install tube clamps as shown in **Figure 27**.
4. Begin at the hopper end of the line. Use a tube clamp with an anti-roost bracket to attach the hopper to the first tube. Use a tube clamp (w/o insulator) at the next joint between the first and second feeder tubes. Continue down the line clamping the tubes together. Use a tube clamp with anti-roost bracket at the end of the line. This should give a tube clamp with anti-roost bracket at each end of the line and at 20 foot (6 m) intervals along the length of the line.
5. If the optional mid-line control unit is used, install it at the desired location. **See “Mid-Line Control Units” on page 24.**

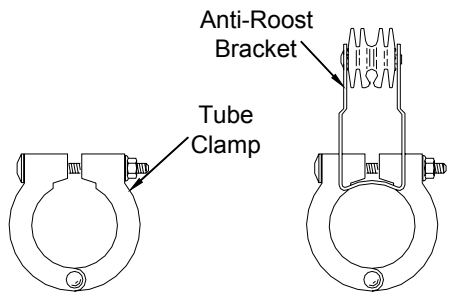

Figure 26. Tube Clamp and Anti-Roost Bracket

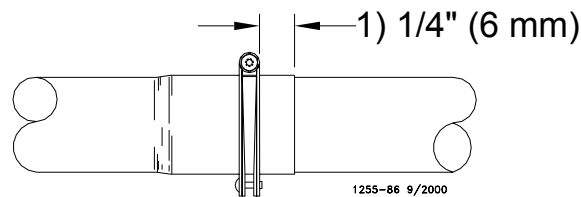

Figure 27. Tube Joint Connection

6. Install the hangers on the tubes on 8' (2.4 m) spacings determined by the suspension drop lines. **Figure 28** shows the proper installation of the hanger assembly. Make sure the outlet drop hole is down when the hangers are installed, otherwise feed will not be allowed to drop into the feeder pan.
7. Install the adjustment leveler within 6" (152 mm) of feeder line hanger. **Figure 28** shows the proper cable routing around the adjustment leveler.
8. Following installation of all drops, check drop cables before raising feeder line. Cable must be on all pulleys before raising the feeder line.
9. Raise the feeder line to a convenient working height.
10. After the feeder line has been suspended, level the system to the bird walking surface.
11. Before tightening each clamp;
 - make sure each tube is level (not sagging, sloping, etc.)
 - make sure the straight end to the tube is fully inserted in the belled end of the next tube.
 - make sure clamp is located, as shown in **Figure 27**.
12. Finally, tighten the tube clamps on the feeder tubes. Clamp the joints securely, **but do not crush the tubes**.

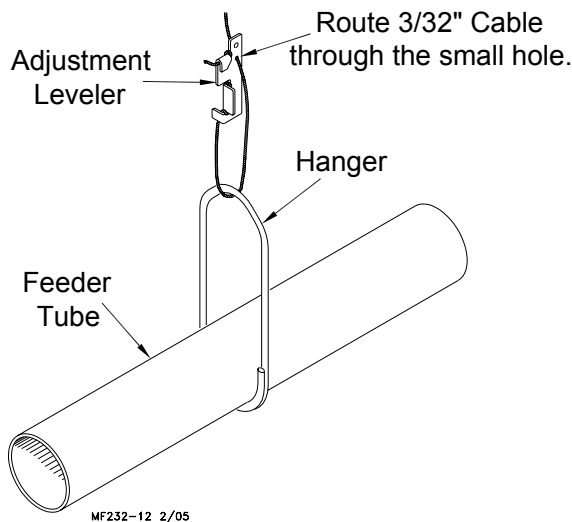

Figure 28. Adjustment Leveler and Hanger Installation.

Control Unit Installation

End Control Units

The assembly instructions are very similar for the ATF™ and ATF™ PLUS controls. The primary differences between the controls are in the electrical components and protection devices.

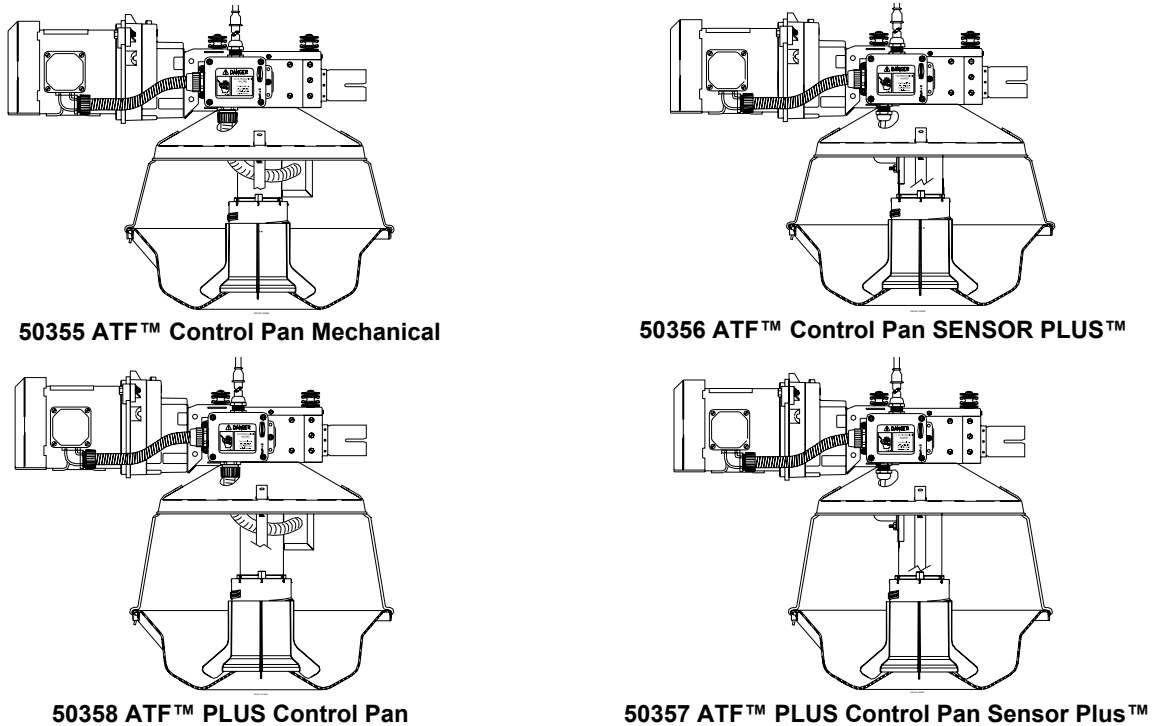

Figure 29. Control Units

1. Remove the four 5/16-18 x 5/8" bolts from the parts package and use them to bolt the anchor plate to the power unit. Install the anchor plate with the angled end pointing down, see **figure 30**.
2. Bolt the control unit body assembly to the power unit, using hardware supplied, see **figure 30**.

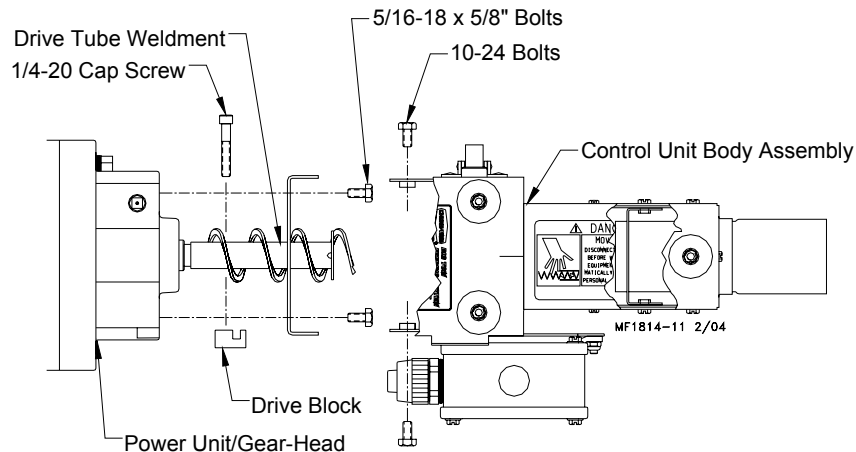

Figure 30. Control Unit Installation

3. Attach the pan supports to the control unit shield. See "MODEL ATF™ Pan Support Assembly" on page 19 or See "MODEL ATF™ PLUS Pan Support Assembly" on page 20.
4. The feed level switch is factory adjusted. To check adjustment before assembling depress the switch paddle and listen for the switch to "click". If the switch needs adjustment, See "Switch Adjustment procedure for the Control Units" on page 40.

5. Insert the drop tube and switch assembly through the pan shield from the bottom, see **figure 31**. The hole in the pan shield should be located on the same side of the drop tube as the switch cord and directly under the white box on the body assembly. Bolt the drop tube to the body assembly. The switch on the drop tube should be mounted opposite the power unit.
6. Single Phase: Install the 90 degree connector, flexible conduit, electrical wire, and conduit connector as shown in **Figure 32**.
Three Phase: Refer to applicable electrical standards for connecting power unit to control unit.
Components are not supplied by Chore-Time.

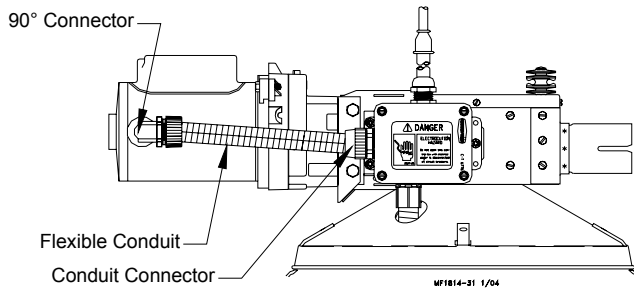

Figure 32. Conduit Installation

7. Insert the flex cable that is attached to the control switch through the hole in the control unit pan shield and attach the romex connector to the handy box, see **figure 33**.
8. **DISCONNECT ELECTRICAL POWER PRIOR TO WIRING THE CONTROL UNIT.**
Single phase control unit may be wired as shown, See **“Single Phase(Ø) Wiring Diagram” on page 35**
Three phase control unit must be wired as shown, See **“Three Phase(Ø) Wiring Diagram: 220/230 V.” on page 36**

Mount the control unit on the end of the feeder line and secure with a tube clamp. See **Figure 30 (on page 23)**. The distance between the control unit pan and the last pan should be 5' (1.5 m) or less.

Mid-Line Control Units

The mid-line control makes it possible to operate the feeding system when birds are confined away from the end control unit. Chore-Time recommends placing the mid-line control feeder at least 2 pans away from the curtain or partition, see **figure 34**.

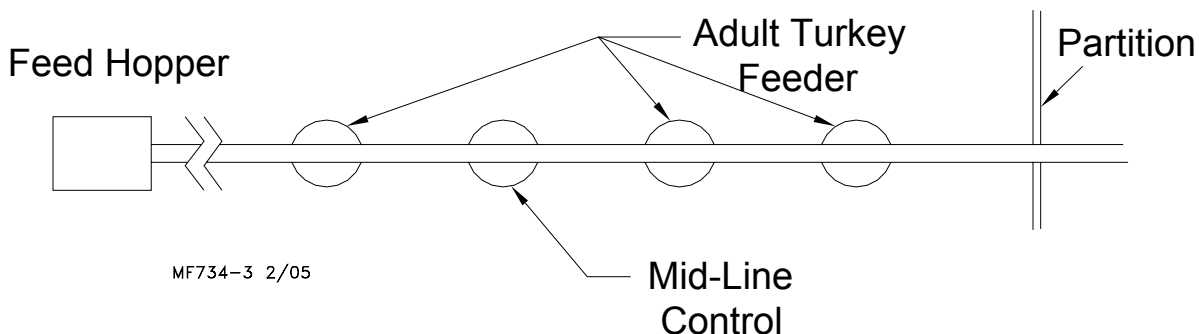

Figure 34. Mid-Line Control Installation

1. Determine which feeder tube and outlet hole will be used for the mid-line control. Slide a mid-line control

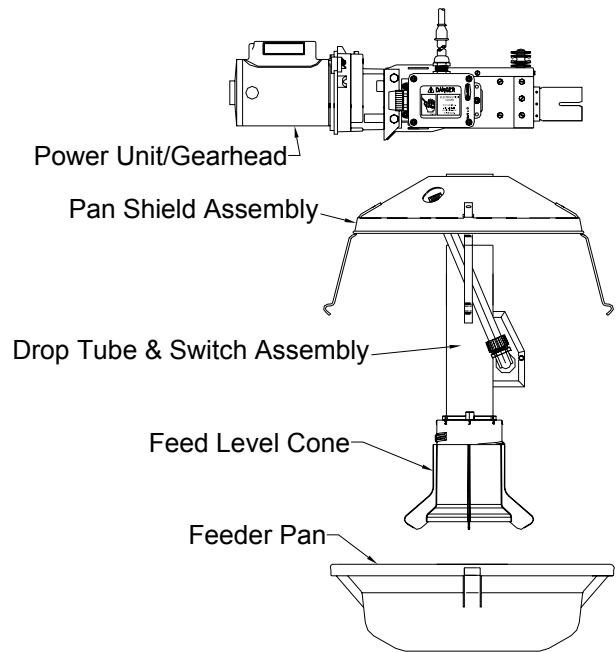

Figure 31. Drop Tube and Switch Assembly

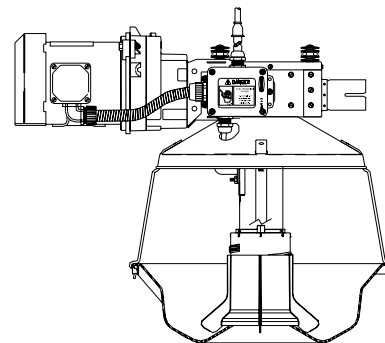

Figure 33. Switch Installation

into place on the tube.

Make sure the mid-line control is installed so the switch is directly under the incoming supply of feed, see **figure 35**.

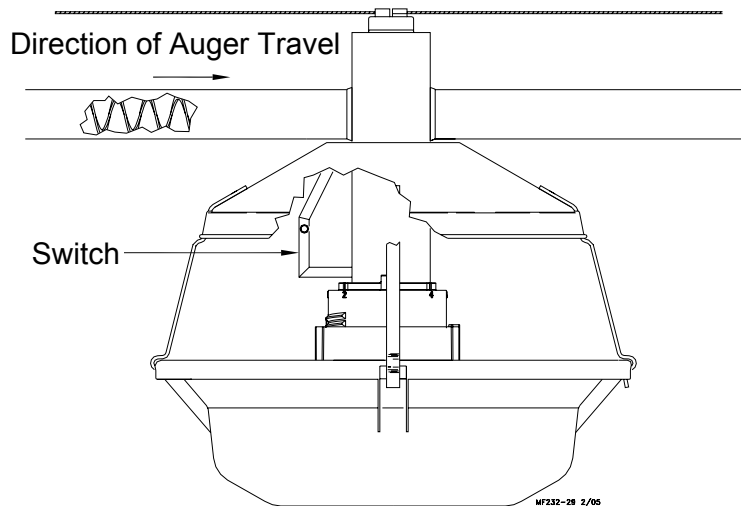

Figure 35. Orientation of the Mid-Line Control Switch

2. Install the feed adjustment cone and feed level cone similar to the standard feeders. The mid-line control serves as the drop tube assembly.
If the feeders are to have the winch able feed level cones, install the necessary cables now. See **“Winch Adjustable Feed Level Cones” on page 29**
3. Install the feeder pan, pan shield and other miscellaneous components similar to the standard feeders.
4. The feed level switch is factory adjusted. To check adjustment before assembling depress the switch paddle and listen for the switch to “click”. If the switch needs adjustment See **“Maintaining the Feeding System” on page 39**
5. Install a toggle switch out of the birds reach to disconnect power to the mid-line control. This allows the mid-line control to serve as a standard feeder when not used as a control feeder.
6. Wire the mid-line control as shown in the wiring diagram section of this manual. See **“Wiring Diagrams” on page 35**.

Mid-Line Control Operation

Chore-Time recommends having a toggle switch wired into the system to allow the feeder line to be changed from full house brooding to partial house brooding.

Maintain a lower feed level in the mid-line control than in the rest of the feeders. This will cause the mid-line control pan to operate more often, thereby starting the feeder line before the other pans become empty.

Do not hinder the bird movement around the mid-line control pan. Locate the curtain or partition several pans away from the mid-line control pan.

Provide adequate lighting so the birds will not shy away from the mid-line control area.

Auger Installation

Note: Use extreme caution when working with the auger. The auger is under tension and may spring causing personal injury. Wear protective clothing, gloves, and safety glasses when working with the auger.

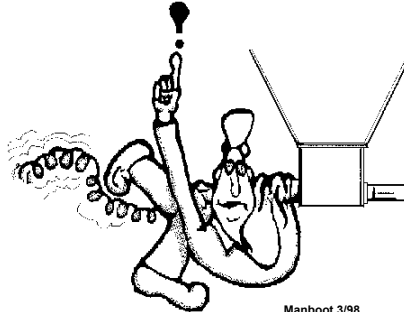

BE CAREFUL WHEN WORKING WITH THE AUGER!

Be careful not to drop the rolled auger when handling to avoid kinking the auger. Inspect the auger carefully as it is installed. Small kinks may be straightened but large kinks must be removed and the auger brazed back together.

Cut the leading 18" (450 mm) and last 18" (450 mm) off each roll of auger. Also, cut out any other distorted auger sections and reconnect the auger as specified in "Auger Brazing" on page 28.

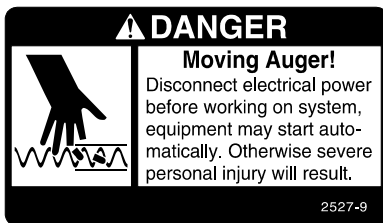

1. Remove the anchor & bearing assembly from the boot under the hopper.
2. Use extreme caution when pushing the auger into the auger tubes. Keep your hand away from the end of the auger tube to avoid injury.
 - With the auger coiled about 6' (1.8 m) from the end of the boot, feed the auger through the boot into the tubes.
 - Push the auger into the tube in short strokes.
 - Uncoil and handle the auger carefully to avoid damaging or kinking the auger.
3. If more than one coil is required for each feeder line the auger ends will have to be brazed together. Refer to "Auger Brazing" on page 28.
4. Continue installing auger until the auger reaches the control unit end of the feeder line.
5. Slide the drive tube and flat washer over the output shaft on the power unit, see figure 36.
6. Attach the auger to the output shaft of the power unit. Use the drive block to secure the auger to the output shaft.

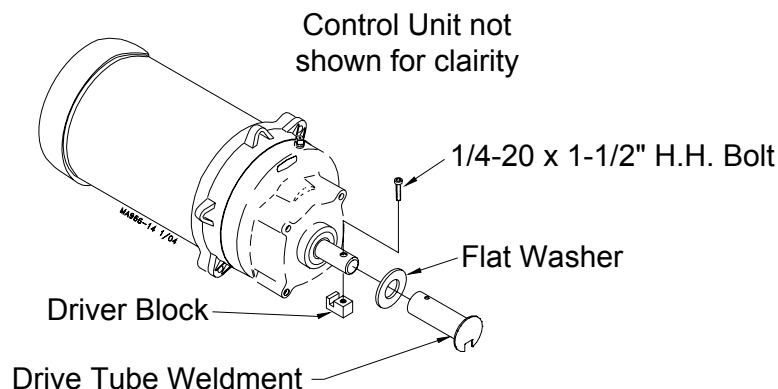

Figure 36. Auger Driver Components

7. Pull the auger at the boot end until it begins stretching then let it relax. In the relaxed position, mark the auger at the end of the boot. **See Figure 37.**

8. Auger stretch:

- The auger needs to be stretched 7" (180 mm) per 100' (30 m). Example: A 300' (90 m) feeder line requires 21" (500 mm) of stretch.
- Beginning at the relaxed position, measure the required amount of stretch. Mark the auger at that point.
- Grip the auger 8" (200 mm) ahead of this mark with locking pliers. Allow the auger to pull back into the boot so the pliers rest against the end of the boot,

1) Mark the *relaxed* auger at the end of the boot

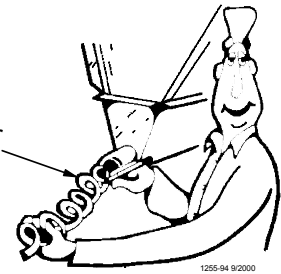

Figure 37. Marking the Relaxed Auger

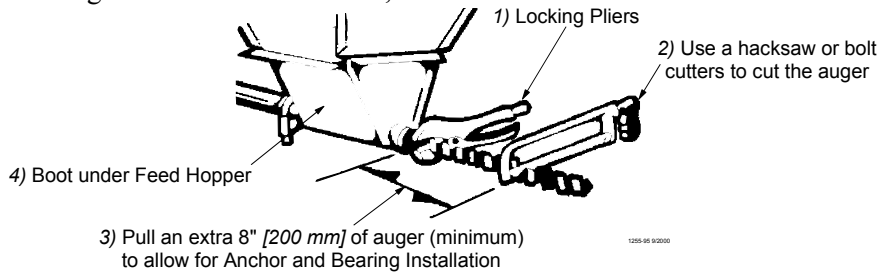

Figure 38. Cut the Auger with required stretch

9. Insert the anchor assembly into the auger, guide the tip of the auger between the two roll pins and continue to insert the auger until it touches the washer at the back of the anchor. Tighten the two screws in the center of the anchor.

10. **Carefully** remove the locking pliers while holding onto the anchor and bearing assembly and auger securely.

Slowly ease the auger back into the tube. **Use caution.**

If the auger is allowed to spring back, the bearing race may crack.

Install the bearing retainer and fasten with a tube clamp. Keep the bearing retainer flush with the end of the anchor for safety.

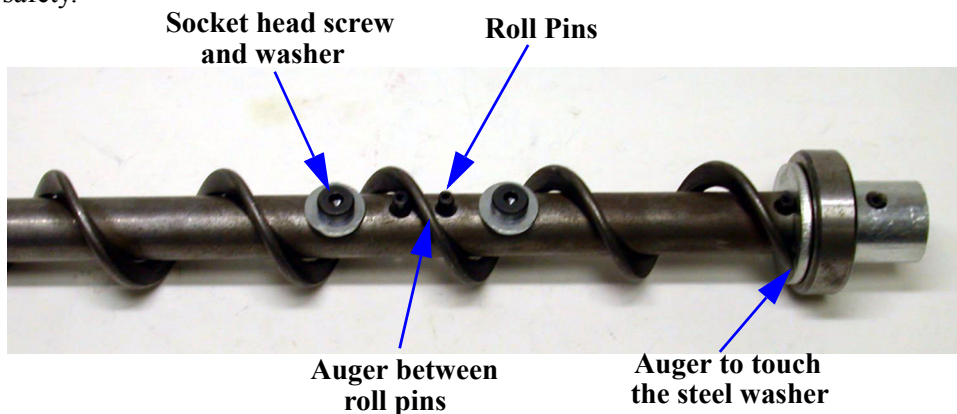

BE CAREFUL WHEN WORKING WITH THE AUGER!

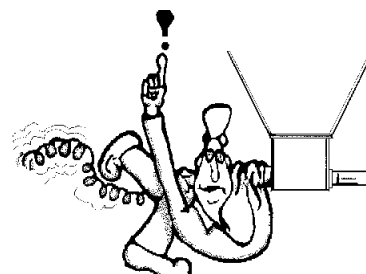

Auger Brazing

The auger should be brazed if it is necessary to splice or lengthen it. A bronze, flux coated rod is recommended.

The ends of the auger should butt against each other, **DO NOT THREAD INSIDE EACH OTHER.** See **Figure 39.** The joint should be well filled with no sharp edges or tough corners to ware against the tube. To align the auger for brazing, lay it in angle or channel iron and clamp it firmly in place. Use low heat. Allow the joint to air cool; rapid cooling will cause the auger to become brittle.

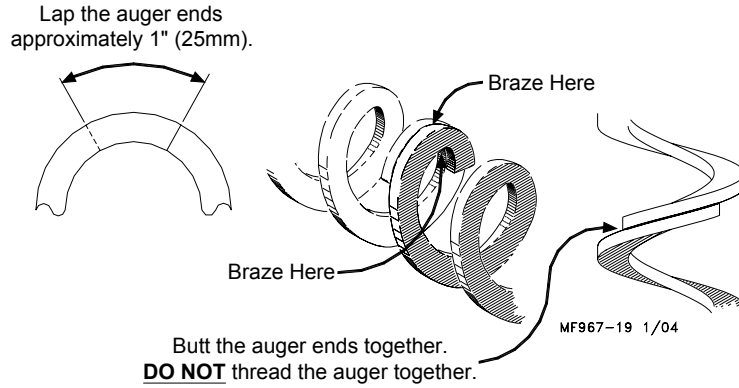

Figure 39. Auger Brazing

Winch Adjustable Feed Level Cones

Chore-Time's Adult Turkey Feeder can be equipped to provide winch adjustable feed level cones. New systems can be ordered with this feature. Existing systems can be (easily) upgraded to include feed level cone winching components.

The feed level cones are adjusted using a winch and cable. The maximum line length for each winch is 200' (61 m). The winch should be located in the middle of the line of feeders it is to adjust, see **figure 40**.

Operation

The feed level cones are winched up to flood the pans with feed to allow maximum access to the feed for young turkeys. As the birds grow the feed level cones can be lowered to reduce the feed level.

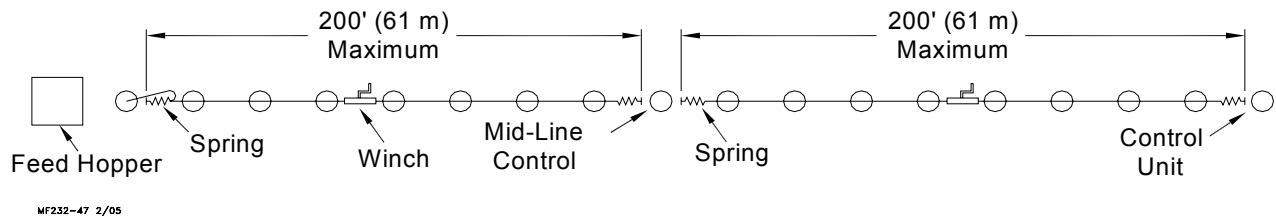

Figure 40. Installation of the Winch Adjustable Feed Level Tube System

Installation of the Winch Adjustable Feed Level System

1. Use two U-bolts provided to fasten the winch to the feeder line tube, see **figure 41**. The winch should be placed in the center of the line of feed level cones it will adjust, as shown in **Figure 40**. **THE LINE LENGTH MUST NOT EXCEED 200 FEET (61 M).**

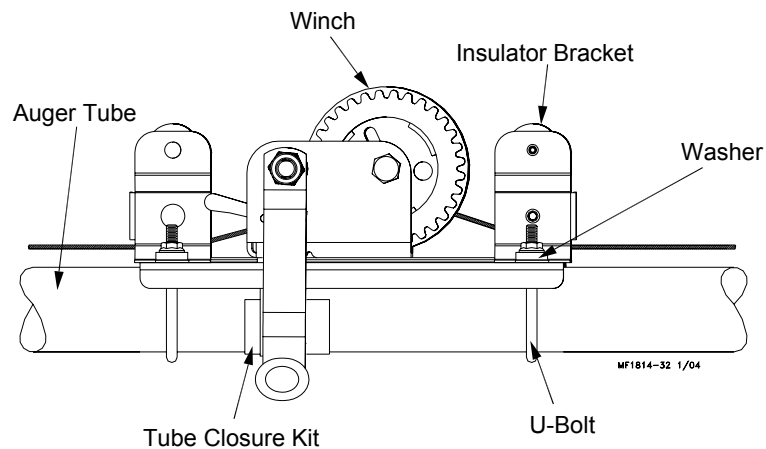

Figure 41. Winch Installation

2. Anchor spring to clamp on each side of the winch, see **figure 42**. Attach the tube clamp/spring assemblies to the feeder line tube at a maximum distance of 100 feet (30 m) from the winch, see **figure 40**.

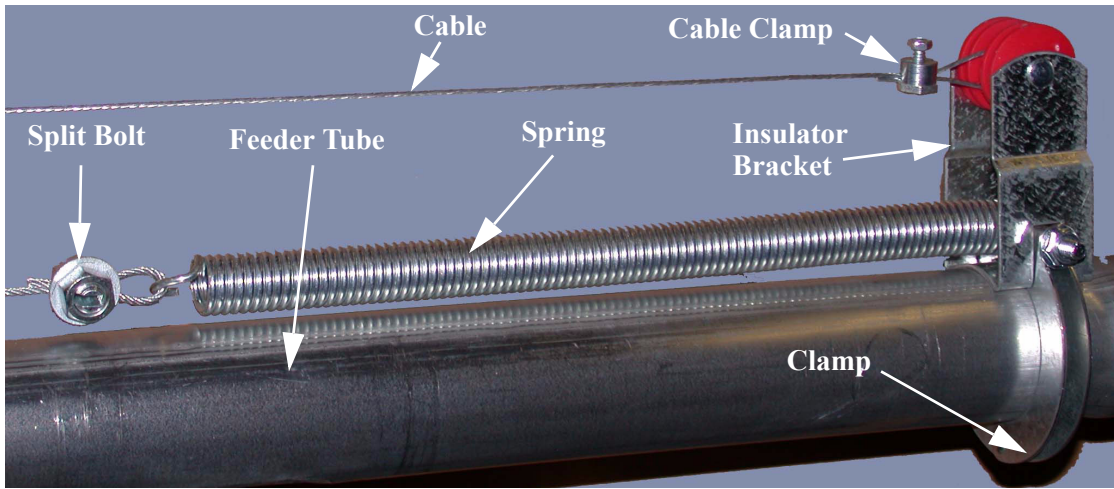

Figure 42. Spring and Insulator Bracket Installation

3. Lay the cable through the split in the winch drum. Turn the winch handle clockwise two revolutions to wind some cable onto the winch drum, see figure 43.

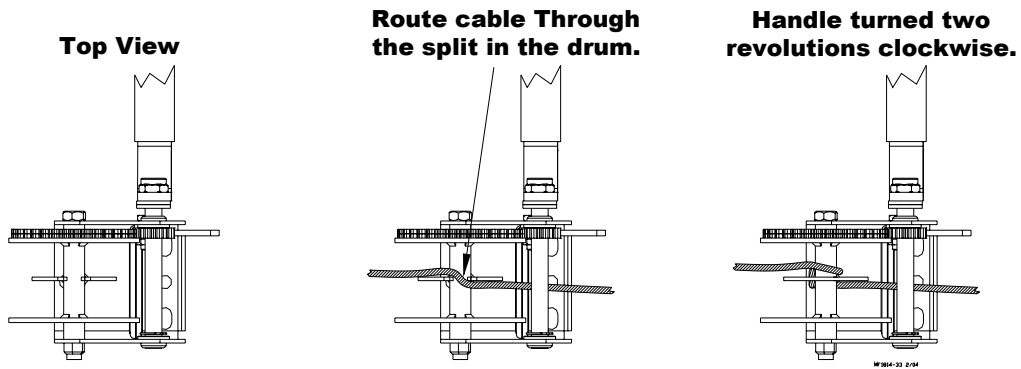

Figure 43. Winch cable wrap

4. Thread the cable through every drop tube to support the cable and keep it in position, see figure 44.

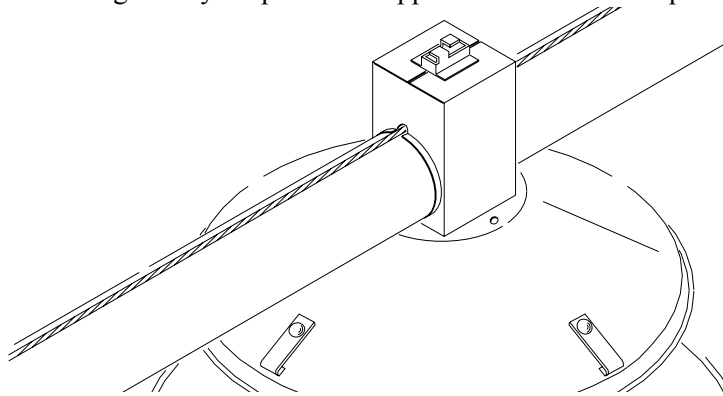

Figure 44. Winch Cable Routing

5. Loop the cable around the end of the spring and secure with a split bolt cable clamp, see figure 42.

6. There is not enough room between the feed hopper and the first feeder pan to attach and stretch the spring. Install the spring in between the first and second pan after the hopper. Then route the cable back to the first pan and attach to the feed tube cable assemblies, see figure 45.

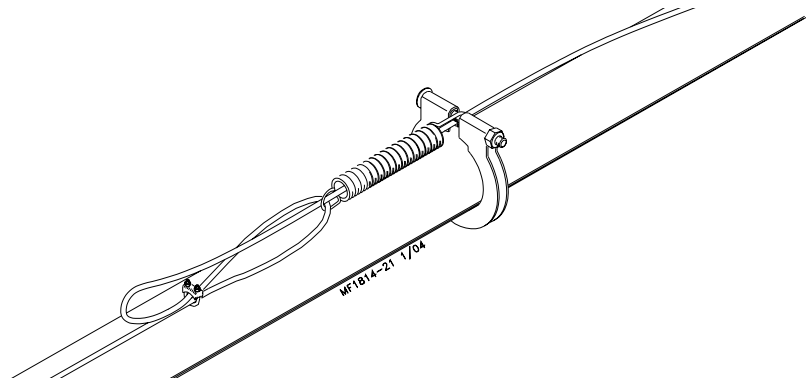

Figure 45. Hopper End Spring Installation

7. Install two cable assemblies at each feed level cone (if the cable assemblies have not yet been installed). The cable stop should be on the inside of the feed level cone and pulled up tight against the inside, **See Figure 18 (on page 18)**.
8. Thread the cable assemblies through the holes on each side of the pan shield from the underside. Then clamp to the master cable with a cable clamp, **see figure 46**.

Note: Before clamping the cable assemblies to the cable, make sure:

- A. The springs at each end of the cable are stretched approximately 14" (355.6 mm).**
- B. The feed level cones are raised as high as possible.**
- C. The stop on the cable assemblies are pulled up against the inside of the feed level cone.**

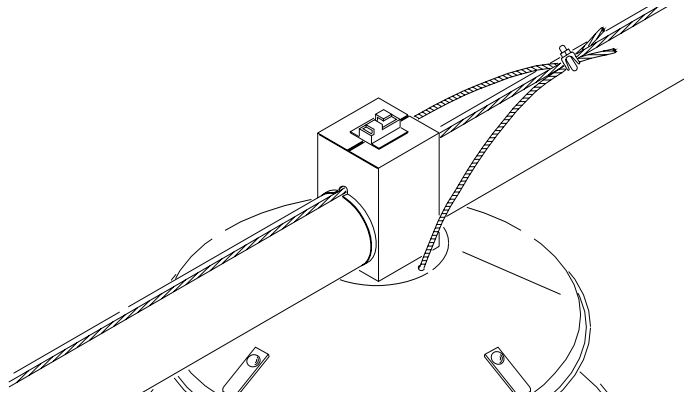

Figure 46. Cable Assembly Installation

Anti-Roost Installation

1. Unroll the bulk anti-roost cable.

Note: If the cable is unrolled as shown in Figure 47, taking 5 loops of the coil with one hand and then changing hands to remove 5 loops as it is unrolled the cable will lie flat during installation.

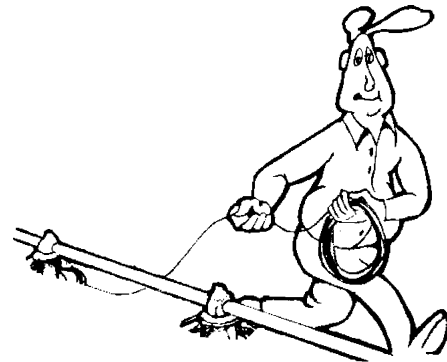

Figure 47. Unrolling the Cable

2. Start at the hopper end of the line and form a loop around the anti-roost bracket. For best results, make a double loop around the anti-roost insulator in the center groove of the insulator and fasten with a 3/32" cable clamp as shown in Figure 48.
3. Insert the cable in the insulator on the top of each grill support between the hopper and the next anti-roost bracket.

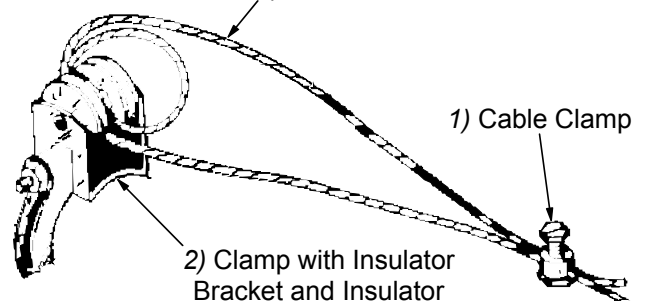

Figure 48. Anti-Roost Cable at the Hopper

4. Attach a spring in the center groove at the second anti-roost bracket and cut the cable at this point, see figure 49.
5. Thread the ends of the cable through the end of the spring. Pull the cable tight so there is 3/4" to 1" (20 to 25 mm) of stretch in the spring. Clamp the cable to form a loop and cut off any excess, see figure 49.

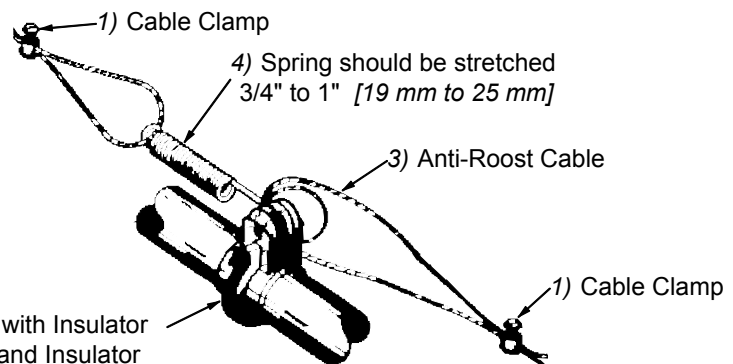

Figure 49. Anti-Roost Cable at the Hopper

6. Attach the cable to the insulator. For best results, make a double loop around the anti-roost insulator in the center groove of the insulator and fasten with a 1/16" cable clamp as shown in Figure 49.
7. Run the cable to the next insulator, attach a spring in the center groove at the anti-roost bracket and cut the cable at this point. The cable should be positioned in the insulator built into the top of each grill support along the feeder line.
8. Repeat this installation until the anti-roost cable is installed along the feeder line.
9. At the control unit, after clamping the cable to the spring, cut the cable 8" to 10" (200 to 250 mm) longer than necessary. Feed the end of the cable through the center of the spring, around the first insulator on the control unit, and clamp the cable using the cable clamp supplied with the control unit, see figure 50.
10. Install the wire from on the control unit insulators. Be sure the guard snaps into the retainers molded into the insulators, see figure 50.

11. Install the poultry trainer or line charger, as shown in **Figure 51** or **Figure 52**.

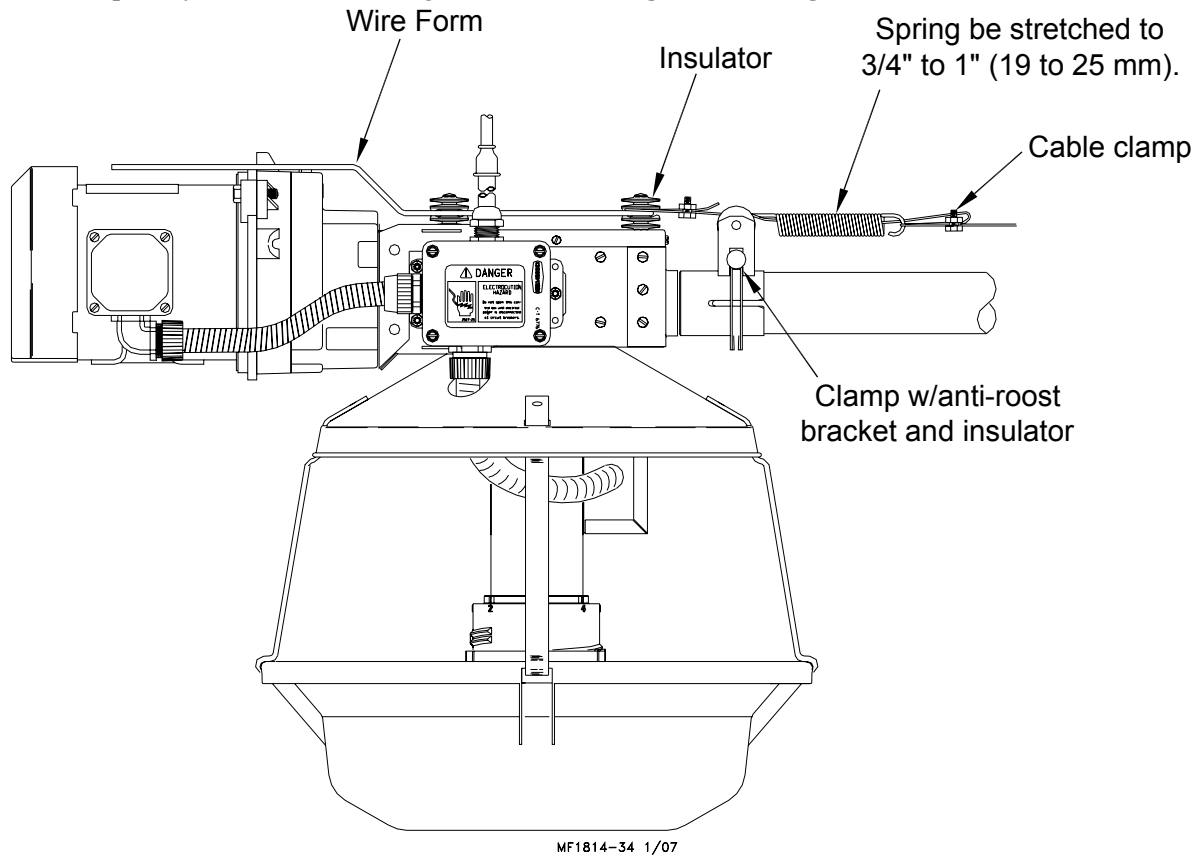

Figure 50. Anti-Roost Installation at the Control Unit

12. Route the charger wire from the poultry trainer or line charger to the anti-roost system. Secure the charger wire to the anti-roost cable, using a cable clamp.

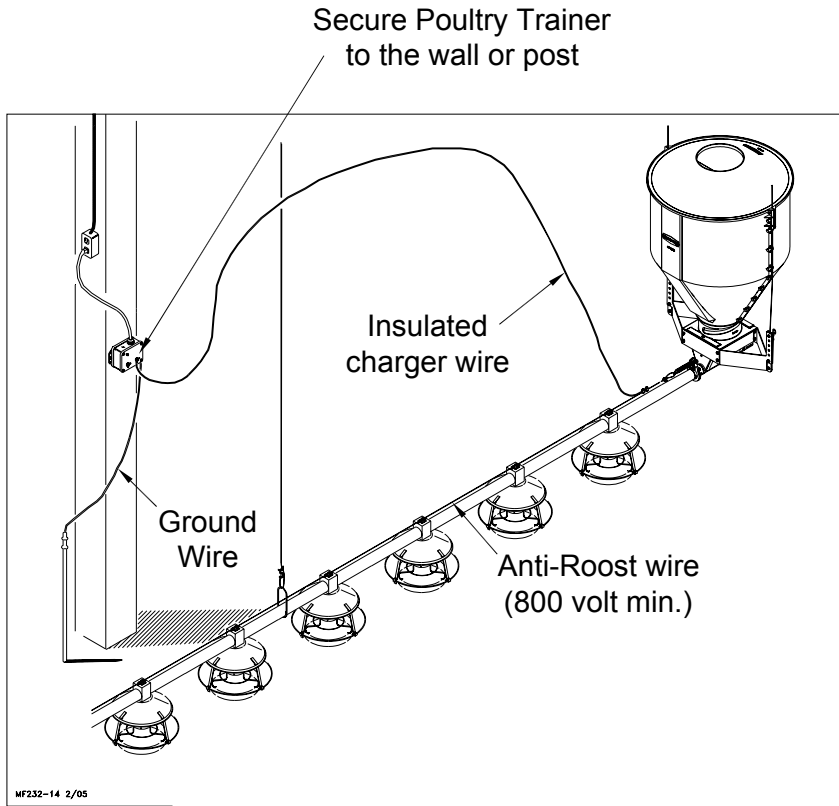

Figure 51. Poultry Trainer Installation

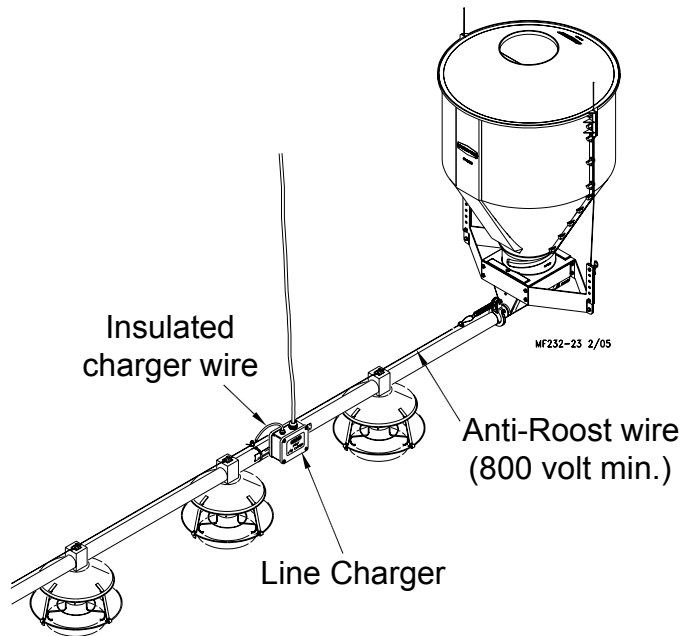

Figure 52. Line Charger Installation

13. The anti-roost system must be on a separate electrical circuit, allowing the system to be disconnected by a switch near the door.

Remember, the anti-roost system should be grounded through the poultry trainer.

Wiring Diagrams

End & Mid-Line Control Wiring Diagrams: Single Phase(Ø)

Single Phase(Ø) Wiring Diagram

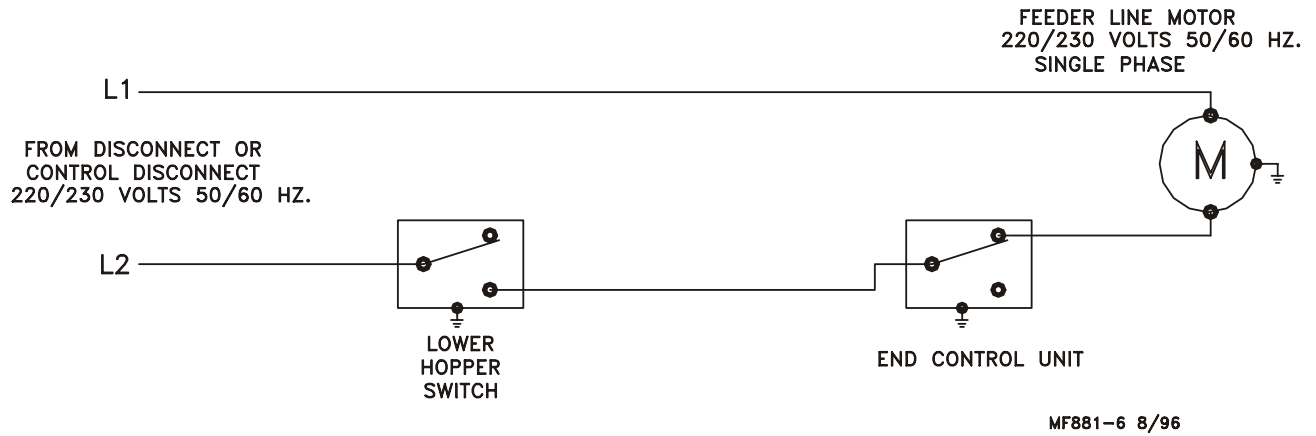

Single Phase(Ø) Wiring Diagram w/Motor Starter

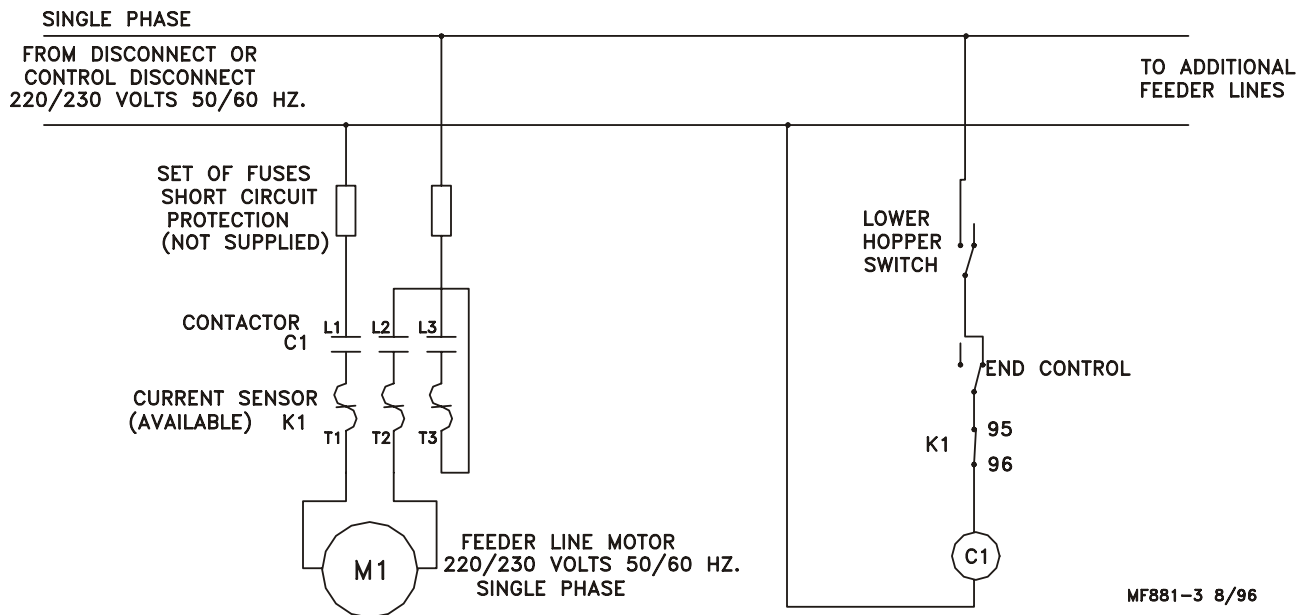

End & Mid-Line Control Wiring Diagrams: Three Phase(Ø)

Three Phase(Ø) Wiring Diagram: 220/230 V.

FROM DISCONNECT OR
CONTROL DISCONNECT
220/230 VOLTS 50 HZ.
THREE PHASE

TO ADDITIONAL
FEEDER LINES

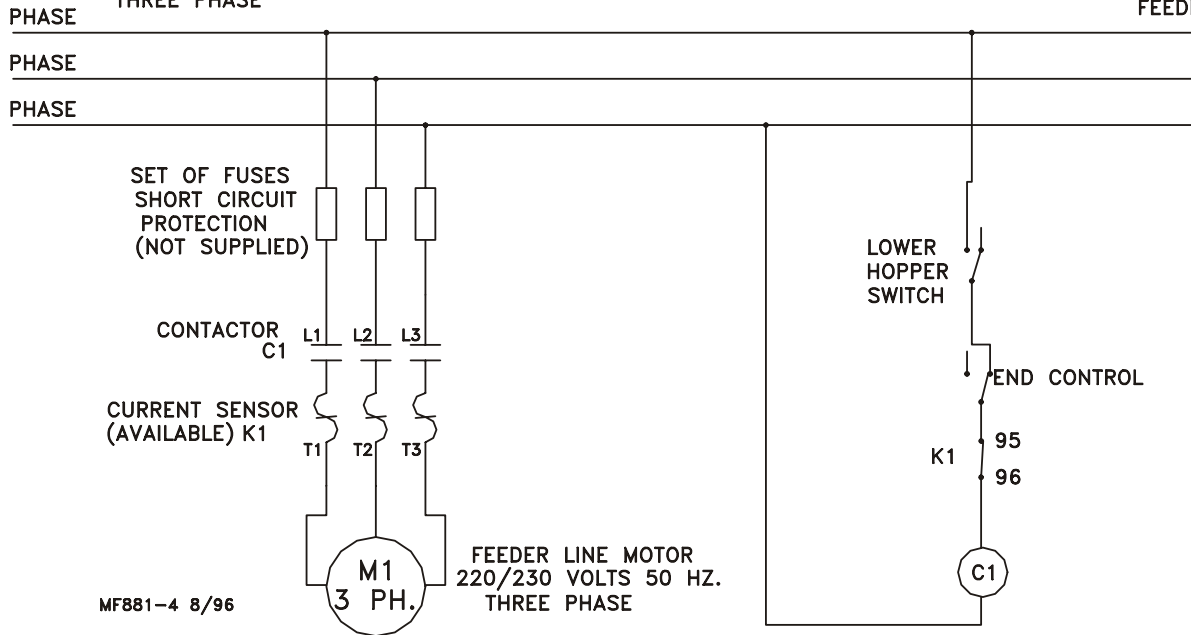

Three Phase(Ø) Wiring Diagram: 380/415 V.

FROM DISCONNECT OR
CONTROL DISCONNECT
380/415 VOLTS 50 HZ.
THREE PHASE

TO ADDITIONAL
FEEDER LINES

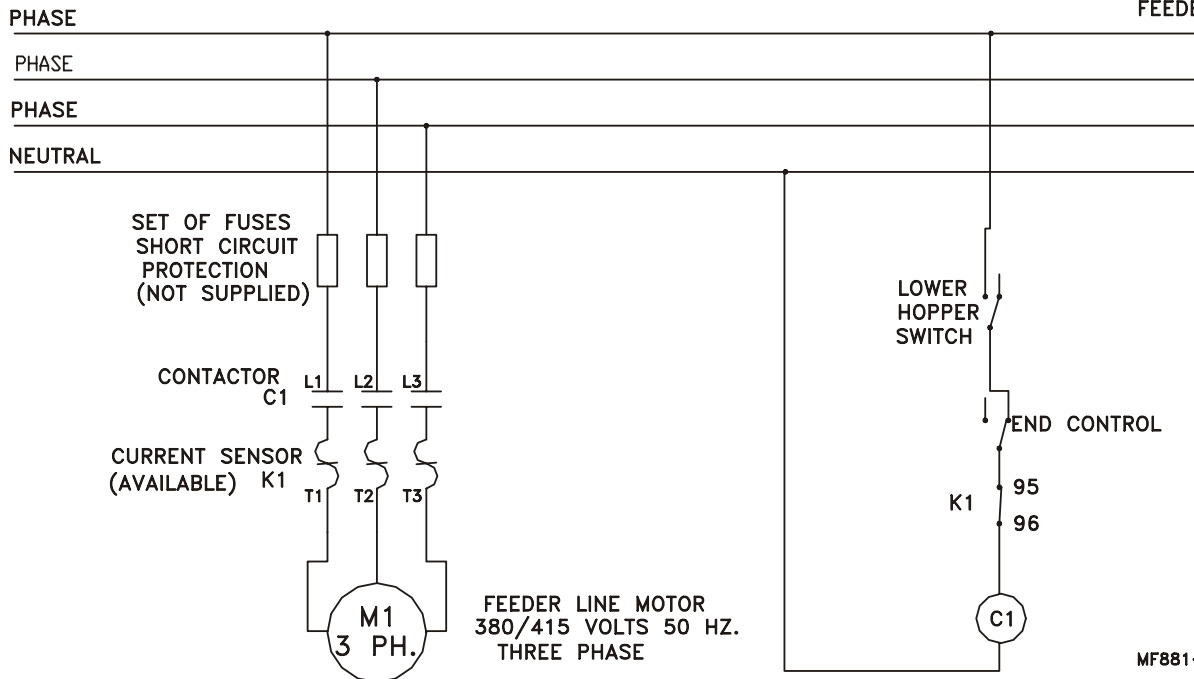

SENSOR PLUS™ Internal Wiring

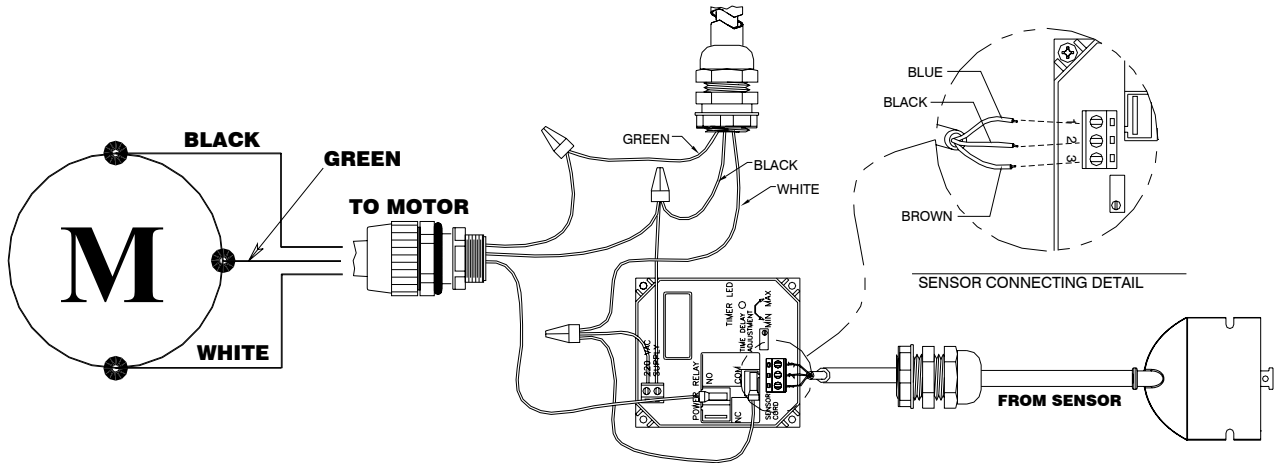

WIRING DIAGRAM

SENSOR PLUS™ Control Wiring Diagram

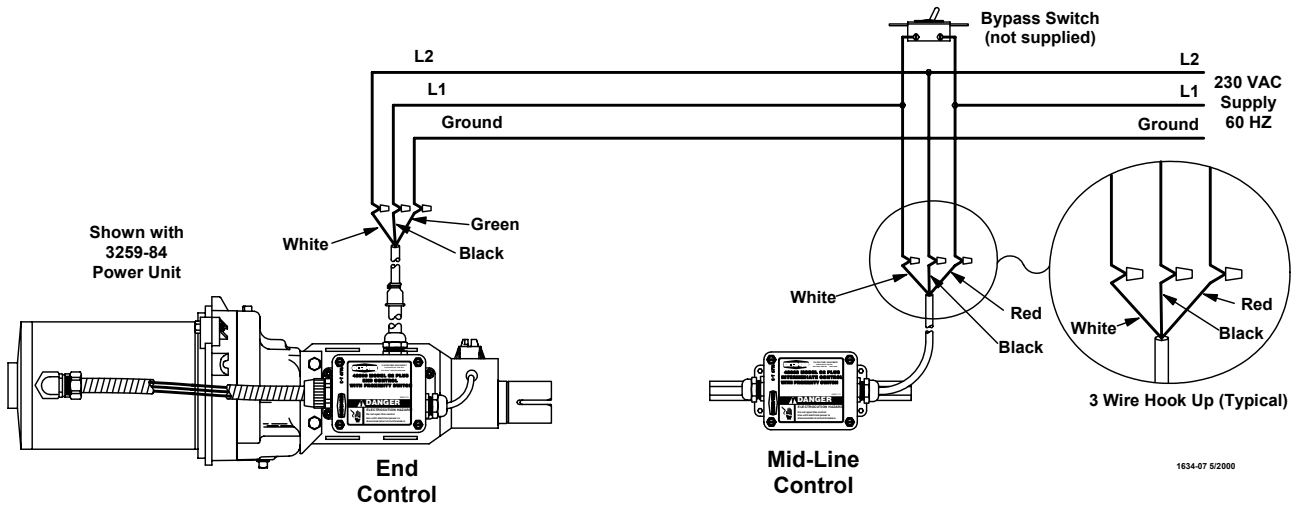

1634-07 5/2000

Sensor Plus™ Three Phase(Ø) Wiring

FROM DISCONNECT OR CONTROL DISCONNECT
220/380 VOLTS 50 HZ.
THREE PHASE

TO ADDITIONAL FEEDER LINES

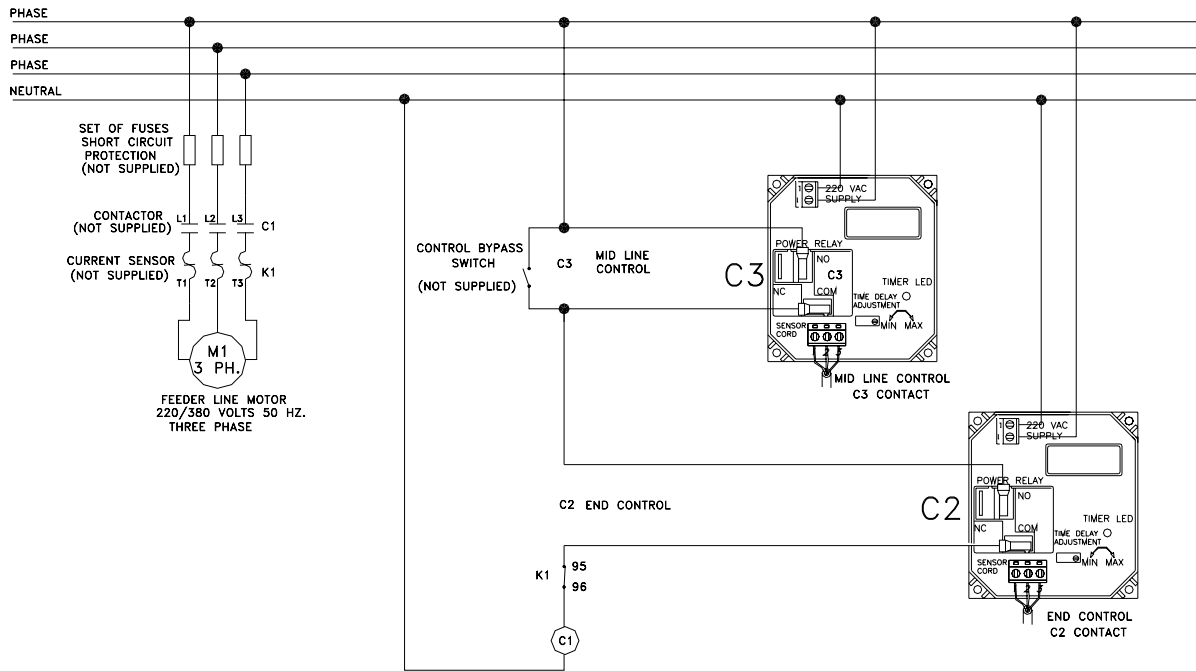

232-62 4/05

Mid-Line Control Internal Wiring

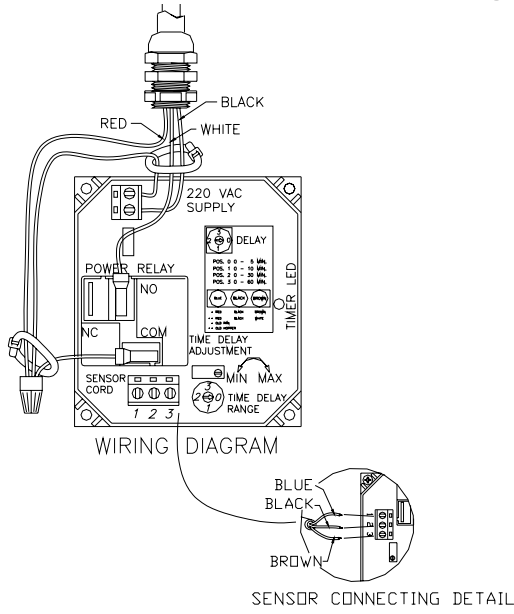

Maintaining the Feeding System

Floor Feeding System Maintenance

The MODEL ATF™ and MODEL ATF™ PLUS require minimum maintenance. However, a routine periodic inspection of the equipment will prevent unnecessary problems.

Maintenance should be done by a qualified technician.



ALWAYS DISCONNECT POWER TO THE SYSTEM WHEN SERVICING OR MAINTAINING THE EQUIPMENT. FAILURE TO DISCONNECT POWER MAY CAUSE INJURY OR DEATH.

Gear Head Maintenance

Refer to **Figure 53**.

Check the oil level in the gear heads at installation and every 6 months. The Pipe Plug, on the side of the gear head, indicates proper oil level. Add SAE 40W oil when necessary.

The oil in the gearheads should be replaced every 12 months with new SAE 40W oil

- A. Remove the bottom pipe plug to drain the oil. Discard used oil in accordance with local and national codes.
- B. Wipe any debris off the magnet on the bottom pipe plug and reinstall. Remove the side pipe plug and (top) vent plug.
- C. Set the power unit in the horizontal position.
- D. 2-Stage Gearheads: Add approximately 9 oz. (266 ml) of SAE 40W oil through top hole. This should be just enough oil to reach the side pipe plug.
3-Stage Gearheads (3261-9, 3261-12, 3261-14): Add approximately 13 oz. (384 ml) of SAE 40W oil through top hole. This should be just enough oil to reach the side pipe plug.
- E. Install the side pipe plug and (top) vent plug.

1)Vent/Oil Fill Plug

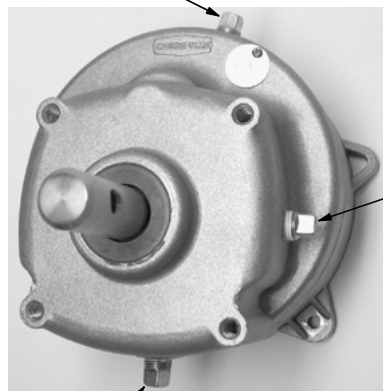

2)Oil Drain Plug

Check the oil level in the gear head at installation

Check the oil level every 6 months

3)Check the oil level at the side plug
If oil is needed use SAE 40W oil

Oil capacity for the 2 stage gear head is 9 oz [266 ml]

Oil capacity for the 3 stage gear head is 13 oz [384 ml]

The oil should be changed every 12 months

1660-22 1/2001

Figure 53. Gearhead Maintenance

Check equipment for loose hardware after the first flock and then every 6 months--including the anchor block. Tighten if necessary.

Switch Adjustment procedure for the Control Units

- A. Turn the adjustment screw counter-clockwise until the switch clicks.
- B. Turn the adjustment screw clockwise until the switch clicks.
- C. Turn the adjustment screw counter-clockwise 3/4 turn.

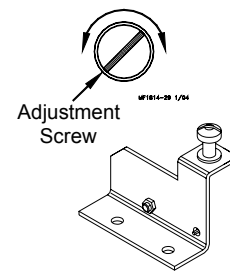

Figure 54. Switch Adjustment

SENSOR PLUS™ Sensor Switch Adjustment for Control Units

The SENSOR PLUS™ pan half round sensor switch is adjusted at the factory to a sensitivity of .25" [6 mm] from the face of the sensor and a time delay of 15 seconds with the range selector in the "0" position. The time delay adjustment is 0 seconds to 5 minutes.

To adjust the time delay (see figure 55.):

- For less time — turn time delay adjusting screw counter-clockwise (Light blinks fast)
- For more time — turn time delay adjusting screw clockwise (Light blinks slow)

Feeder Line

Keep anti-roost cables tightly stretched. This increases the effectiveness of the electro-guard anti-roost system and keep the pans from being tilted when birds push against them.

Remove all feed from the feeder when there are no birds in the house and when the building is washed and disinfected.

Turn the feeders off prior to removing the birds from the house. This will allow them to clean the feed out of the pans.

If the system is not to be used for an extended period of time, remove all the feed from the feeder lines and feeder pans.

Disconnect power to the system to prevent accidentally starting the system.

If the system must be disassembled, extreme caution must be used to prevent injury from springing auger.

1. Disconnect power to the entire system.
2. Loosen the tube clamp on the bearing at the hopper end of the system. Remove the tube clamp and bearing retainer.
3. Pull the anchor and bearing assembly and approximately 18" [45 cm] of auger out of the boot.

CAUTION: Stand clear...the auger may spring back into the tube.

4. Place a clamp or locking pliers securely on the auger to prevent it from springing back into the auger boot.
5. Loosen the setscrew in the bearing assembly shaft and remove the anchor and bearing assembly from the auger.

To reinstall the Anchor and Bearing Assembly:

1. Insert the anchor assembly into the auger until it touches the washer at the back of the anchor. Tighten the setscrews in the center of the anchor until they touch the auger, then tighten a maximum of 1/2 turn. See Figure 56.
2. **DO NOT OVERTIGHTEN THE SET SCREWS.**
3. **Carefully** remove the locking pliers while holding onto the anchor and bearing assembly and auger securely. **Slowly** ease the auger back into the tube. Use caution. If the auger is allowed to spring back, the bearing race may crack.

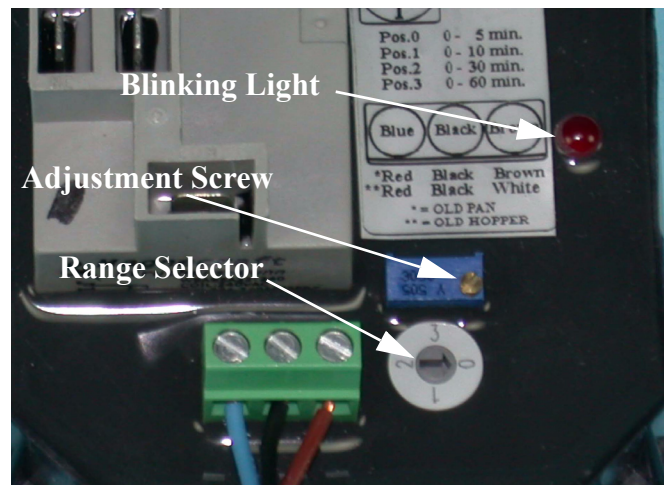
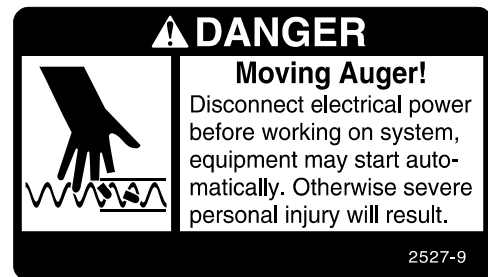

Figure 55. Adjusting Sensor Plus Proximity Switch



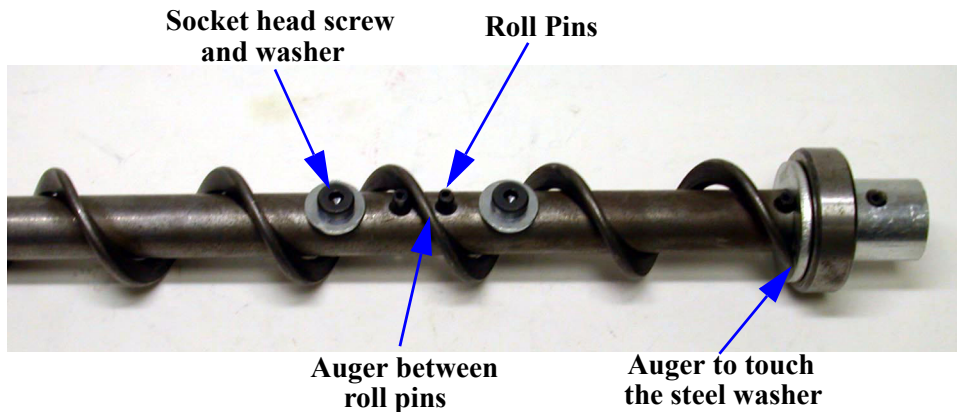

Figure 56. Auger and anchor Bearing Connection

Install the bearing retainer and fasten with a tube clamp. Keep the bearing retainer flush with the end of the anchor for safety.

Power Lift Winch Maintenance

Refer to **Figure 57**.

Grease the winch every 6 months with 1 to 2 shots of common industrial or automotive grease.

DO NOT OVER GREASE THE WINCH.

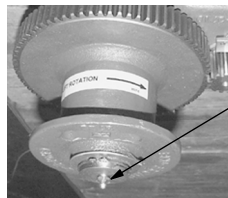

1) Grease the Power Lift Winch every 6 months with 1 to 2 shots of common industrial or automotive grease
DO NOT OVER GREASE THE POWER LIFT WINCH

1660-24 6/2001

Figure 57. Maintenance to the Power Lift Winch

Remove any feed build-up in the Safety Switch Boxes in the Control Units.

It may be necessary to periodically retighten the shocker cable. Be sure to disconnect power to the shocker before servicing the equipment.

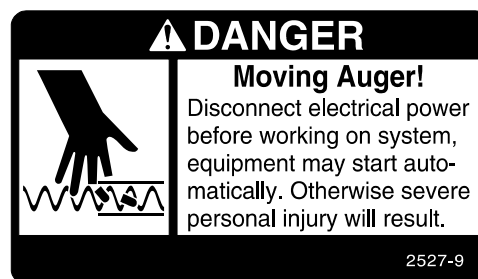
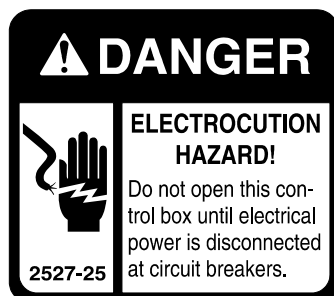

Trouble Shooting the Feeding System

ALWAYS DISCONNECT POWER TO THE SYSTEM WHEN SERVICING OR MAINTAINING THE EQUIPMENT. FAILURE TO DISCONNECT POWER MAY CAUSE INJURY OR DEATH.

Service and maintenance work should be done by a qualified technician only.

Problem	Possible Cause	Corrective Action
None of the feeder lines will operate.	No power supplied to equipment.	Replace burned fuses or reset circuit breaker. Make sure voltage required is supplied.
	Time clock or relay defective.	Replace time clock or relay.
	Time clock improperly programmed.	Refer to programming the time clock section and reprogram the time clock.
Feeder line will not operate.	Power unit cord not plugged in sufficiently to make contact.	Check motor cord plug at control unit and control unit plug at outlet for connection.
	Motor cord wires are broken at plug or where cord enters motor.	Check cord for continuity, replace if defective.
	Power units thermal overload tripped.	Push motor overload reset button to reset.
	Control unit switch defective or out of adjustment.	Adjust switch according to the switch adjustment procedure in the maintenance section.
Motor overloads frequently.	Oil on new auger loads motor excessively when feed is carried for first time.	Polish auger by running 50 lb. (20 kg) increments of feed out to pans.
	Inadequate power reaching motors.	Check line voltage at the motors. Wiring of adequate size is essential to feeder operation.
	Object caught in the auger; motor runs, stalls, then auger spins in reverse.	Check hopper boot, control unit and pan outlets. Remove obstruction.
Auger runs erratically.	Frozen or cracked bearing at boot anchor.	Replace bearing. Slowly ease auger back into tube. Be careful no to damage the bearing when reinserting the auger.
	Insufficient stretch in auger.	Shorten the auger.
	Obstruction in auger.	Remove obstruction.
Auger tube or boot wears out rapidly (Noisy feeder operation)	Auger is bent or kinked	Repair or replace damaged auger.
	End of auger is riding up on anchor weldment.	Auger must not be positioned over weld on anchor. Check for bent or damaged auger.
Oil leaking out of seals on power unit	Gearhead vent plug not installed.	Replace plastic shipping plug with vent plug.
	Defective gear head seal.	Replace seal.
Not enough feed supplied to the feeder pans.	Insufficient time programmed on the time clock.	Add more operating time to feeding period.
	Feeder line control unit switch out of adjustment.	Adjust switch according to the switch Adjustment procedure in the maintenance section.

Parts Listing

150# Hopper Components

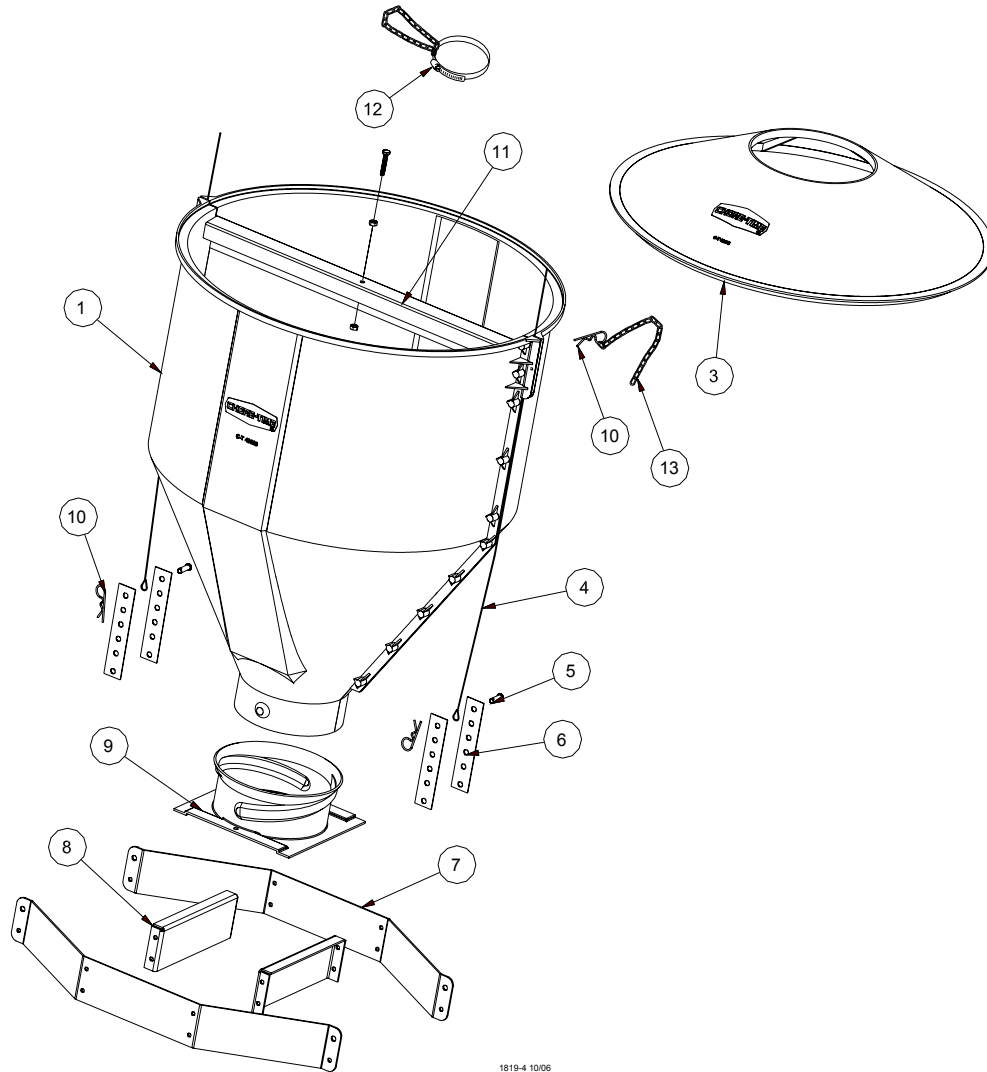

1819-4 10/06

Key	Description	Without Cover 48926	With Cover 49267
1	Hopper Half	49028	49028
2	--	--	--
3	Cover	--	48675
4	Cable Assembly	2809-3	2809-3
5	Clevis Pin	2797-1	2797-1
6	Adjustment Bracket	2706	2706
7	Suspension Angle	48679	48679
8	Suspension Brace	48680	48680
9	Twist Lock Collar	49041	49041
10	Hairpin	2664	2664
11	Brace	49029	49029
12	Tube Support Assembly	14367	14367
*13	Chain	2128	2128

*Item must be ordered in either 100 ft or 250 ft quantities, 2128-100 is 100 ft and 2128-250 is 250 ft.

Hopper Mount Bracket (Optional)

Part No. 49358 Hopper Suspension Kit

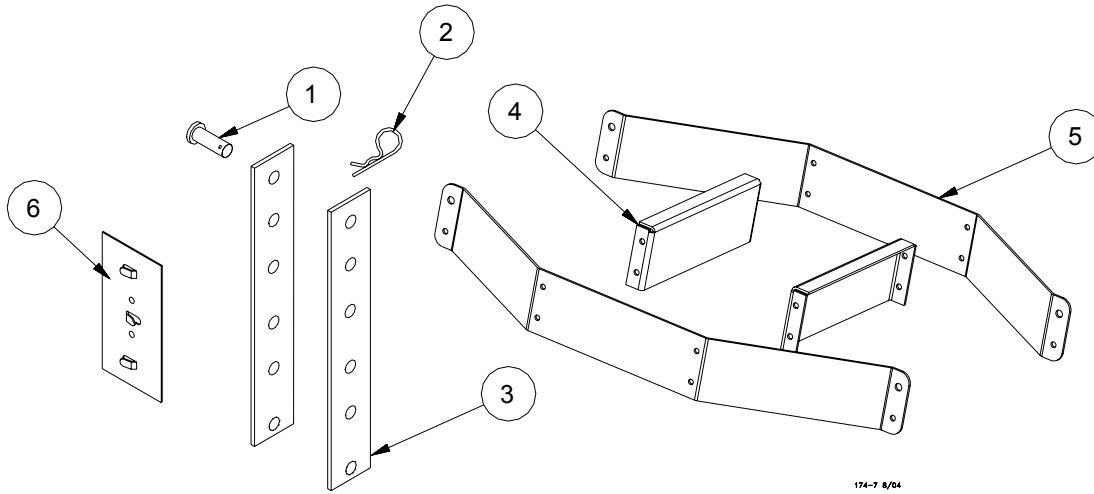

174-7 8/04

Item	Description	Part No. Single Boot Kit	Part No. Twin Boot Kit
1	Clevis Pin, 5/16" x 1"	2797-1	2797-1
2	Adjustment Bracket	2706	2706
3	Hair Pin	2664	2664
4	Suspension Brace	48680	48680
5	Suspension Angle	48679	48679
6	Cable Guide	34573	34573

***This kit is used for for steel hopper suspension.**

Single Boot Components Part No. 6821

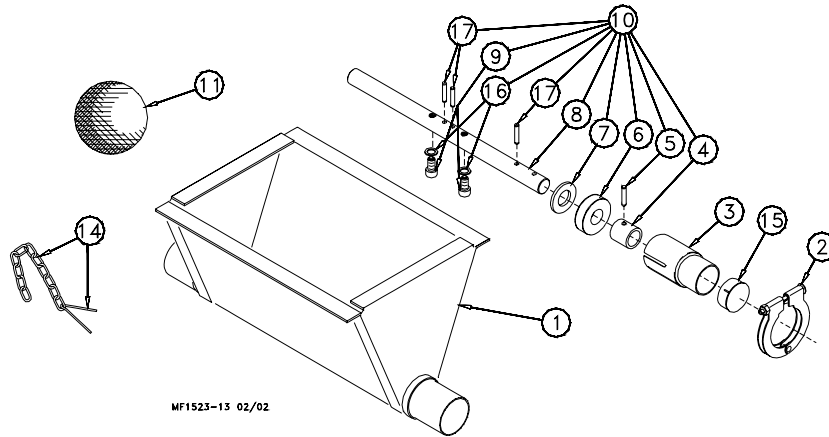

MF1523-13 02/02

Item	Description	Part No.	Item	Description	Part No.
1	Boot Weldment	4224	10	Anchor and Bearing Ass'y	39372
2	Tube Clamp	24062	11	Cannonball	3531
3	Outlet Tube	4556	12	---	---
4	Sleeve	5648	13	---	---
5	3/16 x 1" Pin	2960-1	14	Latch Pin Ass'y	2683
6	Bearing	2689	15	Cap	29373
7	Washer	2955-14	16	Flat Washer	2955-58
8	Anchor	38540	17	Roll Pins	2960-1
9	5/16-18 x 7/8 Low head cap screw	47867	--	Danger Decal	2527-9

Twin Boot Components Part No. 8460

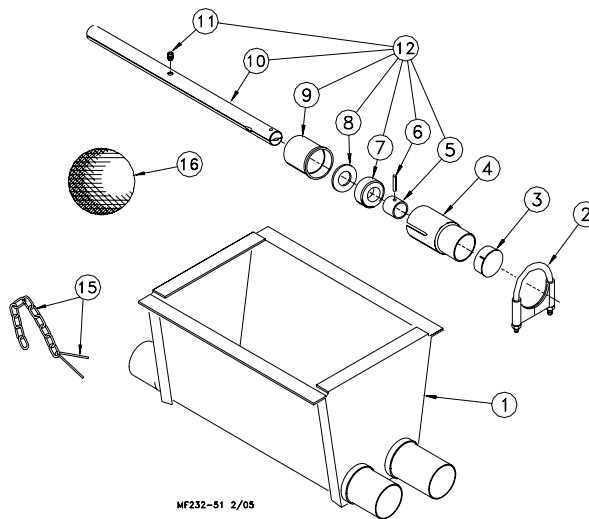

MF232-51 2/05

Item	Description	Part No.	Item	Description	Part No.
1	Boot Weldment	8461	10	Anchor	29526
2	Tube Clamp	29520	11	Set Screw	1174
3	Cap	29523	12	Anchor and Bearing Ass'y	29530
4	Stub Tube	4163	13	---	---
5	Sleeve	5648	14	---	---
6	3/16 x 1" Pin	2960-1	15	Latch Pin Ass'y	2683
7	Bearing	29433	16	Cannonball	3531
8	Washer	2955-14	---	Danger Decal	2527-9
9	Bearing Retainer	29441			

Feeder Line Components

Item	Description	Part No.
1*	Auger	6820-0
2	ATF Auger Tube (1-Hole Tube)	6684
	ATF Auger Tube (2-Hole Tube)	6685
	ATF Auger Tube (3-Hole Tube)	6686
3	Anti-Roost Bracket	29516
4	Clamp	29520
5	Line Charger	29317
6	Hanger	4207
7	Split Bolt	6342
8	Spring	7551
9	3/32" Cable	4973
10	Charger Wire (165 ft.)	28994-165
	Charger Wire (330 ft.)	28994-330
11	Poultry Trainer	29333
12	3/8" Hex Nut	1549
13	3/8" Flat Washer	4976

***Round up to the nearest 10'. Auger lengths from 50 to 500 feet. Example: 6820-200 would be a 200' roll of Auger**

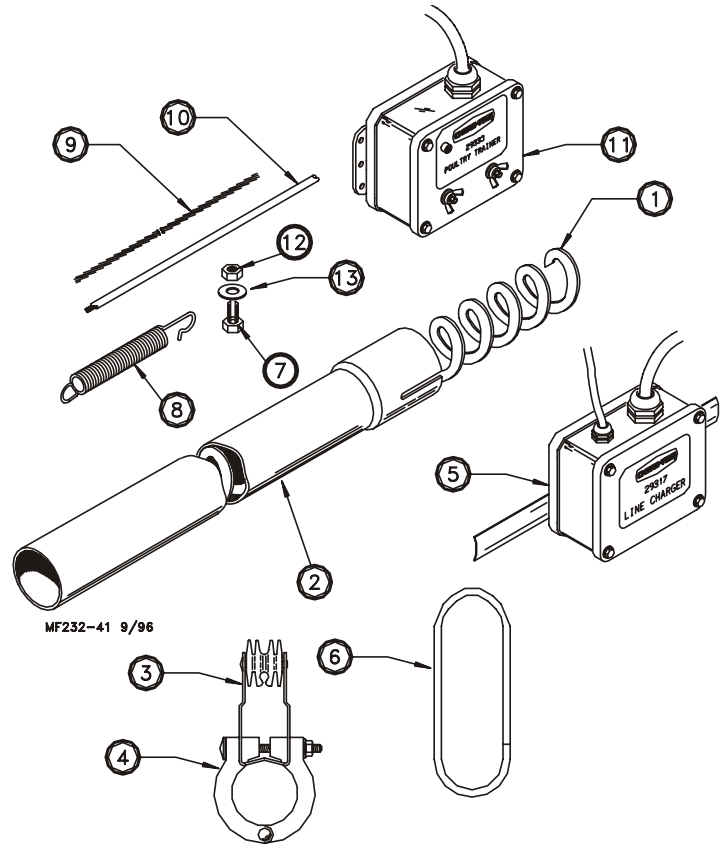

Power Unit Components

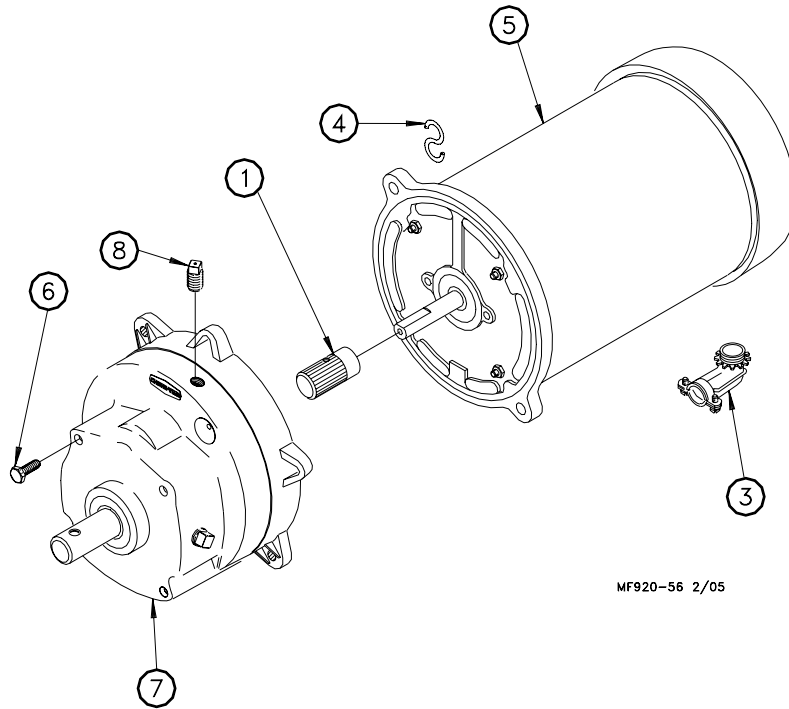

		3259-34	3259-39	3259-98	3259-100
Item	Description	Part No.	Part No.	Part No.	Part No.
1	Pinion Assembly	5046	5046	5046	5046
2	Cord Assembly	----	----	28028	----
3	Connector (90 Degree)	4228	4228	4228	----
4	"S" Hook	2805	2805	2805	2805
5	Motor	4229	5703	5977	28031
6	5/16-18 x 5/8 Hex Hd Screw	4412-1	4412-1	4412-1	4412-1
7	Gearhead	3261-5	3261-5	3261-11	3261-11
8	Pipe Plug	3516	3516	3516	3516

Power Unit Assembly Part Numbers

Part Number	HP	RPM	Phase	Hz	Voltage	Usages
3259-34	1/3 HP	348 RPM	Single Phase	60 Hz	230	Use with both Control Units
3259-39	1/2 HP	348 RPM	Single Phase	60 Hz	230	Use with both Control Units
3259-98	1/2 HP	348 RPM	Single Phase	50 Hz	230	Use with both Control Units
3259-100	1/2 HP	348 RPM	Three Phase	50 Hz	220/380	Use with both Control Units

MODEL ATF™ End Control (SENSOR PLUS™): 50356

MODEL ATF™ PLUS End Control (SENSOR PLUS™): 50357

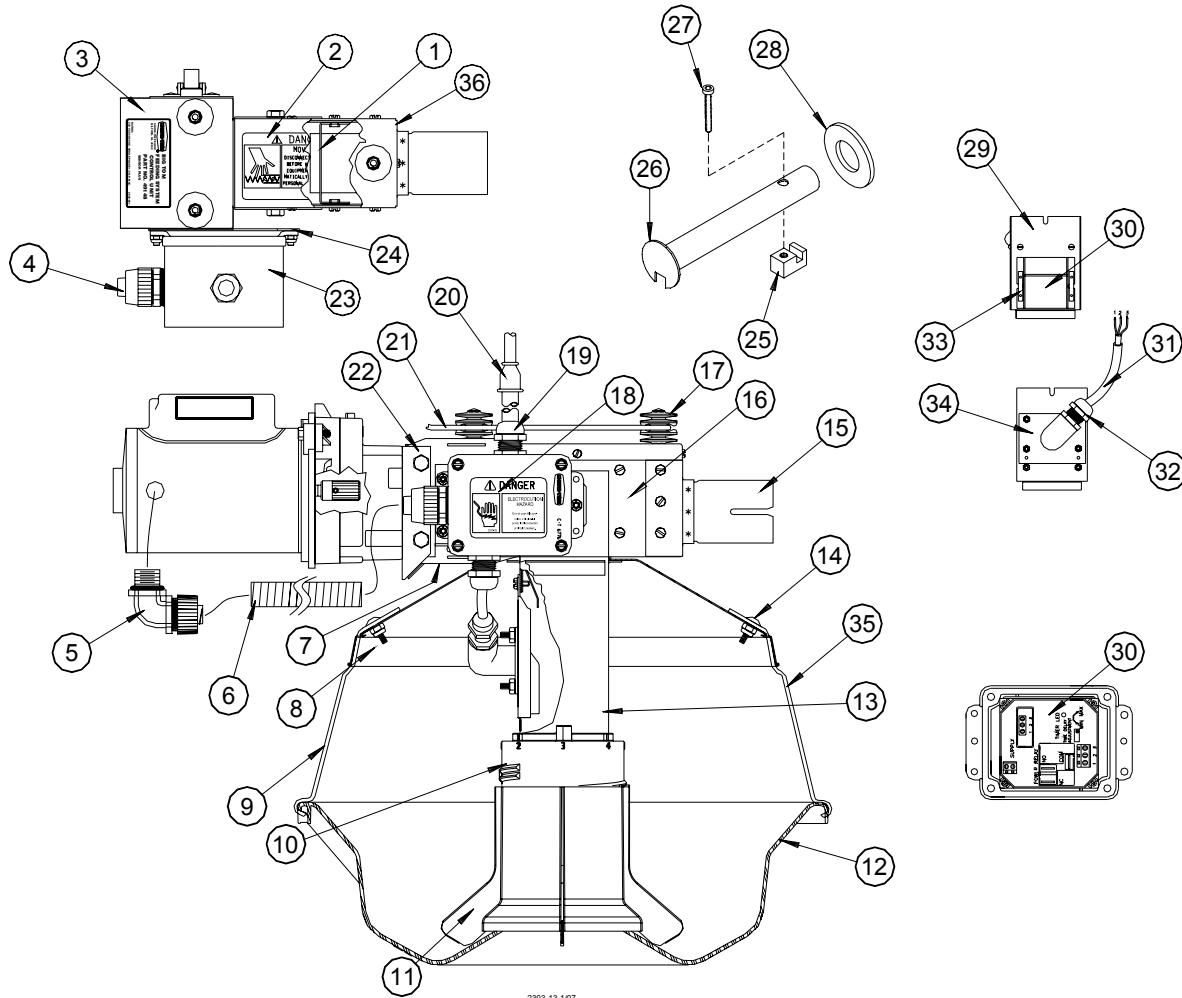

2303-13 107

Item	Description	50356 Part No.	50357 Part No.
*1	Tube Support	27891	27891
*2	Danger Decal	2527-9	2527-9
3	Safety Cover	27941	49043
4	1/2" Conduit Connector	26980	26980
5	90° 1/2" Conduit Conn.	23810	23810
6	1/2" Flex Conduit	26982-1	26982-1
7	Bottom Cover	27893	49044
8	Pan Shield	4191	49138
9	Pan Support	4199	49171
10	Feed Cones	50359	50359
11	Feed Cones	50359	50359
12	Feed Pan (Plastic)	29000	29000
13	Control Drop Tube	4180	49145
14	Drive Rivet	4200	---
	1/4-20 Bolt	---	22692
*15	Stub Tube Weldment	27900	27900
*16	Control Body	27889	49042
17	Insulator	2976	2976
18	Product ID/Danger Decal	2529-734	2529-734

Item	Description	50356 Part No.	50357 Part No.
19	1/2" Watertight Connector	24685	24685
20	Cord Assembly	4999-100	4999-100
21	Anti-Roost Guard	2798	2798
22	Anchor Plate	4188	4188
23	Junction Box	42627-8	42627-8
24	Switch Mounting Plate	43815	43815
25	Drive Block	4642	4642
26	Drive Tube Weldment	47584	47584
27	1/4-20 x 1 1/2" Socket Hd Screw	5083-8	5083-8
28	Flat Washer	1484	1484
29	Adapter Plate	43813	43813
30	Sensor Plus Level Switch	48579	48579
31	Black Tubing	14454-10	14454-10
32	1/2" Watertight Connector	23779	23779
33	Sensor Retainer	46728	46728
34	Plastic Adapter Plate	43819	43819
35	Pan Support (Swing-Down)	24274	49172
*36	Top Body Cover	27942	27942

* These Items may be ordered as an assembly: ATF Part No. 43818, ATF PLUS Part No. 49045

MODEL ATF™ End Control (Mech. Switch): 50355

MODEL ATF™ PLUS End Control (Mech. Switch): 50358

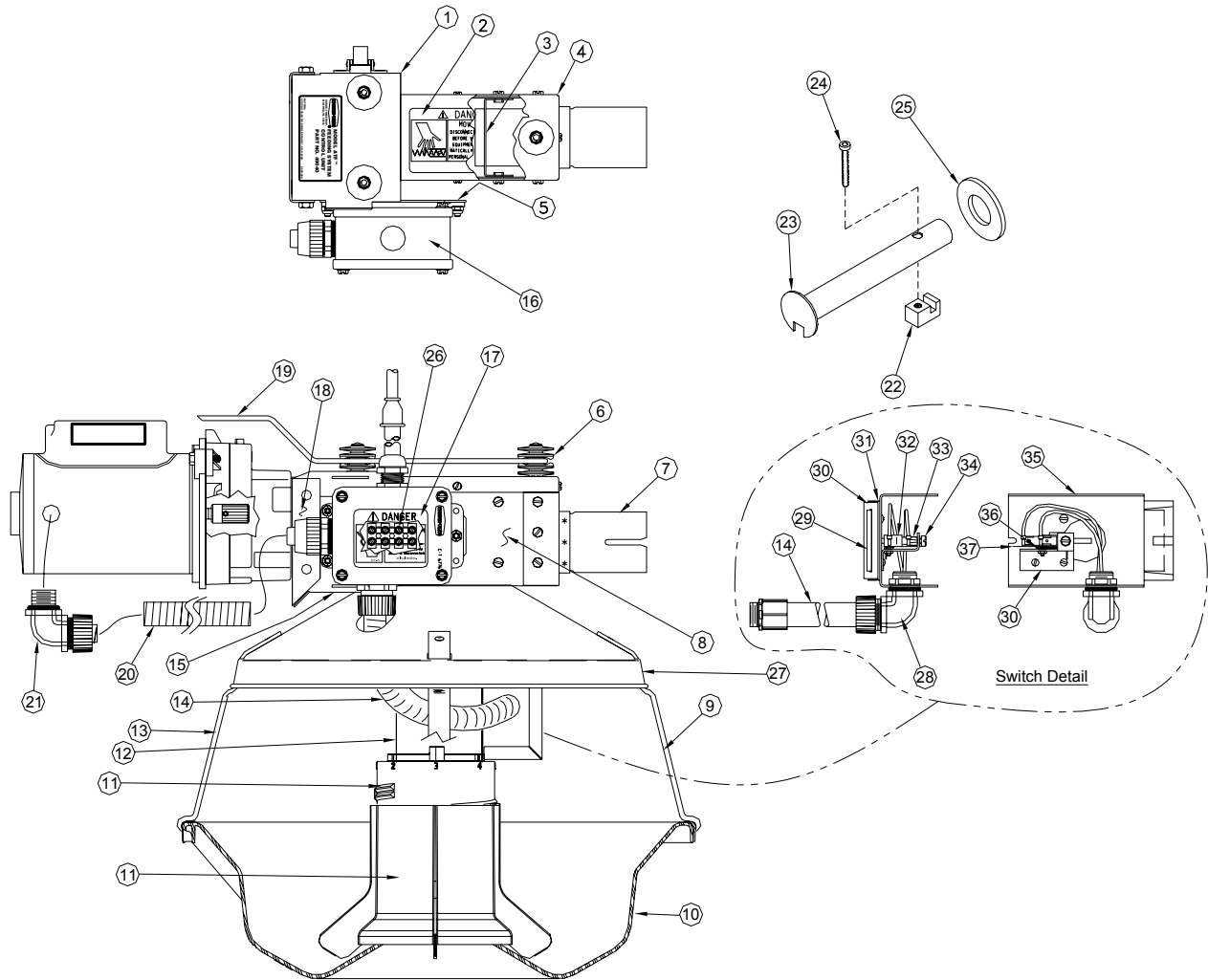

Item	Description	50355 Part No.	50358 Part No.
1	Safety Cover	49043	49043
*2	Danger Decal	2527-9	2527-9
*3	Tube Support	27891	27891
*4	Body Cover	27942	27942
5	Switch Mount Plate	43815	43815
6	Insulator	2976	2976
*7	Stub Tube Weldment	27900	27900
*8	Control Body	49042	49042
9	Pan Support	4199	49171
10	Feeder Pan (Plastic)	29000	29000
11	Feed Cones	50359	50359
12	Control Drop Tube	4180	49145
13	Pan Support (Swing Down)	24274	49172
14	Conduit Assembly	27866	27866
15	Bottom Cover	49044	49044
16	Junction Box	36334-5	36334-5
17	Danger Decal	2527-25FE	2527-25FE
18	Anchor Plate	4188	4188
19	Anti-Roost Guard	2798	2798

Item	Description	50355 Part No.	50358 Part No.
20	Flex Conduit	26982-1	26982-1
21	90° 1/2" Conduit Conn.	23810	23810
22	Drive Block	4642	4642
23	Drive Tube Weldment	47584	47584
24	1/4-20 x 1 1/2" Screw	5083-8	5083-8
25	Flat Washer	1484	1484
26	Terminal Block	34925-4	34925-4
27	Pan Shield	4191	49138
28	90° Conduit Conn.	24726	24726
29	Paddle	4890	4890
30	Diaphragm Assembly	4889	4889
31	Spacer Plate	4921	4921
32	Snap Action Switch	46324	46324
33	Nylon Grommet	50602	50602
34	Nylon Screw	4303-5	4303-5
35	Housing	6048	6048
36	Torsion Spring	5820	5820
37	Barrier	6936	6936
38	Switch Bracket	6046	6046

*These components may be ordered as an assembly Part No. 49045

MODEL ATF™ Mid-Line Control (Mech. Switch): 50364

MODEL ATF™ PLUS Mid-Line Control (Mech. Switch): 50363

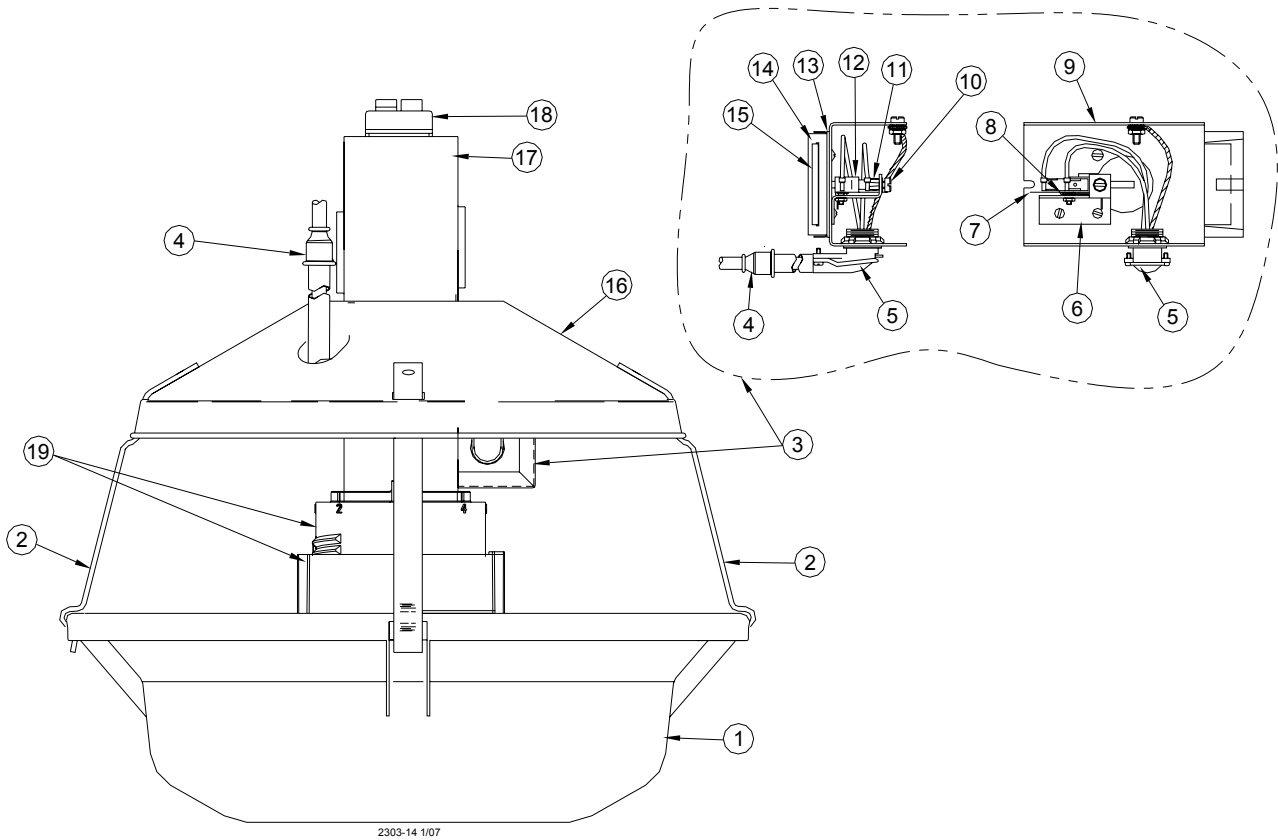

2303-14 1/07

		50364	50363
Item	Description	Part No.	Part No.
*1	Feeder Pan (Plastic)	29000	29000
*2	Pan Support	4199	49171
	Pan Support (Swing Down)	24274	49172
3	Switch Assembly	6044-4	6044-4
4	Cord Assembly	4999-111	4999-111
5	90° Connector	4228	4228
6	Switch Bracket	6046	6046
7	Barrier	6936	6936
8	Torsion Spring	5820	5820
9	Housing	6048	6048
10	Nylon Screw	4303-5	4303-5
11	Nylon Grommet	50602	50602
12	Snap Action Switch	46324	46324
13	Spacer Plate	4921	4921
14	Diaphragm Assembly	4889	4889
15	Paddle	4890	4890
*16	Pan Shield	4191	49138
17	Drop Tube	6446	49559
18	Insulator	5754	5754
19	Feed Cones	50359	50359

***These items are not included with the control assembly and must be ordered separately.**

MODEL ATF™ Mid-Line Control (SENSOR PLUS™): 50366

MODEL ATF™ PLUS Mid-Line Control (SENSOR PLUS™): 50365

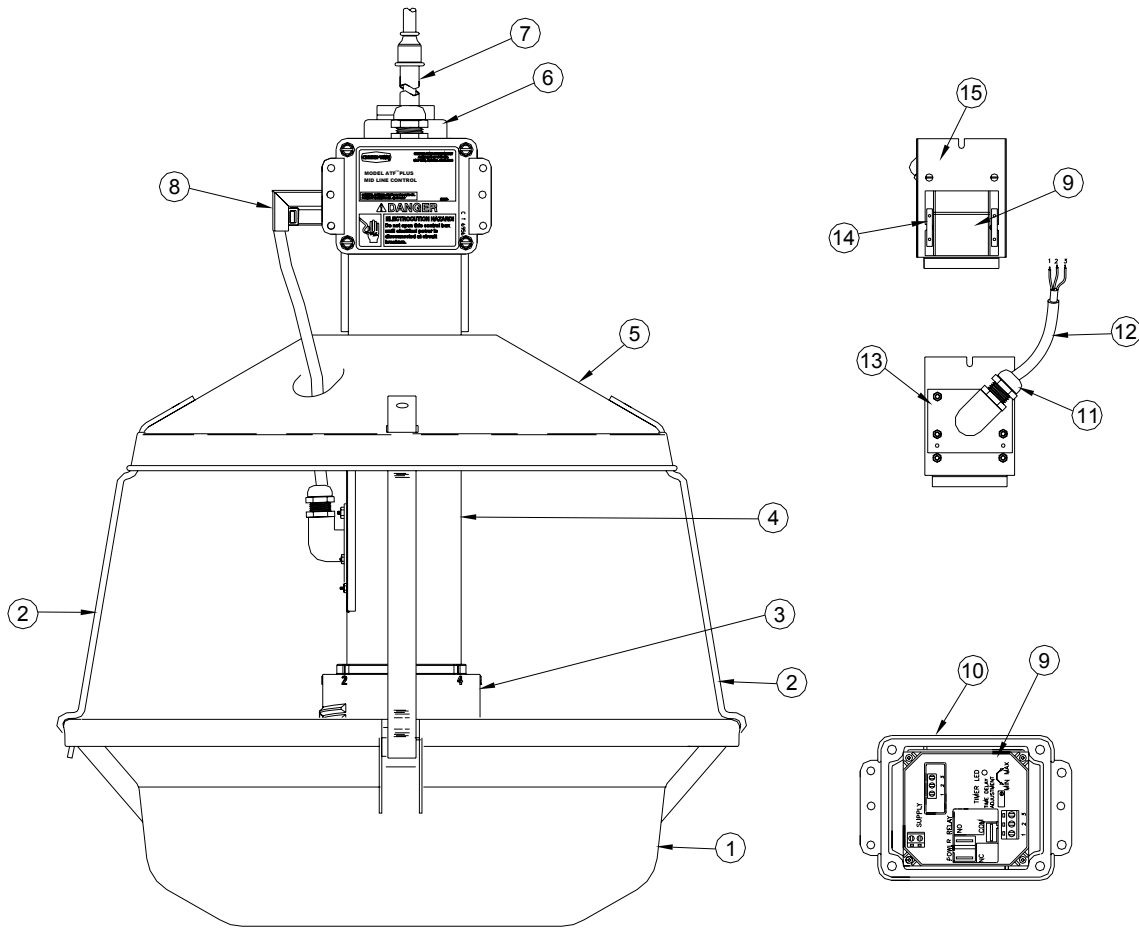

2303-15 1/07

		50366	50365
Item	Description	Part No	Part No
*1	Feeder Pan (Plastic)	29000	29000
*2	Pan Support	4199	49171
	Pan Support (Swing Down)	24274	49172
3	Feed Cones	50359	50359
4	Drop Tube	6446	49559
*5	Pan Shield	4191	49138
6	Insulator	5754	5754
7	Cord Assembly	4999-103	4999-103
8	90° 1/2" Conduit Conn.	49587	49587
9	Level Switch	48579	48579
10	Mounting Cover	6956	6956
11	Watertight Connector	24685	24685
12	Black Tubing	14454-10	14454-10
13	Plastic Adapter Plate	43819	43819
14	Sensor Retainer	46728	46728
15	Adapter Plate	43813	43813

***These items are not included with the control assembly and must be ordered separately.**

Feed Level Tube Winch Kit Part No. 46218

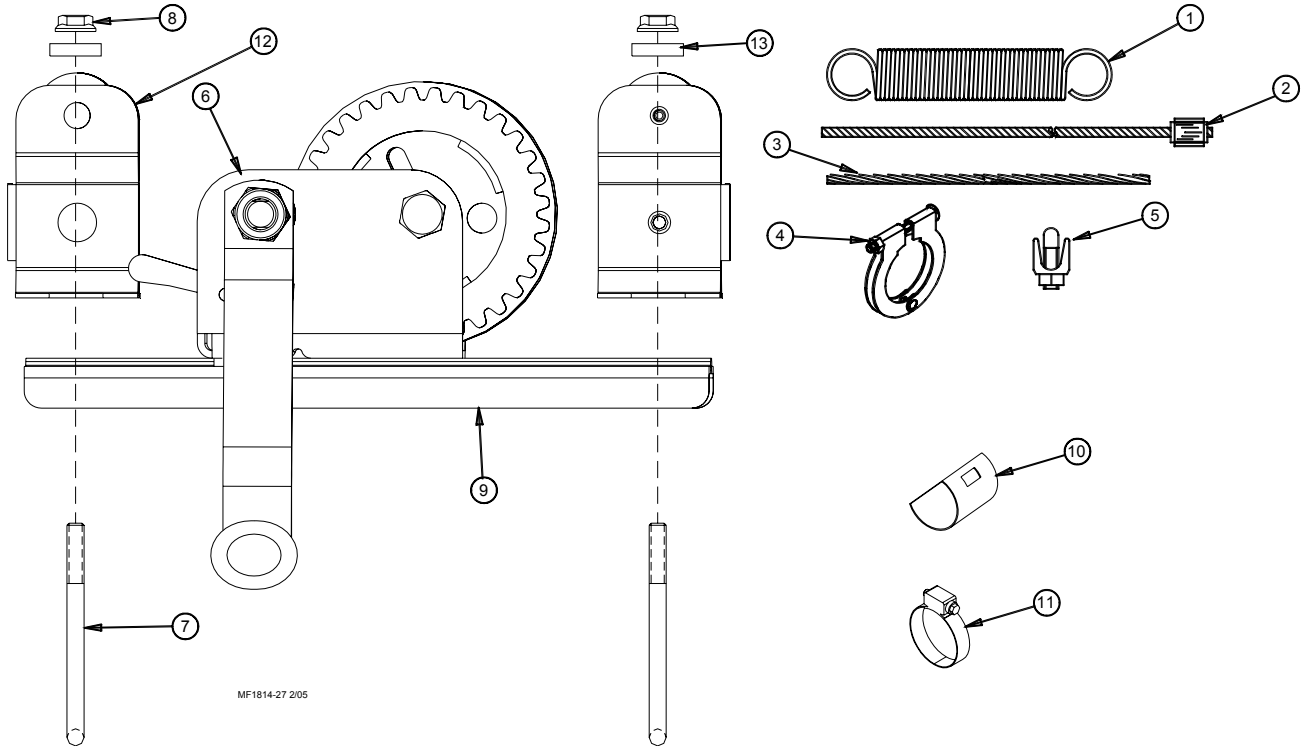

Item	Description	Part No.
1	Spring .62 x 11"	24302
2	Cable Assembly	14278
3	3/32" 7 x 19 Golf. Cable	28394
4	2" Tube Clamp	29520
5	1/8" Cable Clamp	14898
6	Feed Level Tube Winch	43391
7	1/4" x 20 U Bolt	7975
8	1/4" x 20 Flange Nut	46298
9	Winch Base Assembly	48933
*10	Tube Closure	9126
*11	Adjustment Clamp	3527
12	Insulator Bracket	49230
13	Washer	5933

*These parts may be ordered as a kit under Part No. 14585.

MODEL ATF™ Drop Tube Repair Tube Part No. 49160

MODEL ATF™ PLUS Drop Tube Repair Tube Part No. 49163

Item	Description	49160	49163
		Part No	Part No
1	Drop Tube	49159	49164
2	Spacer	49155	49155
3	Insulator	5754	5754

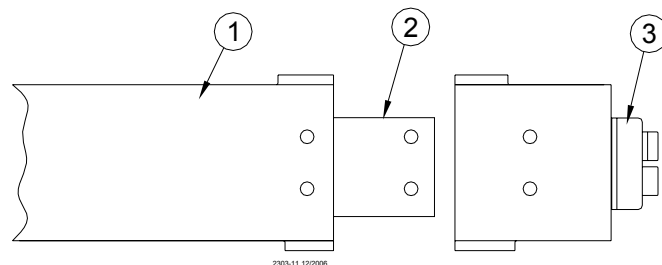

2883 Power Winch

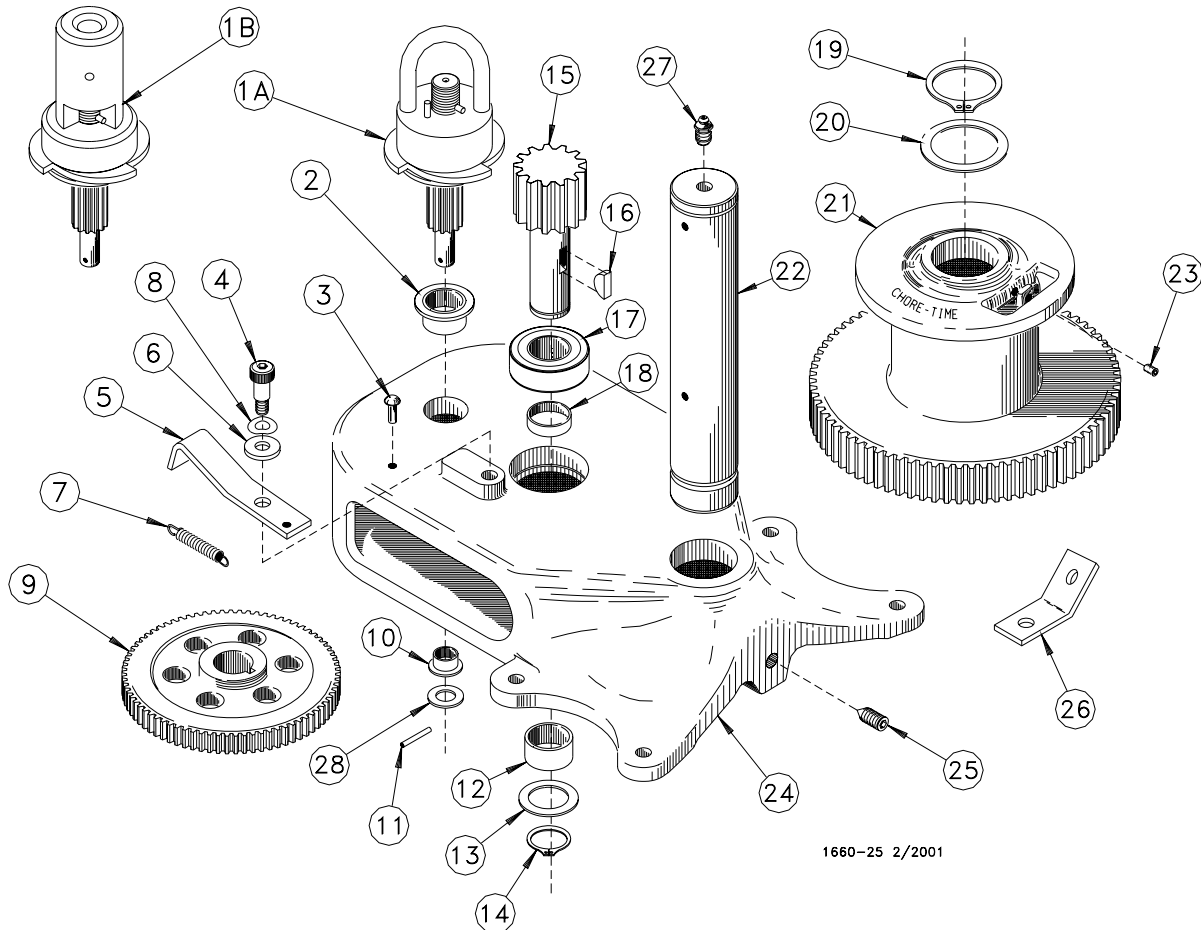

1660-25 2/2001

Item	Description	Part No.
1	Input Shaft Assembly	
1A	Manual	42665
1B	Electric	42666
2	Flange Bushing	2967-2
3	Drive Stud	4128-1
4	Shoulder Bolt	4022-2
5	Pawl	6672
6	5/16" Flat Washer	2255-44
7	Spring	1543
8	Spring Washer	4023
9	Intermediate Gear	2890
10	Flange Bushing	3252
11	Spirol Pin	2960-3
12	Bushing	2967-4
13	Washer	2955-1
14	Retaining Ring	2958-1

Item	Description	Part No.
15	Drive Pinion	2962
16	Woodruff Key	2959
17	1" Bearing	4937
18	Spacer	4936
19	Retaining Ring	3556
20	Washer	2955-2
21	Winch Drum	3723
22	Drum Shaft	3637
23	Setscrew	603
24	Winch Frame	3719
25	Setscrew	3727
26	Cable Hook	2985
27	Grease Zerk	24499
28	Washer	2499

Miscellaneous Suspension Components

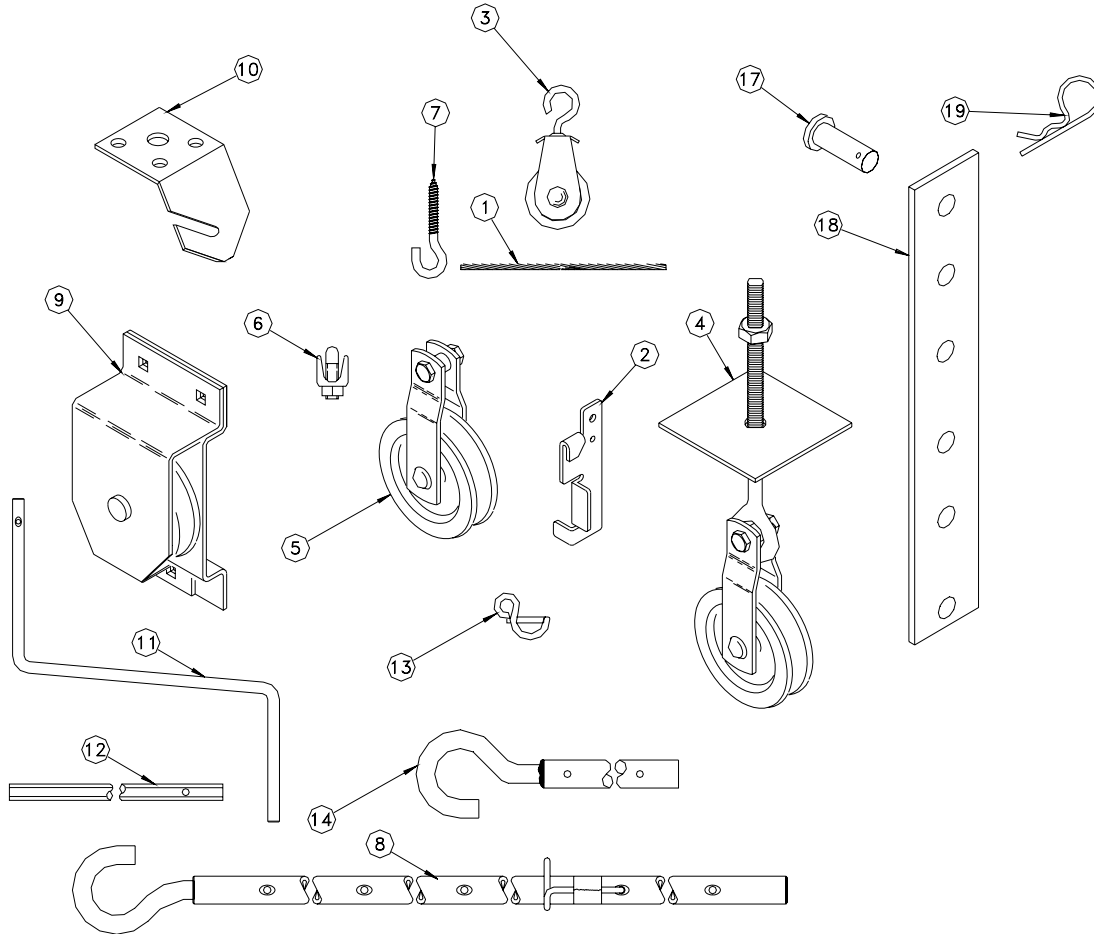

MF1814-2B 1/05

Item	Description	Part No.
1	3/16" Cable	1213
2	Cable Lock	14337
3	Pulley with Swivel	3004
4	Heavy Duty Pulley Assembly	2014
5	Oulley	2500
6	3/16" Cable Clamp	732
7	Screw Hook	2041
8	Extendable Drive Tube	47637
9	Pulley Assembly	28429
10	Ceiling Hook	28550
11	Handle Shank	3148
12	Drill Adapter Shaft	2886
13	Winch Handle Pin	3761
14	Winch Drive Tube (4')	2884-1
	Winch Drive Tube (8')	2884-2
	Winch Drive Tube (2')	2884-4
15	---	---
16	---	---
17	Clevis Pin, 5/16" x 1"	2797-1
18	Adjustable Bracket	2706
19	Hair Pin	2664
--	Full Line Suspension Kit	7948

Item 11 and 13 may be ordered as a kit under Part No. 2885
 Item 12 and 13 may be ordered as a kit under Part No. 2886
 Item 11, 13 and 8 may be ordered a a kit under Part No. 47683

MODEL ATF™ Pan Assemblies

MODEL ATF™ Pan Assembly
No Swing Down
Plastic Pan
Plastic Feed Cone

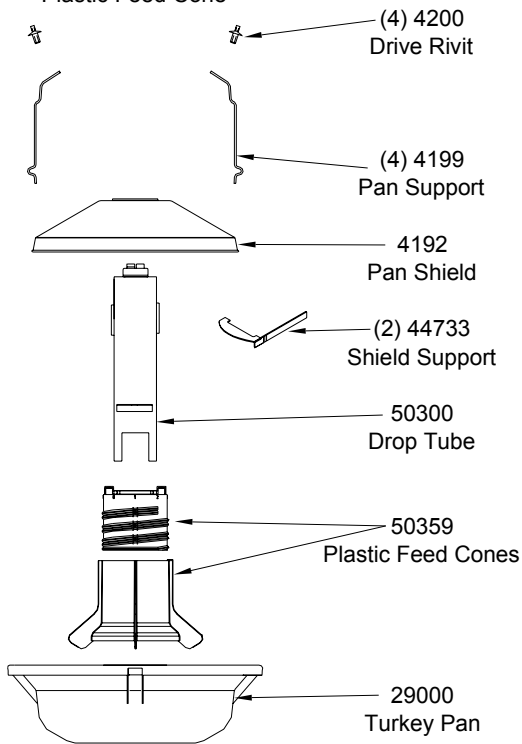

MODEL ATF™ Pan Assembly
With Swing Down
Plastic Pan
Plastic Feed Cone

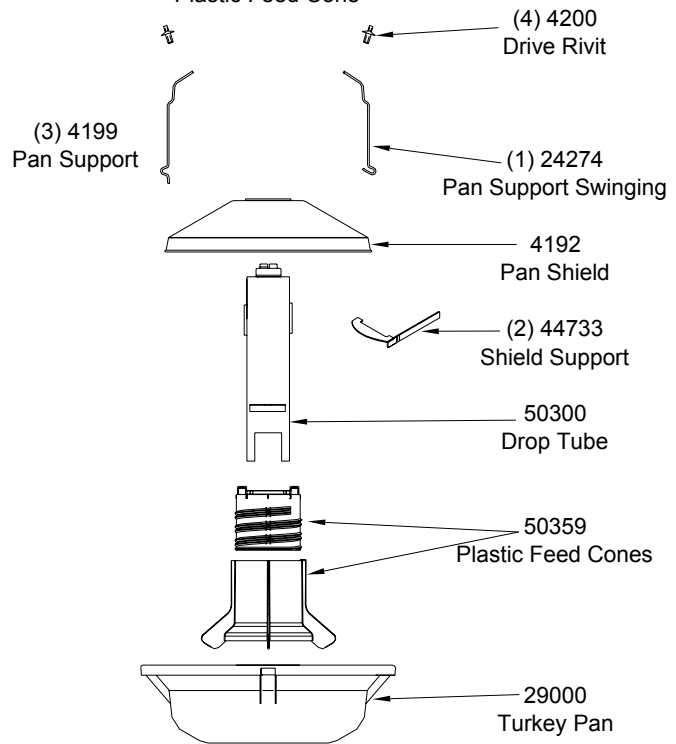

MODEL ATF™ Pan Assembly
No Swing Down
Metal Pan
Plastic Feed Cone

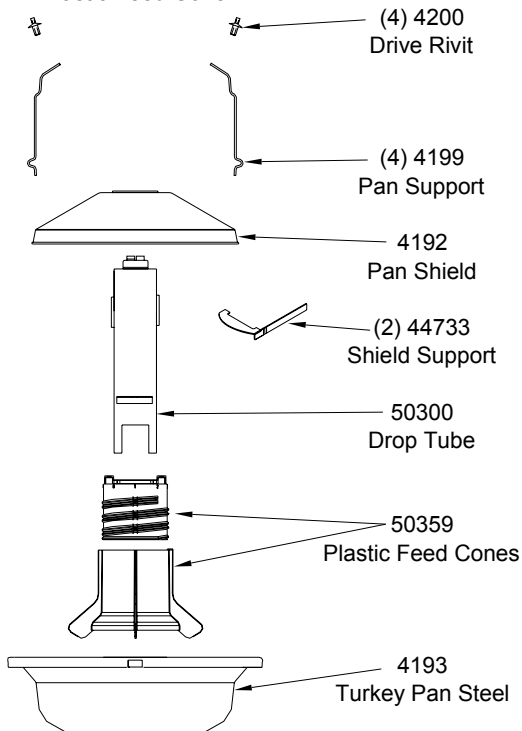

MODEL ATF™ Pan Assembly
With Swing Down
Metal Pan
Plastic Feed Cone

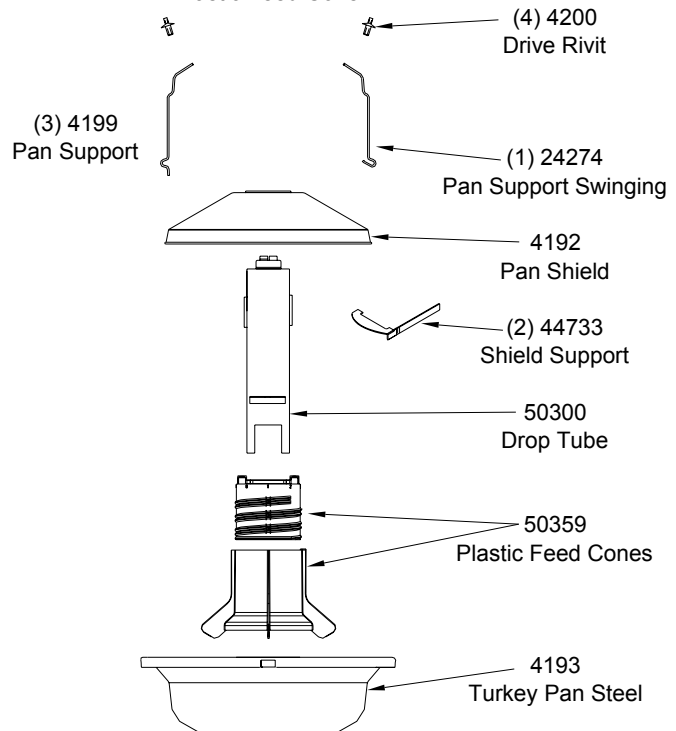

MODEL ATF™ PLUS Pan Assemblies

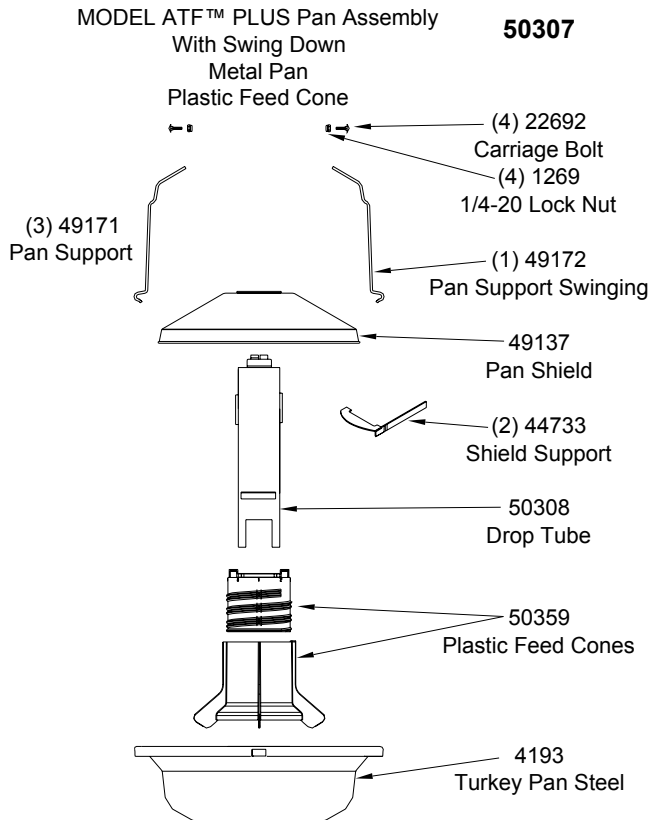
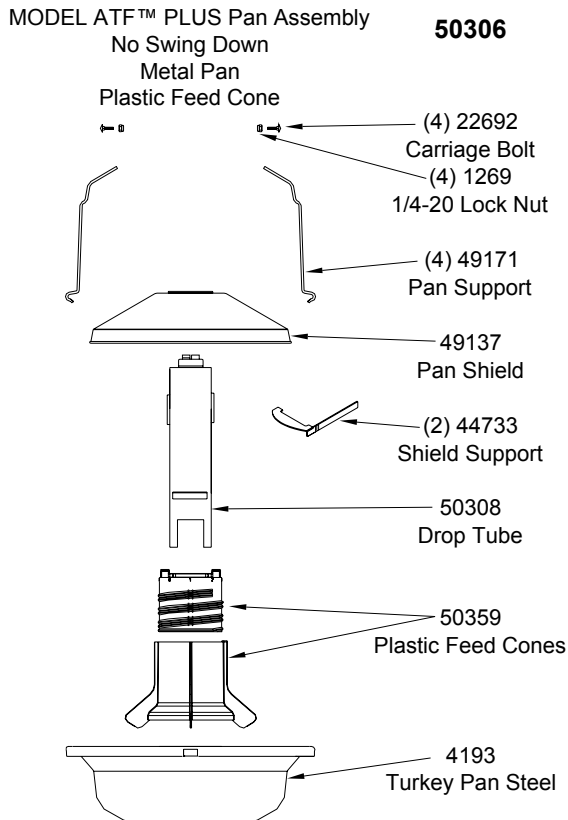
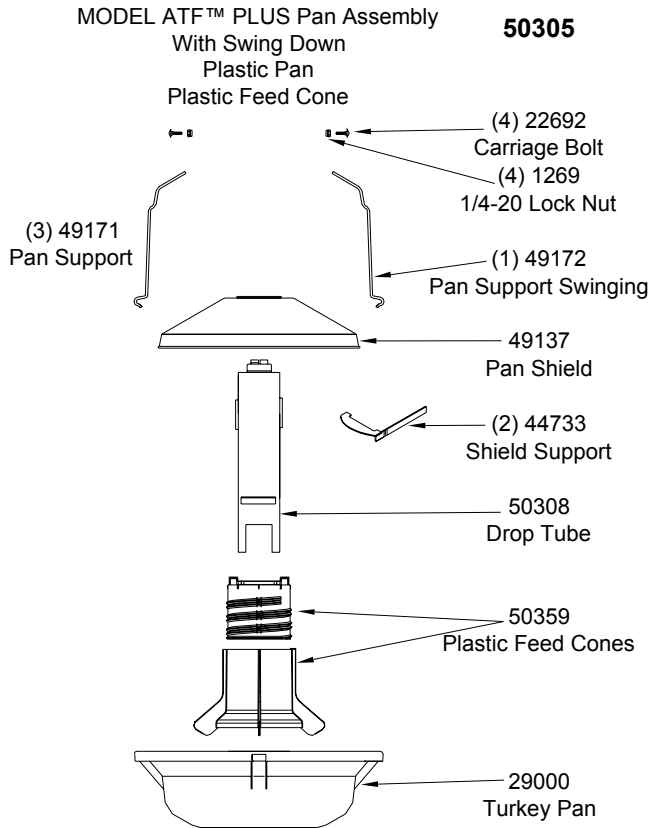
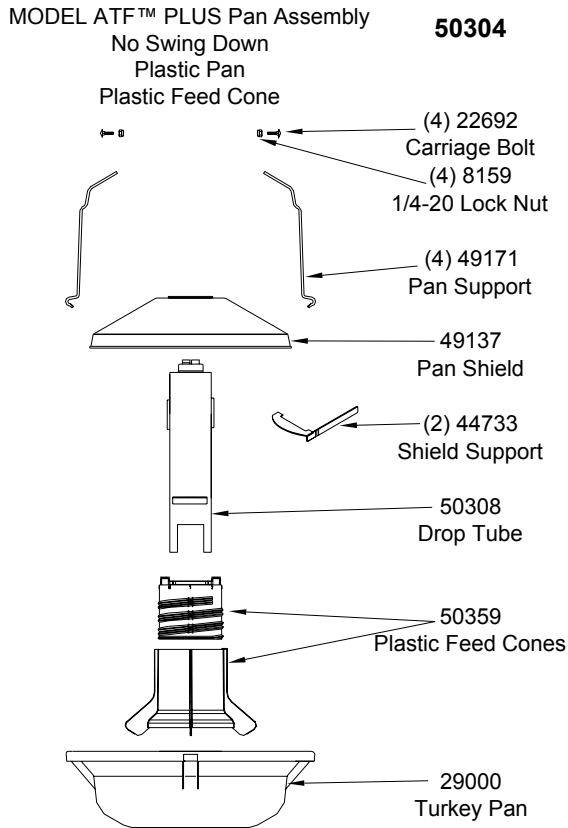

2305-ATF PLUS Pan Assemblies

Optional Parts

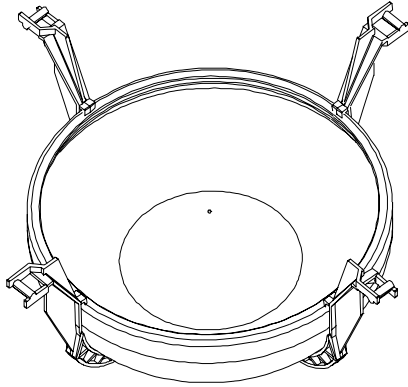

THE H2 PLUS PAN ADAPTER IS MADE UP OF TWO PARTS PLUS H2 PAN

PART NO. 41474 INCLUDES 41100-1 & -2
TOP HALF PART NO. 41100-1
BOTTOM HALF PART NO. 41100-2
H2 PLUS PAN PART NO. 24901
PART NO. 41475 INCLUDES 41100-1 & -2
PLUS 24901 PAN

APPLICATION: THIS PRODUCT WILL BE USED WHERE THE DAY OLD TURKEYS WILL BE STARTED ON THE ADULT TURKEY FEEDER FOR THE FIRST 5 WEEKS. THEN THE PAN ASSEMBLY WILL BE REMOVED AN THE ADULT PAN INSTALLED.

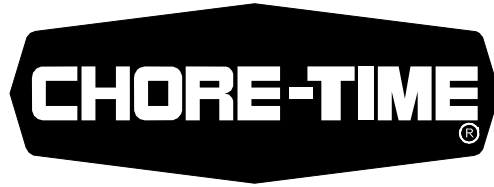

MADE TO WORK.

BUILT TO LAST.®

Contact your nearby Chore-Time distributor or representative for additional parts and information.

**CTB Inc.
P.O. Box 2000 • Milford, Indiana 46542-2000 • U.S.A.
Phone (574) 658-4101 • Fax (877) 730-8825
E-mail: poultry@choretime.com • Internet: www.choretime.com**

Printed in the U.S.A.