

Vike Straight Line Feeding System for Aviary



For additional parts and information, contact your nearest Chore-Time distributor or representative.
Find your nearest distributor at: www.choretime.com/contacts

CTB, Inc.
PO Box 2000
Milford, Indiana 46542-2000 USA
Phone (574) 658-4101
Email: choretime@choretime.com
Internet: www.choretime.com

Installation and Operators Manual

Installation and Operators Manual

Contents

Topic	Page
Chore Time Limited Warranty	3
Introduction.	4
Safety	5
Safety–Alert Symbol	5
Understanding Signal Words.	5
Follow Safety Instructions.	5
Decal Descriptions.	5
Installation.	6
Power Unit End.	6
Installing Power Unit and Components.	7
Trough and Perch Installation	8
Trough and Perch Connections	10
Intake End (Boot)	11
Boot end Assembly	12
Auger Installation	13
Auger Brazing/Filing	15
Cover Plate Installation.	15
Wiring	16
Wiring Diagrams	16
Operation.	18
Running the system.	18
Parts Listing	20
Vike Adapt Straight Line Feeder Package (57476-X)	20
Boot Assembly (35727)	22
Power Unit Assembly	23
Troubleshooting	24
Motor will not run	24
Motor runs but Feed does not get delivered.	24
Fill system motor overloads	24

Chore Time Limited Warranty

Chore-Time Group, a division of CTB, Inc. (“Chore-Time”) warrants the new CHORE-TIME Straight Line Feeding Parts manufactured by Chore-Time to be free from defects in material or workmanship under normal usage and conditions, for One (1) year from the date of installation by the original purchaser (“Warranty”). Chore-Time provides for an extension of the aforementioned Warranty period (“Extended Warranty Period”) with respect to certain Product parts (“Component Part”) as set forth in the table below. If such a defect is determined by Chore-Time to exist within the applicable period, Chore-Time will, at its option, (a) repair the Product or Component Part free of charge, F.O.B. the factory of manufacture or (b) replace the Product or Component Part free of charge, F.O.B. the factory of manufacture. This Warranty is not transferable, and applies only to the original purchaser of the Product.

Component Part	Extended Warranty Period
RXL Fan (except motors and bearings)	Three (3) Years
TURBO® Fan (except motors and bearings)	Three (3) Years
TURBO® Fan fiberglass housing, polyethylene cone, and cast aluminum blade.	Lifetime of Product
TURBO® fan motor and bearings.	Two (2) Years
Chore-Time® Poultry Feeder Pan	Three (3) Years
Chore-Time® Rotating Centerless Augers (except where used in applications involving high moisture feed stuffs exceeding 17%)	Ten (10) Years
Chore-Time Steel Auger Tubes	Ten (10) Years
ULTRAFLO® Breeder Feeding System auger and feed trough.	Five (5) Years
ULTRAPAN® Feeding System augers .	Five (5) Years

CONDITIONS AND LIMITATIONS

THIS WARRANTY CONSTITUTES CHORE-TIME’S ENTIRE AND SOLE WARRANTY AND CHORE-TIME EXPRESSLY DISCLAIMS ANY AND ALL OTHER WARRANTIES, INCLUDING, BUT NOT LIMITED TO, EXPRESS AND IMPLIED WARRANTIES, INCLUDING, WITHOUT LIMITATION, WARRANTIES AS TO MERCHANTABILITY OR FITNESS FOR PARTICULAR PURPOSES. CHORE-TIME shall not be liable for any direct, indirect, incidental, consequential or special damages which any purchaser may suffer or claim to suffer as a result of any defect in the Product. Consequential or Special Damages as used herein include, but are not limited to, lost or damaged products or goods, costs of transportation, lost sales, lost orders, lost income, increased overhead, labor and incidental costs, and operational inefficiencies. *Some jurisdictions prohibit limitations on implied warranties and/or the exclusion or limitation of such damages, so these limitations and exclusions may not apply to you. This warranty gives the original purchaser specific legal rights. You may also have other rights based upon your specific jurisdiction.*

Compliance with federal, state and local rules which apply to the location, installation and use of the Product are the responsibility of the original purchaser, and CHORE-TIME shall not be liable for any damages which may result from non-compliance with such rules.

The following circumstances shall render this Warranty void:

- Modifications made to the Product not specifically delineated in the Product manual.
- Product not installed and/or operated in accordance with the instructions published by the CHORE-TIME.
- All components of the Product are not original equipment supplied by CHORE-TIME.
- Product was not purchased from and/or installed by a CHORE-TIME authorized distributor or certified representative.
- Product experienced malfunction or failure resulting from misuse, abuse, mismanagement, negligence, alteration, accident, or lack of proper maintenance, or from lightning strikes, electrical power surges or interruption of electricity.
- Product experienced corrosion, material deterioration and/or equipment malfunction caused by or consistent with the application of chemicals, minerals, sediments or other foreign elements.
- Product was used for any purpose other than for the care of poultry and livestock.

The Warranty and Extended Warranty may only be modified in writing by an officer of CHORE-TIME. CHORE-TIME shall have no obligation or responsibility for any representations or warranties made by or on behalf of any distributor, dealer, agent or certified representative.

Effective: **April, 2014**

Introduction

Chore-Time has designed the Vike Straight Line Feeding System to be installed in Vike Aviary Systems to feed Poultry Livestock.

The system is designed to feed 4-6 birds per foot (25 birds per meter) of trough. See **page 18** for Fill times.

The Auger serves as a stirring device as it delivers feed.

Chore-Time recommends using a Chore-Tronics[®] 3 Breeder Edition Control to manage run times. See **Chore-Time Manual MT2484** for Installing and operating the Chore-Tronics[®] 3 Breeder Edition Control.

Safety

Caution, Warning, and Danger Decals have been placed on the equipment to warn of potentially dangerous situations. Care should be taken to keep this information intact and easy to read at all times. Replace missing or damaged safety decals immediately.

Safety–Alert Symbol



This is a safety–alert symbol. When you see this symbol on your equipment, be alert to the potential for personal injury. This equipment is designed to be installed and operated as safely as possible...however, hazards do exist.

Understanding Signal Words

Signal words are used in conjunction with the safety–alert symbol to identify the severity of the warning.



DANGER—Indicates an imminently hazardous situation which, if not avoided, **WILL** result in death or serious injury.



WARNING—Indicates a potentially hazardous situation which, if not avoided, **COULD** result in death or serious injury.



CAUTION—Indicates a hazardous situation which, if not avoided, **MAY** result in minor or moderate injury.

Follow Safety Instructions

Carefully read all safety messages in this manual and on your equipment safety signs. Follow recommended precautions and safe operating practices.

Keep safety signs in good condition. Replace missing or damaged safety signs.

Decal Descriptions

DANGER: Moving Auger

This decal is placed on the End Cap Weldment and Clean-out cover. Severe personal injury will result, if the electrical power is not disconnected, prior to servicing the equipment.



DANGER: Electrical Hazard

- Disconnect electrical power before inspecting or servicing equipment unless maintenance instructions specifically state otherwise.
- Ground all electrical equipment for safety.
- All electrical wiring must be done by a qualified electrician in accordance with local and national electric codes.
- Ground all non-current carrying metal parts to guard against electrical shock.
- Electrical disconnects and over current protection are not supplied with the equipment.

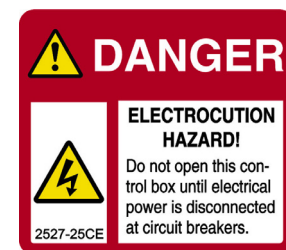

DANGER: Springing Auger

Use caution when working with Auger. Springing Auger may cause personal injury.

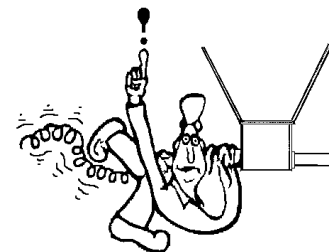

Attention: Read the Manual

See the manual for detailed installation instructions.



Installation

Power Unit End

The Power Unit is installed at the Manure Belt Drive End of the System.

1. Assemble Perch Supports **as shown**. A Second Screw will be installed later when Trough is installed.
2. Install the Straight Line Motor Support (**Item 10**) at the end of the system using M8 x 16 Taptites (**Item 4**).
3. Install Perch Supports at each Top Cross Beam (**Item 7**) with M8 x 16 Taptites (**Item 4**) **as shown**.
4. Slide the first Perch Tube through the Motor Support (**Item 10**). As you Slide the Perch Tube through the Perch Supports, hang an extra Perch Support **Assembly** on the Perch Tube, centered between the Top Cross Beams.
5. Slide the Perch Tube all the way in, leaving just enough room to install two Self Tapping Screws (**Item 6**). These will keep the Perch Tubes from coming out.

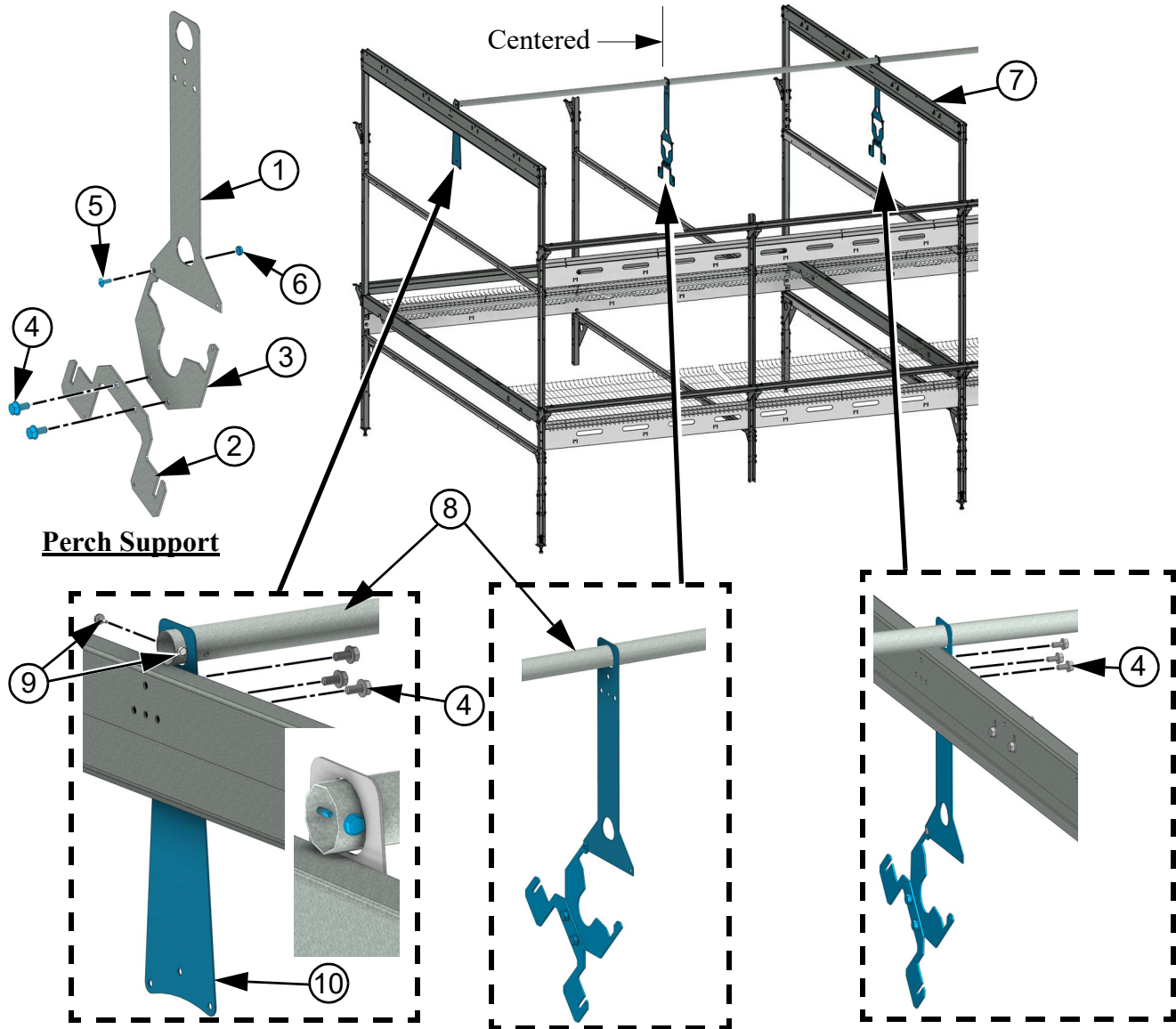

Item	Description	Part No
1	Straight Line Motor Support	57385
2	Suspension Plate	210107
3	Feeder Hanger	57388
4	M8 x 16 Taptite	201047
5	10-24 x .5 Machine Screw	1795

Item	Description	Part No
6	10-24 Kepnut	27725
7	Top Cross Beam	56601
8	Perch Tube	208000
9	#10 x 1/2" Self Tapping Screw	3037
10	Straight Line Motor Support	57132

Figure 1. Assembly at Power Unit End

Installing Power Unit and Components

Control Unit Assembly

1. Fasten a Switch Assembly (Item 2) to the Control Body (Item 1) using #10 x .5 Screws (Item 3). (See Figure 2.)
2. Loosen the Switch Cover Screws (Item 4) to allow for the install of the Control Switch Cover (Item 5).
3. Install the Tube Anchor End (Item 6) and Control Switch Cover using four 1/4-20 Bolts and Nuts (Items 7 and 8)
4. Re-tighten the Switch Cover Screws
5. Install a Straight Line Perch Bracket (Item 9) with 1/4-20 Neck Bolts and Flange Nuts (Items 7 and 8).
6. Install a Strt. Line Under Motor Plate (Item 10) with 1/4-20 x .63 Bolts and Flange Nuts (Items 11 and 8).

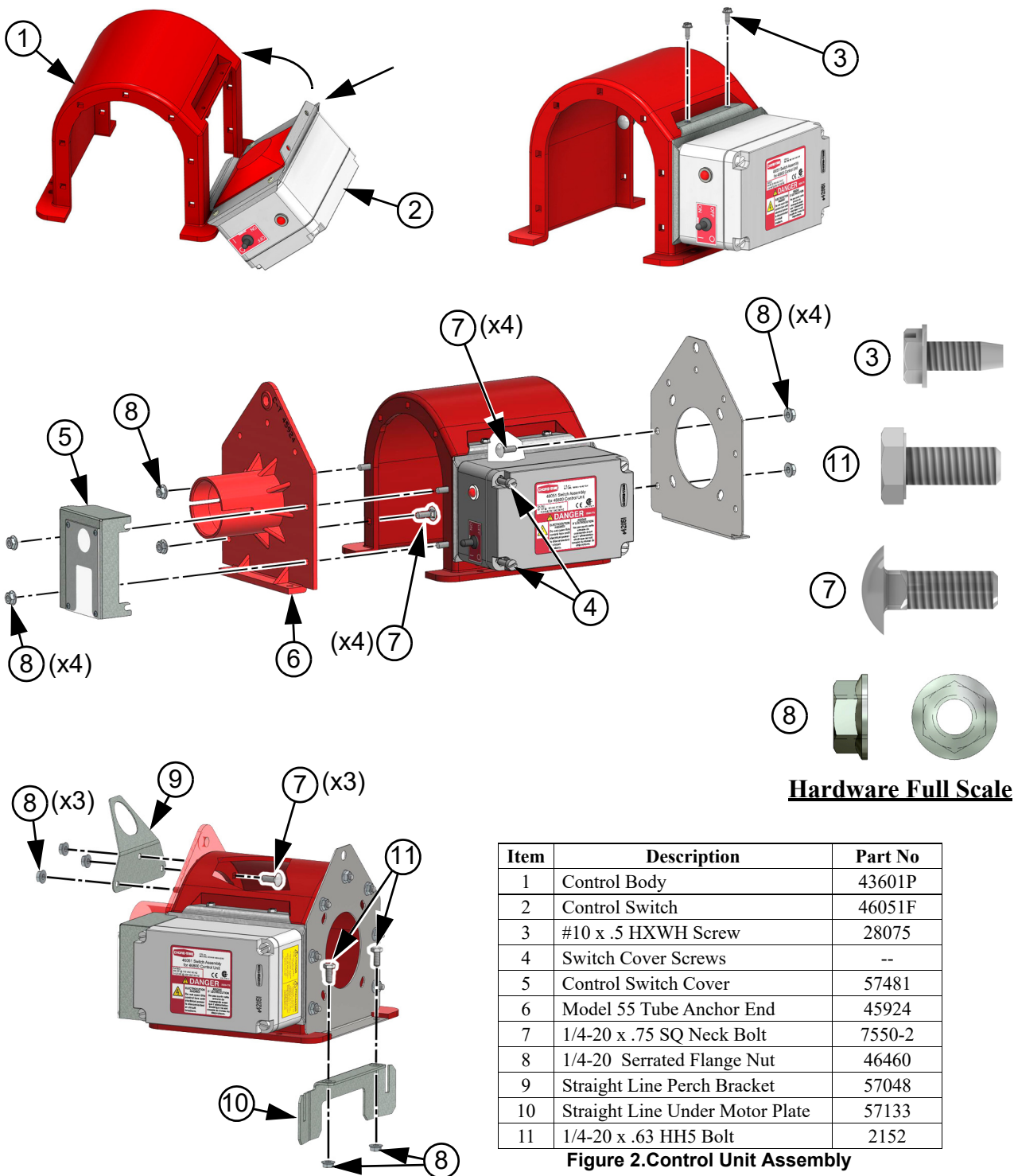

Control Unit Installation

1. Fasten the Control Unit Assembly to the Straight Line Motor Support (**Item 1**) using #10 x .5 Screws (**Item 3**) as shown.

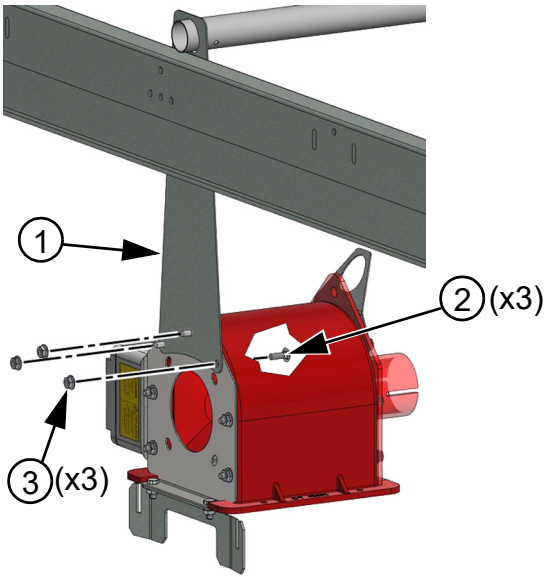

Item	Description	Part No
1	Straight Line Motor Support	57385
2	#10 x .5 HXWH Screw	28075
3	1/4-20 Serrated Flange Nut	46460

Figure 3. Control Unit Installation

Trough and Perch Installation

Perch Tube

1. Insert the first Perch Tube (**Item 1**) into the holes in the Feeder Hanger Assembly (assembled in Figure 1. on page 6) and through the Perch Bracket (**Item 3**) as shown.
2. Install two #10 x 1/2" Self Tapping Screws (**Item 4**) in the end of the Perch Tube.

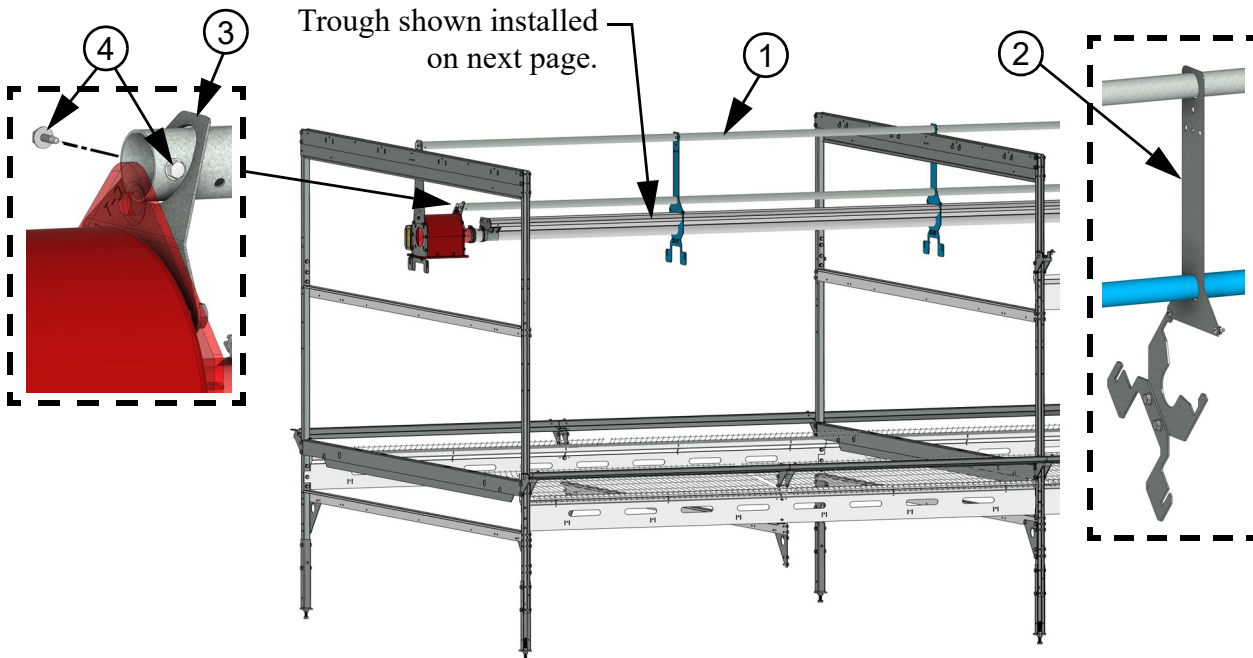

Item	Description	Part No
1	[6m] 236.2" Perch Tube	208000
2	Feeder Hanger (assembled earlier)	--
3	Perch Bracket	57048
4	#10 x 1/2" Self Tapping Screw	3037

Figure 4. Perch Tube Installation

Trough End Cap Assembly

1. Install an End Cap Assembly (**Item 1**) on the Non-Belled end of a Trough section as shown.
2. Use Holes in the End Cap Assembly to drill two 1/4" [6.3 mm] Holes on each side of the Trough.
3. Fasten with 10-24 Machine Screws (**Item 2**) and Nuts (**Item 3**) as shown.

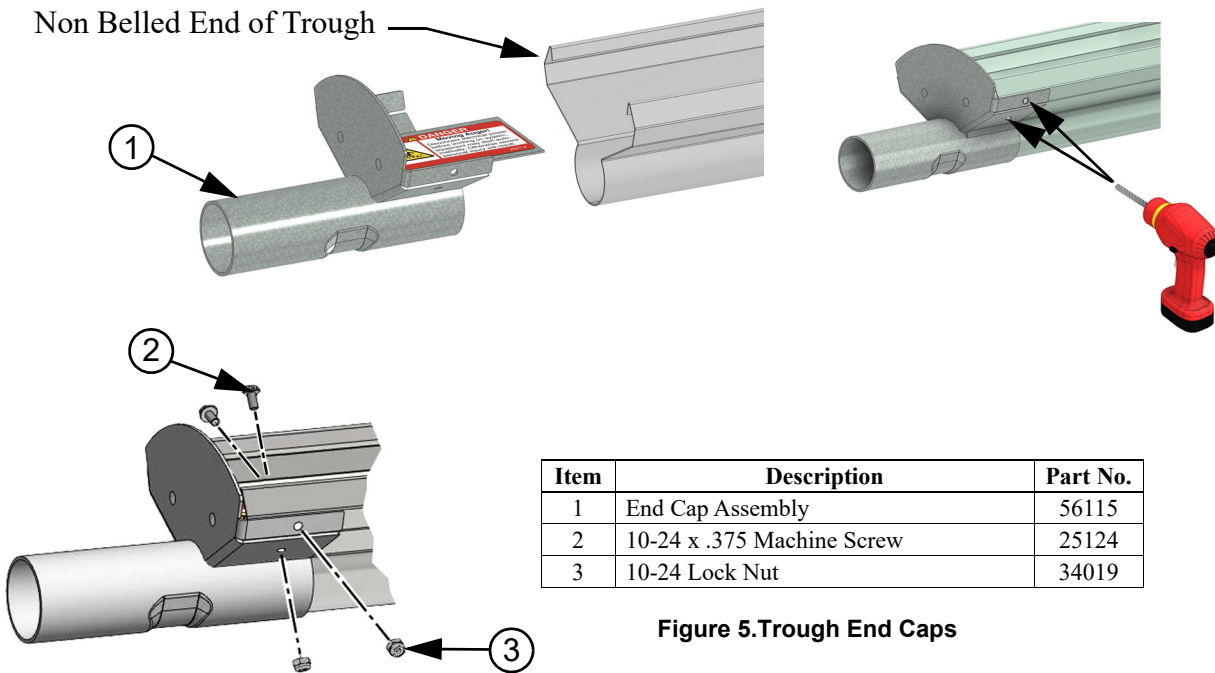
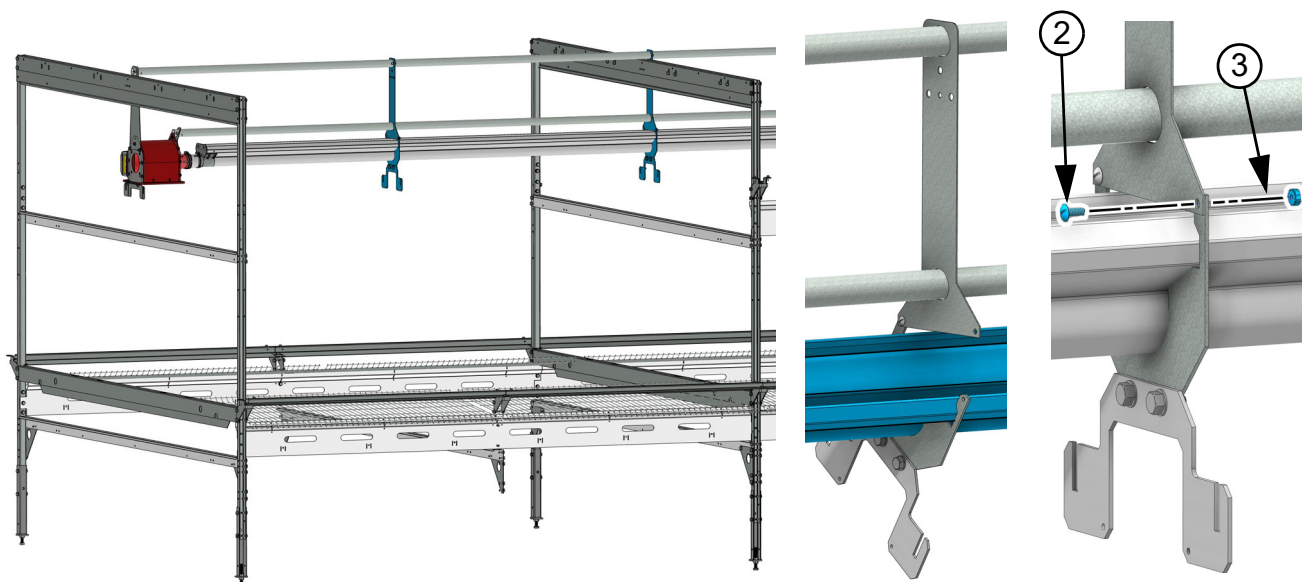

Figure 5. Trough End Caps

Trough Installation

1. Set the first Trough section in the Trough Hangers as shown.
2. Rotate the Trough Hangers up and install 10-24 Machine Screws and Lock Nuts (**Items 2 and 3**).



Item	Description	Part No.
1	End Cap Assembly	56115
2	10-24 x .375 Machine Screw	25124
3	10-24 Lock Nut	34019

Figure 6. Installing first Trough section

Connecting Trough to End Control

1. Connect the 1st Trough section to the End Control using a Tube Connector (**Item 1**) and two Adjustable Clamps (**Item 2**) as shown.

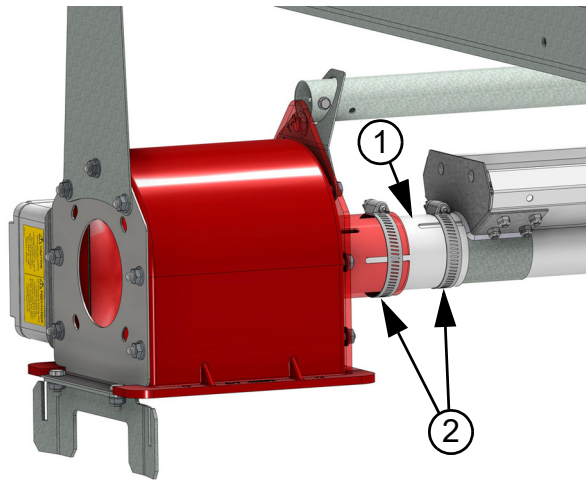

Item	Description	Part No.
1	Tube Connector	29691
2	Heavy Duty Adjustable Clamp	47652-1

Figure 7. Connecting Trough to Power Unit

Trough and Perch Connections

Trough Connections

1. Install Trough Sections as shown in (Figure 6) with the Non-Bell end of each Trough toward the Control Unit end of the System.
2. Use 10-24 Screws (**Item 3**) and 10-24 Nylon Hx Nuts (**Item 2**) to attach the Troughs together as shown.

Important! The Feed should always flow toward the Non-Belled end of the Trough!

Perch Tube Connections

Connect Perch Tubes together with M6 4.8 x 19 Hex Screws (**Item 5**) as shown.

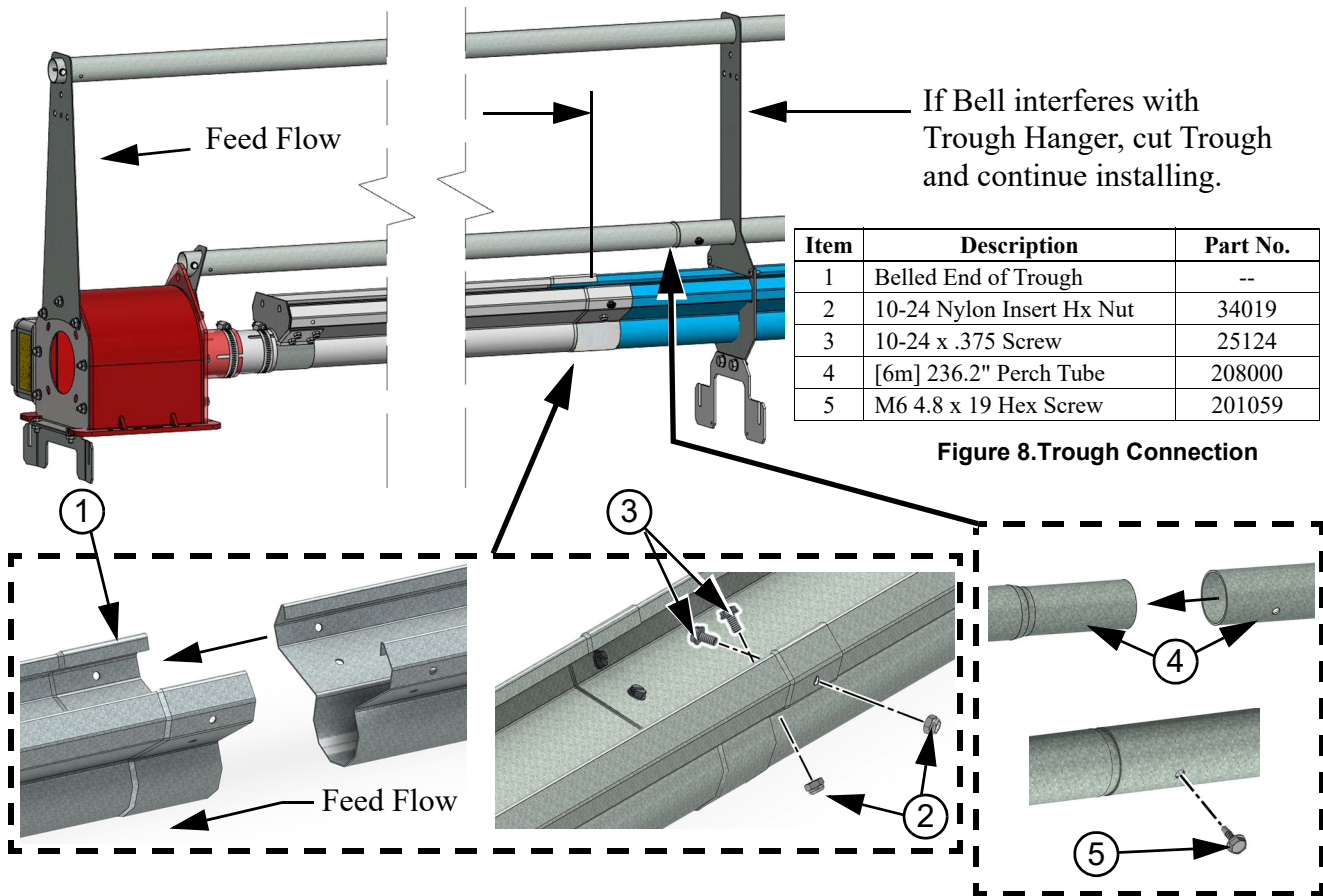

Figure 8. Trough Connection

Intake End (Boot)

1. Assemble the parts to make up the Perch Support to be used at the Intake end **as shown**.

Note: Perch Tubes (**Item 9**) at the end of the system should have a minimum of 3/4" [1.9cm] overhang **as shown**. For ease of assembly you may want to cut off the Perch Tubes before fastening the Perch Support.

2. Fasten the Intake End Perch Support and the Boot Support Hook (**Item 7**) to the Cross Beam at the end of the system with M8 x 16 Taptites (**Item 4**).

3. Install two M6 4.8 x 19 Hex Screws (**Item 8**) in the Perch Tubes to keep them from sliding out **as shown**.

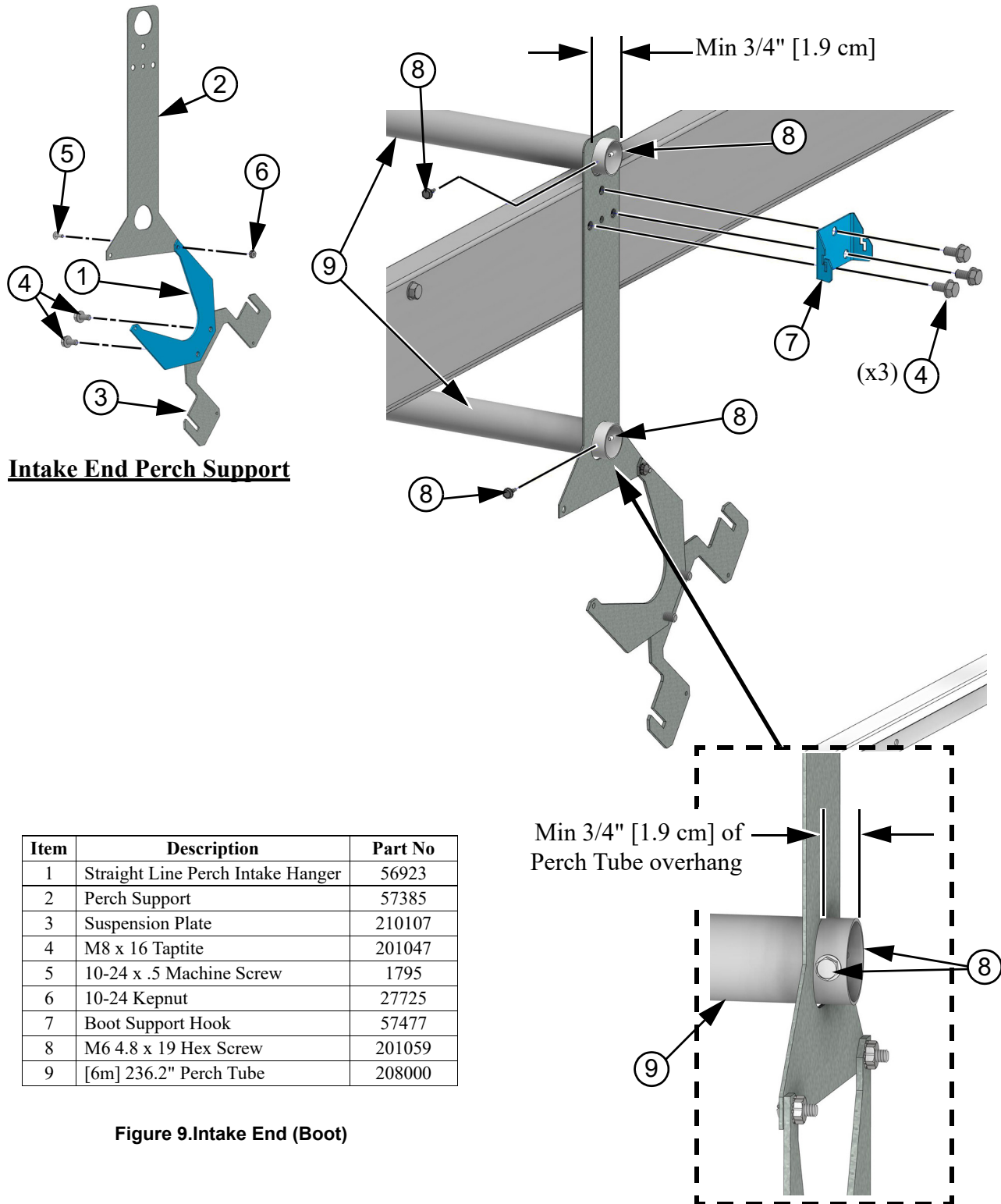

Figure 9.Intake End (Boot)

Boot end Assembly

1. Cut the last section of Trough (See Figure 10.)
2. Install a Trough End Cap the same as was done in Figure 5. on page 9.
3. Install the Transfer Cover (Item 1) using 1/4-20 Eye Bolts, Hex Nuts (Item 3), and Washers (Item 4).
4. Install the Boot using a Model 55 Tube Clamp (Item 5), Tube Connector (Item 6), and an Adjustable Clamp (Item 7).

Note: Some effort will be required to push the Boot onto the Tube Connector (Item 6).

5. Install a Chain (Item 8), and S-hooks (Item 9) to support the Boot Assembly.

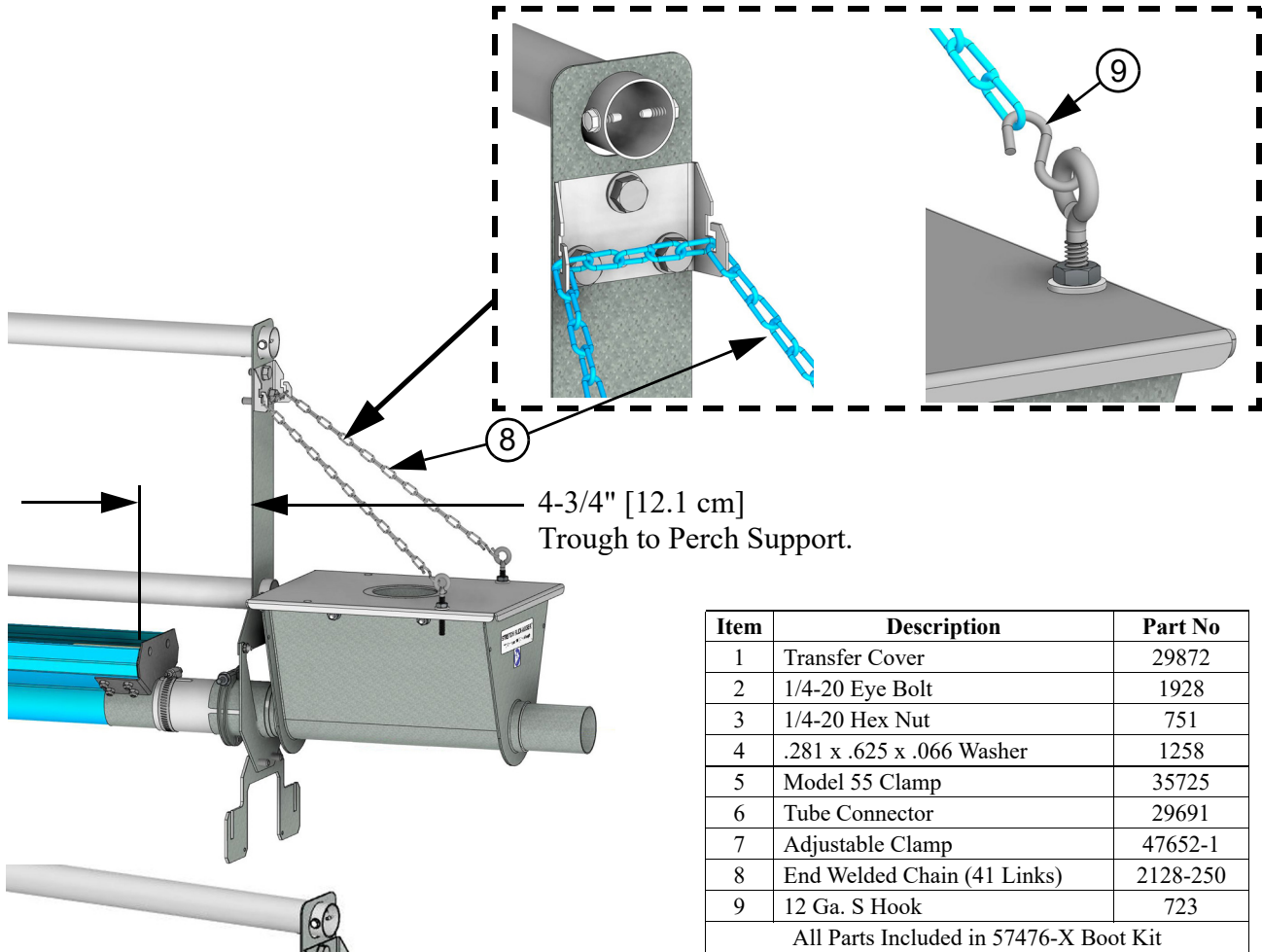
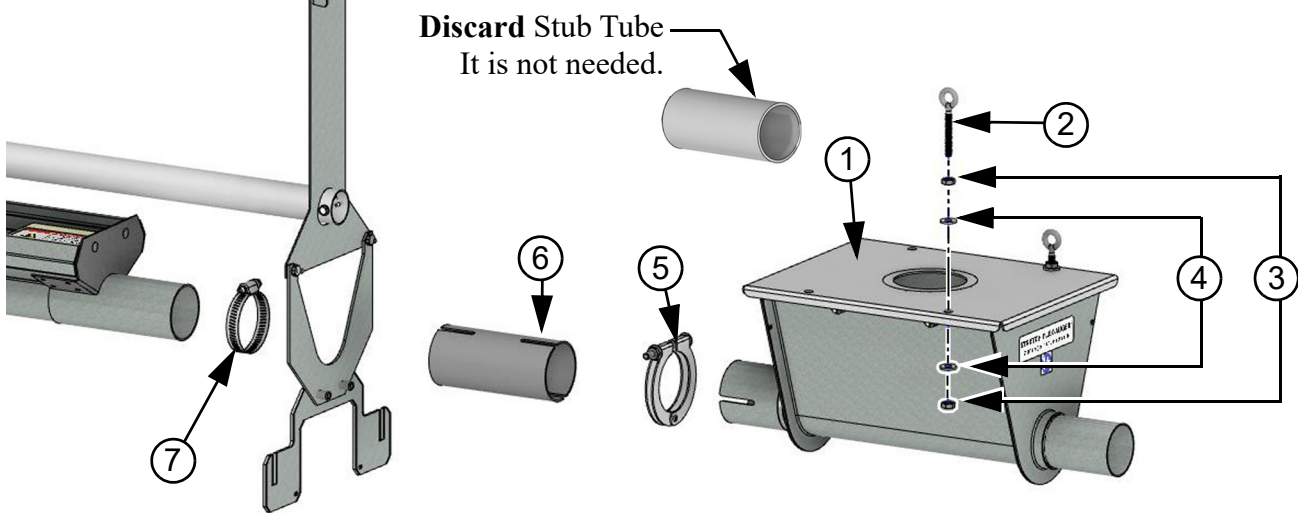

Figure 10.Boot End Assembly



Auger Installation

Use extreme caution when working with the auger. The auger is under tension and may spring causing injury. Always wear protective clothing and protective glasses when working with the auger.

Use extreme caution when pushing the auger into the auger tubes. Keep your hands away from the end of the auger tube to avoid injury.

Handle the FLEX-AUGER carefully. Dropping the rolls of auger may cause the auger to kink. Do not install an auger that has a sharp kink in it. The kink will cause the auger to wear a hole in the tube at that spot. If the kink cannot be straightened with pliers, the kink must be cut out and the auger brazed back together. Refer to “Auger Brazing/ Filing” on page 15 in this manual for the correct brazing procedure.



Use caution when working with the Auger--springing auger may cause personal injury.

1. Beginning at the boot, push the Auger into the Auger Tube through the rear of the boot until the Auger reaches the control unit end.

Use extreme caution when pushing the auger into the auger tubes. Keep your hands away from the end of the auger tube to avoid injury.

2. Attach the Auger to the Driver as shown.
3. Attach the Power Unit to the Control Unit with 5/16-18 x .63 Bolts (Item 4).

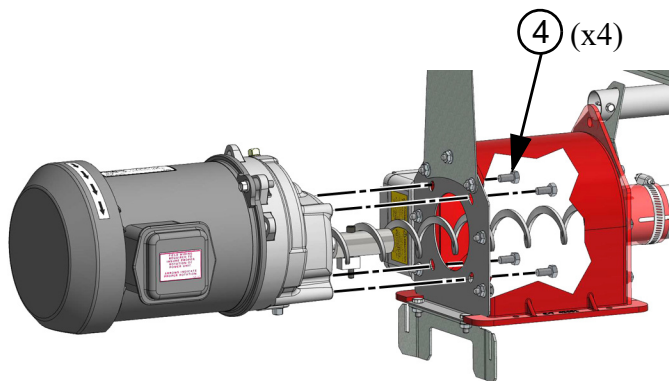
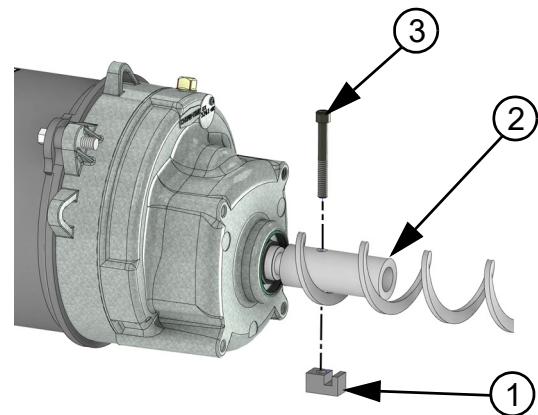
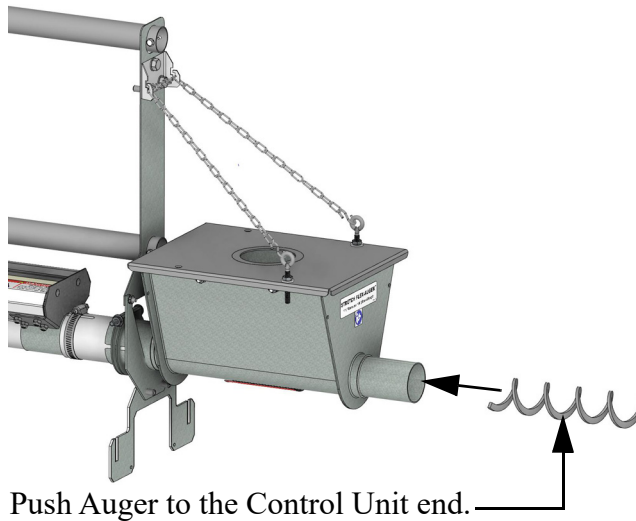
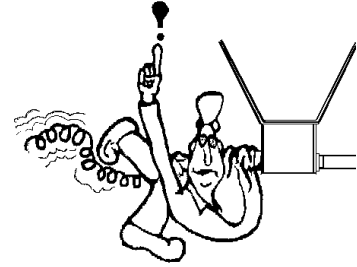

Item	Description	Part No
1	Driver Block	4642
2	Driver Tube	30932
3	1/4-20 x 2 Socket Hd. Cap Screw	5083-4
4	5/16-18 x .63 Bolt	4412-1

Figure 11.Auger Installation

Auger Stretch



Use caution when working with the Auger--springing auger may cause personal injury.

Stretch the Auger 2 inches (50 mm) for every 50 feet (15.2 m) of length.
 Example: For a 150 ft. (45 m) system the Auger should be cut 6 inches (150 mm) shorter than its natural length. Measure the amount of stretch from the rear edge of the boot and cut the Auger at that point. (See Figure 12.)

1. Pull on the loose end of the Auger at the boot once or twice until it begins to stretch, then release it slowly. This will bring the auger to its natural length.
2. Measure and mark the Auger at the point where it is to be cut (See Auger Stretch above).
3. Pull the Auger until the Mark is out far enough to allow for the Anchor and Bearing Assembly (Item 1) to be installed and use Vice Grips to hold the Auger in place as shown.
4. Cut the Auger at the Mark.
5. Insert the Auger over the Anchor and feed it through the Auger Clamp Pin (Item 2) until the Auger touches the Washer on the Anchor and Bearing Assembly. Tighten the Auger Clamp Screw (Item 3) to 10-12 ft.-lbs. **Note:** Over tightening the Set Screw may cause damage to the Auger Clamp.

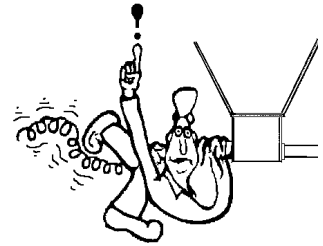

Use caution when working with the Auger--springing auger may cause personal injury

6. Carefully remove the Vice Grips to allow the Auger to snap into place.
7. Install the Stub Tube (Item 4), Cap (Item 5), and Tube Clamp (Item 6) as shown.

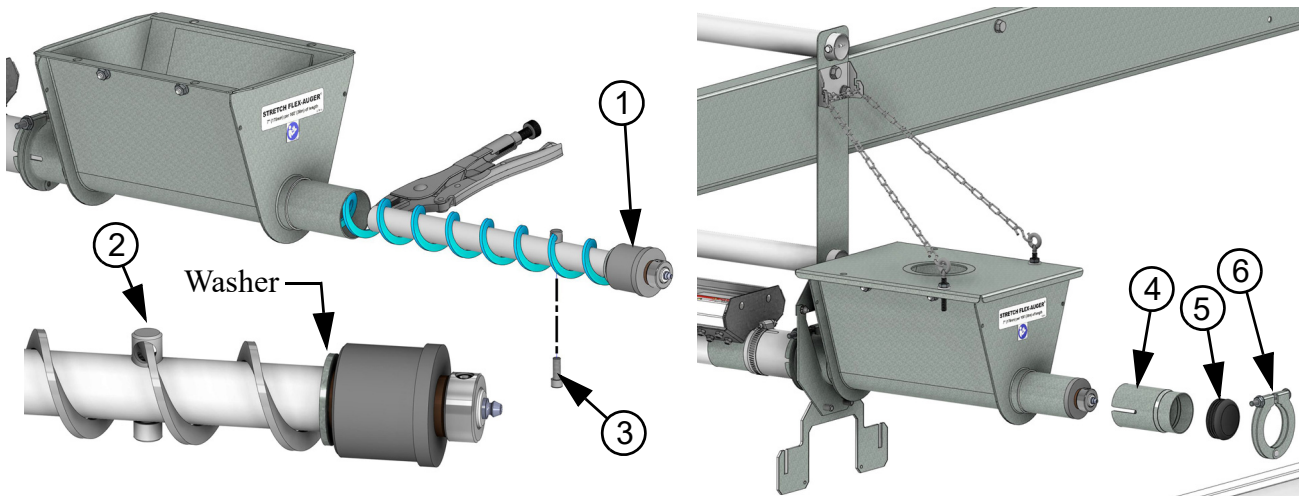
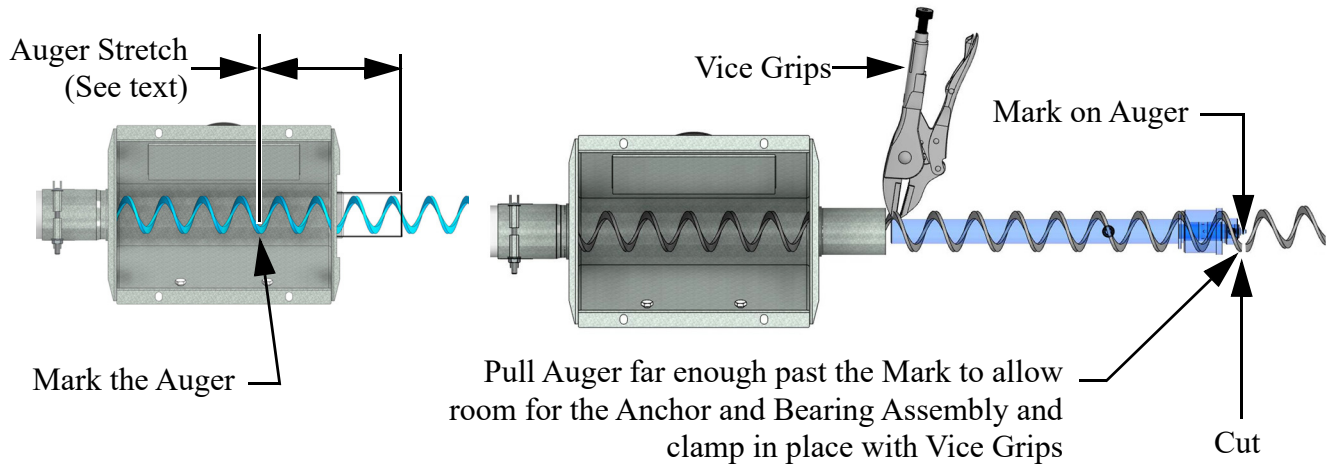

Item	Description	Part No
1	Anchor and Bearing Assembly	39408
2	Auger Clamp Pin	39205
3	5/16-18 x .875 Auger Clamp Screw	6850-6

Item	Description	Part No
4	2.016 x 3.435 Stub Tube	4163
5	2.0" Cap	29523
6	2.0" Tube Clamp	29520-1

Figure 12. Auger Installation (Stretch)

Auger Brazing/Filing

If the auger needs to be spliced or lengthened, locate the brazed joint closer to the power unit to minimize feed flow restriction in the line.

To align the auger for brazing, lay it in angle iron and clamp securely.

Rotate the auger to allow both the inside and outside edges of the augers to be brazed.

Butt the ends of the auger against each other. **DO NOT SCREW ONE AUGER INSIDE THE OTHER**--This restricts the feed flow.

(**Figure 13**) and the associated chart specify how far to lap the augers.

A bronze, flux-coated rod is recommended. The joint should be well filled and smooth so that it does not wear against the tube. Allow the joint to air cool.

File the auger edges, as shown in (**Figure 13**), to avoid damage to the auger tubes. Also, file off any brazing that extended beyond the outside radius of the auger flightings.

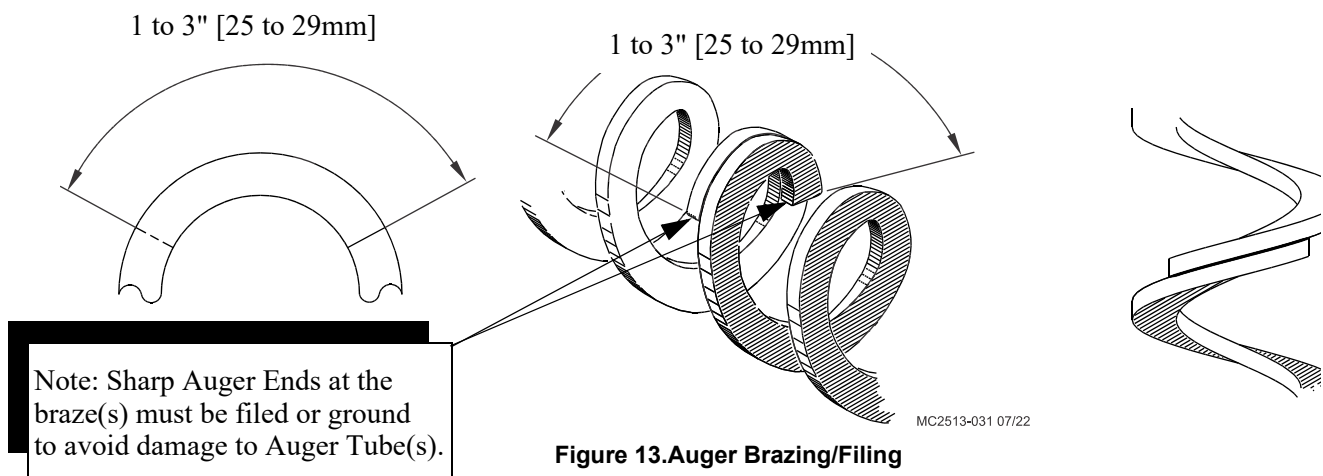

Cover Plate Installation

The cover plate is installed after installation of the auger in the tube see figure 14..

To install the cover plate:

1. Loosen 5/16-18 Lock Nuts (**Item 1**) to end of studs
2. Start lower side of Cover Plate (**Item 2**) in Boot opening.
3. Slide the Cover Plate up as far as possible so that Plate catches top of Boot opening.
4. Hold the Cover securely while tightening the 5/16-18 Lock Nuts.

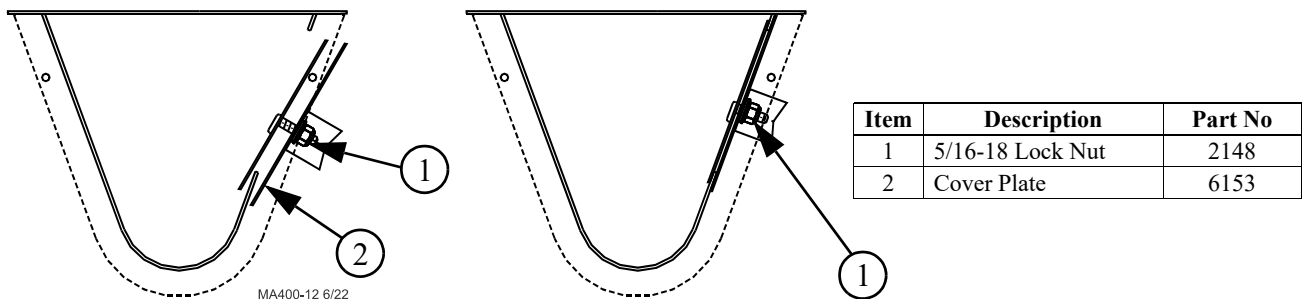
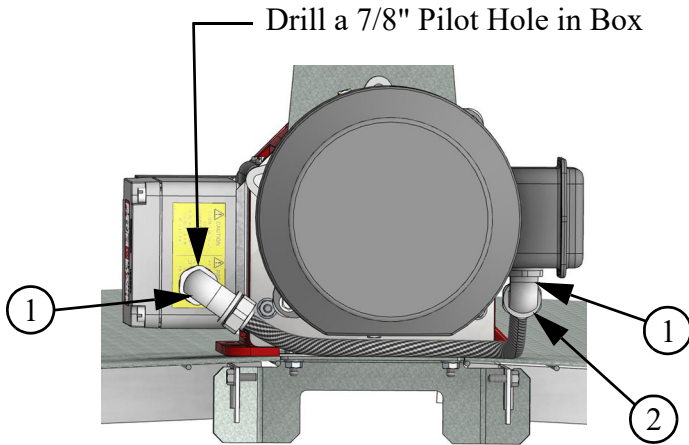

Figure 14. Cover Plate Installation

Wiring

1. Drill a hole in the end of the Switch Box as shown.
2. Install 90° Connectors (**Item 1**).
3. Install Flex Conduit.



Item	Description	Part No
1	90° Connector	23810
2	Flex Conduit	26982-10

Wiring Diagrams

3259-98 Power Unit (5977 Motor)

Wire as shown for Clock-wise rotation.

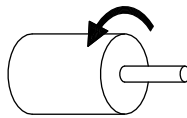

P1 Purple — Orange

T4 Yellow —

J10 Black —

For Counter Clock-wise rotation switch the Red and Black Wires.

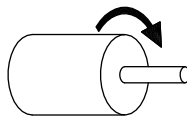

T3 Orange — Orange

T8 Red —

Green Ground Screw

3259-134 Power Unit (28031 Motor) Wiring

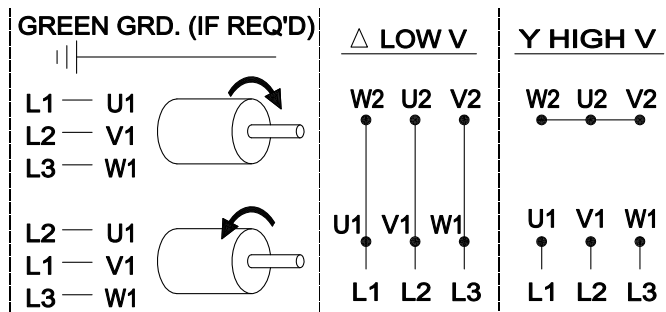

3259-145 (5703 Motor)

There are two Manufacturers of the 5703 Motor. Wiring diagrams shown for both Manufacturers

Nidec Motor Wiring

Nidec / US Motor

Wired as shown for
Clock-wise rotation

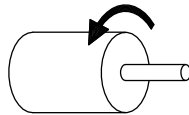

For Counter-clockwise
rotation switch the Yellow
and Blue Wires

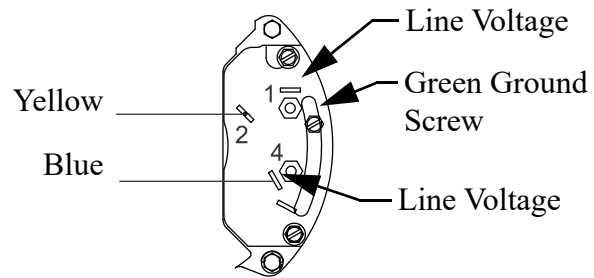
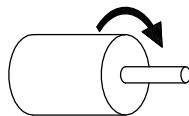

Regal Beloit / Marathon Wiring

Wired as shown for
Clock-wise rotation

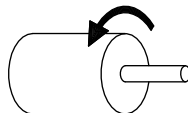

For Counter-clockwise
rotation switch the Yellow
and Blue Wires

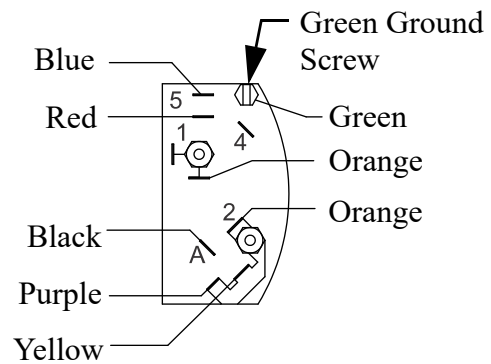
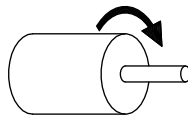

Operation

Running the system

The Straight Line Feeding system can be operated manually or using a Timer. Chore-Time recommends connecting to a Chore-Tronics Control. If using a Chore-Tronics Control see the **Chore-Tronics® 3 manual MT2398** on the Chore-Time website.

1. Most applications will only require running the feeding system once a day corresponding with the normal loop fill system run time.
2. You want to avoid dropping excess feed at the end of the system. Use the Timer to adjust the run times so that there is just enough feed to get to the end of the line without dumping extra feed.
3. The chart below shows the amount of time that it takes to fill the line with feed based on which Power Unit the System is using.

Power Unit	Phase	Hertz	RPM	Time to fill (minutes)											
				100ft [45.7m]	150' [30.5m]	200' [70m]	250' [76.2m]	300' [91.4m]	350' [106.7m]	400' [121.9m]	450' [137.2m]	500' [152.4m]	550' [167.6m]	600' [182.9m]	650' [198.1m]
3259-98	1	50	348	1.97	2.96	3.94	4.93	5.91	6.9	7.88	8.87	9.85	10.8	11.8	12.8
3259-134	3	50	290	2.36	3.55	4.73	5.91	7.09	8.28	9.46	10.6	11.8	13	14.2	15.4
3259-134	3	60	348	1.97	2.96	3.94	4.93	5.91	6.9	7.88	8.87	9.85	10.8	11.8	12.8
3259-145	1	60	216	3.17	4.76	6.35	7.94	9.52	11.1	12.7	14.3	15.9	17.5	19	20.6

This page left blank intentionally....

Parts Listing

Vike Adapt Straight Line Feeder Package (57476-X)

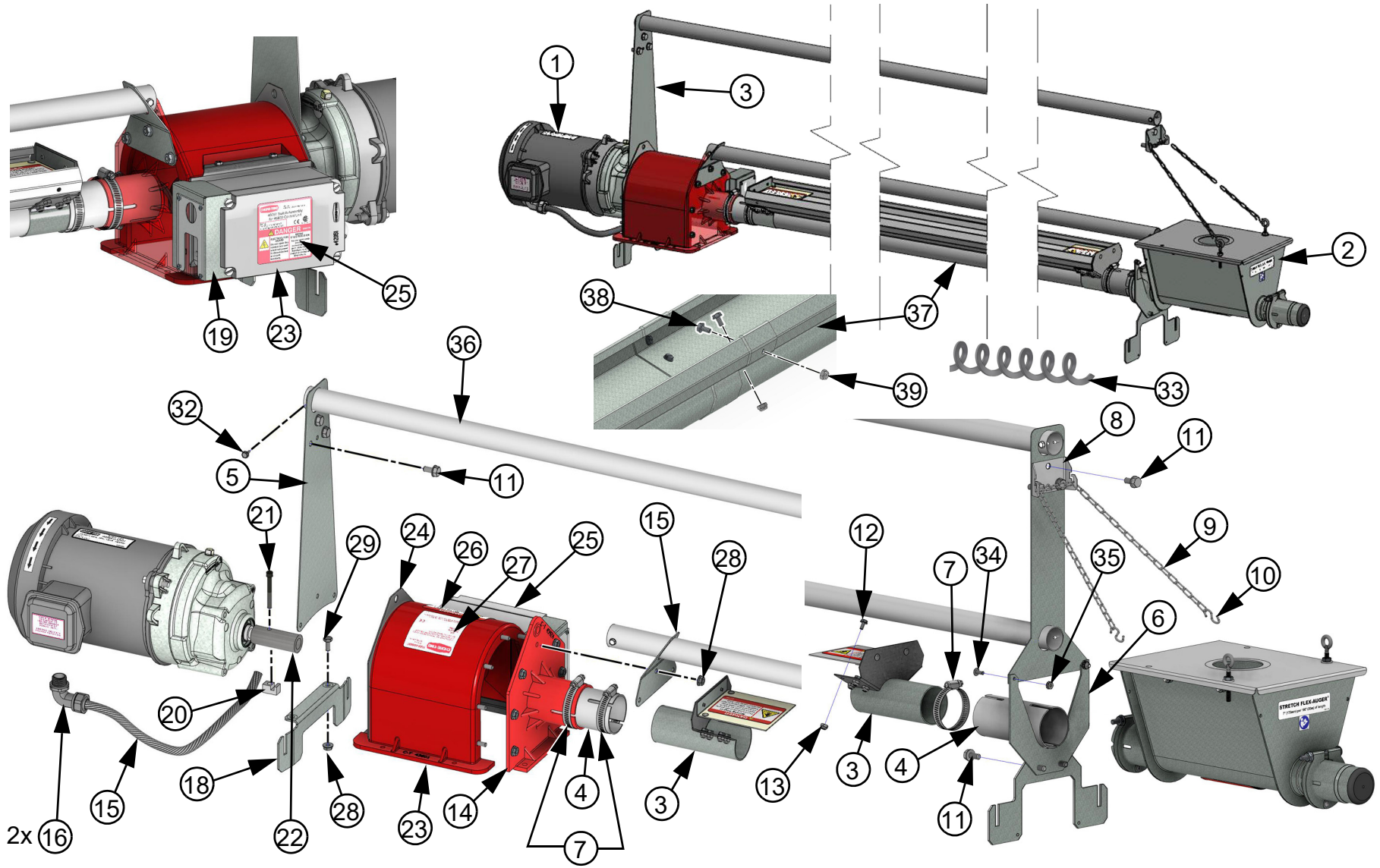

MC2513A

57476-X Vike Adapt Straight Line Feeder Package				
Item	Description	57476-1	57476-2	57476-3
		Part No.		
1	.5HP 348RPM 1PH50HZ 220/240V Power Unit	3259-98	--	--
	.5HP 348RPM 3PH 60HZ 220/380V Power Unit	--	3259-134	--
	.5HP 216RPM 1PH 60HZ 230V Power Unit	--	--	3259-145
2 ¹	Single Transfer Boot Assembly	35727	35727	35727
3	End Cap Assembly	25169	25169	25169
4	Tube Connector	29691	29691	29691
5	Vike Adapt Straight Line Support (At Motor)	57132	57132	57132
6	Vike Adapt Straight Line Intake Hanger	56923	56923	56923
7	Heavy Duty Adjustable Clamp	47652-1	47652-1	47652-1
8*	Vike Adapt Straight Line Boot Support Hook	57477	57477	57477
9*	End Welded Chain	2128-250	2128-250	2128-250
10*	12 Ga. x 1.13 S Hook	723	723	723
11*	M8 x 16 Taptite	201047	201047	201047
12**	10-24 x .375 HXWH Screw	25124	25124	25124
13**	10-24 Hx Lock Nut	34019	34019	34019
¹ See 35727 Boot Assembly				
*Included in 57478 Boot Support Hardware Package				
**Included in 27424 Parts Hardware Kit				

47870-13 Vike Adapt Straight Line Feeder Package		
Item	Description	Part No.
14	55 Tube Anchor End	45924
15	1/2 x 22 Flex Conduit	26982-10
16	1/2" Liquid Tight Connector	23810
17	Vike Adapt Straight Line Perch Bracket (At Motor)	57048
18	Vike Adapt Straight Line Under Motor Plate	57133
19	Vike Adapt Straight Line Control Switch Cover	57481
20**	Driver Block	4642
21**	.25 x 20 x 2 SKTH CP Screw	5083-4
22**	.875 x 2.75 Driver Tube	30932
**Included in 30931 Driver Parts Package See "Boot Assembly (35727)" on page 22.		

47869-1 Control Unit Package		
Item	Description	Part No.
23	Flex Auger Control Body	43601P
24	Gearhead End Plate	43596
25	Flex Auger Control Switch	46051F
26	Danger Moving Auger Decal	2527-9
27	Patent Flex Auger Decal	2529-15
28***	1/4-20 Hx Flange Nut	46460
29***	1/4-20 x .75 RHSQNK Bolt	7550-2
30***	1/4-20 x .63 HH5 Bolt	2152
31***	#10 x .5 HXWH Screw	28075
***In 56562 Hardware Package		

Miscellaneous Parts		
Item	Description	Part No.
32	10-16 x .5 Self Drilling Screw	3037
33*	1.75 O.D. Auger	25058F
34	10-24 x .5 Machine Screw	1795
35	10-24 Kepnut	27725
36	19'8-1/4" [6 meter] Perch Tube	208000
37**	Trough	14159-3
38**	10-24 x 3/8 Hx Hd Machine Screw	29697
39**	10-24 Crown Lock Nut	29519
*Auger available in 10' lengths from 50' to 400ft max. Ex: 25058F-80 is 80' long.		
**Trough and Trough Hardware included in 29694 Kit		

Boot Assembly (35727)

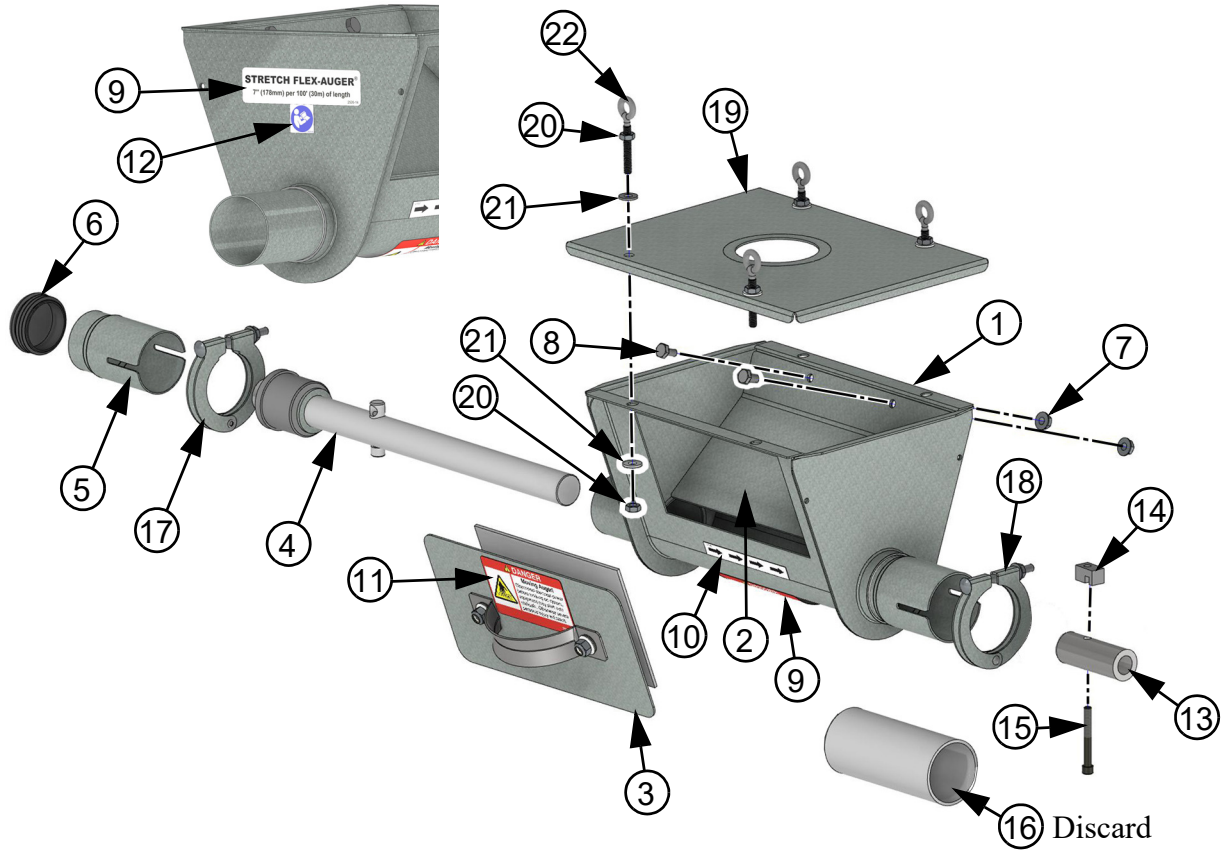

35727 Boot Assembly		
Item	Description	Part No.
1	Weldment Boot Body	35532F
2	Single Baffle	35646
3	Clean-Out Cover Assembly	6197
4	Anchor and Bearing Assembly	39408
5	2.016 x 3.435 Stub Tube	4163
6	2.0 O.D. Cap	29523
7	1/4-20 Serrated Flange Nut	46460
8	1/4-20 x .5 HH5 Bolt	1487
9	Stretch Auger Decal	2526-14
10	Posiflo Input Shaft Decal	2526-76
11	Danger Moving Auger Decal	2527-9
12	Read the Manual Decal	2527-91
13*	Drive Tube	30932
14*	Block Driver	4642
15*	.25 x 20 x 2 SKTH CP Screw	5083-4
16	5" Stub Tube (Discard) Not needed.	8555
17	2" Clamp Assembly	29520-1
18	Model 55 Clamp Assembly	35726-1
19	Transfer Cover	29872
20**	1/4-20 HX Nut	751
21**	.281 x .625 x .066 Washer	1258
22**	1/4-20 x 1.625 Eye Bolt	1928
*In 30931 Driver Parts Package		
**Included in 39873 Parts Package		

Power Unit Assembly

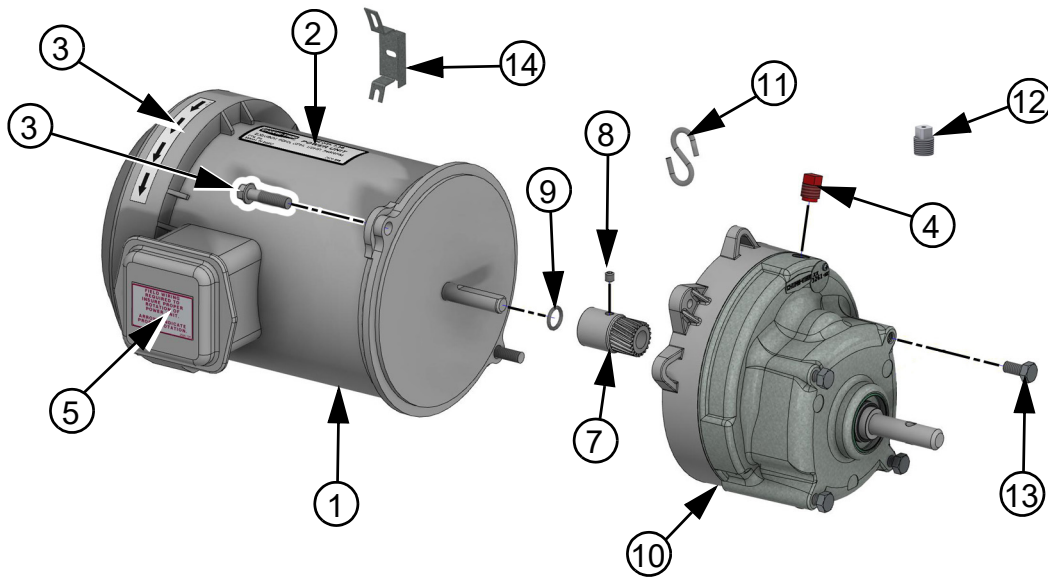

		Power Unit Assembly Part Numbers		
		3259-98 1/2HP, 1PH, 50Hz, 220/240V, 348 RPM	3259-134 1/2HP, 3PH, 60Hz, 220/380V, 348 RPM	3259-145 1/2HP, 1PH, 60Hz, 230V, 216 RPM
Item	Description	Part No.		
1	1/2 HP, 3PH, 60Hz, 220/380V Motor	--	28031EUR	--
	1/2 HP, 3PH, 50Hz, 220/240V Motor	5977	--	--
	1/2 HP, 1PH, 60Hz, 230V Motor	--	--	5703
2	Power Unit Decal	2529-312	2529-629	2529-719
3	5/16-18 x 1.25 Hx WH Screw	38163	38163	38163
4	Pipe Plug	3516	3516	3516
5	Field Wiring Decal	--	2526-195	--
6	Rotation Decal	--	2526-76	--
7	Pinion 348 RPM	5052	5052	--
	Pinion 216 RPM	--	--	3245
8	1-4-28 x .25 Set Screw	5362	5362	5929
9	O-Ring	3209	3209	3209
10	Gearhead Assembly	3261-11	3261-5	3261-1
11*	S-Hook	2805	2805	2805
12*	.25 Pipe Plug (Replaces Item 4)	3523	3523	3523
13*	5/16-18 x .63 Bolt	4412-1	4412-1	4412-1
14	Motor Shield	36513	--	36513

*Included in 50221-3 Hardware Package

Troubleshooting

DANGER: Moving Auger

This decal is placed on the End Cap Weldment and Clean-out cover. Severe personal injury will result, if the electrical power is not disconnected, prior to servicing the equipment.



DANGER: Electrical Hazard

- Disconnect electrical power before inspecting or servicing equipment unless maintenance instructions specifically state otherwise.
- Ground all electrical equipment for safety.
- All electrical wiring must be done by a qualified electrician in accordance with local and national electric codes.
- Ground all non-current carrying metal parts to guard against electrical shock.
- Electrical disconnects and over current protection are not supplied with the equipment.

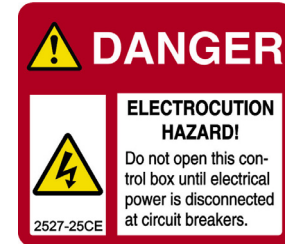

DANGER: Springing Auger

Use caution when working with Auger. Springing Auger may cause personal injury.

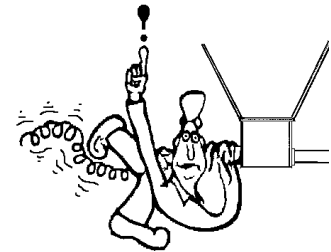

Motor will not run

Action: Check Wiring and Power Supply. May want to remove the Power unit and test.

Motor runs but Feed does not get delivered.

If the Feeder fails to operate, check the auger for foreign objects, water, or feed bridging. Foreign objects in the auger will cause the auger to become wedged.

1.Foreign objects in Trough

Action: Remove the object from the Auger. Check to make sure the Auger was not damaged or distorted. Replace damaged section of Auger if needed.

2.Feed Building up (Bridging) in Trough

Action: Clean stuck feed out of the Trough where it is building up (Bridging). Check for objects in Trough.

3.Feed Building up (Bridging) at Control Unit

Action: Clean excess feed out of the red plastic End Control Body. There is a Pressure Switch in the Control body that shuts the system off in the event of feed build up.

4.Feed is building up at Boot

Action: Clean out excess or stuck feed in the Boot and around the Driver and Anchor.

Fill system motor overloads

Action: Clean out excess or stuck feed in the Boot and around the Driver and Anchor.

This page left blank intentionally.....

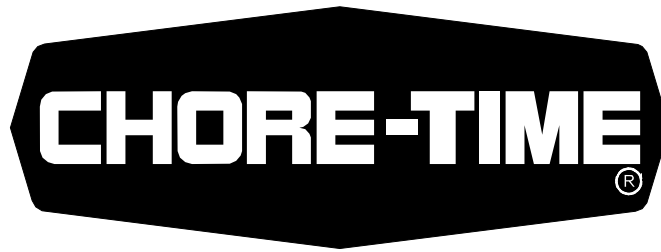

MADE TO WORK.

BUILT TO LAST.®

Revisions to this Manual

Page No.	Description of Change	ECO
	New Manual	36041

Contact your nearby Chore-Time distributor or representative for additional parts and information.

CTB, Inc.
PO Box 2000
Milford, Indiana 46542-2000 USA
Phone (574) 658-4101 Fax (877) 730-8825
Email: choretime@choretime.com
Internet: www.choretime.com