

ULTRAFLO[®] Dead End Fill System

Installation and Operators Manual

Installation and Operators Manual

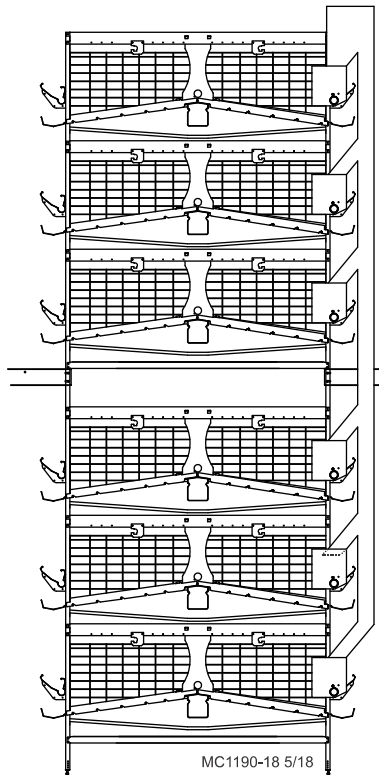

For additional parts and information, contact your nearest Chore-Time distributor or representative.
Find your nearest distributor at: www.choretime.com/contacts

Limited Warranty

LIMITED WARRANTY

Chore-Time Group, a division of CTB, Inc. (“Chore-Time”) warrants the new CHORE-TIME ULTRAFLO® components manufactured by Chore-Time to be free from defects in material or workmanship under normal usage and conditions, for One (1) year from the date of installation by the original purchaser (“Warranty”). Chore-Time provides for an extension of the aforementioned Warranty period (“Extended Warranty Period”) with respect to certain Product parts. If such a defect is determined by Chore-Time to exist within the applicable period, Chore-Time will, at its option, (a) repair the Product or Component Part free of charge, F.O.B. the factory of manufacture or (b) replace the Product or Component Part free of charge, F.O.B. the factory of manufacture. This Warranty is not transferable, and applies only to the original purchaser of the Product.

CONDITIONS AND LIMITATIONS

THIS WARRANTY CONSTITUTES CHORE-TIME’S ENTIRE AND SOLE WARRANTY AND CHORE-TIME EXPRESSLY DISCLAIMS ANY AND ALL OTHER WARRANTIES, INCLUDING, BUT NOT LIMITED TO, EXPRESS AND IMPLIED WARRANTIES, INCLUDING, WITHOUT LIMITATION, WARRANTIES AS TO MERCHANTABILITY OR FITNESS FOR PARTICULAR PURPOSES. CHORE-TIME shall not be liable for any direct, indirect, incidental, consequential or special damages which any purchaser may suffer or claim to suffer as a result of any defect in the Product. Consequential or Special Damages as used herein include, but are not limited to, lost or damaged products or goods, costs of transportation, lost sales, lost orders, lost income, increased overhead, labor and incidental costs, and operational inefficiencies. *Some jurisdictions prohibit limitations on implied warranties and/or the exclusion or limitation of such damages, so these limitations and exclusions may not apply to you. This warranty gives the original purchaser specific legal rights. You may also have other rights based upon your specific jurisdiction.*

Compliance with federal, state and local rules which apply to the location, installation and use of the Product are the responsibility of the original purchaser, and CHORE-TIME shall not be liable for any damages which may result from non-compliance with such rules.

The following circumstances shall render this Warranty void:

- Modifications made to the Product not specifically delineated in the Product manual.
- Product not installed and/or operated in accordance with the instructions published by the CHORE-TIME.
- All components of the Product are not original equipment supplied by CHORE-TIME.
- Product was not purchased from and/or installed by a CHORE-TIME authorized distributor or certified representative.
- Product experienced malfunction or failure resulting from misuse, abuse, mismanagement, negligence, alteration, accident, or lack of proper maintenance, or from lightning strikes, electrical power surges or interruption of electricity.
- Product experienced corrosion, material deterioration and/or equipment malfunction caused by or consistent with the application of chemicals, minerals, sediments or other foreign elements.
- Product was used for any purpose other than for the care of poultry and livestock.
-

The Warranty and Extended Warranty may only be modified in writing by an officer of CHORE-TIME. CHORE-TIME shall have no obligation or responsibility for any representations or warranties made by or on behalf of any distributor, dealer, agent or certified representative.

Effective: April 2014

Contents

Topic	Page
Limited Warranty	2
Support Information	4
Safety and General Information	5
Follow Safety Instructions	5
Decal Descriptions	5
DANGER: Moving Parts	5
DANGER: Electrical Hazard	5
General and Planning Information	6
Installation	7
Dead End Fill System Installation	7
Feed Manifold Installation	7
Fill System Installation	7
Drop Tube Installation for Single Fill Systems	8
Switch Installation	8
Drop Installation for Twin Systems (Model 90 & 108)	9
Fill System Installation (Outside the Building)	10
Wiring	11
Single Phase Wiring for all systems except Model 108 Two Motor Tandem (w/o Starters)	11
Single Phase Wiring for Model 108 Two Motor Tandem (w/o Starters)	12
Single Phase Wiring for all Systems Except Model 108 (With Starters)	13
3 Phase Wiring for all Systems (With Starters)	14
Parts Listing	15
Feed Manifold Part Numbers	15
MMB, MMBBG, Versa, Versa II, Versa Plus Cages	15
DURA, DURAKO, DURA-STEP, DURA II, BG Curtain Back, BG Stacked, BG 2+2, BG DBS, and BG ST Cages	16

Support Information

The ULTRAFLO Dead End Fill System is designed to convey poultry feed types. Using this equipment for any other purpose or in a way not within the operating recommendations specified in this manual will void the warranty and may cause personal injury and/or death.

This manual is designed to provide comprehensive planning, installation, wiring, operation, and parts listing information. The Table of Contents provides a convenient overview of the information in this manual. The Table of Contents also specifies which pages contain information for the sales personal, installer, and consumer (end user).

IMPORTANT: CE stands for certified Europe. It is a standard which equipment must meet or exceed in order to be sold in Europe. CE provides a benchmark for safety and manufacturing issues. CE is required only on equipment sold in Europe.

Chore-Time Equipment recognizes CE Mark and pursues compliance in all applicable products. Please fill in the CE-Mark serial number in the blank space provided for future reference.

Please include the name and address of your Chore-Time Distributor and installer.



(CE-mark serial number)

Please fill in the following information about your ULTRAFLO Dead End Fill System. Keep this manual in a clean, dry place for future reference.

Distributor's Name _____

Distributor's Address _____

Distributor's Phone _____

Date of Purchase _____

Installer's Name _____

Installer's Address _____

Installer's Phone _____

Date of Installation _____

System Specifications _____

Feed Delivery System Supplying _____

Safety and General Information

Caution, Warning and Danger Decals have been placed on the equipment to warn of potentially dangerous situations. Care should be taken to keep this information intact and easy to read at all times. Replace missing or damaged safety decals immediately.

Safety–Alert Symbol



This is a safety–alert symbol. When you see this symbol on your equipment, be alert to the potential for personal injury. This equipment is designed to be installed and operated as safely as possible...however, hazards do exist.

Understanding Signal Words

Signal words are used in conjunction with the safety–alert symbol to identify the severity of the warning.



DANGER indicates an imminently hazardous situation which, if not avoided, **WILL** result in death or serious injury.



WARNING indicates a potentially hazardous situation which, if not avoided, **COULD** result in death or serious injury.



CAUTION indicates a hazardous situation which, if not avoided, **MAY** result in minor or moderate injury.

Follow Safety Instructions

Carefully read all safety messages in this manual and on your equipment safety signs. Follow recommended precautions and safe operating practices.

Keep safety signs in good condition. Replace missing or damaged safety signs.

Decal Descriptions

DANGER: Moving Parts

Disconnect electrical power before working on system, equipment may start automatically. Otherwise personal injury will result.

Severe personal injury will result if the equipment is operated without covers properly installed.

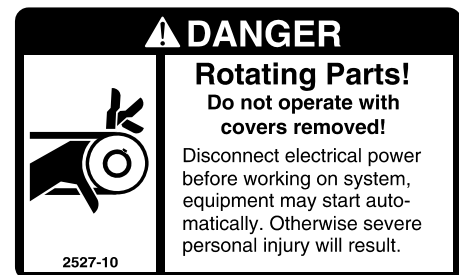

DANGER: Electrical Hazard

Disconnect electrical power before inspecting or servicing equipment unless maintenance instructions specifically state otherwise.

Ground all electrical equipment for safety.

All electrical wiring must be done by a qualified electrician in accordance with local and national electric codes.

Ground all non-current carrying metal parts to guard against electrical shock.

Electrical disconnects and over current protection are not supplied with the equipment.

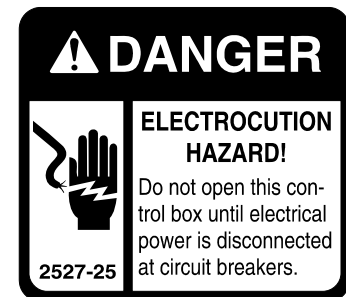

General and Planning Information

Thank you for purchasing a CHORE-TIME Dead End Fill System.

Carefully read all the instructions prior to beginning the installation.

White rust is caused by moisture trapped between galvanized parts. If moisture is present, separate parts and allow for good air circulation.

CHORE-TIME fill systems and feeding systems are designed to handle most common poultry feeds. However, we cannot guarantee satisfactory operation with all rations. We suggest you contact the CHORE-TIME Technical Service Department concerning the use of new or unusual formulations.

The Dead End Fill System is used to supply the ULTRAFLO Feeding System with feed. The ULTRAFLO Feeding System Installation Manual (MC656) is included with the Intake Cups and covers the feeding system installation process.

The Dead End Fill System is used to deliver feed from the feed bins to the ULTRAFLO Cage Feeder as required. The Dead End Fill System is designed for tier feeding applications only. Row feeding applications require use of the ULTRAFLO Loop Fill System. See the ULTRAFLO Loop Fill System Installation Manual (MC1191).

The Dead End Fill System may be a Model 90, Twin Model 90, Model 108, or Hi-Speed Model 108, depending on the capacity required (number of ULTRAFLO Feeder Lines to be supplied). Twin Model 108 Dead End Fill Systems are also available for split-ration applications only.

The chart below shows the delivery capacities of the various Dead End Fill Systems available.

Systems	Pounds/ Minute	Pounds/ Hour	Kg./ Minute	Kg./ Hour	# of Lines Supplied
Model 90	100	6,000	45	2,700	4
Twin Model 90	200	12,000	90	5,400	8
Model 108	220	13,200	98	5,800	8
Hi-Speed Model 108	250	15,000	113	6804	8

Related Instruction Manuals

Related Instruction Manuals

Inst. No.

Two Motor Tandem System Manual (Model 90)	MA524
Two Motor Tandem System Manual (Model 108)	MA1101
Model 55, 75, 90, & HMC FLEX-AUGER Fill System Manual	MA1000
Model 108 FLEX-AUGER Fill System Manual	MA1032
Dual Model 90 Control Unit	MA1277
Dual Model 108 Control Unit	MA1064
Model 90, 108, & Dual 90 Feed Screener Manual	MC1033
ULTRAFLO Feeding System Manual	MC656

Note: Some of the instructions listed above are available in various languages. Contact your CHORE-TIME Distributor for additional manuals.

Installation

Dead End Fill System Installation

Feed Manifold Installation

1. The Intake Cups should be installed according to the ULTRAFLO Feeding System Installation Instructions (MC656).
2. Install the Feed Manifolds with the drop-outs in the Intake Cups, as shown in Figure 1.
3. Slide the Feed Manifolds down into the Intake Cups 3/4" (19 mm) to 1" (25 mm).

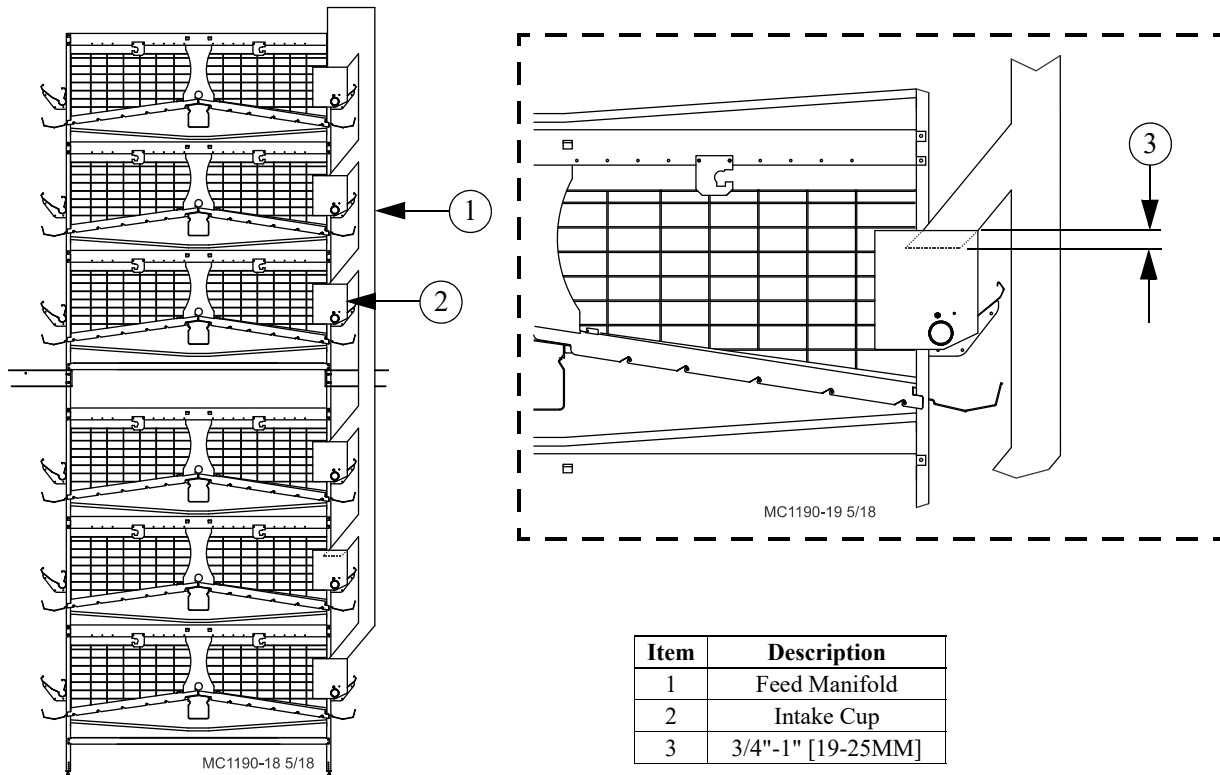

Figure 1. Feed Manifold Installation

Fill System Installation

Install the inside portion of the Fill System according to the appropriate Fill System Installation Manual (MA1702 for Model 90 Fill Systems, MA1714 for Model 108 Fill Systems, MA1712 for Model 90 & Model 108 Screeners).

NOTE: CAREFUL PLANNING IS REQUIRED. Make sure that the inside and outside portions of the Fill System are going to match up prior to beginning to install the equipment.

The Control Unit must be located directly over the Feed Manifold farthest from the Feed Bin.

An Outlet Drop must be located directly above each Feed Manifold. If possible do not install an Outlet Drop on or just before an elbow. If the Outlet Drop **MUST** be installed on or just before an elbow, reduce the size of the outlet hole to provide some feed bypass to cushion the auger.

The Fill System should be suspended approximately 12" (31 cm) above the Feed Manifolds.

Drop Tube Installation for Single Fill Systems

Cut the Drop Tubes to length and assemble on to the bottom of the Outlet Drop. (See Figure 2.)

The Drop Tubes should extend down into the top of the Feed Manifolds approximately 2” (50 mm) as shown.

Model 90 and Twin 90: Secure the Drop Tube onto the Outlet Drop using the Hose Clamp supplied.

Model 108: Secure the Drop Tube onto the Outlet Drop using the self-tapping screws supplied.

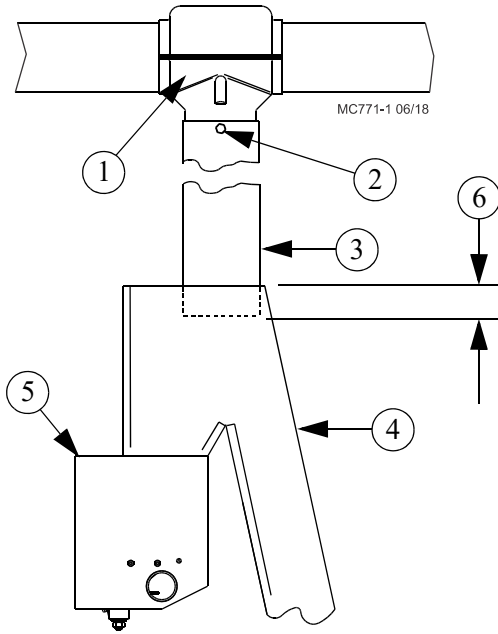

Item	Description
1	Outlet Tube (Model 108 shown)
2	Self-Tapping Screw (Note: Model 90 uses a Hose Clamp in place of Self Tapping Screw.
3	Drop Tube
4	Feed Manifold
5	Intake Cup
6	2" [50mm]

Figure 2.Drop Tube Installation (Single Fill Systems)

Switch Installation

The Proximity Level Switch Assembly is designed to provide reliable feed sensing in confinement poultry applications.

The ULTRAFLO version of the Proximity Level Switch does not include any switching relays or contactors and is intended to switch only control circuitry (not motor current).

The Switch is used to start and stop the Fill System during a feeding cycle.

Figure 3 shows a Proximity Level Switch installed. Refer to the Installation Instructions (MA1713) shipped with the Proximity Level Switch for detailed installation and wiring information.

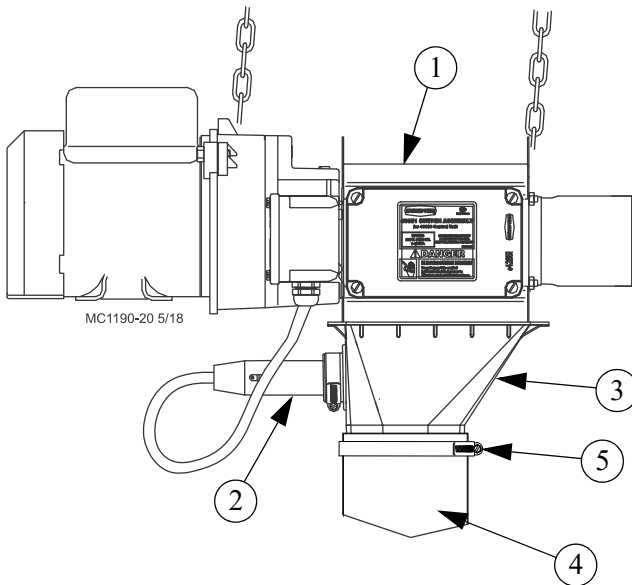

Item	Description
1	Dead End Fill System Control Unit
2	Proximity Switch
3	Control Unit Drop Assembly
4	Drop Tube
5	Hose Clamp

Figure 3.Switch Installation

Drop Installation for Twin Systems (Model 90 & 108)

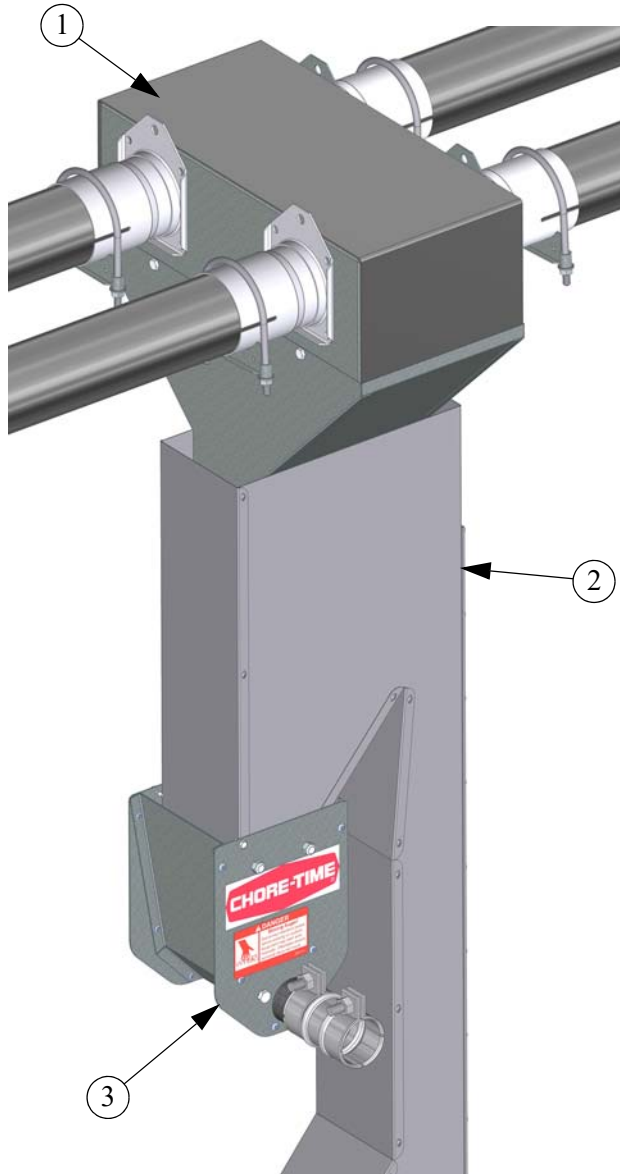

Model 90 (41943) Model 108 (41961-1,2)	
Item	Description
1	Twin All Out Drop Assembly
2	Feed Manifold
3	Intake Cup

Figure 4. Drop Installation for Twin Systems

Fill System Installation (Outside the Building)

Install the outside portion of the Fill System according to the appropriate Fill System Installation Manual (MA1702 for Model 90, MA1714 for Model 108) (See Figure 5.)

If a Feed Screener is to be used, refer to the Feed Screener Installation Manual (MC1033) for planning and installation information.

NOTE: CAREFUL PLANNING IS REQUIRED. Make sure that the inside and outside portions of the Fill System are going to match up prior to beginning to install the equipment.

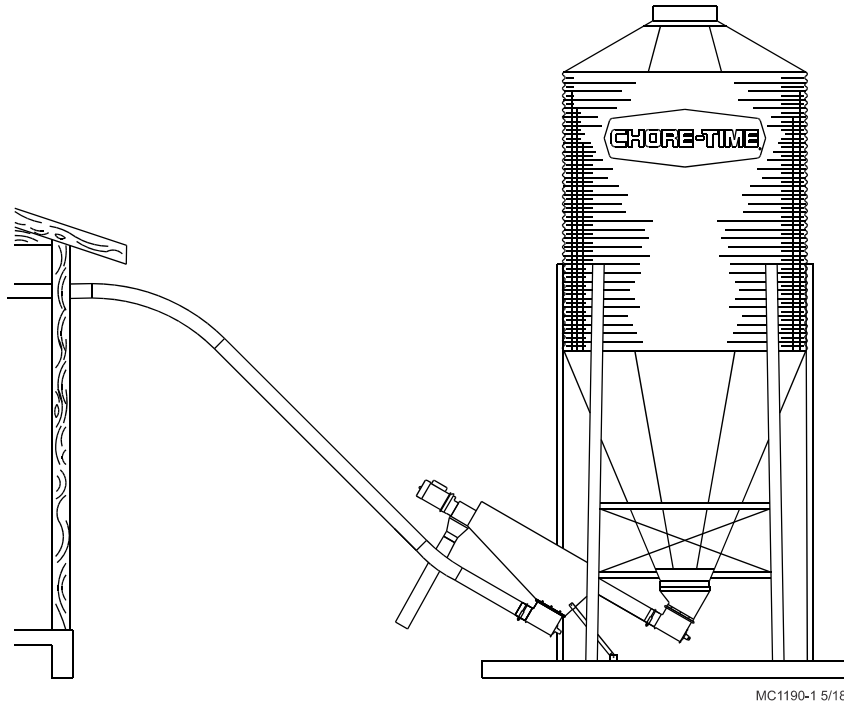

Figure 5. Fill System Installation

If it is necessary to cut an elbow, refer to Figure 6. Always measure along the outside radius of the elbow when determining cut location. Use an abrasive cut-off saw to cut the hardened steel elbows.

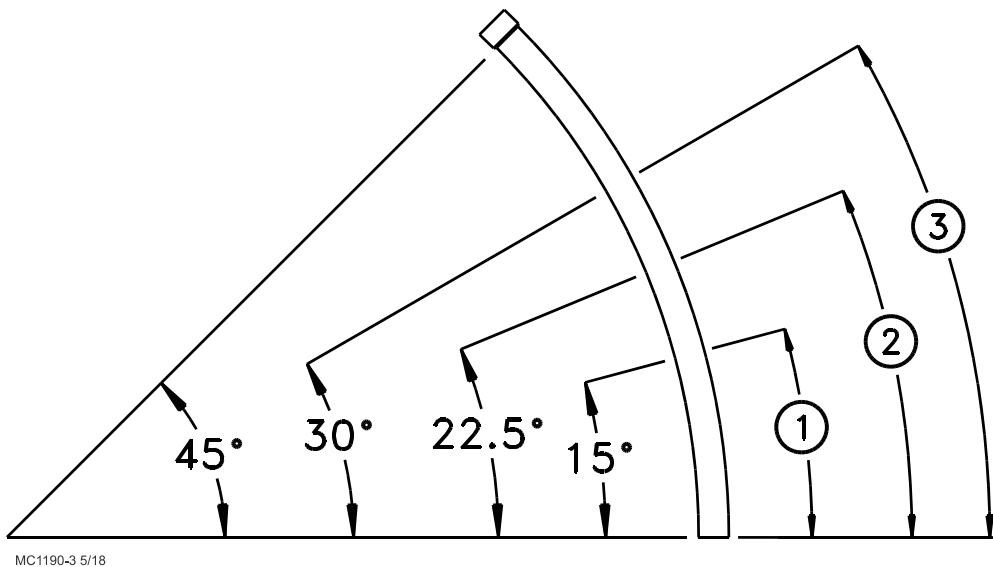

Figure 6. Cutting the Elbow

Wiring

Single Phase Wiring for all systems except Model 108 Two Motor Tandem (w/o Starters)

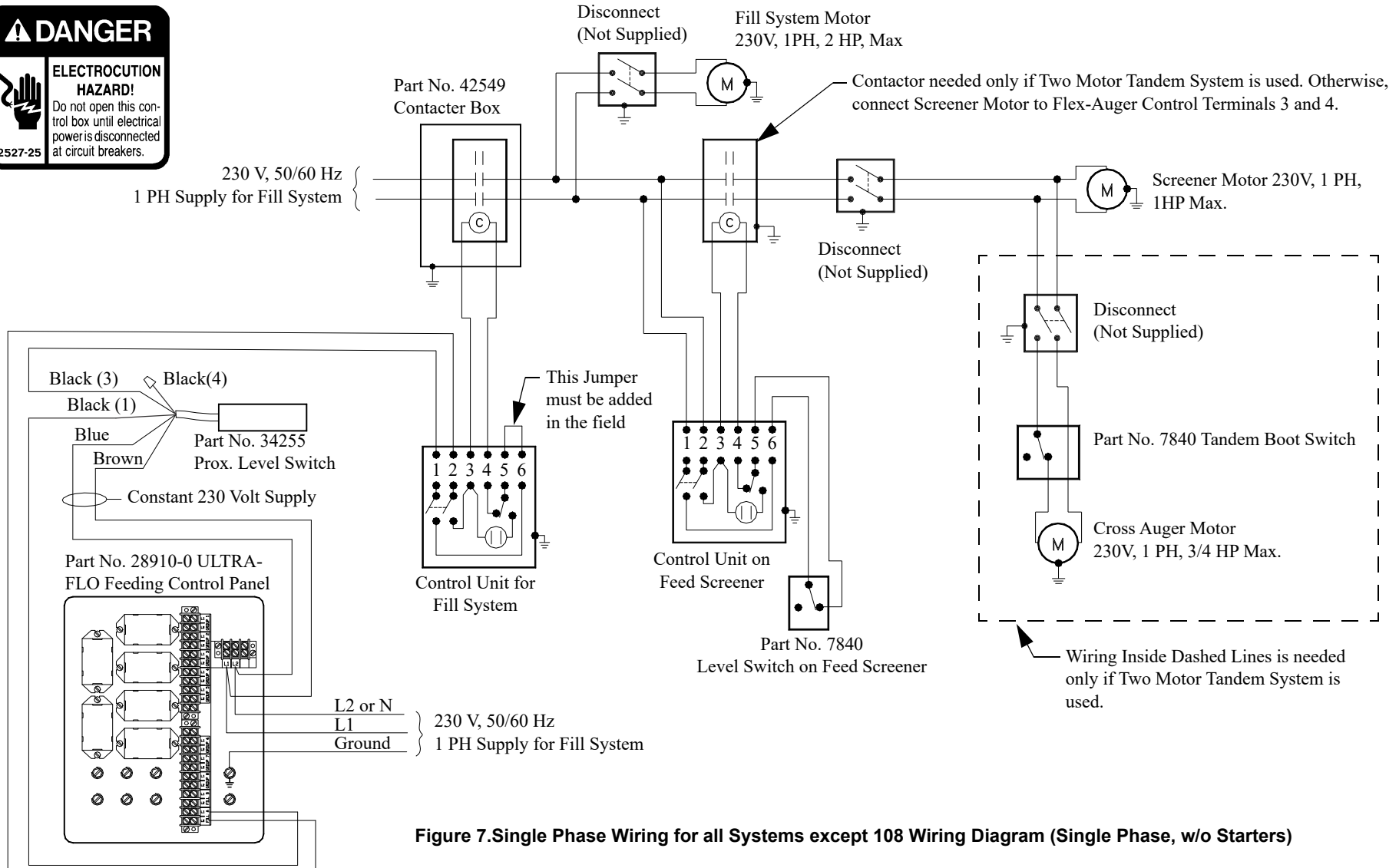
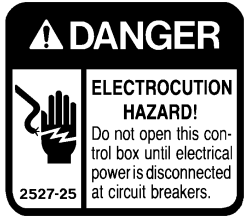

Figure 7. Single Phase Wiring for all Systems except 108 Wiring Diagram (Single Phase, w/o Starters)

Single Phase Wiring for Model 108 Two Motor Tandem (w/o Starters)

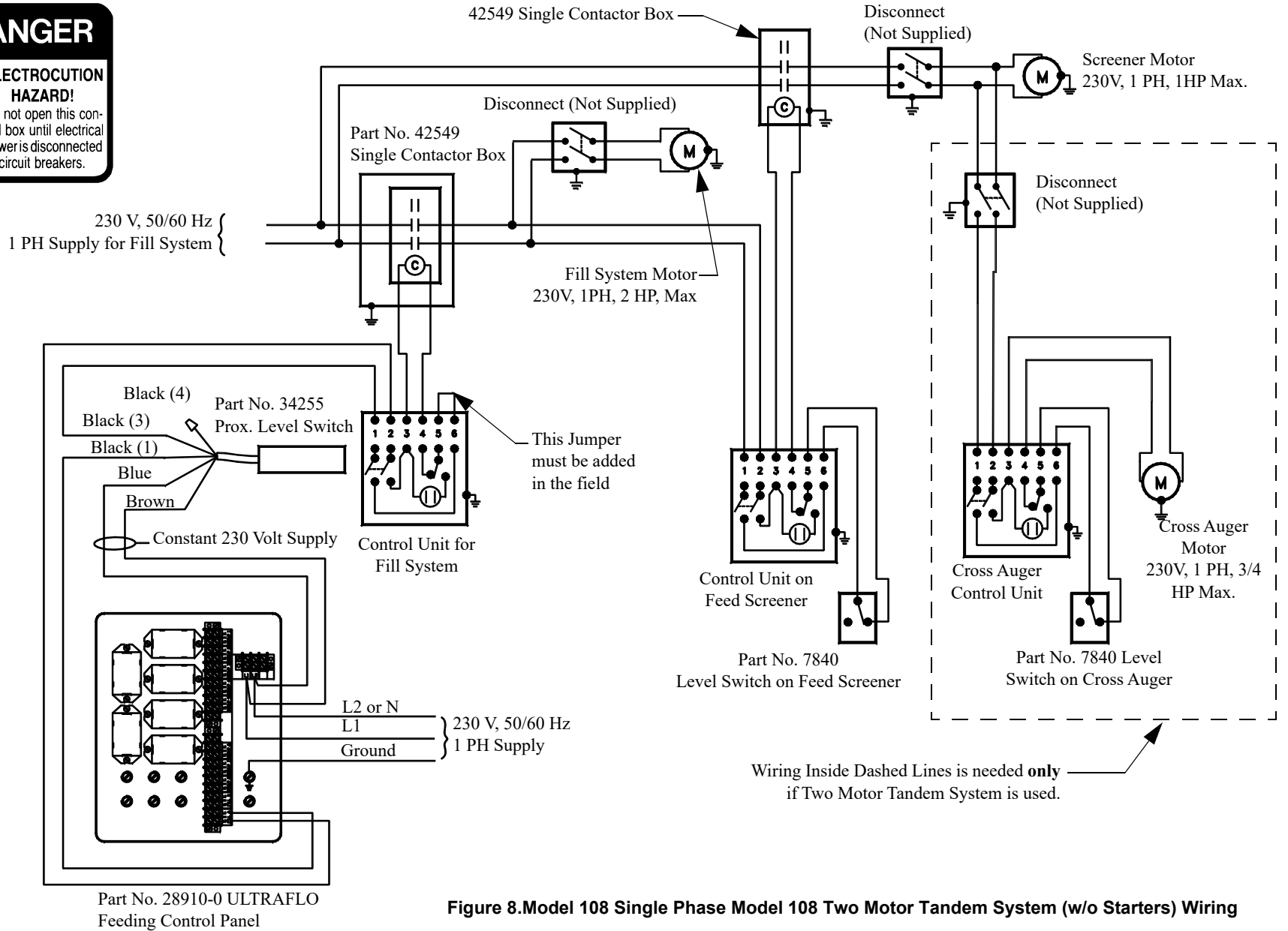
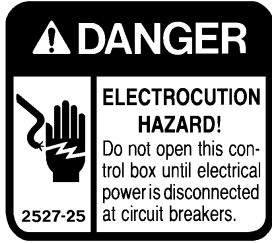

Figure 8. Model 108 Single Phase Model 108 Two Motor Tandem System (w/o Starters) Wiring

Single Phase Wiring for all Systems Except Model 108 (With Starters)

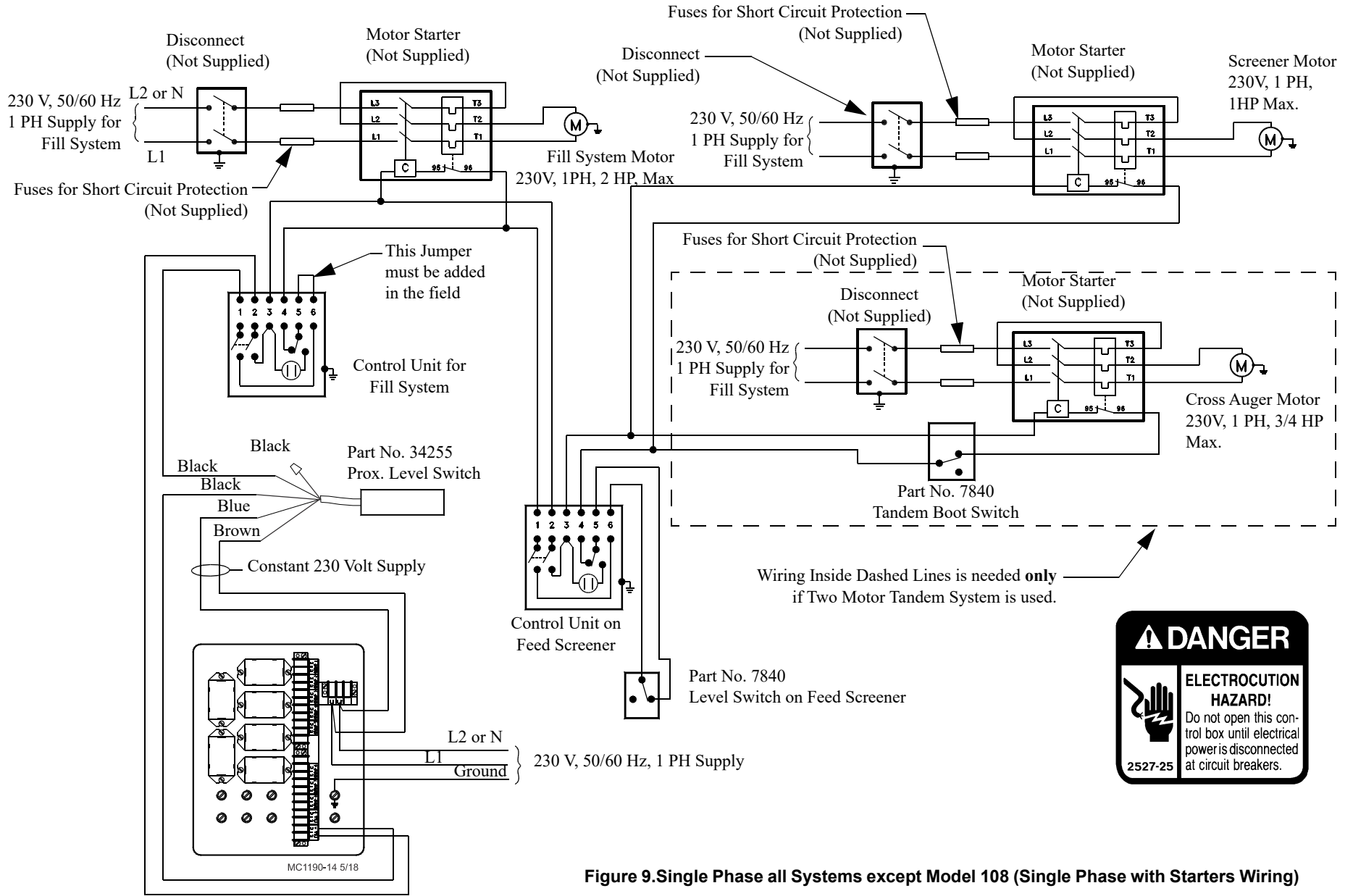
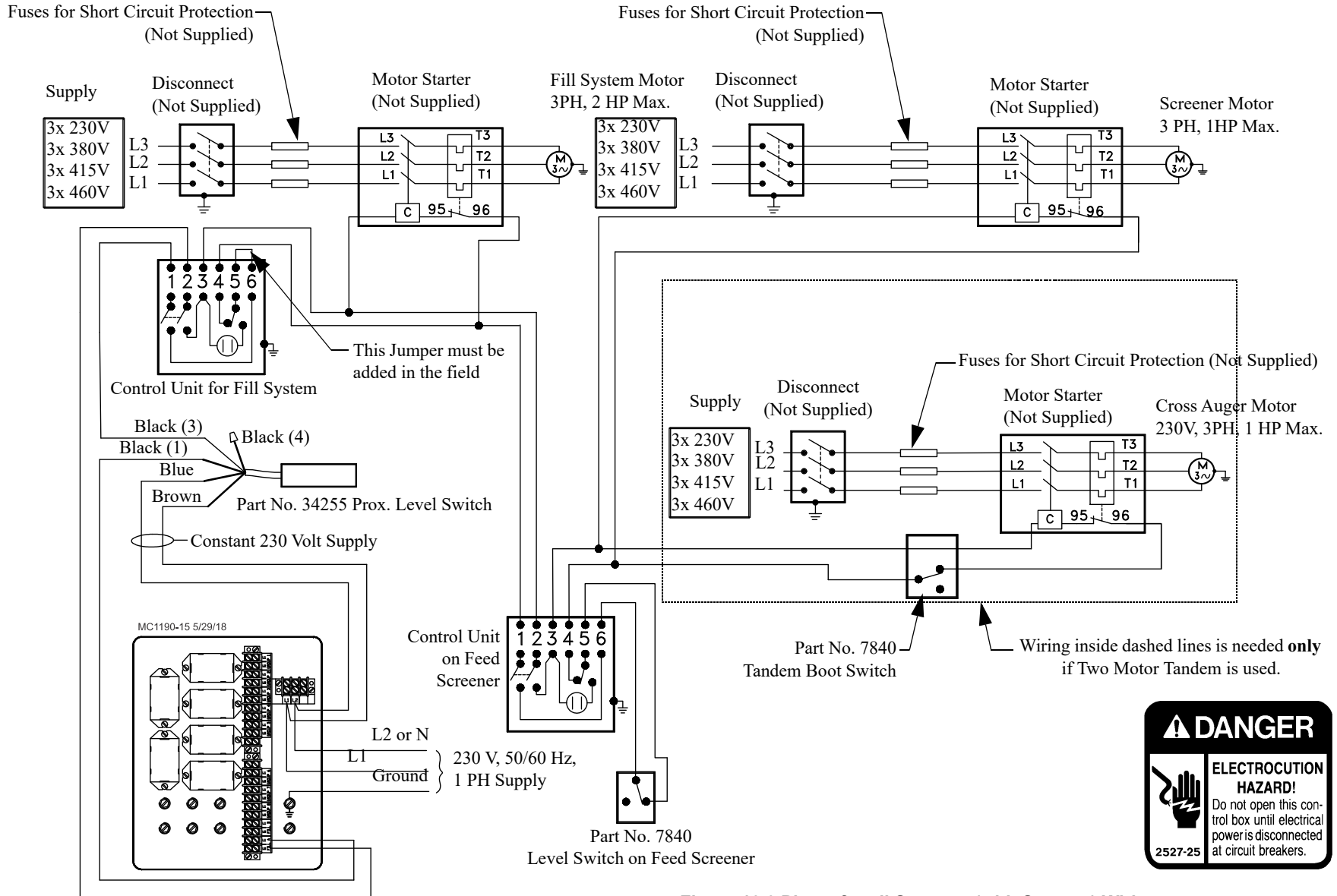

Figure 9. Single Phase all Systems except Model 108 (Single Phase with Starters Wiring)

Part No. 28910-0 ULTRAFLO Feeding Control Panel

3 Phase Wiring for all Systems (With Starters)



Part No. 28910-0 ULTRAFLO Feeding Control Panel

Figure 10.3 Phase for all Systems (with Starters) Wiring

Parts Listing

Feed Manifold Part Numbers

MMB, MMBBG, Versa, Versa II, Versa Plus Cages

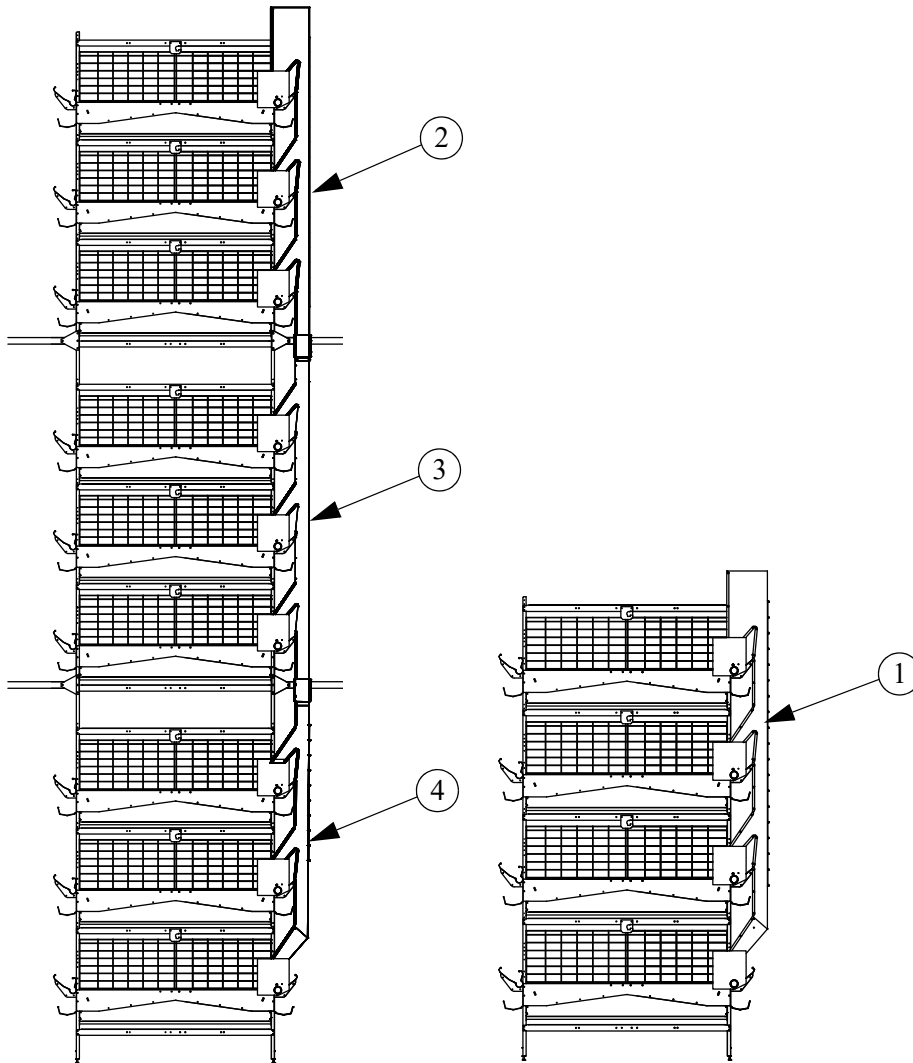

			MMB Cages	MMBBG Cages	Versa, Versa II, & Versa Plus
Item	Manifold Type	Number of Tiers	Manifold Part Numbers		
1	Combined	3	55557-3	55047	55318
		4	55557-4	55048	55319
		5	55557-5	55050	--
2	Top	2	55559-2	--	55315
		3	55559-3	54652	55316
		4	55559-4	55019	55274
		5	55559-5	--	--
3	Center	3	55705-3	55052	55317
		4	55705-4	--	55273
4	Bottom	3	55558-3	54653	55272
		4	55558-4	55018	55300
		5	55558-5	54420	--

DURA, DURAKO, DURA-STEP, DURA II, BG Curtain Back, BG Stacked, BG 2+2, BG DBS, and BG ST Cages.

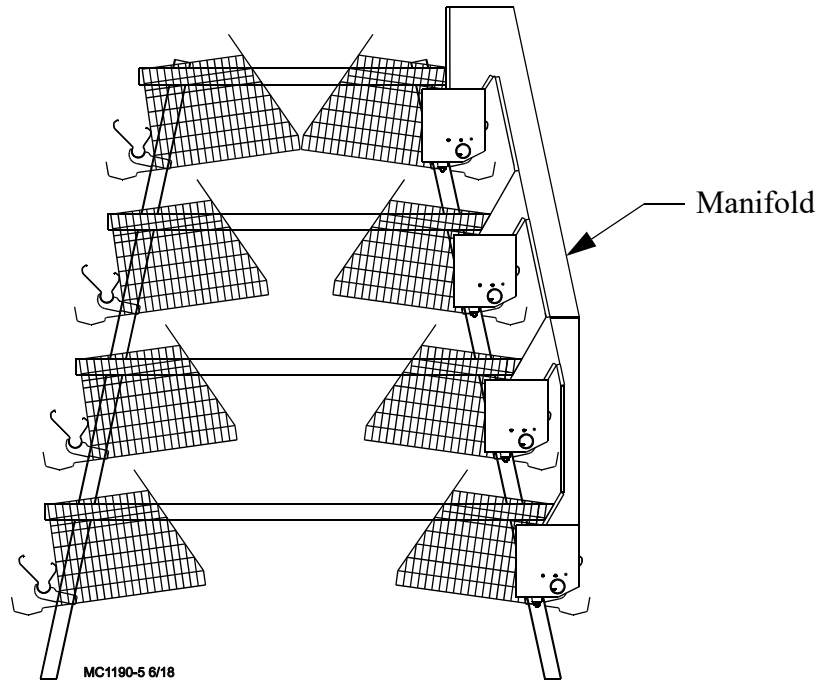

	DURA-CAGE™	DURA-TRIM™ DBS	DURAKO	DURA™ STEP	DURA™ II	Brood-Grow Curtain Back	Brood-Grow Stacked	Brood-Grow 2+2 (14")	Brood-Grow 2+2 (15")	Brood-Grow DBS	Brood-Grow ST
# of Tiers	Manifold Part Numbers										
2	--	--	--	25530	--	--	25357	--	--	--	25807
3	24850	--	--	--	27246	--	--	--	--	--	--
4	24795	35194	35194	--	--	24463	--	24509	26028	25781	--
5	28570	36777	--	--	--	--	--	--	--	--	--

This page left blank intentionally.....

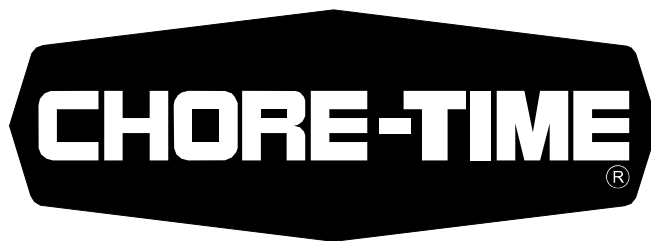

MADE TO WORK.

BUILT TO LAST.®

Revisions to this Manual

Page No.	Description of Change
Various	Updated Manual with new Cage Styles

Contact your nearby Chore-Time distributor or representative for additional parts and information.

Chore-Time Group
A division of CTB, Inc.
PO Box 2000
Milford, Indiana 46542-2000 USA
Phone (574) 658-4101 Fax (877) 730-8825
E-mail: www.choretimepoultry.com
Internet: poultry@choretime.com