

# CHORE-TIME<sup>®</sup>

## FLEX-AUGER<sup>®</sup> Feed Delivery System Installation Instruction

for

Model 108 FLEX-AUGER<sup>®</sup> Feed Delivery Systems

Installation and Operators Manual

Installation and Operators Manual

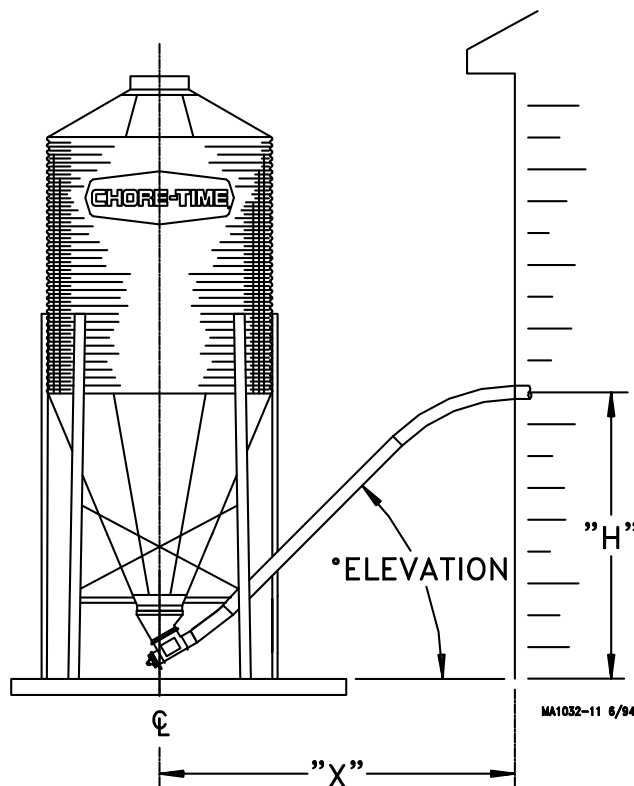

For additional parts and information, contact your nearest Chore-Time distributor or representative.  
Find your nearest distributor at: [www.choretime.com/contacts](http://www.choretime.com/contacts)

CTB, Inc.  
PO Box 2000  
Milford, Indiana 46542-2000 USA  
Phone (574) 658-4101 Fax (877) 730-8825  
Email: [choretime@choretime.com](mailto:choretime@choretime.com)  
Internet: [www.choretime.com](http://www.choretime.com)

# Contents

Topic	Page
<b>Limited Warranty</b> .....	<b>4</b>
<b>Safety and General Information</b> .....	<b>5</b>
Follow Safety Instructions .....	5
Decal Descriptions .....	5
DANGER: Moving Auger .....	5
DANGER: Electrical Hazard .....	5
DANGER: Springing Auger .....	5
<b>General Information</b> .....	<b>6</b>
Tools Needed to install your model 108 System include: .....	6
Capacities and Specifications of the Model 108 Feed Delivery System .....	7
Glossary of Terms .....	8
Planning the Model 108 Feed Delivery System .....	9
<b>Planning</b> .....	<b>11</b>
Systems Not Allowed .....	13
Model 108 Bin Placement Chart .....	14
Model 108 Bin Placement Chart (with In-Line or Rotated Screeners) .....	15
30° or Straight-Out Bin Boot with Feed Screener Boot Rotated 90° .....	16
30° Bin Boot with Feed Screener .....	16
Straight-Out Bin Boot with Feed Screener .....	17
<b>Installation</b> .....	<b>18</b>
Bin Location .....	18
Boot Installation .....	18
Auger Tube Installation .....	19
Outlet Drop Installation .....	20
Supporting the System Inside the Building .....	22
Supporting the System Outside the Building .....	23
Screeners .....	23
High Rise Auger Tube Support .....	23
Long Elevated Systems .....	24
Bin to Bin Support Systems .....	24
Straight-Through Tandem Systems .....	24
Control Unit & Power Unit Installation .....	25
Belt Drive Control Unit Installation .....	26
Auger Installation .....	26
Cover Plate Installation .....	28
Auger Brazing .....	28
Restrictor Adjustment .....	29
Feed Level Control Installation .....	30
Types of Boot Installations .....	30
Straight-Through Tandem Boot Installation .....	30
PVC Straight-Through Tandem .....	30
Steel Straight-Through Tandem .....	31
<b>Wiring</b> .....	<b>32</b>
Electrical Component Location Diagrams .....	32
Single Boot Systems using a Hopper Level Control .....	32
Model 108 Systems using a Hopper Level Control Switch .....	32
Model 108 Systems using a Hopper Level Control .....	33
Model 108 Systems using a Hopper Level Control (Three Phase) .....	33
<b>Operating Recommendations</b> .....	<b>34</b>

**Start-Up Procedure for New Systems . . . . .35**

**Parts Listing . . . . .36**

    Miscellaneous Line Components . . . . .36

    Model 108 Drop Kit (Part No. 34358) . . . . .36

    Power Units . . . . .37

    Single Phase Direct Drive Control Unit (Part No. 6500-22) . . . . .38

    Single Phase Belt Drive Control Unit (Part No. 6500-21) . . . . .39

    Three Phase Direct Drive Control Unit (Part No. 25770-6) . . . . .41

    Model 108 Boot Components . . . . .42

    Model 108 Boot Components . . . . .43

    Model 108 Boot Components (continued) . . . . .44

**Troubleshooting . . . . .45**

**Maintenance . . . . .47**

    Proximity Switch Adjustment Procedures: . . . . .48

    Cementing the PVC Auger Tube . . . . .49

**Livestock and Poultry Feed Consumption . . . . .49**

    Poultry . . . . .49

    Hogs . . . . .49

    Dairy . . . . .49

    Cementing the PVC Auger Tube . . . . .50

**Livestock and Poultry Feed Consumption . . . . .50**

    Poultry . . . . .50

    Hogs . . . . .50

    Dairy . . . . .50

## Limited Warranty

### LIMITED WARRANTY

Chore-Time Group, a division of CTB, Inc. (“Chore-Time”) warrants new CHORE-TIME CHORE-TIME FLEX-AUGER System Parts and Components manufactured by Chore-Time to be free from defects in material or workmanship under normal usage and conditions, for One (1) year from the date of installation by the original purchaser (“Warranty”). Chore-Time provides for an extension of the aforementioned Warranty period (“Extended Warranty Period”) with respect to certain Product parts. If such a defect is determined by Chore-Time to exist within the applicable period, Chore-Time will, at its option, (a) repair the Product or Component Part free of charge, F.O.B. the factory of manufacture or (b) replace the Product or Component Part free of charge, F.O.B. the factory of manufacture. This Warranty is not transferable, and applies only to the original purchaser of the Product.

### CONDITIONS AND LIMITATIONS

THIS WARRANTY CONSTITUTES CHORE-TIME’S ENTIRE AND SOLE WARRANTY AND CHORE-TIME EXPRESSLY DISCLAIMS ANY AND ALL OTHER WARRANTIES, INCLUDING, BUT NOT LIMITED TO, EXPRESS AND IMPLIED WARRANTIES, INCLUDING, WITHOUT LIMITATION, WARRANTIES AS TO MERCHANTABILITY OR FITNESS FOR PARTICULAR PURPOSES. CHORE-TIME shall not be liable for any direct, indirect, incidental, consequential or special damages which any purchaser may suffer or claim to suffer as a result of any defect in the Product. Consequential or Special Damages as used herein include, but are not limited to, lost or damaged products or goods, costs of transportation, lost sales, lost orders, lost income, increased overhead, labor and incidental costs, and operational inefficiencies. *Some jurisdictions prohibit limitations on implied warranties and/or the exclusion or limitation of such damages, so these limitations and exclusions may not apply to you. This warranty gives the original purchaser specific legal rights. You may also have other rights based upon your specific jurisdiction.*

Compliance with federal, state and local rules which apply to the location, installation and use of the Product are the responsibility of the original purchaser, and CHORE-TIME shall not be liable for any damages which may result from non-compliance with such rules.

The following circumstances shall render this Warranty void:

- Modifications made to the Product not specifically delineated in the Product manual.
- Product not installed and/or operated in accordance with the instructions published by the CHORE-TIME.
- All components of the Product are not original equipment supplied by CHORE-TIME.
- Product was not purchased from and/or installed by a CHORE-TIME authorized distributor or certified representative.
- Product experienced malfunction or failure resulting from misuse, abuse, mismanagement, negligence, alteration, accident, or lack of proper maintenance, or from lightning strikes, electrical power surges or interruption of electricity.
- Product experienced corrosion, material deterioration and/or equipment malfunction caused by or consistent with the application of chemicals, minerals, sediments or other foreign elements.
- Product was used for any purpose other than for the care of poultry and livestock.
- 

The Warranty and Extended Warranty may only be modified in writing by an officer of CHORE-TIME. CHORE-TIME shall have no obligation or responsibility for any representations or warranties made by or on behalf of any distributor, dealer, agent or certified representative.

Effective: **April 2014**

# Safety and General Information

**Caution, Warning and Danger Decals** have been placed on the equipment to warn of potentially dangerous situations. Care should be taken to keep this information intact and easy to read at all times. Replace missing or damaged safety decals immediately.

## Safety–Alert Symbol



**This is a safety–alert symbol.** When you see this symbol on your equipment, be alert to the potential for personal injury. This equipment is designed to be installed and operated as safely as possible...however, hazards do exist.

## Understanding Signal Words

**Signal words** are used in conjunction with the safety–alert symbol to identify the severity of the warning.



**DANGER** indicates an imminently hazardous situation which, if not avoided, **WILL** result in death or serious injury.



**WARNING** indicates a potentially hazardous situation which, if not avoided, **COULD** result in death or serious injury.



**CAUTION** indicates a hazardous situation which, if not avoided, **MAY** result in minor or moderate injury.

## Follow Safety Instructions

Carefully read all safety messages in this manual and on your equipment safety signs. Follow recommended precautions and safe operating practices.

Keep safety signs in good condition. Replace missing or damaged safety signs.

## Decal Descriptions

### DANGER: Moving Auger

This decal is placed on the End Cap Weldment and Clean-out cover. Severe personal injury will result, if the electrical power is not disconnected, prior to servicing the equipment.



### DANGER: Electrical Hazard

Disconnect electrical power before inspecting or servicing equipment unless maintenance instructions specifically state otherwise.

Ground all electrical equipment for safety.

All electrical wiring must be done by a qualified electrician in accordance with local and national electric codes.

Ground all non-current carrying metal parts to guard against electrical shock.

Electrical disconnects and over current protection are not supplied with the equipment.

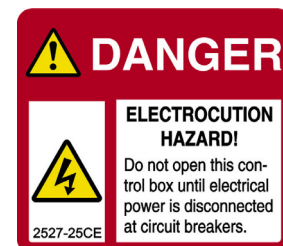

### DANGER: Springing Auger

Use caution when working with Auger. Springing Auger may cause personal injury.

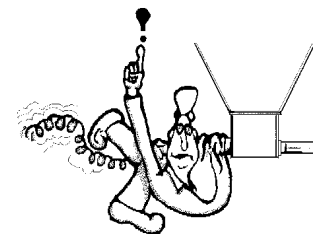

### Attention: Read the Manual

See the manual for detailed installation instructions.



# General Information

The CHORE-TIME FLEX-AUGER® Feeding System is designed to convey livestock feed types. Using this equipment for any other purpose or in a way not within the operating recommendations specified in this manual will void the warranty and may cause personal injury and/or death.

This manual is designed to provide comprehensive planning, installation, wiring, and parts listing information. The Table of Contents provides a convenient overview of the information in this manual. The Table of Contents also specifies which pages contain information for the sales personal, installer, and consumer (end user).

**IMPORTANT:** CE stands for certified Europe. It is a standard which equipment must meet or exceed in order to be sold in Europe. CE provides a benchmark for safety and manufacturing issues. CE is required only on equipment sold in Europe.



CHORE-TIME Equipment recognizes CE Mark and pursues compliance in all applicable products. Any alterations to the products will violate the CE compliance, will void the warranty, and may cause personal injury and/or death.

Please include the names and address of your CHORE-TIME Distributor.

Please fill in the following information about your Chore-Time FLEX-AUGER® Feeding System.  
Keep this manual in a clean, dry place for future reference.

**Distributor's Name** \_\_\_\_\_

**Distributor's Address** \_\_\_\_\_

**Distributor's Phone** \_\_\_\_\_ **Date of Purchase** \_\_\_\_\_

**Installer's Name** \_\_\_\_\_

**Installer's Address** \_\_\_\_\_

**Installer's Phone** \_\_\_\_\_ **Date of Installation** \_\_\_\_\_

**System Specifications** \_\_\_\_\_

**Feed Delivery System Supplying**

## Tools Needed to install your model 108 System include:

1. Regular Screwdriver
2. Allen Wrenches
3. Box-End Wrenches
4. Drive Ratchet and Sockets
5. Locking Pliers
6. File
7. Saw to cut PVC Tubes
8. 3.5" Hole Saw or Sabre Saw
9. Screw-Hook Driver
10. Bolt Cutters or Hack Saw
11. PVC Cleaning Solvent
12. Wire Cutters
13. Wire Strippers
14. Adequate Size and Quantity of Electrical Wire
15. Electrical Drill and Drill Bits
16. Abrasive Cut-off Saw (for steel systems only)
17. Oxy-Acetylene Torch and Brazing Rod
18. Another person to help!!

## Capacities and Specifications of the Model 108 Feed Delivery System

The Model 108 FLEX-AUGER Feed Delivery System is available with either PVC or steel auger tubes. PVC and steel tubes should not be mixed in a system.

**DO NOT USE PVC AUGER TUBING WITH FEEDS CONTAINING CALCIUM.** The steel auger tubes should be used for feeds with calcium.

The Model 108 FLEX-AUGER Feed Delivery System has an approximate conveying capacity\* of 220 pounds per minute (100 kg per minute), or 13,200 pounds per hour (6,000 kg per hour). A high capacity Model 108 system may be ordered for applications requiring up to 250 pounds per minute (113 kg per minute). The maximum recommended running time per day is 4 hours.

\*Carrying capacities are based on feed density of 40 pounds per cubic foot or 640 kg per cubic meter.

The Model 108 is designed to carry feeds such as mash, crumbles, shelled corn, high moisture corn, or pellets up to approximately 3/16" x 1/2" (4.7 x 12.7 mm) in size. **Applications other than conveying poultry and livestock rations will void the warranty.**

Adequate support must be provided to prevent the tubes from sagging and support the weight of the Control Unit. The auger, tubes, and feed weigh approximately 8 lbs/ft. (12 kg/m). The Control Unit weighs approximately 100 lbs. (45 kg).

**MAXIMUM MOISTURE CONTENT OF CORN FOR THE MODEL 108 FLEX-AUGER IS 27%.**

**MAXIMUM MOLASSES CONTENT IS 2%.**

## Glossary of Terms

The **30 Degree Boot** (left) is the standard boot used in single bin applications.

The **Straight-Out Boot** (right) may be used in multiple bin applications, elevated bins, and systems with less free flowing feed stuffs.

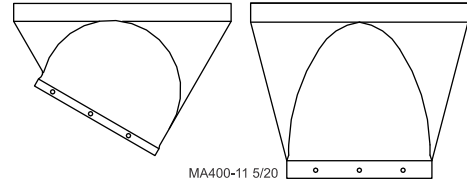

MA400-11 5/20

The **Control Unit** (right) is located at the end of the fill system. A Power Unit (left) is secured to the Control Unit to turn the auger.

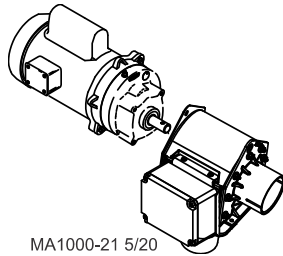

MA1000-21 5/20

The **Lower Boot Components**, located under the feed bin, include a bearing and feed restrictor.

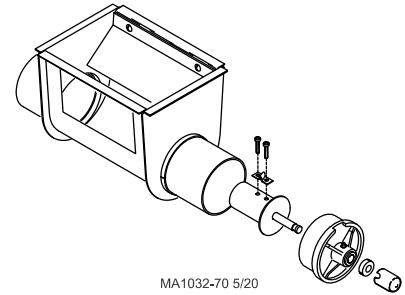

MA1032-70 5/20

An **Extension Boot** (optional) may be used to provide additional length to a system. Multiple Extension Boots may be used on very long systems.

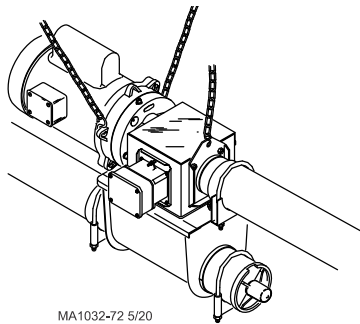

MA1032-72 5/20

An **Outlet Drop** is located at each outlet opening along the FLEX-AUGER auger line. very long systems.

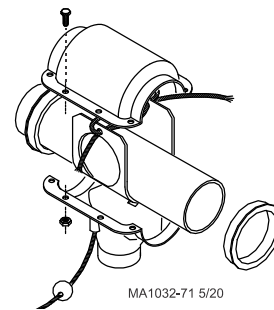

MA1032-71 5/20

The fill system may be controlled by the Drop Tube Switch (left) or the Proximity Level Switch (right). Both switches are optional and must be ordered separately.

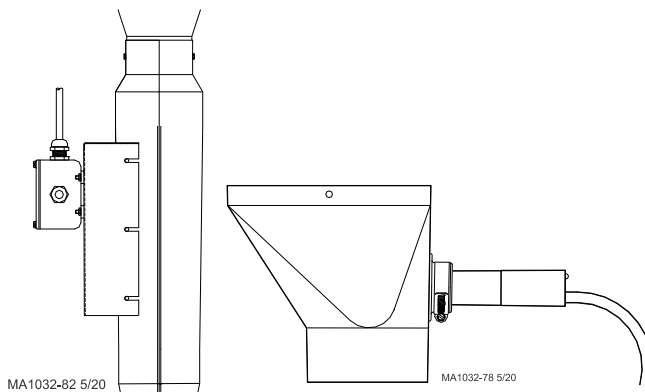

MA1032-82 5/20

MA1032-78 5/20

The **Auger Timer** (optional) is used to control the length of auger run-time. It may be used as a safety backup to prevent excessive run time.

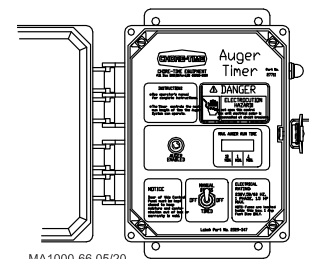

MA1000-66 05/20

The **30 Degree Two Motor Tandem Boot** (optional) is used when a cross auger is required under two feed bins. This allows the feed bins to be set at a 90 degree angle to the FLEX-AUGER feeder line.

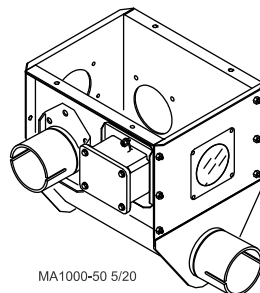

MA1000-50 5/20

The **Hopper Level Control** is used to control the feed level in the hoppers.

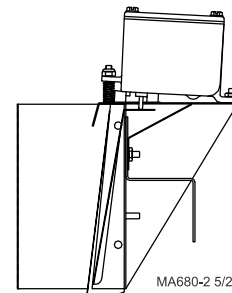

MA680-2 5/20



## Planning the Model 108 Feed Delivery System

Carefully plan the Model 108 Fill System installation. Make sure the system will not interfere with other equipment, doors, windows, etc.

The charts below provide power unit recommendations and maximum system line lengths. The top chart applies to standard 348 RPM systems. The lower chart applies to (optional) High Capacity 425 RPM systems.

<b>Maximum Line Lengths* for standard 348 RPM Systems</b>			
<b>Motor HP</b>	<b>Power Unit Part No.</b>	<b>Standard System</b>	<b>Extended System</b>
3/4	3259-52	50 Ft. (15.2 m)	75 Ft. (22.8 m)
1	3259-49	100 Ft. (30.5 m)	135 Ft. (41.1 m)
1-1/2	3259-66	150 Ft. (45.7 m)	185 Ft. (56.4 m)

<b>Maximum Line Lengths* for High Capacity 425 RPM Systems</b>			
<b>Motor HP</b>	<b>Power Unit Part No.</b>	<b>Standard System</b>	<b>Extended System</b>
1	3259-79	50 Ft. (15.2 m)	75 Ft. (22.8 m)
1-1/2	3259-80	100 Ft. (30.5 m)	135 Ft. (41.1 m)
2	3259-121	150 Ft. (45.7 m)	185 Ft. (56.4 m)

\*Maximum line lengths should be reduced for elevations over 8' (2.4 m) and/or inclines steeper than 45 degrees.

Maximum lengths for 108 systems include use of two PVC elbows. If additional elbows are used, decrease line length by 30 ft. (9 m) per elbow. Length of extension systems do not include elbows. Decrease maximum extension system lengths by 30 ft. (9 m) per elbow if used in the system.

Horsepower requirements are based on length of the Model 108 FLEX-AUGER system and type of system installed--i.e. number of turns.

See **“Model 108 Bin Placement Chart” on page 14 through page 18** for typical bin to building placement using various elevations, boots, and screener options.

1. For the easiest installation and most trouble-free operation, locate the feed bin in a direct line with the FLEX-AUGER Feed Delivery System. The layout charts **“Model 108 Bin Placement Chart” on page 14** and **“Model 108 Bin Placement Chart (with In-Line or Rotated Screeners)” on page 15** provide some points of reference for bin placement according to the height at which the FLEX-AUGER tube enters the building. Remember, these are only examples. The layouts can be modified by changing the elbows, the tube sections, and/or the distance from the bin to the building.  
FLEX-AUGER Feed Delivery Systems operate best at an angle of no more than 60 degrees from horizontal to the entry of the building at the desired height. Chore-Time considers a 45 degree elevation to be standard. The lower the angle, the more reliable the system.
2. Lay out the system as straight as possible. Avoid extra elbows and curves by locating the feed bin in line with the feeders. One horizontal 90 degree turn is permissible inside the building. 180 degree turns are not recommended under any conditions.  
If additional turns or elbows are required, use an Extension Boot. Remember: one 90 degree elbow requires the same power as 30' (9.1 m) of straight line.
3. Plan the system so that the auger tubes are directly over the feeders or hoppers to be filled, if possible. The drop tubes may be angled to a maximum of 45 degrees from the vertical if necessary. At angles greater than 45 degrees, bridging in the drop tubes may occur.

4. The control unit must be located over a feeder or hopper that will require as much or more feed than any of the other feeders or hoppers. If frequent filling is desired, mount the drop tube switch or hopper level switch low so that this feeder or hopper will have a low feed level. This allows the feeder to call for feed more often, the system will restart, and the other feeders will be refilled sooner.
5. Do not locate outlet drops on or just before an elbow. Install the drop after the elbow so feed will cushion the auger through the curve. If there is some reason why the outlet drop cannot be moved, it must have some "feed bypass" to cushion the auger through the elbow.
6. Avoid horizontal left-hand turns if possible. The elbow in a left-hand turn is not cushioned by the feed and will wear faster. On systems with a 90 degree horizontal left-hand turn, reduce the stretch to reduce wear.

**Note:** A rule of thumb for left-hand turns is to reduce stretch to 6" per 50' (150 mm per 15 m) of auger on initial installation. After the system has been broken in, it may be necessary to increase the auger stretch to prevent auger surging.

7. On any Extended Length System, balance the power requirements between the power unit that takes feed from the bin and the power unit on the Extended Length System.

To do this, determine the total length of the system and divide by two. Subtract 20' (6.1 m) from the standard system and add 20' (6.1 m) to the extended system.

**Example:** On a 240' (73 m) system, the center of the system would be 120' (36.5 m). Subtract 20' (6.1 m) from standard system, and add it to the extended length system. The first power unit should be located approximately 100' (30 m) down the system. Locate the second power unit approximately 140' (42.7 m) from the first power unit.

# Planning

The FLEX-AUGER Delivery Systems may be readily adapted to most feed delivery applications. The systems illustrated on the following pages show the most common types of FLEX-AUGER installations. These diagrams provide guidelines for laying out your system.

See “**Systems Not Allowed**” on page 13 to see four systems that are NOT recommended. Possible alternate systems are provided with each non-recommended system.

**System A** represents a typical straight-line system with optional tandem bin set-up. If this were a long system with many outlet drops, some feed bypass should be provided by increasing the size of the outlet holes, from small at the bin end, to the large at the control end of the line.

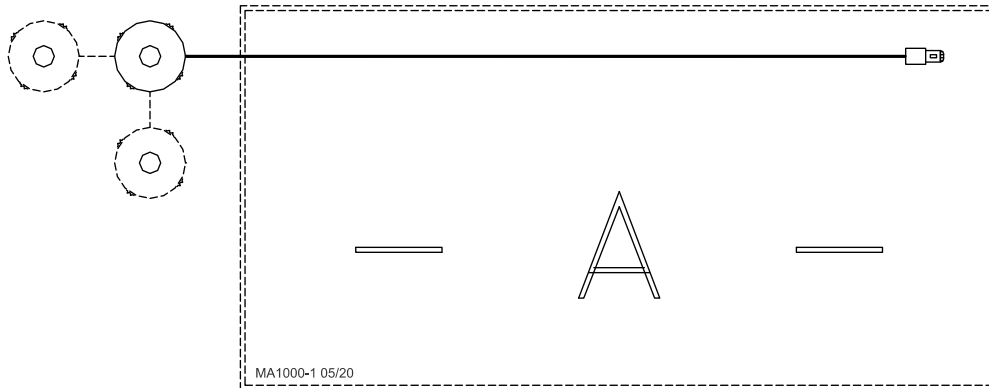

**System B** represents an extended length system. Equalize the power requirements of each part of the system. Optional equipment required.

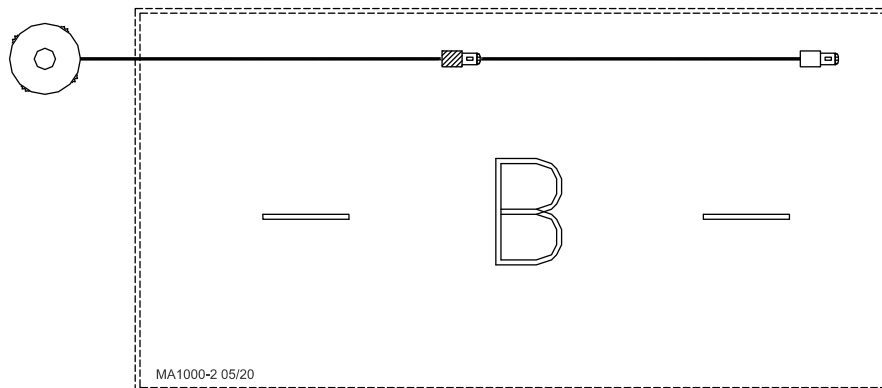

**System C** represents a twin boot system with the feed bin centered at one end of the building.

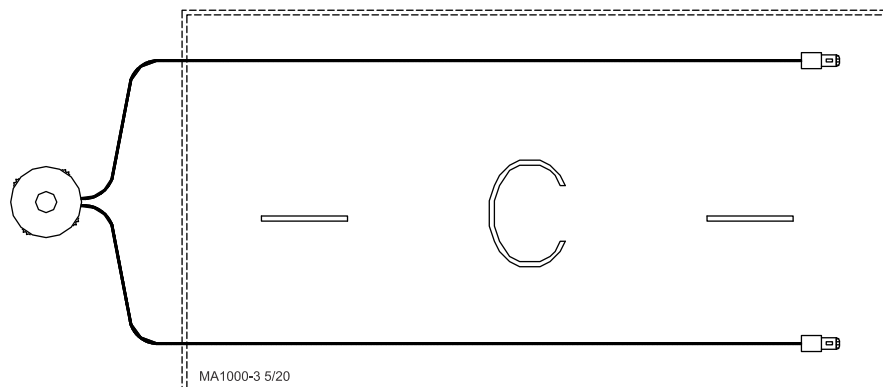

**System D** utilizes right-hand 90 degree turns. The elevations should be accomplished within the outside elbows. This system would be recommended over system E since it eliminates additional elbows and left hand turns.

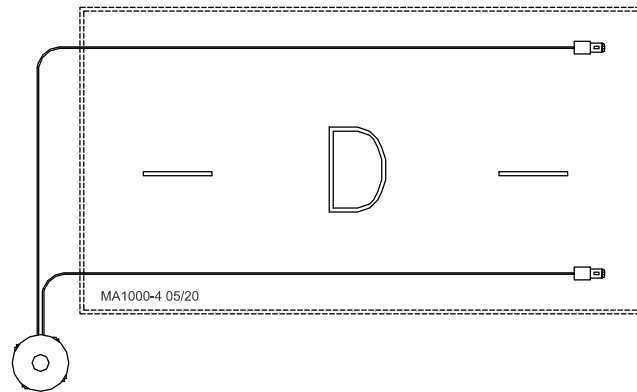

**System E** uses one additional 90 degree elbow after entering the building. Note that the elbows are left-hand turns. This system would be improved if the feed bin was moved to the opposite side of the building to provide right-hand turns instead.

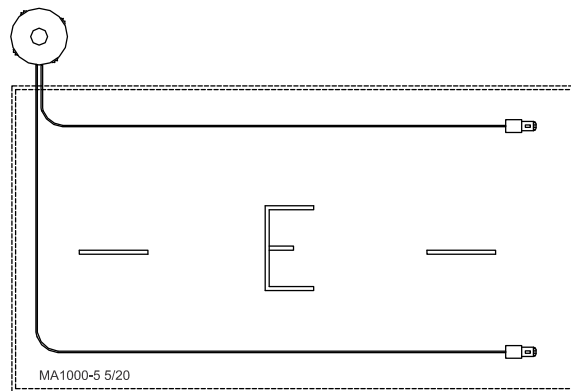

**System G** represents an extended length system with one additional 90 degree elbow. This is acceptable, but Systems C or D would be recommended (to reduce excessive run time). Optional equipment required.

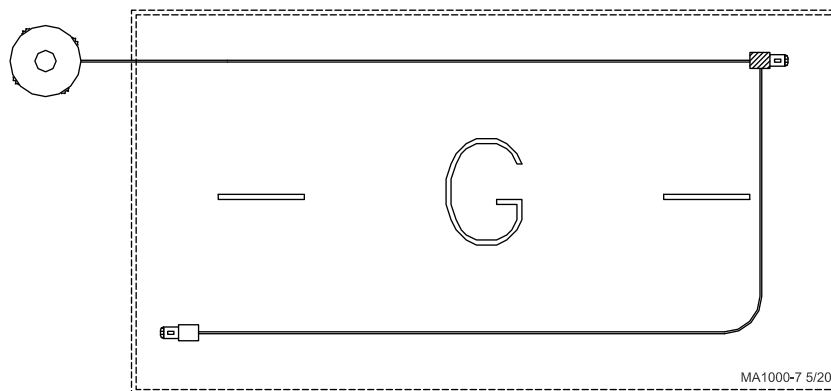

### Systems Not Allowed

**NOT ALLOWED.** System H is not recommended, due to 180 degree, left-hand turns. Erratic auger operation would be expected. The feed bin should be relocated or an Extension Hopper should be utilized as in System G.

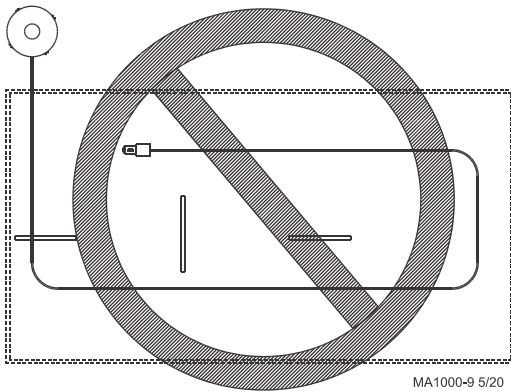
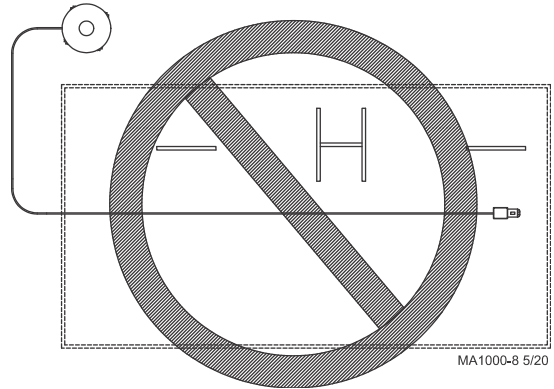

**NOT ALLOWED.** System I is not recommended, due to 180 degree, left-hand turns. Excessive elbow wear and erratic auger operation would be expected. Systems D, E, or G would be recommended.

**NOT ALLOWED.** This system uses 180 degree elbows and would be subject to premature elbow wear due to outlet drop placement before an elbow. System C would be recommended.

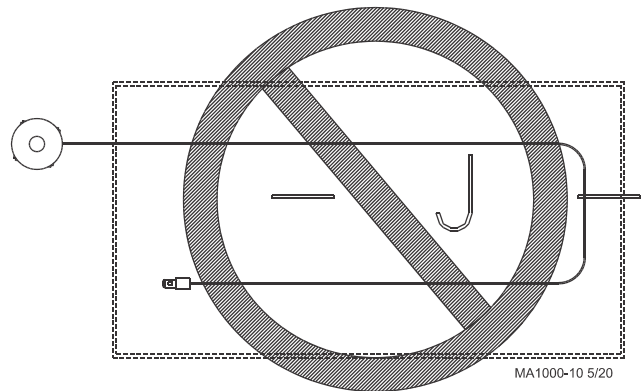

**NOT ALLOWED.** Too many elbows. The result would be auger vibration, motor stall, and excessive elbow wear. A twin system, such as C, D, or E, would be recommended; or an Extension Hopper could be utilized as in System G.

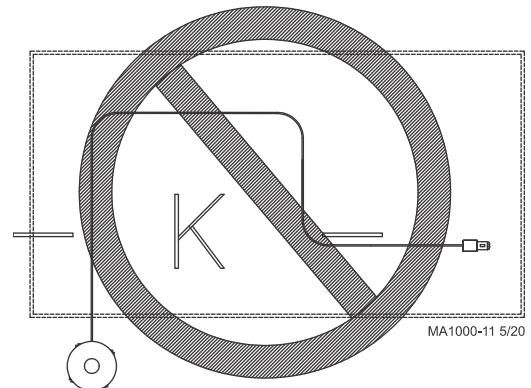

## Model 108 Bin Placement Chart

Use this chart to determine the distance from building to center of bin ("X") at the various entrance heights ("H") and degrees of elevations listed below.

Degree of elevation = Angle at which the system is installed, including the 30 degree or straight-out Upper Boot.

These layout charts are for planning and reference purposes only. A combination of elbows and straight tube may be required for your installation, depending on the distance from the bin to the building and the height at which the auger tubes are to enter the building. The elbows may be easily cut to any angle required.

**PAY PARTICULAR ATTENTION TO THE MINIMUM DISTANCE BETWEEN THE BIN AND THE BUILDING.**

Many installation and operational difficulties can be avoided if the bin is located farther from the building. If in doubt, it is **BETTER TO BE TOO FAR AWAY THAN TOO CLOSE.**

The maximum recommended angle of elevation above the horizontal is 60 degrees. The maximum elevation is 30 feet (9.1 m) . . . if the angle of elevation is no more that 45 degrees.

All systems require adequate support of the auger tubes to prevent sagging and/or excessive forces being transmitted to the bin boot.

### Distance from center of the bin to the building

System Model	Entrance Height "H"	30 Degree Upper Bin Boot (part no. 4347)			Straight-Out Upper Bin Boot (part no. 6093)		
		30 Degree	45 Degree	60 Degree	30 Degree	45 Degree	60 Degree
Model 108	5' (1.5 m)	9' (2.7 m)	-----	-----	11.5' (3.5 m)	10' (3 m)	-----
	6' (1.8 m)	11' (3.4 m)	8.5' (2.6 m)	8' (2.4 m)	13.5' (4.1 m)	11' (3.4 m)	10' (3 m)
	7' (2.1 m)	12.5' (3.8 m)	9.5' (2.9 m)	8.5' (2.6 m)	15' (4.6 m)	12' (3.7 m)	11' (3.4 m)
	8' (2.4 m)	14.5' (4.4 m)	10.5' (3.2 m)	9' (2.7 m)	17' (5.2 m)	13' (4 m)	11.5' (3.5 m)
	9' (2.7 m)	16' (4.9 m)	11.5' (3.5 m)	9.5' (2.9 m)	18.5' (5.6 m)	14' (4.3 m)	12' (3.7 m)
	10' (3 m)	17.5' (5.3 m)	12.5' (3.8 m)	10' (3 m)	20' (6.1 m)	15' (4.6 m)	12.5' (3.8 m)
	11' (3.4 m)	19.5' (5.9 m)	13.5' (4.1 m)	10.5' (3.2 m)	22' (6.7 m)	16' (4.9 m)	13' (4 m)
	12' (3.7 m)	21' (6.4 m)	14.5' (4.4 m)	11.5' (3.5 m)	23.5' (7.2 m)	17' (5.2 m)	13.5' (4.1 m)
	13' (4 m)	23' (7 m)	15.5' (4.7 m)	12' (3.7 m)	25.5' (7.8 m)	18' (5.5 m)	14' (4.3 m)
	14' (4.3 m)	24.5' (7.5 m)	16.5' (5 m)	12.5' (3.8 m)	27' (8.2 m)	19' (5.8 m)	15' (4.6 m)
	15' (4.6 m)	26.5' (8.1 m)	17.5' (5.3 m)	13' (4 m)	29' (8.8 m)	20' (6.1 m)	15.5' (4.7 m)
	16' (4.9 m)	28' (8.5 m)	18.5' (5.6 m)	13.5' (4.1 m)	30.5' (9.3 m)	21' (6.4 m)	16' (4.9 m)
	17' (5.2 m)	30' (9.1 m)	19.5' (5.9 m)	14' (4.3 m)	32.5' (9.9 m)	22' (6.7 m)	16.5' (5 m)
	18' (5.5 m)	31.5' (9.6 m)	20.5' (6.2 m)	14.5' (4.4 m)	34' (10.4 m)	23' (7 m)	17' (5.2 m)
	19' (5.8 m)	33.5' (10.2 m)	21.5' (6.5 m)	15.5' (4.7 m)	36' (11 m)	24' (7.3 m)	17.5' (5.3 m)
	20' (6.1 m)	35' (10.7 m)	22.5' (6.8 m)	16' (4.9 m)	37.5' (11.4 m)	25' (7.6 m)	18.5' (5.6 m)

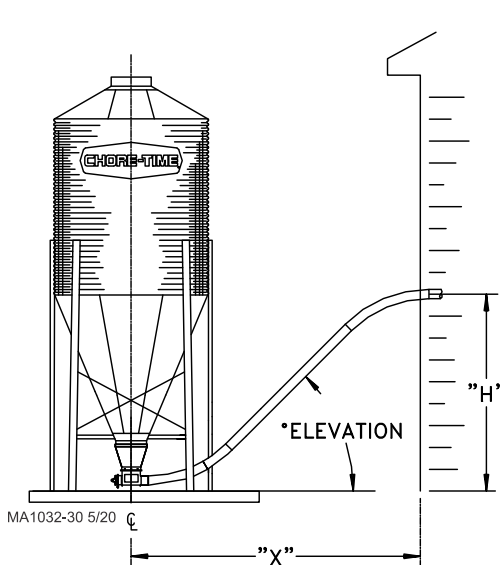

**Straight-Out Boot**

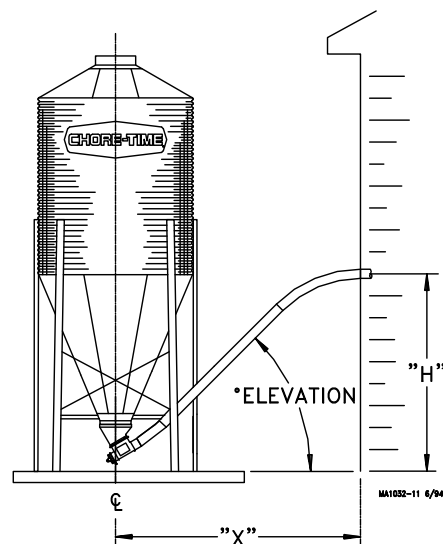

**30 Degree Boot**

### Model 108 Bin Placement Chart (with In-Line or Rotated Screeners)

Chart for minimum distances ("X") from building to center of bin using the various entrance heights ("H"), upper boots and elevations listed below.

System Model	Entrance Height "H"	30 Degree Upper Bin Boot (part no. 4347)		Straight-Out Upper Bin Boot (part no. 6093)		
		30 Degree	45 Degree	30 Degree	45 Degree	
Model 108 using screener. Screener Boot is in-line with system.	5' (1.5 m)	12.5' (3.8 m)	11.5' (3.5 m)	15' (4.6 m)	14' (4.3 m)	
	6' (1.8 m)	14' (4.3 m)	12.5' (3.8 m)	16.5' (5 m)	15' (4.6 m)	
	7' (2.1 m)	16' (4.9 m)	13.5' (4.1 m)	18.5' (5.6 m)	16' (4.9 m)	
	8' (2.4 m)	17.5' (5.3 m)	14.5' (4.4 m)	20' (6.1 m)	17' (5.2 m)	
	9' (2.7 m)	19.5' (5.9 m)	15.5' (4.7 m)	22' (6.7 m)	18' (5.5 m)	
	10' (3 m)	21' (6.4 m)	16.5' (5 m)	23.5' (7.2 m)	19' (5.8 m)	
	11' (3.4 m)	23' (7 m)	17.5' (5.3 m)	25.5' (7.8 m)	20' (6.1 m)	
	12' (3.7 m)	24.5' (7.5 m)	18.5' (5.6 m)	27' (8.2 m)	21' (6.4 m)	
	13' (4 m)	26.5' (8.1 m)	19.5' (5.9 m)	29' (8.8 m)	22' (6.7 m)	
	14' (4.3 m)	28' (8.5 m)	20.5' (6.2 m)	30.5' (9.3 m)	23' (7 m)	
	15' (4.6 m)	29.5' (9 m)	21.5' (6.5 m)	32.5' (9.9 m)	24' (7.3 m)	
	16' (4.9 m)	31.5' (9.6 m)	22.5' (6.8 m)	34' (10.4 m)	25' (7.6 m)	
	17' (5.2 m)	33' (10 m)	23.5' (7.2 m)	35.5' (10.8 m)	26' (7.9 m)	
	18' (5.5 m)	35' (10.7 m)	24.5' (7.5 m)	37.5' (11.4 m)	27' (8.2 m)	
	19' (5.8 m)	36.5' (11.1 m)	25.5' (7.8 m)	39' (11.9 m)	28' (8.5 m)	
	20' (6.1 m)	38.5' (11.7 m)	26.5' (8.1 m)	41' (12.5 m)	29' (8.8 m)	
	Model 108 using screener. Screener Boot is rotated 90 degrees to system.	5' (1.5 m)	11' (3.4 m)	9.5' (2.9 m)	11' (3.4 m)	9.5' (2.9 m)
		6' (1.8 m)	13' (4 m)	10.5' (3.2 m)	13' (4 m)	10.5' (3.2 m)
		7' (2.1 m)	14.5' (4.4 m)	11.5' (3.5 m)	14.5' (4.4 m)	11.5' (3.5 m)
		8' (2.4 m)	16' (4.9 m)	12.5' (3.8 m)	16' (4.9 m)	12.5' (3.8 m)
9' (2.7 m)		18' (5.5 m)	13.5' (4.1 m)	18' (5.5 m)	13.5' (4.1 m)	
10' (3 m)		19.5' (5.9 m)	14.5' (4.4 m)	19.5' (5.9 m)	14.5' (4.4 m)	
11' (3.4 m)		21.5' (6.5 m)	15.5' (4.7 m)	21.5' (6.5 m)	15.5' (4.7 m)	
12' (3.7 m)		23' (7 m)	16.5' (5 m)	23' (7 m)	16.5' (5 m)	
13' (4 m)		25' (7.6 m)	17.5' (5.3 m)	25' (7.6 m)	17.5' (5.3 m)	
14' (4.3 m)		26.5' (8.1 m)	18.5' (5.6 m)	26.5' (8.1 m)	18.5' (5.6 m)	
15' (4.6 m)		28.5' (8.7 m)	19.5' (5.9 m)	28.5' (8.7 m)	19.5' (5.9 m)	
16' (4.9 m)		30' (9.1 m)	20.5' (6.2 m)	30' (9.1 m)	20.5' (6.2 m)	
17' (5.2 m)		32' (9.8 m)	21.5' (6.5 m)	32' (9.8 m)	21.5' (6.5 m)	
18' (5.5 m)		33.5' (10.2 m)	22.5' (6.8 m)	33.5' (10.2 m)	22.5' (6.8 m)	
19' (5.8 m)		35.5' (10.8 m)	23.5' (7.1 m)	35.5' (10.8 m)	23.5' (7.2 m)	
20' (6.1 m)		37' (11.3 m)	24.5' (7.4 m)	37' (11.3 m)	24.5' (7.5 m)	

Use this diagram and chart to determine proper feed bin placement when using screener.

"X" = distance from center of bin to where fill system enters the building.

"H" = height from top of bin pad to where fill system enters the building.

Degree of elevation = Angle at which the system is installed (from horizontal).

System shown with screener boot installed in-line; system may also be installed with the screener boot rotated 90 degrees.

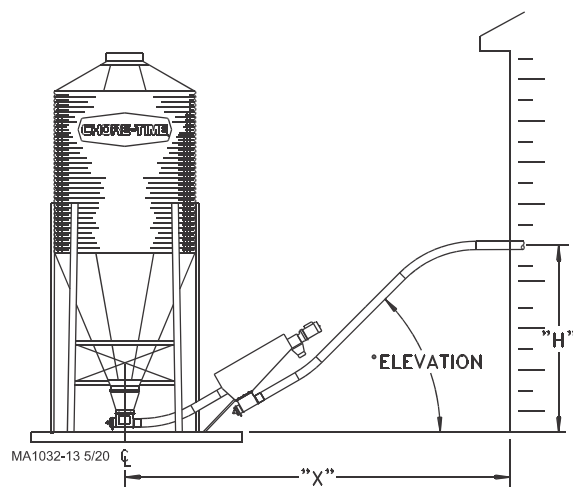

### 30° or Straight-Out Bin Boot with Feed Screener Boot Rotated 90°

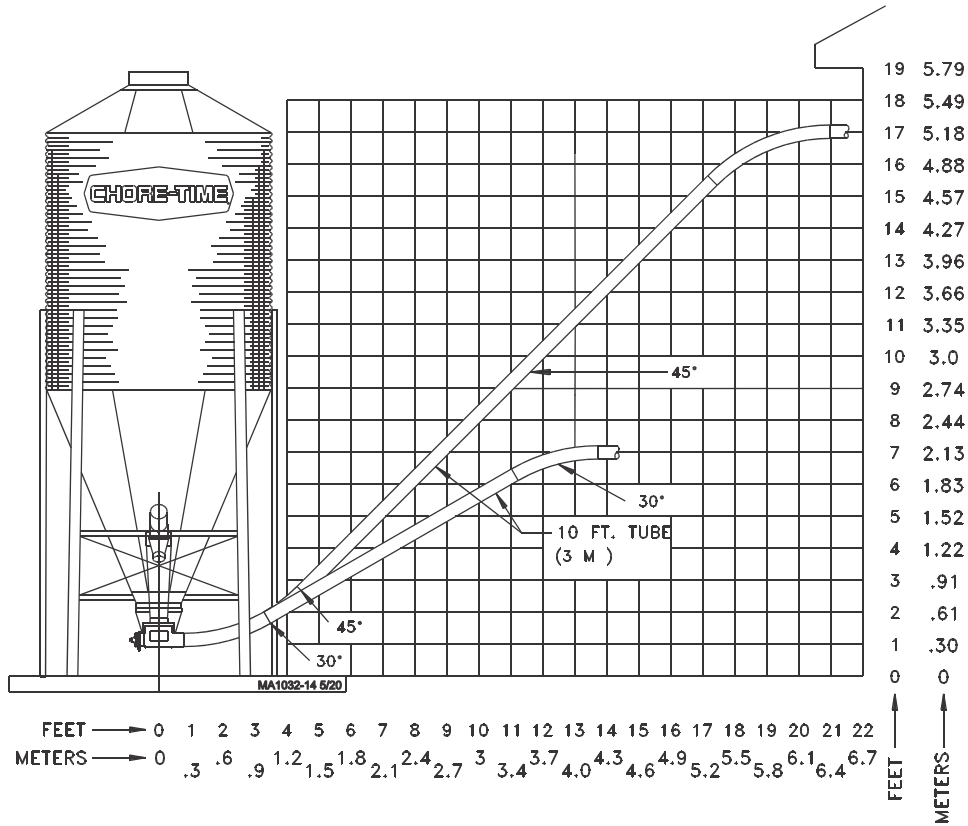

### 30° Bin Boot with Feed Screener

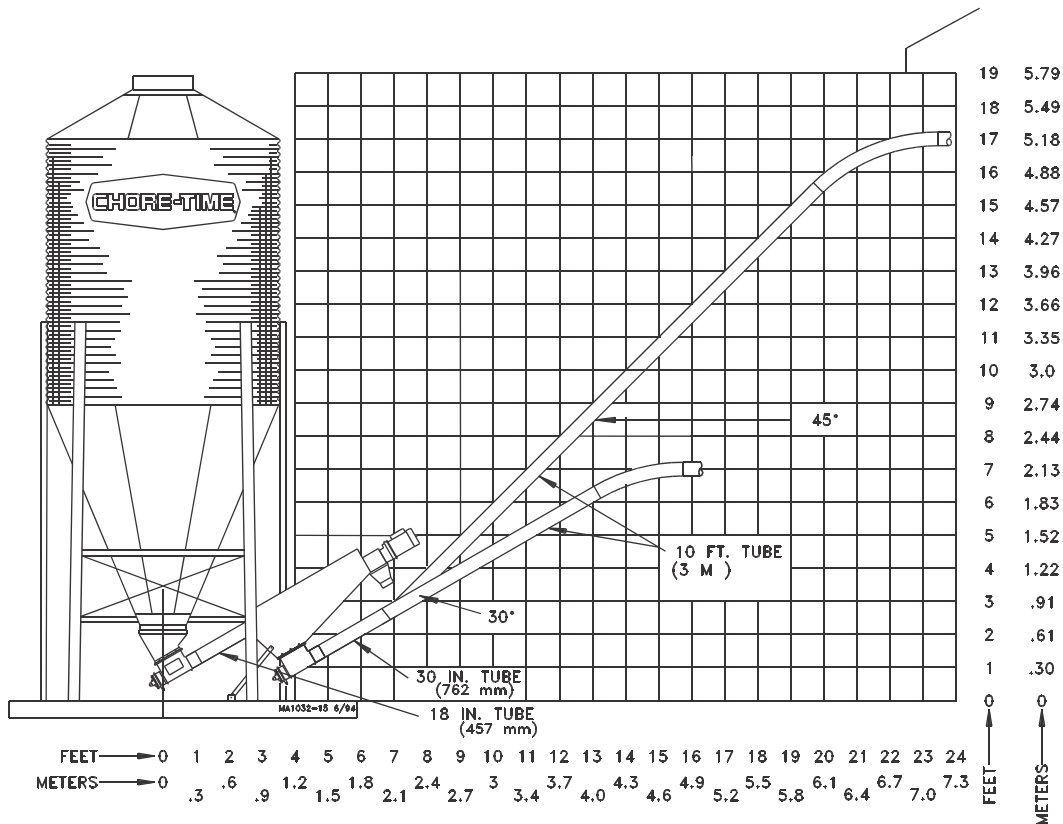



# Straight-Out Bin Boot with Feed Screener

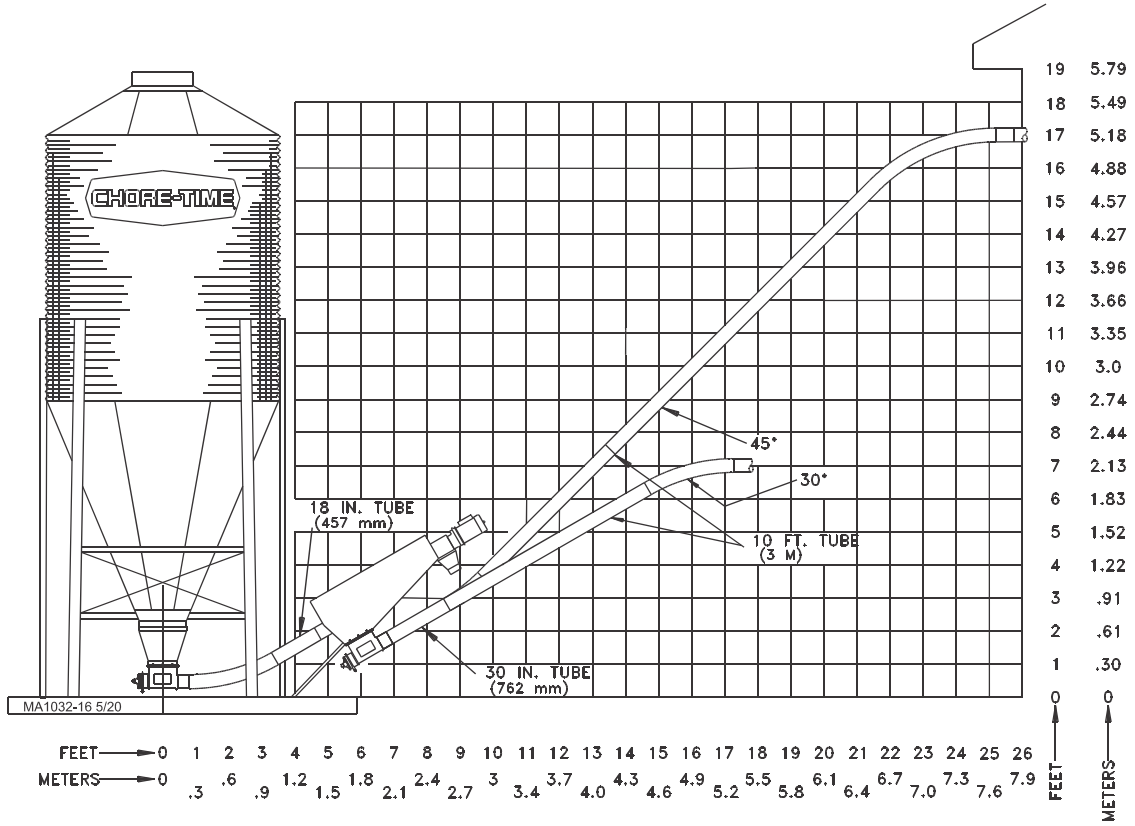

# Installation

## Bin Location

For easiest installation and most trouble-free operation, locate the feed bin directly in line with the FLEX-AUGER System. The layout charts on **Page 14** and **Page 17** provide some points of reference for bin placement according to the height at which the system enters the building. The 30 degree or straight-out boots combined with various elbow hookups offer a wide range of possibilities. The charts are only for reference. Modify and adjust elbows and tube sections as needed.

NOTE: Two 45 degree PVC elbows are standard with Model 108 FLEX-AUGER Delivery Systems. If additional elbows are required they must be ordered separately.

The bin collar is installed during bin assembly. Chore-Time bins have a welded collar. Bin Adapter Kits are available to modify existing bins so that the welded collar can be used. In addition, a Universal Adapter Plate is available to allow the FLEX-AUGER boot to be installed to other manufacturers' bins.

Tighten all bin-seal bolts from the nut side. This prevents cutting and "spinning out" of the plastic washer.

## Boot Installation

1. Insert the upper boot into the bin collar and turn it to line up with the direction that the auger line will go. The boot must be as far up into the opening as it will go. Use the holes in the ring for drilling guides and drill 11/32" (8.8 mm) holes in the upper rim of the boot. Attach the boot to the bin collar with the hardware provided. (See Figure 1.)

**IMPORTANT: Failure to install the hardware as shown in Figure 1 may cause breakage of the red boot body.**

2. Attach the transfer plate to the upper boot. Use truss head bin-seal bolts installed from the inside of the plate, with flat washers placed under the nuts.
3. Insert the slide into the transfer plate slot so that it is in its operating position before bolting the slide shield in place. Remove the paper backing from the sealing strip before fastening the slide shield to the transfer plate. Use two 5/16-18 x 3/4" hex head machine screws to secure the shield.
4. Bolt the lower boot to the transfer plate using four 5/16-18x3/4" hex head machine screws.
5. After the auger tubes and auger have been installed, attach the 6197 Clean-Out Cover Plate or the optional Proximity Boot Switch to the lower boot.

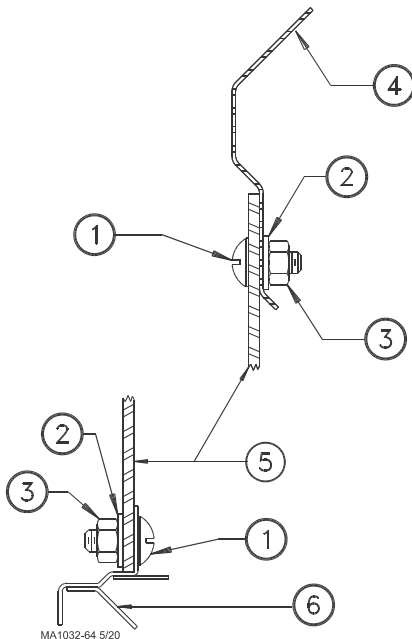

KEY	DESCRIPTION	PART NO.
1	5/16-18 X 3/4" Truss Hd. MS	7943-1
2	5/16" Nylon Washer	7946
3	5/16-18 Nylon Hex Nut	7945
4	Hopper Collar	-
5	Boot Body	-
6	Transfer Plate	-

Figure 1.Boot Installation Diagram

## Auger Tube Installation

The FLEX-AUGER Delivery System includes two 45 degree elbows as standard equipment. These elbows are used to make up the sloping portion of the auger line at the feed bin, and elsewhere in the system if necessary. If additional elbows are required they should be ordered separately. **Figure 2** shows how the elbow can be cut into shorter sections.

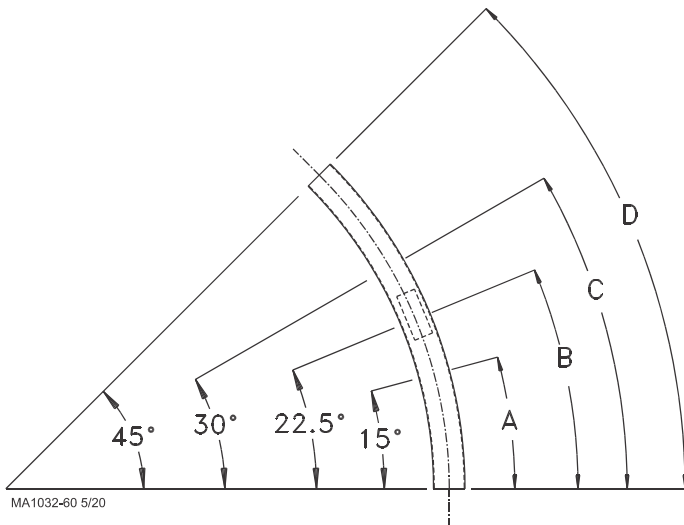

MA1032-60 5/20

Dimension	PVC	Steel
"A"	16.8" (43 cm)	16.3" (41 cm)
"B"	25.2" (64 cm)	24.4" (62 cm)
"C"	33.6" (85 cm)	32.5" (83 cm)
"D"	50.3" (128 cm)	48.8" (124 cm)

**Figure 2.PVC Elbow Cutting Guidelines**

**Note:** All measurements are along the outside edge of the elbow.  
**Note:** PVC elbows are belled. Dimensions shown do not include bell.

1. Determine where the entrance hole for the auger tube must be located on the building and cut it.
2. If necessary, cut the elbow used where the auger enters the building. Slide the seal ring and neoprene seal over the straight end of the elbow and place it in the hole cut in the building, with the belled end outside the building. (See **Figure 3.**) Clamp the belled end of the second elbow on the outlet end of the boot on the feed bin.
3. Place the straight end of a tube section inside the belled end of the elbow in the building. Hold the straight section of auger tube so that it touches the elbow on the boot. Mark the spot where the tube touches the boot elbow and cut the elbow at that point.
4. Place the belled end of the auger tube over the end of the elbow just cut, and hold the tube against the top elbow. Mark and cut the straight auger tube so that it will fit between the two elbows.

**Remember to cut the auger tube long enough to fit inside the belled end of the elbow in the building.**

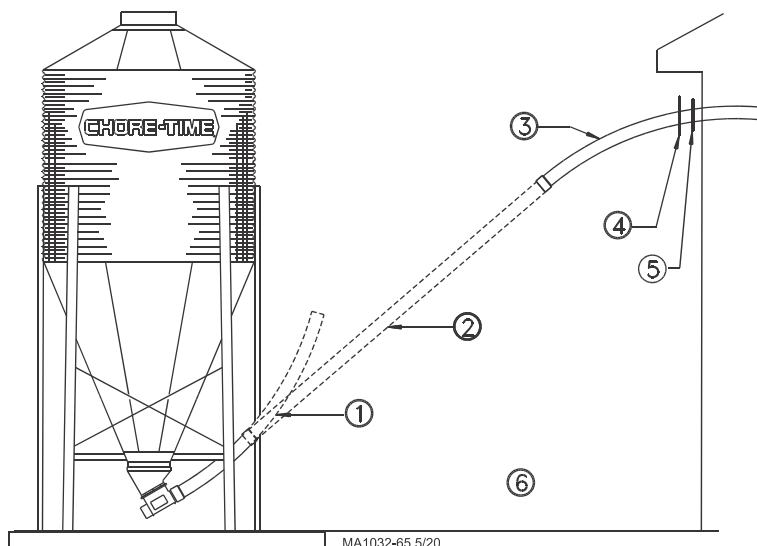

MA1032-65 5/20

**Figure 3.Elbow Installation outside the building**

Key	Description
1	45° Elbow
2	Auger Tube
3	45° Elbow
4	Seal Ring
5	Neoprene Seal
6	Note: Belled end of elbows and auger tubes should be towards boot.

**Note: In some installations it may be possible to eliminate the elbow on the boot, using only a straight auger tube and one elbow where the auger tube enters the building.**

5. Dry-fit all parts. When satisfied that elbows and tubes fit together smoothly, glue with PVC cement according to the instructions on cement container and/or on **Page 49** of this manual.
6. ALL TUBE JOINTS EXPOSED TO MOISTURE AND WEATHER MUST BE SEALED OR CAULKED TO WATERPROOF THEM IN ADDITION TO CEMENTING OR CLAMPING THE JOINT.
7. If there are more than 15 feet (4.5 meters) of auger tube between the boot and the building, provide additional support for the tubes so that the boot does not carry the weight of the auger. Extra support can be achieved with cables or chain fastened to the bin legs and the auger tube.
8. Locate and cut the outlet holes as required and specified in the instructions on **Page 20**.
9. Slide (2) Outlet Insert Rings onto the pipe at each outlet hole location.  
 Each Outlet Assembly is shipped with Insert Rings for both steel and PVC pipes.  
 The 3/8" (10 mm) thick rings are for steel tube systems. The 1/4" (6 mm) thick rings are for PVC tube systems. Be sure to use the appropriate Insert Rings for your system.
10. Install the remaining tubes in the system.  
 The PVC auger tubes should be fastened together using PVC cement.  
 Model 108 Tube connectors should be used to connect steel auger tubes.

### Outlet Drop Installation

Cut the outlet hole in the auger tube. A sabre saw or hacksaw is handy for making the cuts when total feed dropout is desired. (See **Figure 4.**) Use a file to remove burrs from opening.

Note: For total feed drop out, outlet holes should be 5-3/8" (137 mm). If some feed carry over is required, outlet holes should be 3-1/2" (90 mm).

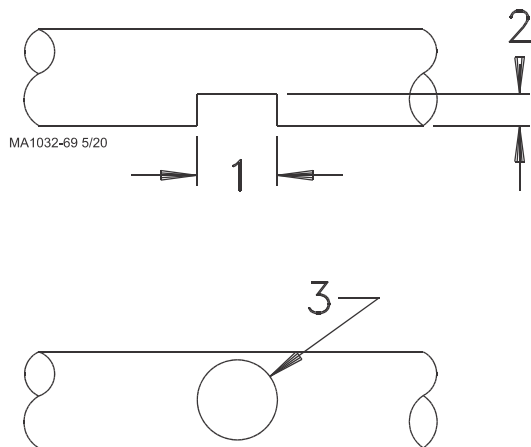

Key	Description
1	5-3/8" (137 mm)
2	2" (50 mm)
3	3-1/2" (90 mm)

**Figure 4. Outlet Holes provide total or partial feed dropout**

1. Wrap the rotary slide around the auger tube. POSITION SLIDES IN SAME DIRECTION FOR ALL DROPS SO THAT THE SLIDES WILL ALL OPERATE THE SAME WHEN ROPES ARE PULLED.
2. Thread the rope through the ends of the rotary slide.
3. Tie the ends of the rotary slide together so that the ends of the rope are the same length.
4. Open rope guide holes molded into the drop halves. Use a 3/16" (5 mm) drill bit and power drill to make a good hole for the rope.

NOTE: DO NOT OPEN THESE HOLES IF THE ROTARY SLIDE WILL NOT BE INSTALLED.

5. Thread the rope ends through the guide holes in the drop halves.
6. Position drop halves over the rotary slide and fasten the two halves together using hardware provided. (See **Figure 5.**)  
Insert Rings are provided for both Steel Systems (Thicker Rings) and PVC Systems (Thinner Rings). Slide the Insert Rings (with Flanges out) into position between the outlet halves to serve as spacers.

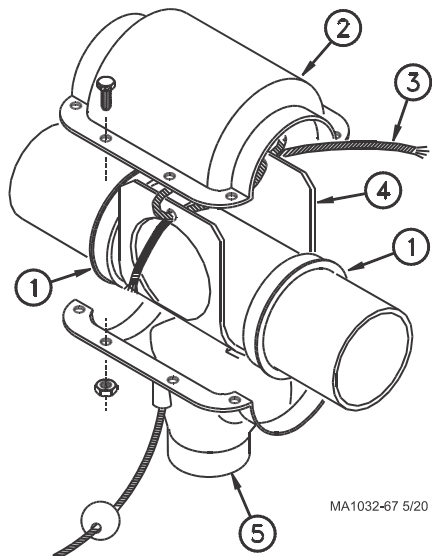

Key	Description
1	Insert (For Steel or PVC System)
2	Top Half
3	Rope
4	Rotary Slide
5	Bottom Half w/Spout

**Figure 5. Model 108 Outlet Drop Assembly**

7. Test the operation of the rotary slide by pulling on the ends of the rope. Be sure the outlet drop is centered over the outlet hole, then move the rotary slide to the open position (check by looking up through the drop opening) and mark the short end of the rope where it goes through the guide hole. Tie a knot in the rope at the marked spot to act as a stop for the rotary slide.
8. Install green and red indicator balls on the ends of the rope. Tie knots in the rope to hold the balls in place. Use the green ball on the rope used to open the outlet drop. Use the red ball on the rope used to close the drop. This will indicate if the Outlet Drop is open or closed.
9. Dab PVC cement around the auger tube to prevent the drop from shifting on the tube.
10. Two screws are supplied for use in the bottom of the drop to attach a drop tube to the system.

## Supporting the System Inside the Building

Support the auger tubing with chain and "S" hooks every 5 feet (1.5 m). Steel tube systems require support every 10 feet (3 m). The system should be restrained from swinging by using chain and "S" hooks to brace the auger tube, as shown in **Figure 6**, every 20 feet (6 m). This is especially critical in UltraKARTM Feedkar applications where hopper cars contact gate valves.

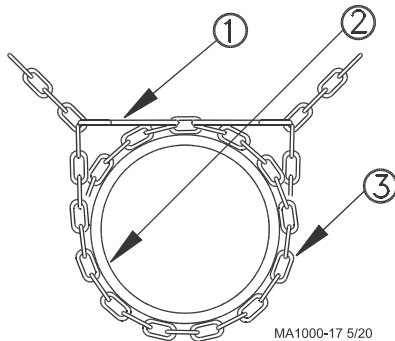

Key	Description
1	"S" Hook
2	Auger Tube
3	Chain

**Figure 6. Supporting the Auger Tubes**

Horizontal elbows need to be supported in at least two places. Chain, screw hooks, and "S" hooks are supplied as a suspension kit for supporting the equipment. Keep the line as level and straight as possible.

If Drop Feeders, Extension Hoppers, Outlet Drops with long angled Drop Tubes, or other loads are imposed on the system, extra support will be required.

Power Units require extra support to resist the twisting encountered when the motor starts and stops. Use all of the "ears" on the gearhead as well as the suspension point provided on the 6500 Control Unit Box to support the Power Unit.

Adequate chain and "S" hooks are provided with each system to properly support it. Other means of supporting the system are permissible as long as the system receives the correct support and the auger tube is not dented or flattened.

When the auger tube passes through a side wall or partition, especially where it enters the building, the opening should be made large enough so the auger tube can be supported without resting on the wall. If the auger tube rests on the wall or partition, the auger tube may flatten out or become kinked--causing excessive wear. (See **Figure 7**.)

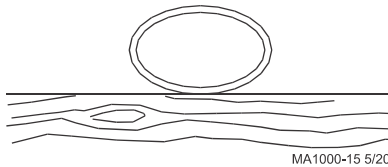

Auger tube kinked because the supports are not high enough to keep the weight of the auger tube off the wall.

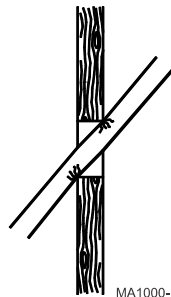

Tube pinched because auger tube is not in line with hole in wall.

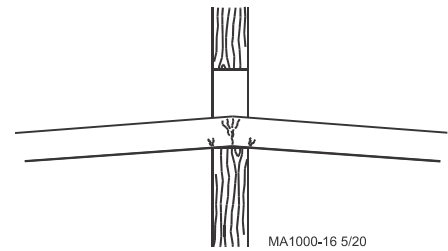

Auger tube flattened because supports are too far away from each side of the wall.

**Figure 7. Incorrectly Supporting the Auger Tubes**

## Supporting the System Outside the Building

Some systems require additional support to avoid sagging auger tubes. This support must be adequate to support the weight of the auger tubes filled with feed. Special attention should be given to avoid excessive pressure from the auger being transferred to boot. Chain or cable suspended from the bin or building will not provide adequate support for these systems.

Some common systems are shown in **Figure 8** through **Figure 12**, with the recommended supports.

**Note:** Supports must be designed to prevent (weight) loads from being transferred back onto the boot.

**REMEMBER:** The auger tubes must be supported every 4-5 feet (1.2 to 1.5 m) for PVC systems and every 10 feet (3 m) for steel systems.

### Screeners

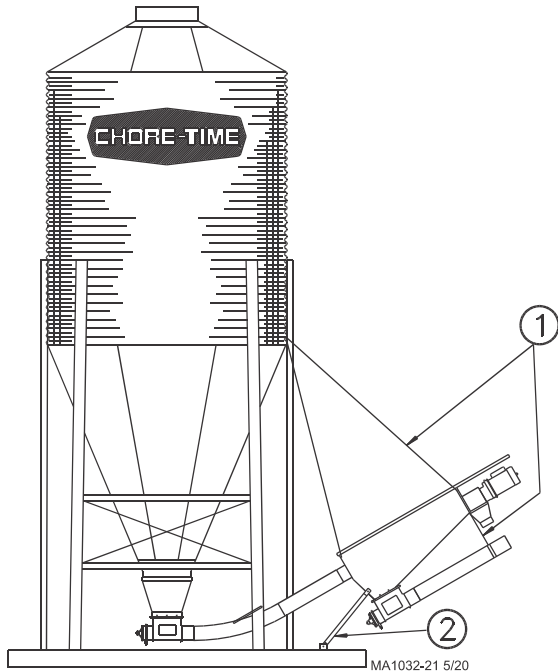

Key	Description
1	5' (1.5 m) for PVC Systems 10' (3 m) for Steel Systems
2	Screener Brace.

Figure 8.Screener Support

### High Rise Auger Tube Support

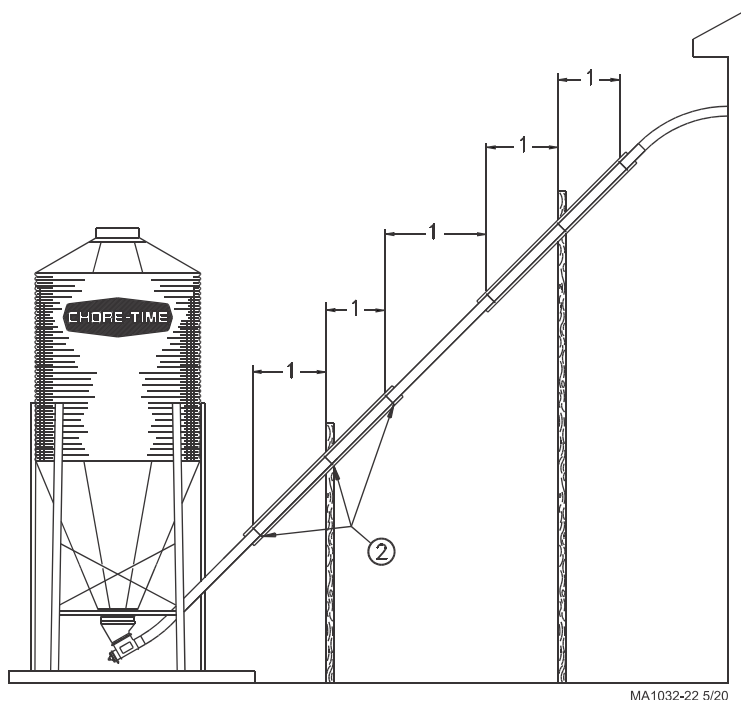

Key	Description
1	5' (1.5 m) for PVC Systems 10' (3 m) for Steel Systems
2	Place clamps here.

Figure 9.High Rise Auger Tube Support

### Long Elevated Systems

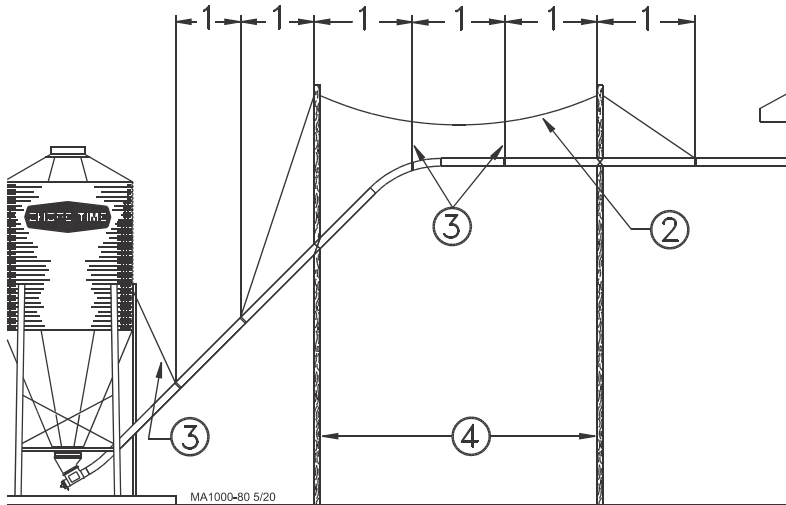

Key	Description
1	5' (1.5 m) for PVC Systems 10' (3 m) for Steel Systems
2	Master Cable
3	Chain or Cable
4	20' (6 m) Maximum

**Figure 10. Long Elevated Systems**

### Bin to Bin Support Systems

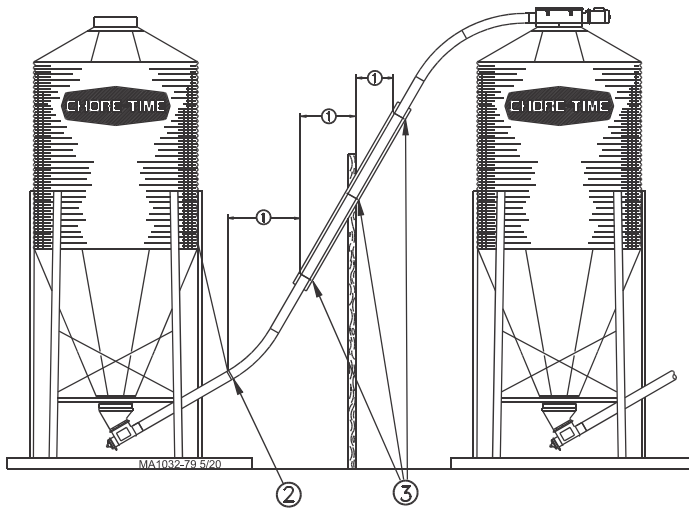

Key	Description
1	5' (1.5 m) for PVC Systems 10' (3 m) for Steel Systems
2	Chain or Cable
3	Place clamps here.

**Figure 11. Bin to Bin Support**

### Straight-Through Tandem Systems

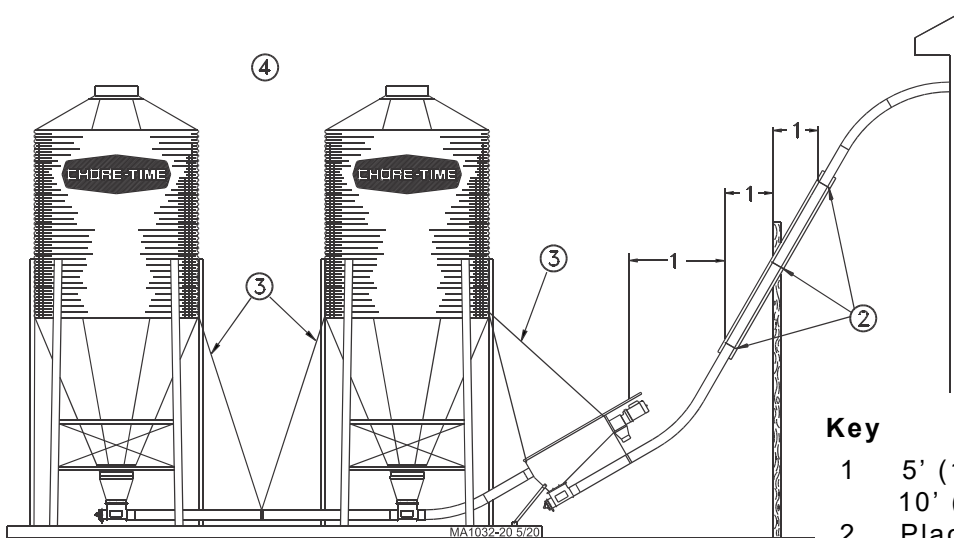

Key	Description
1	5' (1.5 m) for PVC Systems 10' (3 m) for Steel Systems
2	Place clamps here.
3	Chain or Cable
4	Tandem Feed Bins

**Figure 12. Straight-Through Tandem Systems**



## Control Unit & Power Unit Installation

1. Attach the Tube Anchor to the end of the Control Unit. Place a flat washer on each bolt that fastens the Tube Anchor to the Control Unit. (See Figure 13.)

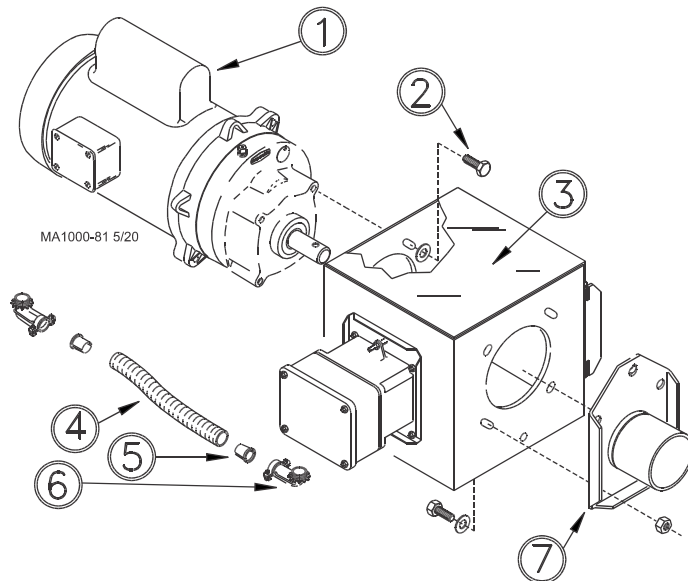

Key	Description
1	Power Unit
2	5/16-18 Screws
3	Control Unit
4	Flexible Cable
5	Anti-Short Bushing
6	90 Degree Connector
7	Tube Anchor

Figure 13. Control Unit & Power Unit Installation

2. Attach the power unit to the control unit using the 5/16-18 machine screws installed on the face of the gearhead and the flat washers packed with the control.
- 3-Phase Applications: Power Units/Control Units do not include all the electrical components shown. Components must be purchased locally to match local and national electrical codes. Skip to step 4.  
1-Phase Application: Connect the electrical wires on the power unit to the control unit. The power unit is shipped with the electrical connectors attached. Flex cable is shipped with the control unit.
  - a) Install a red plastic anti-short bushing in one end of the flex cable. Push the anti-short bushing into the end of the cable so that the wide lip covers the edge of the metal to protect the wire insulation.
  - b) Push the power unit wires through the flex cable starting in the end with the anti-short bushing. Be careful not to damage the insulation on the wires.
  - c) Clamp the end of the flex cable in the 90 degree connector on the motor. Be sure the anti-short bushing is still in place.
  - d) Install the anti-short bushing supplied with the control unit in the free end of the flex cable.
  - e) Run the motor wires through the 90 degree connector supplied with the control unit and clamp the flex cable in the connector.
  - f) Attach the 90 degree connector to the control unit housing.
  - g) Attach the insulated motor wires to the terminal block in the control housing: one wire to terminal three (3) and one wire to terminal four (4). Attach the bare grounding wire to one of the green colored screws provided for bonding the grounding wires.
4. Place a tube clamp on the Tube Anchor and connect the Control Unit/Power Unit assembly to the end of the FLEX-AUGER tube.

**Note for steel systems:** The Tube Insert must be inserted in the Tube Anchor Weldment.

**Note:** The switch in the control unit is a safety back-up switch in case the feed level switch fails to shut off the system. DO NOT use the safety switch to control the FLEX-AUGER System, as feed will bridge in the control, and the motor overload will trip.

5. Support the Power Unit and Control Unit securely. Points are provided at the gearhead and the tube anchor for hanging the equipment from the rafters with chain and "S" hooks supplied with the delivery system. (See **Figure 14.**)

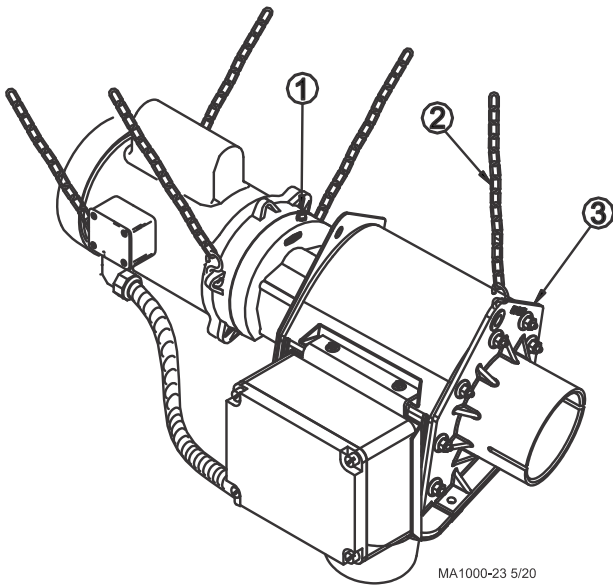

Key	Description
1	Power Unit
2	5/16-18 Screws
3	Control Unit
4	Flexible Cable
5	Anti-Short Bushing
6	90 Degree Connector
7	Tube Anchor

**Figure 14. Control Unit & Power Unit Suspension**

**NOTE:** Other ways of supporting the delivery system can be used where it is practical, as long as the supports do not allow the equipment sag or do not make flat spots in the auger tubes.

6. Install the Driver Assembly on the power unit shaft. Start the socket headed screws but leave the anchor block loose enough to slip the auger into it.
7. Replace the plastic shipping plug in the gearhead with the vent plug provided. Discard the Plastic Shipping Plug.

**NOTE:** Unit must be protected from the elements. Unit as installed is not protected from direct rain or snow.

### Belt Drive Control Unit Installation

The Belt Drive Control Unit installation is much the same as the direct drive unit. Mount the Belt Drive Adapter and Motor to the control unit, then proceed with installation to the auger tube as described in this manual. **Page 26** can be used as an assembly guide for the Belt Drive Control Unit.

### Auger Installation

Use extreme caution when working with the auger. The auger is under tension and may spring causing injury. Always wear protective clothing and protective glasses when working with the auger.

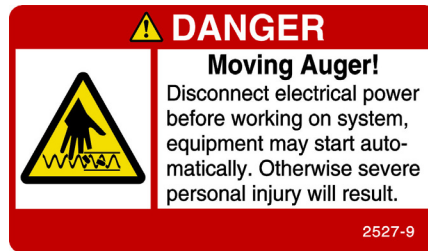

Handle the FLEX-AUGER carefully. Dropping the rolls of auger may cause the auger to kink. Do not install an auger that has a sharp kink in it. The kink will cause the auger to wear a hole in the tube at that spot. If the kink cannot be straightened with pliers, the kink must be cut out and the auger brazed back together. Refer to the "Auger Brazing" section in this manual for the correct brazing procedure.

1. Beginning at the boot, push the auger into the auger tube through the rear of the boot until the auger reaches the control unit end of the line.

**Caution!** Use extreme caution when pushing the auger into the auger tubes. Keep your hands away from the end of the Boot to avoid injury.

2. Attach the auger to the Driver Assembly by rotating the driver and threading the auger through the Anchor Clamp.
3. Rotate the auger so that it is fully engaged on the Driver Assembly. Tighten the screws securely to clamp the auger to the Driver Assembly. (See Figure 15.) Attach the drop tube and install the slide cover on the control unit.
4. Pull on the loose end of the auger at the boot once or twice until it begins to stretch, then release it slowly. This will bring the auger to its natural length.

**Note:** For ease of cutting, measure and mark the auger at the point where it is to be cut. Then, pull the auger an additional 6-8" (150-200 mm) and use locking pliers to clamp the auger while you cut it.

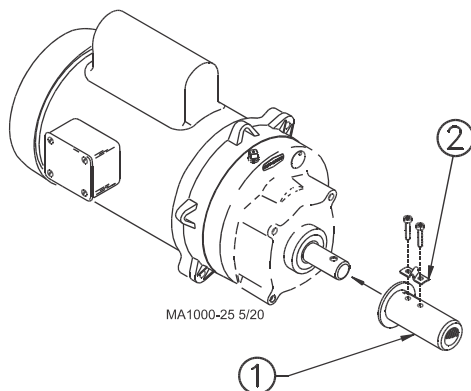

Key	Description
1	Model 108 Driver Assembly
2	Anchor Clamp

**Figure 15. Model 108 Auger Installation**

**IMPORTANT:** Stretch the auger 8 inches (200 mm) for every 50 feet (15.2 m) of length. Example: For a 150 ft. (45 m) system the auger should be cut 24 inches (610 mm) shorter than its natural length. Measure the amount of stretch from the rear edge of the boot and cut the auger at that point.

5. **Figure 16** shows the proper assembly of the Model 108 boot components. Insert the Anchor Shaft into the auger until the auger touches the anchor flange. The auger must be threaded onto the Boot Anchor Assembly, through the clamp pin. Use a 5/16" open-end wrench to tighten the clamp pin setscrew on the auger.
6. **CAREFULLY** remove the locking pliers while holding on to the Anchor and Bearing Assembly and auger securely.
7. **CAREFULLY** allow auger to draw the Anchor and Bearing Assembly back into the Lower Boot. **DO NOT ALLOW THE BEARING TO BE SLAMMED BACK INTO THE BOOT.**
8. Attach the Anchor and Bearing Assembly to the Boot, using tube clamp provided.
9. Place the cannonball in the boot.

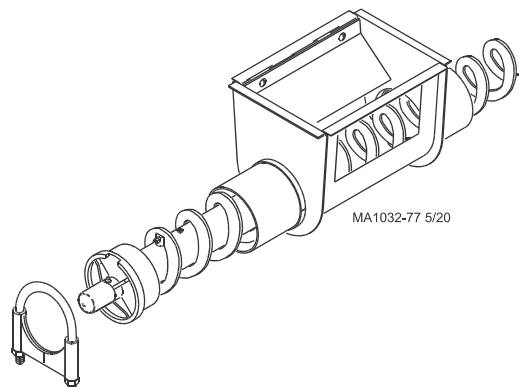

**Figure 16. Model 108 Anchor and Bearing Installation**

### Cover Plate Installation

1. Loosen Hex Nuts to the end of studs.
2. Start lower side of cover plate (**Item 2**) in boot opening.
3. Slide the cover plate up as far as possible so that plate catches top of boot opening.
4. Hold the cover securely while tightening the Hex Nuts.

**Important! DO NOT** replaced lock nuts! Replacing them will violate CE compliance, & will void warranty and may cause personal injury or even death!

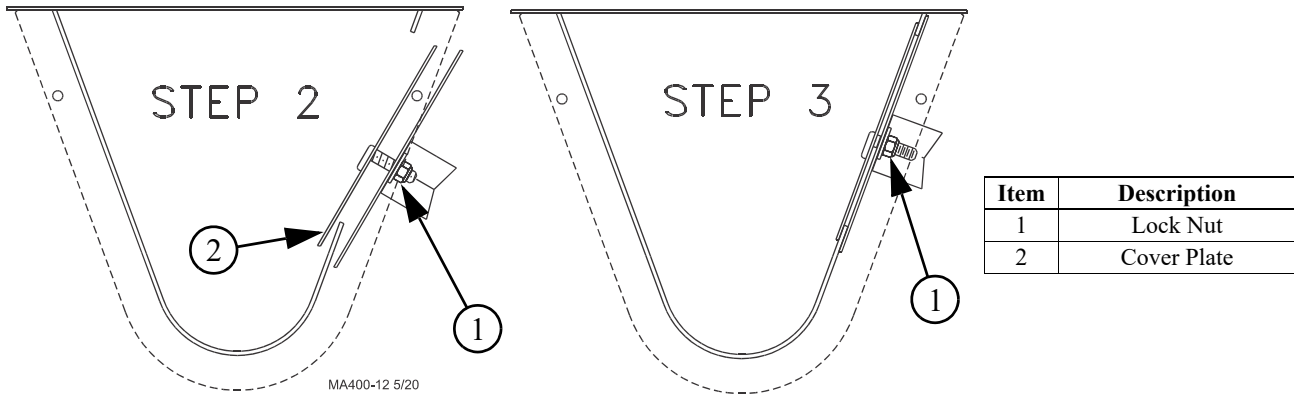

Figure 17. Cover Plate Installation

### Auger Brazing

If the auger needs to be spliced or lengthened, locate the brazed joint closer to the power unit to minimize feed flow restriction in the line.

To align the auger for brazing, lay it in an 18” (46 cm) piece angle iron and clamp securely.

Rotate the auger to allow both the inside and outside edges of the augers to be brazed.

Butt the ends of the auger against each other. **DO NOT SCREW ONE AUGER INSIDE THE OTHER**--This restricts the feed flow.

Lap the augers approximately 2” (50 mm), as shown in **Figure 18**.

A bronze, flux-coated rod is recommended. The joint should be well filled and smooth so that it does not wear against the tube. Allow the joint to air cool.

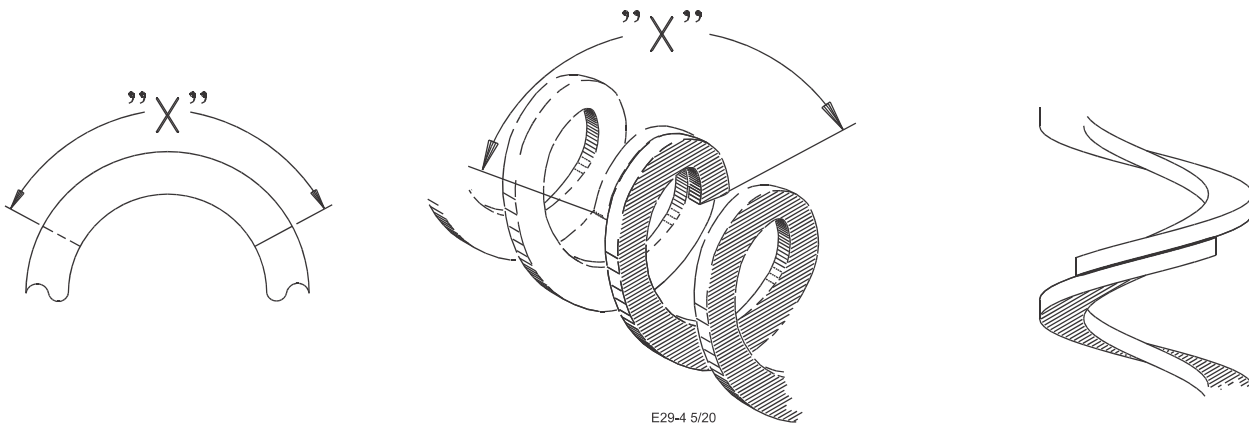
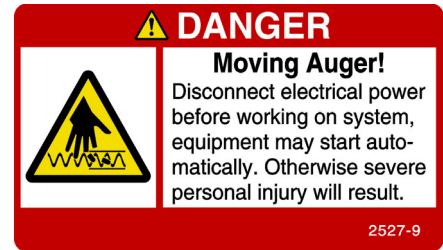

Key	Description
1	2" [50 mm]

Figure 18. Cover Plate Installation

File the auger edges, as shown in **Figure 19**, to avoid damage to the auger tubes. Also, file off any brazing that extended beyond the outside radius of the auger flightings.

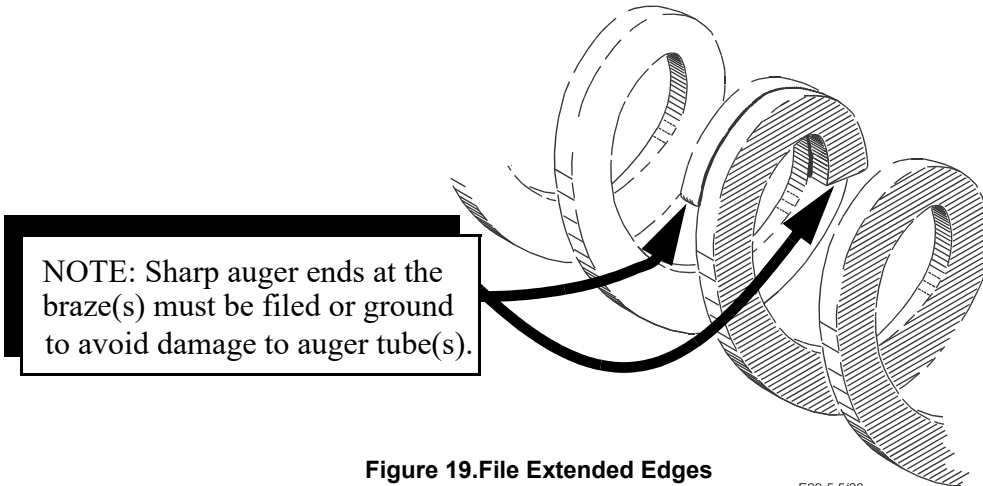

**NOTE:** Sharp auger ends at the braze(s) must be filed or ground to avoid damage to auger tube(s).

**Figure 19.**File Extended Edges

E29-5 5/20

### Restrictor Adjustment

**NOTE:** The Model 108 feed delivery capacities may be increased by reducing the length of the Restrictor.

**DO NOT ADJUST THE RESTRICTOR UNTIL THE SYSTEM HAS BEEN IN OPERATION AND THE SYSTEM IS BROKEN IN.**

**NOTE:** Feed delivery capacities are based on 40 lbs/ ft.3 (640 kg/m<sup>3</sup>) feed density. Systems using lighter weight feeds may not be able to achieve the maximum capacities listed.

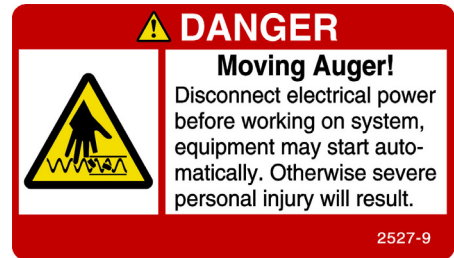

**NOTE:** Always refer to the motor amperage nameplate when increasing the feed flow capacity. Exceeding the nameplate amperage may result in nuisance motor overload tripping and/or damage to the system.

1. Loosen the tube clamp on the back of the Lower Boot to remove the Anchor and Bearing Assembly from the boot.
2. Use extreme caution when working with the auger under tension. Springing auger can cause personal injury. Pull enough of the auger out of the auger tube to allow the Restrictor Tube to be cut. Use locking pliers to hold the auger outside the boot.
3. Use a hacksaw to cut 1" (25 mm) at a time off the end of the Restrictor Tube to increase feed flow. (See **Figure 20.**)
4. **CAREFULLY** remove the locking pliers while holding on to the Anchor and Bearing Assembly and auger securely.
5. **CAREFULLY** allow the auger to draw the Anchor and Bearing Assembly back into the Lower Boot. **DO NOT ALLOW THE BEARING TO BE SLAMMED BACK INTO THE BOOT.**

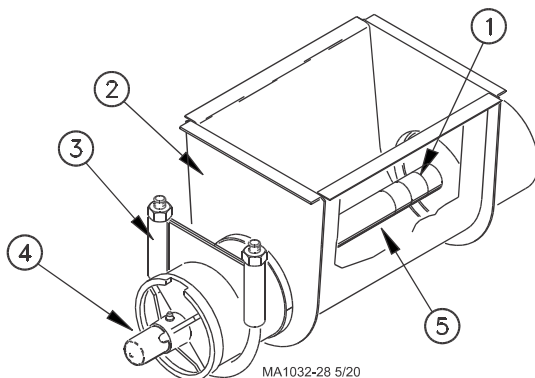

MA1032-28 5/20

**Key Description**

- |   |  |
|---|--|
| 1 | Restrictor Tube  |
| 2 | Lower Boot   |
| 3 | Tube Clamp   |
| 4 | Anchor and Bearing Ass'y   |
| 5 | Cut off approximately 1" (25 mm) of the Restrictor Tube to increase feed flow. Repeat as required. |

**Figure 20.**File Extended Edges

## Feed Level Control Installation

The Hopper Level Control (or Drop Tube Switch) is installed in the feed hopper (or on the drop tube over the feeder) at the power unit end of the line. This switch stops the FLEX-AUGER Feed Delivery System when the last feeder is full. Install the hopper level control or drop tube switch according to instructions shipped with the unit. Wire the switch into the system as specified in the appropriate wiring diagram in this manual.

## Types of Boot Installations

### Straight-Through Tandem Boot Installation

The Straight-Through Tandem Boots allow a single auger to remove feed from two separate feed bins. Feed should only be drawn from one bin at a time.

Boot Baffles are required and included with the Straight-Out Boot Assembly.

Model 108 Straight-Through Tandem Systems do not use Feed Restrictors.

1. Install boots on both feed bins. Be sure the outlets on the boots are in line with the slotted tube anchors facing in the direction the auger line will go. **Figure 21** shows a typical Straight-Through Tandem System.

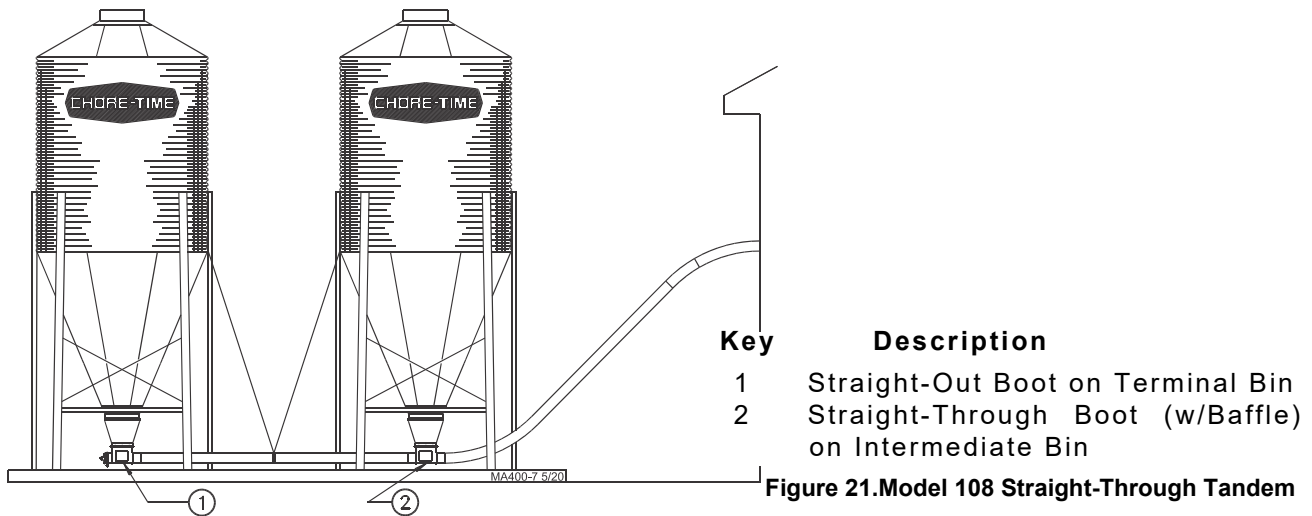

### PVC Straight-Through Tandem

2. Place an Insert in the belled end of the connecting auger tube. The Insert fits directly over the outlet end of the Terminal Boot.

Cut the straight end of the auger tube even with the stub tube on the Intermediate Boot.

Slide an Insert into the end of the auger tube and over the inlet end of the intermediate boot.

Secure this joint using a Tube Coupler and clamp.

Place an Insert in the belled end of the Elbow before inserting over the outlet end of the Intermediate Boot.

Install tube clamps as shown to secure the boot components in place.

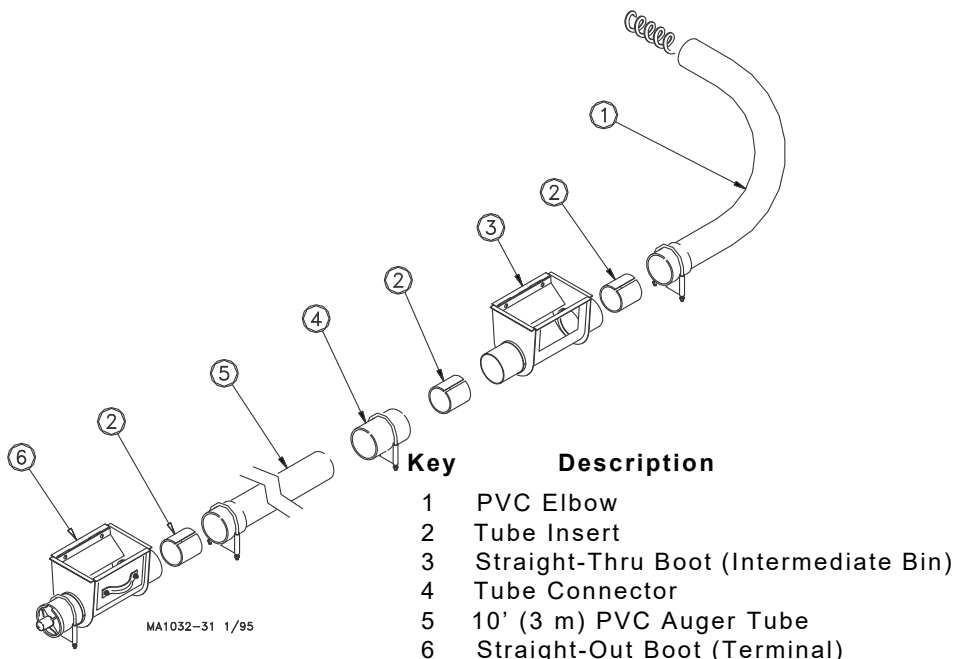

### Steel Straight-Through Tandem

1. Steel Model 108 FLEX-AUGER systems. (See Figure 23.)

Slide the belled end of the pipe over the outlet end of the Straight-Out Boot.

Cut the straight end of the auger tube even with the inlet end of the Intermediate Boot. Secure this joint using a Connector and clamps.

Slide the belled end of the Elbow over the outlet end of the Straight-Thru Boot. Secure in place using a Tube Coupler and clamps.

2. Install the remaining auger tubes in the system. Remember to caulk all tube joints exposed to the weather or moisture.

3. Install the auger and Anchor and Bearing Assembly as specified in the installation section of the standard Model 108 Flex-Auger system.

Stretch the auger in the same way you normally would for the standard installation (8 inches per 50 feet or 200 mm per 15 m) and cut it even with the rear of the straight-out boot.

4. Use a tube clamp to secure the bearing to the boot.

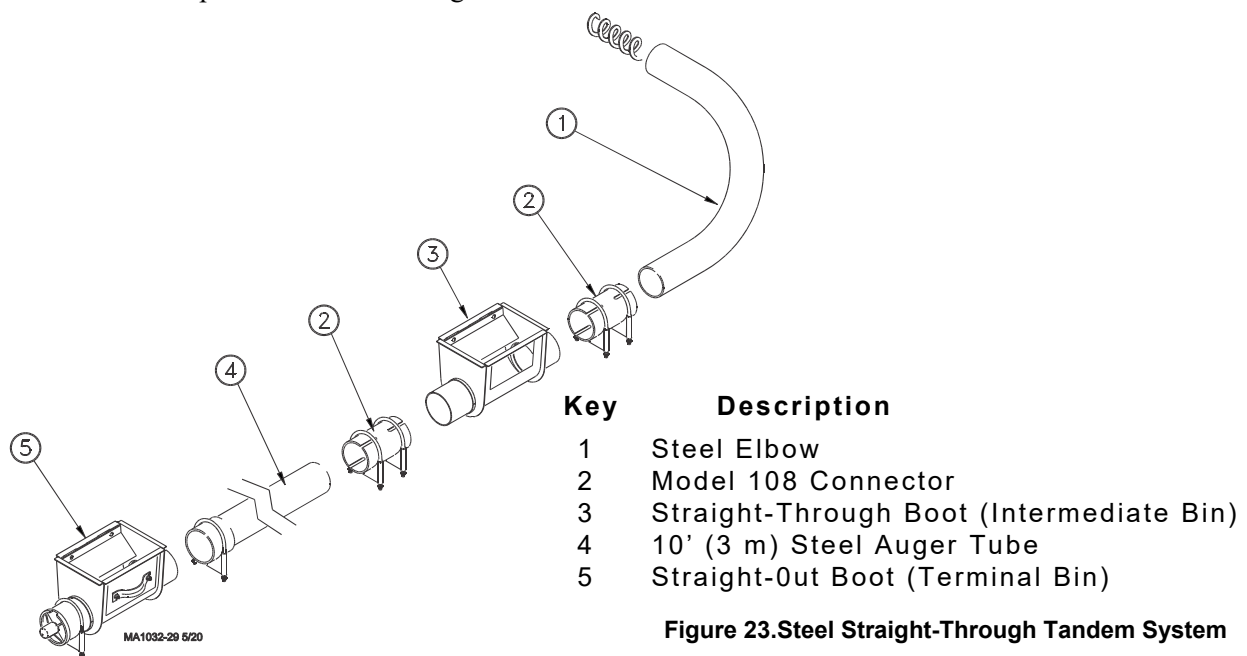

**Related Instruction Manuals**

**Instruction No.**

Extended Length System Manual (Model 108)

MA1102

AGRI-TIME Digital Time Clock Manual

MF1115

Proximity Level Switch

MA1193

Upper Boot Switch Instruction

MA1293

# Wiring

## Electrical Component Location Diagrams

### Single Boot Systems using a Hopper Level Control

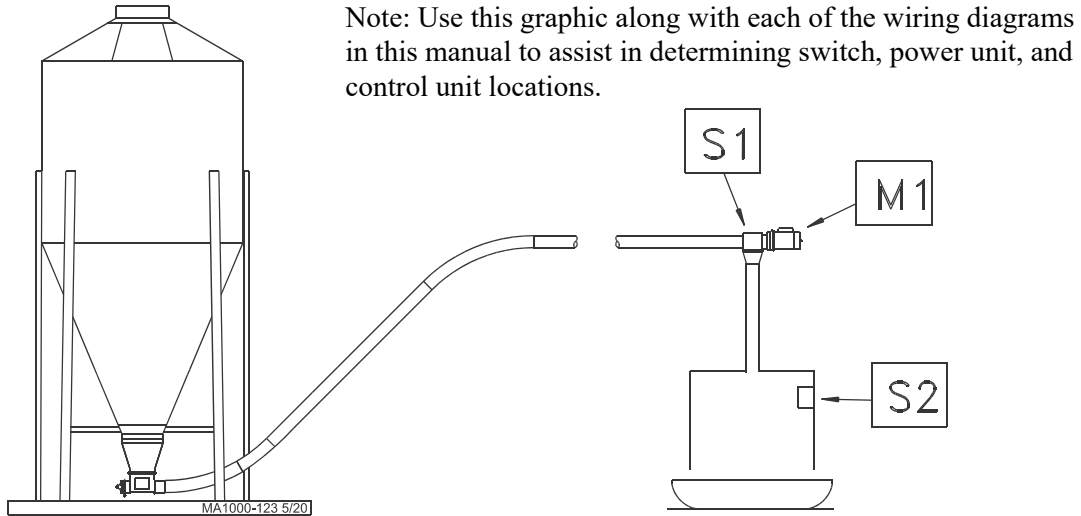

### Model 108 Systems using a Hopper Level Control Switch (1 H.P. or smaller - Single Phase)

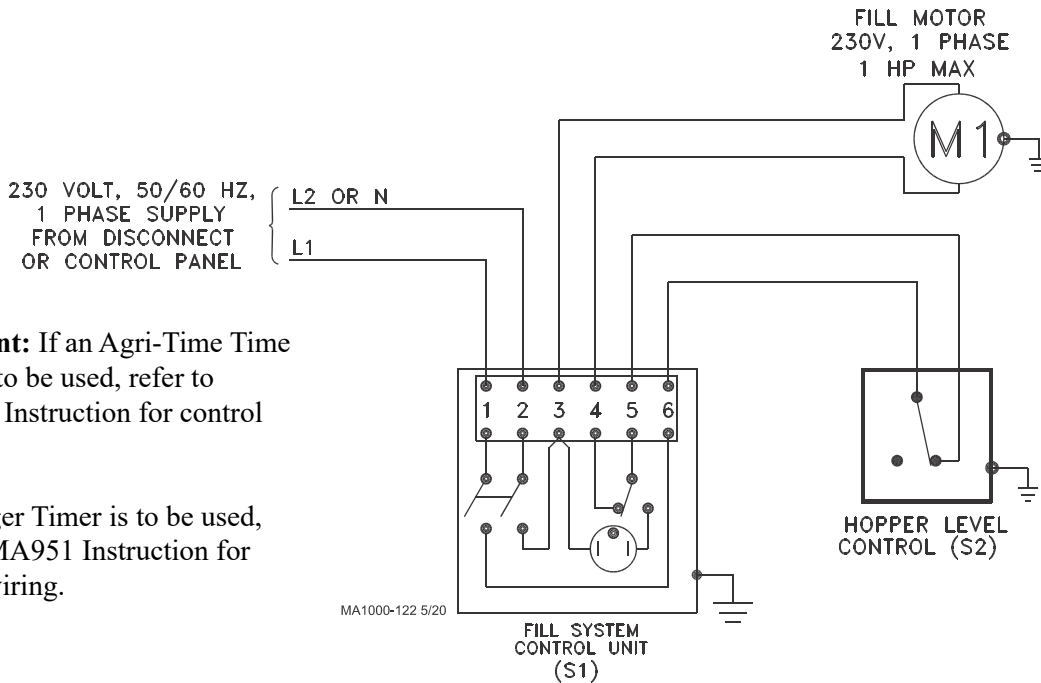

**Important:** If an Agri-Time Time Clock is to be used, refer to MA1061 Instruction for control wiring.

If an Auger Timer is to be used, refer to MA951 Instruction for control wiring.

**Important:** If system is to be controlled by a Proximity Drop Tube Switch, refer to MA1044 Instruction for switch wiring.

If the system is to be controlled by a mechanical Drop Tube Switch, refer to MA1099 Instruction for switch wiring.



### Model 108 Systems using a Hopper Level Control (1-1/2 H.P. or larger - Three Phase)

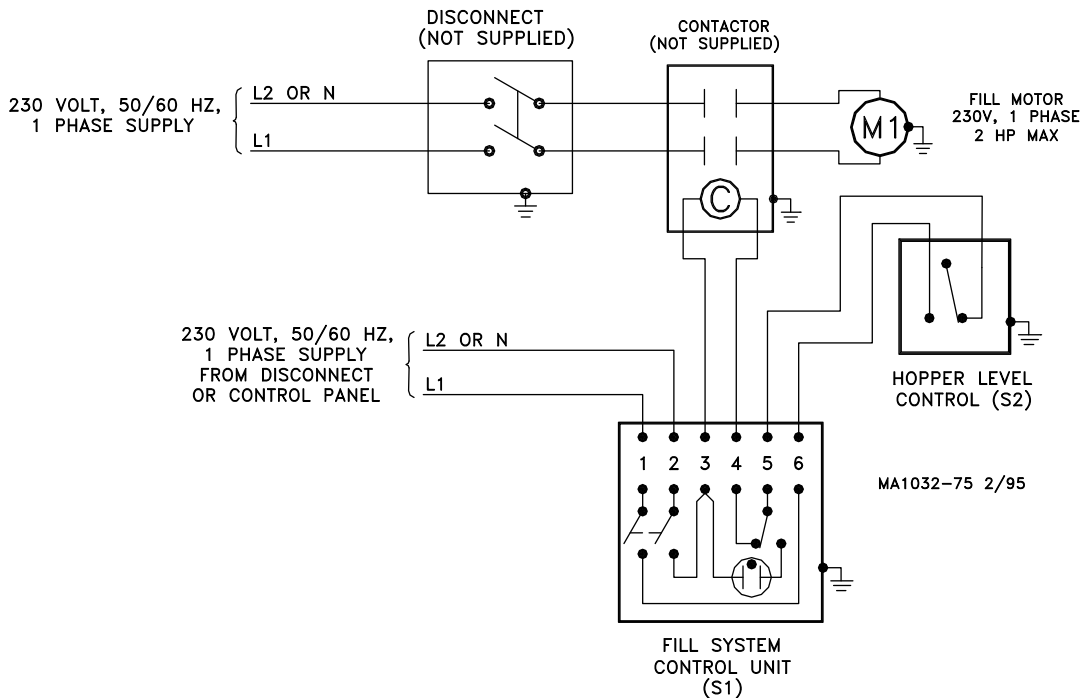

### Model 108 Systems using a Hopper Level Control (Three Phase)

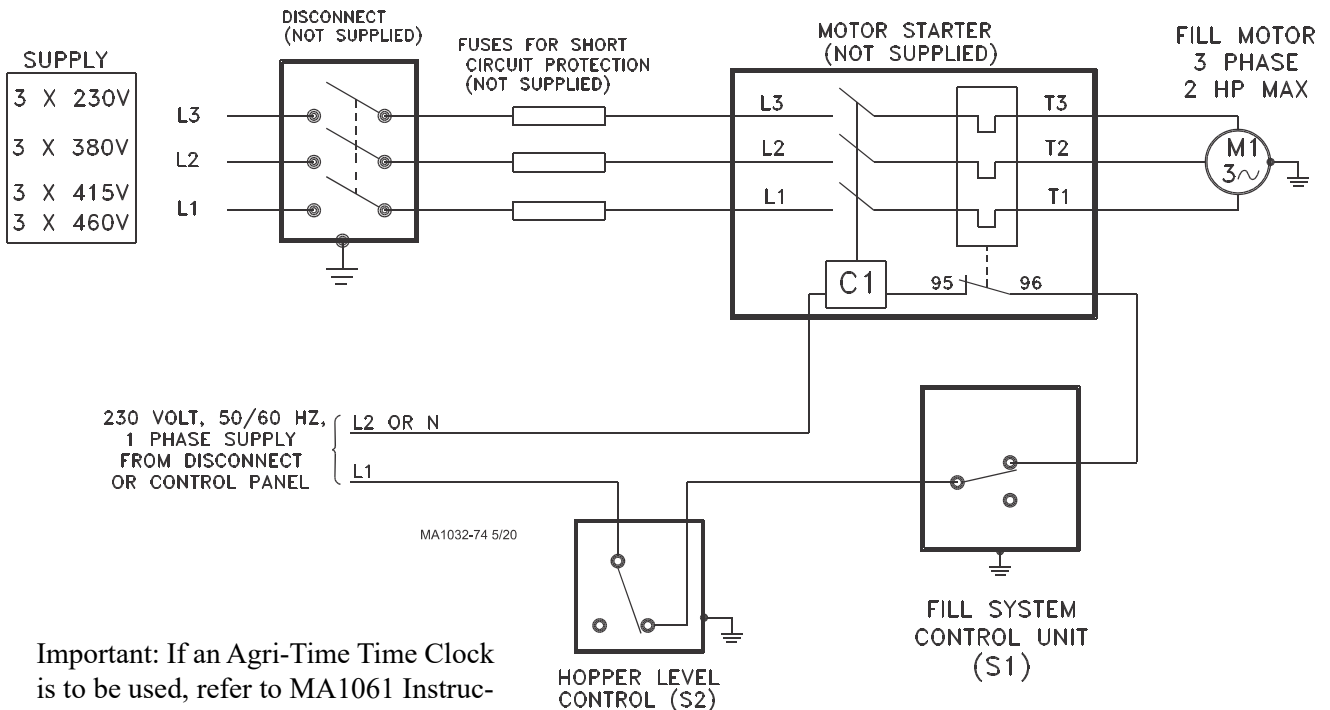

Important: If an Agri-Time Time Clock is to be used, refer to MA1061 Instruction for control wiring.  
 If an Auger Timer is to be used, refer to MA951 Instruction for control wiring.

**Important:** If system is to be controlled by a Proximity Drop Tube Switch, refer to MA1044 Instruction for switch wiring.  
 If the system is to be controlled by a mechanical Drop Tube Switch, refer to MA1099 Instruction for switch wiring

## Operating Recommendations

1. During initial start-up, the boot slide should be only partially open to prevent the full length of auger from being charged with feed. After that, the boot slide must be fully open for delivery system operation.
2. Do not permit the FLEX-AUGER system to operate empty. Use a time clock or Auger Timer with the system whenever possible. This reduces short cycling by operating on a preset schedule instead of on demand. It also prevents excessive running of the system if the bin becomes empty. If the optional boot switch is used, the fill system will shut down when the bin becomes empty.
3. Program the time clock to fill feeders often so the FLEX-AUGER System does not have to run a long period of time to get feeders filled. Poultry feeders supplied by the FLEX-AUGER System should be operated by a time clock so feeders start at the same time. This gives the FLEX-AUGER System a better chance to keep up with them.

**Note:** The hopper level control must be positioned low in the last feeder hopper.

4. The red light on the control unit will light if feed has packed inside. If this happens, remove feed from the drop tube and tap the side of the power unit to clear the safety switch. Keep the hopper level control in adjustment and positioned straight up and down so the paddle swings freely. The safety switch does not take the place of the hopper level control.
5. If the FLEX-AUGER System must be used to convey high-moisture feed, empty the auger line completely after each running to prevent the feed from setting up in the tubes.
6. The Restrictor in the boot regulates the amount of feed flowing into the auger. Start a new system with the Restrictor installed as shipped--full length and flush with the front of the boot. Allow the system to polish out before adjusting the feed flow. Maximum restriction for the boots results when the restrictor is in this position. If more feed flow is desirable, the restrictor may be shortened. Refer to the section "Restrictor Adjustment" on **Page 29**.
7. When operating the Straight-Through Tandem System, open the slide on only one bin at a time!
8. Model 108 High-Moisture Corn Applications only:  
Chore-Time recommends purging the system after the last feeding each day. Do not allow feed to set in the tubes for more than 24 hours.

Additionally, do not allow the charged system to set idle in freezing conditions for extended periods of time.

## Start-Up Procedure for New Systems

DO NOT RUN FEED THROUGH A NEW SYSTEM UNTIL AFTER THIS PROCEDURE HAS BEEN FOLLOWED OR THE AUGER WILL PLUG AND BIND.

1. Close the slide on the FLEX-AUGER boot.
2. Operate the system empty for one minute.
3. Open the slide on the FLEX-AUGER boot no more than 1 inch (25 mm) to allow some feed into the boot.
4. Operate the system with the slide in this position until feed has been conveyed into the building at least 5 minutes. This removes the manufacturing grease and oil from the auger and tubes. If this grease and oil is not removed, the feed may ball up causing the auger to plug and bind.
5. Now the slide can be fully opened and the system operated normally.

# Parts Listing

## Miscellaneous Line Components

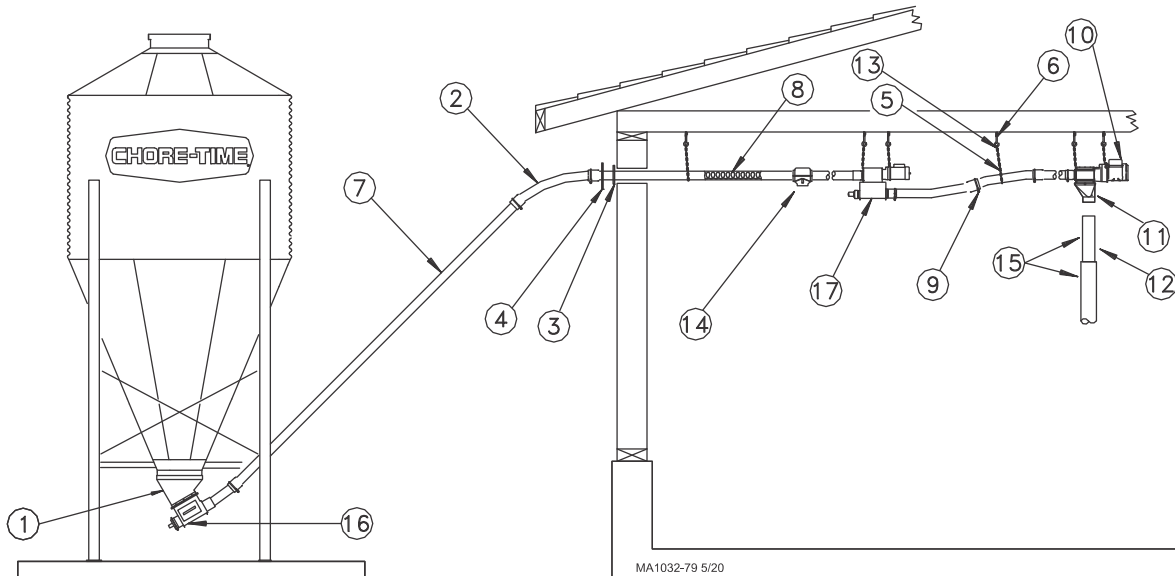

KEY	DESCRIPTION	PART NO.	KEY	DESCRIPTION	PART NO.
1	Upper Boot (30 Degree)	4347R/C	11	Control Unit (Direct Drive)	46800-5
	Upper Boot (Straight-Out)	6093R/C		Control Unit (Belt Drive)	46800-15
2	PVC Elbow, 45 Degree	34546		Control Unit (Direct Drive, 3 Phs)	46800-10
	--Optional 15 Degree Hard. Steel Elbow	34354	12	Plastic Drop Tube	9900
	--Optional 45 Degree Hard. Steel Elbow	34406	13	S Hook	2805
	--Optional 30 Degree Hard. Steel Elbow	34355	14	Outlet Drop	34358
3	Neoprene Seal	34334	15	Telescoping Drop Tube	14366-9900
4	Seal Ring	8117	16	Lower Boot Assembly (30 Degree)	34336
5	Chain	2128-100		Lower Boot Assembly (Straight-Out)	34341
6	Screw Hook	1214	17	Extension Boot Kit	47862-0
7	10' (3 m) PVC Tube	34547	--	Connector w/clamps (for steel systems)	34419
	10' (3 m) Steel Tube	34411	--	Connector (for steel systems)	30277
8**	Model 108 Auger	30108-0	--	Tube Connector (for PVC systems)	34557
9	Tube Clamp (for PVC systems)	14373			
	Tube Clamp (for steel systems)	34338			
10	Power Unit	See Individual Part Lists			

\*\*Auger may be ordered in lengths from 20 ft. to 200 ft.  
Ex. 30108-155 would be 155' of auger.

## Model 108 Drop Kit (Part No. 34358)

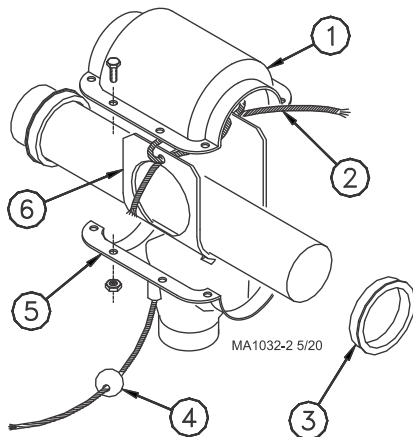

KEY	DESCRIPTION	PART NO.
1	Drop Half (top)	13780
2	.150 Dia. Rope	3085
3	Ring Adapter (for PVC systems)	34630
	Ring Adapter (for STEEL systems)	34360
4	Indicator Ball (red)	24393-1
	Indicator Ball (green)	24393-2
5	Drop Half (bottom)	13781
6	Rotary Slide	34359

# Power Units

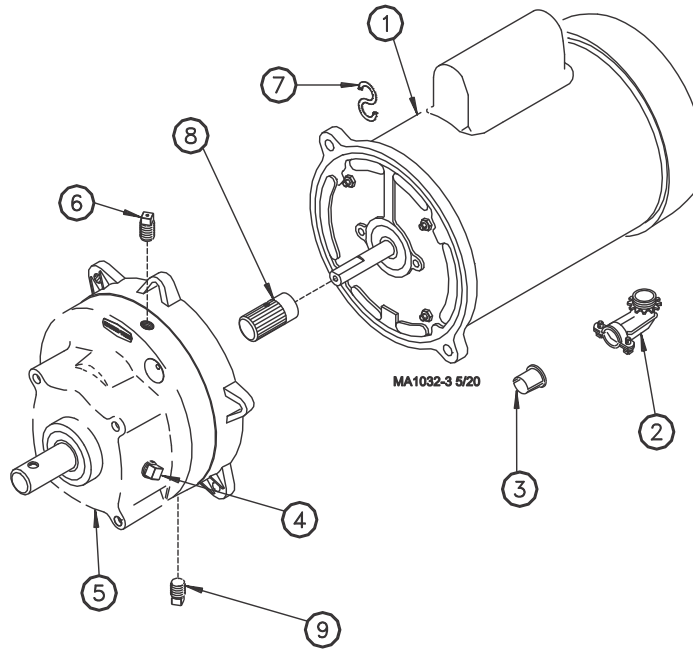

Item	Description	3259-49	3259-52	3259-66	3259-79	3259-80	3259-121
		Part No.	Part No.	Part No.	Part No.	Part No.	Part No.
1	Motor	6857	5051	8782	6857	8782	34461
2	90 Degree Connector	4228	4228	4228	4228	----	----
3	Anti-Short Bushing	6304	6304	6304	6304	----	----
4	Pipe Plug	2755	2755	2755	2755	2755	2755
5	Gearhead	3261-7	3261-7	3261-7	3261-10	3261-10	3261-10
6	Vent Plug	3523	3523	3523	3523	3523	3523
7	S Hook	2805	2805	2805	2805	2805	2805
8	Pinion Assembly	6104	5046	6104	6104	6104	6104
9	Magnetic Pipe Plug	30160	30160	30160	30160	30160	30160

Item	Description	3259-88	3259-89	3259-105	3259-106
		Part No.	Part No.	Part No.	Part No.
1	Motor	6305	26157	28035EUR	28036EUR
2	90 Degree Connector	4228	4228	----	----
3	Anti-Short Bushing	6304	6304	6304	6304
4	Pipe Plug	2755	2755	2755	2755
5	Gearhead	3261-10	3261-10	3261-10	3261-10
6	Vent Plug	3523	3523	3523	3523
7	S Hook	2805	2805	2805	2805
8	Pinion Assembly	5046	6104	6104	6104
9	Magnetic Pipe Plug	30160	30160	30160	30160

## Power Unit Assembly Part Numbers:

Part Number	HP	RPM	Phase	Hz	Voltage
3259-49	1 HP	348 RPM	Single Phase	60 Hz	230
3259-52	3/4 HP	348 RPM	Single Phase	60 Hz	230
3259-66	1-1/2 HP	348 RPM	Single Phase	60 Hz	230
3259-79	1 HP	425 RPM	Single Phase	60 Hz	230
3259-80	1-1/2 HP	425 RPM	Single Phase	60 Hz	230
3259-121	2 HP	425 RPM	Single Phase	60 Hz	230
3259-88	3/4 HP	348 RPM	Single Phase	50 Hz	230
3259-89	1 HP	348 RPM	Single Phase	50 Hz	230
3259-105	1 HP	348 RPM	Three Phase	50 Hz	220/380
3259-106	1-1/2 HP	348 RPM	Three Phase	50 Hz	220/380

### Single Phase Direct Drive Control Unit (Part No. 6500-22)

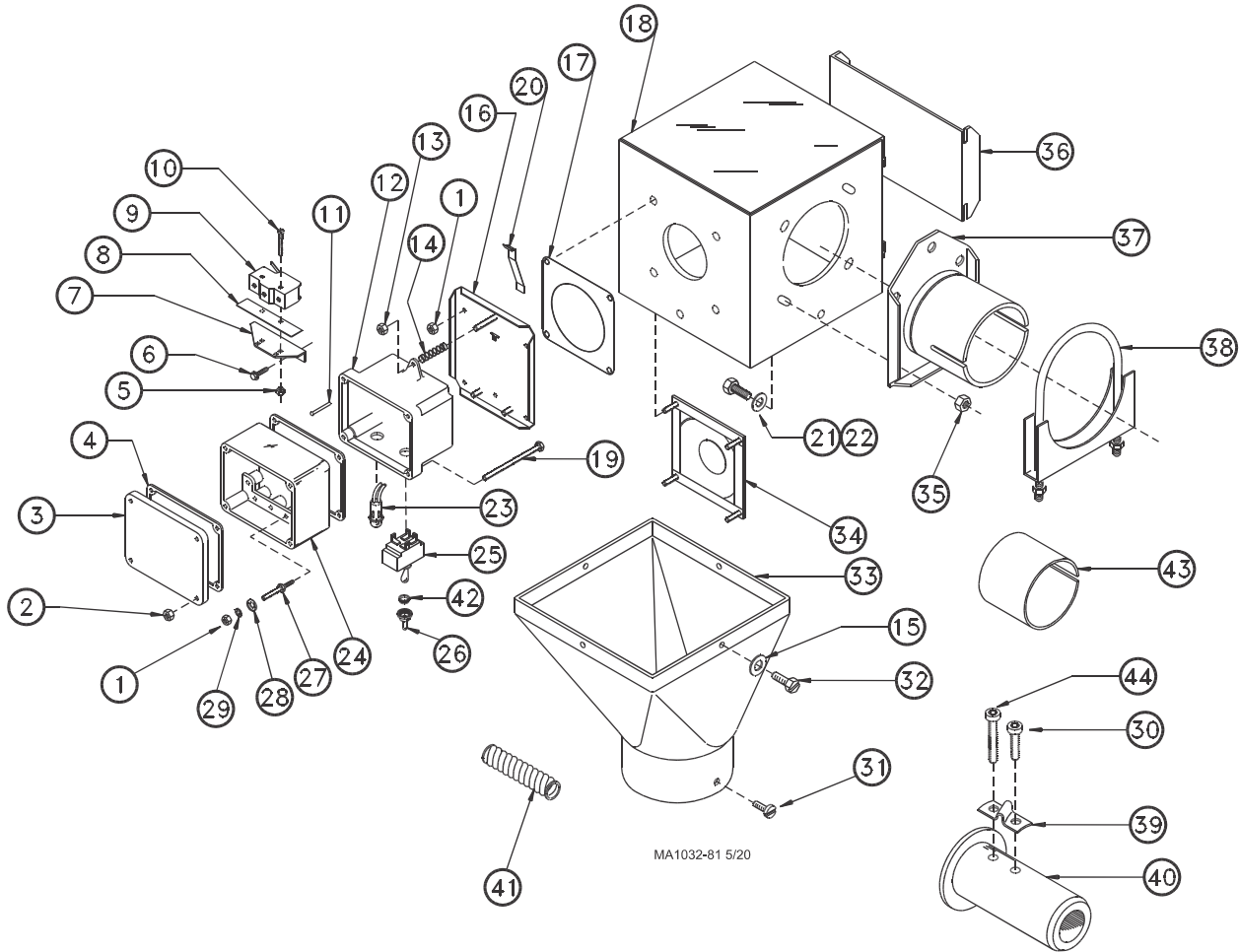

KEY	DESCRIPTION	PART NO.
1*	10-32 Hex Nut	4297
2*	8-32 Hex Nut	6519
3*	Switch Box Cover	6776
4*	Gasket	6777
5*	6-32 Hex Nut	771
6*	6x3/8 Washer Hd Screw	6782
7*	Switch Bracket	7068
8*	Switch Insulation	1907-5
9*	Snap Switch	46091
10*	6-32 x 7/8 Rd Hd Mach. Screw	1921
11*	Pin	8757
12*	Switch Box	7909
13*	10-32 Hex Lock Nut	6963
14*	Spring	6972
15	Washer	6723
16*	Mounting Plate Assembly	7908
17	Seal	4873
18	Body Weldment	8276
19*	8-32 x 2-5/8 Hx Hd Mach. Screw	7230-1
20*	Paddle	7896
21	5/16-18 x 1/2 Hx Hd Mach. Screw	1839
22	Flat Washer	546
23*	Pilot Light	7044
24*	Terminal Box	7774
25*	Toggle Switch	7767
26*	Toggle Switch Boot	13406
27*	10-32 Stud	7007
28*	Cup Washer	5775

KEY	DESCRIPTION	PART NO.
29*	#10 Star Washer	305
30**	5/16-18 x 7/8 Socket Hd Cap Screw	6850-1
31	8 x 1/2 Sheet Metal Screw	6725
32	10-24 x 5/8 Slot Hx Hd Mach Screw	1876
33	Drop	13803
34	Diaphragm Assembly	7900
35	5/16-18 Hex Lock Nut	2148
36	Slide	5073
37	Tube Anchor	34543
38	Tube Clamp Kit	14373
39**	Anchor Clamp	7703
40**	Driver Weldment	30312
41	3/8" Flex Cable	26982-10
42*	Shoulder Nut	13407
43	Tube Insert	34337
44**	5/16-18 x 2-3/4 Socket Hd Cap Screw	6850-2
--	Liquid Tight Connector	23810

\*May be ordered as an assembly under Chore-Time Part No. 876 Switch Assembly.

\*\*May be ordered as an assembly under Chore-Time Part No. 303 Driver Assembly.

## Single Phase Belt Drive Control Unit (Part No. 6500-21)

**Note:** The 6500-21 Belt Drive Control Unit includes the Direct Drive Control Unit components, plus the following components.

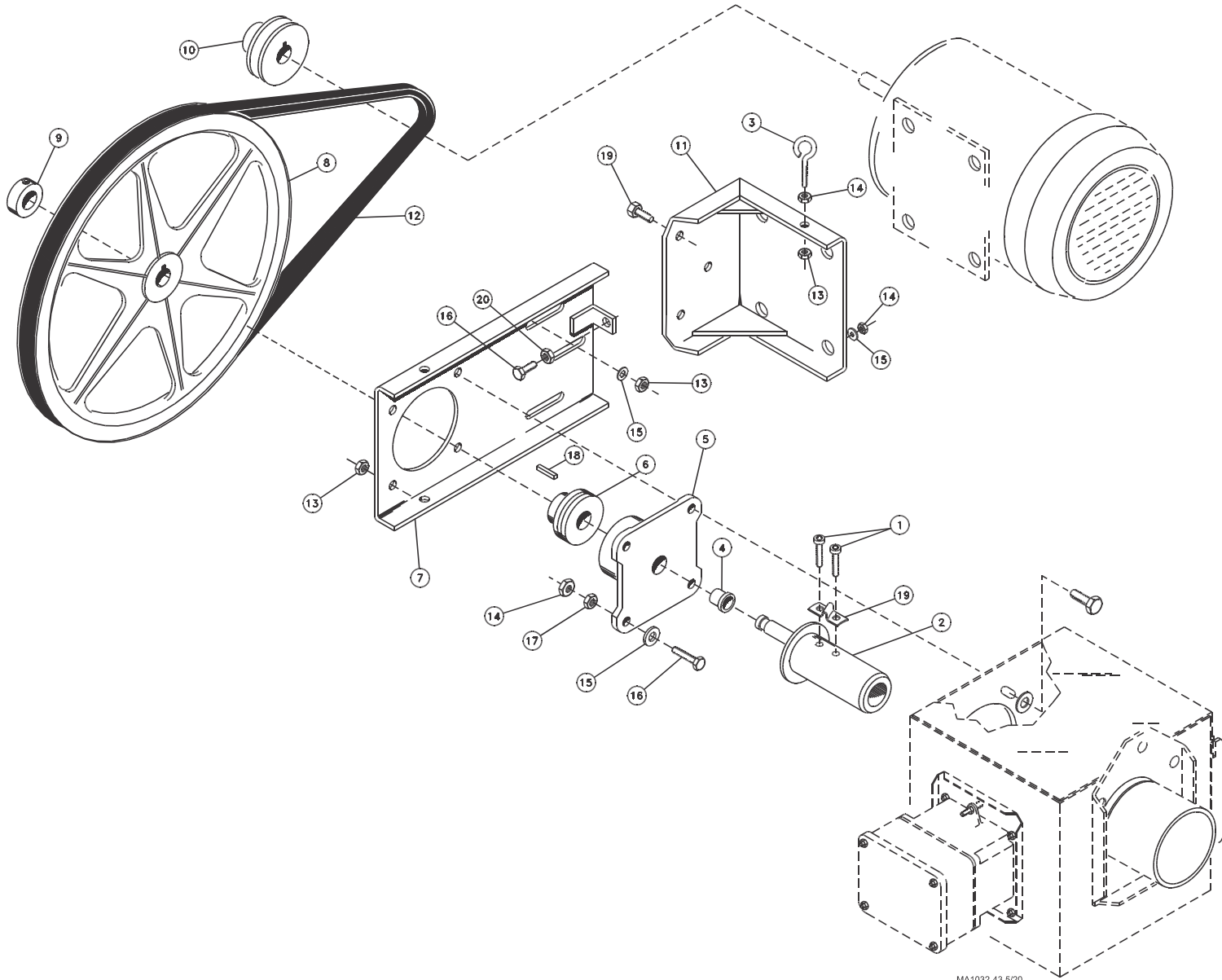

MA1032-43 5/20

<u>Key</u>	<u>Description</u>	<u>Part No.</u>
1	5/16-18 x 7/8 Socket Hd Screw	6850-1
2	Driver Weldment	34346
3	Eyebolt	1503-2
4	Flange Bearing	2196
5	Front Plate Housing	2047
6	Ball Bearing	5930
7	Adjustment Bracket	46301
8	14" (356 mm) Dia. Sheave	1500
9	5/8" Set Collar	1386
10	2.7" (69 mm) Dia. Sheave	1381
11	Motor Mount Weldment	3058

<u>Key</u>	<u>Description</u>	<u>Part No.</u>
12	"V" Gripnotch Belt	3096
13	5/16-18 Hex Locknut	2148
14	5/16-18 Jam Nut	593
15	5/16 Flat Washer	546
16	5/16-18x1-3/4" Hex Hd. M.S.	4412-4
17	5/16-18 Hex Lock Nut	2148
18	3/16" Key	2112-1
19	Anchor Clamp	7703
20	5/16-18 Hex Nut	2145

The Belt Drive Parts Package (includes all of the above) may be ordered under Chore-Time part no. 47870-XX.



### Three Phase Direct Drive Control Unit (Part No. 25770-6)

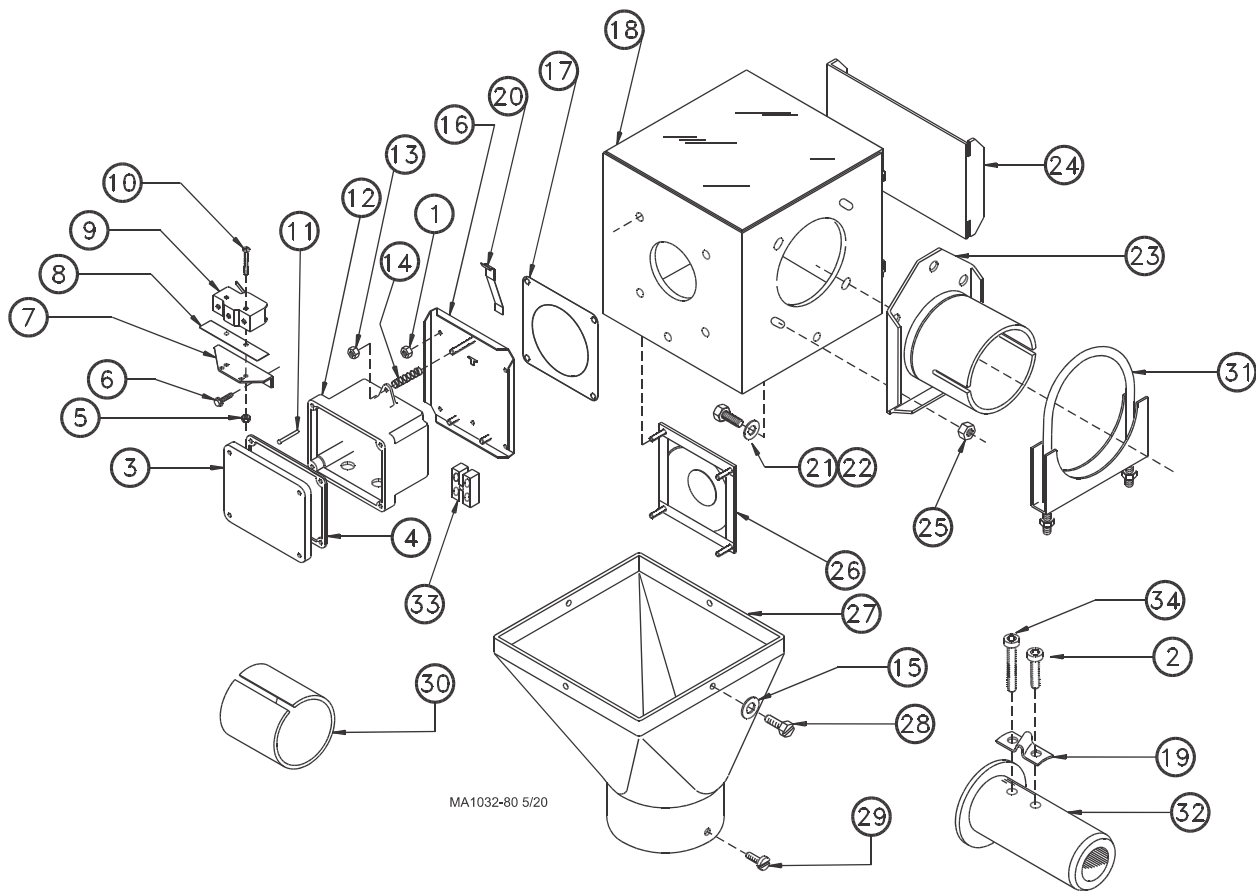

MA1032-80 5/20

KEY	DESCRIPTION	PART NO.	KEY	DESCRIPTION	PART NO.
1	#10-32 Hex Nut	4297	20	Paddle	7896
2**	5/16-18 x 7/8" Socket Hd Cap Screw	6850-1	21	5/16-18 x 1/2" Fastener	1839
3	Switch Box Cover	6776	22	5/16" Flat Washer	546
4	Gasket	6777	23	Tube Anchor Weldment	34543
5	#6-32 Hex Nut	771	24	Slide	5073
6	#6 x 3/8" Hex Hd SMS	6782	25	5/16-18 Locknut	2148
7	Switch Bracket	7068	26	Diaphragm Assembly	7900
8	Switch Insulation	1907-5	27	Drop	13803
9	Snap Switch	46091	28	#10-24 x 5/8" Hx Wash Hd Screw	1876
10	#6-32 x 7/8" Pan Hd. Screw	1921	29	#8 x 1/2" SMS	6725
11	1/8 x 1" Rd Hd Rivet	8757	30	Tube Insert	34337
12	Switch Box (Machined)	7841	31	Clamp Kit	14373
13	#10-32 Lock Nut	6963	32**	Driver Weldment	30312
14	Spring	6972	33	Terminal Strip	34925-2
15	#10 Flat Washer	6723	34**	5/16-18 x 2-3/4 Socket Hd Cap Screw	6850-2
16	Mounting Plate Assembly	7908			
17	Seal	4873			
18	Body Assembly	8276			
19**	Anchor Clamp	7703			

\*\*These components may be ordered under Chore-Time Part No. 30313 Driver Assembly.

# Model 108 Boot Components

The Item numbers below are associated with the parts lists on the following two pages.

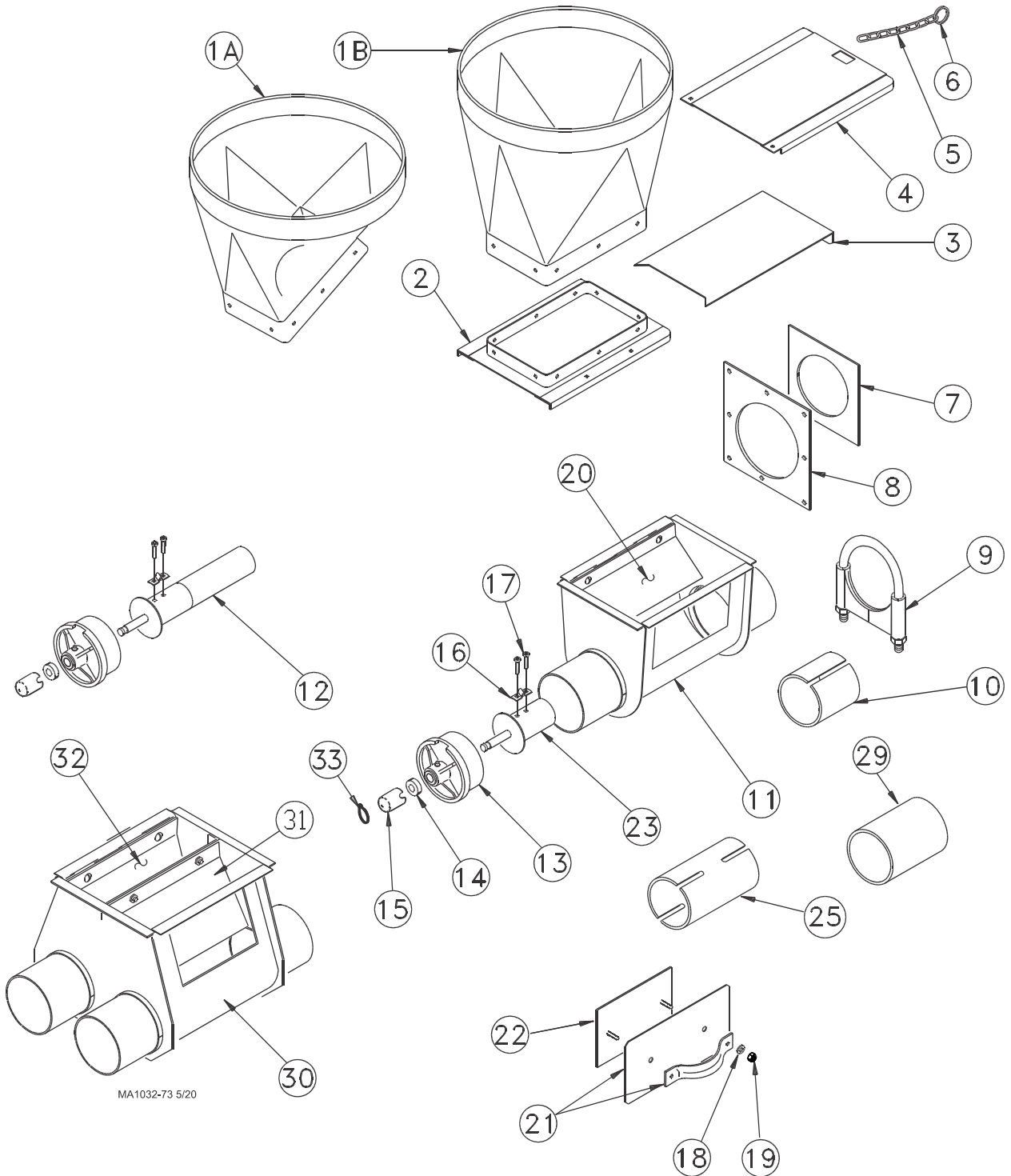

MA1032-73 5/20

## Model 108 Boot Components

The Item numbers below are associated with the diagram on the previous page.

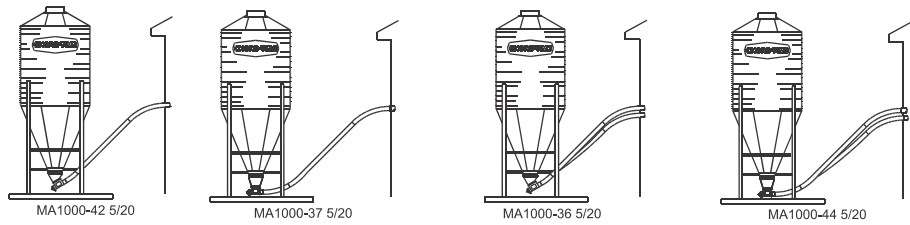

Item	Description	30 Degree Boot System	Straight-Out Single Boot System	30 Degree Twin Boot System	Straight-Out Twin Boot System
--	Complete System	34339	34340	35625	35626
-- <sup>2</sup>	Lower Boot Assembly	34336	34341	35613	35612
1A	30 Degree Upper Boot	4347R/C	----	4347R/C	----
1B	Straight Out Upper Boot	----	6093R/C	----	6093R/C
2	Transfer Plate Assembly	4925	4925	4925	4925
3	Slide	4357	4357	4357	4357
4	Slide Shield	4876	4876	4876	4876
5	Chain	2128-250	2128-250	2128-250	2128-250
6	Ring	1706	1706	1706	1706
7	Neoprene Seal	34334	34334	34334	34334
8	Seal Ring	8117	8117	8117	8117
9	Tube Clamp (for STEEL systems)	34338	34338	34338	34338
9 <sup>3</sup>	Tube Clamp (for PVC systems)	14373	14373	14373	14373
10	Tube Insert	34337	34337	34337	34337
11	Boot Body Weldment	30386	30385	----	----
12 <sup>5</sup>	Anchor Weldment	30311	----	30311	----
13 <sup>5</sup>	Bearing Cap Assembly	30314	30314	30314	30314
14 <sup>5</sup>	5/8" Set Collar	1386	1386	1386	1386
15 <sup>5</sup>	Safety Cap	29702	29702	29702	29702
16 <sup>5</sup>	Anchor Clamp	7703	7703	7703	7703
17 <sup>5</sup>	5/16-18 x 7/8 Socket Hd Cap Screw	6850-1	6850-1	6850-1	6850-1
18 <sup>1</sup>	Sealing Washer	39-20155	39-20155	39-20155	39-20155
19 <sup>1</sup>	5/16-18 Lock Nut	2148	2148	2148	2148
20	Baffle	----	14239	----	----
21 <sup>1</sup>	Cover Weldment	6301	6301	6301	6301
22 <sup>1</sup>	Back Plate Assembly	6298	6298	6298	6298
23 <sup>5</sup>	Anchor Weldment	----	34369	----	34369
25 <sup>4,3</sup>	Model 108 Connector	30277	30277	30277	30277
29 <sup>3</sup>	Tube Connector (for PVC systems)	34557	34557	34557	34557
30	Twin Boot Body Weldment	----	----	35617	35617
31	Center Baffle Plate	---	----	----	35624
32	Baffle Weldment	----	----	----	35615
33	Cable Tie	56705	56705	56705	56705

<sup>1</sup>These components may be ordered under Chore-Time Part No. 6197 Clean-Out Cover Assembly.

<sup>2</sup>Items 2 through 32 make up the Lower Boot Assemblies.

<sup>3</sup>These items are not included in the package and must be ordered separately.

<sup>4</sup>The Model 108 Connector may be ordered with (2) 34338 Tube Clamps under Chore-Time Part No. 34419 Connector w/Clamps.

<sup>5</sup>Items 12 - 17 may be ordered as an Anchor & Bearing Assembly (Restricted) under Chore-Time Part No. 35767. Items 13 - 17 and item 23 may be ordered as an Anchor & Bearing Assembly (Unrestricted) under Chore-Time Part No. 35766.

## Model 108 Boot Components (continued)

The Item numbers below are associated with the parts list drawing two pages prior.

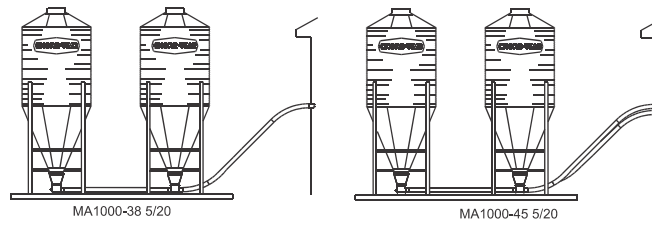

Item	Description	Straight-Thru Single Boot System	Straight-Thru Twin Boot System
--	Complete System	34333	35616
-- <sup>1</sup>	Straight-Out Lower Boot Assembly	34341	35612
-- <sup>2</sup>	Straight-Thru Lower Boot Assembly	34335	35611
1B	Straight Out Upper Boot	6093R/C	6093R/C
2	Transfer Plate Assembly	4925	4925
3	Slide	4357	4357
4	Slide Shield	4876	4876
5	Chain	2128-250	2128-250
6	Ring	1706	1706
10	Tube Insert	34337	34337
11	Boot Body Weldment	30385	----
18 <sup>3</sup>	Sealing Washer	39-20155	39-20155
19 <sup>3</sup>	5/16-18 Lock Nut	2148	2148
20	Baffle	14239	----
21 <sup>3</sup>	Cover Weldment	6301	6301
22 <sup>3</sup>	Back Plate Assembly	6298	6294
30	Twin Boot Weldment	----	35617
31	Center Baffle Plate	---	35624
32	Baffle Weldment	----	35615

<sup>1</sup>Refer to the Straight-Out Boot Systems on for miscellaneous Straight-Out Lower Boot Assembly components. See "Model 108 Boot Components" on page 42.

<sup>2</sup>Items 2 through 32, as listed above, make up the Straight-Thru Lower Boot Assemblies.

<sup>3</sup>These items may be ordered as an assembly under Chore-Time Part No. 6197.

# Troubleshooting

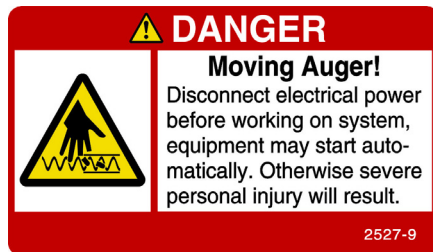
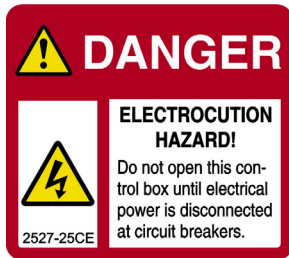

**ALWAYS DISCONNECT POWER TO THE SYSTEM WHEN SERVICING OR MAINTAINING THE EQUIPMENT. FAILURE TO DISCONNECT POWER MAY CAUSE INJURY OR DEATH.**

Service and maintenance work should be done by a qualified technician only.

Problem	Possible Cause	Corrective Action
Delivery system will not run.	No power to the system.	Check circuits, fuses, and on-off switches on the equipment.
	Bin level switch has stopped the system due to lack of feed in the boot.	Check feed supply and for possible bridging.
	Motor overloaded and stopped.	Check for foreign material in the line. Push the motor reset button.
	Safety switch actuated in the Control Unit (red pilot light will be lit).	Determine reason for feed packing in the Control Unit. Feed level switch out of adjustment?
Motor overloads after running briefly.	Motor too small.	Use recommended size motor for line length.
	Low voltage (motor runs slow and overheats).	Check line voltage at the motor; use adequate size wire in circuits.
	Foreign object in the auger (motor runs, stalls, then auger spins in reverse).	Check auger line, pull auger to remove objects.
	Motor wired in reverse (motor runs, stalls, no feed conveyed).	Disconnect power and change wire connections (direct drive power unit shaft at rear of motor turns clockwise).
	Boot Anchor tight.	Check for Anchor binding.
	Wet feed being conveyed or allowed to stand in auger tubes. Defective motor (over heats without load).	Clean auger and tubes; avoid conveying wet feed or empty line after each feeding. Replace motor.

<b>Problem</b>	<b>Possible Cause</b>	<b>Corrective Action</b>
Motor runs, but auger does not turn.	Sheared driver bolt at Control Unit.	Replace driver bolt.
	Broken power unit pinion.	Examine pinion on motor shaft; replace BOTH gear head and pinion in pinion is damaged.
Auger wears holes in tubes.	Auger kinked or poorly brazed.	See Auger Brazing section in this manual
Elbows wear out.	Auger is stretched too tight; horizontal L.H. turn; auger has been run dry.	Lengthen auger; Install an Extension Hopper; wire Boot Switch into system.
Excessive auger vibration and noise.	System has been operated too often without feed (auger has scored the auger tubes).	Wire a Boot Switch to stop the system when the feed bin is empty; replace damaged auger tubes; be sure auger has proper amount of stretch.
	Tubes inadequately supported.	Support the tubes every 5' (1.5 m) or closer.
	Horizontal L.H. turn.	No outlet drops on or just before an elbow; lengthen the auger; install an Extension Hopper ahead of elbows.
Fill system short cycles.	Control end feed level switch does not provide large enough feed differential.	Use a time clock to program operating cycles. Use Control end feed level switch w/lockout and time clock.
Extension Boot packs full of feed.	Too much Restrictor in the Boot.	Shorten Restrictor.
Second portion of extended length system short cycles.	Too much Restrictor in the Boot.	Shorten Restrictor.
	Too much feed is still dispensing from drops ahead of Extension Boot.	Last outlet drop before Extension Boot must have full feed drop out. NOTE: All feeders ahead of Extension Boot must complete filling before feed reaches hopper.
Second portion of extended length system short cycles.	Too much Restrictor in the Boot.	Shorten Restrictor.

## Maintenance

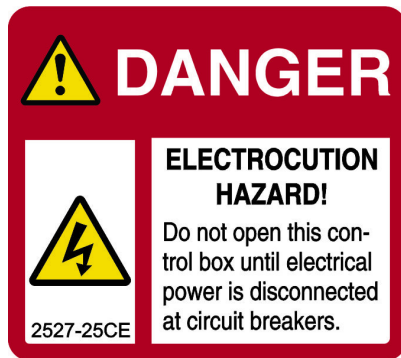

The FLEX-AUGER Feed Delivery System requires minimum maintenance. However, a routine periodic inspection of the equipment will prevent unnecessary problems.

Maintenance should be done by a qualified technician.

**ALWAYS DISCONNECT POWER TO THE SYSTEM WHEN SERVICING OR MAINTAINING THE EQUIPMENT. FAILURE TO DISCONNECT POWER MAY CAUSE INJURY OR DEATH.**

1. Periodically check and tighten the delivery system hardware.
2. Grease boot bearings on grease fittings regularly, using an automotive or industrial type grease.
3. Keep the FLEX-AUGER tubes level. Adjust if necessary. Wear increases at the points where tubes sag.
4. Replace the Plastic Shipping Plug in the power unit gear head with the Vented Plug during installation of the Power Unit.
5. Check the oil level in the gear heads at installation and every 6 months. The Pipe Plug, on the side of the gear head, indicates proper oil level. Add SAE 40W oil when necessary.

The oil in the gear heads should be replaced every 12 months with new SAE 40W oil.

- A. Remove the bottom Pipe Plug to drain the oil. Discard used oil in accordance with local and national codes.
- B. Wipe any debris off the magnet on the bottom Pipe Plug and reinstall. Remove the side Pipe Plug and (top) Vent Plug.
- C. Set the power unit in the horizontal position.
- D. 2-Stage Gear Heads: Add approximately 9 oz. (266 ml) of SAE 40W oil through top hole. This should be just enough oil to reach the side Pipe Plug.
- 3-Stage Gear Heads (3261-9, 3261-12, 3261-14): Add approximately 13 oz. (384 ml) of SAE 40W oil through top hole. This should be just enough oil to reach the side Pipe Plug.
- E. Install the side Pipe Plug and (top) Vent Plug.
6. If the system is not to be used for an extended period of time, remove all the feed from the auger lines.

Disconnect power to the system to prevent accidentally starting the system.

7. If the system must be disassembled, extreme caution must be used to prevent injury from springing auger.
  - A. Disconnect power to the entire system.
  - B. Pull the Anchor and Bearing Assembly and approximately 18" (45 cm) of auger out of the boot.
  - C. Place a clamp or locking pliers on the auger to prevent it from springing back into the auger tubes.
  - D. Anchor and Bearing Assembly.
  - E. Carefully release the clamp securing the auger.

**CAUTION:** Stand clear...the auger will spring back into the tubes.

- F. Remove the remaining system components in the opposite order they were installed, according to this manual.



## 8. Replacing the battery in the Agri-Timer:

- A. Disconnect electrical service at the breaker.
- B. Remove the (2) screws and the face of the timer.
- C. Replace the existing batteries with new batteries.
- D. Use existing wire ties to secure the new batteries in place.
- E. Reinstall the face of the timer and secure using (2) screws previously removed.
- F. Reconnect electrical service to the system.

**Proximity Switch Adjustment Procedures:**

The Proximity Switch includes an adjustable delay. The delay may be set from 1 second to 10 minutes.

1. Use a small screw driver provided to turn the Delay Adjustment Screw (**See Figure 24.**) Turn the screw counter clockwise until the light stays on. Turn the screw clockwise one complete revolution. This sets the delay to 1 second.
2. To increase the delay, turn the Delay Adjustment Screw clockwise.  
Watch the indicator light; quick flashes = shorter time delay, slow flashes = longer time delay.

The Proximity Switch is shipped with the sensitivity preset at the factory. This setting is adequate for most feed types and conditions. However if the sensitivity does need to be adjusted, carefully follow these instructions:

3. Allow power to be supplied to the switch for at least 15 minutes to properly warm the sensor. Chore-Time recommends wiring the proximity switch to have a constant 220 V. supply. See the wiring diagrams supplied with the Proximity Switch.
4. Set the Proximity Switch time delay to 1 second as specified in the instructions above.
5. Use a small screw driver to remove the caulk concealing the Sensitivity Adjustment Screw (**See Figure 24.**)
6. **IMPORTANT:** A Proximity Switch may be used in a feed bin boot to shut the fill system down when it no longer senses feed.

A Proximity Switch may also be used as a feed level switch at the control end of the line. In this application the switch is used to shut the system down when it senses feed.

Before adjusting the Proximity Switch, carefully consider how you want the switch to react when it senses feed. For addition information, see the instructions shipped with the Proximity Switch.

Greater switch sensitivity is achieved by turning the Sensitivity Adjustment Screw clockwise.

Less switch sensitivity is achieved by turning the Sensitivity Adjustment Screw counterclockwise.

Note the screw orientation before beginning adjustment. Adjust the Sensitivity Adjustment Screw 1/4 turn, test switch, continue adjusting as required.

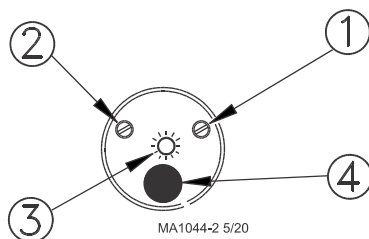

Key	Description
1	Sensitivity Adjustment Screw
2	Delay Adjustment Screw
3	Indicator Light
4	Power Cord

**Figure 24. Proximity Switch End View**

Discard damaged or replaced equipment according to local and national codes. Many of the components may be recycled.



## Cementing the PVC Auger Tube

The auger tubes and elbows for the FLEX-AUGER systems are made of specially formulated PVC tubing. Use the PVC solvent cement to make strong, reliable bonds.

FOLLOW DIRECTIONS ON THE CAN FOR SAFE HANDLING OF CEMENT.

1. Be sure tube is cut off squarely. Remove burrs from outside and inside the end of the tube.
2. Dry fit all parts. Tube should fit inside belled end of next tube to full depth without excess force.
3. Clean surfaces to be joined. SURFACES MUST BE FREE OF DIRT OR GREASE!
4. Apply a generous coat of cement to both the inside of the belled end and outside of the other tube. Be sure cement covers all of the joint area so there are no bare spots.
5. Quickly join the tubes, giving them a twisting motion to bring them into alignment as they are joined.
6. Keep pressure on the joint until the PVC cement sets up.

## Livestock and Poultry Feed Consumption

### Poultry

Poultry applications use automatic feeding systems sized for the building density. The FLEX-AUGER Feed Delivery System’s delivery rate should be sized to match or exceed the sum of the delivery rates of the automatic feeders supplied.

#### CHORE-TIME Floor Feeding Systems

#### Delivery Rates

Model C, C2, H2, and G with 216 RPM Power Unit . . . . .	10.8 lbs or 4.89 kg/min.*
Model C, C2, H2, and G with 348 RPM Power Unit . . . . .	17.0 lbs or 7.71 kg/min.*
Model ATF . . . . .	18.0 lbs or 8.16 kg/min.*
Pan Breeder Feeder System . . . . .	35.0 lbs or 15.87 kg/min.*
ULTRAFLO Breeder Feeder (per Hopper) . . . . .	52.0 lbs or 23.58 kg/min.*
ULTRAPAN Feeding System (per Hopper) . . . . .	50.0 lbs or 22.68 kg/min.*

\*Based on 40 lbs/ft<sup>3</sup> density (64 kg/m<sup>3</sup>)

### Hogs

#### Live weight-lbs/Hog

#### Total Average Daily Feed-lbs/Head

10-25 (4.5-11.3 kg) . . . . .	1.2 (.54 kg)
25-50 (11.3-22.7 kg) . . . . .	2.5 (1.13 kg)
50-75 (22.7-34 kg) . . . . .	4.0 (1.81 kg)
75-125 (34-56.7 kg) . . . . .	5.2 (2.35 kg)
125-175 (56.7-79.4 kg) . . . . .	6.7 (3.04 kg)
175-225 (79.4-102 kg) . . . . .	7.8 (3.54 kg)

Gestating Sows 5 (2.26 kg)

### Dairy

#### Milk/Cow/Day-lbs Average

#### Concentrates\*/Cow/Day-lbs Average

30 (13.61 kg) . . . . .	10 (4.53 kg)
50 (22.68 kg) . . . . .	20 (9.07 kg)
70 (31.75 kg) . . . . .	30 (13.61 kg)
80 (36.28 kg) . . . . .	40 (18.14 kg)

TO DETERMINE THE RUNNING TIME PER DAY-Multiply the number of animals by the feed consumption/ head figures from the charts to get Total Feed Consumption.

-Divide Total Feed Consumption by the stated delivery rate of the FLEX-AUGER Feed Delivery System to get running time per day in minutes. Divide this by 60 to get running time per day in hours.

## Cementing the PVC Auger Tube

The auger tubes and elbows for the FLEX-AUGER systems are made of specially formulated PVC tubing. Use the PVC solvent cement to make strong, reliable bonds.

FOLLOW DIRECTIONS ON THE CAN FOR SAFE HANDLING OF CEMENT.

1. Be sure tube is cut off squarely. Remove burrs from outside and inside the end of the tube.
2. Dry fit all parts. Tube should fit inside belled end of next tube to full depth without excess force.
3. Clean surfaces to be joined. SURFACES MUST BE FREE OF DIRT OR GREASE!
4. Apply a generous coat of cement to both the inside of the belled end and outside of the other tube. Be sure cement covers all of the joint area so there are no bare spots.
5. Quickly join the tubes, giving them a twisting motion to bring them into alignment as they are joined.
6. Keep pressure on the joint until the PVC cement sets up.

# Livestock and Poultry Feed Consumption

## Poultry

Poultry applications use automatic feeding systems sized for the building density. The FLEX-AUGER Feed Delivery System’s delivery rate should be sized to match or exceed the sum of the delivery rates of the automatic feeders supplied.

<b>CHORE-TIME Floor Feeding Systems</b>	<b>Delivery Rates</b>
Model C, C2, H2, and G with 216 RPM Power Unit . . . . .	10.8 lbs or 4.89 kg/min.*
Model C, C2, H2, and G with 348 RPM Power Unit . . . . .	17.0 lbs or 7.71 kg/min.*
Model ATF . . . . .	18.0 lbs or 8.16 kg/min.*
Pan Breeder Feeder System . . . . .	35.0 lbs or 15.87 kg/min.*
ULTRAFLO Breeder Feeder (per Hopper) . . . . .	52.0 lbs or 23.58 kg/min.*
ULTRAPAN Feeding System (per Hopper) . . . . .	50.0 lbs or 22.68 kg/min.*

\*Based on 40 lbs/ft<sup>3</sup> density (64 kg/m<sup>3</sup>)

## Hogs

<b>Live weight-lbs/Hog</b>	<b>Total Average Daily Feed-lbs/Head</b>
10-25 (4.5-11.3 kg) . . . . .	1.2 (.54 kg)
25-50 (11.3-22.7 kg) . . . . .	2.5 (1.13 kg)
50-75 (22.7-34 kg) . . . . .	4.0 (1.81 kg)
75-125 (34-56.7 kg) . . . . .	5.2 (2.35 kg)
125-175 (56.7-79.4 kg) . . . . .	6.7 (3.04 kg)
175-225 (79.4-102 kg) . . . . .	7.8 (3.54 kg)
Gestating Sows <sup>5</sup> (2.26 kg)	

## Dairy

<b>Milk/Cow/Day-lbs Average</b>	<b>Concentrates*/Cow/Day-lbs Average</b>
30 (13.61 kg) . . . . .	10 (4.53 kg)
50 (22.68 kg) . . . . .	20 (9.07 kg)
70 (31.75 kg) . . . . .	30 (13.61 kg)
80 (36.28 kg) . . . . .	40 (18.14 kg)

TO DETERMINE THE RUNNING TIME PER DAY-Multiply the number of animals by the feed consumption/ head figures from the charts to get Total Feed Consumption.

-Divide Total Feed Consumption by the stated delivery rate of the FLEX-AUGER Feed Delivery System to get running time per day in minutes. Divide this by 60 to get running time per day in hours.

**This page left blank intentionally.....**

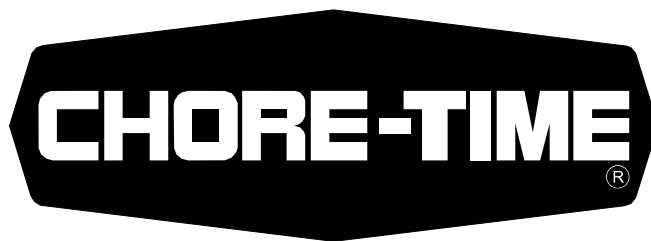

**MADE TO WORK.  
BUILT TO LAST.®**

### **Revisions to this Manual**

<b>Page No.</b>	<b>Description of Change</b>	<b>ECO</b>
Various	Updated to CE standards.	34835
12	Changed 34633-1 to 47862-1, 34633-3 to 47862-3, 8491 to 39-20155, 2146 to 2148, 29703 to 29702, Added: 56705	
37	Changed 4270 to 2805 Reformatted to Book form.	

**For additional parts and information, contact your nearest Chore-Time distributor or representative.  
Find your nearest distributor at: [www.choretime.com/contacts](http://www.choretime.com/contacts)**

CTB, Inc.  
PO Box 2000  
Milford, Indiana 46542-2000 USA  
Phone (574) 658-4101 Fax (877) 730-8825  
Email: [choretime@choretime.com](mailto:choretime@choretime.com)  
Internet: [www.choretime.com](http://www.choretime.com)