

# CHORE-TIME<sup>®</sup>

## *Poultry Production Systems*

### A600-2GLP, A600-2GN, A600-2O 110V and 220V INCINERATOR Installation and Operators Manual



Chore-Time Equipment  
P.O. Box 2000  
Milford, IN 46542  
Ph – 574-658-4101  
Fax – 577-730-8825  
[www.choretime.com](http://www.choretime.com)



#### **WARRANTY WARNING**

1. Tampering with orifices in the burner will void warranty.
2. Failure to cure refractory before using will void warranty.

## WARRANTY

Chore-Time Equipment, a division of CTB, Inc., WARRANTOR, warrants to the original purchaser for a period of one (1) year from date of purchase or delivery to original purchase, products manufactured by it which are installed and operated according to WARRANTS'S instructions that are furnished and/or are available to purchaser upon request, and installed according to other applicable Federal, State, and local codes or regulations and upon substantiation that said products were installed correctly, were not abused, and or defective. The exact nature of said warranty and exclusive remedy for breach of warrantor is as follows:

WARRANTOR will refund or credit to purchaser's account an amount equal to the original purchase price or at WARRANTOR'S option repair or replace at WARRANTOR'S expense products found to be defective in workmanship or material. If a problem occurs which the purchaser believes is covered by this warranty, then purchaser shall contact the seller giving the seller sufficient information to enable a resolution to the problem. If the seller is unable or unwilling to resolve the problem and purchaser is still convinced that it is covered by the warranty the purchaser should contact the manufacturer at the address listed in the following paragraph and provide a description in writing of the problem and the attempts made to resolved it. "Seller" as used herein shall mean the dealer or distributor from whom the product was purchased.

No product or part thereof may be returned pursuant to this warranty without first receiving specific written permission to do so. All request should be addressed to Chore-Time Equipment at P.O. 2000, Milford, IN 46542, requesting specific authority for returning merchandise pursuant to this warranty with reasons for the request.

## LIMITATIONS

Products which are abused or neglected are not covered under this Warranty. WARRANTOR shall not be responsible for the costs of removal or reinstallation of its products and shall not be liable for transportation costs to and from it factory. Further, WARRANTOR shall not be liable for replacement, repair, or refund for component parts not manufactured by it.

Use of parts for modification or repair of the unit or any component not authorized or manufactured by Chore-Time Equipment, specifically for this product shall void this warranty.

IMPLIED WARRANTIES OF MERCHANTABILITY AND FITNESS FOR A PARTICULAR PURPOSE ARE LIMITED TO THE SAME PERIOD OF TIME AS THIS EXPRESS LIMITED ONE (1) YEAR WARRANTY AND ARE SPECIFICALLY DISCLAIMED THEREAFTER.

CHORE-TIME EQUIPMENT, SHALL NOT BE LIABLE FOR ANY INCIDENTAL, CONSEQUENTIAL, SPECIAL, OR CONTINGENT DAMAGES OR EXPENSES ARISING DIRECTLY OR INDIRECTLY FROM ANY DEFECT IN THE PRODUCT HEREBY WARRANTED.

THIS WARRANTY SHALL BE VOID IF SOLVENTS OR OTHER HIGHLY INFLAMMABLE FLUIDS, SUCH AS BUT NOT LIMITED TO, BENZENE, METHYLETHYL, KETONES, TOLUENE, XYLENE, OR NAPHTHA ARE BURNED IN OR MIXED WITH OIL FOR BURNING IN USED OIL-FIRED BURNING HEATERS OR FURNACES.

For those states that do not allow limitations on how long an implied warranty lasts, this limitation may not apply. Similarly, for those states that do not allow the exclusion on limitations of incidental or consequential damages, the above exclusions of indirect, incidental, or consequential damages may not apply.

This warranty gives you specific legal rights and you may also have other rights which vary from state to state.

Chore-Time Equipment is not responsible for any undertaking, representation, or warranty made by dealer, distributor, or other persons, beyond those expressly set forth in this warranty.

# A600-2 BURNER INCINERATOR SPECIFICATIONS

**Table 1: WASTE CHAMBER**

CHAMBLER CAPACITY:	600 lbs. Type IV waste (poultry)
CHAMBER VOLUME:	18.9 cubic feet
DOOR DIMENSION:	26" x 30"
HEIGHT TO DOOR:	32.75"
REFRATORY:	3", 2800 <sup>o</sup> f, 126 lbs/cubic feet
JACKET MATERICAL:	14 gauge aluminized steel
HEIGHT TO TOP OF CHAMBER:	34"

**Table 2: STACK & SECONDARY**

DIMINENSIONS:	14" Dia., 96" L
JACKET:	SS 304-2B 16 GA
STACK CAP:	SS 304-2B: 18 GA (14" Dia. X 14" H)
SECONDARY:	ALMZ. STEEL W/ 2800 <sup>o</sup> f REFRACTORY
SECONDARY:	20"Dia, 27"H w/Angle Rings. 1.4 cu ft.

**Table 3: BURNERS**

MODEL: NAT GAS and LP	<b><u>LOWER:</u></b>	One (1) Midco 121-DS Direct Main Flame Spark Ignition Electronic Flame Safety, 100% Shut-offs, 1,200,000 BTUH (maximum)
	<b><u>UPPER:</u></b>	One (1) Midco 83-DS Direct Main Flame Spark Ignition Electronic Flame Safety, 100% Shut-offs, 800,000 BTUH (maximum)
MODEL: OIL	<b><u>LOWER:</u></b>	One (1) Beckett SF Oil Burner W/ Flame Safety, 390,000 BTUH
	<b><u>UPPER:</u></b>	One (1) Beckett AF Oil Burner W/ Flame Safety, 75,000 BTUH
OPERATION:		One (1) 12 Hour Digital Timer

**Table 4: GENERAL**

ELECTRICAL SERVICE:	Standard-110 volt, 60hz, 20 amp, Also available -- 220 volts, 50hz, 10 amp
GAS SERVICE:	Natural Gas: 7" W.C. (with burner s operating) Liquid Propane: 11" W.C. (with burner s operating)
GAS/FUEL CONSUMPTION: Varies by site conditions	Natural Gas = 607 CFH Liquid Propane = 6.62 GPH Fuel Oil = 3.5 GPH
PAD REQUIREMENTS:	12' W x 14' L x 4" D (if sheltered) 8' W x 10' L x 4" D (if not sheltered)
PAINT:	1200 degree primer 1200 degree paint

**Table 5: CHARGING RATE**

PATHOLOGICAL:	Up to 600 lbs. per charge of typical pathological waste with a BTU/lb rating of 1000. Batch loaded allowing complete burn-out, cool down, and ash removal before reloading.
BURN RATE:	Approx. 70lb./hr.

Must be installed in accordance with local codes and ordinances, subject to regulatory agencies. Stack test data is available from the distributor for permit application. If on-site testing is required, it is the responsibility of the purchaser and can be arranged through the distributor. Outside installation is recommended with a simple metal roof or three-sided metal shelter, provided a **minimum** of four (4) foot clearance from any combustible material. Inside installations may have special insurance requirements. Factory must be advised.

## A600 - 2 BURNER PACKING LIST (Subject to change)

### Primary Chamber Components

1	Primary Chamber w/ top & door assembly
2	Counter Weight Arms
8	Counter Weights

### Chamber & Stack Hardware

24	3/8 - 16 x 3/4 bolts
24	3/8 - 16 nuts
4	5/16 -18 nuts
4	5/16 - 18 x 9 bolts
8	5/16ID X 2"OD fender washers
1	Latch
1	Length of Gasket

### Stack & Secondary Components

1	5' SS Stack section
1	3' SS Stack Extension
1	2' refractory lined stack section
1	Stack cap
1	Secondary, refractory lined

### Burner & Hardware

1	Burner Midco J121-DS or Beckett SF
1	Burner Midco J83-DS or Beckett AF
2	Burner covers
1	3/4" Gas cut off valve (NAT Gas and LP only)
1	Pressure gauge (NAT Gas and LP only)
1	Oil filter (oil burner only)
8	1/4 - 20 X 1/2 bolts (oil burner only)
8	1/4 - 20 nuts (oil burner only)
2	Brass flare ell (oil burner only)
1	Brass flare fitting (oil burner only)
2	Brass flare nut (oil burner only)
1	1/4 x 3/8 bushing (oil burner only)
1	1/2 x 3/8 bushing (oil burner only)
1	3/8 x 2 pipe nipple (oil burner only)

# SITE INFORMATION

## *Placement and Construction Recommendations*

- The incinerator is designed for outdoor installation on a concrete slab 6' x 8' x 4" thick. (12' x 14' x 4" if sheltered)
- The incinerator may be installed in a three sided shelter, but must comply with local building and fire codes for clearances from combustible walls and materials. A minimum clearance of 4' around the incinerator is recommended for service and maintenance.
- For recommended construction of a metal chimney through a combustible roof, **See: "Combustible Roof Construction Diagram"** .

## *Electrical Service*

### **115 volts, 60hz, 20 amp for NAT Gas, LP, & Fuel Oil**

- Electrical service can be supplied by plugging into the cord set.
- Upper burner to be wired to lower burner (L1, L2, Ground)

**NOTE:** Polarity must be maintained or the burners will not operate. If burners "lock out" after approximately 5 seconds and the blower continues to operate, then the polarity is incorrect. It should be corrected at the power source, not in the incinerator control.

### **220 volts, 50hz, 10 amp for NAT Gas & LP**

- Electrical service can be supplied through the electrical cord at the burner by adding the type of plug that will fit your application.

### **220 volts, 50hz, 10 amp Fuel Oil only**

1. Loosen the (2) screws and swing open the transformer.
2. Make wire connections as follows:

<u>Electrical Service</u>	<u>Connections at Transformer</u>
L1	Black wire with wire nut
L2	White wire with wire nut

3. Close transformer and tighten screws.
4. Connect the electrical cord from the burner to the timer as follows:

<u>Electrical Cord</u>	<u>Timer terminal</u>
Black wire	L1
White wire	T1



# Fuel Supply

## *NAT Gas and LP*

### **PIPING:**

1. Install gas train with 3/4" minimum dia. pipe or tubing. Larger pipe may be needed depending on the gas supply header and regulator location.
2. Using soap solution, leak test all gas connections.

### **REGULATOR:**

3. Use a properly sized regulator which maintains reduced pressure under static conditions when no gas is flowing. (Dead end lock up).
4. For best results install regulator as near as possible to the incinerator.
5. Regulate LP gas to 11" W.C., NAT gas to 7" W.C. (while burner is burning).
6. Do not exceed 14" W.C. under static conditions when there is no gas flow.

### **PRESSURE GAUGE:**

- A gas pressure gauge is supplied with each incinerator and should be located between the regulator and gas shut off valve, as close to the burner as possible. See below.

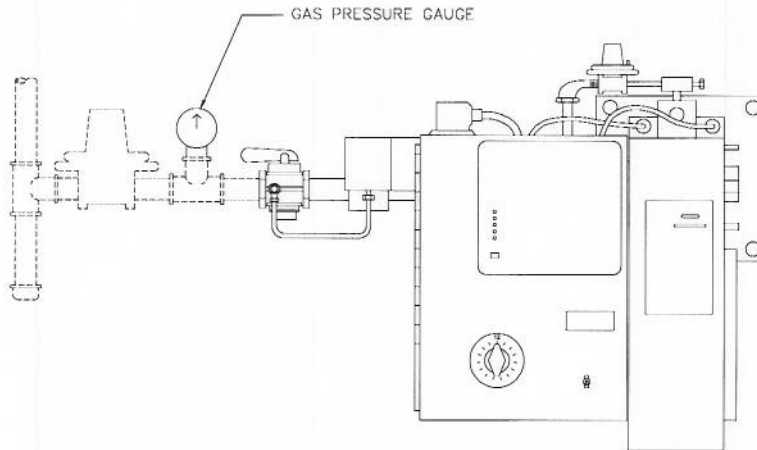

## FUEL SUPPLY (CONTINUED)

### Fuel Oil

#### OIL TANK:

1. Since tanks vary in size and fixtures, you may need to make adaptations to use the parts supplied.
2. It is important that a filter be provided in the line between that tank and the incinerator.
3. If the flow outlet is on the underside of the tank, extend a threaded nipple about 2" into the tank to avoid problems from condensation in the bottom of the tank.

#### PIPING:

1. A flaring tool will be needed to form the ends of the copper tubing.
2. Assemble 3/8" copper tubing, oil filter, shut-off valve and fittings between the oil tank and the burner.

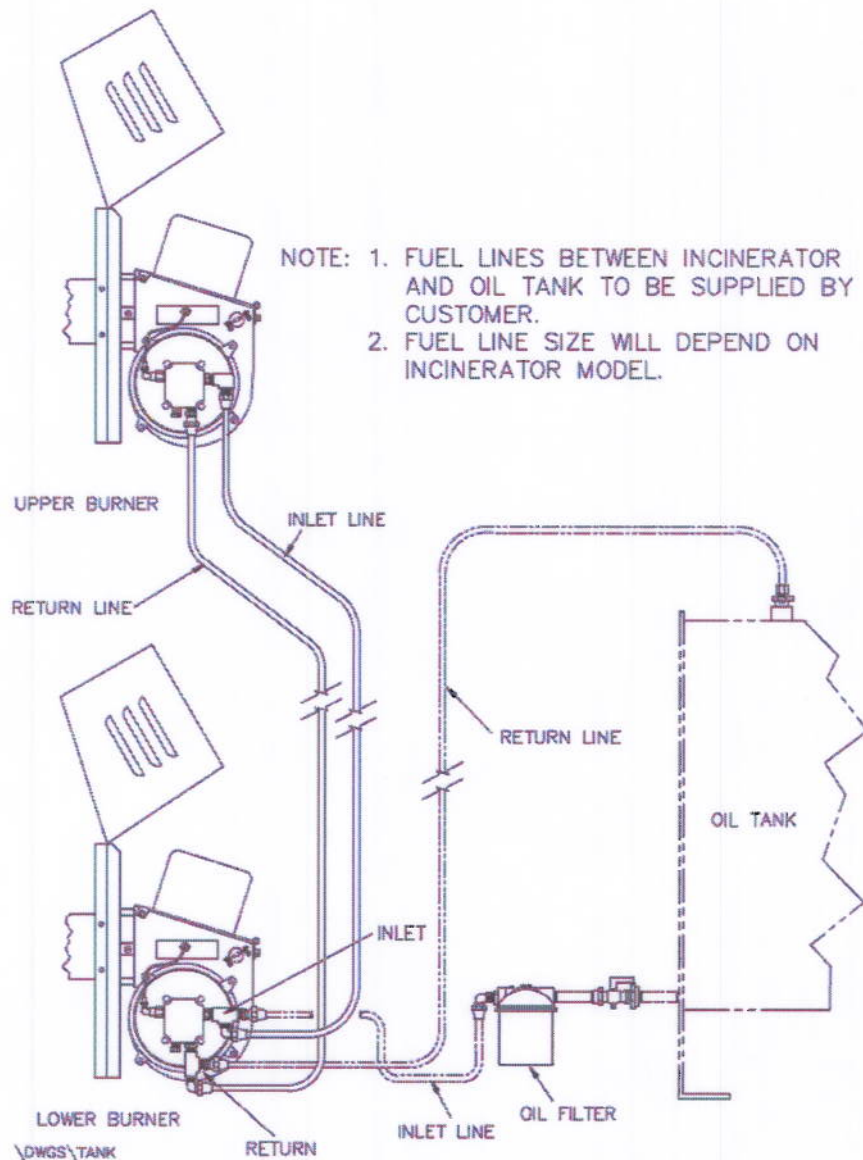



# COMBUSTIBLE ROOF CONSTRUCTION

RECOMMENDED CONSTRUCTION FOR METAL CHIMNEY THROUGH COMBUSTIBLE ROOF

1. DIMENSIONS ARE MINIMUM DISTANCES
2. BASED ON NFPA 82
3. CONSULT LOCAL BUILDING CODES
4. STOCK SHOULD EXTEND NOT LESS THAN 10 FT. HIGHER THAN ANY BUILDING WITHIN 25 FT.

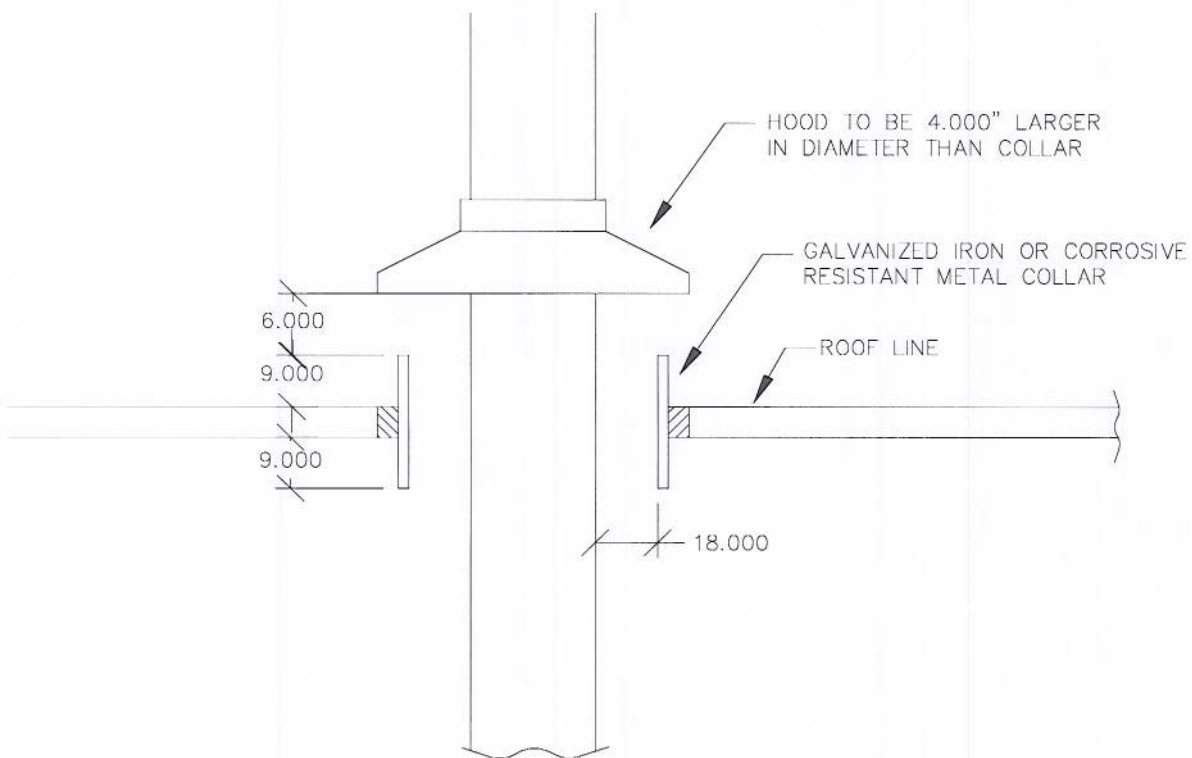

## ASSEMBLY INSTRUCTIONS

1. Position the incinerator on the concrete slab as needed for fuel and electrical hook up.
2. Place the Secondary Chamber above the 2' refractory lined section, burner port aligned with lower burner port, and bolt the flanges together.
3. Slip the 5' stainless steel stack to the Secondary.
4. Slip the collared stainless stack over the lower stack section.
5. Position the stack cap over the top of the stack and secure with (3) #10 X 1/2 sheet metal screws.
6. Bolt the toggle clamp to the primary chamber at the mount bracket using (4) 3/8-16x3/4 flange bolts and (4) 3/8-16 flange nuts.
7. Attached the counter weight arms to the door arms using (6) 3/8-16x3/4 flange bolts and (6) 3/8-16 flange nuts.
8. Bolt the counter weights to the counter weight arms (be sure door is clamped closed) with (4) 5/16-18 x 9 bolts, (4) 5/16 - 18 Nylock nuts and (8) 5/16 X 2 washers.
9. Attach the burner and housing as described below.

For Nat Gas & LP burners - Attach the burner cover and burner to the primary chamber with (4) 3/8-16 flange nuts.

For Fuel Oil Burners -The end of the air tube should be 1/4" back from the inside wall of the combustion chamber. Never allow the leading edge of the head assembly to extend into the chamber. Attach the burner cover to the bracket on the burner with (4) 1/4 - 20 X 1/2 bolts and nuts. Attach the burner to the primary chamber with (4) 3/8-16 flange nuts.

## GAS PRESSURE ADJUSTMENTS

### (for NAT Gas and LP only)

#### **\*PROPER GAS PRESSURE IS CRITICAL TO THE OPERATION OF THE INCINERATOR**

Gas pressure must be adjusted when the burner is operating and set as follows:

**Note:** A gas pressure gauge is supplied with each incinerator (NAT Gas and LP only).

**Nat Gas = 7" W.C.**

**L.P. Gas = 11" W.C.**

# BURNER SETTINGS & AIR ADJUSTMENTS

Table 1: Midco Burner

FUEL	AIR SHUTTER	PILOT ORIFICE	ORIFICE	BTUH
Lower LP	Open*	#52	9/32	530,000
Lower NAT.	Open*	#50	25/64	530,000
Upper LP	Open*	#58	7/64	75,000
Upper NAT.	Open*	#55	5/32	75,000

\*The air shutter is adjusted to the FULL OPEN position from the factory and should never be moved.

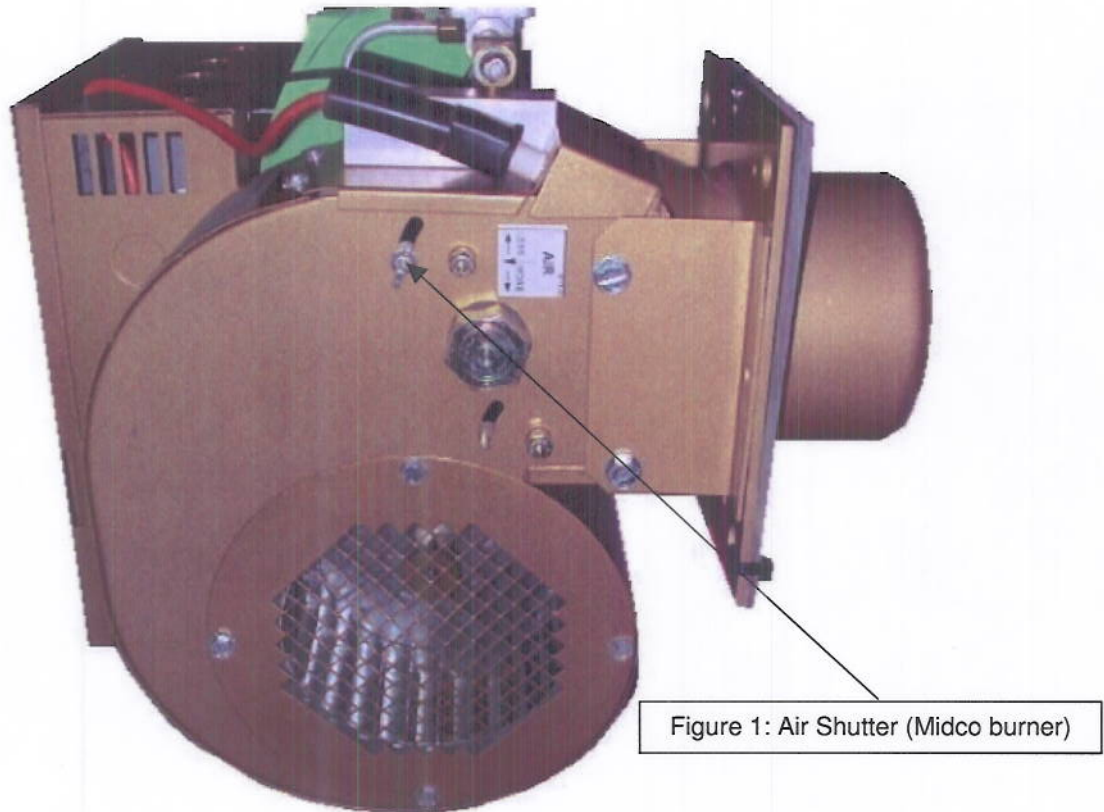

## BURNER SETTINGS & AIR ADJUSTMENTS (continued)

Table 2: Beckett AF & SF Burner

FUEL	AIR SHUTTER	AIR BAND	NOZZLE	RETENTION HEAD	BTUH
Lower #2 Fuel Oil (Diesel)	Closed **	#8 **	3.0 GPH 30 degrees A	F31	410,000
Upper #2 Fuel Oil (Diesel)	Closed **	#8 **	0.65 GPH 70 degrees A	F31	85,000

\*\*These openings are approximate. Final adjustments may be necessary at installation.

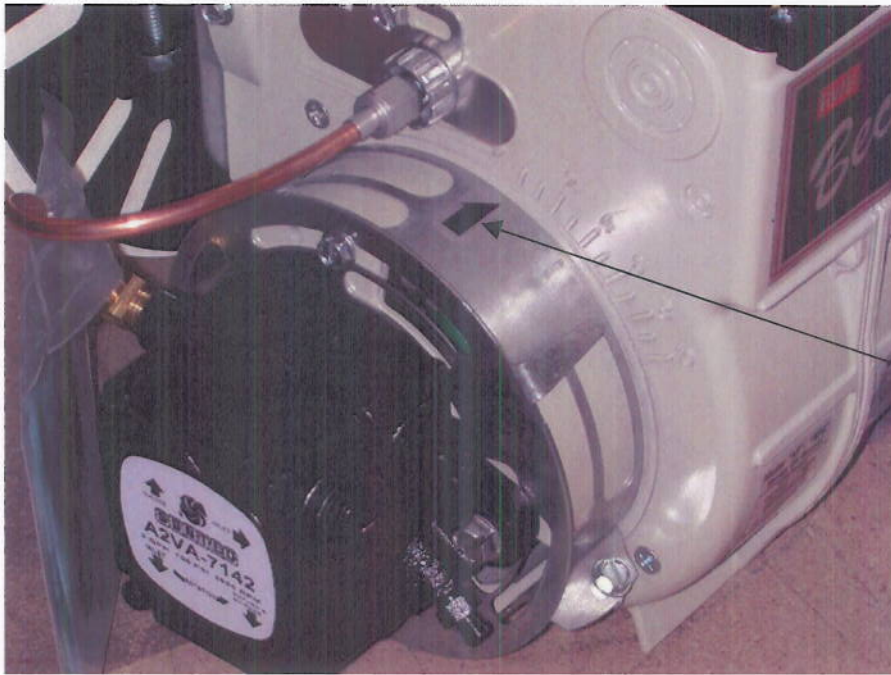

Air Band indicator  
(Beckett burner)



Air Shutter indicator  
(Beckett burner)

## OPERATING INSTRUCTIONS

### DIGITAL TIMER OPERATION

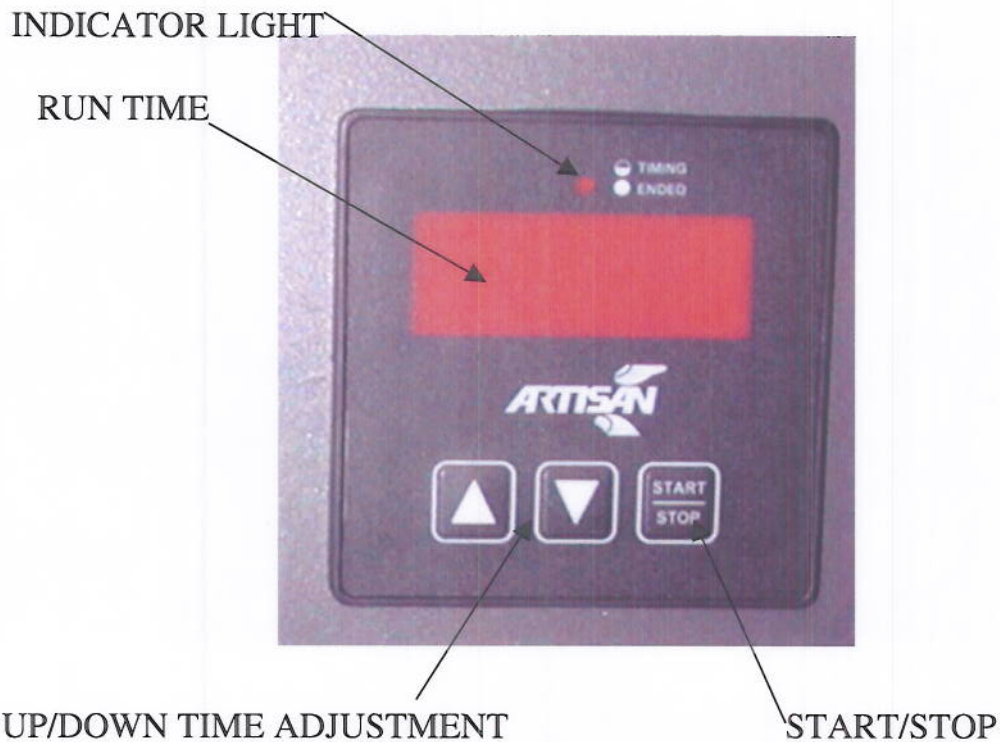

Start burner by setting the Timer for the desired hours of burn time. Press Start, this will start the burner. A full load may need 6 to 8 hours depending on many factors like frozen animals, outside temperature, fatty content of load. Experience will show how to predict the time and achieve a burn as complete as desired.

## Operating instructions

**Curing of the refractory has been factory done. If any new refractory is added later it is essential to cure prior to burning the first load of waste. See "REFRACTORY CURING PROCEDURE" table.**

1. Remove ashes before loading the incinerator.
2. Load incinerator. Keep the waste 6"-8" away from the burner port.
3. Start burner by setting the timer for the desired burn time. A full load will normally burn out in 4 - 5 hours.
4. The incinerator will automatically shut off when the burn is completed.
5. For best results, burn daily to a white ash.

## REFRACTORY CURING PROCEDURE

Table 1: REFRACTORY CURING PROCEDURE

Procedure	Time
Start burner and burn for	5 minutes
Allow to cool for	15 minutes
burn	5 minutes
cool	15 minutes
burn	15 minutes
cool	15 minutes
burn	15 minutes
cool	15 minutes
burn	30 minutes
cool	15 minutes
burn	30 minutes
cool	15 minutes
burn	1 hour
cool	15 minutes
burn	1 hour
cool	15 minutes
burn	1 hour
cool	15 minutes
burn	2 hour
cool	15 minutes
burn	3 hours
Total Time	12 hours(approximate)

There will be hairline cracks and minor scaling of the refractory when curing is complete. This is a normal result of the curing process.

**There will be hairline cracks and minor scaling of the refractory when curing is complete. This is a normal result of the curing process.**

# TROUBLE SHOOTING

## *Nat Gas & LP Models*

### **No spark at electrodes**

1. Is burner blower operating? Possible defective blower motor.
2. Clean electrodes and pilot igniter assembly. Apply heat if moisture is present.
3. Check electrode position. See drawing in Midco manual for proper adjustment.
4. Defective Honeywell Control Board. Check voltage to 25V terminal on board.
5. Check service breaker, timer, electrical connections, and polarity.

### **Spark but no ignition**

6. Confirm gas pressure. LP gas @ 11" WC or NAT gas @ 7" WC.
7. Clean electrodes and pilot igniter assembly. Apply heat if moisture is present.
8. Check electrode position. See drawing in Midco manual for proper adjustment.
9. Listen to confirm that solenoid gas valve is opening. Possible defective gas valve.
10. Check for dirt in brass pilot orifice tee.

### **If incinerator does not burn properly**

11. Have the ashes been removed at the beginning of the day?
12. Be sure there is no obstruction blocking the burner tube.
13. Is the air shutter in the full open position? See diagram in "BURNER SETTINGS" section of this manual.
14. Check gas pressure while the burner is burning. LP gas @ 11" WC or NAT gas @ 7" WC.

## *Fuel Oil Models*

### **No spark at electrodes**

1. Be sure there is no obstruction in the end of the burner tube and there is no soot build-up on the retention head, electrodes or nozzle.
2. Check all electrical connections.
3. Transformer may be burned out. Listen or look to see if there is an arc across the electrodes. Replace transformer if no spark is present.
4. Check for damage to electrodes.
5. Improper firing head adjustment. See Beckett burner installation manual.

### **No oil spray through nozzle**

6. Defective motor. Check to see if blower wheel is turning. If not, check electrical connections and voltage to motor.
7. Air in fuel line. Check all fittings between burners and at fuel tank for tightness. Air may be bled from the fuel line at the fuel pump.
8. Dirt or water in oil tank.
9. Check the plastic coupling between motor and pump for tight fit.
10. Check for clogged filter at tank or on nozzle.
11. Be sure there are no kinks in the oil line.
12. Check the tubing between the pump and nozzle for blockage.
13. Defective pump.

### **If incinerator does not burn properly**

14. Have the ashes been removed at the beginning of the day?
15. Be sure there is no obstruction blocking the burner tube.
16. Are the air bands adjusted correctly? (See "BURNER SETTINGS" section in this manual).
17. Is No. 1 Fuel Oil (Kerosene) or No. 2 Fuel Oil (Diesel) being used as fuel?

# MIDCO BURNER (J121-DS) EXPLODED VIEW

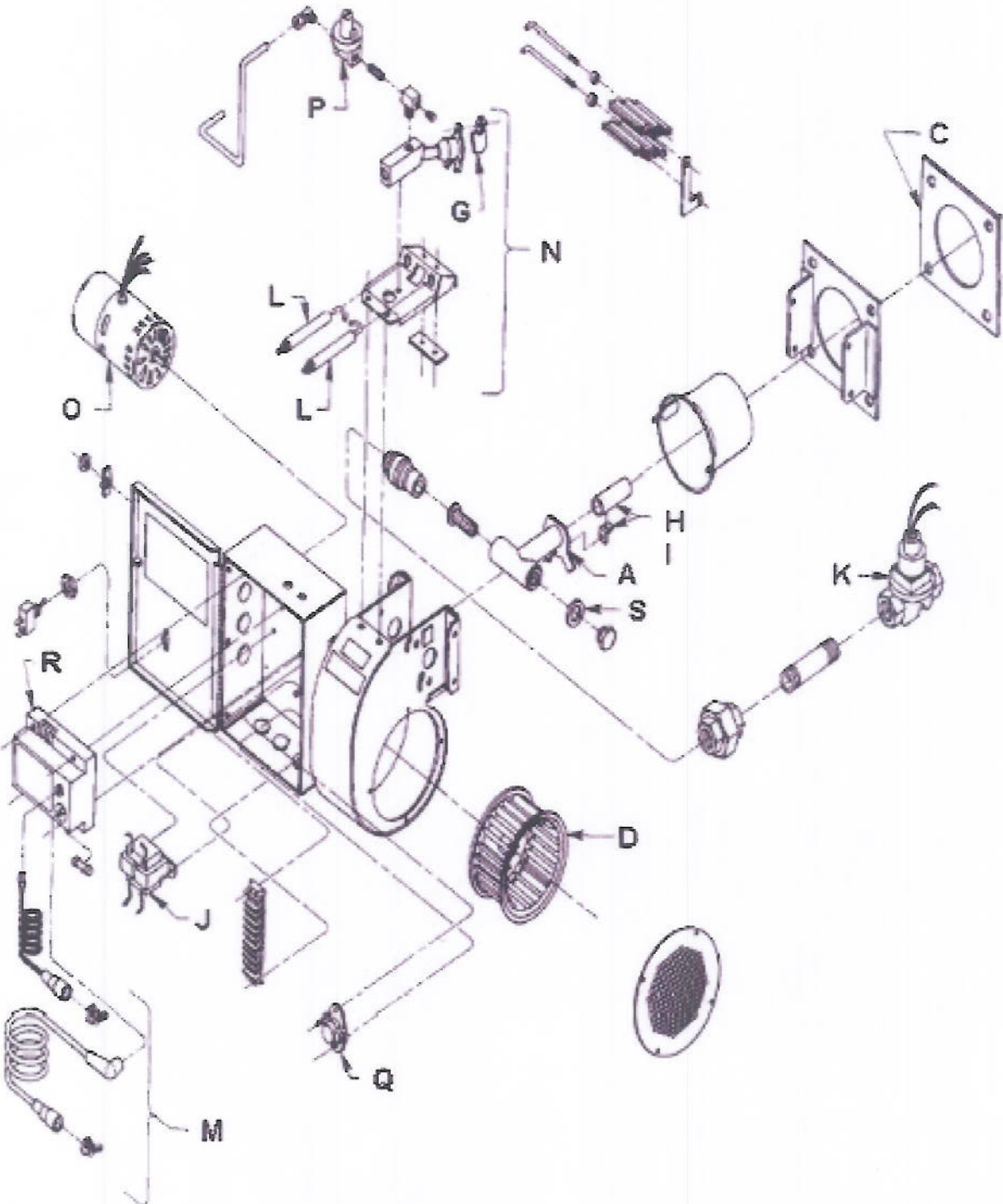

See parts list on following page.  
CTB A600 Dual Burner 2.24.15.doc



## PARTS LIST: MIDCO burner (J121-DS)

Key	Part Number	Description
A	33116	Manifold
C	31603	Flange Gasket
D	33125	Blower Wheel
G	33140	Ground Barrier Kit
H	33113	Main Gas Port and Tube Kit – PROPANE
I	31581	Main Gas Port and Tube Kit – NATURAL
J	33129	Transformer 115/1/50-60 Primary, 24V-30VA Or
	101420	Transformer 220/24V 50/60 Hz, 35VA
K	33109	3/4" NPT Gas Valve -- 24 Volt
L	33121	Electrode (spark or flame) - 2 required
M	33138	Electrode Wires, Boots and Strain Reliefs
N	33131	Ignitor Assembly
O	31579	Motor, 115/1/50-60 Hz Or
	101426	Motor, 220/1/60 Hz
P	33112	Ignitor Regulator 1/8 NPT
Q	33120	Thermal Switch
R	33151	DSI Electronic Control Board
	42200190	Digital Timer 120v
	42200191	Digital Timer 230v
S	33118	Input Adjuster Sealing Gasket
Not Shown	33136	PROPANE Conversion Kit
Not Shown	33135	NATURAL Conversion Kit

# MIDCO BURNER (J83-DS) EXPLODED VIEW

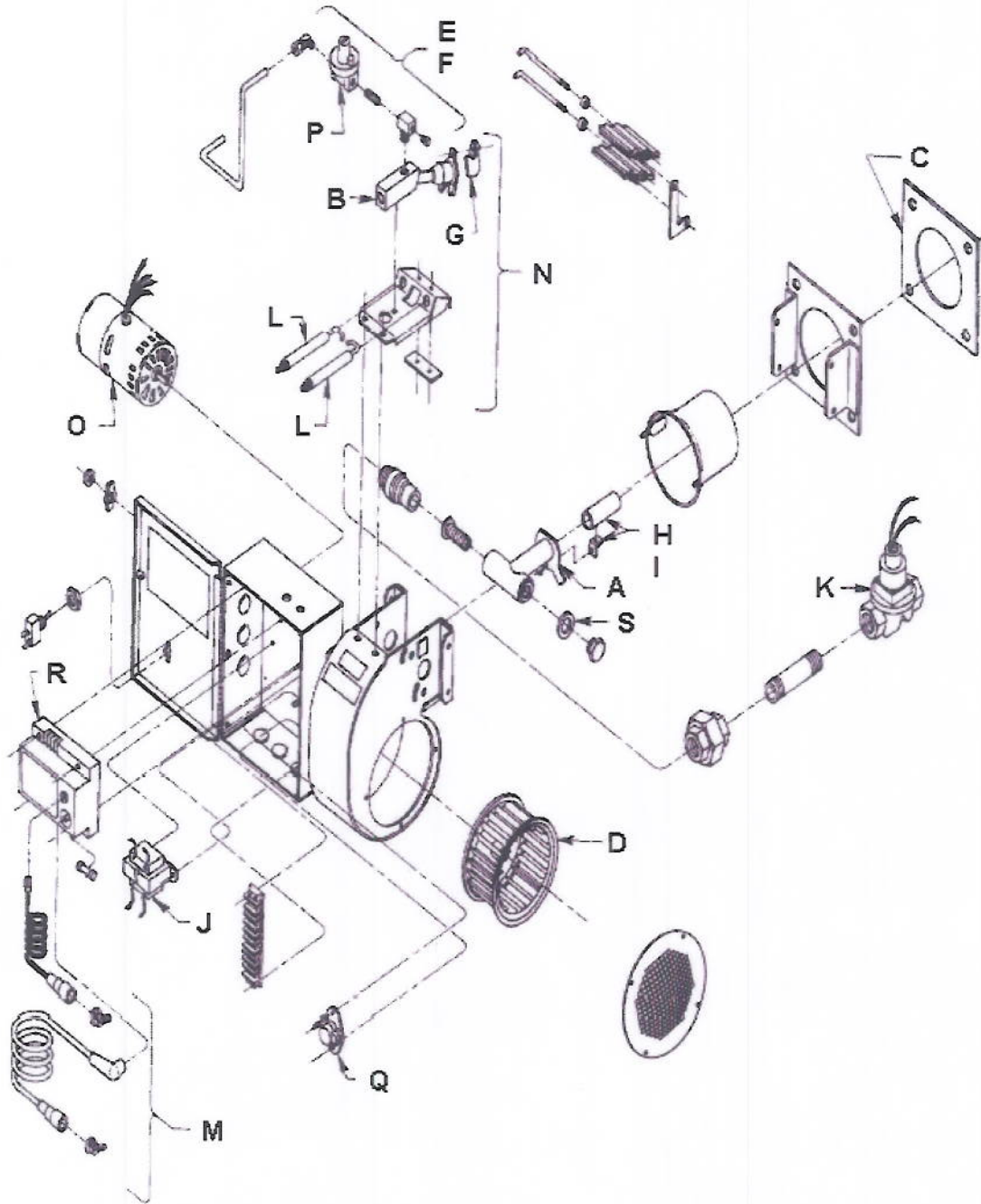

See parts list on following page.

## PARTS LIST: MIDCO BURNER (J83-DS)

Key	Part Number	Description
A	33116	Manifold
B	33117	Ignitor Gas Inlet Block, Tube and Ignitor Tip Assembly
C	31603	Flange Gasket
D	33125	Blower Wheel
E	101211	Ignitor Control Piping NATURAL -- #55 Drill (.052)
F	34290	Ignitor Control Piping PROPANE -- #58 Drill (.042)
G	33140	Ground Barrier Kit
H	33113	Main Gas Port and Tube Kit – PROPANE
I	31581	Main Gas Port and Tube Kit – NATURAL
J	33129	Transformer 115/1/50-60 Primary, 24V-30VA
	101420	Or Transformer 220/24V 50/60 Hz, 35VA
K	33109	3/4" NPT Gas Valve -- 24 Volt
L	33121	Electrode (spark or flame) - 2 required
M	33138	Electrode Wires, Boots and Strain Reliefs
N	33131	Ignitor Assembly
O	33126	Motor, 115/1/50-60 Hz
	101426	Or Motor, 220/1/60 Hz
P	33112	Ignitor Regulator 1/8 NPT
Q	33120	Thermal Switch
R	33151	DSI Electronic Control Board
	42200190	Digital Timer 120v
	42200191	Digital Timer 230v
S	33118	Input Adjuster Sealing Gasket
Not Shown	33136	PROPANE Conversion Kit
Not Shown	33135	NATURAL Conversion Kit

# BECKETT BURNER (SF) EXPLODED VIEW

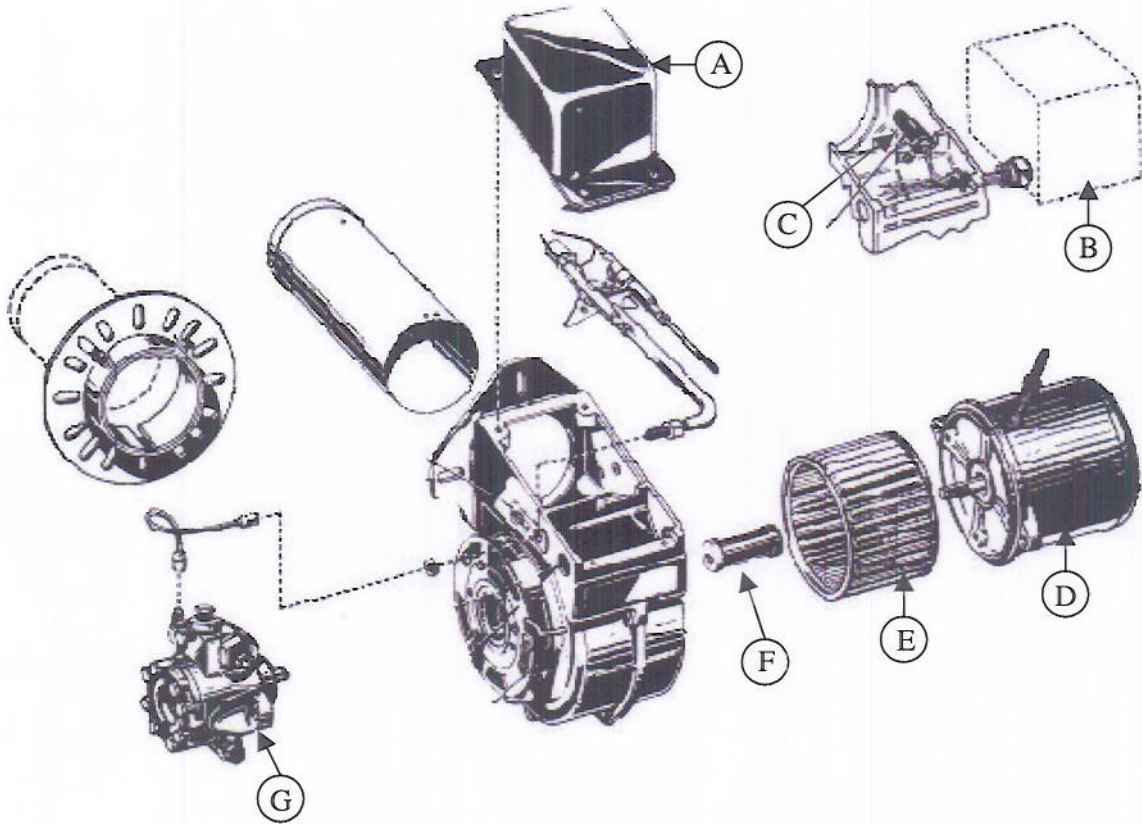

See parts list on following page.

## PARTS LIST: BECKETT BURNER (SF)

Item	Part Number	Description
A	101271 101266	Ignition Transformer 120v/60hz Ignition Transformer 220v/50hz
B	101273 101268	Primary Safety Control 120v/60hz Primary Safety Control 220v/50hz
C	101269	Flame Detector
D	101270 101262	SF Burner Motor 120v/60hz AF Burner Motor 220v/50hz
E	101265	Blower Wheel
F	101263	Flexible Coupling
G	101264	Fuel Pump
Not Shown	101272	Solenoid Valve 120v/60hz
Not Shown	101267	Solenoid Valve 220v/50hz
Not Shown	101332	F310 Retention Head
Not Shown	101472	Connector Tube Assembly
Not Shown	101471	Air Tube Assembly
Not Shown	101473	Nozzle Line Electrode Assembly
Not Shown	101474	Electrode
Not Shown	22137	Nozzle: 2.50 x 30A
	42200190	Digital Timer 120v
	42200191	Digital Timer 230v

# BECKETT BURNER (AF) EXPLODED VIEW

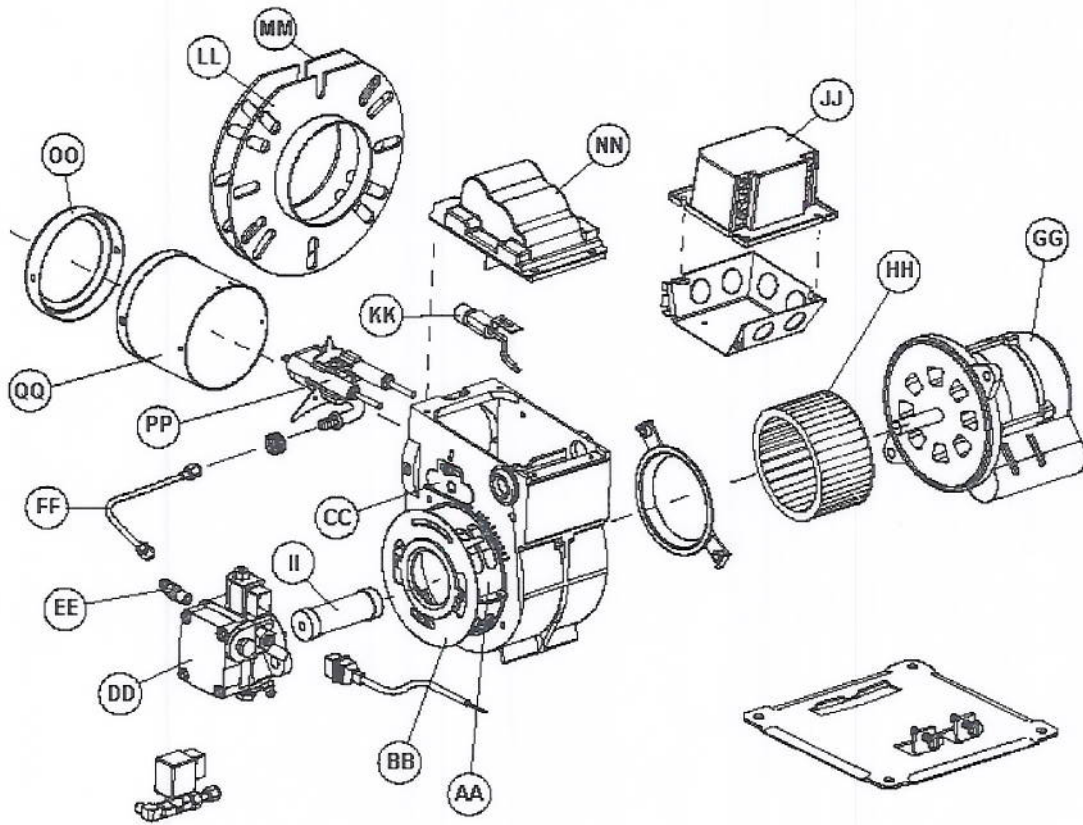

See parts list on following page.

## PARTS LIST: BECKETT BURNER (AF)

Item	Description	Part Number
AA	Air band assembly – 8 slot	32322
BB	Air shutter – 8 slot	52321
CC	Escutcheon plate	32323
DD	Pump A2VA7116 ( <i>Suntec</i> ) 110V 220V	32341 10176130
EE	Pump elbow	57210
FF	Connector tube assembly – 8"	101472
GG	Motor 110V 220V	32302 32303
HH	Blower wheel (use only RWB replacement)	57204
II	Coupling	32340
JJ	Primary Control 110V 220V	----- 101268
KK	Cad cell detector	32345
LL	Flange – universal, adjustable, incl. gasket	32365
	Digital Timer 120v	42200190
	Digital Timer 230v	42200191
MM	Gasket only	32320
NN	Transformer 110V 220V	32310 10173200
OO	Retention head	32335
PP	Electrode kit F head air tubes longer than 9"	101474
QQ	Air Tube	32351
Not Shown	Nozzle: 2.50 X 30A	22134

# A600

- Dual Burner -

36499 STACK CAP: 14" SS Kit

Burners & Housings	
23045	BURNER ASM: A10-20 Upper
23048	BURNER ASM: A600-20 Lower Oil
31559	BURNER ASM: A600-2G LP Lower Complete
88810	BURNER ASM: Upper LP (ITC) A600
31560	BURNER ASM: A600-2G Hat Lower Complete
88811	BURNER ASM: Upper Nat (ITC) A600
20335	BRNR HSG: Oil A6, A10, P9
35004	BRNR HSG: Ag Sec
100725	BRNR HSG: 30 Deg

Miscellaneous Parts	
35024	GAS PRESSURE GAUGE: AG C & PROF 1
34034	REFRCTRY: Mastic 1 Pint, 2-1/2 #
34038	RFRCTRY: 2800 DGR Std Mix
101428	RFRCTRY: High Mod Impact 55# Bag
102665	REFRCTRY: Mastic 1 Gal - 20 #
32313	PAINT: Metallic Brown Spray Can
42200190	TIMER: Artisan w/Gasket

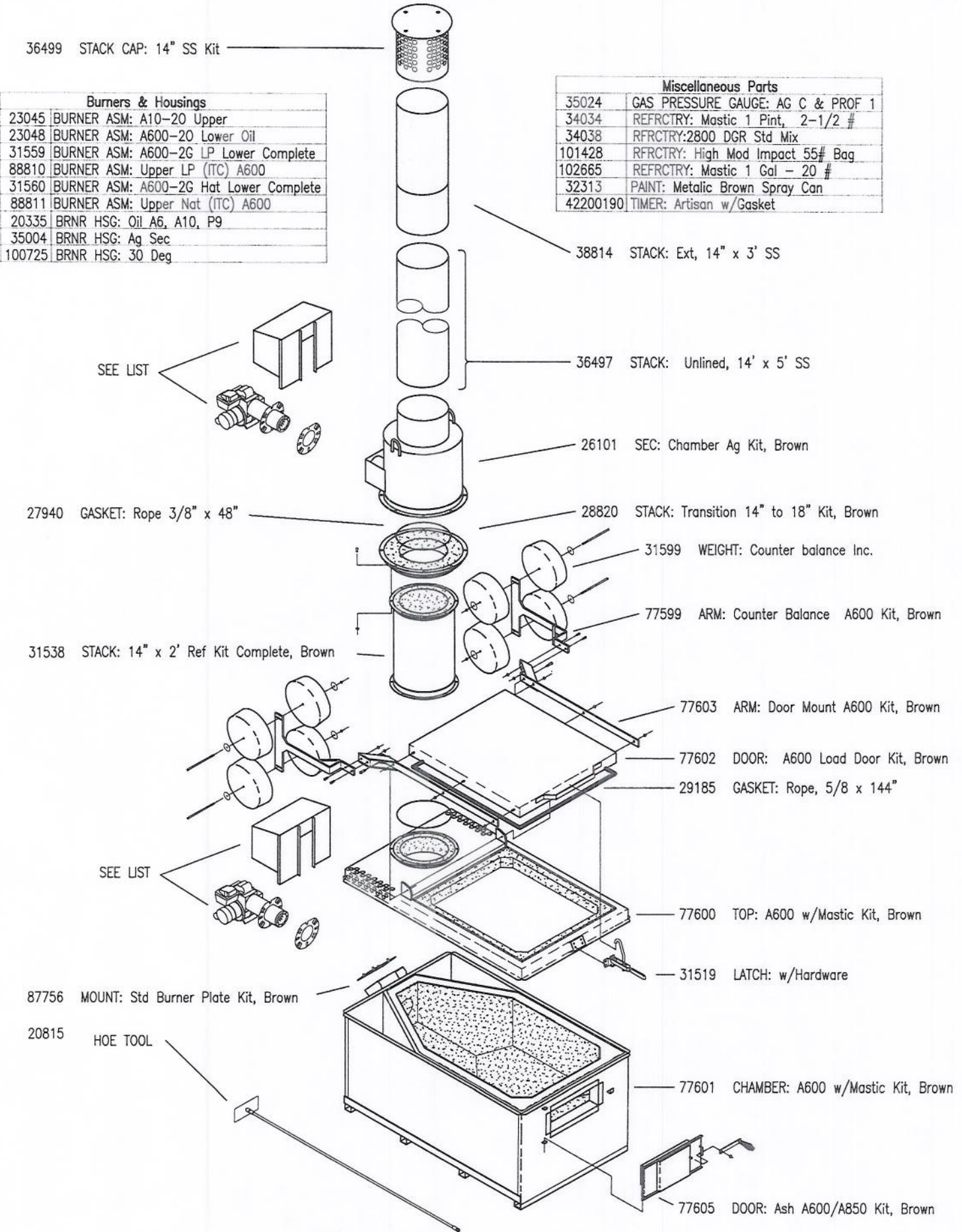

SEE LIST

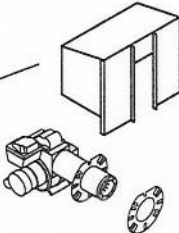

27940 GASKET: Rope 3/8" x 48"

26101 SEC: Chamber Ag Kit, Brown

28820 STACK: Transition 14" to 18" Kit, Brown

31599 WEIGHT: Counter balance Inc.

77599 ARM: Counter Balance A600 Kit, Brown

31538 STACK: 14" x 2' Ref Kit Complete, Brown

77603 ARM: Door Mount A600 Kit, Brown

77602 DOOR: A600 Load Door Kit, Brown

29185 GASKET: Rope, 5/8 x 144"

SEE LIST

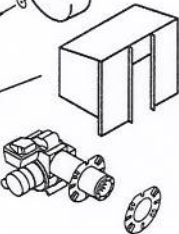

77600 TOP: A600 w/Mastic Kit, Brown

31519 LATCH: w/Hardware

87756 MOUNT: Std Burner Plate Kit, Brown

20815 HOE TOOL

77601 CHAMBER: A600 w/Mastic Kit, Brown

77605 DOOR: Ash A600/A850 Kit, Brown



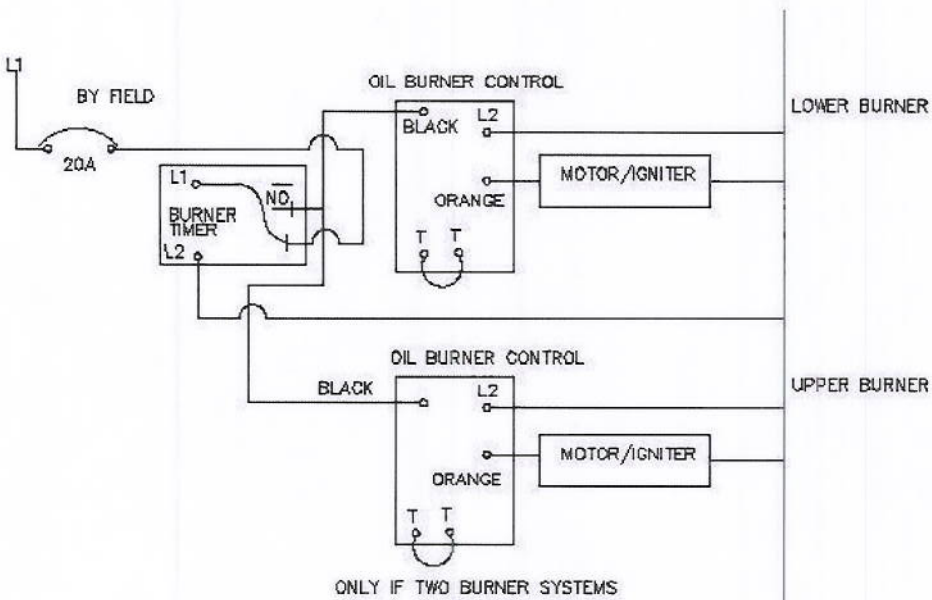
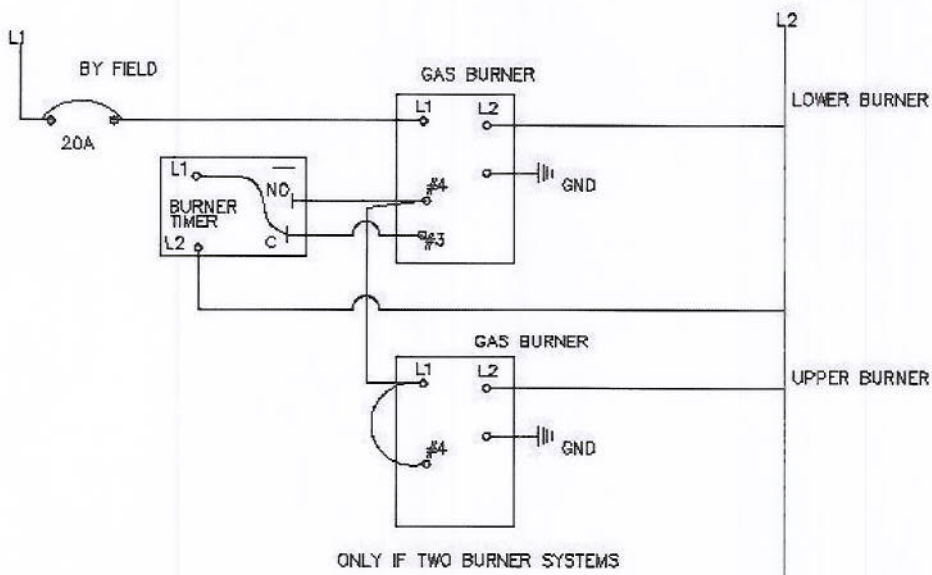

FIRELAKE MFG. L.L.C.  
DASSEL, MN 55325

DATE 1-21-2014  
KC

SIZE

MATL

DESCRIPTION  
WIRING DIAGRAM:

PART NO.  
AG ARTISAN

# 4970

## Configurable Countdown Timer



The 4970 is a highly flexible countdown interval timer with digital display of timing controlling a set of high current output contacts. The timing cycle range can be configured for any of the following values: 00:01-99:59 Minutes:Seconds, 00:01-99:59 Hours:Minutes, 0001-9999 Seconds, and 00.01-99.99 Seconds. The two arrow buttons on the front panel are used to set the time, the Up button increases the time and the Down decreases it. The longer a button is held down the faster the rate at which the time value will change, the time value rolls around at both ends of the time range.

The Start/Stop button performs multiple functions. Pressing the Start/Stop button while the timer is idle will energize the output power relay contacts and the controller begins counting down the time on the display, once the display reaches 0 the contacts de-energize and the unit alarms for 5 seconds and then returns to the original cycle time. Pressing the Start/Stop button while the controller is timing will pause the controller at the current time and de-energize the output relay contacts. Pressing the Start/Stop button while in pause mode causes the output relay to energize and the controller continues timing from the point at which it was paused. Should the Start/Stop switch be held down for longer than two seconds while in pause mode the controller will reset and the display will return to the original starting time.

Should power fall during a timing cycle the controller remembers the last time value and will recover upon restoration of power dependant on its configuration. The 4970 always remembers the last interval time programmed and when first powered up resets to that time. The LED above the 4 digit display flashes during the timing cycle to indicate timing and is on continuously when the cycle is ended. *The 4970 can be configured with a variety of time range, timing adjustment, alarming, power recovery, and power conservation options, see the second page for information.*

### Specifications

**Operating Voltage:** 12VDC -10/+20%, 115VAC ±15%, 230VAC ±15%, 24VAC ±10%, 50/60 Hz for AC.

**Current Consumption:** See table for operating current at nominal input voltages; Idle = display on,

Timing = display & relay on, Standby = display off (option LP:02 selected)

**Timing Accuracy:** ±0.5% of set time.

**LED Digital Display:** Four digit red LED, 0.56" characters.

**Timing Cycle Memory:** All data stored in non-volatile memory, 10 yr. min. retention with no power.

**Audible Alarm:** Solid state alarm operating dependant on unit configuration.

**Output Contact Ratings:** See table below for various load types and voltages.

**Agency Listing:** UL File E47858: Appliance Controls - Component ATN22 (US), ATN26 (Can)

**Mounting:** 2.63 sq. cutout accepts timer which is secured with supplied bracket & nut. Mounting nut must be tightened to 3 Inch pounds.

**Wiring:** .25" Quick Connect terminals.

**Operating Temperature:** 0°C to 70°C.

**Data Sheet Revision Date:** January 23, 2012

**Operating Current (mA)**

	Idle	Timing	Standby
12V DC	55	135	20
115V AC	22	30	19
230V AC	10	15	8.0
24V AC	105	150	95

### Ordering Information

Part Number	Operating Voltage
4970-1	12V DC
4970-2	115V AC
4970-3	230V AC
4970-4	24V AC

**Output Contact Ratings**

	NO Contacts	NC Contacts
<b>Resistive Inductive</b>	20A @ 125/240VAC, 30VDC 6A @ 277VAC	10A @ 125/240VAC, 30VDC 3A @ 277VAC
<b>Motor</b>	2HP @ 240VAC 1HP @ 125VAC	1/2HP @ 240VAC 1/4HP @ 125VAC
<b>LRA/FLA</b>	60A LRA @ 240VAC 20A FLA @ 240VAC	33A LRA @ 240VAC 10A FLA @ 240VAC
<b>Ballast</b>	6A @ 125/277VAC	3A @ 125/277VAC

VISIT OUR WEB SITE AT: [www.artisancontrols.com](http://www.artisancontrols.com)

**Notice:** Artisan Controls Corporation assumes no responsibility for customers applications or product design, it is the customers responsibility to analyze their application and test the selected product to determine its suitability for use. The information and data contained herein is the sole and exclusive property of Artisan Controls Corporation. Any duplication, misuse, or conversion of this information without the express written consent of Artisan Controls Corporation is illegal and will result in damages including court costs and attorney fees being assessed against the party misusing this property

**Tel: 973-598-9400 • Fax: 973-598-9410 • Toll Free: 800-457-4950**

**Artisan Controls Corporation, 111 Canfield Ave. Bldg B15-16, Randolph, New Jersey 07869, USA**

## Mechanical

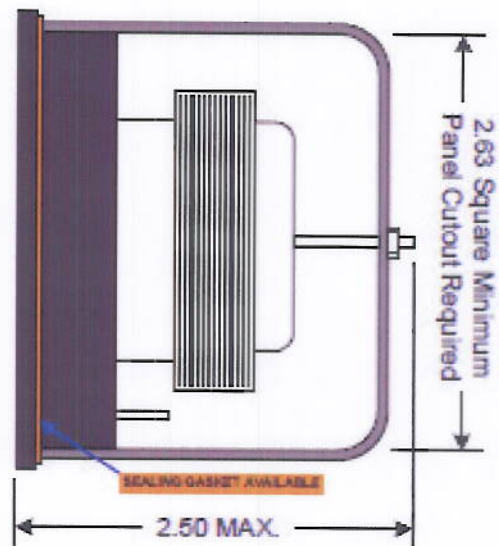
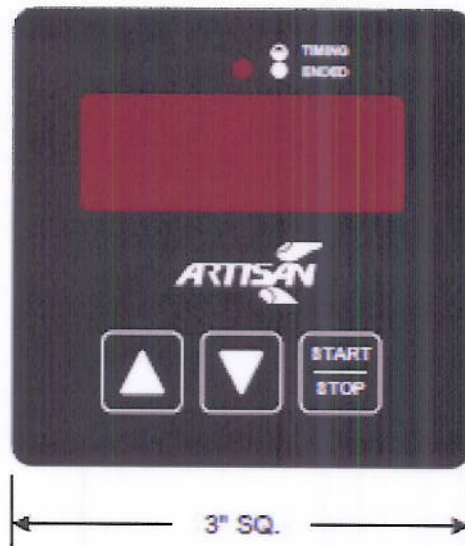

## Wiring

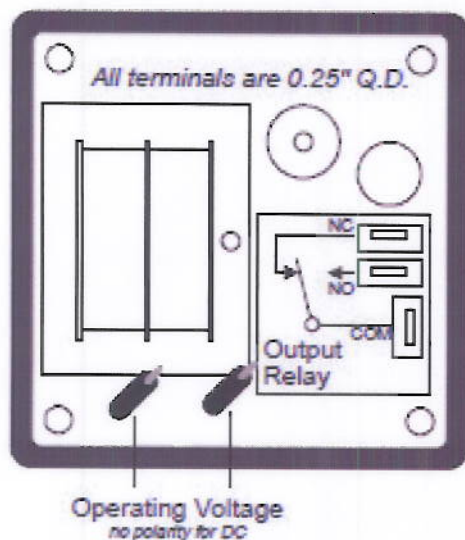

## Configuration

The 4970 can be configured to any of four time ranges by performing the following. Press and hold the down button (center) and apply the power. The unit will display one of the four ranges per this chart

- 0 = 00.01 - 99.99 seconds
- 1 = 00:01 - 99:59 minutes:seconds
- 2 = 0001 - 9999 seconds
- 3 = 00:01 - 99:59 hours:minutes

To change the timing range use the up and down buttons to change the displayed value to the range desired, then turn the controller off. The next time the controller is turned on it will be operating in the selected time range.

More detailed configurations such as styles of beeping and limiting the time range are available by using the Start/Stop button in a similar manner, please refer to the 4970 Users Manual for details

VISIT OUR WEB SITE AT: [www.artisancontrols.com](http://www.artisancontrols.com)

**Notice:** Artisan Controls Corporation assumes no responsibility for customers applications or product design, it is the customers responsibility to analyze their application and test the selected product to determine its suitability for use. The information and data contained herein is the sole and exclusive property of Artisan Controls Corporation. Any duplication, misuse, or conversion of this information without the express written consent of Artisan Controls Corporation is illegal and will result in damages including court costs and attorney fees being assessed against the party misusing this property

**Tel: 973-598-9400 • Fax: 973-598-9410 • Toll Free: 800-457-4950**  
**Artisan Controls Corporation, 111 Canfield Ave. Bldg B15-18, Randolph, New Jersey 07868, USA**