



- Instructions for the user
- Components
- Installation instructions

# Side Belt Nest Systems

# TABLE OF CONTENTS

Disclaimer .....	3
General information .....	4
INSTRUCTIONS FOR THE USER PART I.....	7
General Safety Rules .....	8
Hand Winch General Safety Rules .....	9
Hand Winch Trouble Shooting Guide .....	10
COMPONENTS PART II .....	11
20 Hole Side Belt w/Auto lid .....	12
16 Hole Side Belt w/Auto lid .....	14
Passageways .....	15
Hole Kits .....	16
SB Nest Lid Closer System .....	17
INSTALLATION INSTRUCTIONS PART III .....	18
Hand Winch General Safety Rules .....	19
Hand Winch Trouble Shooting Guide .....	20
Step by Step Assembly of Nest .....	21
Nest line Alignment.....	34
End Return Roller Assembly.....	35
Step by Step Assembly of Nest Lid Auto-Close .....	36
Plastic Egg Belt Splice w/Lacing .....	44

*Made to Work. Built to Last.*<sup>SM</sup>  
**P.O. Box 2000 State Road 15 North**  
**Milford, IN. 46542-2000 U.S.A.**  
**574-658-4101 Fax 877-730-8825**  
**[www.ctbinc.com](http://www.ctbinc.com)**

Made in the U.S.A.

**Note:** The original, authoritative version of this manual is the English version produced by CTB, Inc. or any of its subsidiaries or divisions, (hereafter collectively referred to as "CTB"). Subsequent changes to any manual made by any third party have not been reviewed nor authenticated by CTB. Such changes may include, but are not limited to, translation into languages other than English, and additions to or deletions from the original content. CTB disclaims responsibility for any and all damages, injuries, warranty claims and/or any other claims associated with such changes, inasmuch as such changes result in content that is different from the authoritative CTB-published English version of the manual. For current product installation and operation information, please contact the customer service and/or technical service departments of the appropriate CTB subsidiary or division. Should you observe any questionable content in any manual, please notify CTB immediately in writing to: CTB Legal Department, P.O. Box 2000, Milford, IN 46542-2000 USA.

# GENERAL INFORMATION

**THESE INSTRUCTIONS MUST BE READ, UNDERSTOOD AND ALL POINTS OBSERVED BY THE USER, THE RESPONSIBLE AND OPERATING PERSONNEL.**

## 1. OBEY THE LEGAL REGULATIONS AND THE APPLICABLE RULES!

This concerns, among other things, directives transposed into national legislation and/or the laws, safety and accident prevention regulations that apply in the user's country.

During assembly, operation and maintenance of the installation the legal regulations concerned and the applicable technical rules must be obeyed.

## 2. INTENDED USE

The installation has been designed solely for intensive livestock use and has been developed according to the applicable rules of good workmanship. Extra loading of the product is therefore prohibited. Any other use is considered to be improper use. The manufacturer is not responsible for damage resulting there from. The user bears sole responsibility.

## 3. NOT-INTENDED USE

All use different than described in point 2" intended use" is at the responsibility of the end user.

## 4. LIABILITY

The (Extended) Warranty will not apply if any of the following has occurred: failure to conduct incoming goods inspection with regards to the Products, improper handling, transportation, modification or repair; accident, abuse or improper use; improper assembly, installation, connection or maintenance (having regard to Chore-time's most current assembly, installation, connection and maintenance manuals); force majeure; negligence, lack of supervision or of maintenance on the part of customer; normal wear and tear; use of cleansing agents and disinfectants that are excluded in Chore-Time's most current use and maintenance manuals; use of cleansing agents and disinfectants in violation with the instructions received from the suppliers; or use of the Products in an ATEX-surrounding.

The (Extended) Warranty shall not apply in the event of a defect caused either by materials or accessories supplied by or services rendered by Customer; or by an intervention by a person or entity which is not authorized or qualified for carrying out such intervention. Furthermore, the (Extended) Warranty will only apply if the Products are used in livestock houses and if all parts or components of the Products are supplied by Chore-Time.

Chore-Time will not be liable for any damages caused due to improper use, assembly, installation, connection or maintenance of the Products. In this respect, the Customer expressly acknowledges that (i) all use, assembly, installation, connection or maintenance must be done in accordance with Chore-Time's most current assembly, installation, connection and maintenance manuals and (ii) the electrical installation on which the Products must be connected must be done in accordance with applicable local legislation on electrical installations. Furthermore, the Products must be tested both mechanically and electrically in accordance with state of the art techniques and applicable local legislation.

## 5. PERSONNEL QUALIFICATIONS

### USER:

The person who uses a function or operation of a product for their work or who works on the product. The user must be able to read the instructions for use and fully understand them. The user has knowledge of the functioning and construction of the installation.

### TECHNICALLY TRAINED PERSON:

An expert who can assemble and maintain the installation (**mechanically/electrically**), and resolve malfunctions. On the basis of his/her technical training and experience, he/she has sufficient knowledge to be able to assess activities, recognize possible dangers and rectify dangerous situations.

## 6. INFORMATION ABOUT THE RESIDUAL RISKS - USED SAFETY SIGNS





There are three levels of danger, which you can recognize from the signal word

\* **DANGER**

\* **WARNING**

\* **CAUTION**

The nature and source of the imminent danger and possible consequences of not obeying warnings is stated here!

 <b>DANGER</b>	<p><b>DANGER</b> indicates a direct imminent danger that can result in a serious or even fatal accident if the safety measures are not respected.</p>
 <b>WARNING</b>	<p><b>WARNING</b> indicates a possible imminent danger that can result in a serious accident or damage to the product if the safety measures are not respected.</p>
 <b>CAUTION</b>	<p><b>CAUTION</b> indicates possible, dangerous situations that can result in minor physical injury or material damage if the safety measures are not respected.</p>
	<p>This symbol refers to supporting information.</p>
<p> <input checked="" type="checkbox"/> allowed  <input type="checkbox"/> not allowed         </p>	

## 7. STORAGE

Put all parts to be assembled in a room or at a location where the not yet assembled components are protected against weather influences.

## 8. TRANSPORT

Depending on the size of the parts and according to local circumstances and local legislation, the parts of the machine have to be transported with a forklift.

The forklift must be operated by a qualified person and in accordance with the rules of good workmanship.

When lifting the load, always check if the center of gravity of the load is stable.

## 9. DISMANTLING

Dismantle the installation and its components in accordance with the environmental legislation of the country or the local authorities applicable at that time. All functioning products and exchange parts must be stored and disposed of in accordance with the applicable environmental regulations.

### Environmental information



This symbol indicates that the product must be disposed of separately. You are yourself responsible for the destruction of this and other electrical and electronic equipment via the disposal channels designated for that purpose by the national or local government. The correct destruction and recycling of this equipment prevents any negative consequences for the environment and health. For more information about destroying your old equipment, contact your local authorities or waste disposal service.

## Information about waste disposal - electrical/electronic material for companies

### 1. In the European Union

If you have used the product for commercial purposes and you want to dispose of it, contact Chore-Time who will give you information about the return of the product. It is possible that you will have to pay a disposal charge for the return and recycling. Small products (and small quantities) can be processed by the local collection agencies.

### 2. In other countries outside the European Union

If you want to dispose of this product, contact the local authorities for information concerning the correct disposal procedure.

## 10. THE LEVEL OF NOISE EMISSION

The noise level of the installation in operation does not exceed 70dB(A).

## 11. LOCK OUT TAG OUT – LOCK METHOD GENERAL

- Everyone needs his own lock and tag (label), which can't be removed by other persons.
- Inform all persons who are influenced by the procedure.
- Localize all sources of energy (electric, hydraulic, pneumatic).
- Switch off.
- Lock out and tag out.
- Check if the source of energy is switched off.
- Remove any remaining energy.

## 12. USE PERSONAL PROTECTIVE EQUIPMENT.

Ensure you wear personal protective equipment (gloves, dust masks...).

## 13. SUFFICIENT LIGHTING - ILLUMINANCE

- **A minimum illuminance of 200 lux is necessary** during usage, maintenance and installation.
- Provide at the installation **(portable) emergency lighting in case of power failure.**

## 14. ELECTRICAL EQUIPMENT, CONTROL PANELS, COMPONENTS AND DRIVE UNITS

- To operate control panels, there must be **at least 70 cm of free space.**
- Control panels must **always remain closed.** The key of the control panel must be in possession of an authorized person.
- The necessary measures must be taken by the user to keep out **rats, mice and other vermin from the control panels**
- If electrical equipment, control panels, components and drive units are damaged, the system must be stopped **IMMEDIATELY!**
- Electrical equipment, control panels, components and drive units should **NEVER be sprayed with water or other liquid!**
- Electrical equipment, control panels, components and drive units should **NEVER be covered with any material.**

## 15. TAKE NECESSARY PRECAUTIONS WHEN WORKING WITH SHEET METAL, EDGES MAY BE SHARP

- This guide will address the assembly of and part identification for the revised side belt nest of common 6 partition design. This guide will also include attachment of and part identification for the passageway.

# **PART I**

## **INSTRUCTIONS FOR THE USER**

## General Safety Rules



**WARNING:** Improper installation, adjustment, alteration, service or maintenance can cause property damage, injury or death. Read the installation, operating and maintenance instructions thoroughly before installing or servicing the equipment.



**DANGER!** Take necessary precautions when working with sheet metal, edges may be SHARP!



**DANGER!** Shock hazard exists! Disconnect all power before opening enclosure for servicing. Allow 5 minutes' power off for capacitor to discharge on circuit board. Control must be grounded.



**Read assembly guide completely before beginning setup. For most efficient assembly, two people should work together.**





HAND WINCH  
GENERAL SAFETY RULES

Hand winch for nesting lines for poultry



DANGER

**IMPORTANT**

Carefully read the following instructions before  
USING the system

1. **PAY ATTENTION** when **WINCHING UP** or **WINCHING DOWN** the nests:
  - **STOP** the handling in case of any malfunctioning.
  - **NEVER** stand **UNDERNEATH** the load when winching up or putting down the nests.
2. **NEVER ALLOW UNAUTHORIZED PERSONS ENTER** the house during your absence.
3. **DON'T** wear **loose** clothing.
4. Only **adults** may handle the hand winch.
5. Only use the hand winch for **suspension of a CHORE-TIME nesting line**.
6. Only use the hand winch with the **supplied handle**.
7. **ALWAYS** check the **condition of the hand winch and the cable** before operating.  
A **ravelled, kinked or damaged cable** must be replaced **IMMEDIATELY**.  
A **loose or damaged hand winch** must be replaced **IMMEDIATELY**.
8. **ALWAYS** check before use, if the **cable on** the drum weldment is ok.
9. **ALWAYS** check before use, if the **cable is not damaged**.
10. **ALWAYS** check that there are **at least 4 cable windings** on the drum weldment.
11. **NEVER** touch the **cable** and the **rotating parts** of the hand winch when in use.
12. Only use the hand winch when **NOBODY** is standing **underneath the load**.
13. **ALWAYS** look **at the load** while using the hand winch.
14. Always turn the handle **fluently**.
15. **PREVENT** that the load makes a **shocking movement**.
16. **Don't use water** to clean the hand winch.



**FORBIDDEN: NEVER** use the hand winch to lift persons.



**DANGER:** Getting jammed by the handle

## HAND WINCHING TROUBLE SHOOTING GUIDE



**Not respecting above-mentioned instructions can cause physical injury or material damage.  
Use personal protective equipment.**

**ACTIONS IN GREY BACKGROUND MUST BE DONE BY A TECHNICALLY TRAINED PERSON.**



**SEE TO IT THAT YOU FIRST REMOVE EACH ELEMENT WINCH CAN OBSTRUCT A SAFE OPERATION OF THE SYSTEM!**

PROBLEM	CAUSE	CORRECTIVE ACTION
1. Brake doesn't work	a. Screw thread on the drive shaft or the handle is damaged.	-Replace the hand winch.
	b. Screw thread on the drive shaft or the handle is dirty.	-Clean the hand winch dry.
		-When not OK, please ask a technically trained person.
	c. Brake discs are dirty.	-Clean the hand winch dry.
-When not OK, please ask a technically trained person.		
2. Winching doesn't work	a. Load is too heavy.	-limit the load till max 300 kg.
	b. Cable to the load is blocked somewhere.	-Release the cable.
	c. Drum weldment or drive shaft of the hand winch is blocked because of dirt or rust.	-Clean the hand winch and grease when necessary.
		-Clean the hand winch and grease when necessary.
3. Putting down the load doesn't work.	a. Safety lock is switched on.	-Take the handle and unlock the safety lock.
	b. Cable to load is blocked somewhere.	-Release the cable
	c. Drum weldment or drive shaft of the hand winch is blocked because of dirt or rust.	-Clean the hand winch and grease when necessary.

### MAINTENANCE INSTRUCTIONS



**Use personal protective equipment**

- Remove all dirt and dust after each batch or at least every 6 months.
- See to it that the handle turns fluently on the crew thread of the main shaft.
- Don't use water to clean the hand winch.
- Use grease to grease moving parts.

**PART II**

**COMPONENTS**

61911204 CHORE-TIME

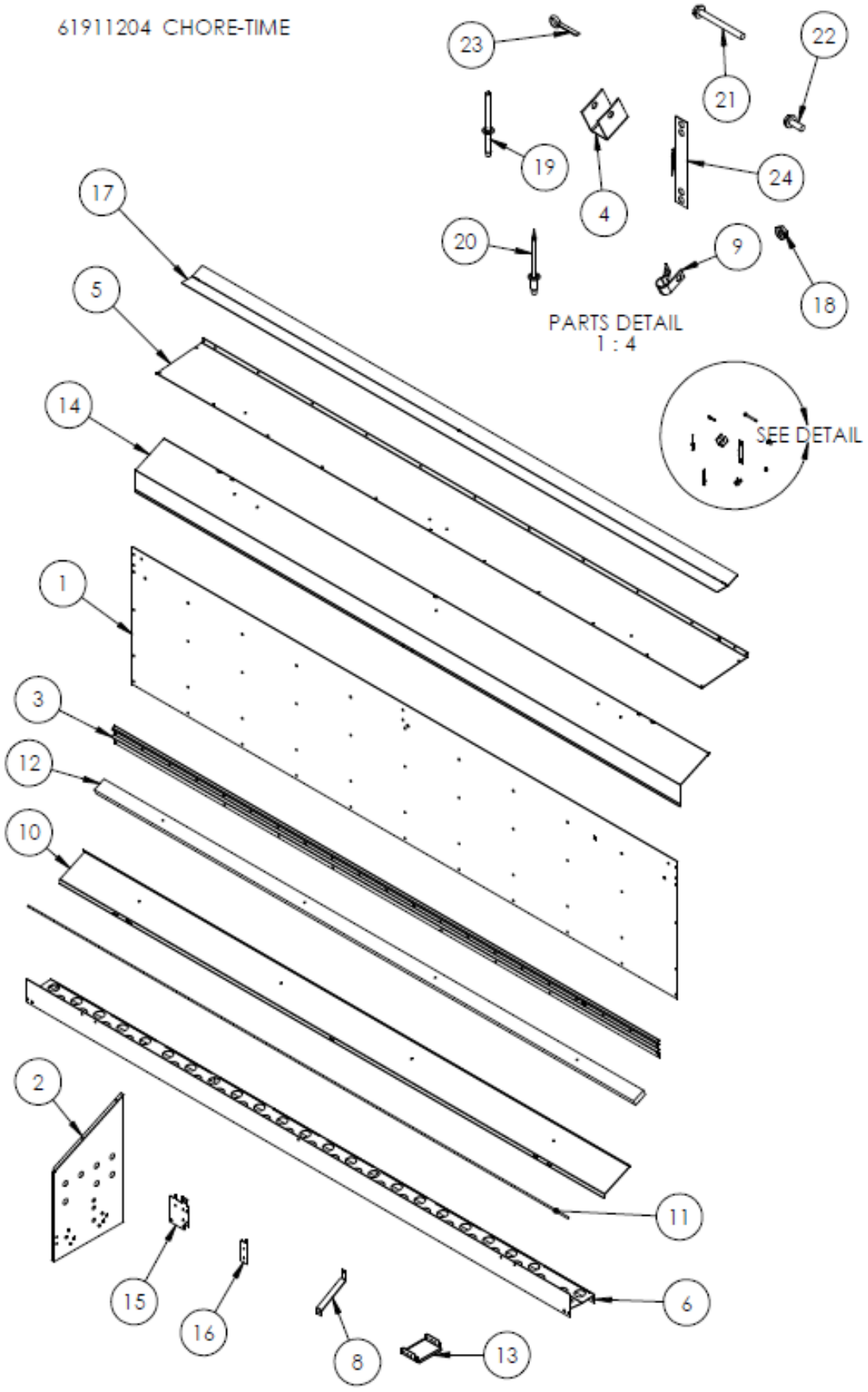

61911204 20-Hole Side Belt Nest

Item	P/N	Description
1)	16560264	C-T BACK, 20 HOLE S.B.
2)	16500166	PARTITION:NEST UNIV-RTNR HOLES
3)	16560008	STRINGER:20 HOLE NEST UNIV.
4)	16500006	BRKT: PERCH / ROD SUPPORT
5)	16500010	TOP: 9.6" HOLE UNIV. NEST
6)	16560270	TRAY ASSY, SB 20 HOLE OPEN
8)	16560004	BRACE, EGG TRAY SIDE BELT
9)	16-8904	CLAMP: HINGE SS 3/8 WIDE
10)	16500017	COVER, EGG TRAY SIDEBELT NEST
11)	16060026	WIRE:BTM SPRT GLV 0.206x95.125
12)	16-34533	PERCH: 95" - DRILLED
13)	16560017	BRACKET:EGG TRAY CHANNEL
14)	16500016	LID: SIDEBELT CLOSEOUT UNIV.
15)	16560016	BRACKET,NEST SUSP. & JOINT
16)	16-34790	BRACKET, S.BELT CENTER FLIPPER
17)	16560241	FLIPPER NEST UNIVERSAL
18)	16-90076	NUT, HEX 10-24 W/NYLON
19)	16-33139	RIVET:POP 3/16" ALUM -LONG
20)	16-34096	RIVET:POP 3/16" ALUM -SHORT
21)	16-90078	SCREW:10-24 x 2-1/4 HX
22)	16-90077	SCREW,HX HD MACH 10-24
23)	16-12500	PIN: COTTER STEEL 1/8"
24)	16560323	GUIDE, NEST BELT ENTRY

61921204 CHORE-TIME

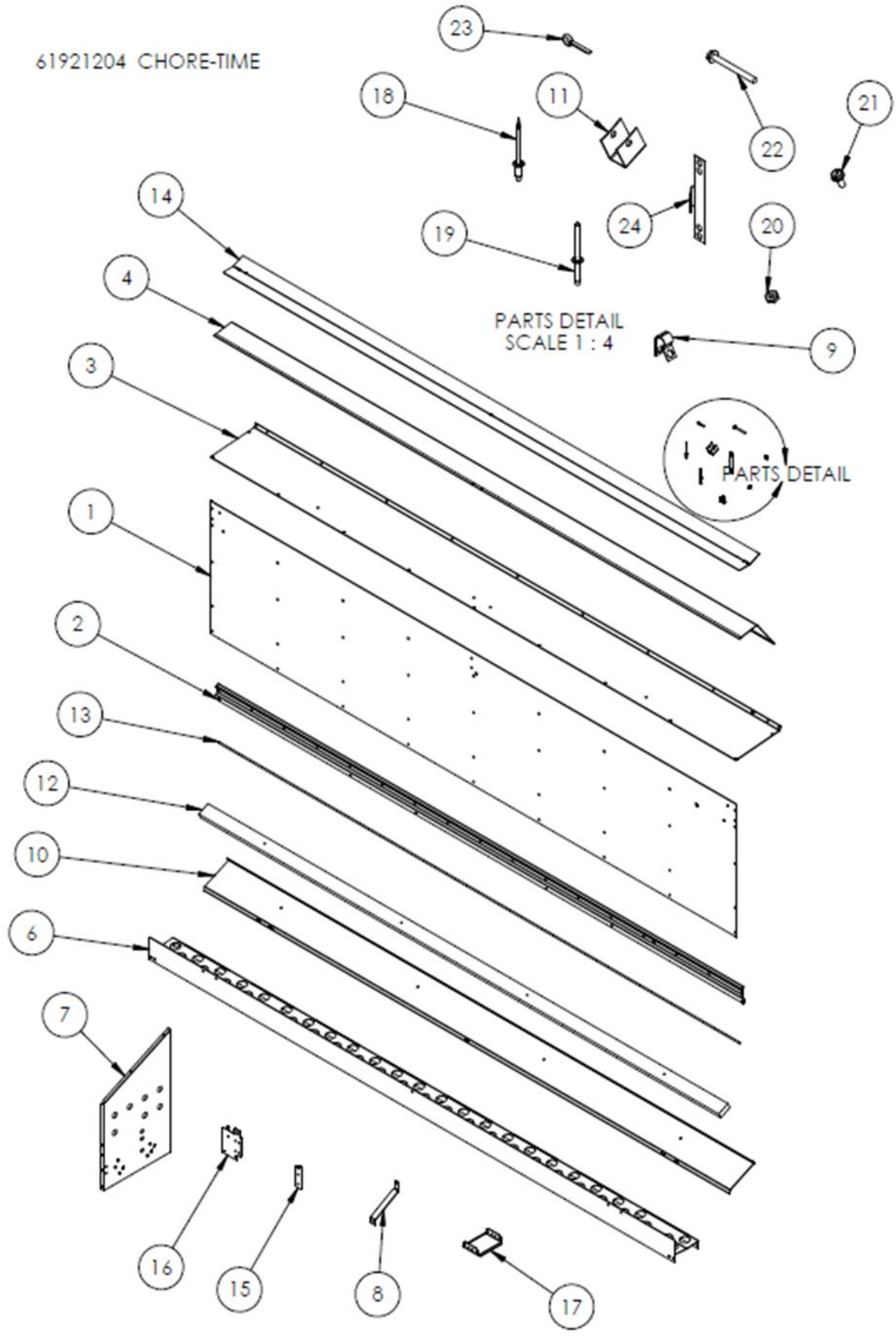

61921204 16-Hole Side Belt Nest

Item	P/N	Description
1)	16560262	C-T BACK, 16 HOLE S.B.
2)	16560007	STRINGER:16 HOLE NEST UNIV.
3)	16500009	TOP: 12" HOLE UNIV. NEST
4)	16500016	LID: SIDEBELT CLOSEOUT UNIV.
6)	16560269	TRAY ASSY, SB 16 HOLE OPEN
7)	16500166	PARTITION:NEST UNIV-RTNR HOLES
8)	16560004	BRACE, EGG TRAY SIDE BELT
9)	16-8904	CLAMP: HINGE SS 3/8 WIDE
10)	16500017	COVER, EGG TRAY SIDEBELT NEST
11)	16500006	BRKT: PERCH / ROD SUPPORT
12)	16-34533	PERCH: 95" - DRILLED
13)	16060026	WIRE:BTM SPRT GLV 0.206x95.125
14)	16560241	FLIPPER NEST UNIVERSAL
15)	16-34790	BRACKET, S.BELT CENTER FLIPPER
16)	16560016	BRACKET,NEST SUSP. & JOINT
17)	16560017	BRACKET:EGG TRAY CHANNEL
18)	16-34096	RIVET:POP 3/16" ALUM -SHORT
19)	16-33139	RIVET:POP 3/16" ALUM -LONG
20)	16-90076	NUT, HEX 10-24 W/NYLON
21)	16-90077	SCREW,HX HD MACH 10-24
22)	16-90078	SCREW:10-24 x 2-1/4 HX
23)	16-12500	PIN: COTTER STEEL 1/8"
24)	16560323	GUIDE, NEST BELT ENTRY

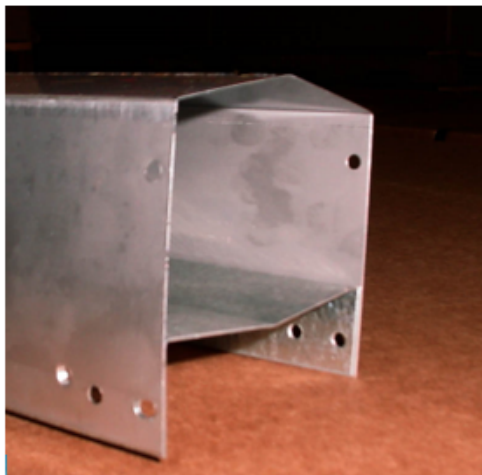

- 16560041 P-WAY 18" w/CONNECTOR
- 16560042 P-WAY 24" w/CONNECTOR
- 16560043 P-WAY 28-3/4" w/CONNECTOR
- 16560044 P-WAY 36" w/CONNECTOR
- 16560045 P-WAY 48" w/CONNECTOR
- 16560046 P-WAY 72" w/CONNECTOR
- 16560047 P-WAY 96" w/CONNECTOR

## FINGER PADS AND NEST BOTTOMS

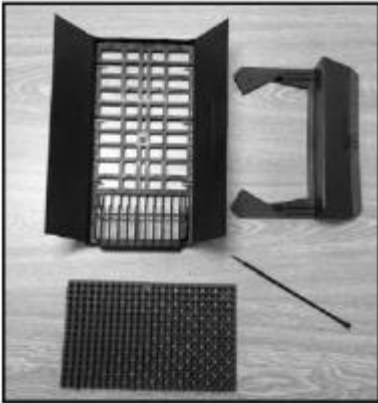

**61512201** for 9.6" holes  
KIT, 20 HOLE: BROWN DINGER PAD  
PLAST BTM w/GRILL, FRONT, TIE

16060024: Bottom, PL Nest Narr Open Base  
16-13185720: 5.63x9.63 BROWN Finger Pad  
16-37199 Tie: Cable Outdoor 7-1/2"  
16-37362: Front

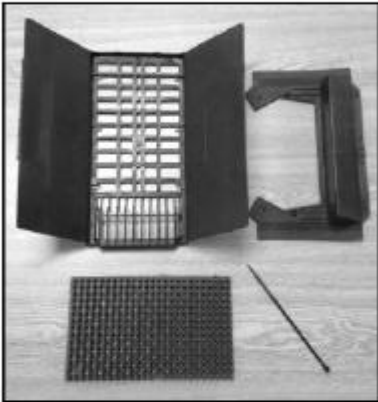

**61522201** for 12" holes  
KIT, 16 HOLE: PLASTIC BTM. w/GRILL, FINGER PAD,  
FRONT

16060023: Bottom, PL Nest Wide Open Base  
16-13185720: 5.63x9.63 BROWN Finger Pad  
16-37360: Front  
16-37199: Tie: Cable Outdoor 7-1/2"



**61512501** for 9.6" holes  
KIT, 20 HOLE, OPEN NXT TURF PAD

16060087: Pad: TURF GREY NXT 5.63x9.63  
16060024: Bottom, PL Nest Narr Open  
16-37362: Front: Nest-Segd -Narr  
16-37199: Tie: Cable Outdoor 7-1/2"

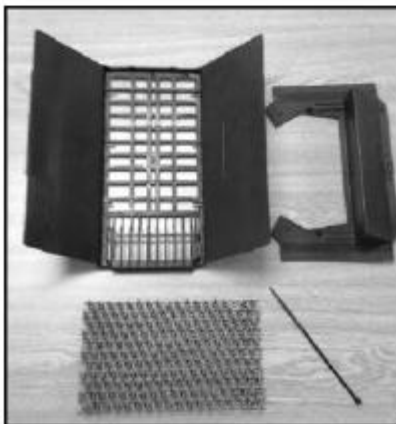

**61522501** for 12" holes  
KIT, 16 HOLE, OPEN NXT TURF PAD

16060087: Pad: TURF GREY NXT 5.63x9.63  
16060023: Bottom, PL Nest Wide Open  
16-37360: Front: Nest-Segs-Wide  
16-37199: Tie: Cable Outdoor 7-1/2"



## 16560260 -SB NEST LID CLOSER SYSTEM KIT

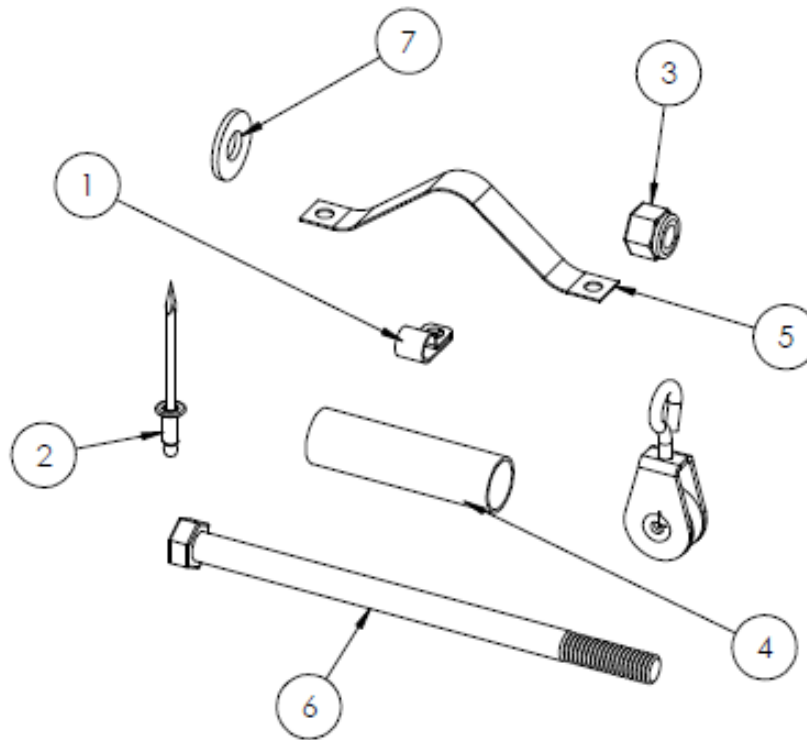

ITEM NO.	PART NUMBER	DESCRIPTION	QTY.PER
1	11000034	CLAMP WIRE NYLON Ø.375 WIRE	2
2	16-34096	RIVET:POP 3/16" ALUM -SHORT-	14
3	16005182	NUT 3/8-16 NYLON LOCK	1
4	16060113	SPACER EMC 1/2 GALV X2.5	2
5	16-103329	SPRING, SB LID CLOSER	6
6	16060112	BOLT, HEX HEAD 3/8-16X6	1
7	16-63708	WASHER,FLAT.375ID x.75OD x.10T	2
8	00102335	SMALL METAL PULLEY	2



Left) 40787 - BOLT,SPLIT .500-13UNCX.815  
 Right) 40788 - CAP,SPLIT BOLT

## **PART III**

# **INSTALLATION INSTRUCTIONS**

## HAND WINCH

### GENERAL SAFETY RULES

Hand winch for nesting lines for poultry



**DANGER**

### **IMPORTANT**

Carefully read the following instructions before you **INSTALL** the system

- 1. PAY ATTENTION** when **WINCHING UP** or **WINCHING DOWN** the nests:
    - **STOP** the handling in case of any malfunctioning.
    - **NEVER** stand **UNDERNEATH** the load when winching up or putting down the nests.
  - 2. NEVER ALLOW UNAUTHORIZED PERSONS ENTER** the house during your absence.
  - 3. ALWAYS** choose a location which stands the maximum lifting capacity of the hand winch.
  - 4.** Only use the hand winch for suspension of a **CHORE-TIME heating line**.
  - 5.** Put the hand winch
    - In a location where there's **less passage**.
    - So that the user **doesn't stand underneath the load** while handling.
    - At a **well-lit, dry, roofed and good accessible place**.
    - On a **solid wall**.
    - So that the handle can be easily used.
    - So that the **warning marking is ALWAYS visible**.
  - 6.** Only use the **supplied mounting kit** for fixing the wall.
  - 7. ALWAYS** check the condition of the hand winch and the cable before operating. A **raveled, kinked or damaged cable** must be replaced **IMMEDIATELY**. A loose or damaged hand winch must be replaced **IMMEDIATELY**.
- Don't use water** to clean the hand winch.



**FORBIDDEN: NEVER** use the hand winch to lift persons.



**DANGER:** Getting jammed by the handle may cause **SERIOUS INJURIES**.

## HAND WINCHING TROUBLE SHOOTING GUIDE



**Not respecting above-mentioned instructions can cause physical injury or material damage.  
Use personal protective equipment.**

**ACTIONS IN GREY BACKGROUND MUST BE DONE BY A TECHNICALLY TRAINED PERSON.**



**SEE TO IT THAT YOU FIRST REMOVE EACH ELEMENT WINCH CAN OBSTRUCT A SAFE OPERATION OF THE SYSTEM!**

PROBLEM	CAUSE	CORRECTIVE ACTION
1. Brake doesn't work	a. Screw thread on the drive shaft or the handle is damaged.	-Replace the hand winch.
	b. Screw thread on the drive shaft or the handle is dirty.	-Clean the hand winch dry.
		-When not OK, please ask a technically trained person.
	c. Brake discs are dirty.	-Clean the hand winch dry.
-When not OK, please ask a technically trained person.		
2. Winching doesn't work	a. Load is too heavy.	-limit the load till max 300 kg.
	b. Cable to the load is blocked somewhere.	-Release the cable.
	c. Drum weldment or drive shaft of the hand winch is blocked because of dirt or rust.	-Clean the hand winch and grease when necessary.
		-Clean the hand winch and grease when necessary.
3. Putting down the load doesn't work.	a. Safety lock is switched on.	-Take the handle and unlock the safety lock.
	b. Cable to load is blocked somewhere.	-Release the cable
	c. Drum weldment or drive shaft of the hand winch is blocked because of dirt or rust.	-Clean the hand winch and grease when necessary.

### MAINTENANCE INSTRUCTIONS



**Use personal protective equipment**

- Remove all dirt and dust after each batch or at least every 6 months.
- See to it that the handle turns fluently on the crew thread of the main shaft.
- Don't use water to clean the hand winch.
- Use grease to grease moving parts.

**Step 1.** Attach Partitions to the **Back** as shown. The rivet should capture both partition flanges and the back. Orientation of the "N" or "W" I.D. stamping on the **Back** is not critical

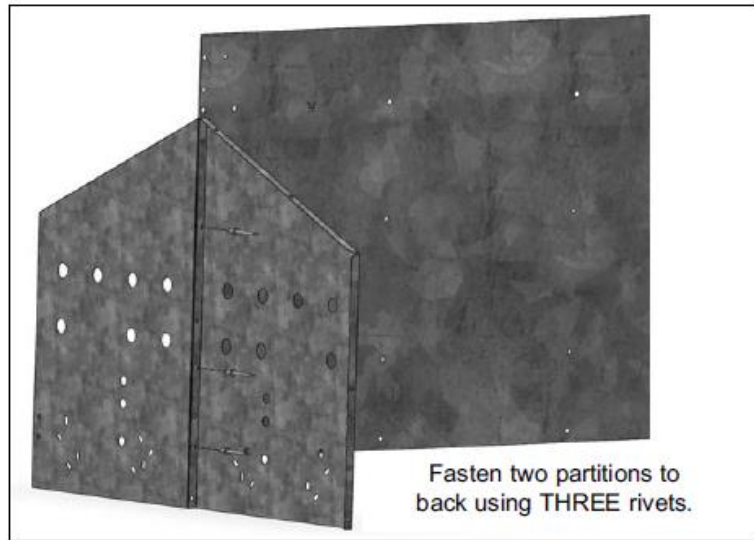
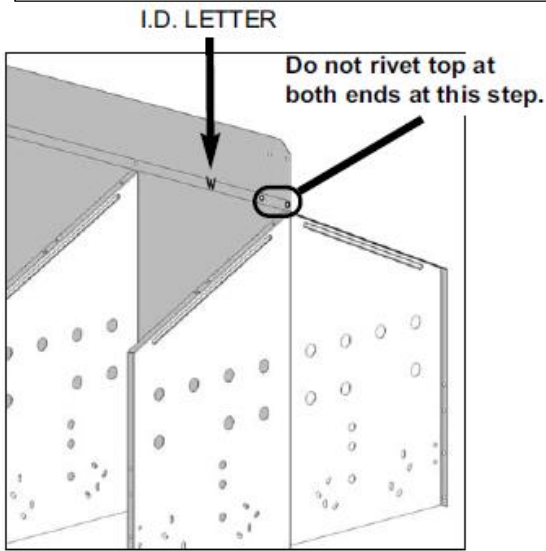

**Step 2.** Attach egg trays to partitions.

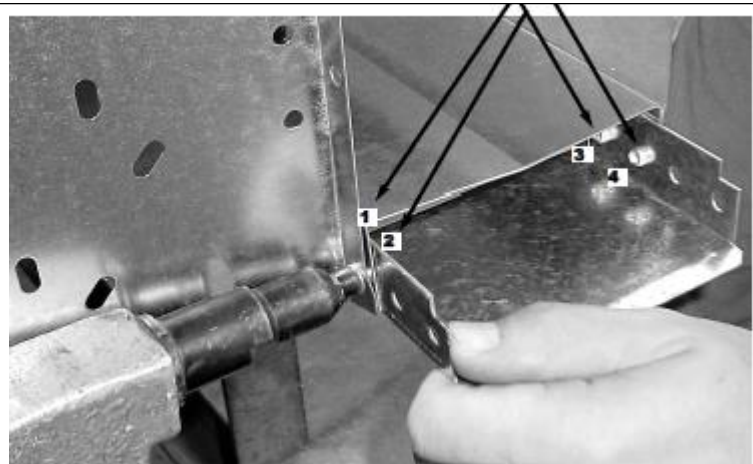
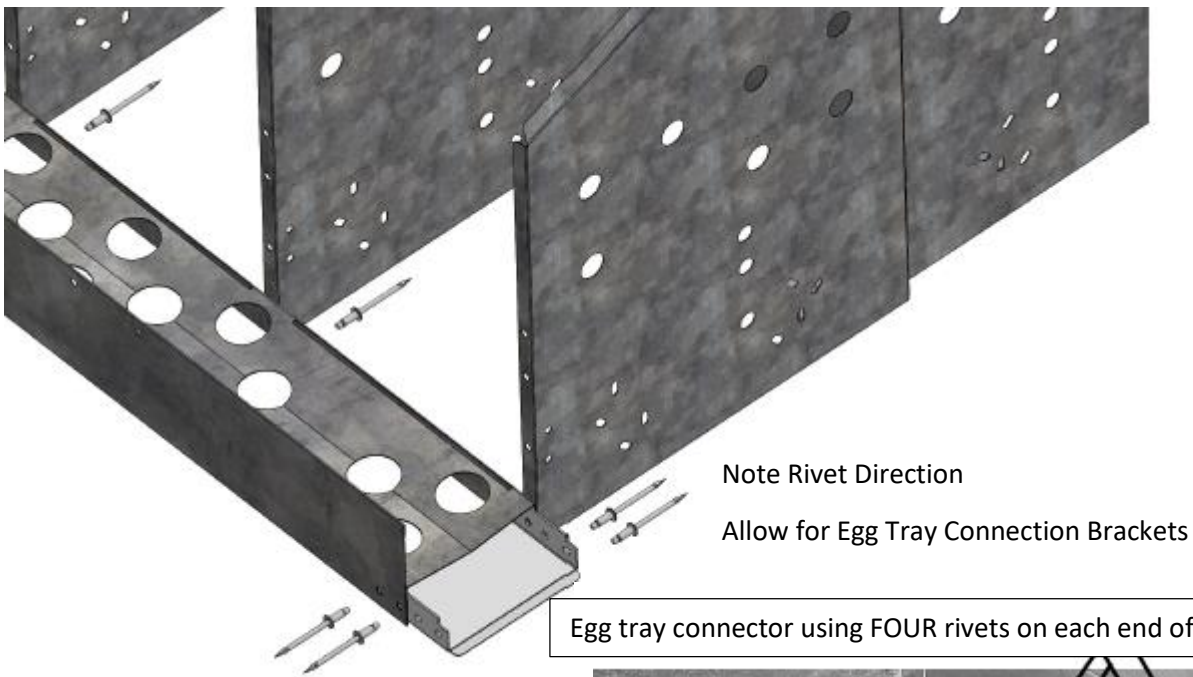

**Step 3.** For nests using plastic fronts, attach fronts to stringer as shown. Insert Rivet through plastic front into Stringer.

Rivet through plastic into stringer.

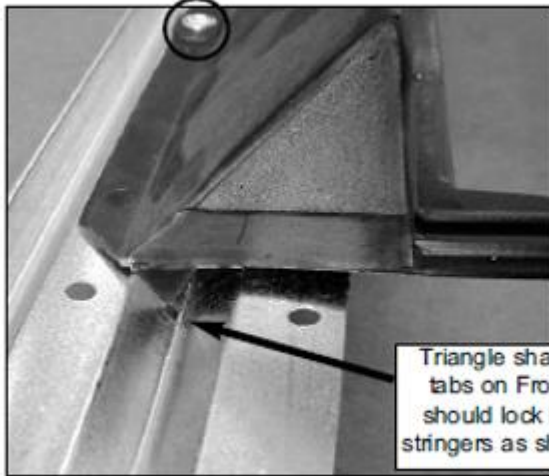
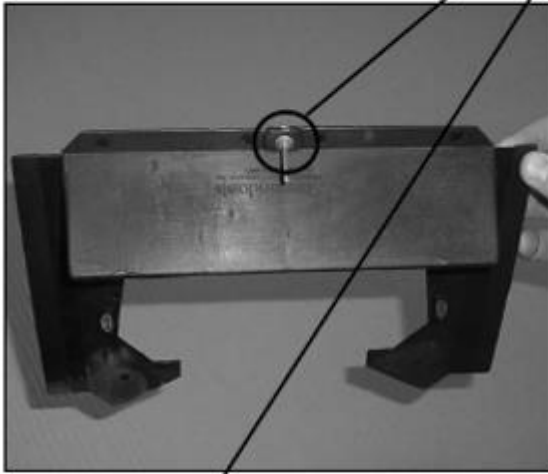

**⚠ ATTENTION**  
**USE LONG RIVETS FOR:**  
**Plastic Nest Front Attachment**

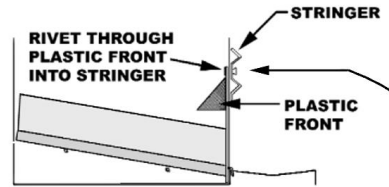

**Pop-Rivet Detail**

16-33139

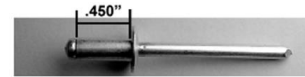

Enclosed in bag, use HERE

SHOWN FOR REFERENCE

16-34096

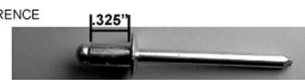

Shipped in bulk with nest parts.



**Step 4.** Attach Front/Stringer Assembly as shown. Attach **Egg Tray Braces** (narrow end) between the **Stringer** and the **Partitions** at the following positions:

- a. 20 Hole Nest: Partitions #2, #6 and #10.
- b. 16-Hole Nest: Partitions #2, #5 and #8.

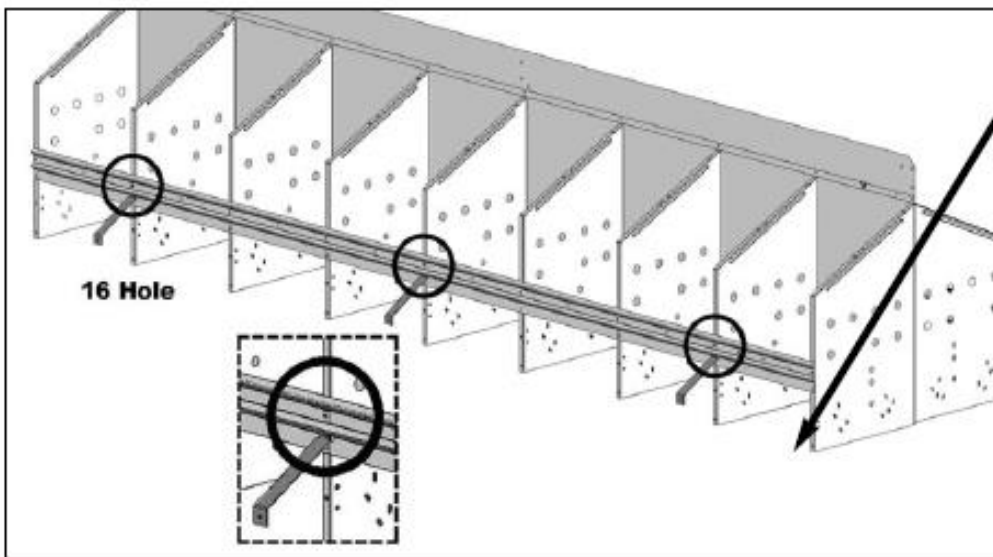
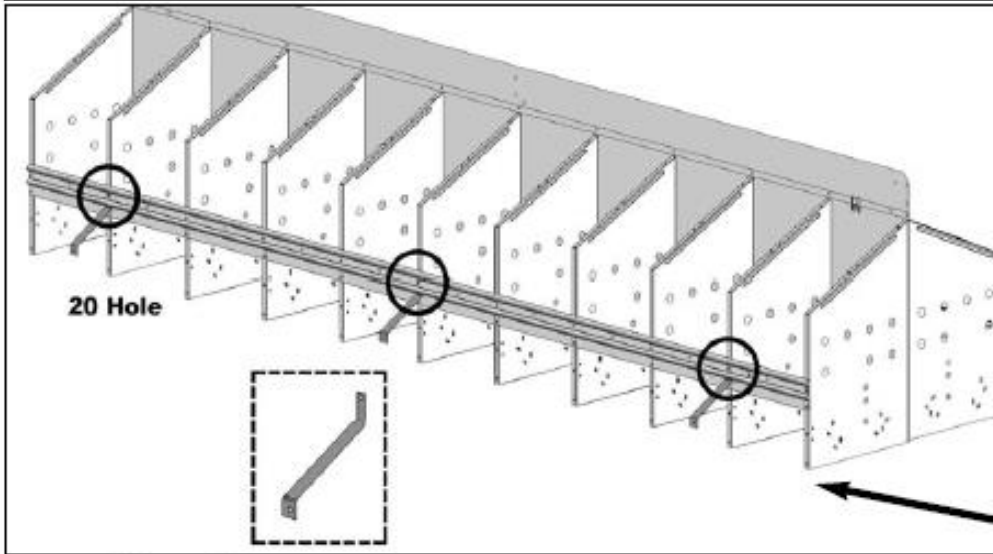

**NOTE:**

Egg Tray Assemblies and Fronts are not shown in the illustrations for clarity of instruction.



**Step 5.** Attach The **Egg Tray Covers** as follows:

- a. Compress **Hinge Clamp** with pliers or guide nail and align with middle **Egg Tray Brace**. Fasten with Long rivet from RIVET PACK through **Hinge, Egg Tray** and **Tray Brace**.
- b. Insert **Hinge Clamp** into middle slot on **Tray Cover** flange.
- c. Repeat for **Cover/Hinge/Egg Tray/Bracket** connection on each end of cover.

Covers should 'latch' closed beneath **Stringer** when hinges are installed properly. Open covers again for Step 6.

**⚠ ATTENTION**  
**USE LONG RIVETS FOR:**  
Hinge attachment

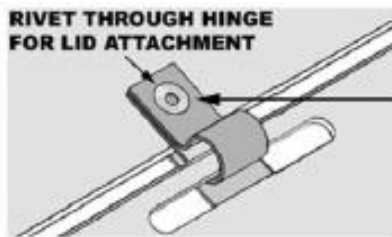

**Pop-Rivet Detail**

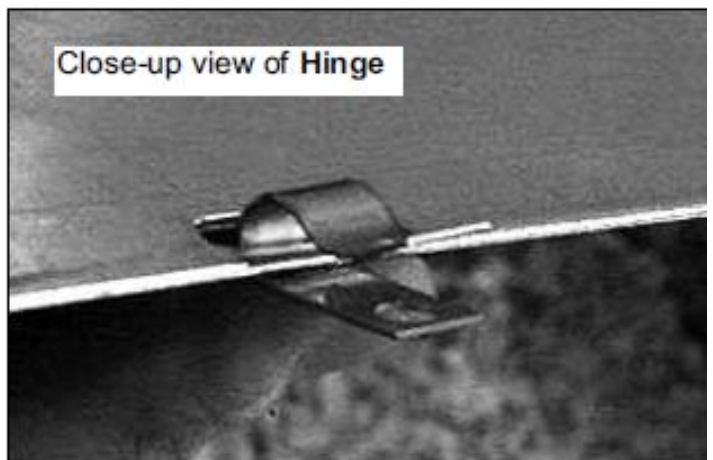
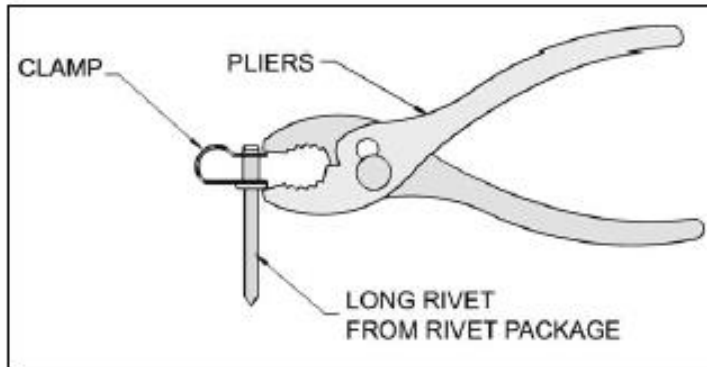

View of rivet through Hinge, Egg Tray and Bracket.

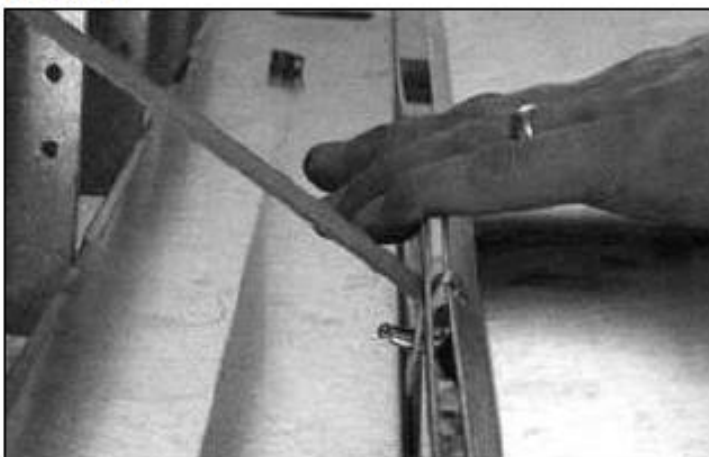

Close-up view of Rivet installed





**Step 6.** Install **Perch Brackets** and wooden **Perch** to **Egg Tray Covers** as shown. The shallow “V” in the ends of the bracket legs should install toward wooden **Perch**.

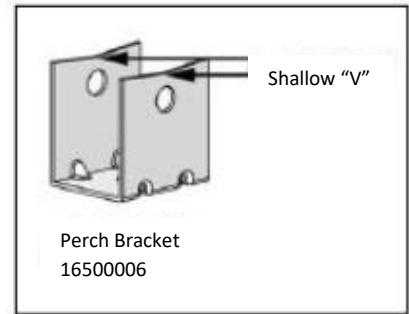
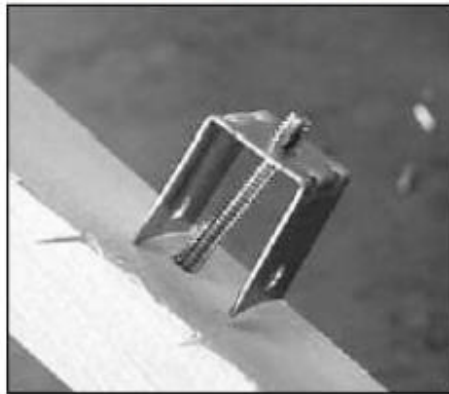
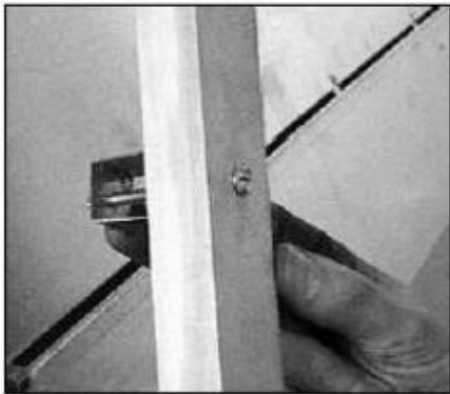

View of Bracket installed beneath perch



**Caution:** Do Not lift, carry, or move assembled nest bodies with the wooden perch rails. The weight of the Nest Body will bend and damage the Tray Cover Hinges, preventing them from closing properly.

**Step 7-A.** Side **Support Rods** through the appropriate position slots in the end partition.  
See Diagram Below.

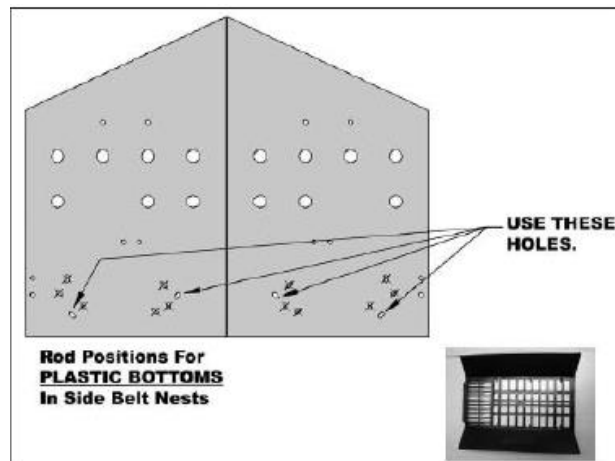

**Step 7-B.** Install **Support Rod/Perch Brackets** with rivets on **End Partitions** only.



Support Rod installation and Rod Support Bracket locations.  
**INNER PARTITIONS NOT SHOWN FOR CLARITY**

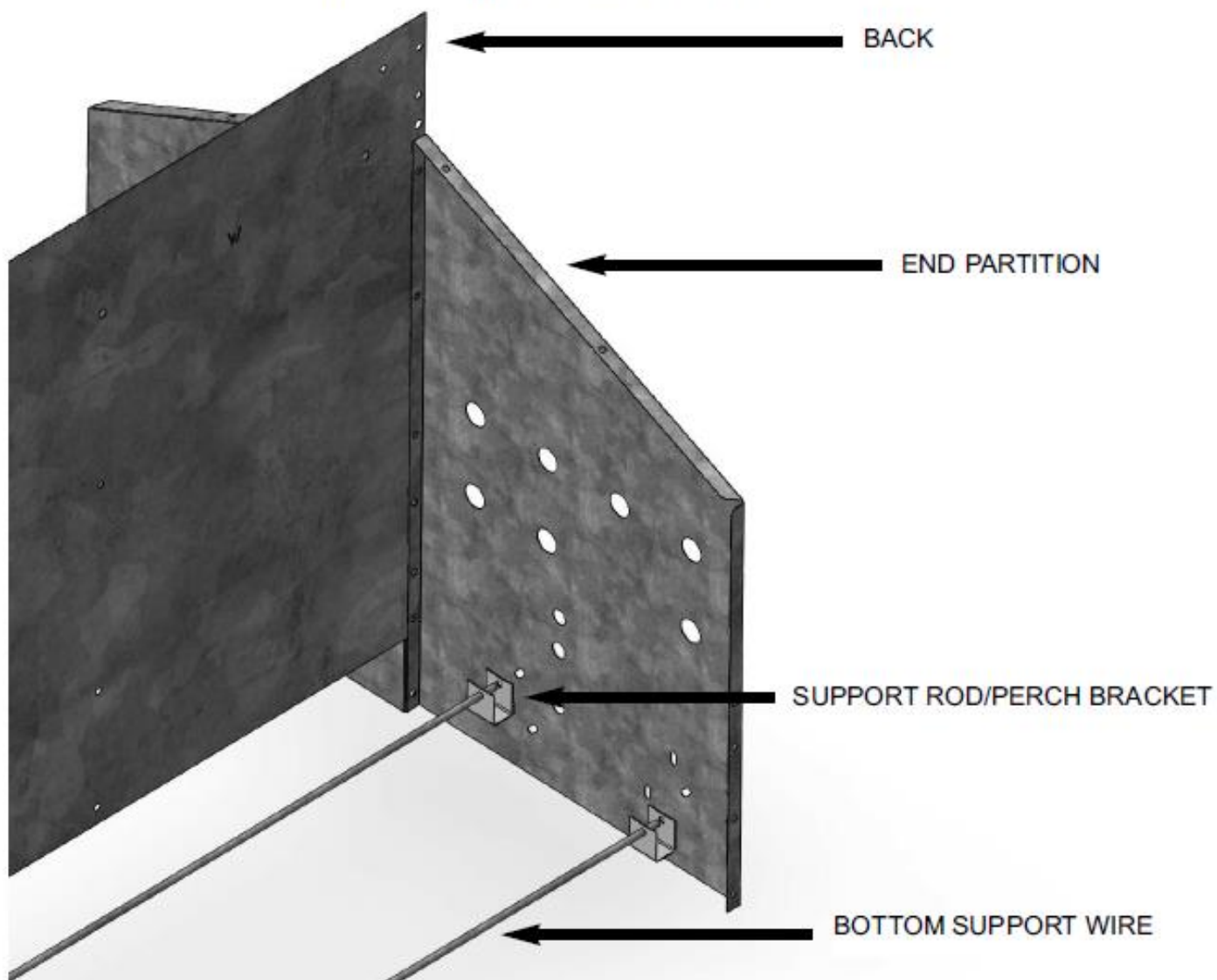

## ASSEMBLY OF NEST PAD TO NEST BOTTOM

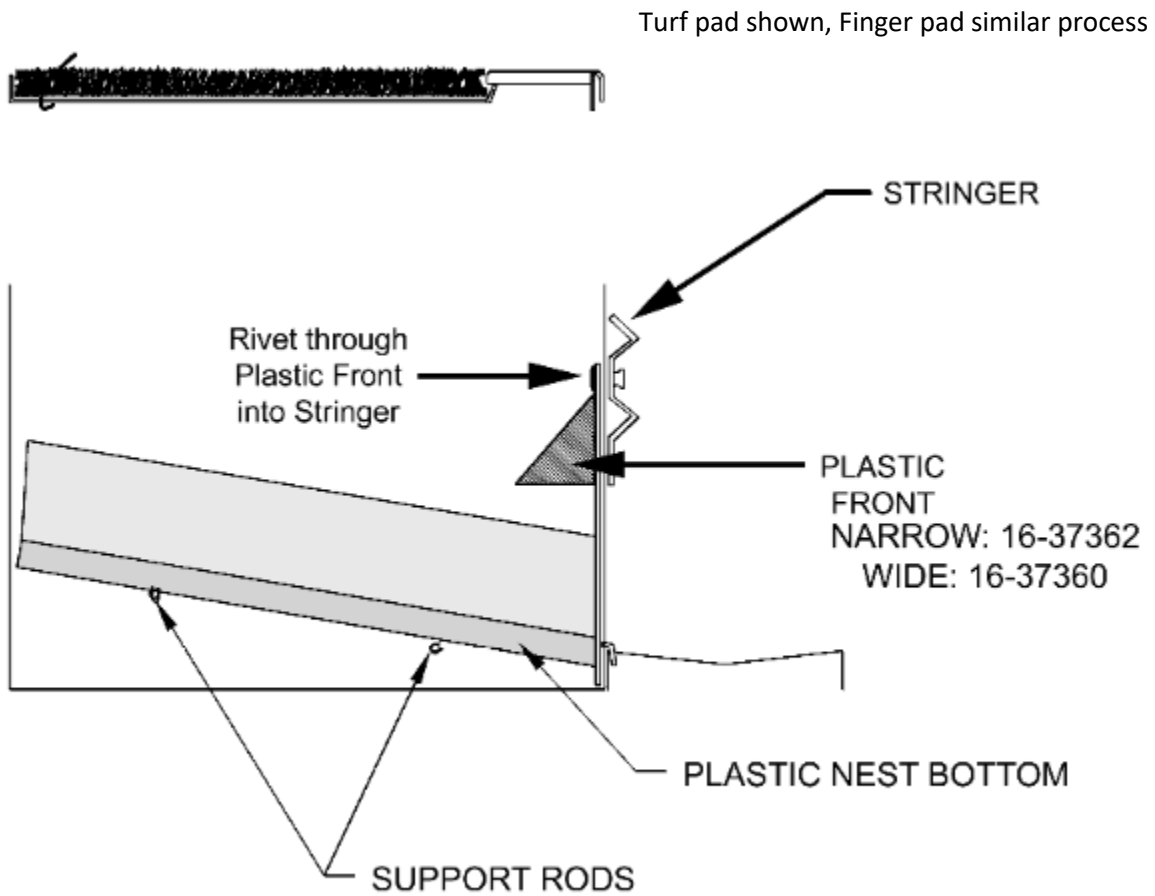
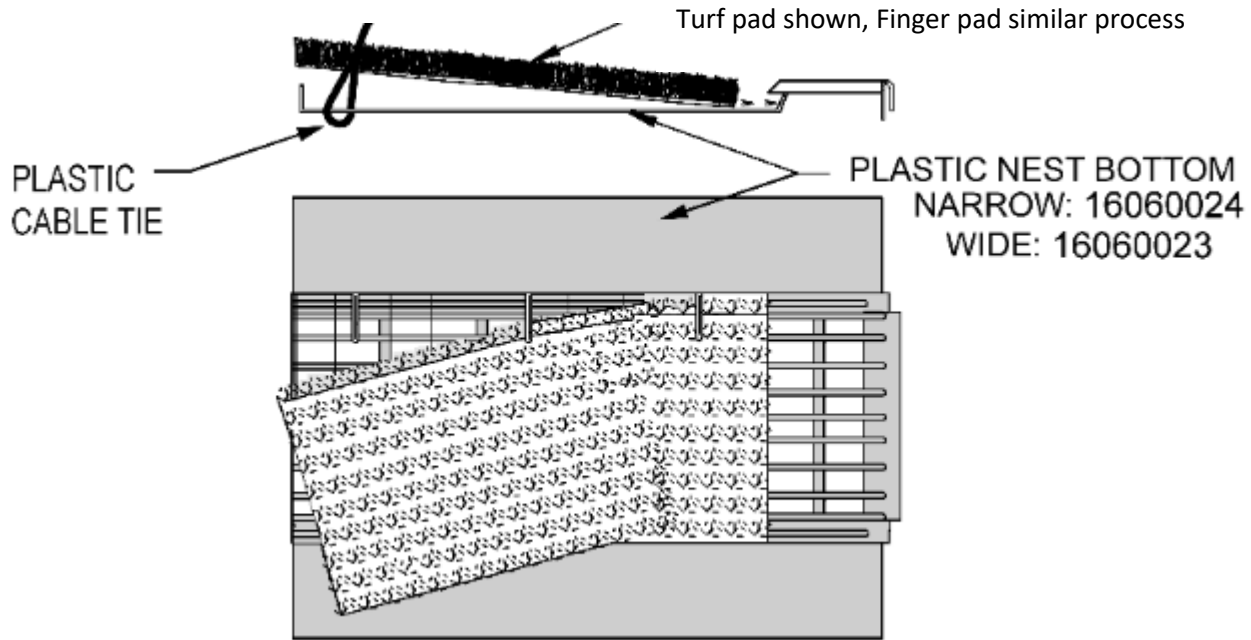

1. Insert nest pad under three support fingers on right side.
2. Insert nest pad under three support fingers on left side.
3. Be sure nest pad lays flat in bottom.

**Step 8.** Attach **Tops** as shown. **Do not** apply rivets in the following positions at the time.

- a. First and last holes (both ends of Top) on flange to Back.
- b. 20-Hole Nest: Partition #2, #6, and #10 (both sides)
- c. 16-Hole Nest: Partition #2, #5 and #8 (both sides)

The nest lid **Hinge Clamps** will attach here and are installed later.

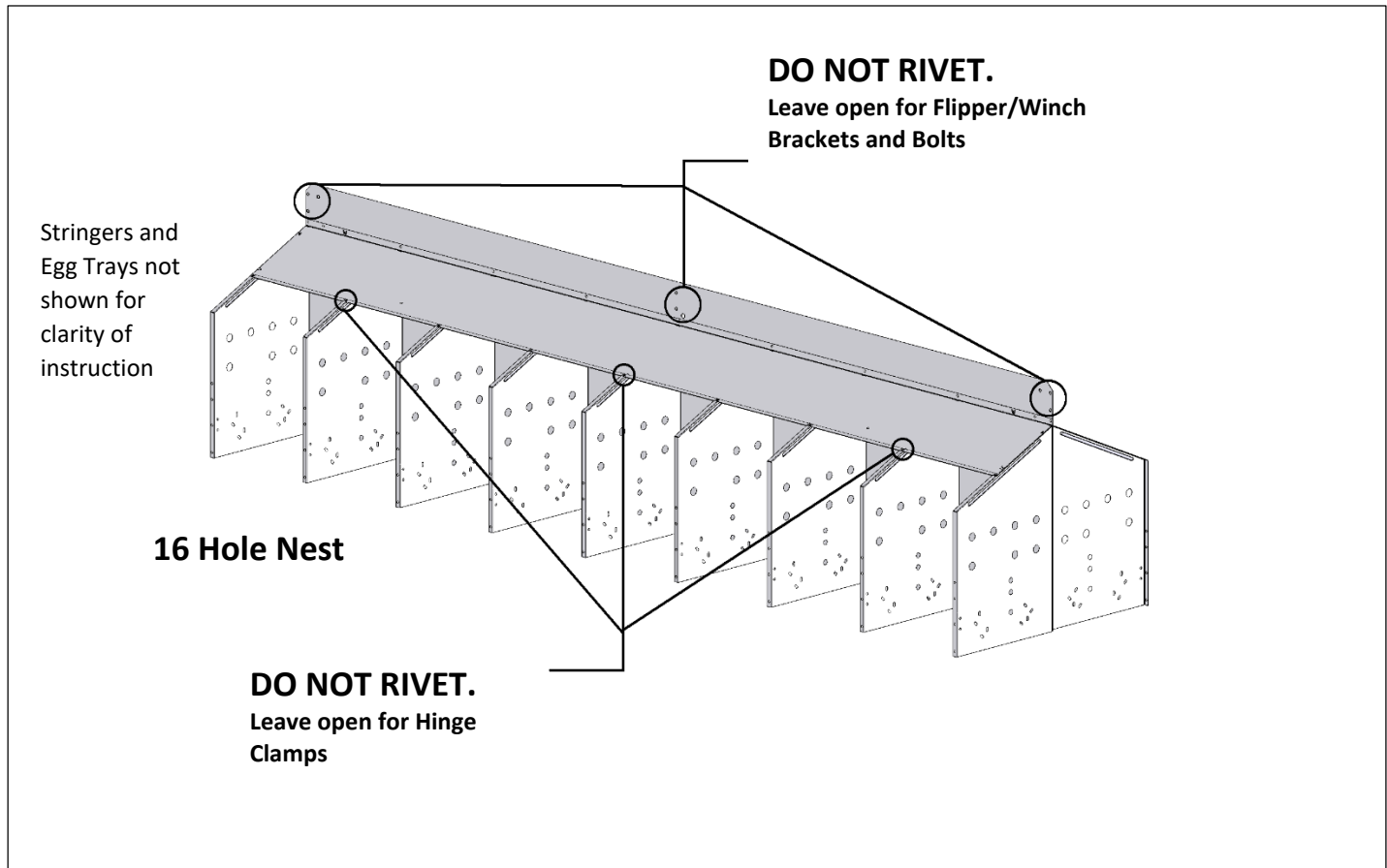
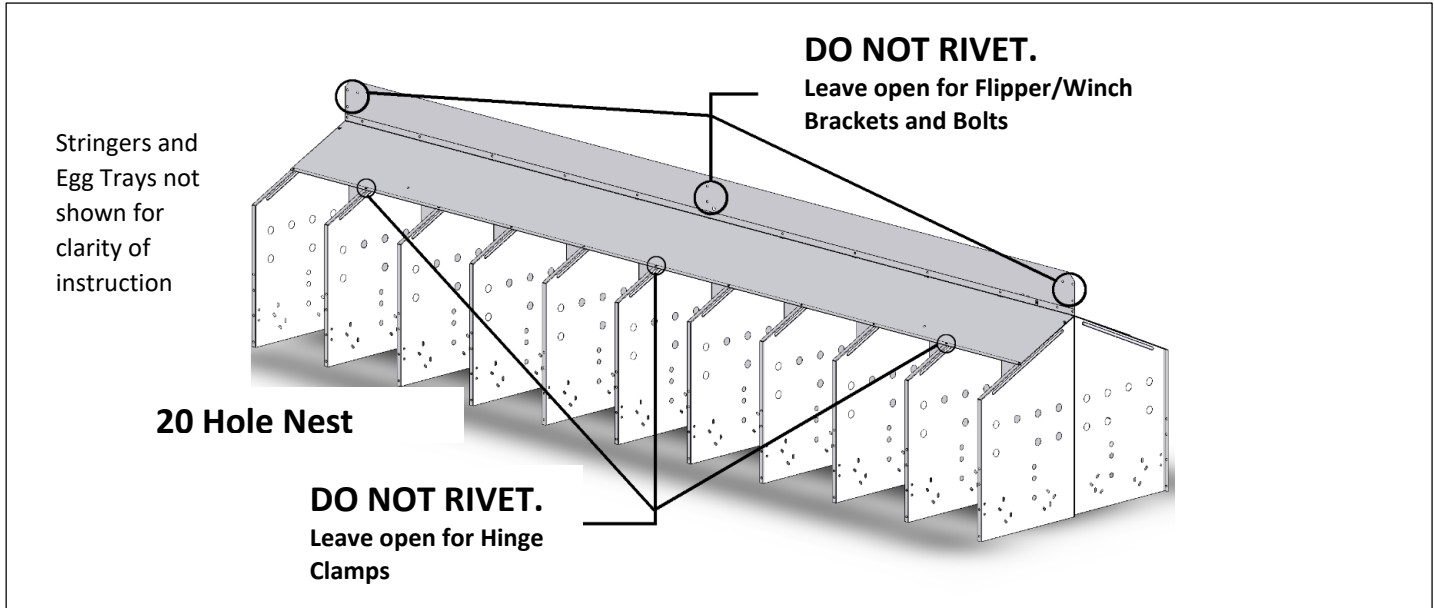

**Step 9.** Attach the **Nest Lid** as follows:

- a. Compress **Hinge Clamp** with pliers or guide nail and align with middle hole on **Top** and **Partition**. Fasten with Long rivet from RIVET PACK through **Hinge** and **Top** into **Partition**.
- b. Insert **Hinge Clamp** into middle slot on **Nest Lid**.
- c. Repeat for **Lid/Hinge/Partition** connection on each end of **Lid**.

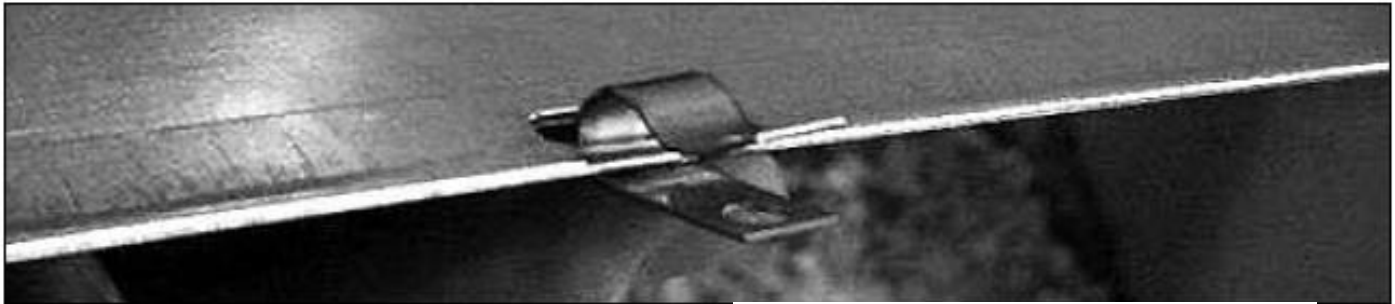

**ATTENTION**  
**USE LONG RIVETS FOR:**  
**Hinge Attachment**

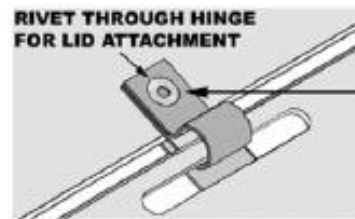

**Pop-Rivet Detail**

16-33139

.450"

Enclosed in  
bag,  
use HERE

SHOWN FOR REFERENCE

16-34096

1.325"

Shipped in bulk  
with nest parts.

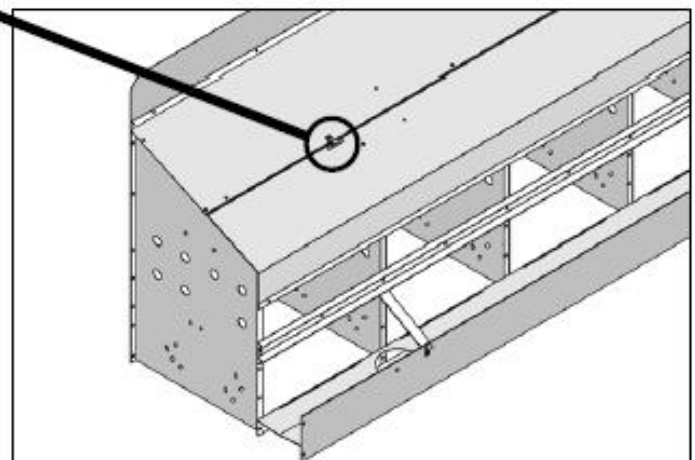
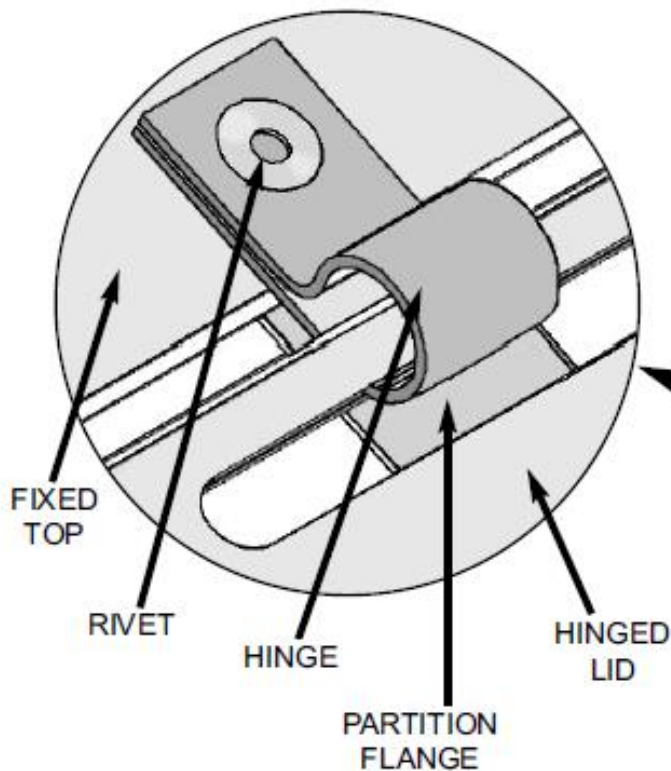

**Step 10. Install Suspension Brackets**



**DO NOT USE  
RIVETS TO SECURE  
SUSPENSION  
BRACKETS TO NEST**

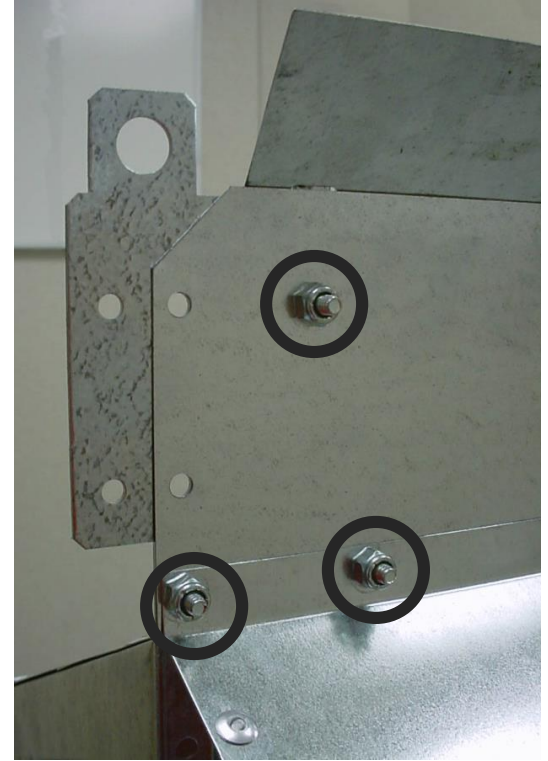

**Install Winch Brackets on top corners of back with the #10-24 hardware supplied.  
DO NOT USE RIVETS.**



Install **Universal Flipper Bracket** using #10-24 hardware as shown. Align holes on **Flipper** with **Universal Bracket** to determine correct Bracket mounting.

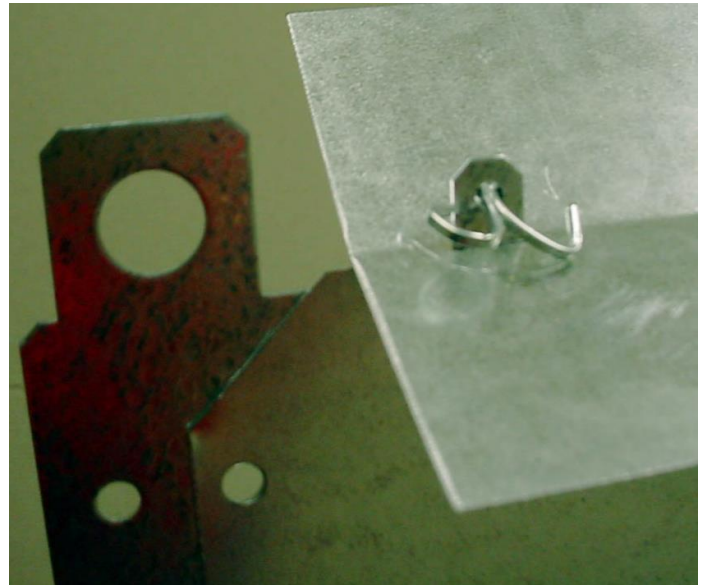

Install **Flipper** over stem on **Winch** and **Universal Center Brackets** and insert **Cotter Pins** through bracket stem holes. Secure by curling pin ends.

**Step 11. CONNECTING NESTS TOGETHER AND TO WINCHING SYSTEMS**

Select winches that will safely support the system. An 8' section weighs approximately 120-130 pounds.

**WE, THE MANUFACTURER, CANNOT BE RESPONSIBLE FOR THE CAPABILITIES OF THE STRUCTURE TO SUPPORT THIS SYSTEM. FOR WEIGHT LOAD CAPABILITIES, CONTACT YOUR BUILDING CONTRACTOR.**

A cable drop is required at the end of each 8' nest section. Cable saddles, cable clamps or "S" hooks may be used to attach to the nest brackets.



↑  
Egg Tray Connection Brackets Require **EIGHT** rivets in total: **FOUR** outside of egg tray as shown and **FOUR** inside of egg tray (see step 2).

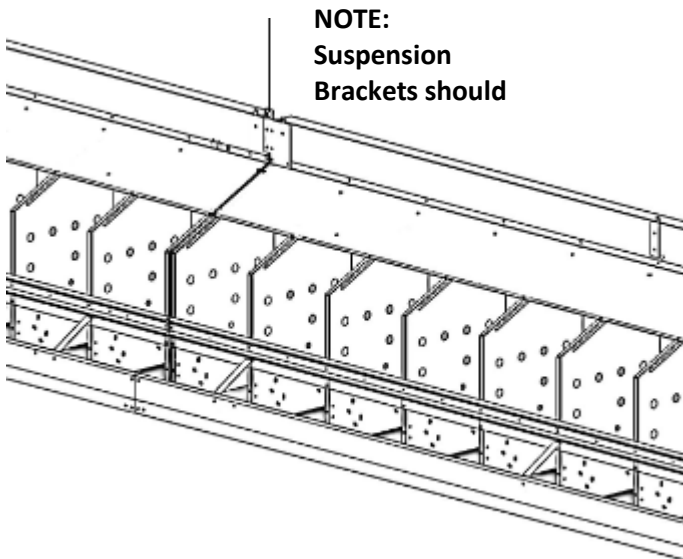

**Level the system from side to side as well as along the length of the line.**

When placing the nest system on slats, whether on wooden or plastic, Manufacturer *recommends* that the nest line be leveled by placing 1' x 4' wooden strips over the slats and underneath as shims. This aligns the belt support trays with the egg belt and prevents the conveyor belt from rising up off the support trays, allowing eggs to roll beneath and be trapped under the egg belt.

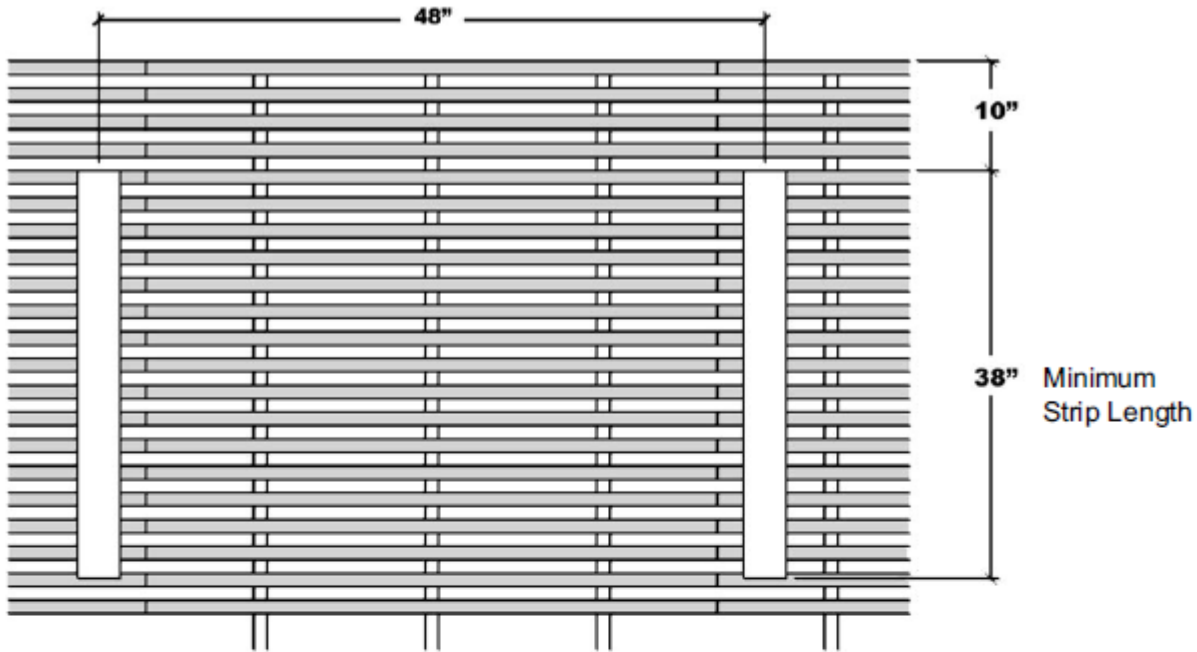

**8' SECTION PLACEMENT OF 1 x 4 x 38 STRIPS**

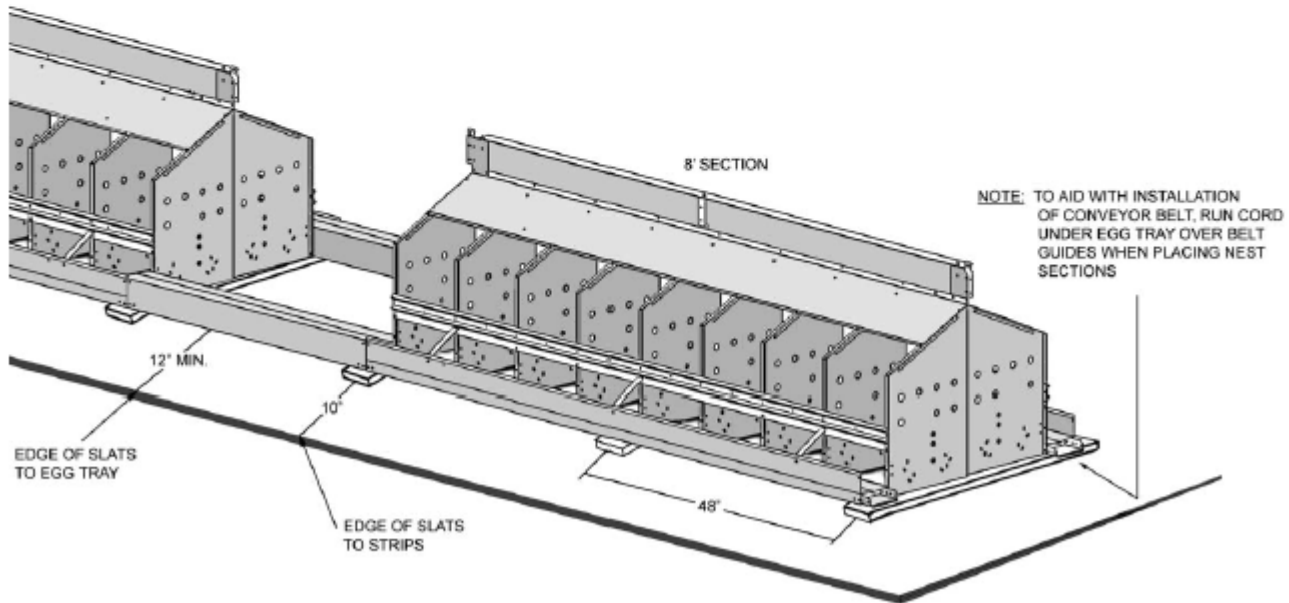

**PLACEMENT OF NEST ON STRIPS**



## Step 12. PASSAGEWAY INSTALLATION INSTRUCTIONS

It is essential the sections be properly aligned and leveled to allow free movement of the conveyor belt.

The double nest sections are to be connected together, or to the conveyor passage, by the connector brackets on the conveyor trays and suspension bracket at the top.

View from front of nest.

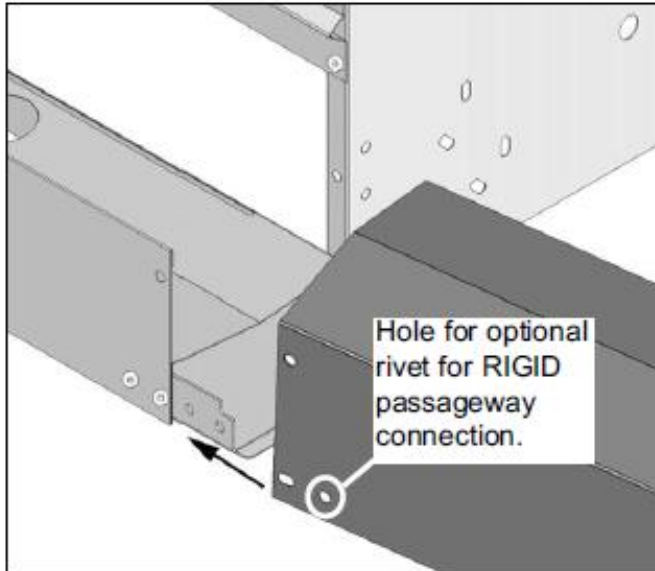

View from back of nest.

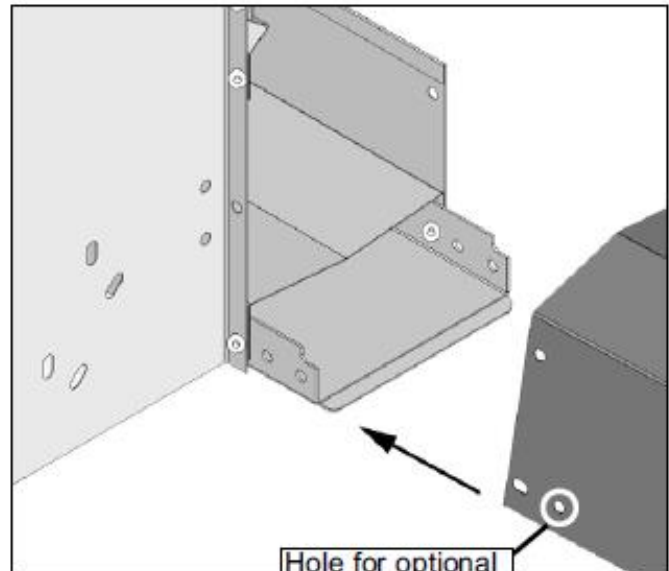

Attach passageway to nest brackets using rivets. Rivet in all holes (4x) are OPTIONAL for added strength and line rigidity. Rivets in holes nearest nest body only (2x) allow for flex between uneven suspension points or winching systems along line length. See picture below.

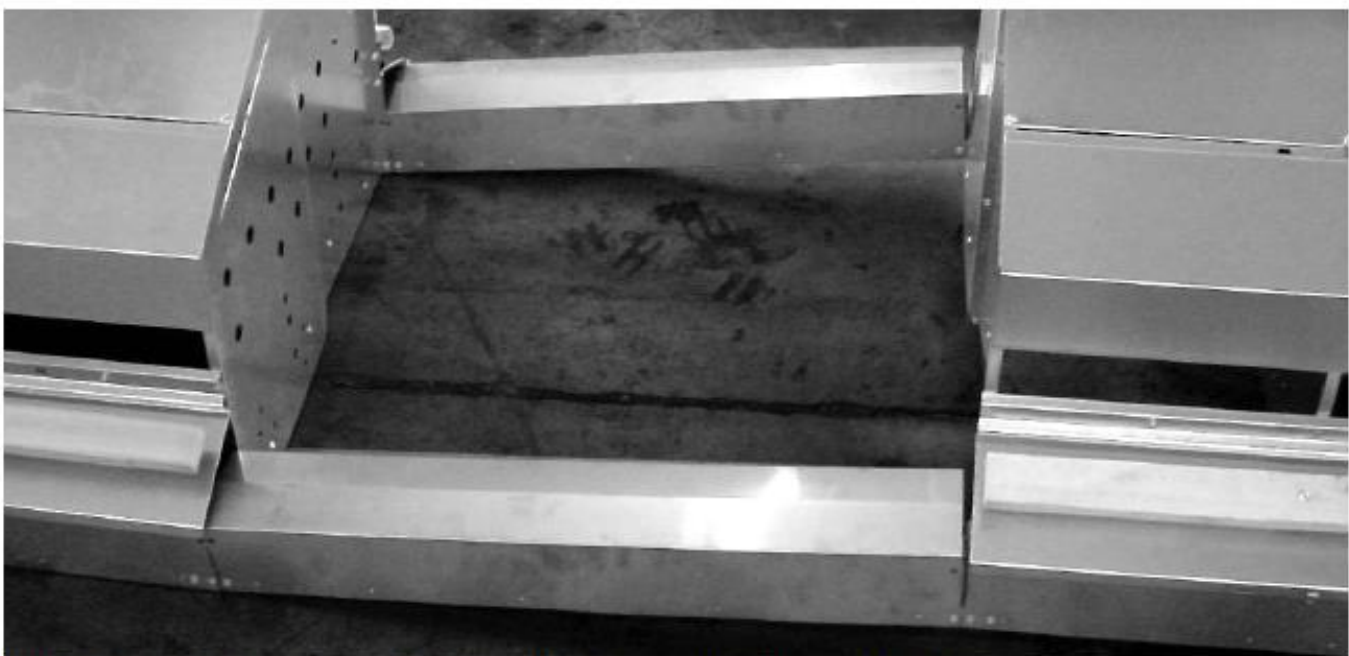

Illustration of a 2 Rivet connection per end of passageway to permit line flex.

**ATTENTION:**  
**Nest Line Alignment Notice**

**Nest Lines MUST be aligned and straightened after installation and before egg collection begins at the start of each flock. Once the nests are resting on the slats, the nest egg trays must be straightened with each other horizontally from side to side, and vertically. Shims may be required to lift the nests from underneath off the slats for vertical leveling the egg trays.**

**Failure to complete this alignment of the nest line WILL result in premature egg belt wear, belt edge fraying, eggs under belts, and possible belt breakage. In addition, badly frayed and worn belts can cause damage to the egg belt drive system and control.**

**Also, the nests must be adjusted to be level from side to side to insure the correct bottom and pad angle for proper egg roll-out from the nest pads to the egg belt and trays. Nests that are not level from side to side may have eggs remaining in the nest hole on one side of the line, while the other side will be too steep and may cause egg shell checks and cracks. Again, shims may be required to lift the nests from underneath off the slats for vertical leveling the nest bodies.**

**A** - Dimensions from nest to outer wall or slat system wall. Dimension "A" assumes wall on stem wall is straight. Buildings may vary. Adjust nest line side to side to make "A" dimension equal on all nests in the line.

**B** - Vertical adjustment. Shim nest lines on slats in "B" direction (up or down) as required to make egg tray surfaces between nest bodies and nest bodies and passageways flush at connection joints.

**C** - Line leveling. Egg trays should be level from side to side to insure correct floor angle in nest bodies.

**Note:** A laser level can be used for A, B, and C.

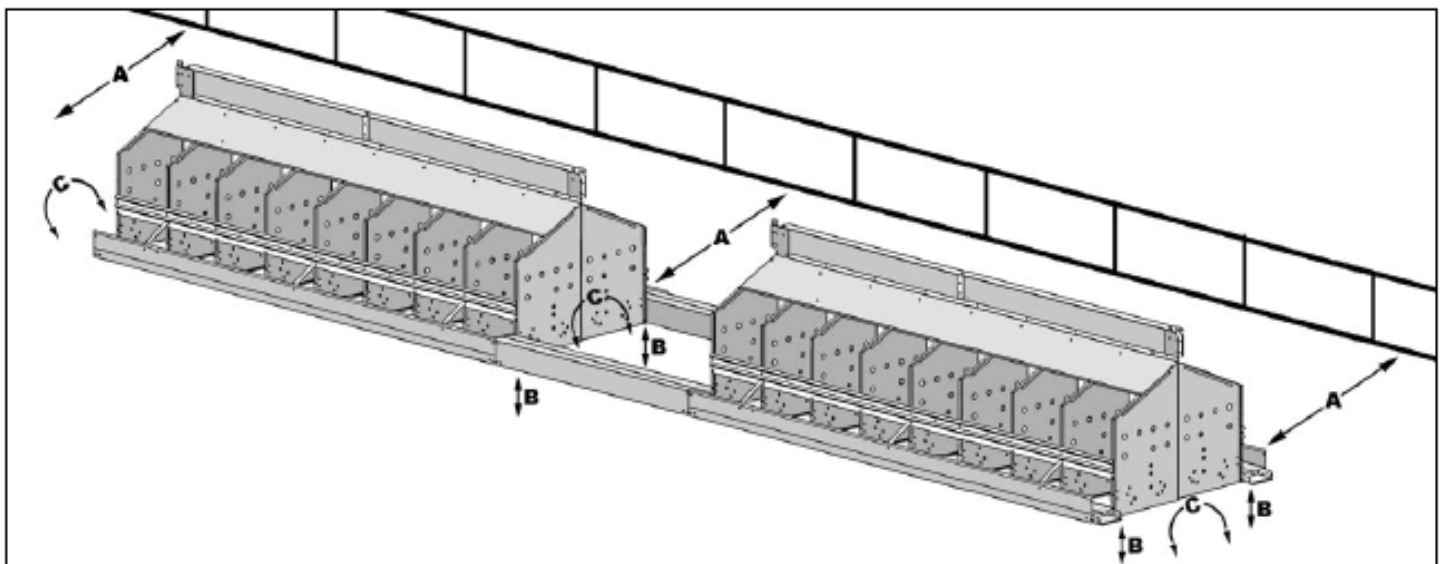

## END RETURN ROLLER ASSEMBLY 16560065

Before beginning to run egg belt into the nest line, install two Belt Entry Guides, P/N 16560323, at the back end of the line on each of the belt support trays with pop-rivets as shown. This will protect the plastic egg belt from the sharp edge of the sheet metal parts alongside the entry point of the belt onto the conveyor support tray.

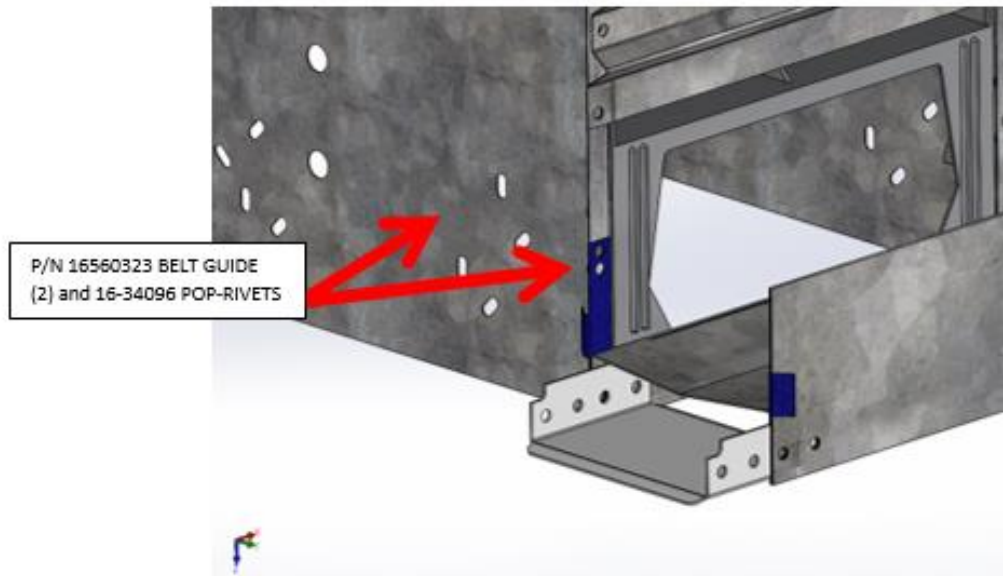

For retrofit of existing systems, the Rear Return Roller assembly at the back of the nest line will need to be removed to provide access to install this part.

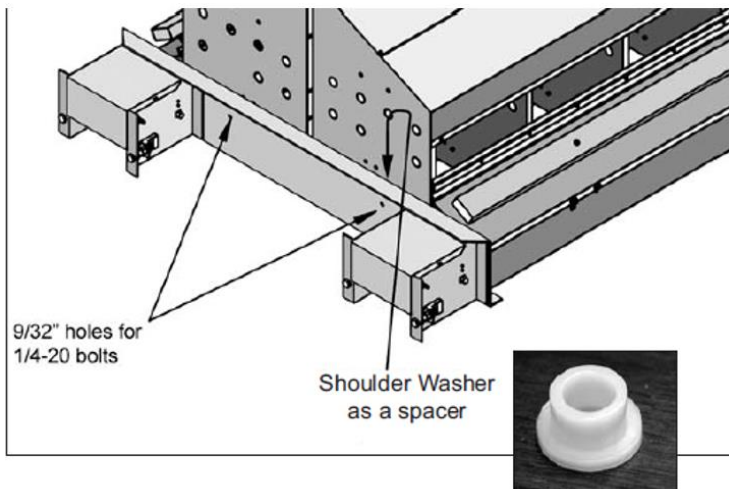

1. Align Roller Assembly to Last Nest End as shown, making sure that rollers are lined up with the centers of the Egg Trays.
2. Use Idler Assembly as a guide to drill two  $9/32$ " holes for  $1/4$ -20 bolts.
3. Two  $1/4$ -20x1" bolts and two  $1/4$ -20 flange nuts and one nylon shoulder washer are included for Return Roller Assembly attachment. Use the shoulder washer as a spacer – see picture above. Refer to page 16 for components.

**STEP 1 - PULLEY & SPACER ATTACHMENT**

Assemble Spacers & Pulleys on Bolt through 3/8" diameter hole in nest back beside the center flipper support. Orient Pulleys as shown and tighten 3/8" Nylock Nut securely.

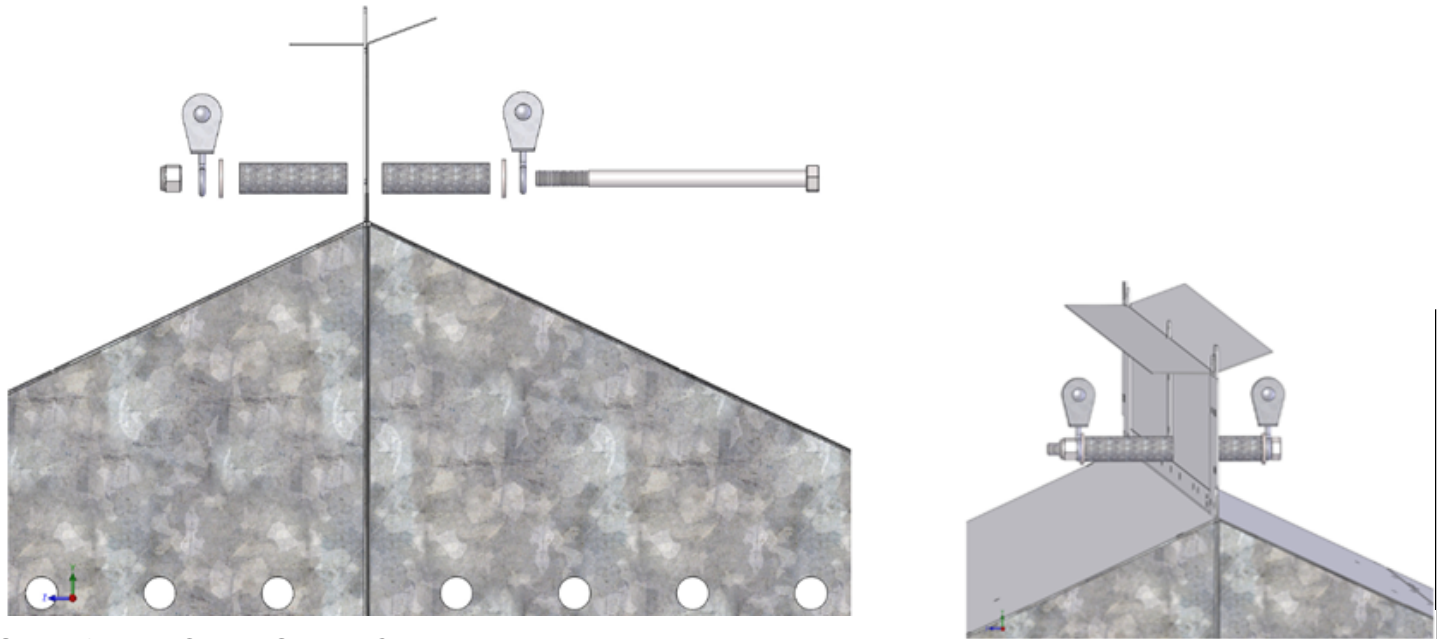

**STEP 2 - LID SPRING ATTACHMENT**

Attach three Lid Springs to each Hinged Lid and Nest Top with Pop-Rivets. For best results, orient Pop-Rivets through the Springs and outward through the Tops and/or Lids as shown. Each Lid requires three Springs.

NOTE : The Springs will require slight compression to align the rivet holes with the holes in the Tops & Lids.

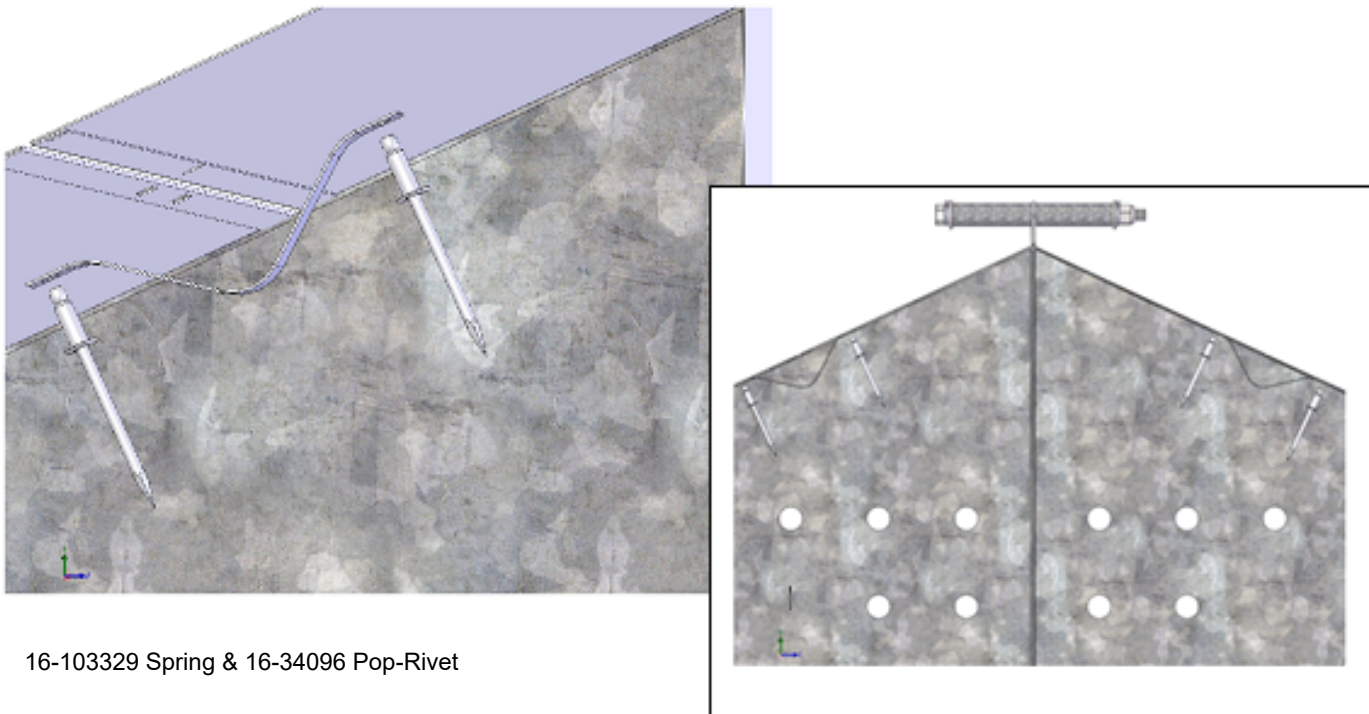

16-103329 Spring & 16-34096 Pop-Rivet

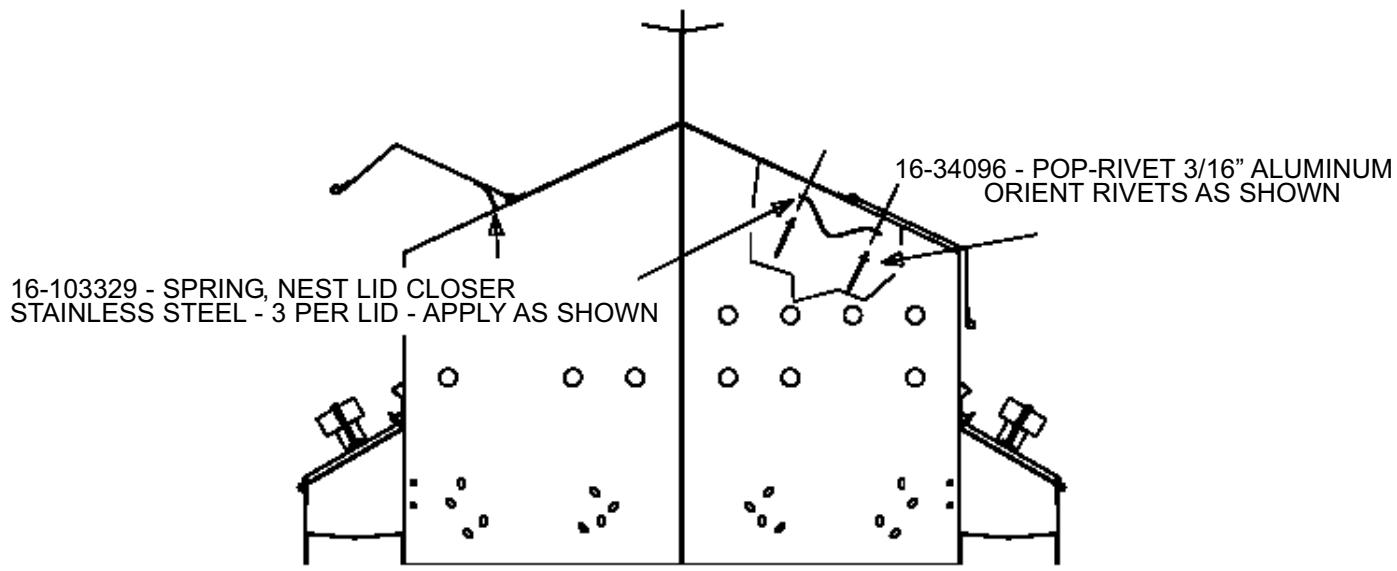

## NEST LID SPRING ATTACHEMENT & POSITION

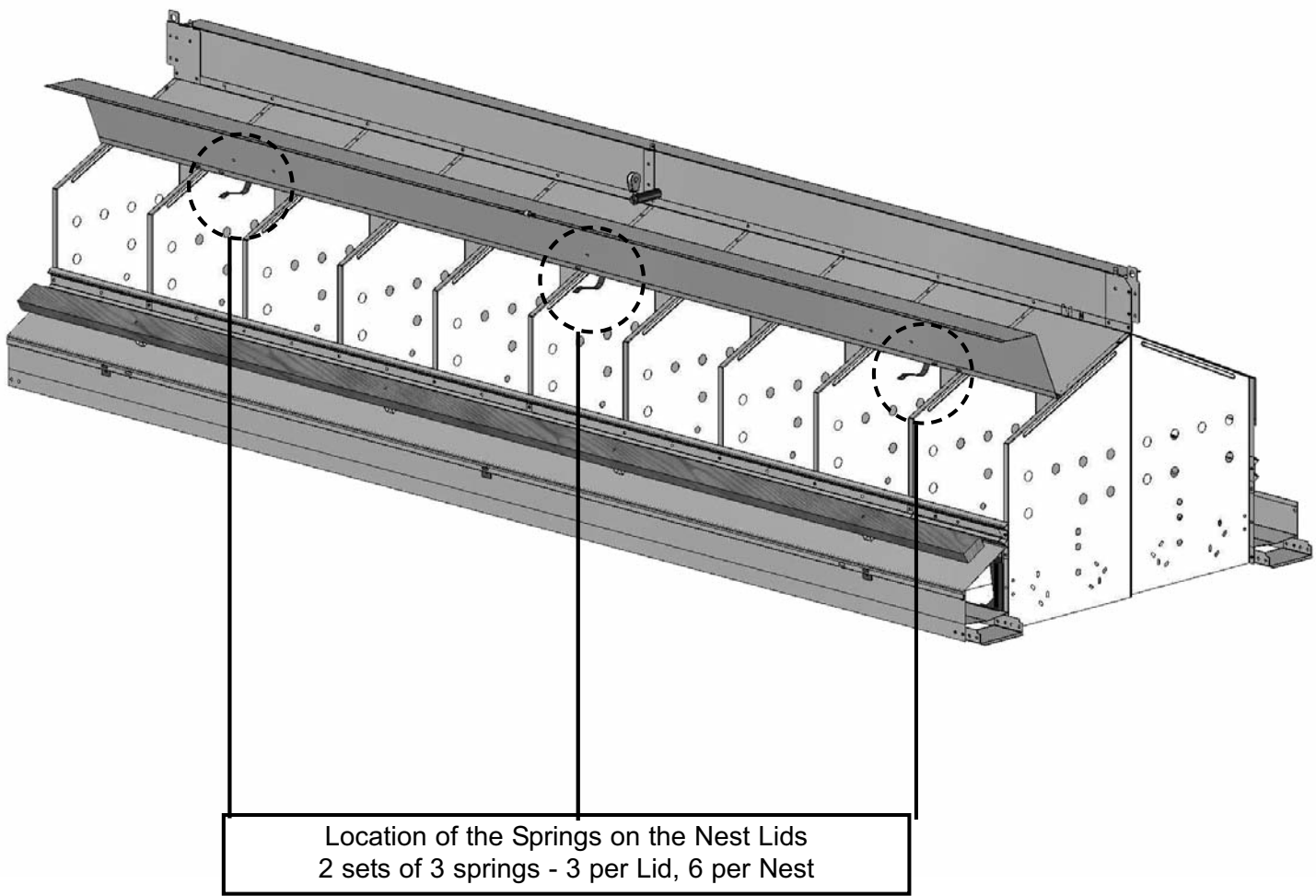

**STEP 3 - CORD CLIPS ON LIDS**

Attach one plastic Cord Clip to each Lid with a Pop-rivet oriented as shown. For best results, attach the clip to the lid at the hole that best aligns with the Pulley above it. See diagrams on the following pages.

Front side of Nest with Cord Clip and Pulleys attached.

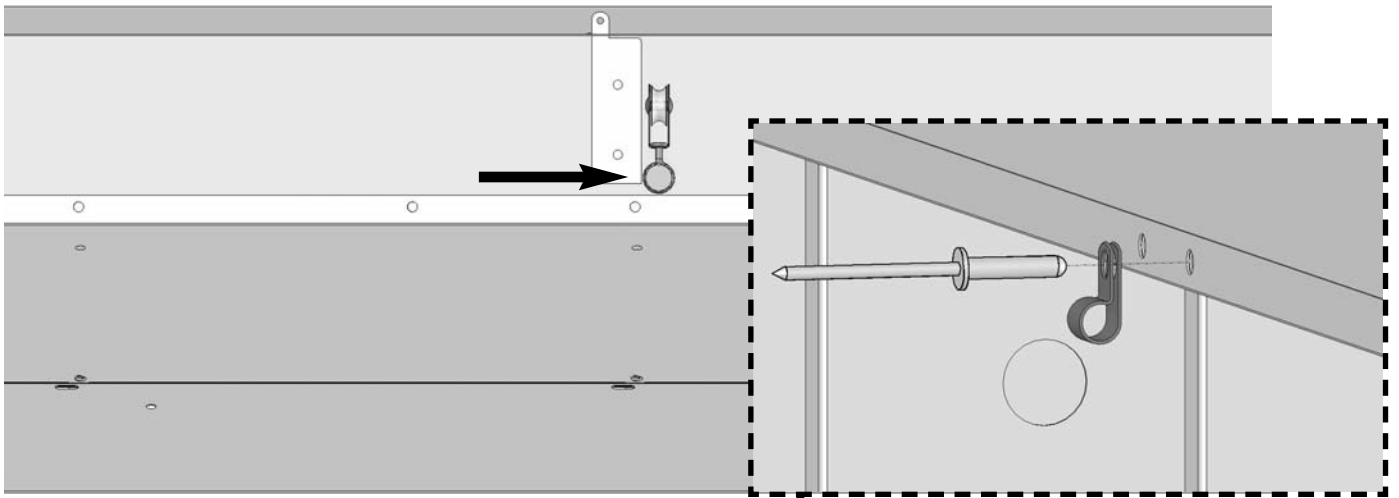

Attach clip in RIGHT hole on nest lid  
(Also shown below.)

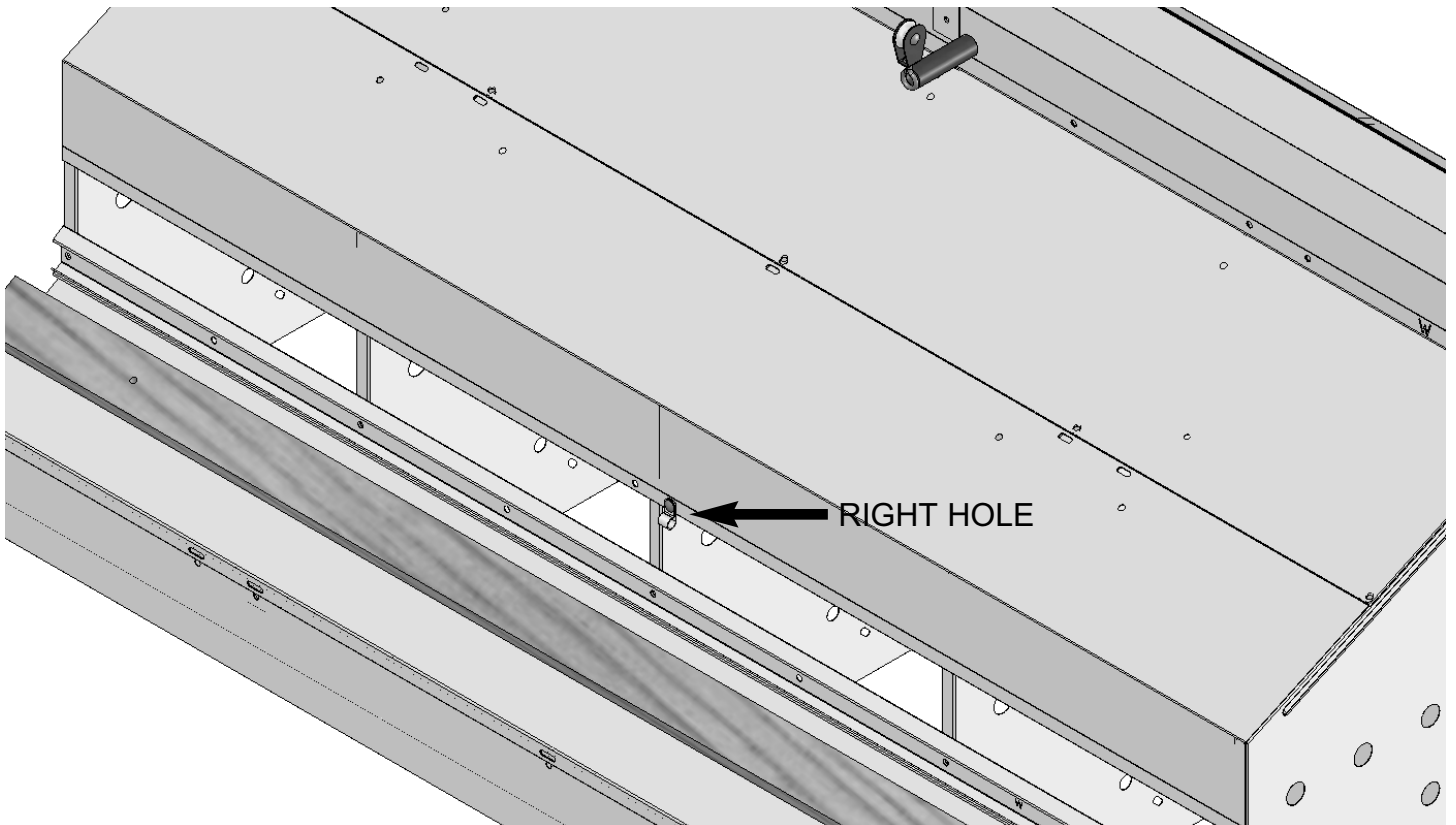
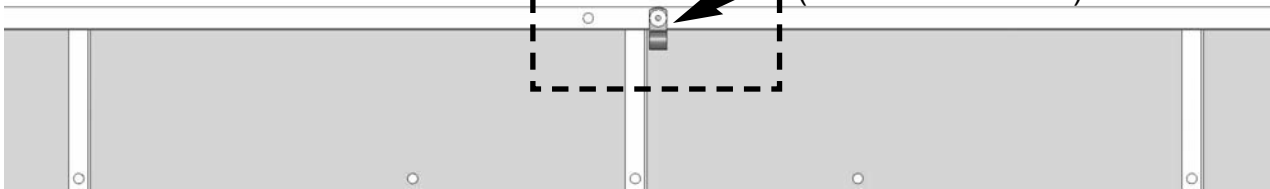

Opposite side of same Nest with Cord Clip and Pulleys attached.

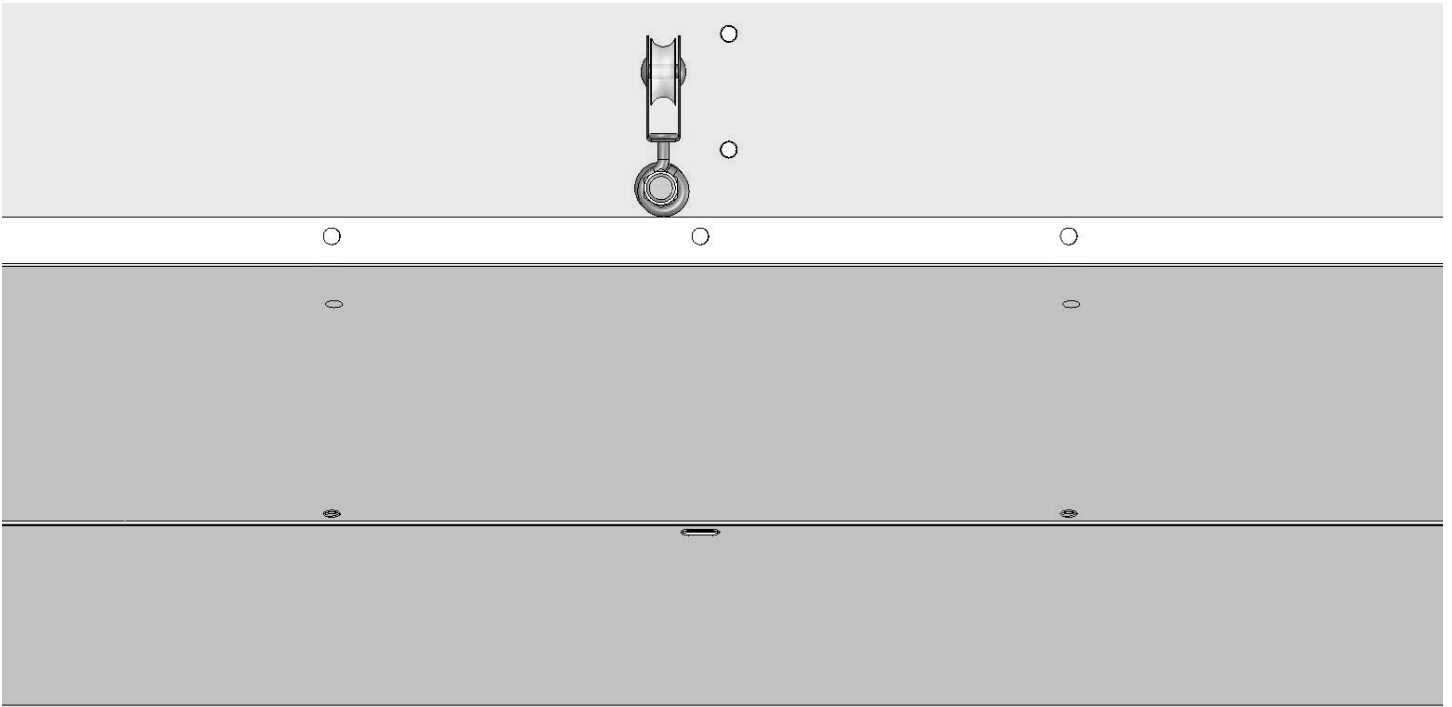

Attach clip in LEFT hole on nest lid. (Also show below)

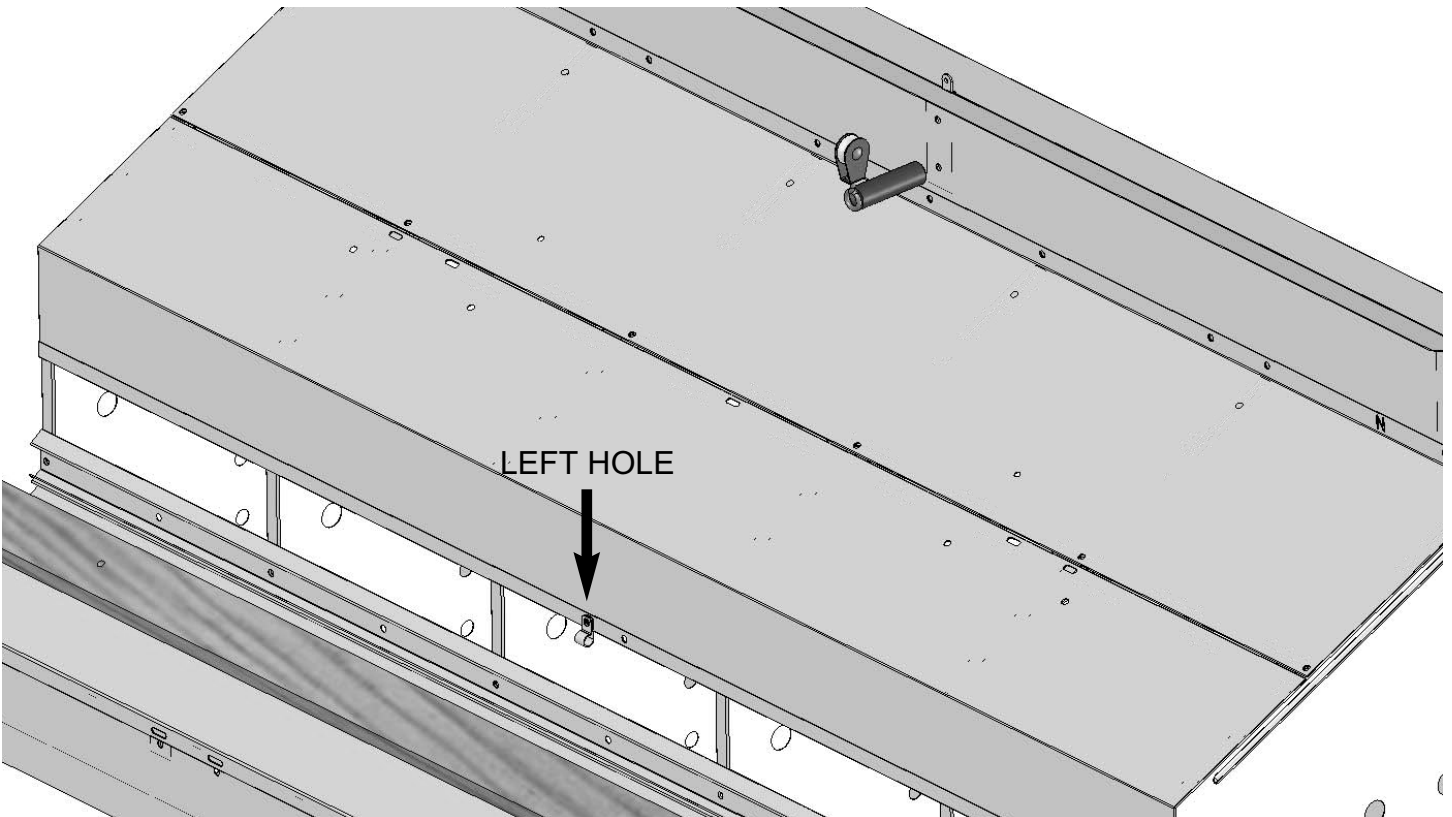
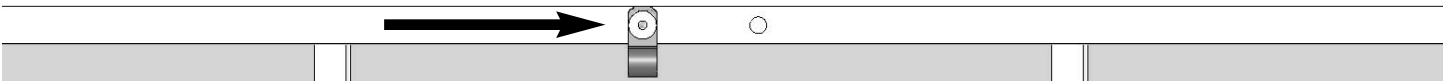

**STEP 4 - NEST LID CORD ATTACH AND CABLE SYSTEM DETAIL**

Use 1/8" Nylon cord (not supplied) to connect the Lids to the main cable to avoid fatigue & breakage from repeated open & close operation. The diagram shown below gives a perspective view of the cord and cable connections to the nest Lids and drive system. The main system cable should be offset from overhead-center of the nest line to avoid interference with the nest line suspension system. The pulleys, cable, mounting hooks, crimp-on clamps, and return springs shown are common suspension items and are NOT included in the Auto-Closer Kit. See the list of available parts from Manufacturer at the beginning of this document.

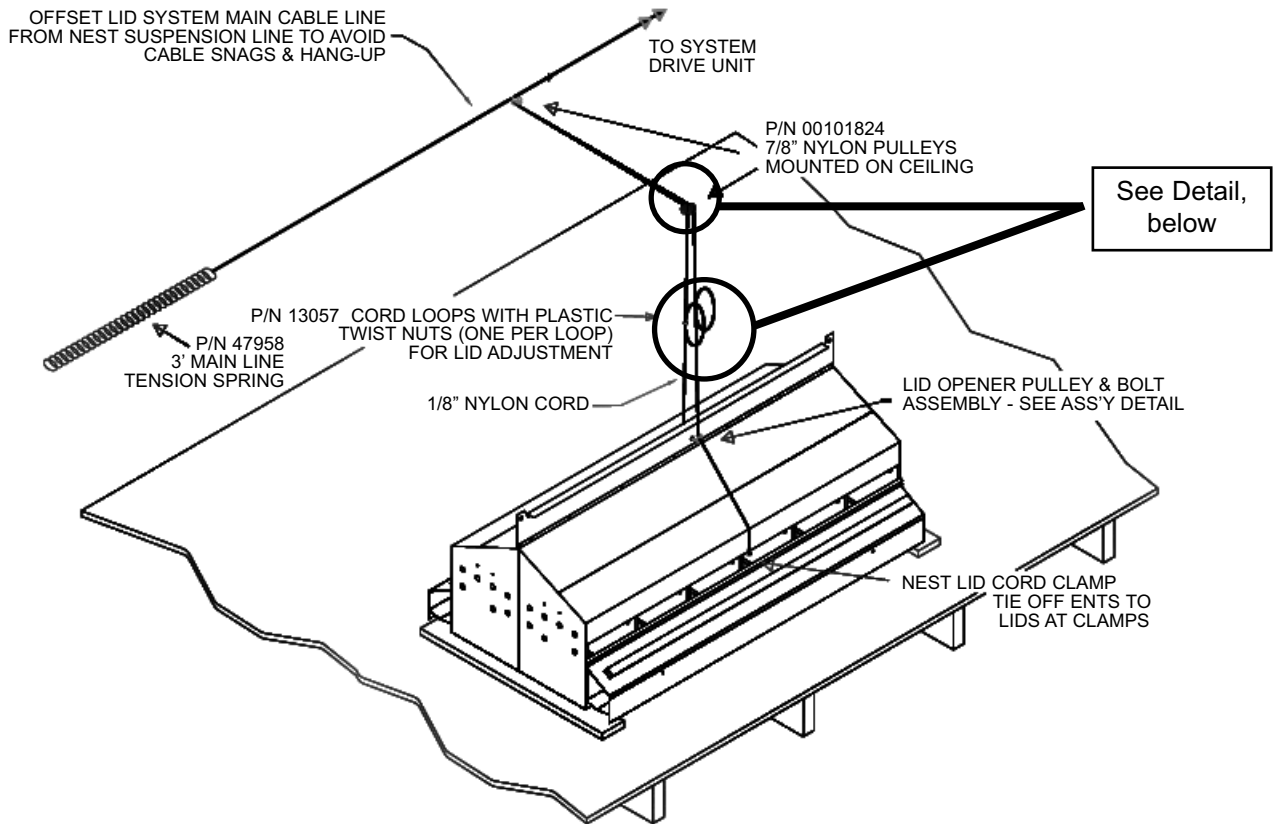

**NEST LID CORD ATTACHMENT & ROUTING**

View of double cord pulleys installed on ceiling.

Allow enough cord length to each lid to allow a loop for system individual lid adjustment at startup after each flock clean-out. Place a cord clamp on each loop as shown.

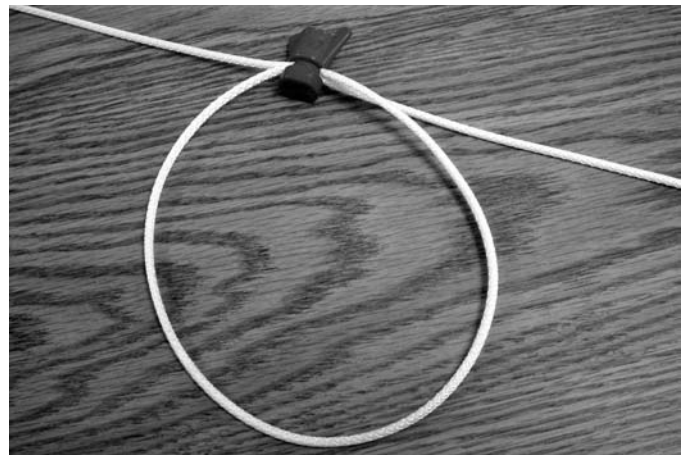



An extension spring is required at each main cable line end to provide back-tension on the main cable and avoid slack and maintain lid adjustment.

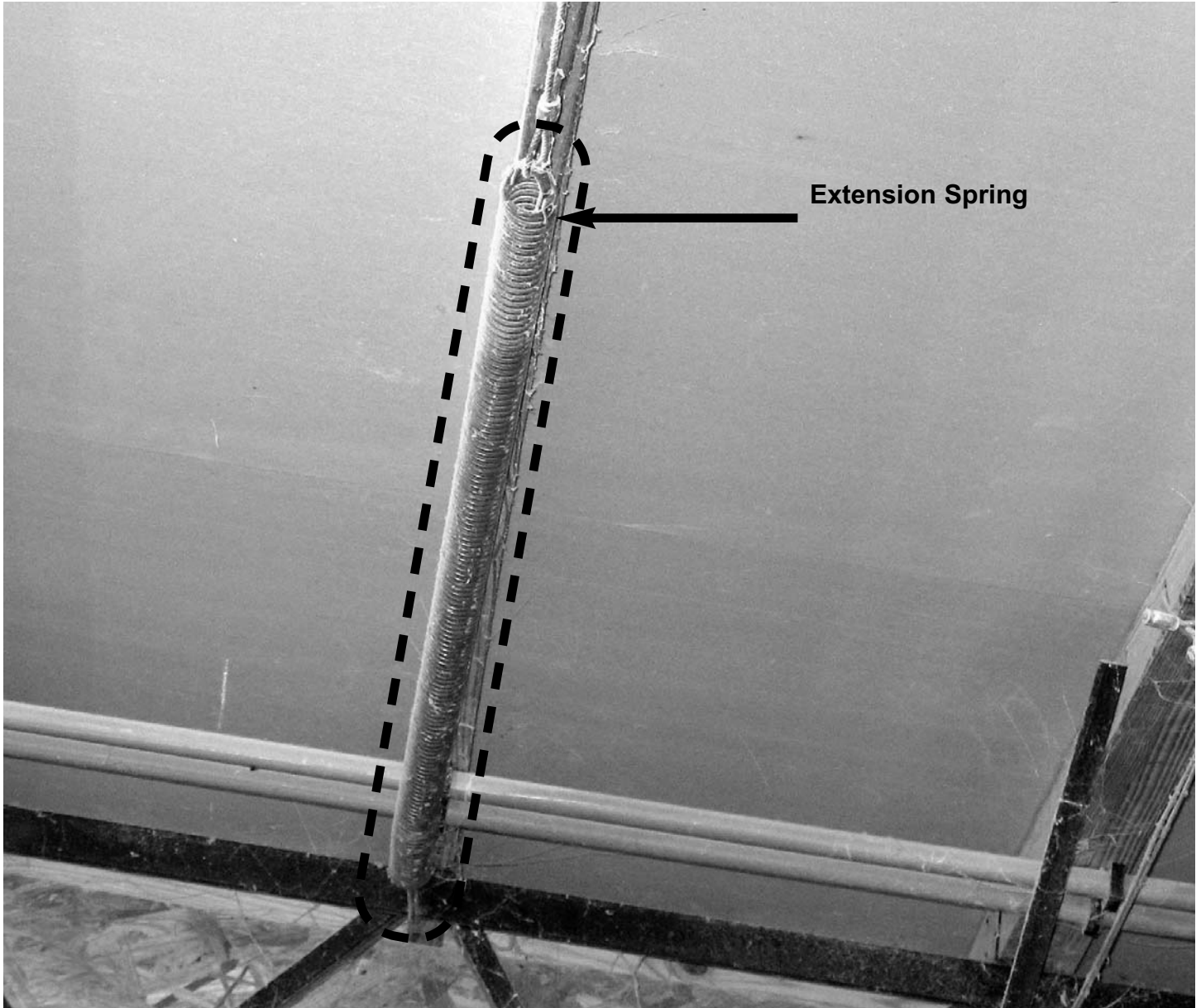

**STEP 5 - SYSTEM LOAD AND POWER UNIT CONNECTION DETAIL**

On nests with two sets of double springs installed on each lid, each nest will require a combined pull force of 25 lbs. (min. approx.) and a travel of 16" to fully open the lids. For reliable, long term operation of an automated lid system, Manufacturer specifies the following application limits for system layouts:

- For nest systems (houses) with **Up To And Including 60 Nests**, a chain drive linear-type power unit with a travel stroke of 22" or more can be used in a direct connection configuration (see below).
- For nest systems (houses) with **61 Nests And Over**, a chain drive linear-type power unit with a travel stroke of 44" or more must be used in a turn-back connection configuration (see below).

**REQUIRED PULL FORCE : 25 LBS PER NEST (LID PAIRS)**

**REQUIRED SYSTEM TRAVEL : 16" (CLOSED TO FULL OPEN)**

**DRIVE SYSTEM REQUIREMENTS:**

CONNECT NO MORE THAN 62 NESTS (1550 LBS.)  
IN EITHER 1 OR 2 LINES OF NESTS TO SYSTEM  
DRIVE UNIT IN DIRECT-PULL CONNECTION.

SYSTEMS CONNECTING OVER 62 NESTS REQUIRE A  
TURN-BACK LINE CONNECTION AND A DRIVE UNIT  
WITH A MINIMUM STROKE LENGTH OF 36". A UNIT  
WITH 48" STROKE LENGTH IS PREFERRED FOR LINE  
ADJUSTMENT ALLOWANCE.

**DIRECT CONNECTION**

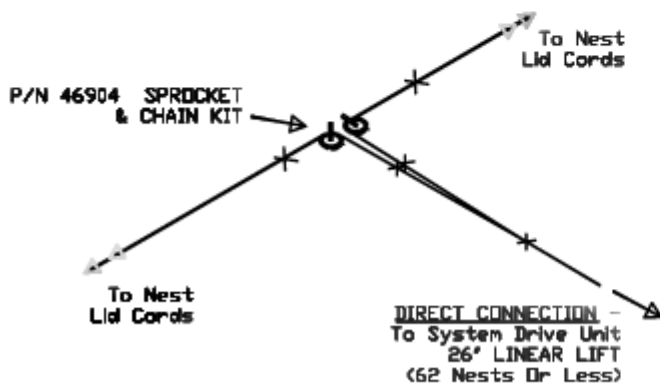

**TURN-BACK CONNECTION**

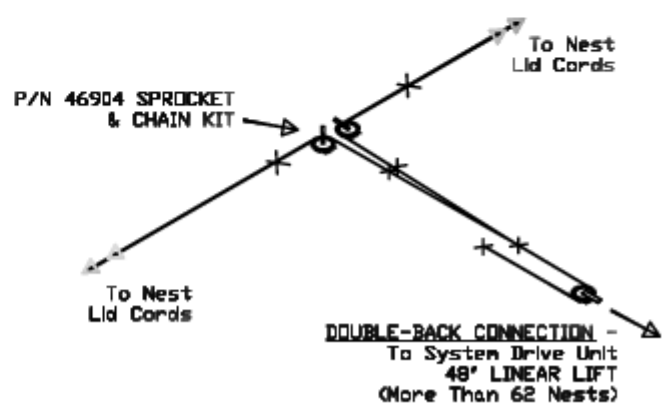

# CONNECTION TO CHAIN DRIVE UNIT

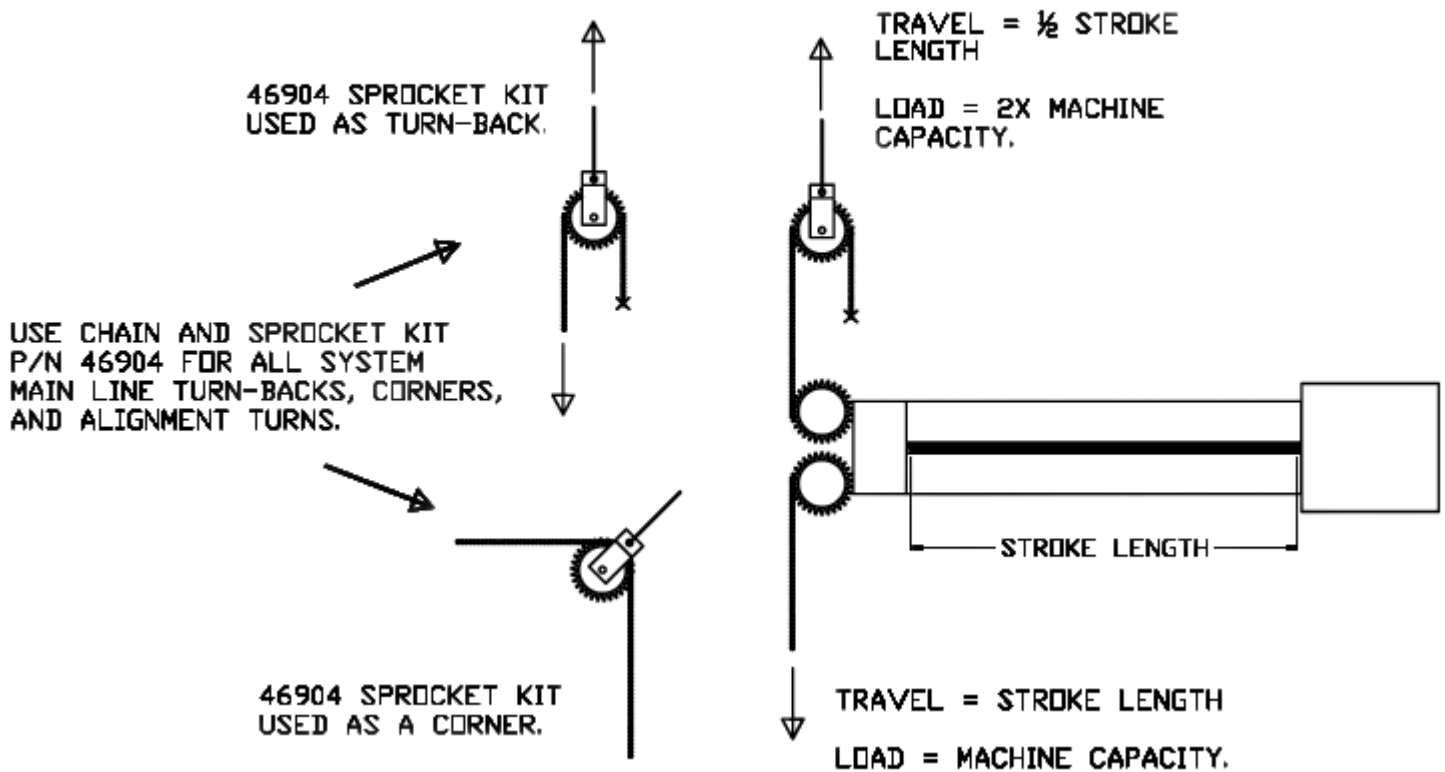

A chain and sprocket kit, such as P/N 46904 (see below), is required on all system drive line corners and turn-backs to prevent fatigue and breakage from repeated operation. Refer to the diagram below to plan the system installation.

Pro-Terra Linear Lift w/chain

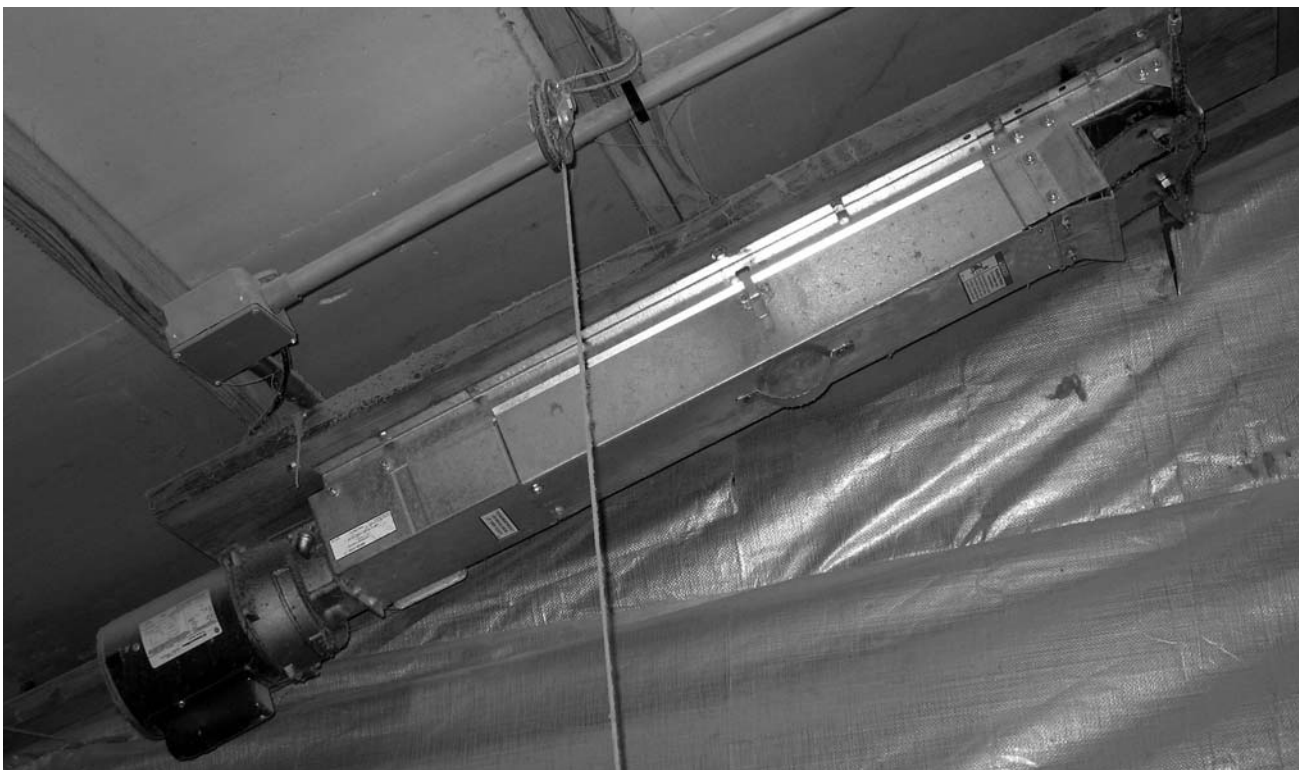

## Plastic Egg Belt Splice w/Lacing

The following steps describe how to apply a splice in plastic egg conveyor belt using interwoven strapping/lacing as the method of connection. The finished splice should look like the picture below when completed. Follow the steps outlined to prepare the belt and splice.

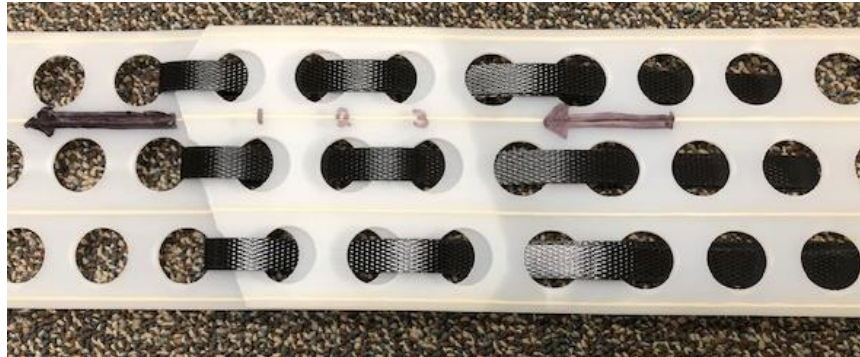

- 1) With the belt routed out and back through the nest line support trays and through the collection table, the belt splice's trailing edge (underside) should be trimmed like this:



Also, this end of the belt can be clamped to the table near the drive roller to avoid slipping while the leading edge (top side of splice) is pulled to apply tension on the belt. Set the clamp about 5" to 6" away from the free end of the belt.

- 2) Pull the top side of the belt far enough to draw the belt slack adjustment slider block in the table all the way to the front of its travel within the guides. The belt ends will need to overlap by three holes after cutting:



- 3) With tension applied to the belt, trim the leading edge of the belt as shown:



The belt overlap with top and bottom ends trimmed and belt line tension applied.



- 4) Cut six pieces of Strapping material 18" long and fold each in half to form a double-thick length 9" long. Along one of the lines of holes in the belt, thread one end of the doubled strap length down through the hole ahead of the top leading edge. Thread the other end of the doubled strap through the 1<sup>st</sup> aligned holes behind the top leading edge:



- 5) Thread both ends of the doubled strap together up through the 2<sup>nd</sup> set of aligned holes behind the top leading edge:

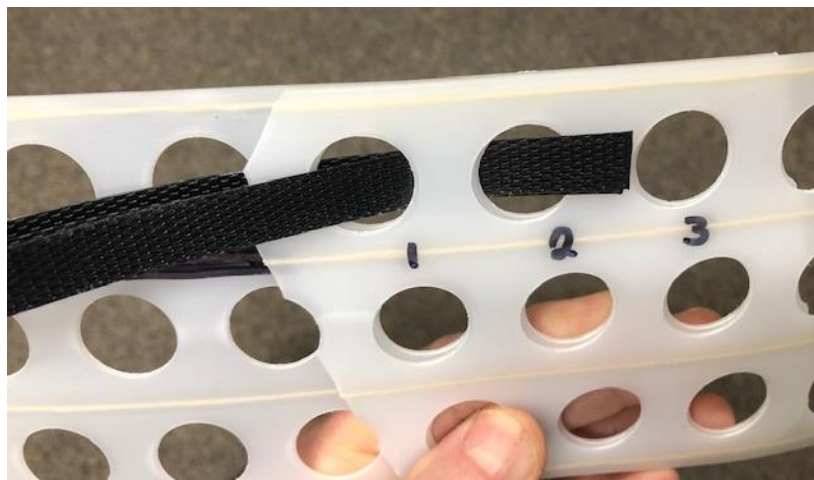

- 6) Now thread both ends of the doubled strap together down and up again through the 3<sup>rd</sup> and 4<sup>th</sup> sets of aligned holes behind the top leading edge:

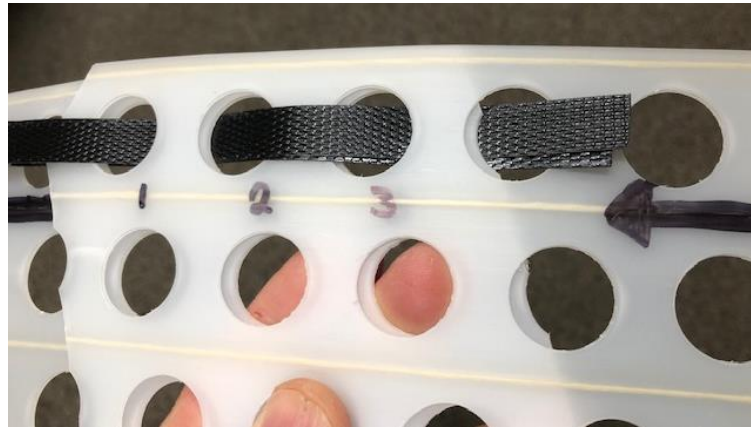

- 7) Tuck the doubled strap down through the 5<sup>th</sup> hole behind the top leading edge and pull the strapping tight away from top leading edge. Note that the strapping captures both the Top Leading edge and the Trailing Bottom edges.

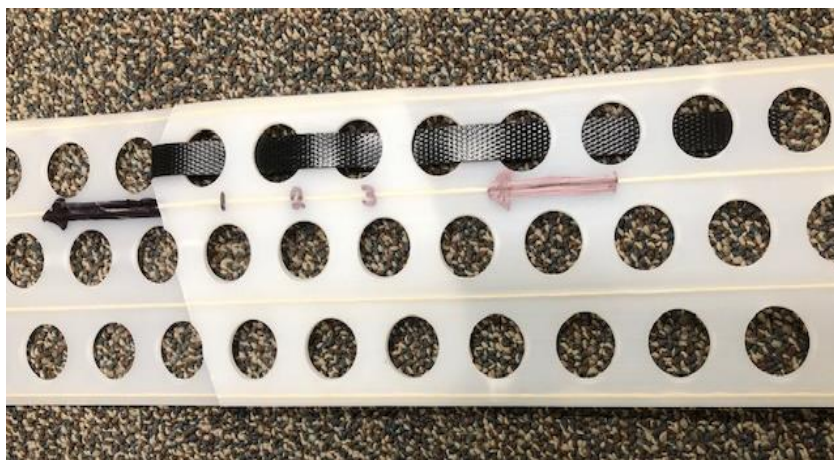

- 8) Repeat the process for the remaining two lines of holes.

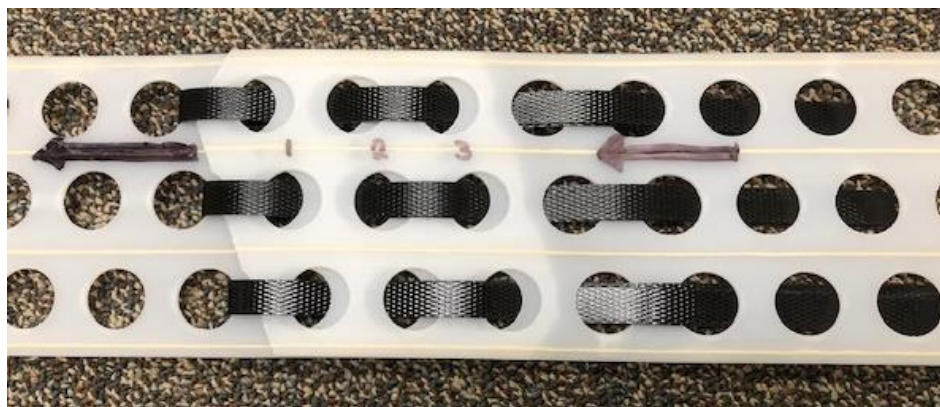

- 9) Release any clamps securing the belt and adjust the springs on both sides of the pinch roller to apply pressure to the belt and drive roller. The springs should be compressed to 2-1/2" to 2-1/4" long for best grip on the belt.